

# ZO Scroll Compressors For Subcritical R-744 (CO<sub>2</sub>)

Launch Package 2010



**Copeland**<sup>®</sup>  
brand products



**EMERSON**<sup>™</sup>  
Climate Technologies

# R-744 vs HCFC/HFC

	R-744	HCFC/HFC	Impact On R-744 Systems
Global Warming Potential	1	1300-3800	Green Refrigeration
O-zone Depleting Potential	0	0 For HFC + For HCFC	Green Refrigeration
Saturation Pressures	Higher	Lower	Additional Safety Design
Standstill Pressure	Higher	Lower	Venting, Relief Tanks, Etc.
Operating Pressure	Higher	Lower	Leak Impact On Performance (Hermetic)
"Rupture" Energy	Higher	Lower	Additional Safety Design
Inert Gas	Yes	Yes	Materials Like Copper May Be Used
Flammability	A1	A1	Not Flammable
Toxicity Odor	No None	No None	>1000 ppm Harmful Leak Detectors, Ventilation
Volumetric Mass Flow	Higher	Lower	Smaller Tubes & Compressors
Heat Transfer	Higher	Lower	Better Thermal Efficiency
High Ambient Performance	Lower	Higher	System Design To Compensate
Low Ambient Performance	Good	Good	Annual Basis Comparison (AEER) & Sub-Critical Cascade Systems Favorable
Cost Per Pound	Low	Higher	Economical
Complexity Of System	Higher	Lower	Higher First Cost Training & Experience
Adoption	Low	Higher	Higher First Cost
Legislation Potential	Low	Higher	Long-Term Viability

**R-744 Provides Many Benefits Over HFC Options**

# HFC Direct Expansion System With CO<sub>2</sub> Secondary Loop

## ■ CO<sub>2</sub> Has Excellent Thermal Properties

- High Heat Transfer
- High Volumetric Flow
- Low Pump Power
- Small Pipe Size

## ■ Can Be Used As A Secondary Coolant In Refrigeration

- No Phase Change
- No Compressors In CO<sub>2</sub> Circuit
- Pumps Circulate CO<sub>2</sub> Liquid Through Heat Exchangers To Cool

CO<sub>2</sub> Use As A Secondary Fluid Reduces  
Total HFC In Store

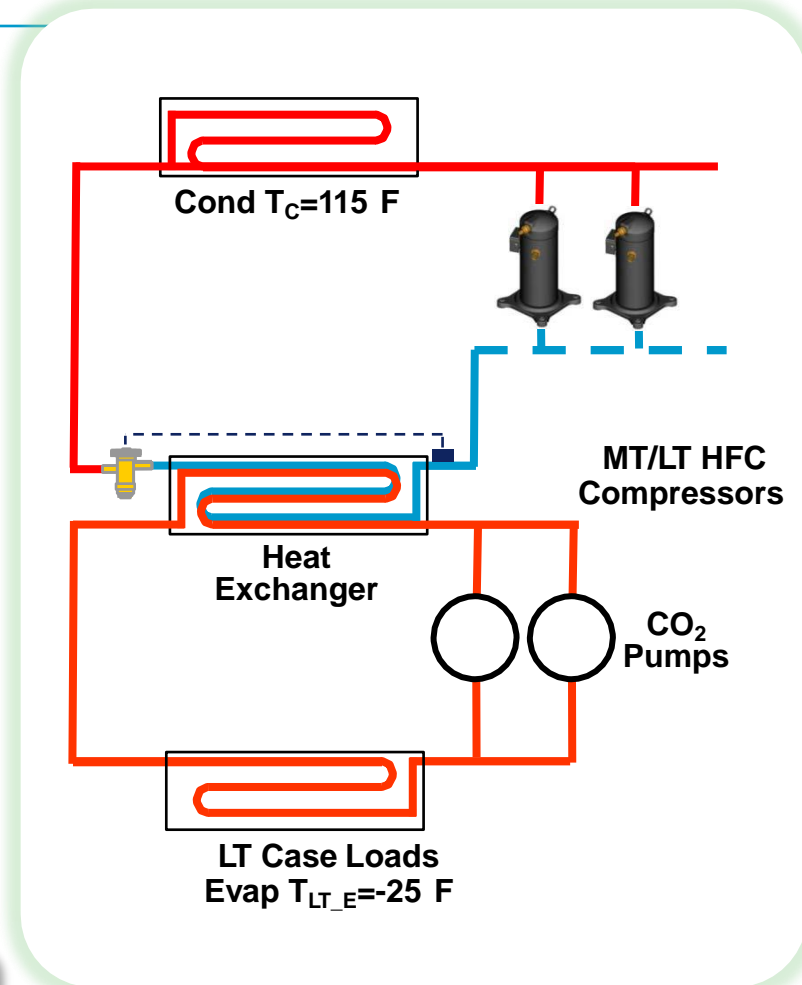

# CO<sub>2</sub> For Low Temperature Applications Sub-Critical DX System

**Cascade System**  
(High Stage: HFC  
Low Stage: Subcritical CO<sub>2</sub>)

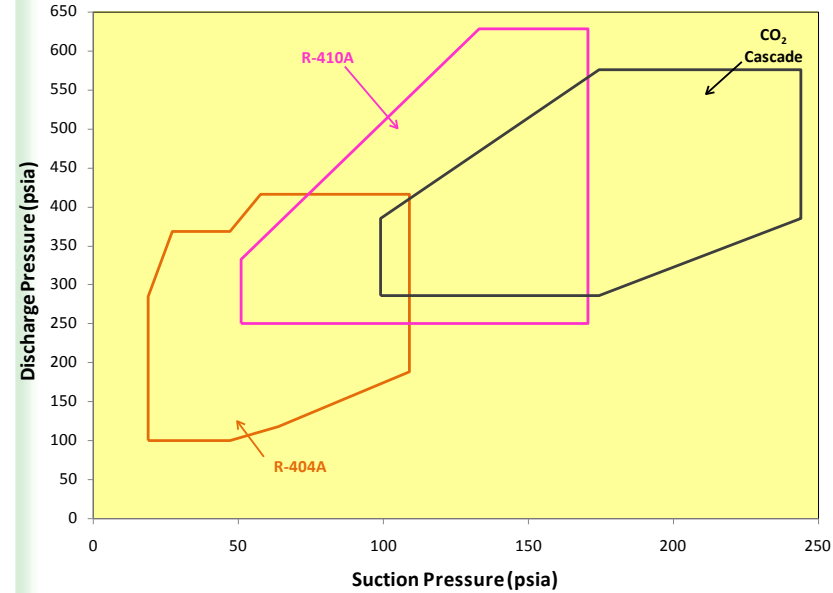
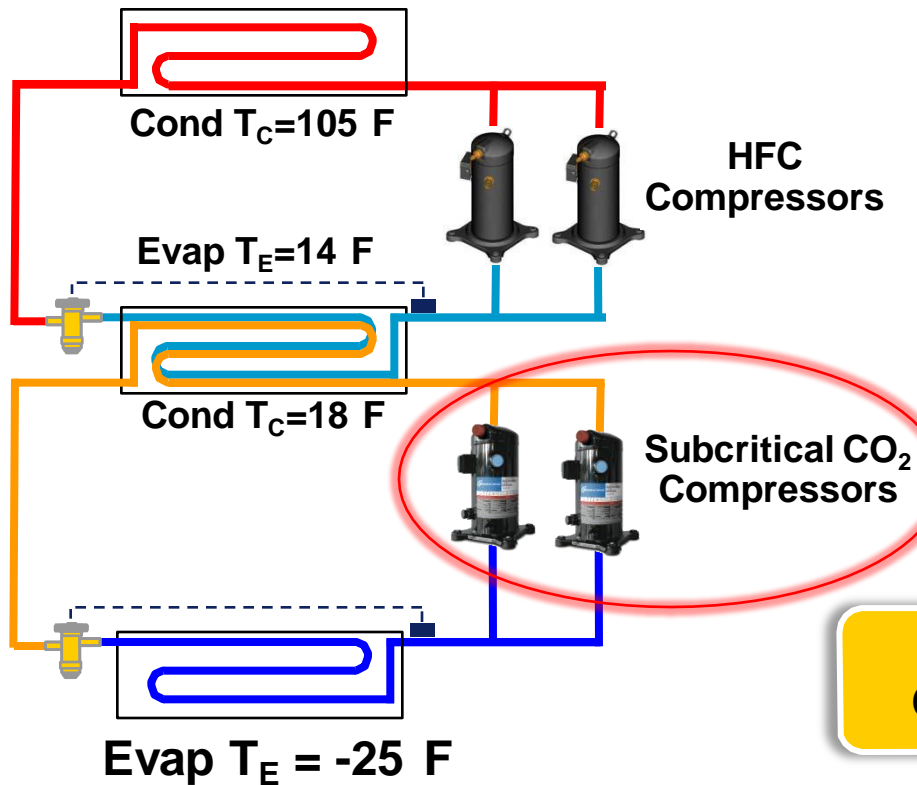

**CO<sub>2</sub> Used As A Refrigerant  
Can Further Reduces Total HFC In Store**

# Subcritical CO<sub>2</sub> Product Offering ZO Scroll Compressor

- Based On Proven Copeland Scroll Technology
- Designed For CO<sub>2</sub> Pressure And Lubrication Requirements
- Proven Reliability With Other High Pressure Refrigerants



*Capacity Data Preliminary*

Model	Nominal Horsepower	Displacement	Capacity	EER
ZO21K5E	1.0	112 CFH	20,800 btuh	15.4
ZO34K3E	2.0	172 CFH	32,000 btuh	15.4
ZO45K3E	2.5	228 CFH	44,500 btuh	16.5
ZO58K3E	3.5	291 CFH	57,000 btuh	16.7
ZO88K3E	5.0	431 CFH	85,300 btuh	16.3
ZO104KCE	6.0	498 CFH	98,500 btuh	16.3

← **\*\*Digital Available\*\***

← **\*\*Digital Available\*\***

230, 460, 380, and 575V models available

Capacity with R-744 at -31F evap, 14F cascade cond, 5F RG, 14F liquid

**Hermetic Design – Least Potential For Leaks With High Pressure CO<sub>2</sub>**

# Copeland Scroll ZO for Subcritical CO<sub>2</sub>

10-100% Digital Modulation Available

Max. Highside Pressure:  
43 Bar / 630 psi

Scroll Compression:  
High Isentropic Efficiency & Low Sound/Vibration

High Efficiency Motor

Small Footprint & Lightweight

Max. Standstill Pressure:  
28 Bar / 410 psi

UL Approved:  
3x Burst Pressure  
+ Fatigue Cycling



Production Release Status

Model	Production Release Status			
	TFD 460 V	TF5 230 V	TFE 575 V	TF7 380 V
ZO21				
ZO34			March 2014	
ZOD34			March 2014	
ZO45				
ZO58				
ZO88				
ZO104				
ZOD104				

**Large Majority of ZO Products Now Available**

# ZO Product Operating Map

## Low Temperature ZO Scroll Envelope (Subcritical CO<sub>2</sub>)

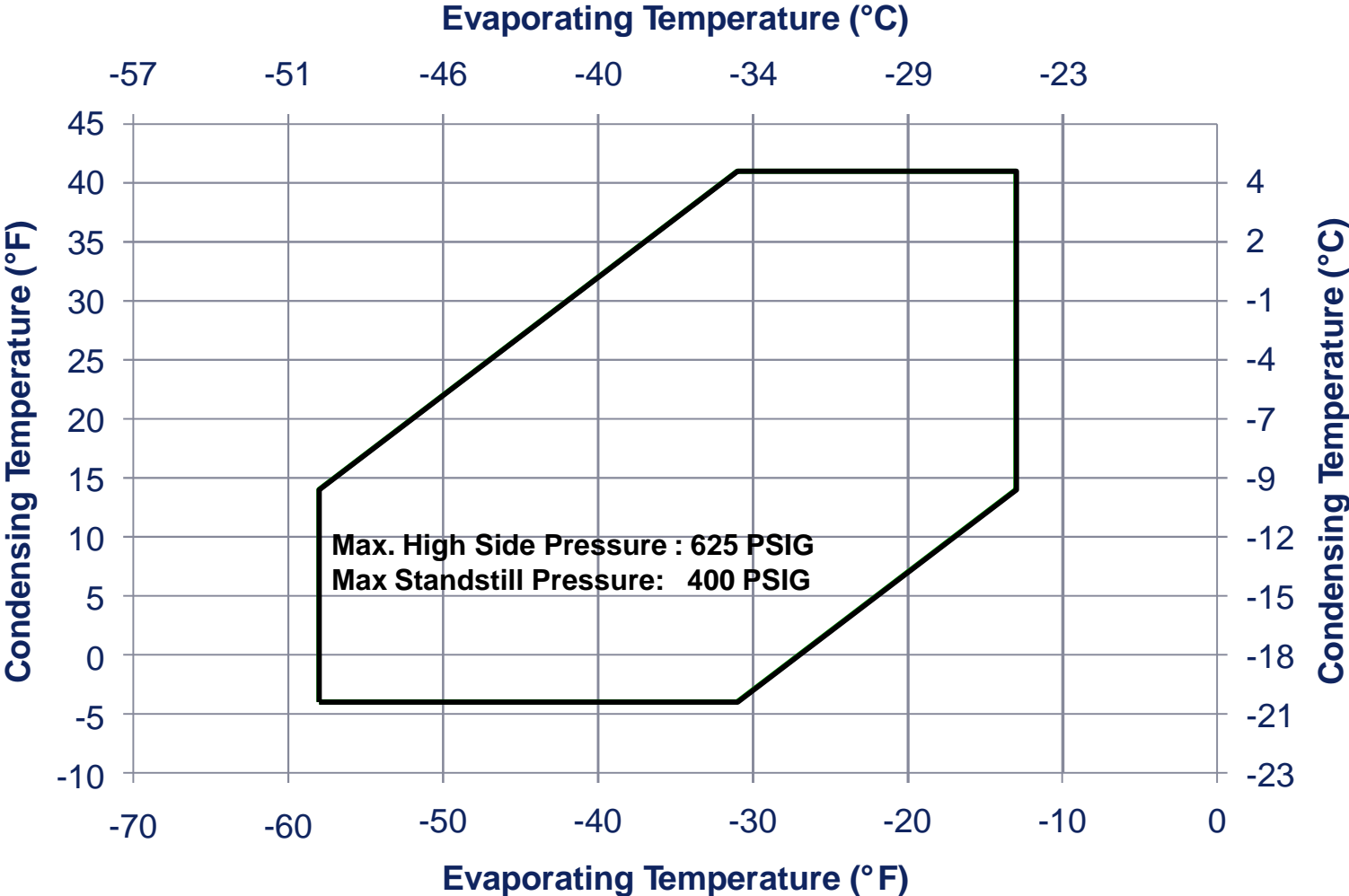

# ***ZO Sub-critical CO<sub>2</sub> Compressor Release In The U.S. – UL Approved***

- **CO<sub>2</sub> Approved ASME Safety Pressure Relief Valve(s) On Scroll Compressor For Standstill Conditions (Shipped With)**
  - **ASME Relief Valve Setting: 500 psig**
  
- **All Sections That Can Be Isolated In System To Have Relief Valves For Standstill Conditions (Installed By System Manufacturer)**
  - **System Manufacturer Installed Relief Valve Setting: <450 psig**
    - **Select The System Pressure Relief Valves To Protect Other System Components**
  
- **Additional Requirements By Emerson**
  - **Low Pressure Cut-Out On Suction Side: 87 psig**
  - **High Pressure Cut-Out On Discharge Side: 623 psig**
  - **Discharge Temperature Protection**

# Resources & Supplemental Materials

MARKET SOLUTIONS

## Product Website

ABOUT US

---

Version: Draft (0.11) Status: Checked in and viewable by authorized users. Publication Start Date: Immediately

Page | Workflow | Tools | Edit Page | Submit for Approval

---

Home > Products > Compressors > Scroll Compressors > Refrigeration > CO2 Compressors

**COMMERCIAL**

**REFRIGERATION**

Copeland Digital Scroll For Refrigeration

**CO2 Compressors**

**RESIDENTIAL**

### CO2 Compressors

Emerson Climate Technologies offers the Copeland Scroll® ZO compressor which has been designed to take advantage of the characteristics of a R744 (CO<sub>2</sub>) refrigeration system.

**No Potential Environment Hazard**

- Capitalizes on the unique non-ozone depleting, non-flammable, low global warming potential properties of CO<sub>2</sub> refrigerants;
- Takes advantage of CO<sub>2</sub>'s excellent thermal properties and utilizes it as a secondary coolant to reduce hydrofluorocarbon (HFC) usage.

**Compact, Lightweight Design**

- 30% to 60% lighter than other reciprocating piston compressors of similar capacity;
- Eliminates refrigerant leakage;
- Enables easier transport, installation and maintenance.

**Designed for CO<sub>2</sub> Pressure and Lubrication Requirements**

- Encased in strong steel shell tested to withstand high pressure levels;
- Copes with higher mass flow by not utilizing suction and discharge valves;

EMAIL THIS PAGE

Why Register Here? Click to Register Forgot Password

## Online Product Information

ABOUT US

---

Version: Draft (0.11) Status: Checked in and viewable by authorized users. Publication Start Date: Immediately

Page | Workflow | Tools | Edit Page | Submit for Approval

---

Home > Products > Compressors > Scroll Compressors > Refrigeration > CO2 Compressors

**COMMERCIAL**

**REFRIGERATION**

Copeland Digital Scroll For Refrigeration

**CO2 Compressors**

**RESIDENTIAL**

### CO2 Compressors

Emerson Climate Technologies offers the Copeland Scroll® ZO compressor which has been designed to take advantage of the characteristics of a R744 (CO<sub>2</sub>) refrigeration system.

**No Potential Environment Hazard**

- Capitalizes on the unique non-ozone depleting, non-flammable, low global warming potential properties of CO<sub>2</sub> refrigerants;
- Takes advantage of CO<sub>2</sub>'s excellent thermal properties and utilizes it as a secondary coolant to reduce hydrofluorocarbon (HFC) usage.

**Compact, Lightweight Design**

- 30% to 60% lighter than other reciprocating piston compressors of similar capacity;
- Eliminates refrigerant leakage;
- Enables easier transport, installation and maintenance.

**Designed for CO<sub>2</sub> Pressure and Lubrication Requirements**

- Encased in strong steel shell tested to withstand high pressure levels;
- Copes with higher mass flow by not utilizing suction and discharge valves;

EMAIL THIS PAGE

Why Register Here? Click to Register Forgot Password

## Press Release

ABOUT US

---

Version: Draft (0.11) Status: Checked in and viewable by authorized users. Publication Start Date: Immediately

Page | Workflow | Tools | Edit Page | Submit for Approval

---

Home > Products > Compressors > Scroll Compressors > Refrigeration > CO2 Compressors

**COMMERCIAL**

**REFRIGERATION**

Copeland Digital Scroll For Refrigeration

**CO2 Compressors**

**RESIDENTIAL**

### CO2 Compressors

Emerson Climate Technologies offers the Copeland Scroll® ZO compressor which has been designed to take advantage of the characteristics of a R744 (CO<sub>2</sub>) refrigeration system.

**No Potential Environment Hazard**

- Capitalizes on the unique non-ozone depleting, non-flammable, low global warming potential properties of CO<sub>2</sub> refrigerants;
- Takes advantage of CO<sub>2</sub>'s excellent thermal properties and utilizes it as a secondary coolant to reduce hydrofluorocarbon (HFC) usage.

**Compact, Lightweight Design**

- 30% to 60% lighter than other reciprocating piston compressors of similar capacity;
- Eliminates refrigerant leakage;
- Enables easier transport, installation and maintenance.

**Designed for CO<sub>2</sub> Pressure and Lubrication Requirements**

- Encased in strong steel shell tested to withstand high pressure levels;
- Copes with higher mass flow by not utilizing suction and discharge valves;

EMAIL THIS PAGE

Why Register Here? Click to Register Forgot Password

## Brochure

ABOUT US

---

Version: Draft (0.11) Status: Checked in and viewable by authorized users. Publication Start Date: Immediately

Page | Workflow | Tools | Edit Page | Submit for Approval

---

Home > Products > Compressors > Scroll Compressors > Refrigeration > CO2 Compressors

**COMMERCIAL**

**REFRIGERATION**

Copeland Digital Scroll For Refrigeration

**CO2 Compressors**

**RESIDENTIAL**

### CO2 Compressors

Emerson Climate Technologies offers the Copeland Scroll® ZO compressor which has been designed to take advantage of the characteristics of a R744 (CO<sub>2</sub>) refrigeration system.

**No Potential Environment Hazard**

- Capitalizes on the unique non-ozone depleting, non-flammable, low global warming potential properties of CO<sub>2</sub> refrigerants;
- Takes advantage of CO<sub>2</sub>'s excellent thermal properties and utilizes it as a secondary coolant to reduce hydrofluorocarbon (HFC) usage.

**Compact, Lightweight Design**

- 30% to 60% lighter than other reciprocating piston compressors of similar capacity;
- Eliminates refrigerant leakage;
- Enables easier transport, installation and maintenance.

**Designed for CO<sub>2</sub> Pressure and Lubrication Requirements**

- Encased in strong steel shell tested to withstand high pressure levels;
- Copes with higher mass flow by not utilizing suction and discharge valves;

EMAIL THIS PAGE

Why Register Here? Click to Register Forgot Password

## news release

ABOUT US

---

Version: Draft (0.11) Status: Checked in and viewable by authorized users. Publication Start Date: Immediately

Page | Workflow | Tools | Edit Page | Submit for Approval

---

Home > Products > Compressors > Scroll Compressors > Refrigeration > CO2 Compressors

**COMMERCIAL**

**REFRIGERATION**

Copeland Digital Scroll For Refrigeration

**CO2 Compressors**

**RESIDENTIAL**

### CO2 Compressors

Emerson Climate Technologies offers the Copeland Scroll® ZO compressor which has been designed to take advantage of the characteristics of a R744 (CO<sub>2</sub>) refrigeration system.

**No Potential Environment Hazard**

- Capitalizes on the unique non-ozone depleting, non-flammable, low global warming potential properties of CO<sub>2</sub> refrigerants;
- Takes advantage of CO<sub>2</sub>'s excellent thermal properties and utilizes it as a secondary coolant to reduce hydrofluorocarbon (HFC) usage.

**Compact, Lightweight Design**

- 30% to 60% lighter than other reciprocating piston compressors of similar capacity;
- Eliminates refrigerant leakage;
- Enables easier transport, installation and maintenance.

**Designed for CO<sub>2</sub> Pressure and Lubrication Requirements**

- Encased in strong steel shell tested to withstand high pressure levels;
- Copes with higher mass flow by not utilizing suction and discharge valves;

EMAIL THIS PAGE

Why Register Here? Click to Register Forgot Password

