

ACCESSORY KIT INSTALLATION INSTRUCTIONS

DIRTY FILTER SWITCH (DFS) 2DF0402

FOR USE WITH *Simplicity™ INTELLI-Comfort™ AND MOD LINK*

GENERAL

The following instruction provides all the necessary information to install the Dirty Filter Switch Kit.

The Kit includes the following:

- 1 ea. Dirty Filter Switch
- 1 ea. 54" - 1/4" Clear Tubing
- 2 ea. Drill Screw #10-16
- 1 ea. Dirty Filter Switch Mounting Plate (15-25 Ton)
- 1 ea. Dirty Filter Switch Mounting Plate (3-6 Ton)
- 1 ea. Dirty Filter Sample Tube

INSTALLATION

DETERMINE INTO WHICH UNIT THE KIT IS TO BE INSTALLED.

- 3-6 Ton with *Simplicity™ INTELLI-Comfort™* with and without Mod Link
- 6.5-12.5 Ton with *Simplicity™ INTELLI-Comfort™* with and without Mod Link
- 15-20 Ton with *Simplicity™ INTELLI-Comfort™* with and without Mod Link

3-6 TON WITH *Simplicity™ INTELLI-Comfort™* WITH AND WITHOUT MOD LINK

1. Disconnect all electrical power to the unit.
2. Remove the filter access panel.
3. Attach the Dirty Filter Switch to the mounting plate (3-6 Ton) provided in this kit.
4. Attach the Dirty Filter Switch and mounting plate assembly on the coil support using two drill screws. See Figure 1.

NOTE: Use caution when drilling around the coil.

5. Cut and route 12" of 1/4" clear tube, from the Dirty Filter Switch "HIGH or Unmarked" port around the filters to the return air section.

6. Tubing should hang freely in the return air section.
7. Leave the "LOW" pressure port on the Dirty Filter Switch open.
8. Connect the wires from the factory installed harness to the Dirty Filter Switch, per the wiring diagram provided with the original unit

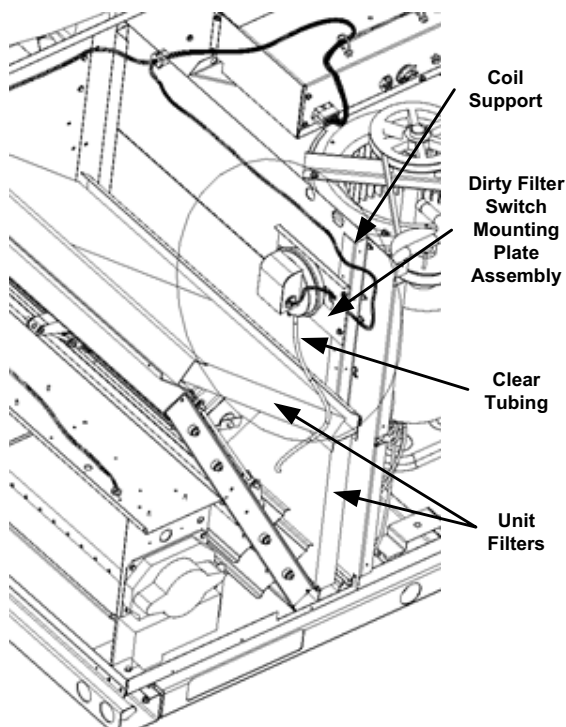

FIGURE 1

6.5 - 12.5 TON WITH *Simplicity™ INTELLI-Comfort™* WITH AND WITHOUT MOD LINK

1. Disconnect all electrical power to the unit.
2. Remove the upper economizer panel. See location of switch in Figure 2.

3. Locate the Dirty Filter Switch on the compressor partition panel and secure with two #10-16 drill screws.

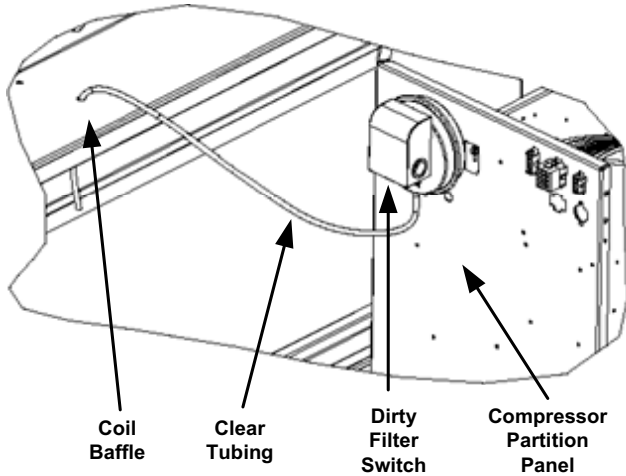

FIGURE 2

4. Connect the 1/4" tubing to the "LOW" pressure port of the Dirty Filter Switch.
5. Route the tubing along the top of the unit, over the filter rack and through a hole in the top of the coil baffle. Tube should hang loose approximately 6" below the top of the coil support.
6. Leave the "High or Unmarked" port of the switch open (without tube).
7. Connect the wires from the factory installed harness to the Dirty Filter Switch, per the wiring diagram provided with the original unit.

15-25 TON WITH Simplicity™ INTELLI-Comfort™ WITH AND WITHOUT MOD LINK

1. Disconnect all electrical power to the unit.
2. Remove the outdoor air and filter access panels and loosen the roof of the unit in the evaporator coil area to provide clearance over the air filter rack.
3. Attach the Dirty Filter Switch to the mounting plate (15-20 Ton) provided in this kit.

4. Attach the Dirty Filter Switch and mounting plate assembly to the base as shown in Figure 3.

NOTE: Use existing base pan screws.

5. Place the dirty filter sample tube over the air filter rack. (See Figure 3)

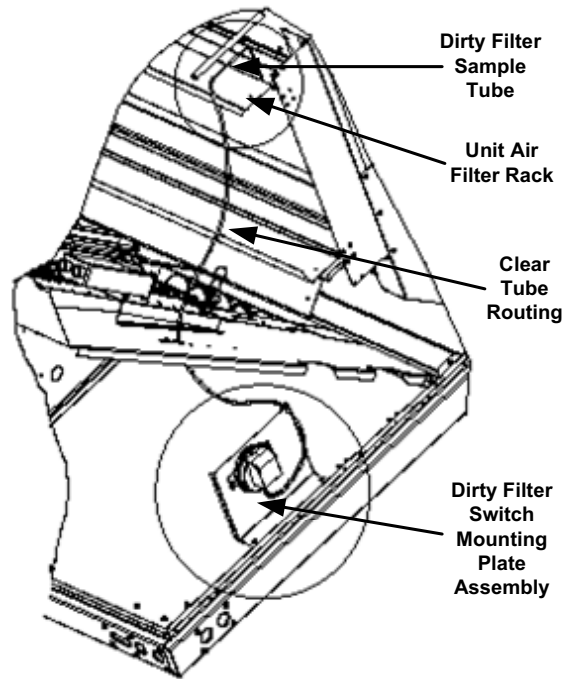

FIGURE 3

6. Connect one end of the 54" long 1/4" clear tubing to the end of the sample tube placed over the coil support.
7. Route the tubing through the economizer panel as shown in Figure 3.
8. Connect the 1/4" clear tubing to the "LOW" pressure port of the Dirty Filter Switch.
9. Leave the "High or Unmarked" port of the switch open (without tube).
10. Connect the wires from the factory installed harness to the Dirty Filter Switch, per the wiring diagram provided with the original unit.