



# TECHNICAL APPLICATION AND PROGRAMMING GUIDE

## SERIES 40 SINGLE PACKAGE ROOFTOP UNITS 25, 30 & 40 TON EQUIPPED WITH STANDARD CONTROLS



## SERIES 40, 25-40 TON SINGLE PACKAGE COMMERCIAL ROOFTOP UNIT EQUIPPED WITH STANDARD CONTROLS

This manual includes application, programming and service procedures for the Series 40, 25-40 Ton Single Package Commercial Rooftop Unit equipped with standard controls. These procedures are the same for all 25-40 Ton Rooftop units in this series except as noted.

This manual covers standard controls only, for unit installation information please refer to the following.

## RECOMMENDED TECHNICAL AND INSTALLATION AIDS

Series 40, 25-40 Ton Single Package Installation and Operation Manual - 350333

Series 40, 25-40 Ton Technical Guide - 355279



ISO 9001  
Certified Quality  
Management System

## TABLE OF CONTENTS

<b>SERIES 40, 25-40 TON SINGLE PACKAGE COMMERCIAL ROOFTOP UNIT EQUIPPED WITH STANDARD CONTROLS</b> .....	<b>1</b>
<b>RECOMMENDED TECHNICAL AND INSTALLATION AIDS</b> .....	<b>1</b>
<b>THE SERIES 40 UNIT CONTROL</b> .....	<b>3</b>
INTRODUCTION AND OVERVIEW .....	3
DIGITAL LINGO .....	4
ANALOG TO DIGITAL CONVERTER .....	4
COMMUNICATIONS BUS .....	5
COMPONENT DESCRIPTION .....	5
<b>SERIES 40 PROGRAMMING OPTIONS</b> .....	<b>11</b>
INTERACTING THROUGH THE SERIES 40 UNIT CONTROL .....	11
INITIAL STARTUP OPTIONS .....	11
METRIC OPERATION (ENGLISH) .....	11
<b>SETTABLE SYSTEM PARAMETERS</b> .....	<b>11</b>
<b>SERIES 40 SEQUENCE OF OPERATION</b> .....	<b>18</b>
OVERVIEW .....	18
RUN SEQUENCE .....	18
UNIT CONTROLS SEQUENCE .....	18
VARIABLE AIR VOLUME UNIT (VFD & IGV) .....	20
OCCUPIED / UNOCCUPIED / MORNING WARM-UP .	20
UNIT CONTROLS .....	21
HEAD PRESSURE CONTROL .....	24
SEQUENCE OF OPERATION - FOR HEAD PRESSURE CONTROL .....	24
INTELLI-START .....	24
DEVICES AND RULES .....	24
COMFORT VENTILATION MODE .....	25
HYDRONIC HEAT .....	26
COOLING LOCKOUT ON OAT .....	27
WATER COIL FREEZE STAT (FSI) .....	27
CV OPERATION .....	27
THERMOSTAT OPERATION FOR COOLING WITH Y1, Y2, Y3 AND Y4 INPUTS .....	27
OPERATION FOR HEATING WITH W1, W2, AND W3 INPUTS .....	28
SENSOR OPERATION .....	28
TYPES OF SPACE SENSORS .....	28
VAV OPERATION .....	29
SUPPLY DUCT PRESSURE CONTROL ALGORITHM .....	31

MORNING WARM UP / VAV OCCUPIED HEATING CONTROL ALGORITHM .....	31
CONTROLLING EXCESSIVE SAT (SUPPLY AIR TEMPERATURE) .....	33
SAT SETPOINTS USED DURING COOLING WITH ECONOMIZER OPERATION .....	33
DEMAND VENTILATION .....	36
EXHAUST OPERATION .....	37
SCHEDULING OPERATION .....	38
COMPRESSOR STATUS MONITORING .....	38
<b>TROUBLESHOOTING A SERIES 40 UNIT CONTROL</b> .....	<b>40</b>
STATUS LED CHART .....	40
FAILURE MODES AND DEFAULT OPERATION .....	40
SENSOR FAILURES AND DEFAULT OPERATION .	40
SYSTEM ERRORS .....	41

### LIST OF FIGURES

<u>Fig. #</u>		<u>Pg. #</u>
1	Series 40 Controller .....	3
2	Units Controls Push Buttons .....	3
3	Analog to Digital Converter .....	4
4	VFD Control Wiring .....	8
5	VFD Control Wiring .....	14
6	VFD Control Wiring .....	25
7	VFD Control Wiring .....	31

### LIST OF TABLES

<u>Tbl. #</u>		<u>Pg. #</u>
1	Acronyms .....	6
2	Input Signal To Y1 Actuator Position .....	8
3	Series 40 Control Inputs .....	9
4	Series 40 Control Outputs .....	10
5	Settable System Parameters .....	16
6	Cooling Stage .....	19
7	Compressor Minimum Off Times .....	27
8	Weekly Schedule .....	32
9	Holiday Schedule .....	32
10	Alarm Default Codes .....	39
11	Status Led Chart .....	40

## THE SERIES 40 UNIT CONTROL

### INTRODUCTION AND OVERVIEW

Welcome to the new Series 40 unit control, a digital control system designed specifically for the 25 to 40 Ton Series 40 single package rooftop unit. The control is composed of 72 monitored and controlled input and output points. The control logic of the Control Board extends on the rules built in to the Synthesys control, and provides character displays in addition to LED flashes to display information to the technician.

This digital control performs all of the control and monitoring functions that were originally done by separate discrete relays, controls, and interlocking hardware. This reduces manufacturing, service, and maintenance costs. The digital controller includes sophisticated control of the individual components of the HVAC cooling/heating unit, and has built-in rules that protect those components and optimize the control to its environment. The cooling and heating modes are protected against frequent cycling, slugging, multiple restarts, etc.



**Figure 1: Series 40 Controller**

One result is that the system may not immediately respond as you expect. For example, internal digital timers may delay the start of a compressor even though the thermostat calls for cooling. The control may be in the middle of a timing sequence; without the observer knowing what has already happened and the status of current inputs, the system may take action not expected by the tech.

In the unit control, there are:

- a list of user-selected option settings and setpoints recorded within the control;
- inputs monitored by the control;
- specific fixed rules and timings built in to the control
- outputs to compressors, heat, economizers, and other options.

The control has a real-time clock function, with minimum of ten hours 'Time-of-day retention' with unit power off.

The Series 40 unit control is resistor-configured for Constant Volume (CV) units or Variable Air Volume (VAV) units. The option settings for a specific option configuration will be made as part of unit test at the factory; however, if there is doubt about how a unit is responding in the field, check the option setting for the unexplained action.

If connected to a network, the control requests an address by a press of the Address/Down button.

### DIAGNOSTICS VIA LED

There is an LED on the board that shows the status of the control and alarms (see Status LED Table). There are two character displays, one 2-digit and one 4-digit, to indicate details of run conditions and alarms (see Alarms Table in the Trouble Shooting section of this manual).

When the Alarm / Change Data button (See Figure 32 Unit Controls Push Buttons) is pushed and released one time within five seconds, it will re-enunciate the last five alarms on the Display.

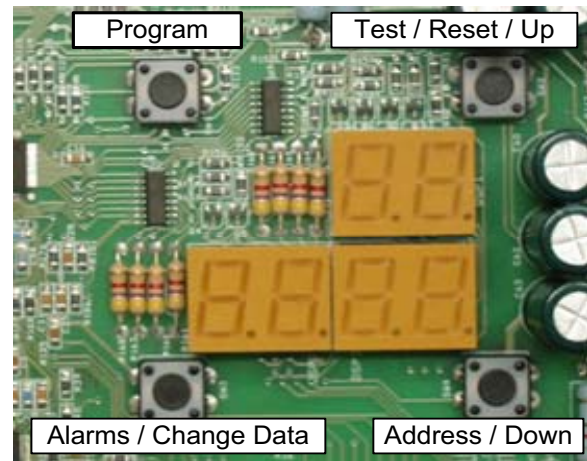

**Figure 2: Units Controls Push Buttons**

When this button is pushed and released two times within five seconds, it will clear all stored alarms.

The error details for most conditions are stored in summary in the unit control and can be accessed by the digital display, personal computer interface, or Palm Pilot (Some interfaces still in development).

Diagnosing requires patience because of internal timings. Normal observable conditions are the same - contactor 1M pulled in, compressor 1 running - but the control does not identify what it has just done or is about to do. The control will take action according to its internal rules even though action requests come from smart thermostats. A call for cooling, for example, will be compared with supply air temperature before energizing a cooling stage.

## ERROR HISTORY

The control stores up to 5 of the most recent alarms in a First In, First Out (FIFO) manner. As the control collects alarms, it will overwrite the oldest alarm after the history buffer becomes full.

Some system errors will initiate a controlling response as well as being stored in the error memory buffer. See the “Troubleshooting” chapter in this manual for a detailed description of how controller errors are handled.

Data items stored for maintenance / run history, in addition to Alarms:

- Accumulated run times for each compressor and heat stage
- Unit model number
- Unit serial number
- Unit Name

## DIGITAL LINGO

This training manual is intended to help you with the commissioning process by illustrating the use of tools like the control’s digital input and software engineered specifically for starting up and servicing a Series 40 rooftop unit.

You should become familiar with some common terminology and lingo used in the digital controls industry. [If you are familiar with the Synthesys controller, the logic of the unit control will be familiar territory.]

If this is your first exposure to the world of digital controls you may experience a lot of new terms, acronyms and technical lingo commonly used in the controls industry. For example, the control input and output hardware points are described as **analog**, relating to a continuous scale of value readings such as a temperature sensor ranging from  $-40^{\circ}\text{F}$  to  $160^{\circ}\text{F}$  range, or **binary**, meaning 2-states, either on or off, open or closed, true or false, one or zero. The term “digital” also means two states and its use is often interchanged with “binary”. These points may be either factory- or field-set.

## THE PI ALGORITHM

Another common “digital controls” term is the PI algorithm or Proportional-Integral control loop. The PI algorithm is a continuously updated math calculation that the controller uses to modulate an analog output point. For example, a variable speed drive uses a PI loop to maintain a desired setpoint (in this case, a duct static pressure value). The algorithm takes into account several parameters to calculate the output. The PI loop needs parameters such as the proportional operating bandwidth, integral time constant, deadband, desired setpoint value, sensed input value(s), start up ramp time, initial start value, maximum output control value, a status point to initiate the control action (i.e. a fan ON status), Direct or Reverse Controlling Action, and several other parameters to calculate a simple 0 to 100% analog output control. The PI algorithm is also called a PI loop because it “loops” the output back to the input (feedback) and determines a new output value based on the

“error” or difference between the setpoint value and the sensed input value, and how that difference relates proportionally to the 0 to 100% output value. Time is the “integral” constant that is factored in to increase or decrease the controlling output action depending on how long the sensed value remains away from its desired setpoint.

Fortunately, you do not have to determine all of these parameters since they are pre-programmed at the factory. You need only to set a desired setpoint and ensure that the inputs and outputs are properly wired and working. This is referred to as commissioning a system.

## ANALOG TO DIGITAL CONVERTER

Computers can only understand a simple binary language. Remember, “binary” means two states - ON or OFF. Analog (continuous) values of voltages, currents, and resistances are supplied by sensors and transducers to the control. These values must be converted in to a binary code so that the computer can understand them. This conversion process is performed through a combination of hardware and software. For example, the 0-5VDC analog value from a static pressure transducer is divided into thousands of steps with a binary coded number, often called “counts”, assigned to each step.

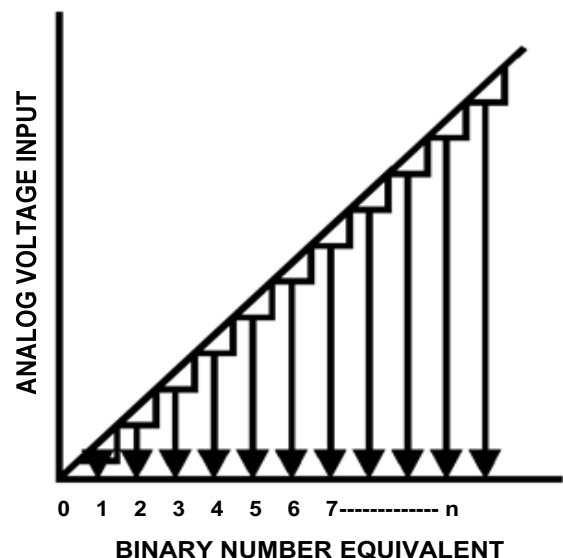

Figure 3: Analog to Digital Converter

## SOFTWARE TERMINOLOGY

A digital controller handles its control functions through software programming rather than with interlocking hardware and wiring. The software then becomes key to how controlled functions are handled. Software is a set of statements (referred to as the “program”) that define the function of the controller’s internal microprocessor computer.

Software procedurally tells the computer the sequence and order of tasks that need to be performed using a language that the computer can understand.

Software is stored in a computer's memory. There are several types of memory in a computer. Each type has a specific function to perform.

**EPROM** - This is "nonvolatile" memory, meaning it will not be erased on a power loss. This memory is usually programmed prior to assembly of the controller. Since this memory is not changed during normal operation of the control, only basic operation instructions are stored in this type of memory.

**EEPROM (Double "E" Prom)** - Is also non-volatile, but this type of memory requires a special process to be written to. This memory can be written to and changed by the microprocessor. This is the type of memory that the control program is stored in the control.

**ROM** - Read Only Memory is non-volatile but can not be written to. This memory is programmed only once before the controller is assembled. ROM contains instructions specifically for the internal microprocessor computer in the controller.

**FIRMWARE** - "Firmware" is software, program instructions or applications, but stored in EPROM or ROM memory.

**RAM** - Random Access Memory is a volatile memory. It will be erased when a power fail occurs. This memory is used as a kind of "scratch pad" for the controller. Temporary instructions and information such as an output controlling action like driving the economizer dampers open is stored here. When a power loss occurs or if the controller is sent a manual reset using a control push button, this memory is cleared and initialized.

Other filtered inputs include temperature and humidity sensors. You should be aware of this filtering effect because it will appear the controller is not acting as fast as you may think it should. In reality, it is acting and controlling on these time-averaged and weighted values.

**FAULT TOLERANCE** - Fault Tolerance of the control involves two issues: Hardware fault tolerance deals specifically with the electrical characteristics of the controller - how much over voltage or power surge the controller can withstand before damage occurs, and whether internal comparisons are verifying that the control is calculating and communicating properly. Software fault tolerance in this technology consists of comparing results to previous values and to reasonable values.

## COMMUNICATIONS BUS

Networked communications may also be new to you. It relates to connecting several Millennium rooftop units to a network that can be monitored and controlled remotely from network computer workstations. You will find this typically on large installations where central control, monitoring, and energy management issues become a critical factor in operating a large complex such as a manufacturing facility.

The Control has the ability to be networked into a larger system using the MODBUS communication protocol. A communication protocol is simply a set of rules that determine how two systems communicate with each other over some medium such as a pair of wires, phone line, radio waves, etc. The transmission medium may also be called a gateway, pathway, or bus. An "open" protocol such as MODBUS is a publicly published set of rules that any equipment manufacturer can use to network into another manufacturers equipment.

## COMPONENT DESCRIPTION

This section describes the main components of Series 40 unit control. These components consist primarily of controllers, hardware to handle signal input and control output and the Tstat interface terminals.

## THE UNIT CONTROLLER

The Series 40 control is a proprietary, microprocessor-based controller for use in HVAC applications. The controller provides monitoring and control for either VAV or CAV for a total of 22 outputs.

## WIRING AND TERMINATION, COMMUNICATIONS

Most connections to the control are by wiring harnesses. There are also screw terminal connections for thermostat inputs and for communications via an RS-485 port.

## COMMUNICATION ADDRESS

The communication address button (lower right of the display) is used to identify a Series 40 rooftop unit to a network, and "capture" the next available network address for that unit. Millenniums can be networked together for centralized monitoring and control. Much like we need a unique street address in our homes so we can receive our postal mail or emergency services, these units also need a unique address so the central Facilities Management System (FMS) can "talk" to each unit individually. The board has the model and serial number of the specific unit and has a memory space for a customer name to be applied. So the entire identification for a specific unit available to the network could be, for example, T2AC04M3KDGABA, NCNM123456, SOUTH OFFICE.

The one-time commands to Override ASCD timers and/or to start Run Test can be issued by the Test/Reset/Up pushbutton. When this button is pushed and released within five seconds, the control will zero all ASCD's for one cycle.

## ACRONYMS

A number of acronyms are used throughout this training manual. These are specific to the control. They are also used in the Technical Guide and Installation and Operation manuals. Acronyms are used to refer to input and output hardware points and software parameters such as timing delays and setpoints.

**Table 1: Acronyms**

Inputs	Description
APS	Air Proving Switch
IAQ	Air Quality (CO2 Sensor)
BAS Economizer	Passes BAS economizer command through to Economizer output
BPS	Building Pressure Sensor
C10-C40	Compressor Status
DF	Dirty Filter Status
DPS	Duct Pressure Sensor
FSI	Hot Water Coil Freeze Input
G	Thermostat input for Fan
GV1-3	Monitors gas valve actuation call
HPS1-4	High pressure switch monitored for compressor discharge
LPS1-4	Low pressure switch monitored for compressor suction
Lim 1-3	Over-temperature limit switch from heat stages
OAT	Outside Air Temperature
OCC	Building Occupied Status
Purge	Building Purge input
RAT	Return Air Temperature
SAT	Supply Air Temperature
SD	System Shutdown Connector
OAH	Outside Air Enthalpy
RAH	Return Air Enthalpy
SSA	Setpoint Adjust
ST	Space Temperature
W1, 2, 3	Heating Stages from Tstat
Y1,2 3, 4	Cooling Stages from Tstat
Pushbuttons	Description
Test/Reset / 'Up	'Test / control reset / Data value increment
Address / 'Down	'Change data / Data value decrement
Alarms / Advance data	Show alarms / go to next data point
Program	Go to program mode
Real Time Clock	Incorporated on the board
Outputs	Description
Status LED	Flash to indicate alarm, otherwise 'heartbeat'
Digital displays	One 2-character and one 4-character
C1-C4	Cooling Outputs 1 through 4
CF1, 2	Cond Fan Bank 1, 2
ECO	Economizer damper output
EXH	Exhaust Fan relay output
EXD	Exhaust Air Damper / Exhaust VFD Signal Output
Fan	Supply Fan relay output [contactor or permission relay]
H1, 2, 3	Heating Stages 1, 2, and 3 output
HGR	Hot gas reheat [future]
HWV	Hot Water Valve output
VFD	Supply Fan IGV or VFD Signal Output
X	Alarm signal

**Table 1: Acronyms (Continued)**

Miscellaneous	Description
AI	Analog Input
AO	Analog Output
BI	Binary Input same as
BO	Binary Output
CAV	Constant Air Volume
VAV	Variable Air Volume
VFD	Variable Frequency Drive
IGV	Inlet Guide Vane
IAQ	Indoor Air Quality
PI	Proportional-Integral Control
ASCD	Anti Short Cycle Timer (Compressor)

The acronyms used throughout this training manual are listed in the Acronym Table 1. They are described in much more detail below.

## INPUTS

There are two types of hardwired input points on the control: Analog and Binary. These may be sensors, feedback, or adjustable setpoints. Typical analog inputs [AI] include Space Temperature (ST), Supply and Return Air Temperatures (SAT, RAT), and Building Pressure Sensor (BPS). The binary inputs (BI) on the Series 40 unit control use a dry contact input to determine the status of a monitored point. Typical BI points are Fan Status (APS), Filter Status (DFS), and Compressor Status (HPS1-4, LPS1-4, C10-40).

## ANALOG INPUTS (AI):

Analog inputs require parameters that define the input's characteristics. Attributes of an AI include the linear range, alarm limits, alarm differential, change of state (COS) enable, and filter weight. The input values may be overridden by an external system command or by using the input buttons on the board. This is useful to override current conditions to test certain control functions or modes.

**BAS** - Economizer override; if this option is enabled, an external BAS system will control the economizer 2-10 VDC signal through this pair of terminals.

**ST** - Space Temperature sensor is a field installed sensor (PN: 025-38928-000 - w/ Override Button). The sequence of control for space temperature is different depending on whether the system is a VAV or CAV. See chapter on Sequence of Operation for a detailed description of the ST control modes.

**SSA** - Space Temperature Adjust is field installed. It is a slide adjustment located on a space sensor (PN: 025-38927-000) with a slide bar potentiometer. It is used to offset the space temperature setpoint. This slide-bar is a 10K ohm potentiometer. The programmable range for the Setpoint adjust is +/- 5 °F. For example, if the Space Temperature setpoint is set to 74 °F, the SSA is programmed to +/- 3 °F and the SSA is adjusted fully to the + position, the new controlling space setpoint will be 78 °F.

**OAT** - The outside air temperature sensor (PN: 031-01916-000A) is a factory-installed 10 K NTC sensor. Its linear ranging is from -50 °F to 250 °F.

**OAH** - Outside Air Humidity (PN: 031-09127-000-A) is a factory-installed sensor manufactured by MAMAQ. The OAH sensor, installed only with enthalpy economizer, provides a 0-10 VDC signal to the controller over a range of 0 to 100% relative humidity. This input is used for the economizer calculation to determine whether free cooling is available and to switch between minimum outside air and using outside air as the first stage of cooling.

**SAT** - Supply Air Temperature sensor (PN: 031-01915-000A) is a factory-installed -50 °F to 250 °F, 10 K NTC sensor.

**RAT** - Return Air Temperature sensor (PN: 031-01917-000A) is a factory-installed -50 °F to 250 °F, 10 K NTC sensor.

**RAH** - Return Air Humidity (PN: 031-09127-000-A) is a factory-installed sensor manufactured by MAMAQ, installed only with dual enthalpy economizer. The control will calculate the return air enthalpy using the relative humidity and return temperature inputs.

**LOW VOLTAGE DETECTION** - This input monitors the 24 VAC for low voltage conditions. The input has two thresholds, one at 16 VAC and one at 19.2 VAC. If the control needs to turn on a contactor, it will look to see if the voltage is above 19.2 VAC before it will turn it on. If the voltage is not above 19.2 VAC, it will hold off the contactor and flash the appropriate flash code. This flash code is not an alarm. If the control already has contactors pulled in, it will monitor the voltage and drop the contactors and shut down if the voltage drops below 16 VAC and flash the appropriate flash code.

**REMOTE** - the control will use 0-10 VDC from third-party BAS to control SAT setpoints. Thermostat inputs override if in conflict with Remote Control voltage input.

**SPC TEMP** - offset value from the space sensor offset potentiometer.

**CV/VAV** - resistive value across terminals, to determine which supply fan rules the control will follow.

**Demand Ventilation / IAQ** - Indoor Air Quality. The IAQ expects a 0-10 VDC signal to the control from a field supplied and installed Carbon Dioxide (CO<sub>2</sub>) sensor. Indoor air quality is monitored for adequate ventilation. In Demand Ventilation Mode, as the CO<sub>2</sub> levels in the building rise above the programmed setpoint, more fresh air must be brought in. The economizer is therefore adjusted to a more open position as necessary. The linear ranging for IAQ sensor input is from 0 to 10,000 ppm. The Demand Ventilation setpoint is adjustable from 0 to 2000 ppm and is set at the factory at 1000 ppm.

**DPS** - Duct Pressure Sensor is monitored by a factory-installed 0-5 VDC transducer (PN: 031-01209-000A). The high-pressure port sensing tube is installed in the field. The sense tube should be located approximately two thirds of the way down the duct plenum. To prevent an unstable signal due to air turbulence, there should be no obstructions, turns or VAV terminal boxes up or down-stream of the sense tube

location for at least 6 to 10 times the diameter of the duct. The sensor is located in the control box just below the Series 40 unit control.

**BPS** - The Building Pressure Sensor (PN: 031-01262-000A) is a factory-installed Johnson Controls DPT-2640-522 transducer that provides a 0 to 5 VDC signal to the controller over a range from -0.25"WC to +0.25"WC. The transducer is located in the control box just below the Series 40 unit control. The sense tubes are field installed with the outside pressure being sensed external to the unit. To avoid an erratic pressure reading, the building pressure sense tube should be mounted in an area away from the return air grill, discharge diffusers, doors and windows.

#### **BINARY INPUTS (BI):**

**APS** - Supply Fan status is monitored by an Air Proving Status switch (PN: 024-27557-000A) installed at the factory. The APS monitors the difference in pressure between the suction and discharge of the fan.

**C10 through C40** - These four binary inputs report the status of the Compressors 1 through 4 overload modules.

**FOVR** - Monitoring loop through the supply fan overload module.

**HPS1-4, LPS1-4** - The refrigerant high pressure (HP) and low pressure (LP) safety switches, are independently monitored by the Series 40 control. If any switch opens, the control voltage from the control binary output is interrupted and the status is monitored by the control.

**G, OCC, P** - These signals represent Fan (G), Building Occupancy (OCC), and Building Purge (P) calls from the thermostat. If a thermostat is installed on the system, these inputs are connected to the thermostat interface board just as are the cooling/heating calls. These inputs are connected through the Tstat Interface board directly to the respective binary inputs of the Controller. These signals are, however, each loaded with a resistor to maintain voltage levels and to prevent "floating" of signals. Thermostat wiring is typically not shielded and may have induced voltages that could cause errant signal readings by the controller.

**FILT** - Dirty Filter switch [customer supplied, field installed on factory-provided harness connections] input to provide a filter status to the control. The control will alarm only after 24V has been sensed for ten minutes.

**GV1-3** - Monitoring that voltage is being supplied to gas valves on optional heat stages.

**LIM1-3** - Overtemperature inputs from optional heat stages.

**FSI** - Freeze Stat is a customer installed temperature switch on the FSI input to the controller to tell the control that a temperature has occurred that risks the hot water or steam coil.

**Y1-4, W1-3** - If a thermostat is installed on the system, these inputs will take priority over software programmed setpoints and limits.

**SD** - This terminal set allows attachment of an external shutdown NC contact. 24VAC power is supplied to the board at SD2; a factory installed jumper passes that power to terminal R to power the control board. If an external shutdown signal is required at a particular installation, remove the jumper and connect the NC shutdown circuit between SD1 and R.

**OUTPUTS**

**Analog Outputs (AO)** - Analog outputs provide a 2-10 VDC signal to operate controlled devices. The control is currently configured to use only 2-10 VDC outputs to the Variable Frequency Drive, Inlet Guide Vane, Economizer Damper, Power Exhaust Dampers or VFD, and Heating water valves. Since these outputs are analog, they are continuous between 2 and 10 Volts and are proportional to the 0 to 100% drive position of the device.

**ECO** - Economizer Actuator - The modulating Economizer uses a Belimo AF24-SR.9 spring-return actuator (PN: 025-30869-000A). This actuator uses a 2-10 VDC signal to drive the dampers open. The actuator drives 95 degree rotation. Note the chart below for a correlation between the input drive signal at terminal 3 (Y1) of the Belimo actuator and the corresponding output drive position of the damper:

**VFD - Inlet Guide Vane or VFD.** The Inlet Guide Vane uses a Belimo GM24-SR spring-return actuator. This actuator uses the 2-10 VDC signal from VFD+/- terminals to drive the dampers open. The actuator drives 95 degree rotation. Note the chart below for a correlation between the input drive signal at terminal 3 (Y1) and the corresponding output drive position of the guide vane. If the unit has a factory-installed Variable Frequency Drive, the 2 to 10 VDC signal is wired from VFD+/- output directly to the VFD's signal input terminals to control fan motor speed.

**Table 2: Input Signal To Y1 Actuator Position**

Input Signal to Y1	Actuator Position
10 VDC	90 degrees
9	78
8	67

**Table 2: Input Signal To Y1 Actuator Position**

Input Signal to Y1	Actuator Position
7	56
6	45
5	33
4	22
3	11
2	0
0	-5

8VDC over a 90 degree Span = 11.25 degrees/VDC

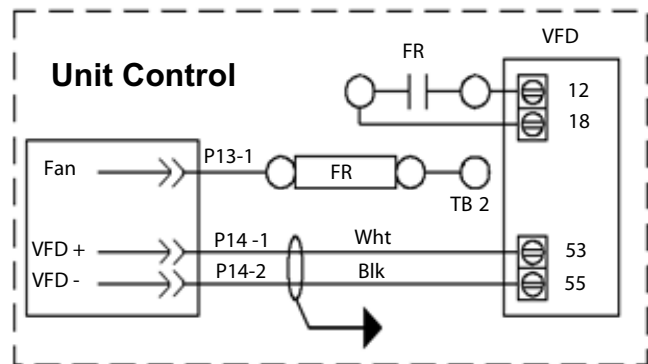

**Figure 4: VFD Control Wiring**

**EXD - Power Exhaust Damper Vane or VFD - Power Exhaust Damper Actuator** is a BELIMO AF24-3-S 24VAC. It uses a full open/ Full Closed scheme and operates a 95 degree rotation. If VFD Power Exhaust is configured, the same signal controls the exhaust fan motor drive frequency.

**HWV - Heating Water Valve** - Customer supplied and installed, connect to factory-provided harness.

**BINARY OUTPUTS (BO)**

**FAN** - Fan Start/Stop Relay, VFD "permission" relay FR

**H1-3** - Heat Stages 1 to 3 [optional]

**C1 through C4** - Cooling Stages 1 through 4

**Table 3: Series 40 Control Inputs**

Name	Range	Resolution	Precision	Description
Y1	18 - 30 VAC	On - Off	+/- .5 VAC	Request for the first stage of Cooling (24 VAC sense) Tstat Screw Terminal
Y2	18 - 30 VAC	On - Off	+/- .5 VAC	Request for the second stage of Cooling (24 VAC sense) Tstat Screw Terminal
Y3	18 - 30 VAC	On - Off	+/- .5 VAC	Request for the third stage of Cooling (24 VAC sense) Tstat Screw Terminal
Y4	18 - 30 VAC	On - Off	+/- .5 VAC	Request for the fourth stage of Cooling (24 VAC sense) Tstat Screw Terminal
W1	18 - 30 VAC	On - Off	+/- .5 VAC	Request for the first Stage of Heating (24 VAC sense) Tstat Screw Terminal
W2	18 - 30 VAC	On - Off	+/- .5 VAC	Request for the second Stage of Heating (24 VAC sense) Tstat Screw Terminal
W3	18 - 30 VAC	On - Off	+/- .5 VAC	Request for the third Stage of Heating (24 VAC sense) Tstat Screw Terminal
G	18 - 30 VAC	On - Off	+/- .5 VAC	Request for the Fan (24 VAC sense) Tstat Screw Terminal
R	18 - 30 VAC	-	-	These terminals are a ¼' Female Faston and a Thermostat Screw Terminal connected to the power supply of the board.
C	Earth Ground	-	-	These terminals are a ¼' Faston and a Thermostat Screw Terminal.
OCC	18 - 30 VAC	On - Off	+/- .5 VAC	Occupied input (24 VAC sense) Tstat Screw Terminal
SD	18 - 30 VAC	-	+/- .5 VAC	Shut Down input Tstat Screw Terminal
Purge	18 - 30 VAC	On - Off	+/- .5 VAC	Building Purge input (24 VAC sense) Tstat Screw Terminal
BAS Economizer	2 - 10 VDC	Not Read by micro	-	Input that routes to the Economizer output Two Tstat Screw Terminals +&-
HPS1	18 - 30 VAC	On - Off	+/- .5 VAC	High Pressure Switch for Circuit # 1 (24 VAC sense)
HPS2	18 - 30 VAC	On - Off	+/- .5 VAC	High Pressure Switch for Circuit # 2 (24 VAC sense)
HPS3	18 - 30 VAC	On - Off	+/- .5 VAC	High Pressure Switch for Circuit # 3 (24 VAC sense)
HPS4	18 - 30 VAC	On - Off	+/- .5 VAC	High Pressure Switch for Circuit # 4 (24 VAC sense)
LPS1	18 - 30 VAC	On - Off	+/- .5 VAC	Low Pressure Switch for Circuit # 1 (24 VAC sense)
LPS2	18 - 30 VAC	On - Off	+/- .5 VAC	Low Pressure Switch for Circuit # 2 (24 VAC sense)
LPS3	18 - 30 VAC	On - Off	+/- .5 VAC	Low Pressure Switch for Circuit # 3 (24 VAC sense)
LPS4	18 - 30 VAC	On - Off	+/- .5 VAC	Low Pressure Switch for Circuit # 4 (24 VAC sense)
Limit Switch 1	18 - 30 VAC	On - Off	+/- .5 VAC	High Limit Switch input (24 VAC sense) For Burner section 1
Limit Switch 2	18 - 30 VAC	On - Off	+/- .5 VAC	High Limit Switch input (24 VAC sense) For Burner section 2
Limit Switch 3	18 - 30 VAC	On - Off	+/- .5 VAC	High Limit Switch input (24 VAC sense) For Burner section 3
GV1	18 - 30 VAC	On - Off	+/- .5 VAC	Gas Valve input (24 VAC sense) For Burner section 1
GV2	18 - 30 VAC	On - Off	+/- .5 VAC	Gas Valve input (24 VAC sense) For Burner section 2
GV3	18 - 30 VAC	On - Off	+/- .5 VAC	Gas Valve input (24 VAC sense) For Burner section 3
Test / Reset / Up	ON - Off	ON - Off	-	Test / Reset Button and Increment Data Input
Address / Down	ON - Off	ON - Off	-	Address Button and Decrement Data Input
Alarms / Advance Data	ON - Off	ON - Off	-	Alarm Button and Advance Data Input
Program	ON - Off	ON - Off	-	Program Button Input
Real Time Clock	24 hours, 365 Days including Leap year and Daylight Savings Time	Seconds	-	Real Time Clock Chip
Water Coil Freeze Stat (FSI)	18 - 30 VAC	On - Off	+/- .5 VAC	Hot Water Freeze Stat (24 VAC sense) two ¼ Fastons
Supply Air Temp Sensor (SAT)	-40° - +180° F	.1° F	-40° - 180°F +/- 2 °F across range	This is a 10KΩ type 3 Thermistor
Outside Air Temp Sensor (OAT)	-40° - +180° F	.1° F	-40° - 180°F +/- 2 °F across range	This is a 10KΩ type 3 Thermistor
Space Temp Sensor (ST)	32° - 100° F	.1° F	.5° F	This is a 10KΩ type 3 Thermistor
Return Air Temp Sensor (RAT)	-40° - +180° F	.1° F	-40° - 180°F +/- 2 °F across range	This is a 10KΩ type 3 Thermistor
Space Setpoint Offset (SSA)	0 - 20 KΩ	1 KΩ	+ and - 250 Ω	3 position Mini Screw Terminal shared with Space Temp The common terminal in the center is common for both the Space Temp and Setpoint Offset.
Building Pressure Sensor (BPS)	0 - 5 VDC - 25 - +25 "WC	.001 "WC	.005"WC 1% Across range	0 - 5 volt input
Duct Pressure Sensor (DPS)	0 - 5 VDC 0 - 5 "WC	.01 "WC	.05"WC 1% across range	0 - 5 volt input
Compressor 1 Overload (C1O)	18 - 30 VAC	On - Off	+/- .5 VAC	Compressor number 1 Overload (24 VAC sense)

**Table 3: Series 40 Control Inputs (Continued)**

Name	Range	Resolution	Precision	Description
Compressor 2 Overload (C2O)	18 - 30 VAC	On - Off	+/- .5 VAC	Compressor number 2 Overload (24 VAC sense)
Compressor 3 Overload (C3O)	18 - 30 VAC	On - Off	+/- .5 VAC	Compressor number 3 Overload (24 VAC sense)
Compressor 4 Overload (C4O)	18 - 30 VAC	On - Off	+/- .5 VAC	Compressor number 4 Overload (24 VAC sense)
APS (APS)	18 - 30 VAC	On - Off	+/- .5 VAC	Air Proving Switch (24 VAC sense)
Fan Overload (FOVR)	18 - 30 VAC	On - Off	+/- .5 VAC	Fan Overload Switch (24 VAC sense)
CV / VAV Input	0 - 20 K $\Omega$	1 $\Omega$	+ / - 5 $\Omega$	Resistive Input 0 - 5.5K = CV 10K - 20K = VAV
Demand Ventilation Input	0 - 10 VDC 0 - 2000 PPM of CO2	1 PPM	20PPM 1% Across Range	0 - 10 volt input
Remote Control	0 - 10 VDC	.05 VDC	0.01	0 - 10 VDC Screw terminal two position Small screw terminal
Dirty Filter Switch (FILT)	18 - 30 VAC	On - Off	+/- .5 VAC	This is the Dirty Filter Switch (24 VAC sense)
Low Voltage Detection	12 - 35 VAC	.1 VAC	.5 VAC	This input monitors the 24 VAC for Low Voltage Detection
Return Air Humidity (RAH)	0 - 5 VDC 0 - 100% RH	.05 VDC 1% RH	.1 VDC 2% Across Range	Scaleable 0 - 10 volts Screw terminal two position Small screw terminal
Outside Air Humidity (OAH)	0 - 5 VDC 0 - 100% RH	.05 VDC 1% RH	.1 VDC 2% Across Range	Scaleable 0 - 10 volts Screw terminal two position Small screw terminal
Comm Port	128 nodes	See Communications	-	Asynchronous Serial Port (RS485) three position Small screw terminal
24 VAC - Class 1	18 - 30 VAC	-	-	¼" quick connect for power to the contactors through the Relays.

**Table 4: Series 40 Control Outputs**

Name	Range	Resolution	Precision	Description
LED	On - Off	-	-	Status LED
Display	7 segment W/ Decimal Point			6 "Seven Segment LED /W decimal point"
H1	Class 1 Relay Contacts	-	-	Heat 1 contactor output (Relay Contacts - 24 VAC/120 VAC)
H2	Class 1 Relay Contacts	-	-	Heat 2 contactor output (Relay Contacts - 24 VAC/120 VAC)
H3	Class 1 Relay Contacts	-	-	Heat 3 contactor output (Relay Contacts - 24 VAC/120 VAC)
C1	Class 1 Relay Contacts	-	-	Compressor number one contactor output (Relay Contacts - 24 VAC/120 VAC)
C2	Class 1 Relay Contacts	-	-	Compressor number two contactor output (Relay Contacts - 24 VAC/120 VAC)
C3	Class 1 Relay Contacts	-	-	Compressor number three contactor output (Relay Contacts - 24 VAC/120 VAC)
C4	Class 1 Relay Contacts	-	-	Compressor number four contactor output (Relay Contacts - 24 VAC/120 VAC)
CF1	Class 1 Relay Contacts	-	-	Condenser Fan contactor output (Relay Contacts - 24 VAC/120 VAC)
CF2	Class 1 Relay Contacts	-	-	Condenser Fan contactor output (Relay Contacts - 24 VAC/120 VAC)
Fan	Class 1 Relay Contacts	-	-	Fan contactor output (Relay Contacts - 24 VAC/120 VAC)
Exhaust Fan (EXH)	Class 1 Relay Contacts	-	-	Exhaust Fan contactor output (Relay Contacts - 24 VAC/120 VAC)
Supply Fan VFD	2 - 10 VDC	-	-	This is a 2 - 10 volt output capable of 10 ma
Exhaust Fan Damper (EXD)	2 - 10 VDC	.1 VDC	.1 VDC	This is a 2 - 10 volt output capable of 10 ma
Hot Water Valve (HWV)	2 - 10 VDC	.1 VDC	.1 VDC	This is a 2 - 10 volt output capable of 10 ma
Hot Gas Reheat	2 - 10 VDC	.1 VDC	.1 VDC	This is a 2 - 10 volt output capable of 10 ma
Economizer (ECO)	2 - 10 VDC	.1 VDC	.1 VDC	This is a 2 - 10 volt output capable of 10 ma
X	24VDC	-	-	This is a 24VDC output for Alarms

## SERIES 40 PROGRAMMING OPTIONS

The paragraphs below provide a definition of, and specify the function related to, each of the parameters that are field-adjustable using the interfaces available. The Series 40 Unit is shipped from the factory with the necessary options pre-programmed as indicated by the model nomenclature. It is always a good practice, though, to verify that the correct parameters are properly configured for the unit you are commissioning. You can find a complete list of field-adjustable parameters in the “**Settable System Parameters**”.

For a description of the parameters, see the **Settable System Parameters below and Table 5**.

### INTERACTING THROUGH THE SERIES 40 UNIT CONTROL

#### SET THE CLOCK

- Power up the unit.
- Press the Program button [upper left].
- Press the Test/Up button [upper right]. Hold it in and it will step through the parameters, or push in to advance one parameter at a time. Advance to parameter 63, Hours.
- Press Change [lower left] Press Up [upper right] or Down [lower right] to the correct hour [24 hour time].
- Press Change to enter the new value.
- Press Up to get to parameter 64, Minutes.
- Press Change.
- Press Up or Down to get to the correct minute value. Press Change to enter the new value.
- If you are done changing parameters, press Program to exit the program mode.

#### PARAMETER SETTING

The buttons allow the operator to go to a specific parameter and to view and change the data in that parameter.

- To enter the parameter setting mode, press the Program button. The control will display the current parameter number in the two-digit display, and the present value of that parameter in the four-digit display.
- To change to another parameter, press the /Up or /Down button to move to the address of the desired parameter. The present value of that parameter will display.
- To change the data, press the /Change button. The value will flash. While it is flashing, press the /Up or /Down button to increase or decrease the value.
- When the desired new value is showing, press the /Change Data button again to tell the control to store the new value. You can verify that the new value is in place when the value stops flashing.
- To exit Program mode, press the Program button again.

#### INITIAL STARTUP OPTIONS

Commissioning a new Series 40 unit installation requires some field adjustments to the control program. Most of these

adjustments simply involve setting up the various setpoints that are specific to your customer's needs (i.e. building pressure) or enabling some extended options that are integrated into the control. Also, if there are field changes, i.e. a modulating power exhaust option, the control configuration will need to be modified for the new option.

#### METRIC OPERATION (ENGLISH)

The factory default for this option is OFF. The metric (SI) conversions are part of the controller software; when the Metric parameter is selected, temperature setpoints and readings will convert to Centigrade (°C).

### SETTABLE SYSTEM PARAMETERS

The following headings list each parameter's name and its default setting. The control is set at the factory for the options of the specific unit; if a replacement control is being installed, the entire parameter set must be matched to the unit. The number in (parentheses) is the value of a parameter in an un-configured control.

**Compressors - (2)** - This tells the control the number of compressors available. The Factory Default [the value in an unconfigured replacement control] is 2 and can be adjusted from 1 to 4.

**Heat Stages - (2)** - This tells the control the number of heating stages available. This parameter may be set from 0 to 3. The default setting is 2 stages of heat.

**Hydronic Heat - (OFF)** - This tells the control that a Hot Water Coil is installed. If the control is going to modulate the Hot Water Valve it will also turn on the Heat One output. This is to energize the VAV heat relay for the VAV boxes. The default is OFF for this option. If this parameter is enabled, remember to set the Hydronic Heat First and Second Stage Setpoints and the Economizer Loading Setpoint found in the “Settable System Parameter Table 5”.

**Stage 1 Hydronic Heat SAT Setpoint - (120 °F)** - When the Hydronic Heat option is enabled, the control will maintain this SAT setpoint for a call for first stage Heating, by modulating the Hot Water Valve. This is the reset temperature when operating a VAV unit in the Heating mode. The reset range for SAT setpoint is from 80 °F to 180 °F with 120 °F shipped as the default.

**Hydronic Heat Reverse Actuated Valve - (OFF)** - This setting is to allow convenient use of reverse acting water valves; setting this parameter to (ON) will change the signal to 2VDC = open, 10 VDC = closed.

**SAT Control for Cooling - (ON)** - This tells the control if it is going to do excessive SAT monitoring and tripping or not, for Cooling. The SAT should be maintained in an acceptable range in order to achieve reliable compressor operation. The compressor trip limits are user adjustable between 40 °F and 65 °F in one degree increments. The default cooling trip limits are 50 °F for stages 2-4, and 45 °F for stage 1. When the SAT drops below the trip limit for each respective compressor, that compressor is locked out and a 5 minute ASCD is initiated for

that compressor. If this option is enabled, remember to set the compressor cooling limits for low limit trip.

**Power Exhaust - (ON)** - This tells the control if it has the Power Exhaust option installed.

**Economizer Damper Position for Exhaust Fan to turn ON (Non-Modulating PE Only) - (60%)** - This tells the control the Economizer Damper position to turn on the Exhaust Fan. This value is based on the 0%-100% output drive signal from the controller to the economizer damper actuator.

**Economizer Damper Position for Exhaust Fan to turn OFF (Non-Modulating PE only) - (20%)** - This tells the control the Economizer Damper position to turn off the Exhaust Fan. This value is based on the 0%-100% output drive signal from the controller to the economizer damper actuator.

**Modulating Exhaust - (OFF)** - This tells the control if the Power Exhaust is Modulating or not. A modulating exhaust will be equipped with a Building Pressure Sensor [BPS]. A Non-Modulating exhaust will look to the economizer damper position to energize the EXD output. If the sensor gets disconnected, or fails, an alarm is set. The alarm can be turned off by correcting the sensor problem (or; by turning off this option). The control is not in this case self-configuring. It will not automatically use the Building Pressure Sensor if the sensor is connected.

**Exhaust VFD Installed - (OFF)** - If the unit has a VFD, the EXD output will be enabled when the supply fan is ON.

**Exhaust Damper Position For The Exhaust Fan To Turn On (Modulating Only) - (80%)** - This tells the control the Exhaust Damper position at which to turn on the Exhaust Fan. This value is based on the 0%-100% output drive signal from the controller to the damper actuator.

**Exhaust Damper Position For Exhaust Fan To Turn Off (Modulating Only) - (20%)** - This tells the control the Exhaust Damper position to turn off the Exhaust Fan. This value is based on the 0%-100% output drive signal from the controller to the damper actuator.

**Building Pressure Setpoint - (+0.100"WG)** - This is the pressure setpoint the control will maintain when operating a Power Exhaust. The Building Pressure Setpoint is adjustable from -0.200"WG to +0.200"WG. The factory programmed default is +0.100"WC. This setpoint is used when the exhaust control is implemented as Proportional Control (with a Modulating Exhaust Air Damper or VFD controlled from building static pressure), or as a Two-position Control using building static (Power Exhaust Fan controlled on-off from building static pressure).

**Economizer - (ON)** - This tells the control that there is an Economizer Installed.

**Economizer Min Position - (20%)** - This tells the control what the minimum outdoor damper position will be for the Occupied mode. Adjustable from 0-100%, the Economizer Minimum Position default is 20%.

**Economizer First Stage Setpoint - (55 °F)** - This tells the control what Supply Air Temperature to maintain for a call for first stage of cooling. This is used only during Constant Volume

cooling mode with Economizer operation. The setpoint is set at 55 °F with an adjustable range from 40 °F to 65 °F.

**Economizer Second Stage Setpoint - (50 °F)** - This tells the control what Supply Air Temperature to maintain for a call for second stage of cooling. This is used only during Constant Volume cooling mode with Economizer operation. This setpoint is set at 50 °F with a range from 40 °F to 65 °F.

**Outside Air Humidity (OAH) Sensor Enable - (OFF)** - This setting tells the control that it is expected to use Outside Air Enthalpy (calculated from Outside Air Temperature and Outside Air Relative Humidity sensed values) to decide if Outside Air can be used for cooling.

The control is self-configuring to the best available decision strategy for free cooling availability. For example, if it detects that OAT and OAH and RAT and RAH sensors are all connected and reliable, will self-configure for Differential Enthalpy operation. If one of the return air sensors should fail, the control will reconfigure for Outside Enthalpy operation, etc.

If the OAH Sensor Enable option is turned ON, it means that the Outside Enthalpy Operation, or better decision strategy, is expected (and supported by installed sensors). If the appropriate sensors are not installed, or one of them failed, a sensor failure alarm is set. The alarm can be turned off by turning off the OAH Sensor Enable option. Thus, the option setting is used to reflect the desired operation and mainly to control sensor failure alarms.

The option setting can be viewed as specifying that (the self-configured economizer decision strategy has to be at least this, or better, otherwise an alarm is set). If the option is OFF, the control still may self configure to Outside Enthalpy Operation, or even to Differential Enthalpy Operation (if all needed sensors are available), but this option setting will allow also the decision strategy based on only OAT (in case other sensors fail, or are not installed) without setting an alarm.

**Outside Air Enthalpy Setpoint - (27 BTU/LB)** - This tells the control an outside air enthalpy limit. Below this limit, outside air is available for cooling. See enthalpy chart. This parameter uses a one BTU/LB hysteresis on each side of the limit. The limit is preset to 27 BTU/LB with an adjustable range from 10 to 50 BTU/LB.

**Return Air Humidity (RAH) Sensor enable - (OFF)** - This tells the control that it will compare Outside Air Enthalpy (calculated from Outside Air Temperature and Outside Air Relative Humidity sensed values) and Return Air Enthalpy (calculated from Return Air Temperature and Return Air Relative Humidity sensed values). The control will use the air stream with the lower enthalpy for cooling.

The control is self-configuring to the best available decision strategy for free cooling availability. For example, if it detects that OAT and OAH and RAT and RAH sensors are all connected and reliable, will self-configure for Differential Enthalpy operation. If one of the return air sensors should fail, the control will stop using rules that involve RAH and set an alarm.

If the RAH Sensor Enable option is turned ON (and supported by installed sensors), Differential Enthalpy Operation can be enabled. If the appropriate sensors are not installed, or one of

them failed, a sensor failure alarm is set. The RAH alarm can be turned off by turning off the RAH Sensor Enable option. Thus, the option setting is used to reflect the desired operation and mainly to control sensor failure alarms.

**Economizer Loading to Control SAT - (ON)** - This tells the control if it is going to use Economizer Loading to control excessive SAT [supplying warmer outside air to keep SAT from going too low]. This parameter is only applicable outside the normal Economizer operation. During the Economizer operation, the loading function is always performed and is an integral part of the control algorithm.

**Duct Static Setpoint - (1.5"WG)** - This parameter is applicable only to VAV mode of operation. This is the pressure setpoint that the control will maintain when operating the fan in a VAV unit. This setpoint is adjustable between 0"WG and 5"WG with the default set to 1.5"WG.

**Duct Static High Limit Setpoint - (4.5"WG)** - This parameter is applicable only to VAV mode of operation. This tells the control at what Static Pressure to shut down the unit due to a Fan control failure. This setpoint is to insure that we don't continue to operate the Fan with an Inlet Guide Vane or VFD problem that could cause the ductwork to fail from duct pressure. When the Static Pressure reaches this setpoint (4.5"WG default), the control will drive the supply fan control output to zero. If the static pressure does decrease below the "Duct Static High Limit Setpoint" within 3 seconds after decreasing the supply fan control output to zero, the control will resume normal operation. If there is no change in static pressure after 3 seconds, the control will generate a High Duct Static alarm, shut down all the outputs including the Fan and shut down the unit. The alarm is written to the Error History Buffer and will trigger storing a snapshot of Points Screen data along with a date and time stamp. In networked applications, the alarm flag is readable by the network. This parameter can be adjusted from 0"WG to 5"WG with the factory default set to 4.5"WG.

The customer must be aware of the duct pressure design limit, and what the duct pressure sensor will be reading when the peak pressure is reached [the pressure pickup tube may not have been located at the place of highest pressure in the system].

The alarm must be reset (after the problem that caused the alarm is corrected) by resetting the controller by turning power to the unit off and back on, or by reset command issued by an external connection.

**Morning Warm Up** - Is inferred from the entries in Occupied/Unoccupied

**Occupied** - (from settings in Weekly Schedule and Holiday Schedule Tables 8 and 9.) - See discussion in Sequence of Operation.

**Unoccupied** - (from settings in Weekly Schedule and Holiday Schedule Tables 8 and 9.) - See discussion in Sequence of Operation.

**VAV High Temperature SAT Setpoint for Cooling - (60 °F)** - The control will maintain this SAT when operating in VAV mode with a thermostat that is calling for first stage cooling. This parameter may be adjusted from 40 °F to 70 °F with 60 °F set as the default value.

VAV Low Temperature SAT Setpoint for Cooling - (55 °F) - The control will maintain this SAT when operating in VAV mode with a thermostat that is calling for second stage cooling. This parameter may also be adjusted from 40 °F to 70 °F with 55 °F set as the default value.

**VAV SAT Reset Setpoint - (72 °F)** - This parameter is used only in VAV mode with a Space Sensor. The control will switch from the VAV Lower Cooling SAT Setpoint to the VAV Upper Cooling SAT Setpoint when this Space Temperature Setpoint minus 0.5 °F is reached. The control will switch from High setpoint back to Low setpoint when the space temperature gets 2 °F above this setpoint. This is SAT reset based on Space Temperature. The reset occurs in both Occupied and Unoccupied modes and may be adjusted from 40 °F to 85 °F. The factory default is 72 °F.

**VAV Occupied Heating - (OFF)** - This option applies in VAV mode with a Space Sensor and does not affect VAV Occupied heating if requested by a thermostat. When this option is toggled on, a VAV unit is able to operate heating in the occupied mode as long as it is operating with a Space Sensor. If the Space Temperature drops to 2 °F below the VAV SAT Reset Setpoint the control will read the RAT. If the RAT is below the Morning Warm Up RAT Setpoint the unit will enter the Occupied Heating mode. Operation is the same as Morning Warm Up. This parameter is factory set to OFF.

**Comfort Ventilation Mode - (OFF)** - Comfort Ventilation is a SAT control mode that controls SAT during "satisfied" periods in a fairly wide temperature band, using mostly Outside Air, and also cooling and heating stages as necessary. It is available only on the Constant Volume unit.

To enable Comfort Ventilation, the programmable parameter "Comfort Ventilation Mode" must be set to ON (default setting is OFF).

For a detailed explanation of Comfort Ventilation, refer to the Sequence of Operation in this manual.

**Comfort Ventilation High Supply Air Setpoint - (80 °F)** - This is the High Limit Setpoint for the Comfort Ventilation mode. For a stable operation of Comfort Ventilation function, the High Supply Air Setpoint should be set 10.0 °F or more above the Low Setpoint.

**Comfort Ventilation Low Supply Air Setpoint - (70 °F)** - This is the Low Limit Setpoint for the Comfort Ventilation mode. For a stable operation of Comfort Ventilation function, the Low Supply Air Setpoint should be set 10.0 °F or more below the High Setpoint.

**Dirty Filter Switch - (OFF)** - This tells the control that a Dirty Filter Switch is connected to it. The control will wait for ten minutes after the switch has closed before declaring a Dirty Filter Alarm. The alarm is written to the Error History Buffer. In networked applications, the error flag is readable by the network. The alarm will automatically reset when the error condition is corrected.

The default is OFF.

**Heating Lockout on OAT - (75 °F)** - This is the Outside Air Temperature Setpoint that the control will use to lock out Heating when the OAT is above this setpoint. There is a one-degree hysteresis on each side of the setpoint. This parameter is adjustable between 0 °F and 100 °F with the default set to 75 °F.

Heating Lockout on OAT affects only staged heating, it does not affect hydronic heat. If the heating is energized when OAT reaches this setpoint, the Status LED will indicate the lockout condition immediately, but the control will finish the heating mode and then lock out the heating.

Note that a Heating Lockout on OAT may occur while the control is in a heating mode and there is a demand for heating.

If the OAT then decreases below the lockout setting while the call for several heat stages exists, the heat stages will turn on simultaneously. This is considered acceptable as this situation is not expected to occur frequently.

**Cooling Lockout on OAT - (45 °F)** - This is the Outside Air Temperature Setpoint that the control uses to lock out Cooling when the OAT is below this setpoint. Adjustable from 0 °F to 100 °F, the default is 45 °F.

**Unoccupied Heating Setpoint - (60 °F)** - This value is the Unoccupied Heating Setpoint. It is used in both CV and VAV mode of operation (in VAV, it controls Unoccupied heating with a Space Sensor).

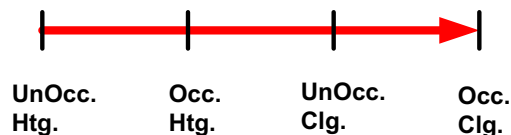

**Figure 5: VFD Control Wiring**

The control will attempt to correct wrong temperature overlap settings; for example, if a change is made that would put Occupied Heating above Occupied Cooling, the Occupied Cooling setting will change to stay above the heating setpoint.

**Occupied Heating Setpoint - (68 °F)** - This value is the Occupied Heating Setpoint. It is used only in CV mode of operation. Its relationship to the related setpoints is as defined in the Unoccupied Heating Setpoint paragraph above.

**Unoccupied Cooling Setpoint - (85 °F)** - This value is the Unoccupied Cooling Setpoint. It is used in both CV and VAV mode of operation (in VAV, it controls Unoccupied cooling with a Space Sensor).

**Occupied Cooling Setpoint - (72 °F)** - This value is the Occupied Cooling Setpoint. It is used only in CV mode of operation. Its relationship to the related setpoints is as defined in the Unoccupied Heating Setpoint paragraph above.

**[Input] FSI (Hot Water Freeze Protection) - (OFF)** - This option is used only on rooftop units with hydronic heat (Hydronic Heat Option is turned ON). Freeze protection should

always be placed on units that use hydronic heating. When the control senses 24VAC, the control will turn on the Hot Water valve to 100%. The control will continue to drive the valve at 100% until five minutes after the switch has opened. Then the valve will revert to normal operation. If the control is operating the Fan, it will close the Economizer fully until the freeze condition is over. If the fan is off and the RAT drops below 40 °F, the Hot Water Valve will turn on 100%.

**Supply AirTemp (SAT) Alarm Setpoint for Cooling - (0 °F)** - If the SAT does not drive below this setpoint when all stages of compression are operating and 10 minutes has elapsed since the last compressor was energized, the control will declare a Cooling SAT Failure Alarm.

The alarm is written to the Error History Buffer. In networked applications, the alarm flag is readable by the network.

The alarm will reset automatically if the SAT does decrease below the setpoint (the alarm condition no longer exists), or when a compressor is turned off (the control does not request all compressors operate). The SAT Alarm Setpoint for Cooling can be adjusted from 50 °F - 80 °F. If the value is set to 0 °F (default) this feature is disabled.

Before the control declares an error, it will read the OAT and the Economizer position. If the OAT is more than 20 °F warmer than the setpoint and the Economizer is open more than 20%, the control will close the Economizer for 10 minutes and then read the SAT. If the SAT falls below the setpoint, the control will declare an Economizer Minimum Position alarm. The control will keep the Economizer closed and finish the Cooling mode. After the Cooling mode has been satisfied, the control will move the Economizer back to the minimum position.

**Supply Air Temp (SAT) Alarm Setpoint for Heating - (0 °F)** - The SAT must drive above this setpoint when all stages of heating are operating and 10 minutes has elapsed since the last stage was energized. If this does not happen, the control will declare a Heating SAT Failure Alarm. The alarm is written to the Error History Buffer. In networked applications, the alarm flag is readable by the network. The alarm will reset automatically if the SAT does increase above the setpoint (the alarm condition no longer exists), or when a heating stage is turned off (the control does not request all heat stages to operate).

The SAT Alarm Setpoint for Cooling can be adjusted from 70 °F - 120 °F. If the value is set to 0 °F (default) this feature is disabled.

Before the control declares an error, it will read the OAT and the Economizer position. If the OAT is more than 20 °F colder than the setpoint and the Economizer is open more than 20%, the control will close the Economizer for 10 minutes and then read the SAT. If the SAT rises above the setpoint, the control will declare an Economizer Minimum Position alarm. The control will keep the Economizer closed and finish the Heating mode. After the Heating mode has been satisfied, the control will move the Economizer back to the minimum position.

**Unoccupied Override Time Period - (60 min)** - The Unoccupied Override Time Limit function will determine how long the unit will operate in the Unoccupied Override mode when the Override button is pressed on the Space Sensor.

Once the Unoccupied Override mode is initiated, it will continue until the programmed Unoccupied Override Time Limit is reached. The Override mode can not be cancelled by, for example, a change of state of the Occupied input to ON (occupied) and then back to OFF (unoccupied).

This parameter is adjustable from 0 to 240 minutes. The default is 60 minutes.

**Fan Delays (ON) & (OFF)** - Any time the control starts a compressor it will load the Fan On Delay for Cool with the programmed value. Any time the control turns off all the compressors it will load the Fan Off Delay for Cool with the programmed value.

When the control turns on a gas heat stage, it will begin monitoring the gas valve and load the Fan On Delay For Heat with the programmed value when it senses gas valve voltage.

When the thermostat terminates the call for W1 the control will turn off H1 output and load the Fan Off Delay for Heat with the programmed value.

After the control has turned on heat, it will start monitoring the Gas Valve. If at any time the Gas Valve (24 VAC) is not present for five minutes while H1 is on, the control will flag an Alarm. Anytime GV1/H1 goes off during the fan on delay, the control will force the fan on, for the fan off delay period. The control will wait for GV1 to be on at least 15 seconds before forcing the fan on. If GV1 has been on for at least 15 seconds, and then goes away before the Fan On Delay has finished, the fan will turn on anyway for a length of time equal to the Fan Off Delay period.

If the control senses this input along with a Y signal, it will not turn on the compressors and it will run the Heating mode. Heating takes priority.

**Fan ON Mode with the Sensor Option - (ON)** - When this option is turned ON, the supply fan will continue running when the zone sensor based temperature control is satisfied. This option applies only in systems using a zone sensor and only in Occupied mode. With this option turned OFF, or in Unoccupied mode, the fan will go off when the zone sensor based temperature control is satisfied and will go on only when there is a call for heating or cooling. Turning this option ON is an equivalent of selecting fan ON (rather than AUTO) in systems with a thermostat. In a thermostat system, the fan control follows the thermostat's G signal. In sensor systems and in the Occupied mode, the fan control follows the Fan ON Mode option.

**Space Sensor Enable - (OFF) (INTERNALLY SET)** - The control will use this input if it detects the device.

**RAT Sensor Enable - (OFF) (INTERNALLY SET)** - The control will use this input if it detects the device.

**Demand Ventilation (ON)** - Setting this parameter on tells the control to expect a signal from a 0-10VDC CO<sub>2</sub> sensor. The default setting for CO<sub>2</sub> is 1,000 ppm.

**Demand Ventilation Setpoint - (1000 ppm)** - This Setpoint is the maximum Indoor Air Quality (IAQ) level that the control will allow. It is adjustable from 700 ppm to 1500 ppm.

**IAQ Sensor Range - (5,000 ppm)** - This tells the control what the full range is for a specific IAQ sensor. It can be changed from 0 to 10,000 ppm.

**Cooling Mode Enable (ON)** - This tells the control if it has Cooling Available (Mode Switch). If this option is turned off, cooling operation is disabled. Note that this parameter does not affect cooling operation in Comfort Ventilation mode.

**Heating Mode Enable - (ON)** - This tells the control if it has Heating Available (Mode Switch). If this option is turned off, heating operation is disabled. Note that this parameter does not affect heating operation in Comfort Ventilation mode.

**Space Setpoint Offset - (3 °F)** - The Space Setpoint Offset is the +/- value the control will use to offset the Space Setpoint when the sidebar Space Sensor is used. For example, if the Space Setpoint Offset value is set to 3.0 °F, shifting the sidebar all the way in minus direction will decrease the Space Setpoint by 3.0 °F and shifting it all the way in plus direction will increase the Space Setpoint by 3.0 °F. It is adjustable from 0 °F to 5 °F.

**ASCD Override** - This is not an option parameter but rather a one-time command issued by pressing the Test / Reset / Up button pressed and released within five seconds; the ASCD's will be set to zero for one cycle.

**Run Test (Commissioning Test)** - This is not an option parameter but rather a one-time command, activated by setting parameter 1 ON.

When the Run Test command is issued, the control will shut the unit down if it is running and then start a Run test sequence:

1. Turn on the Fan and then turn on all the compressors, one at a time, with a 15-second delay between them. Condenser fan #1 turns on with compressor #1, condenser fan #2 turns on with compressor #2. After the last compressor has been turned on, the control will run the compressors for the programmed minimum run time and then turn them all off. Condenser fans are also turned off.
2. The control will then turn on the Heat stages, one at a time, with a 15 second delay between them. The control will run each Heat stage for three minutes and then turn all the Heat off.
3. The control will then open the Economizer to the 100% open position and wait five minutes before closing it to the Minimum Position. When the economizer is at 100%, the exhaust damper will be open to 100% and the exhaust fan runs for 5 minutes, then shuts down.
4. During this Run Test operation the control will read all the installed sensors and verify that their readings are good. If any error is detected the control will display the appropriate error. During the Run Test, the supply fan continues to be monitored via the Air Proving Switch, and a fan failure will cause a unit shutdown.

After the control is finished with the Run Test the normal operation will resume. This command is a good method to use to ensure the control is operating and all input and output points are functional.

**Table 5: Settable System Parameters**

Address	Function	Unit	Range	Default	Your Settings
1	Run test		ON-OFF	OFF	
2	Fan on delay-Heating	Sec	0-30	30	
3	Fan off delay-Heating	Sec	0-255	60	
4	Fan on delay-Cooling	Sec	0-30	0	
5	Fan off delay-Cooling	Sec	0-255	30	
6	Factory setting	-	-	1	Do not change
7	Suspend Cont Fan when starting Heating		ON-OFF	OFF	
8	Construction Mode	-	ON-OFF	OFF	
9	Unoccupied Override Time Period	Minutes	0-240	60	
10	Occupied Cooling Setpoint	°F	45-99	72	
11	Occupied Heating Setpoint	°F	45-99	68	
12	Unoccupied Cooling Setpoint	°F	45-99	85	
13	Unoccupied Heating Setpoint	°F	45-99	60	
14	SAT Control-Cooling	ON-OFF	ON-OFF	ON	
15	Cooling SAT Control Setpoint	°F	40-65	50	
16	SAT Control for Heating	ON-OFF	ON-OFF	ON	
17	Heating SAT Control Setpoint	°F	100-180	135	
18	Hydronic Heating	ON-OFF	ON-OFF	OFF	
19	First Stage Hydronic Heating SAT Setpoint	°F	80-180	120	
20	Second Stage Hydronic Heating SAT Setpoint	°F	80-180	150	
21	Hydronic Heating Reverse Actuated Valve	ON-OFF	ON-OFF	OFF	
22	Remote Control	ON-OFF	ON-OFF	OFF	
23	VAV Upper Cooling SAT	°F	40-70	60	
24	VAV Lower Cooling SAT	°F	40-70	55	
25	VAV SAT Reset Setpoint	°F	40-85	72	
26	VAV Occupied Setpoint	ON-OFF	ON-OFF	OFF	
27	VAV Occupied Heating Setpoint	°F	40-85	68	
28	Morning Warm-Up	ON-OFF	ON-OFF	ON	
29	Morning Warm-Up RAT	°F	50-85	70	
30	Duct Static Setpoint	" H2O	0 – 5"	1.5"	
31	Building Pressure Setpoint	" H2O	neg .25 to .25	.1"	
32	Economizer	ON-OFF	ON-OFF	ON	
33	Economizer First Stage	°F	40-65	55	
34	Economizer Second Stage	°F	40-65	50	
35	Economizer Minimum Position	Percent	0 to 100%	20	
36	Outside Air Humidity Sensor	ON-OFF	ON-OFF	OFF	
37	Economizer Outside Air Enthalpy Setpoint	BTUs Per Pound	10-50	27	
38	Return Air Humidity Sensor	ON-OFF	ON-OFF	OFF	
39	Economizer OAT Enable	°F	40-80	55	
40	Demand Ventilation	ON-OFF	ON-OFF	OFF	
41	IAQ Sensor Range	PPM	0-5000	2000	
42	Demand Ventilation Setpoint	PPM	0-5000	1000	
43	Power Exhaust	ON-OFF	ON-OFF	ON	
44	Modulating Exhaust	ON-OFF	ON-OFF	OFF	
45	Exhaust VFD Installed	ON-OFF	ON-OFF	OFF	
46	Exhaust Damper Position for Exhaust Fan to Turn On (Modulating Only)	% Of Damper Position	0-100	80%	

**Table 5: Settable System Parameters (Continued)**

Address	Function	Unit	Range	Default	Your Settings
47	Exhaust Damper Position for Exhaust Fan to Turn Off (Modulating Only)	% Of Damper Position	0-100	20%	
48	Economizer Damper Position for Exhaust Fan to Turn On (Non-Modulating Only)	% Of Damper Position	0-100	60%	
49	Economizer Damper Position for Exhaust Fan to Turn Off (Non-Modulating Only)	Percent of Economizer Position	0-100%	20%	
50	APS Data	Open-Closed	Open-Closed	Open	
51	Dirty Filter Switch	ON-OFF	ON-OFF	OFF	
52	Dirty Filter Switch Data	Open-Closed	Open-Closed	Open	
53	Cooling Mode Enable	ON-OFF	ON-OFF	ON	
54	Heating Mode Enable	ON-OFF	ON-OFF	ON	
55	Fan On Mode with the Sensor Option	ON-OFF	ON-OFF	ON	
56	Space Setpoint Offset	°F	-5 to 5	0 degrees	
57	Metric Operation	ON-OFF	ON-OFF	OFF	
58	BAS Economizer	ON-OFF	ON-OFF	OFF	
59	Year	Year	00-99	4	
60	Month	Month	Number	1	
61	Day of Month	Day	Number	1	
62	Day of Week	Day	Number	1	
63	Hour	Hour	0-23	0	
64	Minute	Minutes	0-59	0	
65	SAT (Supply Air Temp)	°F	-40 to 180	Read Only	Read Only
66	RAT (Return Air Temp)	°F	-40 to 180	Read Only	Read Only
67	OAT (Outside Air Temp)	°F	-40 to 180	Read Only	Read Only
68	ST (Space Temp)	°F	-40 to 180	Read Only	Read Only
69	OAH (Outside Air Hum)	%RH	0 to 100%	Read Only	Read Only
70	RAH (Return Air Hum)	%RH	0 to 100%	Read Only	Read Only
71	Occupied Input Enable	ON-OFF	ON-OFF	OFF	
72	Alarm Array	These values represent the last 5 alarm codes in memory. 72 is latest & 76 oldest.		Read Only	Read Only
73	Alarm Array			Read Only	Read Only
74	Alarm Array			Read Only	Read Only
75	Alarm Array			Read Only	Read Only
76	Alarm Array			Read Only	Read Only
77	CV/VAV Mode	Read Only Flag	CV=0 VAV=1	Read Only	Read Only
78	Hot Gas Reheat	ON-OFF	ON-OFF	OFF	
79	Hot Gas Bypass	ON-OFF	ON-OFF	OFF	
80	Compressors	Number	2 to 4	Factory Set	
81	Heat Stages	Number	0 to 3	Factory Set	
82	Duct Static Reading	Inches Water	0 to 5.0"	Read Only	
83	Building Pressure Reading	Inches Water	0 to 5.0"	Read Only	
84	Low Ambient Kit Installed	ON-OFF	ON-OFF	Factory Set	
85	Building Static Pressure Sensor Enable	ON-OFF	ON-OFF	Factory Set	
86	ERV Installed	ON-OFF	ON-OFF	Factory Set	
87	ERV Unoccupied Fan	ON-OFF	ON-OFF	Factory Set	
88	Duct Static Shutdown Setpoint	Inches Water	0 to 5.0"	4.5"	

**NOTES:**

For On/Off functions, 1 is ON and 0 is OFF

Read only items are readings from sensors which only change as the measured condition changes.

## SERIES 40 SEQUENCE OF OPERATION

### OVERVIEW

The Series 40 unit control has comprehensive rule sets to respond to heat and cool calls, provide anti-shortcycle and other safeties, date / time clock, and other features making the programmable thermostat unnecessary. The control extends on the rules of the Synthesys digital control.

With an attached (optional) Room Sensor, the control provides calls for heating and cooling and occupied override. The control determines when to start morning warm-up, mechanical cooling, or heat based on parameter settings in the unit control, its internal time clock, Occupied and holiday schedules, the deviation from the setpoints, and the rate of temperature change.

A separate thermostat cannot determine if an output function is available. For example, if the belts on the supply fan were to break, the thermostat would still call for the fan to operate and, if space conditions require, call for heating or cooling. Logic in the control prevents undesired operation of heating and cooling stages, with interlocks and minimum run times. Moreover, the control can report faults on its digital display or on a network to a monitoring system.

Control logic is designed such that airflow must be proven before any heating or cooling stage can operate. Mechanical cooling is locked out below 40 °F outdoor ambient for all units without head pressure control. The control provides voltage to energize the contactors for the supply fan, cooling stages, heating stages, and options such as the economizer and power exhaust. The thermostat makes calls for cooling and heating; the control is responsible for executing the rules putting these calls into action and protecting the unit through appropriate safety devices. If the unit control senses low voltage, it will hold any call that energizes a contactor until the voltage is adequate. It will not alarm for low voltage, but will provide a flash code.

The control also energizes the supply fan and cooling stages based on external inputs from the thermostat:

- G - Supply Fan
- Y1-1st Stage Cooling
- Y2-2nd Stage Cooling
- Y3-3rd Stage Cooling
- Y4-4th Stage Cooling

Heating stages are controlled based on inputs:

- W1-1st Stage Heating
- W2-2nd Stage Heating
- W3-3rd Stage Heating

The economizer is enabled through settings in the control and operating conditions, or external BAS calls.

### RUN SEQUENCE

The unit operates in one of three modes: Occupied, Unoccupied, and Recovery (Warm-up / Cool-down). The control

allows none, one, or two separate occupied / unoccupied schedules for each day of the week, and twenty holidays. In addition to the programmed schedule, the space sensor allows a single key press to provide up to a 4-hour unoccupied override into the occupied mode.

**OCCUPIED MODE:** The supply fan operates continuously in the Occupied and Recovery modes. The thermostat cycles cooling / heating to maintain the space temperature to the Occupied setpoints. The unit control will enable optional economizer and power exhaust features.

**UNOCCUPIED MODE:** The supply fan operates only with cooling / heating calls. The economizer is disabled during the unoccupied mode except when free cooling may be used to condition the space. Cooling / heating stages are cycled to maintain the space temperature to the Unoccupied setpoints.

**RECOVERY MODE:** A special unoccupied mode that allows transition to occupied mode. The supply fan operates continuously and the economizer remains disabled. Instead of maintaining the unoccupied setpoints, the thermostat ramps the space temperature toward the occupied setpoints. The unit control has an option for the control to “learn” how long it takes to get the building to the desired temperature, and adjust its start time to minimize the recovery time. Refer to the Intelli-Start section.

### UNIT CONTROLS SEQUENCE

If the thermostat gives a call for G fan, W heating, or Y cooling, or the space sensor reading is not within the setpoint range; this is acted upon by unit control according to the sequence outlined below. A thermostat must not be connected anywhere but the appropriate labeled terminals. Direct control of compressors and heaters is not acceptable.

Abbreviations for various components correspond to the labels on the wiring diagram.

1. On a call for the supply fan, voltage at terminal G is acted on by the control. If the supply fan overload is not tripped, voltage goes out from the FAN terminal on the control to either contactor 5M (Supply Fan Motor Starter) or relay FR (permission-to-run for the Variable Frequency Drive). Power is applied to the airflow proving switch (APS). If the supply fan operates correctly (proper rotation), the pressure difference between the supply fan section and the heating section increases and APS closes to enable operation.

The air proving switch is monitored by the control 90 seconds after the fan is energized.

The control also monitors the supply fan overload. The overload circuit is wired directly to the control, not in series with the fan contactor. If the supply fan overload trips for longer than 5 seconds, the control will shut down the unit. If the trip clears within 15 minutes, the unit will log an error and resume operation. If the overload trips three times in two hours [or stays tripped longer than 15 minutes], the control will shut the unit down and report an alarm. In a VAV unit, the control will shut down the unit if the duct pressure shutdown setpoint is reached or exceeded.

2. Mechanical cooling stages have three monitoring circuits: low pressure, high pressure, and internal ["module"] compressor overheat. They are connected to the control through the LPSx, HPSx, and C10, C20, etc., terminals. These allow the control to track specific error alarms, and let the control energize the next available compressor.

**Table 6: Cooling Stage**

CALL	ECONOMIZER MODE	MECHANICAL COOLING MODE
COOL 1	Economizer (N/A)	Compressor 1
COOL 2	Compressor 1	Compressor 2
COOL 3	Compressor 2	Compressor 3
COOL4	Compressor 3	Compressor 4

**For units without optional head pressure control:** If the outside air temperature rises above 50 °F, the control enables all mechanical cooling stages. If the outside air temperature falls below 40 °F and the unit does not have head pressure control, mechanical cooling stages are locked out.

**For units with head pressure control:** The first and second mechanical cooling stages are enabled when the ambient temperature rises above 10 °F. When the ambient temperature rises above 50 °F, the third (on 30 and 40 ton) and fourth (40 ton only) stage mechanical cooling are enabled. If the outside air temperature falls below 40 °F, mechanical cooling stages 3 and 4 (40 ton only) are locked out. If the outside air temperature falls below 0 °F, all mechanical cooling stages are locked out. On units with optional heating, any call for heating engages the supply fan. Operation of heating is dependent upon the APS closure.

When all run rules are satisfied, cooling stages are available. A call for first stage cooling, Y1, initiates the control rules for cooling. When the control is satisfied [temperature, short cycling timing, safety circuits, etc.], it sends voltage out terminal C1 to contactor 1M for compressor 1. If compressor 1 is not available, the control will start compressor 2 via C2 / 2M.

In Occupied mode, the economizer is enabled [if installed and the parameter set in the control]; if free cooling is available, the economizer will energize in place of the first cooling stage.

A thermostat call for second stage cooling powers terminal Y2, third stage powers Y3 (30 and 40 ton) and fourth stage powers Y4 (40 ton only). These thermostat calls are entered into the control's logic, and available cooling stages brought on to meet the demand.

**NOTE:** The economizer may function when all mechanical cooling stages are locked out on low ambient.

3. When the control calls for Compressor 1 (25 ton), or Compressor 1 or 2 (30 and 40 ton), it will also call condenser fan stage 1 through terminal CF1, powering the coil of con-

tactor 6M (condenser fan 1). On 25 ton units, condenser fan 2 (contactor 7M) is brought on by PS5 if discharge pressure on compressor 1 exceeds 280 psi. Fan 2 drops out if discharge pressure drops below 180 psi; condenser fan 4 (contactor 8M) is brought on by PS6 monitoring discharge pressure on compressor 2.

4. A control call for Compressor 2 powers contactor 2M through terminal C2, and CF2 (fan 3) on 25 ton units. On 30 and 40 ton units, because fans 1 and 2 pull through coils for both circuit 1 and circuit 2, the coil of contactor 7M (condenser fan 2) is powered in turn through either of condenser fan cycling switches PS5 or PS6, which enables condenser fan 2 operation if the discharge pressure of Compressor 1 **or** Compressor 2 exceeds 280 psi.
5. 30 and 40 ton only: A call for Compressor 3 powers contactor 3M (contactor, compressor 3) from terminal C3. A call for Compressor 3 or 4 also powers terminal CF2, second stage condenser fans (contactor 8M, condenser fan 3, and also contactor 9M, condenser fan 4 - 40 ton only).
6. 40 Ton Only: A call for Compressor 4 powers the coil of contactor 4M from terminal C4.
7. Gas Heat Option, Stage 1: a W1 call locks out cooling and initiates the control logic for Heat 1. The supply fan is engaged, at full speed if VAV-equipped. Once APS (air proving switch) closes to acknowledge supply airflow, power is supplied from terminal H1, which engages Ignition Control 1 (IC1) at heat module terminal W/TH. 24V is supplied to IC1 at terminal R/24V, and to the overtemp limit switch LS1, which opens only with excessive heat exchanger temperature, on each gas heat module. That switch is monitored by connecting each limit switch to the LIM1, 2, or 3 terminal at the control board. IC1 closes contacts between terminals L1 and IND to engage Draft Motor 1. The 24V signal downstream from the overtemp limit switch goes through the vent motor air proving switch circuit to the PSW terminal on IC1.
- With LS1 and PS1 closed, IC1 will attempt ignition. IC1 provides direct spark ignition with flame verification, and controls the GV1 gas valve through manual reset switch RS1 (rollout switch). If RS1 has tripped, GV1 is locked out and IC1 will electronically lockout after three failed ignition attempts. The control monitors voltage to the gas valves through terminals GV1-3.
- When the W1 call is canceled, power is removed from IC1 terminal TH, which directs IC1 to close GV1. As long as APS continues to prove supply fan airflow, IC1 remains powered and keeps the L1 to IND contacts closed for 45 {60??} seconds to maintain the operation of Draft Motor 1 for a postpurge of the heat exchanger.
8. Gas Heat Option, Stages 2 and 3: the unit control responds to W2 and W3 similarly to W1, if the unit is equipped with second and third heat modules.
9. Electric Heat Option: the unit control allows staging electric heat. On units with the Electric Heat Option, a call for heat (W1) will initiate the main supply fan. When the control is

satisfied by the APS, it will complete the circuit to the first stage of electric heat by energizing terminal H1. If additional heat is required, H2 will energize the second stage of electric heat [if the unit is so equipped], and H3 the third stage [if the unit is so equipped].

## **WARNING**

Disconnect all power supplies before checking or servicing the electric heat section.

All electric heat modules have an auto-reset primary limit, monitored by the control, and non-restartable back-up limits. Dirty filters, broken belts, fan motor burn-out or running this unit below 6,000 CFM will cause the limit to trip on the auto-reset primary limit. In addition to the primary limit, back-up limits may trip under these conditions. The backup limits are one-trip devices and will have to be replaced should they trip.

When a call for heat has been satisfied, the highest stage running will be de-energized until all are de-energized.

10. Hot Water Heat Option: the unit will send a 2-10 VDC signal to drive a hot water valve.
11. Economizer Option: the control directly controls the position of the outside air / return air dampers through a 2-10 VDC signal from terminal ECO to ACT1 (economizer actuator). The economizer is enabled only in Occupied or Recovery mode, and after supply fan operation has been verified (APS closed). When the supply fan is powered and there is no Y1 call or if free cooling is unavailable, the control opens the economizer dampers to the minimum position setting.

The actuator maximum opening speed is 150 seconds to full open; the control moves the actuator at the rate of two seconds for each one % it is opening, so full open from closed would take 200 seconds. At entry to Occupied mode, the economizer is typically opening from 0 to a minimum setting of 20%, which would take about 40 seconds. In Unoccupied mode, the economizer will close to 0%.

With a Y1 call when the outside air is appropriate for free cooling (see below), free cooling is used for first stage cooling. The control modulates the economizer dampers to maintain a SAT setpoint plus or minus one degree.

The control uses one of three methods to determine when free cooling is available. The method used is determined by the unit options, which function as listed below.

**Dry Bulb:** the control relies on the RAT, OAT, and SAT readings, connected to those terminals on the control. Free cooling will be available until the outdoor temperature rises above the indicated temperature range. Free cooling is disabled when the outdoor temperature rises above the temperature range and cannot be enabled until the outdoor temperature falls below the indicated temperature range.

**Single Enthalpy:** The Outdoor Air Humidity Sensor is connected to terminal OAH. When the outdoor enthalpy is below the setpoint, free cooling is available.

**Dual Enthalpy (Comparative/Differential Enthalpy):** Both the Outdoor Air Humidity [OAH] and the Return Air Humidity [RAH] sensors are connected to the control. When the outdoor air enthalpy is less than the return air enthalpy, free cooling is available. The control will disable free cooling and force mechanical cooling when the outside air temperature exceeds setpoints.

12. Power Exhaust Option with Modulating Dampers: The power exhaust controls are enabled in Occupied or Recovery mode when the APS is satisfied. The building pressure is sampled by a tube provided and installed by the customer at a location in the building, connected to the high pressure port of the pressure transducer BPS. BPS provides a 0-5 VDC signal to the control, which compares the reading to the pressure setpoint to control the exhaust dampers. The exhaust damper vanes are modulated by ACT2, from a signal from terminal EXD+. The exhaust motor is energized by voltage at terminal EXH to contactor 10M when the dampers are driven above the ON setpoint for damper open %.

The exhaust motor is powered OFF when the vanes reach the OFF % point set in control parameters. When the power exhaust is disabled, ACT2's spring return closes the exhaust dampers and 10M opens to shut down the exhaust fans.

13. Power Exhaust Option with Variable Frequency Drive: The power exhaust controls are powered through EXH / 10M with a call for the supply fan. Once powered, the BPS sensor (Building Pressure sensor) sends a signal to terminal 53 of the VFD. The damper vanes are gravity-closed; motor speed is continuously variable. See separate document for details on power exhaust VFD operation.
14. Non-modulating Power Exhaust Option: The power exhaust motor is energized by EXH / 10M based on the position of the Economizer damper settings in the control parameters. Minimum run time is 10 seconds; minimum off time is 60 seconds. The outlet pressure of the power exhaust fan forces the barometric relief dampers open; gravity closes the dampers when the exhaust fan is off.

## VARIABLE AIR VOLUME UNIT (VFD & IGV)

### OVERVIEW

The VAV units operate in one of three modes: Occupied, Unoccupied, and Recovery. The unit operational mode is determined by the status of the internal clock and the internal schedules.

### OCCUPIED / UNOCCUPIED / MORNING WARM-UP

#### OCCUPIED

In Occupied mode, all installed options enabled by the parameter settings are available. The supply fan is operated [controlled to the duct pressure setpoint if a VAV], optional unit

heating is available at full capacity, the optional power exhaust system is enabled, the economizer outside air dampers go to their minimum position or open for free cooling. This operation continues until the unit enters Unoccupied mode. When the control sees an Occupied override button push from the thermostat or space sensor, it will go to Occupied mode for the length of time set in the parameters, up to four hours. If the unit is in Space Sensor operation, the fan will operate at full speed [controlled to the duct pressure setpoint if a VAV].

A VAV standalone unit will run MWUP the first hour of the OCC override signal, then go to Occupied. The supply fan will run continuously.

## UNOCCUPIED

In Unoccupied mode, the economizer goes to full closed; the supply fan will only operate if there is a call for heating or cooling [controlled to the duct pressure setpoint if a VAV]. If heating is required, all installed stages will be energized.

### CAUTION

The bypass VFD is a standard Variable Frequency Drive packaged with a further set of contactors. When bypass mode is activated, contactors route power around the VFD, connecting the indoor fan motor direct to supply voltage. At this point the motor will go to full RPM regardless of the duct pressure signal, because the VFD is out of the loop, and there is a potential for over pressuring the ducts.

The air balancer must set maximum duct static / CFM to stay within a static pressure that the ductwork of that installation can tolerate when the motor is at full RPM, considering that the VAV boxes, if they are part of the system, may not be full open.

If the duct system includes VAV boxes, they must be driven open in Bypass mode in the same manner as going to heat mode. The drive indicates being in "bypass" mode with normally open contacts wired to terminal block 1, position 5 and 6 across Danfoss relay M3 [refer to drawings supplied by Danfoss, packed with the unit].

Voltage sufficient to signal the boxes to open must be wired through this contact. This is a field-install connection.

## MORNING WARM-UP [MWUP]

The unit enters a morning warm-up mode going in to the first Occupied period of the control's internal daily schedule. In this mode, the supply fan is operated at full volume, optional unit heating is engaged at full capacity if needed, the optional power exhaust system is enabled, the economizer outside air dampers close (return air dampers open), cooling is disabled, and voltage is provided at H1 to signal the remote VAV boxes to

open. This operation continues until the return air temperature exceeds the adjustable setpoint of the Morning Warm-up bulb thermostat (MWUP).

The parameter for MWUP must be turned on. Without Intelli-Start, MWUP will start one hour ahead of Occupied. Cooling will not start until the Occupied mode starts. In MWUP, the control will operate the fan and energize heat after monitoring RAT five minutes after going into MWUP, or if RAT goes two degrees below the MWUP setpoint.

## UNIT CONTROLS

1. The control reviews parameters, the unit clock, and occupied / Holiday schedules to select the appropriate mode. In Occupied mode, the unit will look at inputs enabled by parameter settings. It will default to secondary inputs if necessary.

When the unit is running in Occupied mode, the duct pressure controller, if that option is installed, is activated; the optional power exhaust system is activated, power is applied to the airflow proving switch (APS), and to the supply fan motor contactor (5M) to engage the supply fan. If the supply fan operates correctly (proper rotation) the pressure difference between the supply fan section and the heating section increases and APS closes to enable operation. The control waits 75 [90??] seconds for the fan to reach equilibrium, then looks at the APS.

For units without optional head pressure control: If the outside air temperature rises above 50 °F the control enables all mechanical cooling stages. If the outside air temperature falls below 40 °F, then all mechanical cooling stages are locked out.

For units with head pressure control: Enable third and fourth (40 Ton only) stage mechanical cooling when the ambient temperature rises above 50 °F. If the outside air temperature falls below 40 °F, mechanical cooling stages 3 and 4 (40 Ton only) are locked out. Enable first and second stage mechanical cooling when the ambient temperature rises above 10 °F. If the outside air temperature falls below 0 °F, all mechanical cooling stages are locked out.

2. While the return air temperature remains below the setpoint of MWUP (Morning Warm-up), engage the unit heat (optional) at full capacity.

For Inlet Guide Vane VAV: terminal VFD provides a 10VDC signal for the actuator, thus forcing the inlet guide vane dampers to fully open during the warm-up cycle. Terminal H1, heat stage 1, is used to signal the remote VAV boxes to open. In this warm-up mode, VAV and the economizer (optional) are disabled, so cooling is disabled and the optional economizer outside air dampers are closed.

3. When the return air temperature climbs above the MWUP setpoint, heating is disabled, VAV and the economizer are enabled.
4. A call for first stage cooling initiates the cooling sequence. The optional economizer is enabled, and drives the damper

to the minimum open position. If free cooling is available, dampers open to satisfy setpoints. If there is no economizer, the control powers terminal C1 to energize compressor 1.

The control provides a minimum of 30 seconds between each cooling stage call [see Lead-Lag], a 4 minute minimum ON time for each cooling stage and a 5 minute minimum OFF time for each cooling stage.

5. A call for Compressor 1 powers the high pressure safety switch (HPS1), the low pressure switch (LPS1), the coil of contactor 6M (condenser fan 1), and the coil of contactor 7M (contactor, condenser fan 2) through condenser fan cycling switch PS5 (PS5 disables condenser fan 2 operation based upon the discharge pressure of the Compressor 1). If the system pressures are within HPS1 (high refrigerant pressure) and LPS1 (low refrigerant pressure) switch settings and the solid state compressor motor protector (Compressor Module No. 1) is not tripped, contactor 1M is engaged to start scroll Compressor 1.
6. A call for Compressor 2 powers contactor 2M (contactor, compressor 2) if HPS2, LPS2 (high and low refrigerant pressure) and Compressor Module 2 (compressor motor protector) contacts are closed.
7. 30 and 40 ton only: A call for Compressor 3 powers the coils of contactors 8M (contactor, condenser fan 3) and 9M (contactor, condenser fan 4 - 40 ton only). If HPS3, LPS3 (high and low refrigerant pressure) and Compressor Module 3 contacts are closed, power is applied to the coil of Contactor 3M, which starts compressor 3.
8. 40 Ton Only: A call for Compressor 4 powers the coils of contactor 4M if HPS4, LPS4 (high and low refrigerant pressure) and Compressor Module 4 contacts are closed.
9. When the internal time clock matches the setting in the holiday and daily schedules, the unit enters Unoccupied mode. The control disables the supply fan, the optional power exhaust, cooling, heating, and the economizer. The optional outside air dampers are closed with the optional inlet guide vanes.
10. When the space temperature falls below the heating setpoint, the control powers contactor 5M from terminal FAN to engage the supply fan motor. If the supply fan operates correctly (proper rotation) the pressure difference between the heating section and the supply fan section increases and APS closes to enable heating operation. If heat safeties are satisfied, the VAV speed signal (VFD or Inlet Guide Vanes) goes to maximum flow [the customer-installed connection will drive the VAV boxes to full open]. The control engages unit heat (optional) at full capacity. Until heat is energized, duct pressure control is activated. The optional power exhaust system is activated.

In heat mode, cooling is disabled and the optional economizer outside air dampers are closed. This operation is maintained until the space temperature rises above the heating setpoint or Occupied mode is engaged.

11. **Gas Heat Option, Stage 1:** A call for heat engages Ignition Control 1 (IC1-terminal TH) from control terminal H1. Once APS (supply air proving switch) closes to acknowledge supply airflow and the LIM1-3 safeties are satisfied, IC1 is powered. IC1 closes contacts between terminals L1 and IND to engage Draft Motor 1. The IC1 monitors PSW (draft fan air proving switch) and LS1 (heat limit switch, which opens only with excessive heat exchanger temperature). When the safeties are satisfied, IC1 will attempt ignition. IC1 provides direct spark ignition with flame verification and controls the GV1 gas valve through manual reset switch RS1 (rollout switch). If RS1 has tripped, GV1 is locked out and IC1 will electronically lockout after 3 failed ignition attempts. The control also monitors the voltage going to the gas valve at terminals GV1-3.

When the W1 call is canceled, power is removed from IC1 terminal TH, which directs IC1 to close GV1. As long as APS continues to prove supply fan airflow, IC1 remains powered and keeps the L1 to IND contacts closed for 45 seconds to maintain the operation of Draft Motor 1 for a post-purge of the heat exchanger.

12. **Gas Heat Option, Stages 2 and 3:** These follow the same rules as Stage 1. Separate terminals and safety monitor circuits are wired to each installed heat stage. For gas heat, there is a separate overtemperature limit switch for each heat module.
13. **Electric Heat Option:** A call for heat stages electric heat on. Electric heat is available as 40kW [one stage], 80kW [two stages], or 108kW [three stages]. There is one over-heat limit for electric heat, regardless of the number of stages - contrasted with gas heat, which has individual over-heat limits on each module.

On units with the Electric Heat Option, a call for heat (W1) will initiate the main blower. The blower will produce static in the supply and the Air Proving Switch (APS) contacts will close. The control recognizes closure of the APS and energizes the H1 terminal to complete the circuit to the first stage of electric heat.

In Occupied mode, if additional heat is required, the W2 signal will energize the second stage of electric heat through terminal H2; W3 / H3 function similarly. When the W2 call for heat has been satisfied, W2 will be de-energized and will in turn de-energize H2 second stage heat. As the call heat (W1) has been satisfied, W1 will be de-energized. If the unit is in Unoccupied mode, the fan will shut off and the APS will open. For units in space sensor control, the control will stage on heat as required to maintain space sensor temp, or SAT temp if the space sensor signal is lost.

All electric heat modules have an auto-reset primary limit and non-restartable back-up limits. Dirty filters, broken belts, fan motor burn-out or running this unit below 6,000 CFM will cause the limit to trip on the auto-reset primary limit. In addition to the primary limit, back-up limits may trip under these conditions. The back-up limits are one-trip devices and will have to be replaced should they trip.

14. When the space temperature rises above the Unoccupied cooling setpoint, the control enables optional duct pressure control and optional power exhaust system; power is applied to the airflow proving switch (APS) and to the coil of starter 5M to engage the supply fan motor. If the supply fan operates correctly (proper rotation) the pressure difference between the heating section and the supply fan section increases and APS closes to allow mechanical cooling operation. The unit operates as though it were in the Occupied mode (see above) until the space temperature falls below the cooling setpoint or Occupied mode is engaged.
15. **Duct Pressure Control - Inlet Guide Vane Option:** The duct pressure controls are powered with a call for the supply fan. Once powered, the pressure transducer DPS provides a voltage signal input to the control. The control calculates a 2-10VDC signal to the inlet guide vane actuator.
16. **Duct Pressure Control - VFD (Variable Frequency Drive) Option:** The duct pressure controls are powered with a call for the supply fan. Once powered, the VFD responds to a VDC control signal from the DPS (Duct Pressure transducer). In the heating mode the VDC, DPS pressure signal forces the fan to full volume. VAV boxes should be tied to the H1 terminal to signal the boxes to full open.
17. **Electronic Economizer Option:** The control directly controls the position of the outside air / return air dampers through a 2-10 VDC signal to ACT1 (economizer actuator). The economizer is powered only after supply fan operation has been verified (APS closed) and the unit is in Occupied or Recovery mode. When the control is not powered or is in Unoccupied mode, the outside air dampers spring return closed. When in Occupied or Recovery mode and there is no Y1 call or if free cooling is unavailable, the control opens the economizer dampers to the minimum position setting made in the parameters.

With a Y1 call where the outside air is appropriate for free cooling (see below), the control modulates the vanes for free cooling in place of first stage cooling. (Please see the compressor staging chart above.) The control modulates the economizer dampers to maintain a Mixed Air Temperature (Return Air / Outside Air Mixture, sensed between the filters and the DX coil) between 50 °F and 55 °F (adjustable between 40 °F and 65 °F).

The control uses one of three methods to determine when free cooling is available. The method used is determined by the option selection.

**Dry Bulb:** The control refers to input from the OAT, and will allow free cooling when the outdoor temperature falls below the Economizer First Stage temperature setpoint. Free cooling will be available until the outdoor temperature rises above the temperature setpoint.

**Single Enthalpy:** the control will consider, along with outside temperature, outside air humidity [OAH sensor; parameter must be set to ON] in enabling free cooling. The

outside air enthalpy setpoint parameter [BTU per pound] must also be set.

**Dual Enthalpy (Comparative/Differential Enthalpy):**

Both the Outdoor Air Enthalpy and the Return Air Enthalpy [RAH sensor, option parameter must be set to ON] are connected to the control. The setpoint when the outdoor air enthalpy is less than the return air enthalpy, free cooling is available. The rules in the control will lock out free cooling and force mechanical cooling when the outside air temperature exceeds setpoints.

18. **Power Exhaust Option with Modulating Dampers:** The power exhaust controls are enabled in Occupied mode. The building pressure sensor [BSP] provides a signal to the control. The exhaust dampers are modulated by a 2-10VDC signal from the control, proportional to the pressure sensed, to the damper actuator. When the actuator opens the damper more than the parameter "Exhaust Damper Position for Exhaust Fan to Turn ON" setting, the control powers the 10M starter to engage the power exhaust fan motor. When the dampers reach the "Exhaust Damper Position for Exhaust Fan to Turn OFF" setting, the control turns the motor off. When the power exhaust is disabled, the control closes the exhaust dampers.
19. **Non-Modulating Power Exhaust Option:** The power exhaust controls are enabled by the control. The control powers the exhaust fan motor by monitoring the position of the economizer damper vanes ["Economizer Damper Setting for Exhaust Fan to Turn ON [OFF]"]. The outlet pressure of the power exhaust fan forces the barometric relief dampers open. Exhaust Fan operation is continued until the economizer reaches the % set in the parameter Gravity closes the barometric relief dampers when the exhaust fans are off.
20. **Power Exhaust Option with Variable Frequency Drive (VFD):** The power exhaust controls are enabled through the control. The variable frequency drive is controlled by a signal from the control, based on the Building Pressure sensor (BPS), located in the control box, which translates the building pressure signal to a VDC signal. Fine tuning is accomplished by setting parameters in the VFD [ref: separate instruction].

**NOTE:** Modulated exhaust: Pressure-tap tubing must be run from an appropriate location in the building to the "high" port on the BPS transducer. Dampers on the VFD power exhaust are gravity-closed and are not modulated. The BPS signal is proportional with the difference between outside ambient pressure and building pressure. The VFD is set for a minimum speed of 33% and a maximum of 100%. The VFD parameters are factory set, specific for each control system, and are detailed on a sticker by the drive. The drive manual is shipped with the unit.

**NOTE:** For smoke purge, etc., special connections: for standard controls, consult a controls specialist familiar with your local codes.



All power exhaust options require that the customer provide tubing connections to the transducer from a representative location in the building; modulating-vane and VFD exhausts will open full / power on in Purge mode

## HEAD PRESSURE CONTROL

### DESCRIPTION

The head pressure control option controls the speed of condenser fan 1 for low ambient mechanical cooling operation of systems 1 and 2. This option functions independently of the unit control.

The option includes two pressure transducers and a variable frequency drive. The pressure transducers are connected to the discharge line of system 1 and 2. The VFD modulates to the higher signal; if either system 1 or 2 exceeds 280 psi, a secondary mechanical switch close to turn on fan 2. Typically the modulated fan will slow down; if both systems drop below 180 psi, fan 2 drops out.

System 3 on a 30 ton and system 3 and 4 on a 40 ton are locked out below 45 °F ambient.

**NOTE:** Altering the factory settings could result in poor control or operation of the system.

No special motor is required on three-phase systems; single phase systems will use three phase motors on fan 1. The variable Frequency Drive is pre programmed at the factory.

### SEQUENCE OF OPERATION - FOR HEAD PRESSURE CONTROL

A call for the first stage cooling powers the 6M contactor energizing the variable frequency drive. The drive will ramp to the pre programmed minimum speed of 20 Hertz immediately upon start up. As the discharge pressure on system 1 or 2 compressor rises, the transducer output signal to the variable frequency drive rises. The drive will increase the speed of condenser 1 fan, maintaining a setpoint of 240 PSI.

The scroll compressor produces a rapid rise in discharge pressure upon start up. This usually will result in full speed operation of condenser fan 1. After the discharge pressure has settled out, the speed of condenser 1 may decrease especially during times when the ambient temperature is below 80 °F. After the 1 system has stabilized and compressor 2 is energized, the speed of condenser Fan 1 will increase to compensate for the discharge pressure rise. Typically, since fan 2 will run at full speed, fan 1 will slow down when fan 2 energizes.

As the ambient temperature drips below 40 °F the 1 condenser fan will slow to the minimum speed. The circuit 2 condenser fan will disengage when the discharge pressure drops below 180 PSIG as

the ambient temperature falls. The discharge pressure of system 1 and/or 2 will increase when condenser fan 2 stops, consequently causing an increase in the speed of condenser fan 1.

The unit control includes a terminal SD for the user to wire a signal to shut down, and a Purge terminal to signal the unit to shut off heat or mechanical cooling, open the economizer and exhaust dampers, and run the exhaust fan [depending on which options are installed on the unit].

### INTELLI-START

If Intelli-Start is enabled the control will use that calculation to determine when to start Morning Warm-Up. If the Intelli-Start option is not enabled, the control will start Morning Warm-Up one hour before Occupancy.

When Intelli-Start is enabled, the control will attempt to recover the building to the Occupied Setpoint by the time the Occupied period begins. On the first day when the control has nothing stored for recovery, it will go "Occupied" two hours before the Occupied period. The control will store the beginning demand and track the time it takes to reach the Occupied Setpoint. When the Occupied setpoint is reached, the control will store how long it took, and use that warm-up ability to calculate the period needed the next time it runs. The control will store the recovery value separately for Heating and Cooling. Unoccupied Recovery will only run on the first Occupied period of the day. It will always be operating on the previous day's performance. The Economizer will be used if free cooling is available.

The control will accommodate inputs for water coil freeze stat, SA sensor, ODA sensor, Space sensor, and Room sensor, Building pressure sensor, Duct pressure sensor, Demand ventilation, RA humidity, OD humidity, RS485 communications.

### LEAD LAG

When this option is set ON, the unit will equalize run time on compressors [except for compressor 1 if the head pressure control option or hot gas bypass is installed].

### DEVICES AND RULES

This chapter describes the many control modes of operation for the unit control. Because of the narrative and detailed descriptions contained in this section, you should only scan this chapter and become familiar with the primary topics. Then, use this chapter as a reference whenever a more detailed understanding of a particular mode is needed.

You should keep in mind that, especially with digital controls, interlocking between control modes is common and easily achieved. Also, by the very nature of digital control programming, many simultaneous rules can be implemented because they generally require only software programming and very little peripheral hardware. This reduces the costs associated with manufacturing and servicing equipment with this level of interacting features - but you can't see the status of interlocked rules as you can with discreet relays.

Several control modes will override other modes of operation.

For example, The Demand Ventilation (or, Indoor Air Quality) control may override Comfort Ventilation / Economizer control and drive the OA dampers above the established minimum position. The Excessive SAT control will override all temperature control modes, Economizer mode, and compressor operation as well. If you suspect that a problem exists with the economizer, or the compressors are locked out when no alarms are set, verify that one of the control modes is not overriding the normal mode of operation or the operation you might expect to see. Another important example is the Air Proving Switch interlocking mode. If the Air Proving Switch alarms on a VAV unit, the unit will refer to the duct pressure sensor; if duct pressure is present, the control will assume the fan is working even though the APS is not.

If the fan status [APS] fails, and the duct pressure switch of a VAV unit sees no duct pressure, all controlling algorithms and operations, and outputs (except hydronic heat) will cease and the control will shut down all outputs.

### AIR PROVING SWITCH

When the control starts the supply fan, it waits 90 seconds to check for closure of the Air Proving Switch (APS). If the APS does not close, the control will turn off all outputs except Fan and the VFD speed signal, flag an alarm, and flash an alarm on the display. If it is a VAV unit, the control will look to the duct pressure signal; if it is above .05", the control will flag a bad APS and continue operation.

It will retry the Fan output every 30 minutes for three retries. If after three retries it still cannot qualify the Fan, it will Alarm and lock all heating and cooling operation out. If the switch closes after an alarm has been flagged, the control will resume normal operation and clear the active alarm.

After the control has turned off the fan, it will wait 90 seconds and verify that the switch opens. If the switch does not open after 90 seconds, the control will flag a failed switch and flash the alarm. On the next startup, the control will stage up equipment normally.

This switch-closed failure mode of the Air Proving Switch can only be detected with the Supply Fan off. It is important to detect because it effectively disables the fan failure alarm checking while fan is running, described in the paragraphs above. Those checks would always pass as the switch would remain closed. In networked applications, the error flag is readable by the network. The alarm will automatically reset after the problem that caused it has been corrected.

When the control is running the fan and the APS has already been proven, and then it opens, the control will wait 2 seconds before shutting down heating, cooling, and locking out. It will alarm and retry as if it happened during start-up.

### FAN DELAYS

There are separate Fan ON and OFF delay periods for heating and cooling, to reduce the momentary change in SAT.

### COMFORT VENTILATION MODE

Comfort Ventilation is a control mode that uses the economizer to modulate SAT. Where possible, the economizer will modulate the outside / return air mix to keep SAT within the upper and lower Comfort Ventilation setpoints. The control will modulate the economizer, and energize cooling or heating if necessary, to keep SAT within the Comfort Ventilation setpoints, even though space temperature may be satisfied.

For example, minimum economizer position can take SAT out of the Comfort Ventilation range, requiring heat or cooling that the thermostat isn't calling for. The result of comfort ventilation control is less variation of SAT, and fewer on-off cycles of mechanical cooling or heating. If turning off a cooling stage raises SAT above the upper setpoint, but leaving it running will take SAT below the lower setpoint - then the compressor is left on, and warmer outside air is brought in to raise SAT to the lower setpoint to keep a compressor from cycling off. Similarly, if leaving a heat stage on will raise SAT above the Upper setpoint, the control will leave heat on and modulate cooler outside air into the mix.

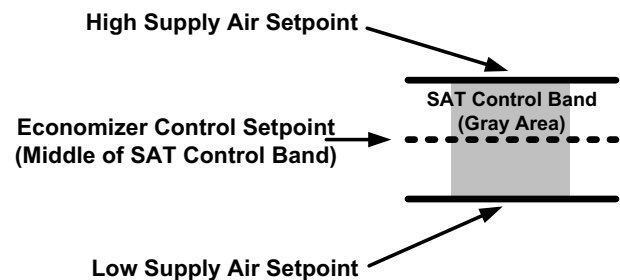

**Figure 6: VFD Control Wiring**

The Comfort Ventilation temperature-band minimum width is five degrees. Comfort Ventilation high and low setpoints will be within the Cooling Upper and Heating Lower setpoints.

Without using the Comfort Ventilation mode where available, when the space temperature control loop is satisfied (zero demand), all cooling and/or heating stages would be turned off and the SAT would be allowed to float until the space temperature control loop again generates a call for cooling or heating. The supply fan may be kept on during the "satisfied" periods, or may be turned off, depending on thermostat settings, or "Fan ON mode with the Sensor" option setting.

If Comfort Ventilation is selected, it will take priority over supply fan control and keep it running during the "satisfied" periods, when there is no call for heating or cooling. The Comfort Ventilation mode is used to optionally replace the uncontrolled, floating SAT situation during the "satisfied" periods with a "loose" SAT control in a fairly wide temperature band (between specified Comfort Ventilation Upper Setpoint and Comfort Ventilation Lower Setpoint). This may require some additional energy, but improves space comfort (e.g. instead of bringing a very hot and humid ventilation / outdoor air into space during the "satisfied" periods, the ventilation air temperature is "trimmed" to be within the specified SAT control band).

Comfort Ventilation mode terminates when there is a call for heating or cooling from the space temperature control.

- Comfort Ventilation can be used only on units equipped with an Economizer.
- Comfort Ventilation only operates in an Occupied mode.
- “Comfort Ventilation Mode” must be set to ON (default setting is OFF).

The modulating range of the economizer dampers are limited by a specified Economizer Minimum Position and by a specified Comfort Ventilation Maximum Economizer Setpoints.

The Economizer capability to control SAT may be further limited in case the Demand Ventilation Operation is enabled and overrides the economizer to a more-open position in order to satisfy space IAQ requirements. The values of “Comfort Ventilation Upper Setpoint” and “Comfort Ventilation Lower Setpoint” would typically be set such that they are centered around an expected return air temperature. The band between the two setpoints should be set wide enough so that SAT changes due to staging / destaging compressors, or heating stages, can be compensated for by the economizer control such that staging / destaging is minimized. Also, a wider band minimizes use of additional energy during unit’s “satisfied” periods.

### ECONOMIZER CONTROL DURING COMFORT VENTILATION

Economizer control uses a Proportional-Integral control algorithm that maintains SAT within the specified SAT band by modulating the economizer dampers. The PI algorithm setpoint is calculated as a midpoint between the programmed “Comfort Ventilation Upper Setpoint” and “Comfort Ventilation Lower Setpoint”. As the controller uses outside air to maintain the SAT at the setpoint, it must be capable of self-configuration for Direct, or Reverse action, depending on the relationship of the OAT to the specified SAT control band:

- If the OAT is below the specified SAT band low setpoint (“Comfort Ventilation Lower Setpoint”), the action is Direct Acting. In this case, the economizer control can lower the SAT temperature just by opening the economizer damper and using more outdoor air. However, if the economizer algorithm can not prevent the SAT from dropping below the bottom control band limit by closing the economizer damper to its programmed minimum position, one or more heating stages may need to be turned on. Similarly, if the economizer algorithm can not prevent the SAT from increasing above the top control band limit, one or more compressors may need to be turned on.
- If the OAT is above the specified SAT band high setpoint (“Comfort Ventilation Upper Setpoint”), the action is Reverse Acting. In this case, the economizer control can increase the SAT temperature just by opening the economizer damper and using more outdoor air. However, if the economizer algorithm can not prevent the SAT from increasing above the top control band limit by closing the economizer damper to its programmed minimum position, one or more compressors may need to be turned on. Similarly, if the economizer algorithm can not prevent the SAT

from dropping below the bottom control band limit by opening the economizer damper, one or more heating stages may need to be turned on.

- If the OAT is within the SAT control band, i.e. between the programmed “Comfort Ventilation Upper Setpoint” and “Comfort Ventilation Lower Setpoint”, the economizer damper is driven to the fully open position. In this case, no other control action needs to be taken to maintain the SAT within the specified control band.

### STAGING CONTROL DURING COMFORT VENTILATION

The economizer control alone may not be able to maintain the SAT within the specified control band. A separate staging control algorithm supplements the economizer control and will stage heating, or mechanical cooling as necessary. If the SAT increases above the “Comfort Ventilation Upper Setpoint” for more than 5 minutes, the control will destage a heating stage (if any heating stages running), or add a compressor. The control will repeat this process every 5 minutes until the SAT gets back to within the control band.

If the SAT drops below the “Comfort Ventilation Low Supply Air Setpoint” for more than 5 minutes, the control will destage a compressor (if any compressors running), or add a heating stage. The control will repeat this every 5 minutes until the SAT gets back to within the control band. As the heating stages, or compressors are staged up, or destaged, the economizer controls continues using the economizer damper to “trim” the effect of the staging and to maintain the SAT as near the middle of the SAT control band as possible.

If the unit is using hydronic heat, the control modulates the water valve to maintain SAT at the programmed “Comfort Ventilation Low Supply Air Setpoint”. At this setpoint, the hydronic heat control does not conflict with the economizer control, and will prevent SAT from dropping outside of the specified control band when the economizer can no longer maintain the SAT at its middle-of-the-band setpoint.

### HYDRONIC HEAT

The Hydronic Heat option requires relocating the SAT sensor downstream of the heating coil.

During hydronic heating, the SAT control to the selected “Hydronic Heat First Stage SAT setpoint”, or “Hydronic Heat Second Stage SAT Setpoint” is performed using a Proportional / Integral control algorithm. The control algorithm includes special provisions (sometimes referred to as a “bumpless transfer” feature) that allow it to resume control of SAT as fast as possible when it is re-activated during the ON / OFF cycling of the unit (cycling between a satisfied and a heating state under control of a zone thermostat, or zone sensor). In its OFF-state, the control algorithm continues monitoring the SAT and performs calculations necessary to set its output, that controls the hot water valve, to have the same value on starting the ON-cycle as it had when it went into the OFF-cycle (in spite of some decrease in the SAT during the OFF-cycle).

The “bumpless transfer” feature of the hydronic heat control algorithm essentially acts similar to a “memory” that holds the

algorithm output during the OFF-cycles. This “memory” is reset only on unit shutdown. The effect of this “memory” can be observed on the action of the hot water valve. After unit startup (during the first ON-cycle of the hydronic heat), there is no “memorized” output value and the valve moves relatively slowly into a control position required to maintain the SAT setpoint. On subsequent ON cycles, the valve moves into a control position much faster as dictated by the output value stored in control algorithm “memory”.

### COOLING LOCKOUT ON OAT

This is the Outside Air Temperature Setpoint that the control uses to lock out mechanical cooling when the OAT is below this setpoint. There is a one-degree hysteresis on each side of the setpoint. Adjustable from 0 °F to 100 °F, the default is 45 °F.

The change to 0 °F applies only to compressors # 1 and # 2 when head pressure control is installed. Cooling Lockout on OAT may occur while the control is in an Economizer mode and there is a demand for compressors.

### WATER COIL FREEZE STAT (FSI)

This option is used only on rooftop units with hydronic heat (Hydronic heat option is turned ON). When the FSI terminal sees 24 VAC, the control will open the Hot Water valve to 100%. The control will continue to drive the valve to 100% until five minutes after the switch has closed. If the control is operating the Fan, it will close the Economizer fully until the freeze condition is over. If the fan is off and the RAT drops below 40 °F, the Hot Water Valve will turn on 100%. This control sequence takes place regardless of the supply fan status (it is expected to be used/ needed mostly in situations when the supply fan is not running). A Hot Water Coil Freeze Alarm is generated. The alarm is written to the Error History Buffer. In networked applications, the alarm flag is readable by the network.

After the valve override sequence described above is completed, the valve will revert to normal operation and the alarm is automatically reset. The same sequence is repeated every time the Hot Water Coil Freeze Switch opens (infinite retries).

### CV OPERATION

The paragraphs below identify control modes of CV operation and provide an overview of control methods in all modes. The modes include Occupied and Unoccupied Heating and Cooling, and differ depending on the method used to control zone temperature (thermostat, or a space sensor). The heating vs. cooling modes are entered under control of the thermostat, or, in case of space sensor, control algorithm detecting zone cooling or heating demand. The "occupied" vs. "unoccupied" modes are controlled by an internal time clock. If a thermostat is connected in addition to the space sensor, it takes priority over the space sensor.

### THERMOSTAT OPERATION FOR COOLING WITH Y1, Y2, Y3 AND Y4 INPUTS

When connected to a thermostat, the unit control will apply internal rules to specific G, Y1, W1, etc., requests for fan, cooling, or heating; other inputs such as SAT, economizer

availability, etc., will be considered before acting on the thermostat request.

When stage outputs are de-energized, and when the four time delay settings in "Fan ON Delay for Heat, OFF for heat, ON for Cooling, and OFF for Cooling" are made, the Fan output will continue for the set time even if the G input becomes inactive along with Y1 and Y2. If G does not terminate, the controller will continue to operate the Fan.

A Minimum Run Time of up to ten minutes applies to all compressors. There is a built-in five-minute ASCD cycle whenever a compressor is destaged. The minimum run time is necessary to ensure that the oil in the refrigerant circuit circulates back to the compressor. A minimum ASCD delay of five minutes (nominal) applies any time compressor operation is started other than destaging. The actual minimum off times for individual compressors differ by 10 seconds in order to prevent compressors from turning on simultaneously during certain control mode transfers:

### GROUPING COMPRESSORS INTO STAGES

In space sensor operation in CV mode: On two compressor units, compressor one is first stage and compressor two is second stage. On three compressor units, compressors one and two are first stage and compressor three is second stage. On four compressor units, compressors one and two are first stage and compressors three and four are second stage. There is a five-minute delay (cooling interstage delay) between stage-one and stage-two operation

Otherwise the system treats each compressor as a stage.

**Table 7: Compressor Minimum Off Times**

COMPRESSOR	MIN. OFF TIME
#1	4 min. 40 sec
#2	4 min. 50 sec
#3	5 min. 00 sec
#4	5 min. 10 sec

### ECONOMIZER MODE

In CV cooling with a thermostat and when free cooling is available ("economizer suitable"), the SAT controlled by the economizer control algorithm (see section Economizer Operation later in this manual) and the thermostat determines (by 1st and 2nd stage calls) the active economizer SAT setpoint. When the thermostat is satisfied (Y1=OFF, Y2=OFF), then the unit either shuts down (in case G=OFF) after the specified supply fan overrun time, or only the supply fan continues to operate (in case G=ON). The operation of the thermostat's G signal is determined by the thermostat's fan mode switch

**NOTE:** During Economizer operation using "Economizer First Stage Setpoint" for SAT control, one or more compressors may be running in addition to economizer damper partially, or fully open to provide free cooling. The number of compressors running will mainly depend on outdoor air temperature. Therefore, when the thermostat is

satisfied and shuts down the cooling, it may be turning off more than one compressor (after compressor minimum run time expires). This is acceptable and is not expected to occur frequently. See the section on Comfort Ventilation. If the outdoor air condition is such that more than one compressor is needed in addition to free cooling, the Economizer mode is likely to terminate and the unit will switch over to mechanical cooling only.

## OPERATION FOR HEATING WITH W1, W2, AND W3 INPUTS

W1, W2, and W3 inputs are available on the unit control board.

### SUPPLY FAN OFF DELAY

When the Wx thermostat signal is de-energized, the fan output will continue until the SAT drops below 100 °F with a 5 °F differential to prevent fan cycling, i.e. the fan will go off when the SAT drops below 95 °F. This control sequence will be in effect even if G becomes inactive along with Wx. If G does not terminate, the Fan will continue to operate. The parameter "Turn Off Continuous Fan Operation When Starting Heat" can be set to the customer's preference.

### HEAT STAGE DELAYS

Three minute Minimum Run Time and two minutes minimum off time applies to all heat stages.

### THERMOSTAT OPERATION WITH HYDRONIC HEAT

The zone thermostat makes a selection between satisfied state (W1, W2, and W3 off), heating using a programmed "Hydronic Heat 1st Stage SAT Setpoint" (W1 is on, W2 is off), or heating using a programmed "Hydronic Heat 2nd Stage SAT Setpoint" (both W1 and W2 are on). During heating, the SAT control to the selected SAT setpoint is performed using a PI algorithm.

### SENSOR OPERATION

Typically, only a thermostat, or only a space sensor would be installed. However, there are cases where both could exist. One such case is servicing or troubleshooting the unit. A service person will typically hardwire the thermostat inputs to check the equipment operation even if the unit is using a space sensor. The thermostat input will have priority over the Space Sensor. A unit using a space sensor will switch to a thermostat control strategy automatically if a thermostat input is detected and switch back if the thermostat is no longer detected.

### TYPES OF SPACE SENSORS

**No Sensor** - The system will internally detect the presence of space sensors.

**Sensor with Unoccupied Override Button** - This Sensor has a Thermistor and an Override button that shorts the Sensor when pushed. If the Override button is pushed the unit will go into the Unoccupied Override mode for the Unoccupied Override Time (note that the control must not recognize the short as a sensor failure). Once the Unoccupied Override mode

is initiated, it will continue until the programmed Unoccupied Override Time Limit is reached.

**Sensor with Space Setpoint Adjust** - This Sensor has a slider potentiometer on it that represents (as a default) +/- 3 °F adjustment to the Space Setpoint. The Space Setpoint Offset option. If the unit appears to be controlling at a higher or lower temperature than the setpoint, check the Space Setpoint Adjust slider.

### SUPPLY FAN CONTROL WHEN USING A ZONE SENSOR

In the Occupied mode, setting of the parameter "Fan ON mode with the Sensor Option" will determine if the Supply Fan is ON continuously, or is in "Auto" mode (i.e. cycles with the heating/cooling cycles). In Unoccupied mode, the fan is always in the Auto mode.

### SUPPLY FAN OFF DELAY

Uses minimum off time.

### CONTROL OF COMPRESSORS WHEN USING A ZONE SENSOR

A Minimum run time of one to ten minutes [default = three] applies to all compressors. The minimum run time is necessary to ensure that the oil in the refrigerant circuit circulates back to the compressor.

The Anti Short Cycle delay of five minutes OFF applies any time compressor operation is terminated. Compressors are turned ON and OFF individually during CV operation with a zone sensor, where the cooling control algorithm is implemented in the controller (rather than in a thermostat).

The stage groups are applicable only for control of compressors with external signals, such as from a thermostat.

There is a minimum 30 second delay between compressors when bringing on multiple compressors.

### HEATING OPERATION WITH THE SENSOR OPTION

The space temperature is controlled to a programmed Unoccupied Heating Setpoint, or to a programmed Occupied Heating Setpoint, as determined by the internal schedule and the state of the Occupied Input (if this input is ON during a scheduled unoccupied time, the unit goes to Occupied Override mode).

The control will use as many as three stages of heat, depending on what heat option is installed.

A zone heating demand of -1.5 °F will generate a request for first stage heat.

A zone heating demand of -2.0 °F will generate a request for second stage heat.

A zone heating demand of -2.5 °F will generate a request for third stage heat. There is a three minute minimum off delay and a thirty second delay between stages.

When the zone temperature is  $-0.1^{\circ}\text{F}$ , or less below the zone setpoint for at least 1 minute, the transition to a satisfied state occurs, the heating stops and the supply fan either continues running, or is turned off after SAT drops below  $100^{\circ}\text{F}$ . The supply fan control in the satisfied state and in the occupied mode is determined by setting of the programmable parameter "Fan ON Mode with the Sensor Option". In the unoccupied mode, the fan is always turned off when the zone is satisfied.

During heating, the SAT control to the selected SAT setpoint is performed using a PI algorithm. Two minute Minimum Run Time and Anti Short Cycle delays applies to all heat stages. There is also a delay of at least one minute between turning on heating stages.

### COOLING OPERATION WITH THE SENSOR OPTION

The control will operate as a two-stage unit.

On two compressor units, compressor one is first stage and compressor two is second stage.

On three compressor units, compressors one and two are first stage and compressor three is second stage.

On four compressor units, compressors one and two are first stage and compressors three and four are second stage.

The control uses a minimum 30-second compressor delay between compressors when bringing on a stage with multiple compressors.

A zone cooling demand  $1.5^{\circ}$  makes a call for first stage cooling.

A zone cooling demand  $2.0^{\circ}$  makes a call for second stage cooling.

If the unit has a demand greater than  $1.5^{\circ}$  but less than  $2.0^{\circ}$ , the control will turn on the first compressor of stage one and load a 5-minute timer. If after 5 minutes the Space temperature is not moving toward the Setpoint, the control will turn on the second compressor of stage one, if available, and wait 5 minutes. The control will continue operating first stage until the Space temperature reaches the Setpoint and then it will turn off the stage one compressor. If after 5 minutes the Space temperature is not moving toward the Setpoint, the control will turn on the first compressor of stage two and wait 5 minutes. The control will continue to turn on compressors using the 5-minute trending timer until the Space Temperature begins to move toward the Setpoint. The control will turn off all the second stage compressors with a 30-second delay between them when the demand reaches  $.5^{\circ}\text{F}$ . The control will continue operating first stage until the Space temperature reaches the Setpoint and then it will turn off the entire stage one compressor.

If the unit starts with a demand greater than  $2.0^{\circ}\text{F}$ , the control will stage up first stage and wait 5 minutes. The control will continue operating first stage until the Space temperature reaches the Setpoint and then it will turn off all the stage one compressors with a 30 second delay between them. If after 5 minutes the Space temperature is not moving toward the Setpoint the control will turn on the first compressor of stage two and wait 5 minutes.

The control will continue to turn on compressors until the Space Temperature begins to move toward the Setpoint using the 5 minute trending method. The control will turn off all the second stage compressors when the demand reaches  $.5^{\circ}\text{F}$  with a 30 second delay between them. The control will continue operating first stage until the Space temperature reaches the Setpoint and then it will turn off the entire stage one using a 30 second delay between compressors if more than one is on.

### VAV OPERATION

The paragraphs below identifies control modes of VAV operation and provides an overview of control methods in all modes. The modes include Occupied and Unoccupied Heating and Cooling and differ depending on the method used to control zone temperature (thermostat, or a space sensor). The heating vs. cooling modes are entered under control of the thermostat, or, in case of space sensor, by control algorithm detecting zone cooling, or heating demand. The "occupied" vs. "unoccupied" modes are controlled by the internal "Occupied/unoccupied" clock and the tables. If a thermostat is connected in addition to the space sensor, it takes priority over the space sensor.

### VAV OPERATION WITH A THERMOSTAT

The thermostat is placed in a selected, representative zone of a VAV system and is used to reset SAT and cycle the VAV unit in cooling and to control heating. It is expected that the thermostat provide  $Y_x$  outputs to control cooling and  $W_x$  output to control heating. The thermostat is expected to provide an output to control occupied/unoccupied mode (a contact closure that supplies in the occupied mode 24 VAC to the "OCC" Input).

As the thermostat has a capability to turn off the unit in occupied cooling mode, it is important to place it in a zone that is representative of the remaining zones, or in a zone with the highest occupied cooling demand.

The VAV zones are controlled by their own zone thermostats to a temperature setpoint set independently of the setpoints of the "system control" thermostat; the setting of the occupied cooling setpoint on the "system control" thermostat should at least roughly correlate to the zone temperature setpoint. For example, the occupied cooling setpoint may be set at, or below the lowest zone temperature setpoint selectable on the zone thermostat. The setpoint setting should prevent a possibility of cooling turned off while other zone(s) in the system still have a cooling demand.

### VAV OPERATION WITH A ZONE SENSOR

The Space Sensor is placed in a selected, representative zone of a VAV system. It is used to reset SAT in cooling and to control occupied heating based on comparison of zone temperature to a programmed "VAV SAT Reset Setpoint". However, since the zone is controlled by its own zone thermostat to a temperature setpoint set independently of the VAV SAT Reset Setpoint, the setting of the VAV SAT Reset Setpoint should at least roughly correlate to the zone temperature setpoint.

For example, the VAV SAT Reset Setpoint may be set at, or below the lowest zone temperature setpoint selectable on the

zone thermostat, in order to prevent a possibility of insufficient cooling while other zone(s) in the system still have a high cooling demand. In unoccupied modes, the Space Sensor controls the unit based on unoccupied heating and cooling setpoints programmed in the unit controller.

The use of a Space Sensor is enabled by setting a programmable parameter "VAV Operation with Thermostat". When the Space Sensor is enabled, the control self-configures to a VAV operation with a Space Sensor if the sensor is available, and to a Return Air Temperature operation if the sensor is not available.

### **STANDALONE VAV OPERATION**

In standalone operation the control unit receives an occupied/unoccupied command from an external source (such as a contact closure on the space sensor input). In occupied cooling mode, it controls to the Low SAT setpoint. In unoccupied mode, the unit shuts down. In unoccupied mode, an external (network) command may be provided to start a Morning Warm-up cycle. The MWU cycle (if enabled) will also start upon a transition from Unoccupied to Occupied mode.

### **SUPPLY FAN OFF DELAY**

Uses fan off delay.

### **OCCUPIED HEATING WITH A THERMOSTAT**

When the unit enters the Occupied mode heating is started by the thermostat turning ON its W1 output. In the Occupied mode the thermostat will control to its occupied heating setpoint. The thermostat's occupied heating setpoint should be set well below the zone thermostat's cooling setpoint, to represent a heating setpoint typical for all system zones.

In VAV heating, full heating (all heating stages ON) occurs when W1=ON, and no heating (all heating stages OFF) occurs when W1=OFF (note that in this case, the control will use all available heating stages, regardless of setting of the programmable parameter "Heat Stages").

The supply fan operates at 100% during heating. Depending on the control setting, the fan will cycle On/Off with the W1 output, or will remain On. On startup, the fan speed is ramped up, or the inlet vanes ramped open (a "soft start").

During occupied heating, the economizer damper remains at minimum position and all VAV boxes are fully open - box heat relays are energized from Heat output of the controller. If Hydronic heat option is used, the Heat output of the controller is also actuated during heating, the SAT is controlled to the 2nd stage hydronic heat setpoint.

### **UNOCCUPIED HEATING WITH A THERMOSTAT**

This operation is identical to the Occupied heating, except the unit mode is in Unoccupied mode from the internal control Occupied/Unoccupied table. The economizer damper remains fully closed in the unoccupied mode.

### **OCCUPIED COOLING WITH A THERMOSTAT**

In this mode, the control uses a thermostat for cooling and fan operation. The thermostat's occupied cooling setpoint should be set below the zone thermostat's lowest adjustable cooling setpoint, to prevent a possibility of cooling turned off while other zone(s) in the system still have a cooling demand.

### **UNOCCUPIED COOLING WITH A THERMOSTAT**

This operation is identical to the Occupied cooling, except when operating in the unoccupied mode the control is programmed to control to its unoccupied cooling setpoint and the economizer damper min. position is set to 0%, however the damper may modulate open if outdoor air can be used for free cooling (economizer operation).

### **OCCUPIED HEATING WITH A SPACE SENSOR**

The Space Sensor is placed in a selected, representative zone of the VAV system, in addition to the zone thermostat, or sensor used to control the zone's VAV box. The heating control algorithm is enabled whenever the zone temperature drops 2 °F or more below a programmed "VAV SAT Reset Setpoint", and disabled whenever the zone temperature is 1.5 °F, or less below a programmed "VAV SAT Reset Setpoint". The "VAV SAT Reset Setpoint" would typically be set at, or below the lowest zone temperature setpoint selectable on the zone thermostat.

The supply fan is controlled to 100% during occupied heating and cycles OFF when the heating control algorithm is satisfied if there is no other call for the fan. On startup, the fan speed is ramped up, or the inlet vanes ramped open (a "soft start").

When a call for heating (W1 or W2=ON) occurs, the economizer damper remains at its programmed minimum position and all VAV boxes go fully open - box heat relays are energized from Heat output of the controller.

If Hydronic heat option is used, the Heat output of the controller is also actuated during heating and the SAT is controlled to the 2nd stage hydronic heat setpoint.

### **UNOCCUPIED HEATING WITH A SPACE SENSOR**

When this mode is enabled and the unit enters the unoccupied mode, the unit will control heating by comparing the zone temperature to a programmed "Unoccupied Heating Setpoint". The Space Sensor should be placed in a selected, representative zone of the VAV system, in addition to the zone thermostat, or sensor used to control the zone's VAV box.

Full heating (all heating stages ON) occurs when the Space Sensor algorithm requests heating, no heating (all heating stages OFF) when the Space Sensor algorithm is satisfied (note that in this case, the control will use all available heating stages, regardless of setting of the programmable parameter "Heat Stages").

The supply fan is controlled to 100% during unoccupied heating and cycles OFF when the Space Sensor control algorithm is satisfied if there is no other call for the fan. On startup, the fan speed is ramped up, or the inlet vanes ramped open (a "soft start").

During unoccupied heating, the economizer damper is fully closed and all VAV boxes go fully open - box heat relays are energized from Heat output of the controller.

### OCCUPIED COOLING WITH A SPACE SENSOR

This mode is entered when the control sees a Space Sensor signal and enters the "occupied" mode. The Space Sensor requests cooling (to a programmed High, or Low SAT setpoint) whenever the zone temperature increases by a specified amount above a programmed "VAV SAT Rest Setpoint". The Space Sensor should be placed in a selected, representative zone of the VAV system, in addition to the zone thermostat, or sensor used to control the zone's VAV box.

The "VAV SAT Reset Setpoint" would typically be set at, or below the lowest zone temperature setpoint selectable on the zone thermostat, in order to prevent a possibility of insufficient cooling while other zone(s) in the system still have a high cooling demand.

The supply fan, economizer, VAV boxes operate within their normal control rules.

### UNOCCUPIED COOLING WITH A SPACE SENSOR

In this mode, the Space Sensor requests cooling based on comparing the zone temperature to a programmed "Unoccupied Cooling Setpoint". When the Space Sensor control algorithm requests cooling, the unit runs cooling controlled to a programmed High SAT setpoint ("VAV Upper Cooling SAT Setpoint"), or to a programmed Low SAT Setpoint ("VAV Upper Cooling SAT Setpoint"), as determined by comparison of zone temperature to a programmed "VAV SAT Reset Setpoint". The "VAV SAT Reset Setpoint" would typically be set well below the "Unoccupied Cooling Setpoint", causing the unoccupied cooling to typically use a Low SAT Setpoint.

There are two different SAT control algorithms, one used when free cooling is available (economizer operation) and the other one for mechanical cooling only. These two SAT control algorithms are described in the "Occupied Cooling in Standalone Operation" section below. Since the economizer is not active in Unoccupied mode, this will be restricted to mechanical cooling.

### UNOCCUPIED HEATING IN STANDALONE OPERATION

Unoccupied heating is never used in standalone operation.

### OCCUPIED COOLING IN STANDALONE OPERATION

The unit controls cooling to a programmed Low SAT setpoint ("VAV Lower Cooling SAT Setpoint") during the occupied mode. There are two different SAT control algorithms, one used when free cooling is available (economizer operation) and the other one for mechanical cooling only. First, when free cooling is available ("economizer suitable"), the SAT control algorithm is as described in the Economizer Operation section later in this document, except the programmed Economizer First Stage Setpoint and Economizer Second Stage Setpoint are replaced by the programmed VAV Upper Cooling SAT Setpoint and VAV Lower Cooling SAT Setpoint.

When free cooling is not available, the SAT control is performed by the following control algorithm: Minimum compressor off times (ASCD) of 5 minutes and minimum on times of one to ten minutes [default is three] are maintained and the cycling rate of the compressors will not exceed maximum 6 cycles/hour. The SAT is controlled in a  $\pm 5$  °F band around the active SAT setpoint. A compressor is allowed to turn on only if the current SAT minus the Predicted SAT Drop is more than 5 °F.

### SUPPLY DUCT PRESSURE CONTROL ALGORITHM

The Supply Duct pressure is controlled to a specified setpoint (see paragraph Duct Pressure Setpoint, section Option Operation earlier in this document). An appropriate closed loop control PI algorithm is used to control the supply duct static pressure by modulating Inlet Guide Vanes, or the supply fan VFD.

### MORNING WARM UP / VAV OCCUPIED HEATING CONTROL ALGORITHM

#### STARTING MORNING WARM UP

Non-networked systems: The MWU (Morning Warm Up) option is enabled by setting the option parameter and establishing a start and end Occupied time period in the control's Occupied 1 weekly schedule.

MWU (Morning Warm Up) is initiated upon all transitions from Unoccupied to Occupied mode. The system clock is used to identify, for the Morning Warm Up, a 1 hour period before actual occupancy begins (also see Intelli-Start). If the MWU option is disabled, the occupancies should be scheduled at their regular time.

An Occupied Override signal will initiate a warm up of up to two hours (the setpoint value of the Unoccupied Override Time Period). It is important to note that the unit is still operating in an Unoccupied mode for the first hour after the occupied Override input is turned on. Reference the Weekly and Holiday Schedule, Tables 8 and 9.

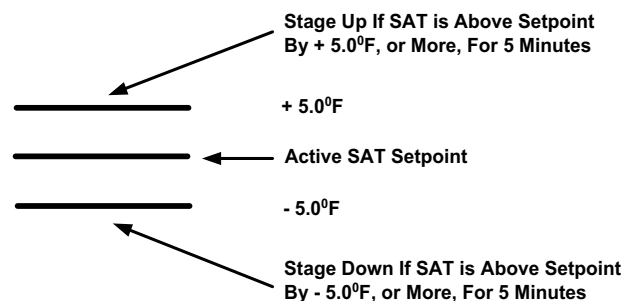

Figure 7: VFD Control Wiring

### MORNING WARM UP/VAV OCCUPIED HEATING FUNCTION

Morning Warm Up controls the RAT to a preprogrammed Morning Warm Up RAT Setpoint. An appropriate closed loop control algorithm is used to control heat stages to accomplish this. The algorithm uses a dead band (i.e. control RAT between the MWU RAT Setpoint and two degrees below the setpoint).

**Table 8: Weekly Schedule**

Times	Mon	Tues	Wed	Thu	Fri	Sat	Sun
Occupied 1	00:00	00:00	00:00	00:00	00:00	00:00	00:00
Unoccupied 1	00:00	00:00	00:00	00:00	00:00	00:00	00:00
Occupied 2	00:00	00:00	00:00	00:00	00:00	00:00	00:00
Unoccupied 2	00:00	00:00	00:00	00:00	00:00	00:00	00:00

**HOLIDAY SCHEDULE**

- If the Start Time is programmed to zero, the default is all day.
- The Number of Days will be programmed from 0-99.
- The Start Date is programmed by Month-Day-Year.
- When the Start Date is 00-00-0000, that Holiday is ignored.
- When the Time is 00:00, the Time is equal to 12:00 a.m., the beginning of the day.

**Table 9: Holiday Schedule**

Holiday Number	Start Month	Start Day of Month	Start Time	Number of Days
Holiday 1	00	00	00:00	00
Holiday 2	00	00	00:00	00
Holiday 3	00	00	00:00	00
Holiday 4	00	00	00:00	00
Holiday 5	00	00	00:00	00
Holiday 6	00	00	00:00	00
Holiday 7	00	00	00:00	00
Holiday 8	00	00	00:00	00
Holiday 9	00	00	00:00	00
Holiday 10	00	00	00:00	00
Holiday 11	00	00	00:00	00
Holiday 12	00	00	00:00	00
Holiday 13	00	00	00:00	00
Holiday 14	00	00	00:00	00
Holiday 15	00	00	00:00	00
Holiday 16	00	00	00:00	00
Holiday 17	00	00	00:00	00
Holiday 18	00	00	00:00	00
Holiday 19	00	00	00:00	00
Holiday 20	00	00	00:00	00

Full heating (all stages) is ON when RAT drops 2 °F below the setpoint, heating is OFF when RAT is at, or above the setpoint. (Note that in this case, the control will use all available heating stages, regardless of setting of the programmable parameter "Heat Stages"). Before energizing heat for Morning Warm Up the control will start the Fan and operate it for 5 minutes. The Economizer will stay closed and the Fan will continue to run during the Morning Warm Up. The Morning Warm Up will terminate when the Occupied period begins.

If the RAT setpoint is achieved before the MWU period expires, Unoccupied cooling is permitted. If further heating is needed during the Occupied period, it is controlled by a VAV Occupied Heating algorithm (if enabled and if a Space Sensor is used), or by a space thermostat.

The same algorithm is also used for VAV Occupied Heating (see also paragraph "VAV Occupied heating" in "Option Operation" section earlier in this document). In this case, the VAV Occupied Heating control algorithm is activated under the control of the Space Sensor (whenever the zone temperature sensed by the Space Sensor drops 2 °F or more below a programmed "VAV SAT Reset Setpoint"). Once activated, the Occupied Heating control algorithm controls RAT between the MWU RAT Setpoint and two degrees below the setpoint and cycles the fan the same way as the MWU algorithm.

The specified Max Morning Warm Up Time is not used to limit the duration of VAV Occupied Heating. During heating for Morning Warm Up, or for VAV Occupied heating function, the VAV boxes controls will receive an override signal to open the VAV box damper. This is accomplished by wiring the VAV heat relay for the VAV boxes to open, and energizing it from Heat output of the controller. Note that as the first stage of heat cycles on / off, the VAV box heat relay will cycle with it.

**UNOCCUPIED VAV HEATING / COOLING CONTROL ALGORITHM WITH A SPACE SENSOR**

In the unoccupied mode, the Space Sensor will compare the temperature in a selected VAV zone to the programmed Unoccupied Heating and Cooling setpoints and request heating or cooling using the following control algorithm:

**OCCUPIED VAV HEATING / COOLING CONTROL ALGORITHM WITH A SPACE SENSOR**

In the occupied mode, the control will compare the temperature in a selected VAV zone to the programmed "VAV SAT Reset Setpoint" and request heating or cooling using the following control algorithm: The transition from cooling to occupied heating occurs at 2 °F below the "VAV SAT Reset Setpoint". There is no "satisfied", or "idle" state of the unit between cooling and occupied heating.

The above algorithm only requests occupied cooling and selects a SAT occupied cooling setpoint, or requests occupied heating at a programmed "Morning Warm Up RAT Setpoint".

Once requested by this Space Sensor algorithm, the cooling is controlled by the SAT control algorithm described in paragraph "SAT Control Algorithm in VAV Cooling" earlier in this section

[not to be found by that name...]. Once requested by this Space Sensor algorithm, the occupied heating is controlled by the RAT control algorithm described in paragraph "Morning Warm Up / VAV Occupied Heating Control Algorithm" earlier in this section.

## **CONTROLLING EXCESSIVE SAT (SUPPLY AIR TEMPERATURE)**

This is required in cooling operation in order to prevent a danger of "slugging" and damage to the DX compressors. Rooftop units do not use accumulators on compressor intake, and liquid refrigerant could enter the intake of a compressor in case of a low heat transfer on the evaporator coil. In heating operation, the Excessive SAT control is not used.

### **SAT CONTROL CONFIGURATION**

SAT control for cooling is configurable to enable or disable (on/off). The default setting for cooling is ON. The user is not normally expected to turn this mode OFF, but the possibility of turning it OFF is provided mainly for troubleshooting purposes.

### **SAT CONTROL FOR COOLING**

This control has priority over any other zone temperature or SAT control and is used at all times, during CV as well as VAV operation. The Excessive SAT Control state is entered any time the SAT drops below the trip point of a compressor (as the trip points are programmed in an ascending sequence, the compressor that trips will always be the highest- numbered one).

While in this state, the control will continue monitoring the SAT and turning off compressors any time the SAT drops below the respective trip point. There is a 2 minute time delay between compressor trips in cases when the SAT drops below trip points of multiple compressors. This assures that multiple compressors will not be turned off simultaneously.

### **ECONOMIZER LOADING OPERATION DURING AN EXCESSIVE SAT FOR COOLING:**

#### **CV ECONOMIZER OPERATION**

Economizer dampers allow mixing of outdoor and return air. The dampers are coupled and controlled with a single actuator such that when the Outdoor Air damper is fully closed, the Return Air damper is fully open (and vice versa). The position of the Economizer dampers is controlled based on:

- Energy considerations ("free cooling")
- Ventilation considerations (minimum Outdoor Air damper position and Demand Ventilation)
- Space static pressure considerations (minimum Outdoor Air damper position).

Economizer dampers are also controlled in certain situations to perform "economizer loading" - which minimizes SAT temperature swings resulting from turning cooling, or heating stages on / off. This function is separate from normal economizer operation, and is separately described at the end of this section.

#### **When is the Economizer operation used?**

If the rooftop unit is equipped with an economizer (and that option is selected), and free cooling is available ("economizer

suitable"), then the Economizer Operation as specified in this section will be used in the following operation modes:

CV cooling with thermostat, or zone temperature sensor control (note that in the zone sensor mode, the compressor staging algorithm defined in this Economizer section will replace the zone sensor based control described in Sensor Operation in CV Operation section, earlier in this document).

#### **Minimum Ventilation Position setting**

The minimum position setting represents the minimum opening of the outdoor air damper (% open). This setting will be maintained any time the unit is in Occupied mode. The minimum position setting will be determined by an "Economizer Min Position" programmable parameter set by a Palm Pilot. The minimum position setting will be ignored during the Unoccupied mode. During the Unoccupied mode, the minimum position is 0% (the Economizer may not remain closed during the Unoccupied mode, in case the temperature control to an unoccupied setpoint can use Outside Air for free cooling).

#### **Minimum Position during Heating and Occupied Mode**

During heating while in Occupied mode, the economizer will be at its programmed minimum position.

#### **Minimum Position during Cooling and Occupied Mode**

During cooling while in Occupied Mode, the economizer may be at its programmed minimum or may be modulated between its minimum position and 100% open position by the economizer control.

### **SAT SETPOINTS USED DURING COOLING WITH ECONOMIZER OPERATION**

As long as the Economizer Operation is enabled and "free cooling" is available, the economizer will be controlled (with, or without any compressors running) to maintain the following SAT setpoints: In CV cooling mode:

- With a call for first stage cooling, a programmed Economizer First Stage Setpoint. This setpoint is programmable in the range of 40 °F to 65 °F, default setting is 55 °F.
- With a call for second stage cooling, a programmed Economizer Second Stage Setpoint. This setpoint is programmable in the range of 40 °F to 65 °F, default setting is 50 °F.

#### **Criteria for Economizer Suitable decision Sensor availability:**

There are three different methods of deciding whether the economizer is suitable:

- **Differential enthalpy** (highest preference from energy viewpoint)
- **Outside enthalpy** (middle preference) and
- **Outside temperature method** (lowest preference)

The choice of a method with highest preference is automatic ("self-configuration") based on availability of appropriate sensors. If a sensor fails/ goes unreliable, a fault is indicated and, again, the next highest preference method will be automatically selected ("fault tolerance").

There are two ON/OFF programmable parameters related to the choice of an economizer method:

- “OAH Sensor Enable”
- “RAH Sensor Enable”

These parameters are set to reflect the installed sensors that can be used by the “self-configuration” feature and control sensor failure alarms.

The OAH sensor, if available, allows use of Outside Enthalpy method for deciding on free cooling availability.

The RAH sensor, if available in addition to the OAH sensor, allows use of Differential Enthalpy method for deciding on free cooling availability.

See paragraphs OAH Sensor Enable and RAH Sensor Enable in Settable Parameters, Table 5 in this document.

If the selected method is using an enthalpy, the enthalpy is calculated in the controller from sensed temperature and humidity of the respective air stream.

**Differential Enthalpy Method:** is set by parameter and used only when sensors for Outdoor Air temperature, Outdoor Air humidity, Return Air temperature and Return Air humidity are all installed and reliable.

**Outside Enthalpy Method:** will be configured by setting ON the parameter for the Outdoor Humidity Sensor [OAH], and will be the default if the unit defined as Differential Enthalpy cannot read the Return Air Humidity sensor.

**Outside Temperature Method:** will be self-configured and used only when differential enthalpy or outside enthalpy methods are not available, and sensor for Outside Air temperature is installed and reliable.

Economizer is suitable when OAT is less than SAT setpoint + 10 °F. Use a 2 °F differential on both sides of this limit. As the SAT setpoint value, use only one of the programmed 1st or 2nd stage economizer setpoints (depending on what cooling stage is called), not any “transient” setpoints that may be temporarily used during process of staging. Note that this rule does not reflect any consideration of geographical location and weather conditions, but rather reflects the average expected SAT temperature drop obtained from DX cooling stages, i.e. the highest outdoor air temperature that the DX cooling can still reliably reduce to the SAT setpoint

**Outside Enthalpy Method:** Economizer is suitable when OA Enthalpy is less than Outside Enthalpy number AND OAT is less than SAT setpoint + 10 °F: Use a 2 °F and 1 BTU/LB differentials respectively on both sides of these limits. The Enthalpy number is a programmed parameter (range 22-40 BTU/LB, default 30 BTU/LB). The Enthalpy Number can be viewed as the maximum outdoor air enthalpy with which the outside air can still be considered suitable for DX cooling, or, in comparison to the Differential Enthalpy Method described below, as a “best guess” on actual return air enthalpy (which in this method is not being sensed). The temperature limit reflects the average expected SAT temperature drop obtained from DX cooling stages.

**Differential Enthalpy Method:** Economizer is suitable when OA Enthalpy is less than the RA Enthalpy AND OAT is less than SAT setpoint plus 10 °F (+/- 2 ° and 1 BTU/LB): Use a 2 °F and 1 BTU/LB differentials respectively on both sides of these limits. This is similar to the Outside Enthalpy method, except instead of a programmed Enthalpy Number, an actually sensed return air enthalpy is used.

### SAT Control with Economizer

If the economizer is “suitable” (free cooling is available) and cooling is required (the unit is not in satisfied state), the algorithm will be active and modulate economizer position in order to control SAT to the active SAT setpoint. If the economizer is not suitable, the algorithm is deactivated and the economizer is placed at its programmed minimum position. The economizer control algorithm will typically be cycled ON/OFF several times an hour (will be activated and deactivated) under control of a zone thermostat, or a zone sensor. A zone control algorithm will activate the economizer algorithm when cooling is required, and will switch between Economizer 1st and 2nd stage SAT setpoints, and will deactivate the economizer algorithm when the zone is satisfied.

The PI algorithm is direct acting. This economizer control algorithm is always active during economizer operation (as long as economizer is “suitable”) and will control SAT to an active (1st or 2nd stage) Economizer setpoint. This means that this control loop not only modulates the Outside Air damper open to add free cooling and decrease mixed air temperature to maintain SAT at setpoint, but, when DX cooling is running, also may modulate the Outside Air damper closed to increase mixed air temperature (use more return air) and thus add load on the DX coil to maintain SAT at setpoint (“economizer loading”). This represents a trade-off between energy and compressor cycling.

### Control of compressors with Economizer

Compressors are turned ON / OFF individually, regardless of grouping them into “stages”. The stage groups are used only for control of compressors with external signals, such as from a thermostat.

#### Turning ON of compressor #1:

Never operate compression if the Economizer can maintain the SAT setpoint with free cooling. If no compressors are on, and the economizer controller is saturated High (i.e. the economizer is 100% open and can no longer maintain the SAT setpoint by just free cooling),

- Temporarily override SAT setpoint to increase it by 5 °F
- When the SAT is within 0.5 °F of this temporary setpoint, turn on compressor #1
- Resume SAT control at active setpoint

This is done in order to read and store the SAT temperature differential (drop) due to turning on compressor #1, while assuring that turning it on will not drop the SAT below compressor #1 trip point (where the Excessive SAT control would turn it off again). The same staging sequence is used for the remaining compressors (see below). Note that the standard 5 minute delay before monitoring SAT after a compressor is turned on, or off, applies here also.

### Turning on compressors #2 through #4:

If the economizer controller is saturated High (i.e. the economizer is 100% open while one or more compressors are running and the control can no longer maintain the active SAT setpoint requested by the zone control),

- Temporarily override SAT setpoint to increase it by 5 °F
- When the SAT is within 0.5 °F of this temporary setpoint, turn on the next compressor
- Resume SAT control at active setpoint

**NOTE:** The pre-staging SAT increase must be done "pro actively", by a temporary override of the active SAT setpoint, rather than by allowing the SAT to "drift" up by 5 °F out of control. The time it would take for the SAT to "drift" up could be fairly long, mostly dependent on the outdoor air temperature change and in the meantime, the zone temperature may go out of control as the additional needed cooling is not being delivered.

**NOTE:** The standard 5 minute delay before monitoring SAT after a compressor is turned on, or off, and the checking against a stored, predicted SAT temperature drop, applies here also.

### Turning compressors off:

A highest numbered running compressor is turned off when the economizer controller is saturated Low.

This method of turning compressor off is considered better than using the Excessive SAT Control - turning a compressor OFF only if SAT reaches its specified trip point. If that method was used and the Excessive SAT Control was not selected, there would be no means for turning compressors off.

**NOTE:** The compressors also will be turned off in CV systems with zone thermostat, or zone sensor temperature control, when the zone temperature control is satisfied. For the case of zone sensor, the compressor destaging is described in section "CV Operation", paragraph "Control Algorithm for Cooling with the Sensor Option, with Economizer". For the case of zone thermostat, the compressor destaging is described in section "CV Operation", paragraph "Thermostat Operation for Cooling with Y1 and Y2 inputs", subparagraph "Economizer Mode".

### Compressor control when exiting Cooling Lockout on OAT:

A situation may arise when in Economizer Mode and one or more compressors are required in addition to full available free cooling in order to maintain the SAT setpoint, but Cooling Lockout on OAT prevents the compressors use. This situation may arise when the SAT setpoint is set very close to, or even below the temperature set for Cooling Lockout on OAT - a relatively unusual case. If the OAT then increases above the lockout setting while the call for several compressors exists, the compressors will turn on with a delay between compressors.

### Economizer Loading Option

This is a programmable option. The user has the ability to turn this function off. It is automatically disabled if the unit does not

use an economizer. The on/off programming choice is common to both cooling and heating. The default setting is ON. This programmable "Economizer Loading" function is used only outside the normal Economizer operation.

During the Economizer operation, the "Loading" function is always used and is an integral part of the Economizer control algorithm.

### Economizer loading option in cooling:

In cooling, this function causes changes in mixed air temperature (as modulated by the economizer dampers) in order to change SAT and keep it at SAT setpoint when only compressor #1 is running. This makes a trade-off between energy and compressor cycling and minimizes cycling of compressor #1. The loading is done by the same type of control algorithm (PI) as used in the normal Economizer operation.

The algorithm will be activated to do this function in following conditions:

- Economizer is "not suitable" (i.e. we are not in a normal Economizer mode)
- The programmable option "Economizer Loading to Control SAT" is ON
- Only compressor #1 is running

The PI control algorithm in this case has a capability to automatically change from direct to reverse acting in response to difference between OAT and RAT. When OAT is less than RAT, the algorithm is direct acting, for OAT & RAT, the algorithm changes to reverse acting. This way, the "loading" of the DX coil is correctly done with return, or outdoor air, as appropriate, and there is no need to activate this "loading" function only at higher outdoor air temperatures (e.g. OAT > 60 °F).

The algorithm controls SAT to its specified setpoint (when applicable, e.g. in VAV operation), or, in control modes where no SAT setpoint is specified (such as in Excessive SAT control state in cooling), to a fixed temperature deadband of 50 °F to 55 °F.

**NOTE:** As opposed to the PI algorithm used in economizer control, the PI algorithm used here for economizer loading function does not need to utilize the High saturation state for any additional control functions. Therefore no complications arise when switching between direct and reverse acting modes.

### Economizer loading option in heating:

In heating, this function uses additional outside air (as modulated by the economizer dampers) in order to decrease SAT when only the first stage of heating is running and keep the SAT below the programmed "Economizer Loading Setpoint in Heating". This prevents heating stage from cycling on its internal temperature limit safety switch (which is typically set about 10 °F above the Economizer Loading Setpoint). A need for economizer loading arises in Communicating Zoning System applications ("VVT" systems) using supply air bypass when heating load in the zones is low and a large amount of hot supply air is bypassed back into return and mixed air temperature is very high. Economizer loading may also be needed when supply air flow across the heat exchanger is lower than expected (e.g. wrong setting of fan

speed, plugged air filters). A secondary benefit of economizer loading is an improvement in comfort as the supply air temperature is more stable and cycling of the unit is minimized.

The economizer loading option in heating is not implemented in VAV applications as these do not use supply air bypass and (in case of using a zone thermostat) run all heating stages during heating (economizer loading applies to only the 1<sup>st</sup> heating stage).

The economizer loading minimizes cycling of heating stage #1 and makes a trade-off between energy and the benefits described above.

The Economizer Loading in heating option requires a SAT sensor that can sense SAT in heating mode (a sensor placed downstream of the heating stages). Such a sensor is provided only as a field-installed accessory, on units equipped with heating stages. The SAT sensor that is factory-installed can be used for cooling mode only. If a field-installed sensor is added, it will replace the factory-installed one and will then be usable for both heating and cooling modes.

The loading is done by the similar control algorithm as used in the normal economizer operation. The algorithm is activated to do this function in following conditions:

- Heating mode
- The programmable option "Economizer Loading to Control SAT" is ON
- Only heating stage #1 is running

The PI control algorithm in this case has a capability to automatically change from direct to reverse acting in response to difference between OAT and RAT. When OAT is less than RAT the algorithm is direct acting, when OAT is greater than RAT the algorithm is reverse acting.

This way, the "loading" of the heating stage is correctly done with return, or outdoor air, as appropriate, and there is no need to activate this "loading" function only in some specific range of outdoor air temperatures (e.g. OAT > programmed first heating stage trip point minus 50 °F).

**NOTE:** In this case, the provision for direct vs. reverse acting switching is not essential feature of the control algorithm and the algorithm could be implemented as direct acting only in order to simplify implementation and save code space. The situation when economizer loading in heating is required while OAT greater than RAT is unlikely and if it should occur, the difference between OAT and RAT is negligible in comparison to the SAT control setpoint. The Economizer Loading function in heating controls SAT to a fixed temperature deadband of programmed "Economizer Loading Setpoint in Heating" and 5 °F below this setpoint (the setpoint is programmable between 100 °F - 195 °F, default is 160 °F).

In units that use hydronic heat, the Economizer Loading function may be enabled in order to be used for cooling (the on/off

programming choice for this function is common to both cooling and heating). In this case, it is important to ensure that the programmed value of the "Economizer Loading Setpoint in Heating" is set higher than the value of "Hydronic Heat First Stage Setpoint". That, in normal conditions, assures that the Economizer Loading function in heating is effectively disabled and the economizer is closed to its minimum position during heating.

## VAV

When is the Economizer operation used? If the rooftop unit is equipped with an economizer and free cooling is available then the Economizer Operation as specified in this section is used in the following operation modes:

VAV cooling (except the programmed Economizer First Stage Setpoint and Economizer Second Stage Setpoint are replaced by the programmed VAV Upper Cooling SAT Setpoint and VAV Lower Cooling SAT Setpoint)

## DEMAND VENTILATION

Demand Ventilation Operation control mode is self-configuring for the use of an Indoor Air Quality (IAQ) sensor - it will automatically detect that an IAQ sensor is connected and use it any time the IAQ sensor input indicates an IAQ level of 200 ppm, or higher.

**NOTE:** Due to the self-configuration operation, an error due to IAQ sensor failure can be indicated only in case the IAQ sensor fails during normal controller operation. If the IAQ sensor fails, or is removed / disconnected during a power-off condition (e.g. during servicing of the unit while the control is not powered), the control will, on power up, self configure without the IAQ sensor and no error indication is provided.

When the IAQ sensor is detected as available, the control will use the Demand Ventilation Setpoint to control the IAQ levels in the building by modulating the Economizer more open.

The Demand Ventilation will operate in units equipped with an Economizer (Economizer option is turned ON) any time the control is in Occupied mode. The Demand Ventilation Operation is applicable in heating, or cooling mode, and will modulate the Economizer damper more open, if necessary, from its programmed minimum position (in heating, or in cooling when economizer is not "suitable"), or from its modulated position determined as defined in the Economizer Operation section (in cooling, when economizer is "suitable").

An appropriate control algorithm is used to accomplish this control. Preferably, this algorithm is a "step-and-wait" type, with the step size calculated as a function of offset between the Demand Ventilation Setpoint and the current IAQ level, and with a fixed "wait", or sampling time. This algorithm is activated whenever the IAQ level exceeds the setpoint and will override the economizer position more open, as needed, up to a pre programmed Maximum Economizer Position for Demand Ventilation. The algorithm is deactivated, and the previous, normal mode of economizer position control resumed when the IAQ level becomes 50 ppm lower than the setpoint.

The programmed "Maximum Economizer Position for Demand Ventilation" is used to minimize the possibility that the Demand Ventilation may open the Economizer damper too much, such that at fairly high OA temperatures, even combined cooling output of all compressors would not provide sufficient cooling (as a rule of thumb, all compressors combined achieve approx. 20 °F SAT decrease). Similarly, at fairly low OA temperatures, the combined output of all heating stages may not be able to provide sufficient heating. This Economizer max. position limit is simpler to implement than a closed loop SAT low-limit control that would operate with a programmed high-limit for cooling and a programmed low limit for heating.

**NOTE:** An added measure of protection against excessive SAT during Demand Ventilation Operation is provided by Supply Air Alarm Setpoint for Cooling and Supply Air Alarm Setpoint for Heating, and the control function associated with these setpoints (see the respective paragraphs in the Option Operation section earlier in this document).

## EXHAUST OPERATION

Building static pressure is controlled through one of three methods. One method incorporates a fixed speed fan that is controlled from the position of the Economizer dampers. A second method uses proportional control that modulates the exhaust damper and operates the fan based on the position of the dampers. A third method uses a variable speed fan control that looks at building static pressure. All are dependent on the supply fan being ON.

### TWO-POSITION CONTROL (NON MODULATING POWER EXHAUST)

This mode is a fixed speed, ON/OFF Power exhaust fan, with a barometric relief damper, controlled from position of the Economizer damper. The Power Exhaust and the Economizer options must be ON.

This mode is a fixed speed, ON/OFF Power exhaust fan, with a barometric relief damper, controlled from position of the Economizer damper. The Power Exhaust and the Economizer options must be ON.

The Exhaust Fan (EF) is controlled with a relay output of the controller and "slaved" to the Economizer damper position value.

The EF relay is energized whenever the Supply Fan is running and the Economizer (Outdoor Air Damper) is commanded open more than the programmed Economizer Damper Position for Exhaust Fan to turn ON.

The EF will be de-energized when supply fan is off or when the OAD opening is less than the EF Turn OFF set point or 10% open, whichever is greater. Default Setpoint settings for the EF to turn ON at Economizer 60% open, turn OFF at Economizer 20% open. The EF has a minimum run time of 10 seconds and a minimum off time of 60 seconds.

### PROPORTIONAL CONTROL (FAN WITH MODULATING EXHAUST AIR DAMPER (EAD) CONTROLLED FROM BUILDING STATIC PRESSURE)

In this mode the Power Exhaust, Modulating Exhaust, Economizer and Building Pressure Sensor Enable options must be ON and the Supply Fan must be running. The EAD actuator is modulated to maintain building static pressure to a programmed Building Pressure Setpoint. An appropriate closed loop control algorithm is used to accomplish this control.

The control will modulate from full closed to full open over a 2-minute period. The proportional band is from 0.015 in. w.g. (3.7 Pa) below the Building Pressure Setpoint to 0.015-in. w.g. (3.7 Pa) above the set point.

The control algorithm is disabled and exhaust air damper commanded closed whenever the supply fan is off. Building pressure is sensed with a -0.250 to +0.250 in. w.g. (-31 to + 31 Pa) 0 - 5V output pressure differential transducer. The transducer senses the building pressure as referenced to an appropriate reference point outside the building. Transducer output signal is filtered (e.g. time averaged over 15 second period) to compensate for wind gusts.

The Exhaust Fan (EF) is controlled with a relay output of the controller and "slaved" to the Exhaust Air Damper position. The EF relay is energized whenever the Supply fan is running **and** the EAD is open more than the programmed Exhaust Damper Position for Exhaust Fan to turn ON. The EF relay is de-energized when Supply fan is off or when the EAD opening is less than the programmed Exhaust Damper Position for Exhaust Fan to turn OFF, or 10% open, whichever is greater. The minimum run time is 10 seconds and minimum off time is 60 seconds. (Non-adjustable). Default Setpoint settings are for the EF to turn ON at Exhaust Air Damper 80% open and turn OFF at Exhaust Air Damper 20% open. The Building Pressure Setpoint default is 0.100" w.g.

### PROPORTIONAL CONTROL WITH VFD FAN

This is similar to the proportional EAD option, except that the damper signal is used to control motor speed using a variable frequency drive.

### TWO-POSITION CONTROL (POWER EXHAUST WITH BAROMETRIC RELIEF, CONTROLLED FROM BUILDING STATIC PRESSURE)

In this mode the Power Exhaust, Economizer and Building Pressure Sensor Enable options must be ON. The Exhaust Fan (EF) is controlled with a relay output of the controller. The EF relay is energized whenever Supply fan is running and building static pressure is above a programmed Building Pressure Setpoint + 0.015 " w.g. (3.7 Pa). The EF relay is de-energized when supply fan is off, or when building static pressure is less than a programmed Building Pressure Setpoint - 0.015" w.g. (3.7 Pa). The minimum run time is 10 seconds and minimum off time 60 seconds (Non-adjustable). With this type of control, the Power Exhaust fan cycle, as its operation directly influences the building static pressure that controls it. The cycling rate is

limited by these minimum ON and OFF time settings. The Building Pressure Setpoint default is 0.100" w.g.

## ERV

During operation, the ERV [Energy Recovery Ventilation] exhausts return air from the building, but it is not a 'power exhaust'; the system is NOT controlled by building pressure. If building pressure control is required, it must be done by other means - standalone power exhaust, or power exhaust in another unit serving the same space.

The ERV forces high volume fresh air exchange, but captures the heat energy of the outgoing air and transfers it to the incoming stream. ERV blower operation is NOT modulated to a pressure setting; there is no building pressure transducer in the system. The unit's supply fan pulls air through the inlet side of the ERV wheel.

Ducting and demand will vary from one installation to another. Adjusting the unit to achieve fresh air requirements and 'exhaust-neutral' air flow must be done by the installer, using the manual dampers in the unit.

If the unit is variable air volume, the ERV exhaust motors will be controlled by a variable frequency drive in the Millennium, using the same signal voltage that modulates supply air, either by inlet guide vane or variable frequency drive. This is done to keep supply and exhaust air flow in balance.

The exhaust blowers in the ERV use the power and control hardware that otherwise would run the power exhaust. The EXH output from the control board runs the ERV motors; if the unit is VAV, the EXD+/- terminals provide the ERV variable frequency drive speed signal.

Where a unit has both ERV and an economizer, the ERV will stop wheel rotation when the economizer dampers open far enough to trigger the user-settable switch in the damper actuator. If free cooling is available, the heat exchange wheel does not need to rotate; the wheel will cycle on schedule to keep the air passages blown clean.

Also refer to the ERV Installation Instructions packaged with the ERV.

## SCHEDULING OPERATION

The Series 40 controls refers to its clock and internal calendar.

## COMPRESSOR STATUS MONITORING

Compressor status is monitored using three separate 24 VAC circuits.

Monitoring: low pressure, high pressure, and compressor modules.

The corresponding compressor status is monitored. If any of the three safeties is in error, the trip is noted in the alarm history and the next available compressor will be used if needed.

The Low Refrigerant Pressure Switch is Normally Open, pressure closed. When the compressor is off and refrigerant pressure equalized, the switch under normal conditions is expected to be closed. However, in cold ambient operation, it may stay open and close only after the compressor starts up.

If an error is detected for a compressor, that compressor's output is turned off (note that the controller executes the application code once every 32ms, with a 30 second startup delay and 5 second minimum error time on low pressure. The control then declares a "Compressor Locked Out on [ ] Trip" alarm. The alarm is written to the Error History Buffer.

**NOTE:** The compressor lockout works as an override of the output of the staging algorithm for cooling control. For example, the cooling control may ask for compressor #2 that is locked out, and as this request does not generate additional cooling, will ask for the next compressor, #3, to satisfy the cooling demand. If, after 10 minutes, the requested compressor #2 does start up, the cooling output now may be exceeding demand, and the control will turn off compressor #3, etc.

**Table 10: Alarm Default Codes**

Code	Cause
1	Compressor number one locked out on High Pressure Control
2	Compressor number two locked out on High Pressure Control
3	Compressor number three locked out on High Pressure Control
4	Compressor number four locked out on High Pressure Control
5	Compressor number one locked out on Low Pressure Control
6	Compressor number two locked out on Low Pressure Control
7	Compressor number three locked out on Low Pressure Control
8	Compressor number four locked out on Low Pressure Control
9	Compressor number one locked out on excessive motor trips
10	Compressor number two locked out on excessive motor trips
11	Compressor number three locked out on excessive motor trips
12	Compressor number four locked out on excessive motor trips
13	First stage heating is locked out due to excessive Limit Switch Trips
14	Second stage heating is locked out due to excessive Limit Switch Trips
15	Third stage heating is locked out due to excessive Limit Switch Trips
16	First stage of heating is locked out because the ignition board failed to turn on the gas valve after 5 minutes of operation or the gas valve has voltage on it and the control is not calling for this stage of heating
17	Second stage of heating is locked out because the ignition board failed to turn on the gas valve after 5 minutes of operation or the gas valve has voltage on it and the control is not calling for this stage of heating
18	Third stage of heating is locked out because the ignition board failed to turn on the gas valve after 5 minutes of operation or the gas valve has voltage on it and the control is not calling for this stage of heating
19	Space Temperature Sensor has failed open or shorted
20	Supply Air Temperature Sensor has failed open or shorted
21	Return Air Temperature Sensor has failed open or shorted
22	Outside Air Temperature Sensor has failed open or shorted
23	Dirty Filter Switch has tripped
24	Unit has locked out on the APS. Air Pressure Switch.
25	The APS is stuck closed.
26	A microelectronics failure has occurred and the control is operating on defaults
27	A microelectronics failure has occurred and the control is down due to a fatal fault.
28	The control is locked out due to Fan Overload Trips
29	Outside Humidity Sensor is out of Range
30	Return Air Humidity Sensor is out of Range
31	IAQ Sensor is out of Range
32	Real Time Clock cannot be read and has a hardware failure
33	Space Temperature Offset is greater than 20K Ohms
34	CV/VAV input is out of range and the unit is locked out
35	Unit is locked out due to low voltage on the 24 VAC supply
36	Smoke Purge
37	Duct Static has Exceeded Limit
38	Supply Air Temperature Cooling
39	Supply Air Temperature Heating
40	Economizer Minimum Position
41	Space Temperature
42	Faulty Duct Static Pressure Sensor / Low Reading
43	Freeze Stat Trip

## TROUBLESHOOTING A SERIES 40 UNIT CONTROL

### STATUS LED CHART

The Status LED mounted on the controller PC board will flash specified flash patterns to indicate rooftop unit status. See Table 11.

**Table 11: Status Led Chart**

Flash Codes	Description
On Steady	Control Failure
1 Flash	(Not Applicable)
2 Flashes	Control waiting ASCD
OFF	No Power or Control Failure

#### Flash Times:

- **Off:** The power is Off, or the control has failed
- **On 250ms Off 250ms:** The Control is operating but an Alarm is active.
- (The Number of the Alarm will be displayed on the character display.)
- **On one second, Off one second:** This will be the "Heat Beat"; The Control is operating normally with no Alarms.
- **On Steady:** The Control has Failed
- **Two flashes On, then two seconds Off:** The Control is waiting for an ASCD Timer to finish.

## FAILURE MODES AND DEFAULT OPERATION

### ERROR HISTORIES

Error data storage: The control will store the latest five errors in a FIFO manner in EEPROM, for later display. It will store status information ("active" vs. "inactive") for all error types to provide for situations when an error snapshot is triggered by multiple errors occurring at the same time. As the control collects errors, it will overwrite the oldest error after the history buffer becomes full.

#### Errors that are entered into the error history buffer:

- Compressor locked out on safety chain trip
- Supply fan failure
- Heating SAT failure
- Cooling SAT failure
- SAT,RAT,OAT,IAQ, ST, or RH failure
- Duct static or Bldg. Pressure sensor failure
- Dirty Filter alarm
- High duct static alarm
- Hot Water Coil Freeze alarm
- External alarm input
- Bad Air Proving Switch

## SENSOR FAILURES AND DEFAULT OPERATION

A failure of SAT RAT, OAT, IAQ, Space Temperature, or an outside or return air Relative Humidity sensor will generate a common error. A failure of the Duct Static or Building Pressure sensor will generate another common error. The errors will be indicated by a Status LED (see Status LED Chart earlier in this chapter). The errors will be written to the Error History Buffer. In networked application, the error flag will be readable by the network. The error indication of a sensor failure will continue until the problem is corrected and will automatically terminate when the sensor is again detected as reliable. If the unit is shut down as a result of a sensor failure, the alarm must be reset (after the sensor problem has been corrected) by resetting the controller (power cycle, or reset command issued by the Palm Pilot Configuration Tool).

### SAT SENSOR

**CV operation:** If the SAT sensor fails, the Economizer, excessive SAT control and predicted SAT drop checking will be disabled. The Control will then continue a "limp along" operation under zone thermostat, or zone sensor control. For VAV operation the unit will be shut down.

### RAT SENSOR

If the RAT sensor fails, Morning Warm Up mode and VAV Occupied Heating are disabled. For Economizer Loading function, the control will default to estimated RAT of 75 °F (for this function only).

### OAT SENSOR

**Units without Economizer:** If there is no Economizer, the control will lockout Cooling on an OAT sensor failure. This is because the controller can not determine when cooling needs to be locked out at low OAT to prevent damage to compressors. Heating operation will continue normally.

**Units with Economizer:** All Economizer Operation will be disabled. This is because OAT sensor is the most essential sensor in determining availability of free cooling. Even if the unit is equipped with Outside RH sensor and controller could calculate Outdoor Enthalpy, the OAT sensor is still essential in that calculation. The Economizer will only modulate to the Minimum Position when the Fan is operating and the control is Occupied.

### OUTSIDE AIR RELATIVE HUMIDITY SENSOR

If the OAH sensor fails, the control will only use the OAT sensor to decide if Free Cooling is available. The control will self-configure to Outside Temperature Method (see also Economizer Operation section earlier in this document).

### RETURN AIR RELATIVE HUMIDITY SENSOR

The control will self-configure to Outside Enthalpy Operation.

### SPACE TEMPERATURE SENSOR

**CV operation with a zone sensor:** When this sensor fails the control will see if it has a RAT sensor. If it has a RAT sensor, the control will use it as a backup and continue temperature control

to the active space temperature setpoint. If there is no RAT Sensor, the control will shut down all outputs. If the detected sensor failure is a short circuit, the error can be declared only if the short persists for several minutes, in order to distinguish a sensor failure from a short caused by somebody pushing on Unoccupied Override button.

**VAV operation:** If the space temperature sensor fails, the control will continue normal function, only SAT reset from space temperature will be disabled.

#### **BUILDING PRESSURE SENSOR**

If this sensor fails, the Power Exhaust control will default to operate as a two position Power Exhaust. The Power Exhaust Fan will be controlled as a fixed speed, ON/OFF Power exhaust fan, controlled from position of the Economizer damper. If the unit is equipped with a Modulating Exhaust Air Damper, this damper will be closed.

#### **DUCT STATIC PRESSURE SENSOR**

If this sensor fails, all outputs are turned off and the unit is shut down.

#### **IAQ SENSOR**

If the IAQ sensor fails, Demand Ventilation mode is deactivated.

#### **SYSTEM ERRORS**

##### **HEATING SAT FAILURE**

In Heating mode and all stages of heating energized, the SAT must drive above the Supply Air Alarm Setpoint for Heating within ten minutes or this SAT failure error will be activated. The error will be written to the Error History Buffer. In networked application, the error flag will be readable by the network.

##### **COOLING SAT FAILURE**

In Cooling mode and all stages of compression are energized, the SAT must drive below the Supply Air Alarm Setpoint for Cooling within ten minutes or this SAT failure error will be activated. The error will be written to the Error History Buffer. In networked application, the error flag will be readable by the network.

#### **SUPPLY FAN FAILURE**

The conditions under which this failure is declared, and the follow-up actions of the control when this error occurs are described in a paragraph on Air Proving Switch Operation earlier in this document. The error will be written to the Error History Buffer. In networked application, the error flag will be readable by the network.

#### **COMPRESSOR SAFETY CHAIN TRIP**

The conditions under which this failure is declared, and the follow-up actions of the control when this error occurs are described in a paragraph on Compressor Status Monitoring earlier in this document. The error will be written to the Error History Buffer. In networked application, the error flag will be readable by the network.

#### **DIRTY FILTER ALARM**

The conditions under which this failure is declared, and the follow-up actions of the control when this error occurs are described in a paragraph on Dirty Filter Switch (DFS) option earlier in this document. The error will be written to the Error History Buffer. In networked application, the error flag will be readable by the network.

#### **HIGH DUCT STATIC ALARM**

The conditions under which this failure is declared, and the follow-up actions of the control when this error occurs are described in a paragraph on Duct Static High Limit Setpoint option earlier in this document. The error will be written to the Error History Buffer. In networked application, the error flag will be readable by the network.

#### **HOT WATER COIL FREEZE ALARM**

The conditions under which this failure is declared, and the follow-up actions of the control when this error occurs are described in a paragraph on FSI (Hot Water Freeze Protection) option earlier in this document. The error will be written to the Error History Buffer. In networked application, the error flag will be readable by the network.





