

**VARIABLE FREQUENCY DRIVE FOR INDOOR BLOWER
MOTORS 25-40 TON UNITS - Models *12, *13, and *14**

DESCRIPTION

This option is designed to provide variable air volume (VAV) without the use of inlet guide vanes (IGV). The option functions by using a variable frequency drive (VFD) to control the speed of the indoor blower motor based on the static pressure in the discharge duct.

The option includes a factory mounted pressure transducer and either a 7.5, 10, 15, 20 or 25 Hp variable frequency drive. The variable frequency drive is located in the blower section on a sheet metal mounting plate (See Fig. 1). For standard controls, the pressure transducer is located on that plate, but is located in the control box on Synthesys™ digital control units.

Specific motors require a specific variable frequency drive depending on the horsepower and voltage rating of the motor. The 7.5, 10, 15, 20 and 25 Hp motors require three-phase input power and the VFD produces three-phase output power to the indoor blower motor.

SEQUENCE OF OPERATION

A call for blower motor comes from the time clock relay that signals the unit to begin its day mode operation. When this call comes in, and as long as the air temperature remains below the adjustable set point of MWUP (Morning Warm-UP), relays FR1 and FR2 are engaged. FR1 and FR2 close to put the VFD in the "run mode". Contact FR-1 closes to engage unit heat (optional) at full capacity. Contact FR1-3 closes and FR1-2 opens to replace the SETRA pressure transducer to a 24 VAC signal, thus forcing the VFD to operate the motor at full RPM. Contact FR2 makes contact between terminals D1 and D2 to signal all VAV boxes to fully open.

When the return air reaches MWUP conditions, heating is then locked out, and relays FR1 and FR2 are disengaged. Contact FR1-2 opens and FR1-2 closes to restore control to the SETRA pressure transducer. Once powered the SETRA transducer controls the variable frequency drive via a 0-10VDC signal.

The VFD is configured to react inversely with the duct pressure. As the pressure in the duct rises past the duct static set point (1.5" WC) the fan volume decreases. As the duct pressure falls below the set point the fan volume increases. In heating mode, the FR1-2 contact will open and the FR1-3 contact will close, sending a 24 VAC signal to VFD, forcing the fan to run at full volume.

TABLE 1 - APPLICATION DATA

VFD MODEL NO.	HORSEPOWER	VOLTAGE
GPD506V-A027	7.5	208
GPD506V-A027	7.5	230
GPD506V-B014	7.5	380-60/50
GPD506V-B011	7.5	460
GPD515C-C010	7.5	600
GPD506V-A027	10.0	208
GPD506V-A027	10.0	230
GPD506V-B021	10.0	380-60/50
GPD506V-B014	10.0	460
GPD515C-C010	10.0	600
GPD506V-A054	15.0	208
GPD506V-A036	15.0	230
GPD506V-B027	15.0	380-60/50
GPD506V-B021	15.0	460
GPD515C-C017	15.0	600
GPD506V-A054	20.0	208
GPD506V-A054	20.0	230
GPC506V-B034	20.0	380-60/50
GPD506V-B027	20.0	460
GPD515C-C022	20.0	600
GPD506V-A068	25.0	208
GPD506V-A068	25.0	230
GPD506V-B034	25.0	380-60/50
GPD506V-B034	25.0	460
GPD515C-C022	25.0	600

**NOTE: THIS DOCUMENT IS A SUPPLEMENT TO THE
INSTALLATION INSTRUCTIONS.**

TABLE 2 - TROUBLE SHOOTING GUIDE

PROBLEM	POSSIBLE CAUSE/SOLUTION
1) Supply volume is low 2) Variable frequency drive is operating at 10Hz with low duct static pressure	1. Check pressure transducer tubing connections at the ambient and duct locations, verify location of high and low pressure static tubes 2. Check power to the P352P controller at the 24VDC and COM terminals. 3. Check connection from the P352P controller to the variable frequency drive. 4. Check the voltage out from the transducer "OUT". Voltage should be 0-5VDC, with the minimum above 1VDC.
3) Blower operates in reverse direction	1. Verify proper wiring to the drive. 2. Verify the Reverse run setting is correct. See GPD 506 technical manual for details.
4) Blower motor does not run.	1. Check power to the drive. 2. Power leads may be reversed. Wires 119, 120, 121 should connect to T1/U, T2/V, and T3/W. Wires 138, 139, and 140 should connect to L1/R, L2/S and L3/T.

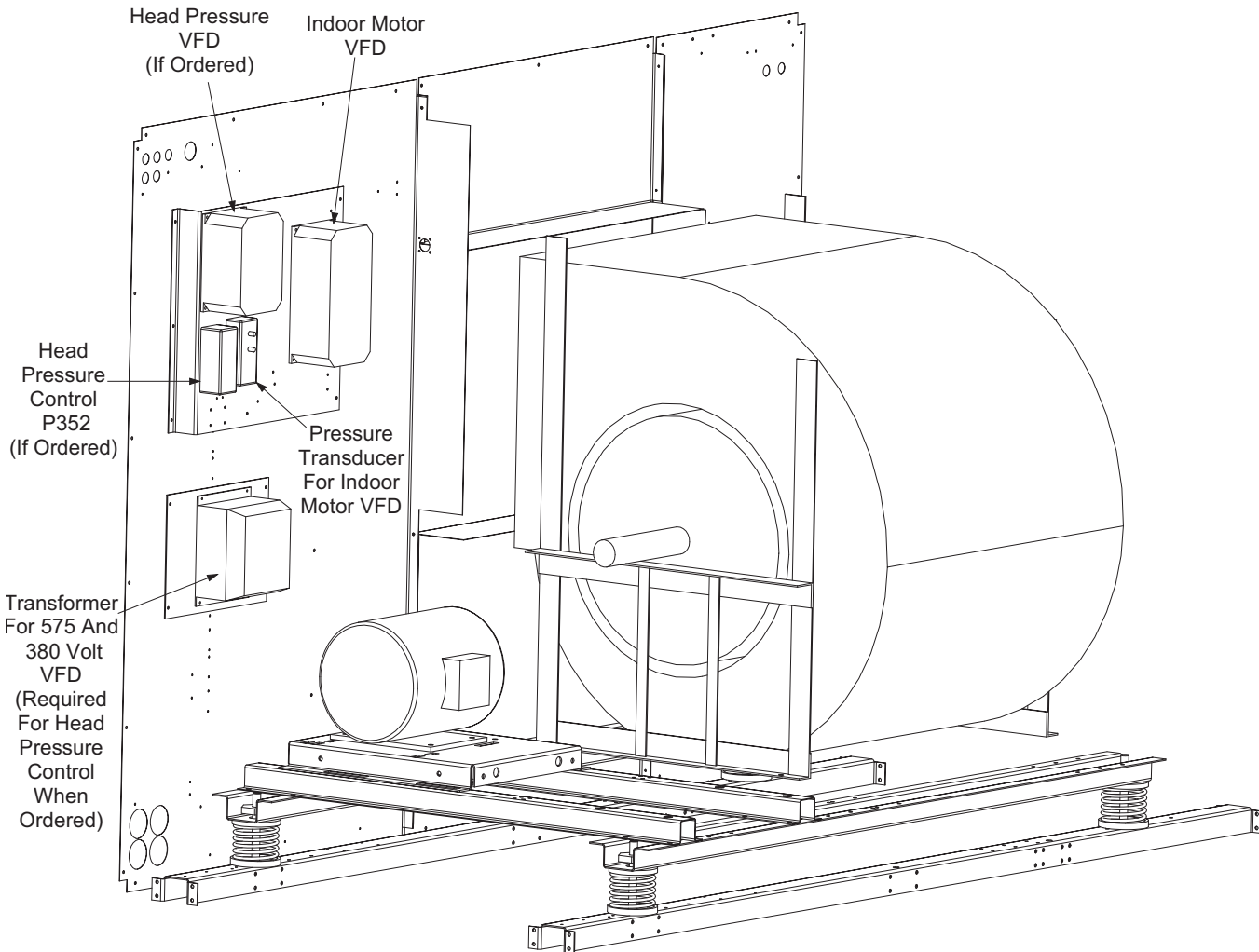

FIG. 1 - BLOWER SECTION CROSS SECTION

P352PPI CONTROLLER

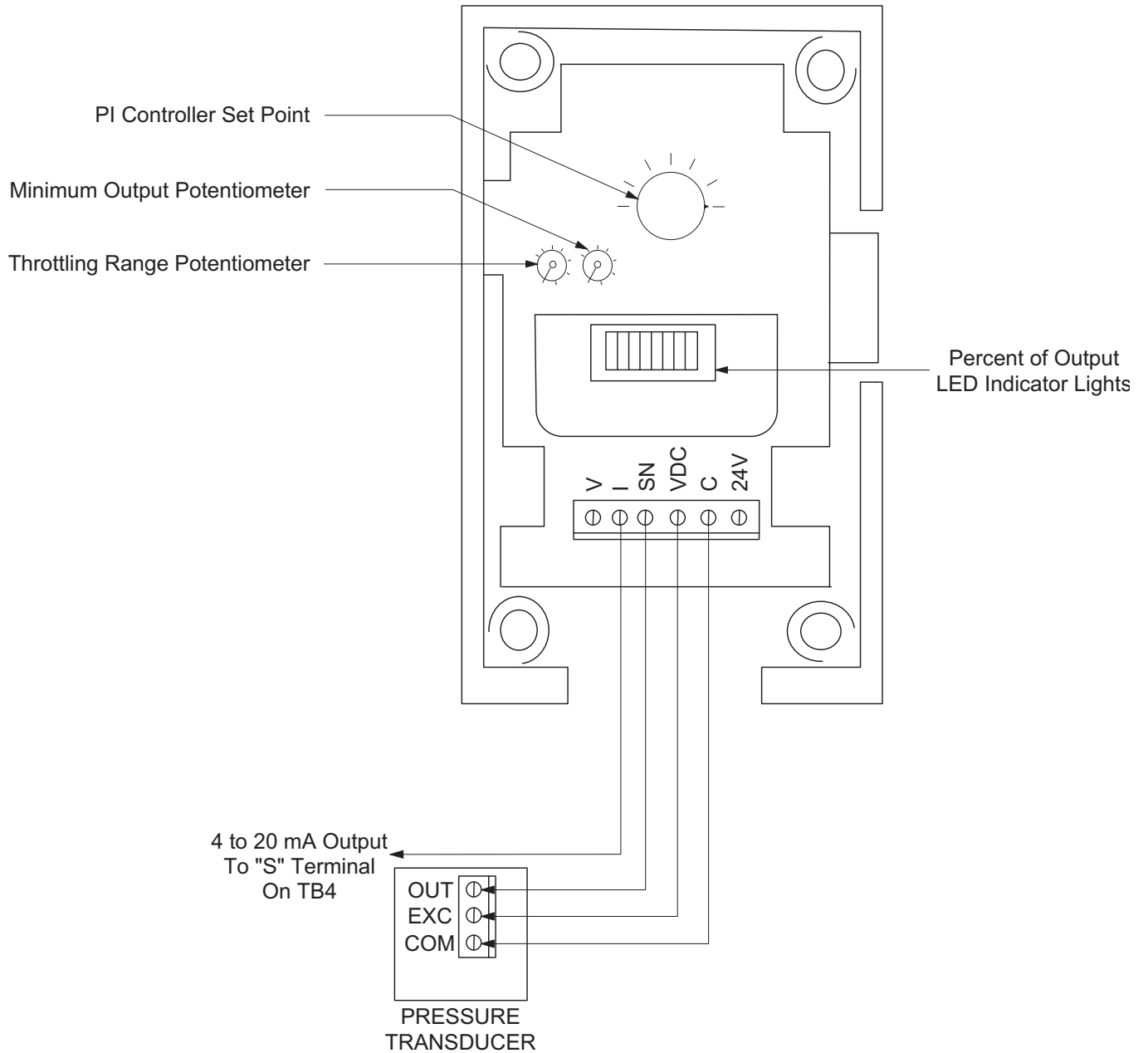

FIG. 2 - P352P PRESSURE CONTROL

