

VFD66 Series Condenser Fan Speed Controls

The VFD66 Series Condenser Fan Speed Controls regulate the speed of 3-phase condenser fan motors in refrigeration and Heating, Ventilating, and Air Conditioning (HVAC) systems by varying the frequency and voltage of the power supplied to the motor.

The VFD66 control accepts an input signal from the P35 Pressure Transducer, P399 Electronic Pressure Transducer, System 350™ pressure or temperature controls, or any other device that provides a 0-5 VDC or 0-10 VDC analog output signal.

The application-specific design of the VFD66 control provides a simple interface, which makes the control easy to understand and operate.

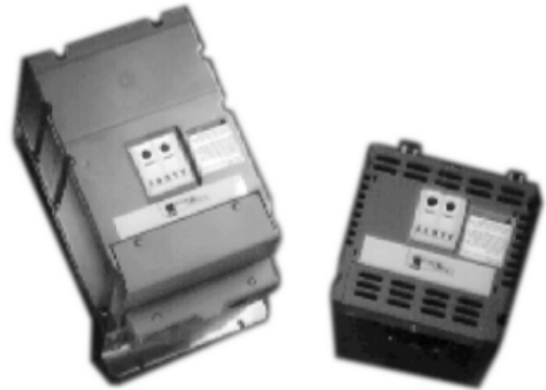

Figure 1: VFD66 Condenser Fan Speed Control, NEMA 4 and NEMA 1 Enclosures

Features and Benefits	
<input type="checkbox"/> Isolated Input Circuitry	Permits application with 0-5 VDC or 0-10 VDC controllers, sensors, transducers, and Johnson Controls System 350 controls
<input type="checkbox"/> Simultaneous Acceptance of Two Similar Inputs	Allows use on dual refrigeration circuits cooled by a single fan
<input type="checkbox"/> Compact Design	Provides installation ease and flexibility
<input type="checkbox"/> Three-Phase, 208/230, or 400/460 VAC Models	Handle three-phase motors ranging up to 10.6 amperes at 208/230 VAC or 5.5 amperes at 400/460 VAC
<input type="checkbox"/> Few End-User Settings	Provide fast and easy installation and setup

Application

IMPORTANT: The VFD66 Series Condenser Fan Speed Controls are intended to control equipment under normal operating conditions. Where failure or malfunction of a VFD66 control could lead to an abnormal operating condition that could cause personal injury or damage to the equipment or other property, other devices, (limit or safety controls) or systems (alarm or supervisory) intended to warn of, or protect against, failure or malfunction of the VFD66 control must be incorporated into and maintained as part of the control system.

The VFD66 control accepts input signals from a variety of pressure transducers, temperature sensors, and low-voltage controllers to provide continuous response to changing condenser load conditions.

The VFD66 control allows the system to:

- maintain optimum condenser head pressure in low ambient temperature conditions
- eliminate short-cycling in low ambient temperatures or changing load conditions
- match the condenser fan speed to the load on the condenser, which increases the efficiency of the refrigeration system. This can reduce electricity cost and help maintain a constant evaporator temperature.

The VFD66 control also:

- stabilizes the condenser head pressures, which helps optimize compressor operation and can reduce wear and extend compressor life
- eliminates the condenser fan short-cycling, which can reduce motor repair and replacement costs
- stabilizes evaporator temperatures, which can extend refrigerated product life and provide more consistent comfort cooling

Installation

Use the information in this section to install the VFD66 control.

Dimensions

Figure 2, Figure 3, and Figure 4 show dimensions of the enclosures used on the VFD66 controls. See Figure 2 for information on models with NEMA 1 enclosures. See Table 1, Figure 3, and Figure 4 for information on models with NEMA 4 enclosures.

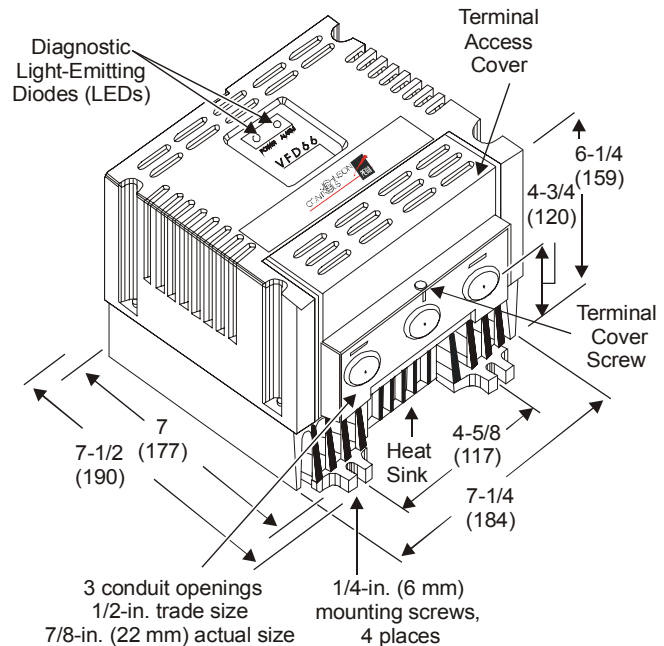

Figure 2: VFD66 NEMA 1 Enclosure Dimensions

Table 1: NEMA 4 Enclosure Size by Types/Models

NEMA 4 Enclosure Size	Models
Small	VFD66AEE, VFD66BEE
Large	VFD66CEE, VFD66DEE

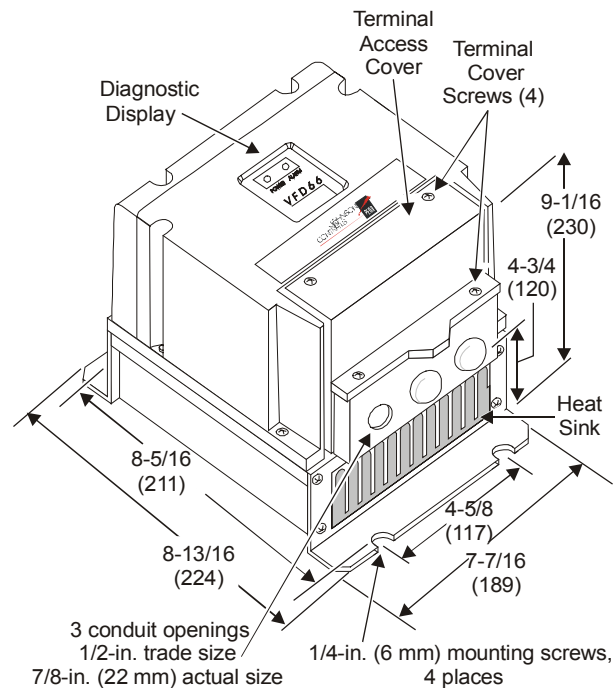

Figure 3: Small VFD66 NEMA 4 Enclosure Dimensions

Accessories

Table 2 lists input devices and other accessories used with the VFD66 controls, available from Johnson Controls/PENN.

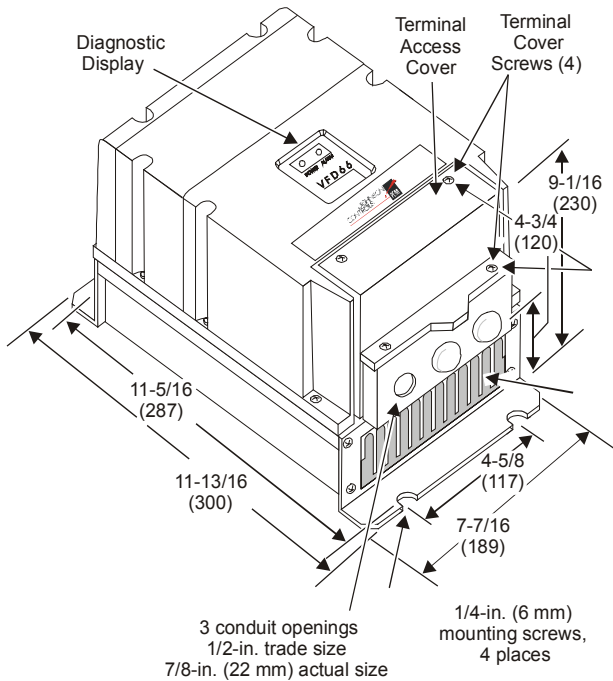

Figure 4: Large VFD66 NEMA 4 Enclosure Dimensions

Table 2: Pressure Transducers, Temperature Controls, and Other Accessories for VFD66 Series Controls

Product Code Number	Description	Information
P35AG-9200R	Pressure Transducer 0-350 psi range	Refer to <i>P35 Pressure Transducer and VFD66 Control Application Note (LIT-121418)</i> for more information.
P399AAA-1C P399AAC-1C	Electronic Pressure Transducer, 0-100 psi range	Refer to <i>P399 Series Electronic Pressure Transducers Product/Technical Bulletin (LIT-125515)</i> for more information.
P399GAA-1C	Electronic Pressure Transducer, 0-200 psi range	
P399BAA-1C P399BAC-1C	Electronic Pressure Transducer, 0-500 psi range	
P399CAA-1C P399CAC-1C	Electronic Pressure Transducer, 0-750 psi range	
P399AAA-1-200C P399AAC-1-200C	Electronic Pressure Transducer (as above) packaged with WHA-P399-200C	
P399BAA-1-200C P399BAC-1-200C		
P399CAA-1-200C P399CAC-1-200C		
WHA-P399-200C		
WHA-P399-400C	Wire Harness with pigtail leads, 13 ft (4 m)	
WHA-P399-600C	Wire Harness with pigtail leads, 19-5/8 ft (6 m)	
Continued on next page . . .		

Product Code Number (Cont.)	Description	Information
A350PS-1C	Proportional Plus Integral Temperature Control	Refer to <i>System 350 A350P Electronic Proportional Plus Integral Temperature Control Product/Technical Bulletin (LIT-930020)</i> for more information.
P352PN-3C	Proportional Plus Integral Pressure Control	Refer to <i>System 350 P352PN Electronic Proportional Plus Integral Pressure Controls for PSI Applications Product/Technical Bulletin (LIT-930044)</i> for more information.
VFD66-CVR-1C	External Potentiometer Replacement Cover	Refer to <i>Installing the External Potentiometer Replacement Cover Application Note (LIT-121419)</i> for more information.

Mounting



CAUTION: Risk of Thermal Damage.

The VFD66 control can generate and dissipate significant heat. Mount the control on a metal, concrete, or cinderblock mounting surface. Mounting the VFD66 control on surfaces made of wood or other heat-sensitive material may result in damage to the mounting surface.



WARNING: Risk of Electrical Shock.

The VFD66 controls remain electrically charged for a period of time after power is removed. To avoid possible electrical shock, wait at least 5 minutes after AC supply power has been disconnected from the VFD66 controls before servicing the control.

Failure to wait until the VFD66 control fully discharges could cause electrical shock, personal injury, or death.

Follow the guidelines below when mounting a VFD66 control:

- Mount the VFD66 control on a vertical surface with the heat sink fins oriented vertically and the conduit holes facing down.
- Provide a minimum of 4 in. (102 mm) clearance around the heat sink.
- Ensure that output power wiring between the VFD66 control and the motor does not exceed 50 ft (15 m).
- Mount NEMA 1 models indoors, in a location protected from explosive vapors, corrosive gas, water, and dust.
- Mount NEMA 4 models indoors or outdoors in a location protected from explosive vapors, corrosive gas, and dust, and out of direct sunlight.

Ambient air temperature and installation altitude affect the maximum output rating of the VFD66 controls (see *De-Rating the VFD66 Control for High Temperatures and High Altitudes*).

Wiring



WARNING: Risk of Electrical Shock.

The printed wiring board and its components are at AC line voltage. **Direct or indirect contact with line voltage can result in personal injury or death.**



CAUTION: Risk of Equipment Damage.

Connect each of these items to the VFD66 controls, using a separate conduit for each set of wires:

- Line Voltage Supply Power
- Line Voltage Output Power to Fan Motor
- Low Voltage Signals from Input Devices

Running different voltage and frequency wires in the same conduit can create electronic noise or harmonics, which may damage the condenser fan motors.

Read this entire section, including the information on emissions compliance, before wiring the VFD66 control. See Figure 5 for a view of the circuit board components and the conduit entry bracket.

Accessing the Interior

Remove the terminal access cover (see Figure 2, Figure 3, and Figure 4) to access terminal blocks, jumper blocks, and internal potentiometers (see Figure 5).

NEMA 1 Enclosure

Follow these steps to remove the terminal access cover:

1. Remove the terminal cover screw.
2. Push downward on the ventilation holes.
3. Pull outward on the top of the terminal access cover.

NEMA 4 Enclosure

Follow these steps to remove the terminal access cover:

1. Remove the four terminal cover screws.
2. Grasp the rubber tab at the bottom of the terminal access cover.
3. Pull the tab outward and upward to remove the terminal access cover.

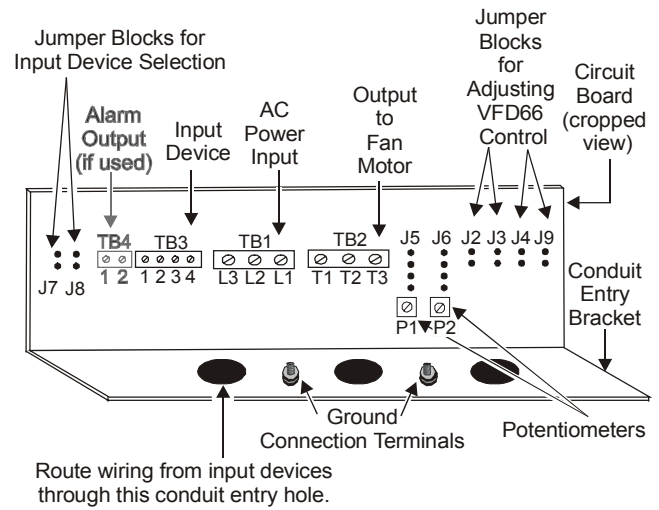

Figure 5: Jumper Block, Terminal Block, and Potentiometer Locations

Table 3: Terminal Blocks

Terminal Block Label	Terminal Block Function	Electrical Rating	Terminal	Terminal Function
TB1	Input Line Voltage Power	See <i>Technical Specifications</i> .	L1	Line 1 Input
			L2	Line 2 Input
			L3	Line 3 Input
TB2	Output Line Voltage Power to Fan Motor		T1	Line 1 Output
			T2	Line 2 Output
			T3	Line 3 Output
TB3	Low-voltage Input Signals, 0-5 VDC Power Supply	0-5 VDC or 0-10 VDC	1	5 VDC power supply
			2	First signal input
			3	Second signal input*
			4	Common
TB4	Alarm Output for User-Installed Alarm Device	100 mA at 24 VAC/30 VDC	1	Switch contact
			2	Switch contact

* See *Adjusting the Control Settings*.

Wiring an Input Device

Connect a low-voltage input signal device to Terminal Block TB3 (see Table 3 and Figure 5). See Table 4, Figure 6, Figure 7, and Figure 8 for information on wiring specific Johnson Controls/PENN™ input devices to the VFD66 controls.

Table 4: Wiring Johnson Controls/PENN Input Devices

Input Device	Input Device Terminal	VFD66 Control TB3 Terminal
P35AG-9200R Transducer	1	1
	2	2 (or 3)*
	3	4
A350PS-1C or P352PN Series Controls	V	2 (or 3)*
	C	4
P399 Series Transducers	Red	1
	White	2 (or 3)*
	Black	4

* Use Terminal 3 for input from a second input device.

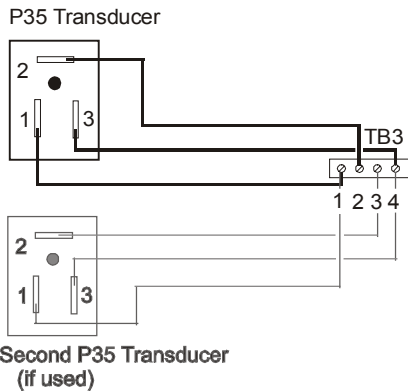

Figure 6: Wiring P35 Transducers to VFD66 Terminal Block 3

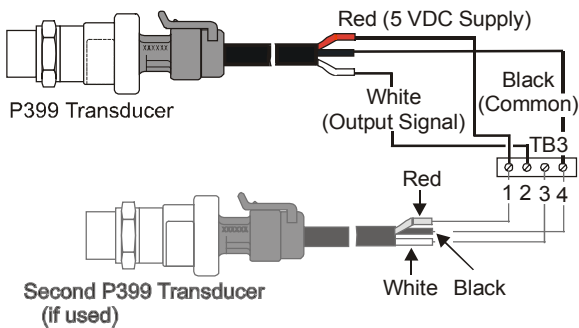

Figure 7: Wiring P399 Transducers to VFD66 Terminal Block 3

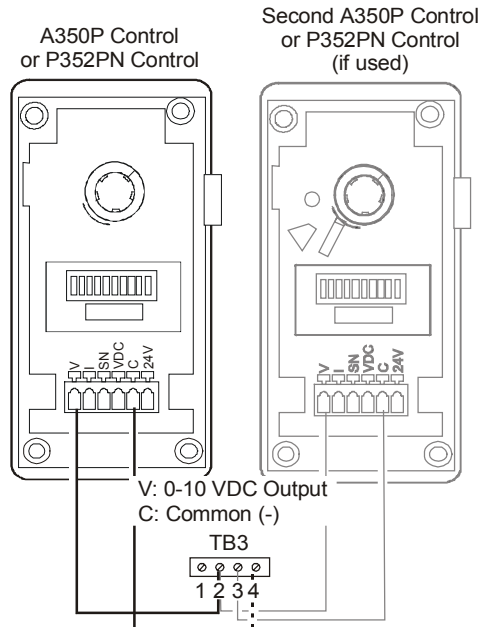

Figure 8: Wiring A350P Controls or P352PN Controls to VFD66 Terminal Block 3

Wiring an External Alarm to the VFD66 Control

Some models of the VFD66 controls feature an alarm output. The Metal Oxide Silicon Field Effect Transistor (MOSFET) alarm output activates when a permanent fault condition occurs. See Table 14, Figure 5, and Figure 9.

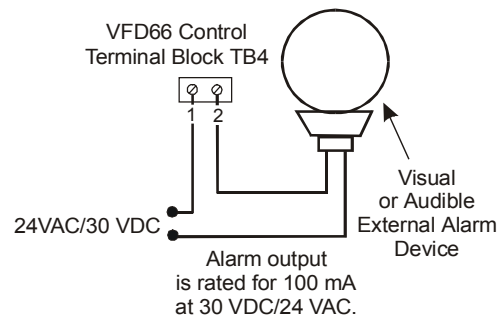

Figure 9: Wiring the Alarm Output

Wiring Power

Select wire size for field wiring based on a wire insulation temperature resistance rating of 167°F (75°C), with a maximum wire size of 12 AWG. Use only stranded copper wire, rated for at least 600 volts. Maximum terminal tightening torque for all VFD66 controls electrical terminals is 5 lb-in (0.565 N·m).

Ensure that the motor(s) and VFD66 control are securely and adequately grounded. Use the two ground connection terminals on the conduit entry bracket. (See Figure 5.) Use a ground connection terminal similar to AMP Part Number 34162 for 16-14 AWG wire size or AMP Part Number 322455 for 12-10 AWG wire size.

Wiring Input Power

CAUTION: Risk of Equipment Damage.
Wiring line-voltage input power to the wrong terminal block will damage the VFD66 control. Wire input power ONLY to Terminal Block 1 (TB1).

CAUTION: Risk of Equipment Damage.
Use of an incorrect power source may cause equipment damage. Ensure that the power source conforms to the requirements of the equipment.

The input line-voltage supply power to L1, L2, and L3 (Terminal Block 1) must be fused. Use fuses sized for 250% of the input current rating of the VFD66 control. For example, if a VDF66 control is rated at 4 amperes input current, use a 10-ampere fuse. Do not use fuses with an extremely fast-opening characteristic (rectifier fuses).

Wiring Output Power

IMPORTANT: The output phase rotation on TB2 at T1(U), T2(V), T3(W) is ABC. If the motor rotation is incorrect, interchange any two motor leads on TB2. Do not make changes to the input power supply wiring.

The length of output power wires between the VFD66 control (TB2) and the motor must not exceed 50 ft (15 m).

Emissions Compliance

If the VFD66 control is used in commercial or residential applications, FCC and DOC compliance may require the addition of the items in Table 5 to reduce electronic noise emissions. Installation of the parts listed in Table 5 is required for EU Directive Compliance (CE mark):

- 72/23/EEC (Low Voltage Directive)
- 89/336/EEC (EMC Directive)

Table 5: Emissions Compliance

Required Item		Suggested Model
EMI Filter for VFD Types:	Axx, Bxx, Dxx, and Fxx	Schaffner® EMV AG FN 258-7/29*
	Cxx and Exx	Schaffner EMV AG FN 258-16/29
Ferrite Core (Two Required)		Fair-Rite® No. 04431672451
Shielded Power Wiring		Any 3-conductor, braided, shielded cable

* Contact Schaffner and Fair-Rite for local distributors.

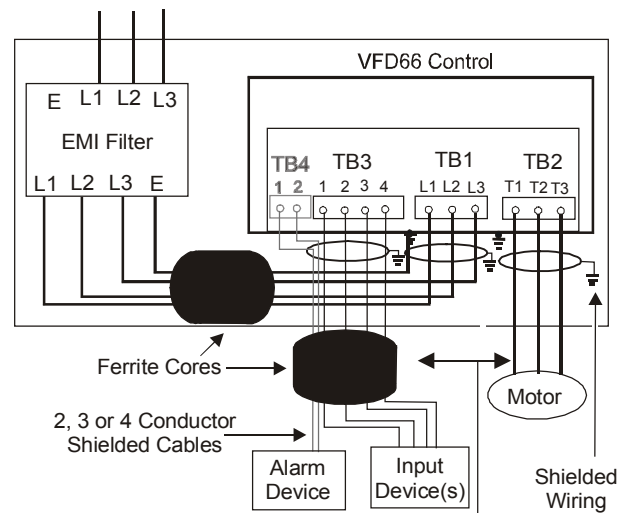

Separate input and output cables. Do not run input cables alongside output cables. Do not bundle input and output cables together.

Figure 10: CE/FCC/DOC Compliance Wiring

Setup and Adjustments

This section describes how to set up the VFD66 control. Remove the terminal access cover to access the jumper blocks and internal potentiometers. See *Accessing the Interior*.

Adjusting the Control Settings

WARNING: Risk of Electrical Shock.
The printed wiring board and its components are at AC line voltage. Disconnect power from the control before making any adjustments. Do not touch any tool to any part of the wiring board while power is applied. **Failure to follow these precautions can result in personal injury or death.**

Control settings are established by positioning six jumpers and adjusting two potentiometers.

Factory default settings have all the jumpers in the installed position and the potentiometers set fully clockwise. (See Table 6, Figure 5 and Figure 11.)

Table 6: Jumper Settings by Function

Jumper Block	Function	Jumper Removed*	Jumper Installed
J2	Mode of Operation	See <i>Selecting an Input Mode</i> .	
J3			
J4	Acceleration/Deceleration Time	5 Seconds	30 Seconds
J5	Internal/External P1	Do not move the jumpers from the factory-installed position unless installing the External Potentiometer Replacement Cover.	
J6	Internal/External P2		
J7	Input Signal Type	0-10 VDC	0-5 VDC
J8	Number of Input Signals Used	Dual	Single
J9	Maximum Output Frequency	50 Hz	60 Hz

* Do not discard jumpers. (See Figure 11.)

To place a jumper in the removed position, reposition the jumper so that it is connected to only one pin on the jumper block. Keep the jumper because it may be needed in the future. To place a jumper in the installed position, place the jumper on both pins. (See Figure 11.)

Jumper blocks J2 and J3 establish input modes and work in conjunction with potentiometers P1 and P2. See *Selecting an Input Mode*.

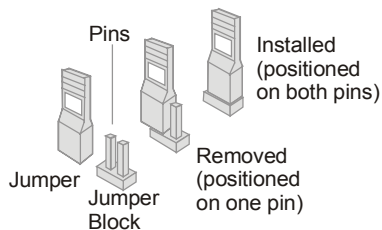

Figure 11: Jumper Placement on Pins

Jumper blocks J5 and J6 have jumpers installed on the two middle pins of each jumper block. These jumpers activate the internal potentiometers. Moving the jumpers from the factory-installed position disables the internal potentiometers.

Jumpers on J7 and J8 must be set for the correct input voltage range and number of input devices. (See Table 6.) Jumper block J7 sets the voltage range for the input signal(s). If the jumper on jumper block J7 is incorrectly set, the control may operate in an unexpected manner. See *Troubleshooting*.

Jumper block J8 selects the number of input signals used. When dual inputs are selected, Terminal 3 of TB3 (TB3-3) is enabled. The VFD66 control varies the speed of the fan motor in accordance with the higher value of the two input signals received. If the jumper on jumper block J8 is incorrectly set, the control may operate in an unexpected manner. See *Troubleshooting*.

Jumper block J9 selects maximum frequency output of the control. Remove the jumper for 50 Hz motors, typically used in Europe. Install the jumper for 60 Hz motors, typically used in North America. Power to the VFD66 control must be disconnected and reconnected before frequency changes take effect.

De-Rating the VFD66 Control for High Temperatures and High Altitudes

Ambient air temperature and altitude of the installation affect the maximum output ampere rating of the VFD66 control. High air temperature makes the heat sink less effective in dissipating the generated heat. High altitudes have thinner air than lower altitudes, which is less effective in dissipating heat. The less effective the heat sink is, the lower the maximum output ampere rating of the VFD66 control.

Temperature De-Rating

For temperatures up to 122°F (50°C), the maximum output ampere rating is unaffected by temperature. At temperatures between 122°F (50°C) and 140°F (60°C), the maximum output ampere rating is decreased. The VFD66 controls are not designed to operate in temperatures above 140°F (60°C).

See Figure 12 for temperature de-rating for 208/230 VAC models. See Figure 13 for temperature de-rating for 400/460 VAC models.

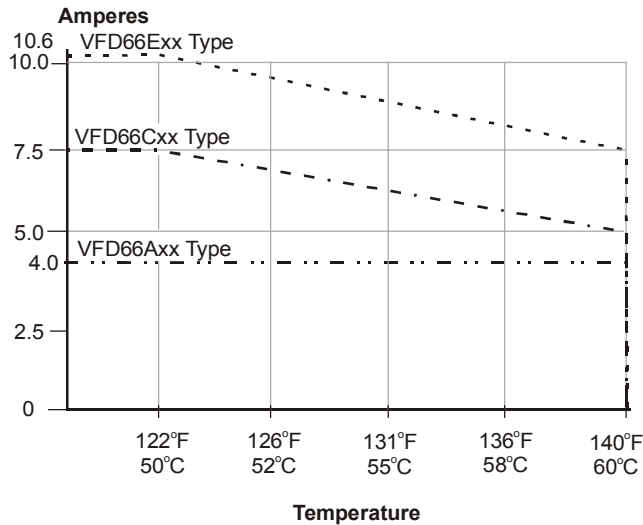

Figure 12: 208/230 VAC Temperature De-Rating

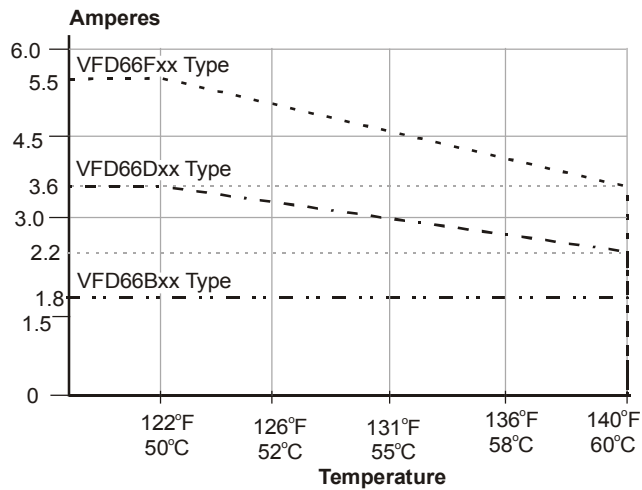

Figure 13: 400/460 VAC Temperature De-Rating

Altitude De-Rating

See Table 7 for altitude multipliers. Use the following formula to determine the adjusted rating:

$$\begin{matrix} \text{Temperature} \\ \text{De-Rated} \\ \text{Maximum} \\ \text{Output} \\ \text{Amperes} \end{matrix} \times \begin{matrix} \text{Altitude} \\ \text{Multiplier} \end{matrix} = \begin{matrix} \text{De-Rated} \\ \text{Maximum} \\ \text{Output} \\ \text{Amperes} \end{matrix}$$

Table 7: Altitude Multipliers for De-Rating

Altitude Range	Altitude Multiplier
0-3300 ft (0-1000 m)	1.0
3300-4300 ft (1000-1305 m)	0.97
4300-5300 ft (1305-1610 m)	0.94
5300-6300 ft (1610-1915 m)	0.91
6300-7300 ft (1915-2220 m)	0.88
7300-8300 ft (2220-2525 m)	0.86
8300-9300 ft (2525-2830 m)	0.83
9300-10300 ft (2830-3135 m)	0.80
10300-11300 ft (3135-3440 m)	0.78

De-Rating Examples

For these examples, the control used is a VFD66Exx type. See Figure 12, Figure 13, and Table 7.

- If a VFD66Exx type (208/230 VAC) is used and the temperature is below 122°F (50°C), the VFD66 control may be used for loads up to 10.6 amperes at any altitude below 3300 ft (1000 m).
- If the temperature around the VFD66 control reaches 140°F (60°C), the rating is different. According to Figure 12, the VFD66 control is rated for only 7.5 amperes at 140°F (60°C).
- If the VFD66 control is used in Denver, Colorado (altitude 5200 ft), the output rating is reduced. (See Table 7.) When the temperature is less than 122°F (50°C), the VFD66 control is rated for 9.96 amperes, as shown by the equation:

$$\text{De-Rated Maximum Output Amperes} = 10.6 \text{ Amperes} \times 0.94 = 9.96 \text{ Amperes}$$

- If the VFD66 control is used in Denver, Colorado (altitude 5200 ft), and the ambient temperature reaches 140°F (60°C), then the VFD66 control is de-rated to a 7.5-ampere maximum current draw due to the high ambient temperature and is further de-rated to 7.05 amperes of current draw because of high altitude.

$$\text{De-rated Maximum Output Amperes} = 7.5 \text{ Amperes} \times 0.94 = 7.05 \text{ Amperes}$$

Commissioning

Table 8: Mode Selections According to Input Device

Input Device	Input Type	Input Mode	J2 Jumper Position	J3 Jumper Position	J7 Jumper Position ²
Any ¹	None ¹	Manual	Installed	Installed	NA
A350P	Temperature	Standard	Installed	Removed	Removed
P352PN	Pressure	Standard	Installed	Removed	Removed
P35AG-9200	Pressure	Standard	Installed	Removed	Installed
Any 0-5 VDC Devices	Any ³	Standard	Installed	Removed	Installed
Any 0-10 VDC Devices	Any ³	Standard	Installed	Removed	Removed
P399 or Other Electronic Pressure Transducer	Pressure	Electronic Pressure Transducer	Removed	Removed or Installed ⁴	Removed or Installed ⁴

1. Setting the mode to manual ignores the input devices.
2. Position of jumper on J7 depends on the input device used.
3. Input type varies with device.
4. Transducer may provide 0-5 VDC or 0-10 VDC signal. A 0-10 VDC transducer must be separately powered. Note that a non-ratiometric transducer will have more error.

Selecting an Input Mode

See Table 8 for the available input mode options for the VFD66 control. The factory-set mode is Manual Input mode.

Manual Input Mode

Manual Input mode allows the user to set a constant motor speed. This can be used where manual control is desired or while repairing input signal devices or obtaining replacements. In Manual Input mode, the input device signals are disregarded. Motor speed is controlled by adjusting the P1 potentiometer. Potentiometer P2 is disregarded and adjusting P2 has no effect.

Table 9: Manual Input Mode

J2 Jumper Position	J3 Jumper Position	P1: Motor Speed	P2: Not Used
Installed	Installed	Adjusts constant speed of motor (0-100%)	—

Standard Input Mode

Standard Input mode is the most commonly used mode. The majority of input devices compatible with the VFD66 controls are used with this mode. The input device determines the setpoint and proportional band.

Table 10: Standard Input Mode

J2 Jumper Position	J3 Jumper Position	P1: Minimum Motor Speed	P2: Motor Action at Minimum Speed
Installed	Removed	Can be set at 0-50% of maximum motor speed.	CCW: Motor idles. CW: Motor shuts off.

P1 adjusts the minimum speed of the motor. The minimum speed is adjustable from 0 to 50% of total motor speed.

P2 determines whether the motor idles at minimum speed or shuts off at minimum speed. P2 must be set at full Counterclockwise (CCW) or full Clockwise (CW) position; intermediate settings have no effect.

Figure 14 illustrates three possible motor speed curves. When P2 is rotated fully CCW, the motor idles at the minimum speed set by P1 at input values below the end of the proportional band (Curve A in Figure 14). When P2 is rotated fully CW, the motor shuts off at the minimum speed set by P1 when the input is below the bottom end of the proportional band (Curve B in Figure 14).

In Curve C, the minimum motor speed (P1) is set at 0% of maximum motor speed and the position of P2 has no effect.

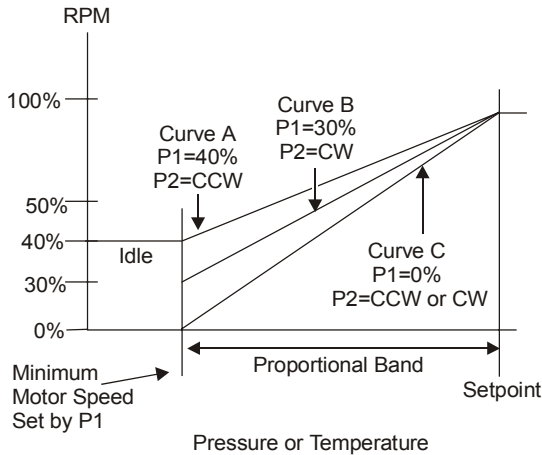

Figure 14: Standard Input Mode

Electronic Pressure Transducer Input Mode

IMPORTANT: Minimum motor speed and motor action at minimum speed cannot be set in this mode.

The VFD66 controls work with any electronic pressure transducer that generates a 0-5 VDC or 0-10 VDC output signal. For best results, use the P399 Electronic Pressure Transducer or another ratiometric transducer. A ratiometric transducer varies the signal voltage from 10-90% of the 5 VDC supply power as the pressure goes from minimum to maximum of the transducer rating.

J3 establishes the low or high pressure range of P1. See Table 11.

J7 establishes the voltage range of the transducer. The J7 jumper must be installed when using a P399 pressure transducer or another 0-5 VDC electronic pressure transducer. The J7 jumper must be removed when using 0-10 VDC electronic pressure transducers.

P1 adjusts the pressure setpoint and establishes the pressure value at which the VFD66 controls drive the fan motor at maximum speed.

P2 adjusts the proportional band over which fan motor speed is controlled.

Figure 15 illustrates J3, P1, and P2 settings in Electronic Pressure Transducer Input mode with a P399 transducer (0-500 psi). If the jumper on J3 is in the removed position, P1 adjusts the setpoint between 200-350 psi. The fan motor starts when pressure reaches 200 psi (Setpoint – Proportional Band) and maximum motor speed (100% RPM) is reached at 250 psi (Setpoint).

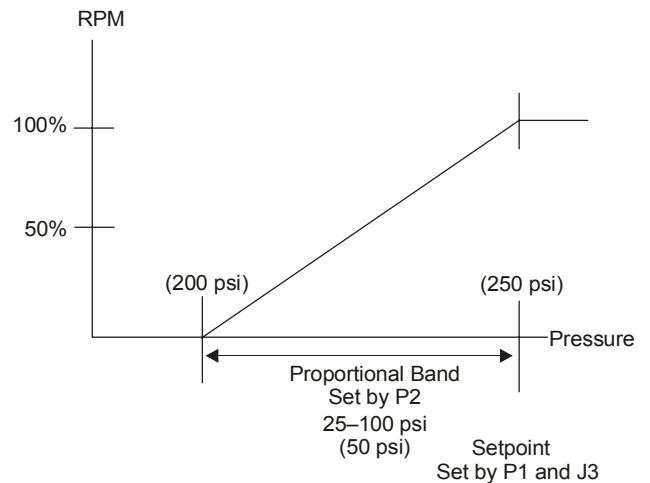

Figure 15: Electronic Pressure Transducer Input Mode, 0-500 psi P399 Transducer

Table 11: Electronic Pressure Transducer Input Mode

J2 Jumper Position	J3 Jumper Position	P1: Setpoint Range	P2: Proportional Band	Pressure Range	Electronic Pressure Transducer Model Numbers
Removed	Installed	16-44 psi	5-20 psi	0-100 psi	P399AAA-1C P399AAC-1C
Removed	Removed	40-70 psi			
Removed	Installed	32-88 psi	10-40 psi	0-200 psi	P399GAA-1C
Removed	Removed	80-140 psi			
Removed	Installed	80-220 psi	25-100 psi	0-500 psi	P399BAA-1C P399BAC-1C
Removed	Removed	200-350 psi			
Removed	Installed	120-330 psi	38-150 psi	0-750 psi	P399CAA-1C P399CAC-1C
Removed	Removed	300-525 psi			
Removed	Installed	16-44% of range	5-20% of range	Unknown	Other
Removed	Removed	40-70% of range			

Operation

The VFD66 controls feature two diagnostic LEDs: POWER and ALARM. (See Figure 16.)

The POWER LED illuminates when power is applied to the VFD66 controls. When power is disconnected from the VFD66 controls, this LED remains illuminated while the power supply capacitors discharge. If the motor is not running when power is removed, the LED may remain illuminated for up to 5 minutes, while the capacitors discharge.

The ALARM LED indicates fault conditions and provides diagnostic information. Constant illumination of this LED indicates that the motor is overloaded and the VFD66 control shuts down the motor.

When the ALARM LED flashes, the VFD66 control has shut down the motor. The number of times the ALARM LED flashes indicates the cause of the fault.

(See *Troubleshooting*.)

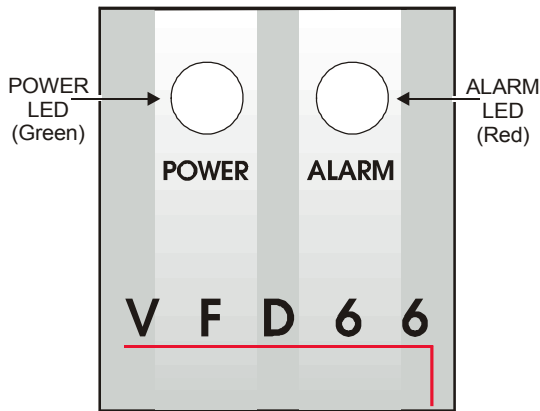

Figure 16: LED Display

Troubleshooting

If the VFD66 control provides reduced output voltage and frequency, see *Undervoltage Operation*. If the VFD66 control operates in another unexpected manner, see *Unexpected Operation*.

Undervoltage Operation

If the supply voltage drops below 60% of nominal, the VFD66 control stops the motor until the voltage returns to or rises above 60%.

If the supply voltage is between 60% and 100% of nominal, the VFD66 control adjusts the output voltage and frequency to avoid damaging the motor. The VFD66 control adjusts the output frequency to match the available input power. (See Figure 17 and Figure 18.)

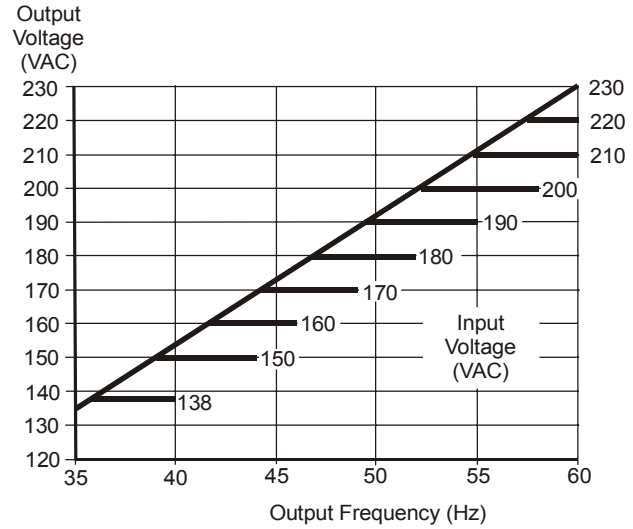

Figure 17: Output Voltage and Frequency vs. Input Power, 208/230 VAC

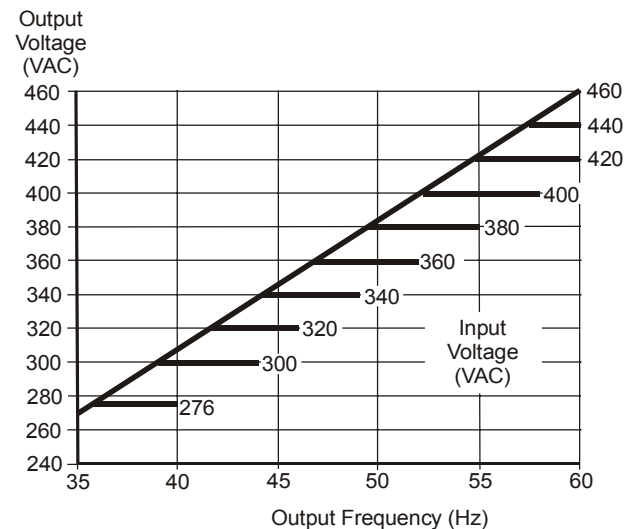

Figure 18: Output Voltage and Frequency vs. Input Power, 400/460 VAC

Examples

These examples use a VFD66 control rated for 400/460 VAC at 50/60 Hz. The control is used in North America, so the maximum supply voltage is 460 VAC at 60 Hz.

- If the supply voltage is 460 VAC (100% of 460 VAC), the VFD66 control runs the motor at full speed (460 VAC at 60 Hz).
- If the supply voltage drops to 368 VAC (80% of 460 VAC), the VFD66 control can only provide 368 VAC and the control reduces the output frequency to 53 Hz.
- If the supply voltage drops to 276 VAC (60% of 460 VAC), the VFD66 control can only provide 276 VAC and the control reduces the output frequency to 40 Hz.
- If the supply voltage drops below 276 VAC (60% of 460 VAC), then the VFD66 control stops the motor and does not restart it until the supply voltage rises to at least 276 VAC.

Unexpected Operation

If the VFD66 control operates in an unexpected manner, check the settings on jumper blocks J7 and J8 (see Figure 5, Table 12, and Table 13).

Table 12: Jumper Block J7

If the control is set for...	and if the control receives...	The result is...
0-10 VDC (J7 jumper installed)	0-5 VDC	the VFD66 control only drives the motor at half of the full motor speed.
0-5 VDC (J7 jumper removed)	0-10 VDC	the VFD66 control only uses 0-5 VDC and the motor reaches full speed when the input signal is at 5 VDC.

Table 13: Jumper Block J8

If the control is set for...	And ___ input devices are used	The result is...
one input (J8 installed)	two	the second input device is ignored.
one input (J8 installed)	none	the VFD66 control runs the motor at full speed only.
two inputs (J8 removed)	one	the VFD66 control runs the motor at full speed.
two inputs (J8 removed)	none	the VFD66 control runs the motor at full speed only.

Shutdown

The ALARM LED indicates fault conditions and provides diagnostic information. Constant illumination of this LED indicates that the motor is overloaded and the VFD66 control shuts down the motor. When the ALARM LED flashes, the VFD66 control has shut down the motor. The number of times the ALARM LED flashes indicates the cause of the fault. See Table 14.

After shutdown, there is a 30-second time delay before the VFD66 control initiates an automatic restart. The result is one of the following:

- If the fault condition is corrected, the VFD66 control continues to operate. After 500 seconds, the fault routine resets automatically.
- If the fault persists, the VFD66 controls lock out again, requiring reset.

Table 14: Fault Conditions

Red LED Flashes	Condition	Definition	Possible Cause	Solution
1	Over Current	Fault trips if output current momentarily exceeds approximately 200% of output current rating.	Short in motor or leads	Check motor and wiring.
			VFD66 control is trying to accelerate load too quickly or load is too large.	Install jumper on J4 to slow acceleration/deceleration rate.
2	Over Voltage	Fault trips if voltage exceeds 123% of nominal.	Input voltage is too high.	Ensure that the input voltage matches the rating of the model of the VFD66 control.
			VFD66 control deceleration time is shorter than time needed to stop the load.	Install the jumper on J4 to slow acceleration/deceleration rate.
3	Motor Overload	Trips if output current is 110% for 1 minute.	Mechanical problems	Inspect for mechanical problems.
			Excessive motor current	If overload is continuous, VFD66 control and motor with higher ratings may be required. Check motor specifications.
			Motor winding failure	Disconnect motor from VFD66 control. Ensure that resistance of each motor winding is within 5% of each other. If motor windings are defective, replace motor.
4	not used			
5	Pulse Width Modulation Generator Fault	Trips on detection of abnormal microprocessor operation.	Internal fault	Shut off power. Wait 5 minutes. Reapply power. If problem persists, replace VFD66 control.
6	Logic Fault	Internal circuitry fault	Internal fault	Shut off power. Wait 5 minutes. Reapply power. If problem persists, replace VFD66 control.

To reset a locked-out VFD66 control, follow the procedure below:

1. Disconnect power from the VFD66 control.
2. Wait 5 minutes to allow the internal capacitors to fully discharge.
3. Reapply power to the VFD66 control.

Selecting a Motor

IMPORTANT: Do not exceed the VFD66 control's maximum output ampere rating. Exceeding the control's maximum output ampere rating can cause the VFD66 control to shut down on an overload fault.

The VFD66 control allows the motor to develop torque that varies with the current. The motor provides maximum torque at its maximum current draw. Use these guidelines to select the proper motor for use with the VFD66 control.



CAUTION: Risk of Equipment Damage.

Motors for use with the VFD66 controls must meet certain specifications for proper performance and operation. Motors that do not meet these specifications may be damaged.

Required Motor Specifications

Motors used with the VFD66 Series Controls must:

- have variable torque operation
- be UL Recognized and CSA Certified, or equivalent
- be AC induction 3-phase motors
- be rated for 208/230 VAC, 60 Hz (230 VAC, 50 Hz) or 460 VAC, 60 Hz (400 VAC, 50 Hz)
- have ball bearings
- have an Inverter Rating (400/460 VAC motors)
- have Insulation Class F or better

On 400/460 VAC models, the motor insulation system must be deemed suitable by the motor manufacturer for use on PWM (Pulse Width Modulated) IGBT (Insulated Gate Bipolar Transistor) variable frequency drives. These are also referred to as inverter-rated motors.

The VFD66 controls are suitable for use with thermally protected motors or motors intended by their manufacturer for fan speed modulating applications.

Multiple Motors

A VFD66 control can control multiple motors; however, the sum of the Full Load Amperes (FLA) ratings for the motors must not exceed the maximum output amperage rating of the VFD66 control, including any de-rating due to altitude and/or temperature.

Ordering Information

To select the proper model of the VFD66 control for a specific application:

1. Locate the nameplate (dataplate) on the motors intended for use with the VFD66 control. 400/460 VAC motors for use with the VFD66 controls must be inverter-rated motors. See *Selecting a Motor* for further information.
2. Identify the FLA ratings of each motor to be controlled by the VFD66 control. If more than one motor will be controlled, add the ratings of all the motors to determine the total FLA.
3. Adjust the VFD66 control's current rating for temperature and altitude. See *De-Rating the VFD66 Control for High Temperatures and High Altitudes*.
4. Compare the sum of the amperage draw of the motors to the adjusted current rating of the VFD66 control. If the current required is between two VFD66 control models, select the model with the higher amperage rating.
5. Configure the product number of the desired VFD66 control by adding the appropriate 3-letter suffix to VFD66. (See Table 15 for product number configuration. See Table 16 and Table 17 for standard models. See Table 2 for accessories.)

For example, a **VFD66BAA** would be a **VFD66** control rated at 1.8 amperes, 460 VAC at 60 Hz (**B**), NEMA 1 enclosure (**A**), Dual analog input signal (**A**).

Contact Johnson Controls/PENN application engineering at 1-800-275-5676 for more information.

Table 15: Ordering Information (Not all combinations are possible.)

VFD66 Series	Condenser Fan Speed Controls	
A	208/230 VAC, 60 Hz (230 VAC, 50 Hz), 4.0 amperes*	
B	460 VAC, 60 Hz (400 VAC, 50 Hz), 1.8 amperes*	
C	208/230 VAC, 60 Hz (230 VAC, 50 Hz), 7.5 amperes*	
D	460 VAC, 60 Hz (400 VAC, 50 Hz), 3.6 amperes*	
E	208/230 VAC, 60 Hz (230 VAC, 50 Hz), 10.6 amperes*	
F	460 VAC, 60 Hz (400 VAC, 50 Hz), 5.5 amperes*	
A	NEMA 1 Enclosure	
B	NEMA 1 Enclosure with Fan	
E	NEMA 4 Enclosure	
A	0-5 VDC or 0-10 VDC Dual Analog Input Signal	
E	0-5 VDC or 0-10 VDC Dual Analog Input Signal with Alarm Output	

* Maximum output ampere ratings. See *De-Rating the VFD66 Control for High Temperatures and High Altitudes* for temperature and altitude effects.

Table 16: Ordering Table for NEMA 1 Enclosure Models

Voltage Rating	Ampere Rating ¹	Product Code Numbers		
		Control Only	Control with One P35 Transducer	Control Only, Alarm Output
208/230 VAC, 60 Hz (230 VAC, 50 Hz)	4.0	VFD66AAA-1C	VFD66AAA-100C	VFD66AAE-1C
	7.5	VFD66CAA-1C	VFD66CAA-100C	VFD66CAE-1C
	10.6	VFD66EBA-1C ²	VFD66EBA-100C ²	VFD66EBE-1C ²
460 VAC, 60 Hz (400 VAC, 50 Hz)	1.8	VFD66BAA-1C	VFD66BAA-100C	VFD66BAE-1C
	3.6	VFD66DAA-1C	VFD66DAA-100C	VFD66DAE-1C
	5.5	VFD66FBA-1C ²	VFD66FBA-100C ²	VFD66FBE-1C ²

1. Maximum output ampere rating shown. See *De-Rating the VFD66 Control for High Temperatures and High Altitudes* for temperature and altitude effects on rating.
2. NEMA 1 Enclosure with Fan

Table 17: Ordering Table for NEMA 4 Enclosure Models with Alarm Output

Voltage Rating	Ampere Rating*	Product Code Numbers
208/230 VAC, 60 Hz (230 VAC, 50 Hz)	4.0	VFD66AEE-1C
	7.5	VFD66CEE-1C
460 VAC, 60 Hz (400 VAC, 50 Hz)	1.8	VFD66BEE-1C
	3.6	VFD66DEE-1C

* Maximum output ampere rating shown. See *De-Rating the VFD66 Control for High Temperatures and High Altitudes* for temperature and altitude effects on rating.

Repairs and Replacement

Field repairs of the VFD66 control should not be made. For a replacement VFD66 control or input devices, contact your local Johnson Controls/PENN distributor.

Technical Specifications

Product	VFD66 Series Condenser Fan Speed Controls
Input Power	208/230 VAC or 460 VAC @ 60 Hz (230 VAC or 400 VAC @ 50 Hz)
Output Voltage/Frequency	208/230 VAC or 460 VAC @ 60 Hz (230 VAC or 400 VAC @ 50 Hz)
Pulse Width Modulation Carrier Frequency	2.3 kHz
Duty	Continuous
Overload Capacity	110% of ampere rating for 1 minute
Maximum Output Ampere Limit	110% of ampere rating, non-adjustable
Acceleration/Deceleration	Selectable - 5 seconds or 30 seconds
Start/Stop	Line start with single auto-restart 30 seconds after fault
Lead Length	Maximum lead length between motor and VFD66 control is 50 ft (15 m).
Ambient Temperature	Storage: -40 to 158°F (-40 to 70°C) Operating: -40 to 140°F (-40 to 60°C) – See <i>De-Rating</i> .
Altitude	3300 ft (1000 m) maximum without de-rating maximum output amperes – See <i>De-Rating</i> .
Relative Humidity	0 to 95% noncondensing (storage and operating)
Available Enclosures	NEMA 1, UL Type 1 convection cooled (Some are fan cooled.) NEMA 4 convection and internal fan cooled Enclosures have three 1/2-in. trade size conduit openings.
Agency Listings	UL Listed, File E184521, Guides NMMS (UL 508C) and NMMS7 (CSA C22.2 No. 14).
Emissions Compliance	FCC (US), DOC (Canada), based on EU testing with items installed, shown in Figure 10 NEMA 1 Models - EU Directive Compliance (CE mark); 72/23/EEC (Low Voltage Directive) and 89/336/EEC (EMC Directive) compliance with items installed.
Input Devices	Johnson Controls/PENN (A350P, P35, P352P, P399, Performer Rack Controllers) Johnson Controls/Metasys® system (AHU, DME, DX9100, UNT, VAV) Also works with rack controllers, electronic pressure transducers, and other 0-5 VDC or 0-10 VDC input signal devices made by various manufacturers.
Dimensions (H x W x D)	See Figure 2, Figure 3, and Figure 4.
Shipping Weight	NEMA 1 Enclosure models – 5.6 lb (2.5 kg) NEMA 4 Enclosure (small enclosure) models – 5.6 lb (2.5 kg) NEMA 4 Enclosure (large enclosure) models – 7.2 lb (3.3 kg)

The performance specifications are nominal and conform to acceptable industry standards. For application at conditions beyond these specifications, consult Johnson Controls/PENN Refrigeration Application Engineering at 1-800-275-5676. Johnson Controls, Inc. shall not be liable for damages resulting from misapplication or misuse of its products.



Controls Group
507 E. Michigan Street
P.O. Box 423
Milwaukee, WI 53201

Published in U.S.A.
www.johnsoncontrols.com