



TECHNICAL GUIDE

MILLENNIUM®

SINGLE PACKAGE ROOFTOP UNITS

25, 30, & 40 TON

25 TON (10 EER)
30 & 40 TON (9.5 EER)

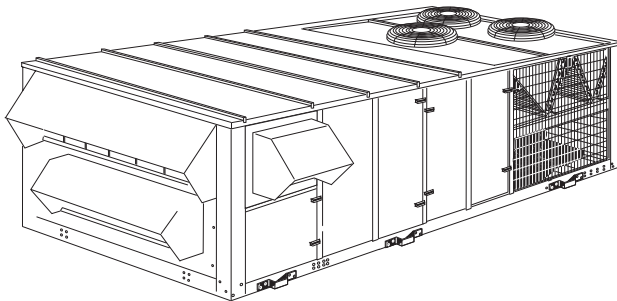

30 TON UNIT SHOWN



TOMORROW'S UNIT TODAY

GENERAL

Introducing the YORK Millennium 25, 30, & 40 ton rooftop line - units designed to provide peak performance and value both today and for years to come. Millennium units are manufactured at an ISO 9001 registered facility, and each rooftop is completely computer-run tested prior to shipment.

The Millennium is designed to be flexible enough to meet your needs today and in the future. The true value of YORK's Millennium is that it can be designed to fit any need, from cooling only, constant volume applications to variable air volume systems with variable frequency drive.

FEATURING:

- Cooling Only Units
- Cooling/Gas Heating Units (Natural Gas or Propane)
- Cooling/Electric Heating Units
- Cooling/Hot Water Heating Units
- Cooling/Steam Heating Units
- Industry Leading Efficiency
- Double Wall Construction
- Stainless Steel Drain Pan
- Multiple Scroll Compressors
- Multiple Refrigeration Circuits
- Upgradable Motor Efficiency
- Enhanced Filtration
- Vibration Isolated Supply Fan/Motor
- Technicoated Condenser Coils
- High Capacity Evaporator Coils
- Single Power Point Connection
- Easy Access Hinged Doors
- Variable Air Volume
- Constant Air Volume
- Factory Installed Economizers/Disconnect/Convenience Outlet/Control Options
- Low Profile

MILLENNIUM SIMPLICITY® ELITE™ FEATURES:

- Single Button Programming and LED Display
- Designed to operate on both constant and variable air volume units
- 365-Day real time clock with automatic Daylight Savings time adjustment
- Occupancy Schedule allowing two schedules per day
- 20 Holiday schedules with programmable schedules that can start at any time, day or night
- Patented Comfort Ventilation operation for economical and comfortable economizer operation
- Demand Ventilation option to assure proper IAQ conditions based on available space or return air CO₂ levels
- Temperature/Humidity programming algorithm allows programmable limits to help control humidity in the space
- Smoke Purge automatically ventilates the space when smoke is detected
- Monitors dirty filters and proves airflow before starting heating or cooling
- Intelligent recovery to bring the space temperature up to occupied setting quicker and more economically

TABLE OF CONTENTS

GENERAL	AIR FILTERING SYSTEM
FEATURING	OPTIONAL
MILLENNIUM SIMPLICITY FEATURES	AIR INLET SYSTEM
OVERVIEW	GENERAL
FEATURES AND BENEFITS	ECONOMIZER (OPTIONAL)
INSTALLATION FEATURES	RELIEF SYSTEM (OPTIONAL)
CONSTRUCTION FEATURES	BAROMETRIC RELIEF (OPTIONAL)
LIST OF FEATURES AND BENEFITS	EXHAUST AIR FANS (OPTIONAL)
STANDARD FEATURES	HEATING SYSTEM
FACTORY INSTALLED OPTIONS	GAS-FIRED HEATING SECTION (OPTIONAL)
ACCESSORIES	ELECTRIC HEATING SECTION
NOMENCLATURE	HOT WATER HEATING COIL
SELECTION PROCEDURE	STEAM HEATING COIL
SELECT UNIT:	REFRIGERATION SYSTEM
SELECT FAN SPEED AND HORSEPOWER	EVAPORATOR COILS
REQUIREMENTS OF SUPPLY AIR FAN	COMPRESSORS
SIZE OVERCURRENT PROTECTION DEVICE AND	CONDENSER COILS
DETERMINE CIRCUIT AMPACITY	CONDENSER FANS AND MOTORS
HOT WATER HEATING	REFRIGERANT PIPING
PHYSICAL DATA HOT WATER COIL - 1 ROW	HOT GAS BYPASS (OPTIONAL ON CV; STANDARD
PIPING CONNECTIONS	ON VAV)
PHYSICAL DATA HOT WATER COIL - 2 ROW	CONTROLS
STEAM HEATING	GENERAL DESCRIPTION
PHYSICAL DATA STEAM COIL - 1 ROW	COMPRESSOR CONTROL
PIPING CONNECTIONS	FAN CONTROL
SUPPLY AIR DRIVE ADJUSTMENT	EQUIPMENT CONTROL FEATURES
CFM, STATIC PRESSURE, AND POWER-ALTITUDE	COMFORT CONTROL FEATURES
AND TEMPERATURE CORRECTIONS	AVAILABLE ACCESSORIES
GUIDE SPECIFICATIONS - YORK	FULL PERIMETER AND PARTIAL PERIMETER ROOF
MILLENNIUM 25, 30, & 40 TON UNITS	CURBS
GENERAL	BURGLAR BARS
DESCRIPTION	FIELD INSTALLED BAROMETRIC RELIEF
CONSTRUCTION	PROGRAMMABLE THERMOSTAT, WITH OR WITHOUT
BASE	REMOTE SENSOR (REQUIRED FOR CONSTANT
CASING	VOLUME UNITS)
SUPPLY AIR SYSTEM	REMOTE WALL MOUNTED TEMPERATUR
SUPPLY AIR FAN	SENSORS
OPTIONAL	DIRTY FILTER SWITCH
BEARINGS AND DRIVES	NATURAL GAS AND PROPANE CONVERSION
	KITS
	HIGH ALTITUDE CONVERSION KITS

LIST OF FIGURES

<u>Fig.#</u>		<u>Pg.#</u>	<u>Fig.#</u>		<u>Pg.#</u>
1	HOT WATER PIPING CROSS-SECTION	13	19	STEAM COIL - 25 & 30 TON, 1 ROW	24
2	HOT WATER COIL - 25 & 30 TON, 1 ROW, AT 10 GPM	14	20	STEAM COIL - 40 TON, 1 ROW	24
3	HOT WATER COIL - 25 & 30 TON, 1 ROW, AT 20 GPM	14	21	ALTITUDE/TEMPERATURE CONVERSION FACTOR	49
4	HOT WATER COIL - 25 & 30 TON, 1 ROW, AT 30 GPM	15	22	FAN PERFORMANCE - 25 TON	51
5	HOT WATER COIL - 25 & 30 TON, 1 ROW, AT 40 GPM	15	23	FAN PERFORMANCE - 30 TON	53
6	HOT WATER COIL - 40 TON, 1 ROW, AT 10 GPM..	16	24	FAN PERFORMANCE - 40 TON	55
7	HOT WATER COIL - 40 TON, 1 ROW, AT 20 GPM..	16	25	POWER EXHAUST - ONE FORWARD CURVE FAN - 25 TONS	58
8	HOT WATER COIL - 40 TON, 1 ROW, AT 30 GPM..	17	26	POWER EXHAUST - TWO FORWARD CURVED FANS - 30 & 40 TONS	60
9	HOT WATER COIL - 40 TON, 1 ROW, AT 40 GPM..	17	27	CENTER OF GRAVITY	77
10	HOT WATER COIL - 25 & 30 TON, 2 ROW, AT 20 GPM	19	28	COMPONENT LOCATION	79
11	HOT WATER COIL - 25 & 30 TON, 2 ROW, AT 40 GPM	19	29	END RETURN, BOTTOM SUPPLY	80
12	HOT WATER COIL - 25 & 30 TON, 2 ROW, AT 60 GPM	20	30	BOTTOM SUPPLY AND RETURN	81
13	HOT WATER COIL - 25 & 30 TON, 2 ROW, AT 80 GPM	20	31	BOTTOM RETURN, FRONT & REAR SUPPLY	82
14	HOT WATER COIL - 40 TON, 2 ROW, AT 20 GPM..	21	32	END RETURN, FRONT & REAR SUPPLY	83
15	HOT WATER COIL - 40 TON, 2 ROW, AT 40 GPM..	21	33	MILLENNIUM OVERHEAD VIEW	84
16	HOT WATER COIL - 40 TON, 2 ROW, AT 60 GPM..	22	34	MILLENNIUM MAJOR COMPONENT LAYOUT	84
17	HOT WATER COIL - 40 TON, 2 ROW, AT 80 GPM..	22	35	CLEARANCES - HOOD/ECONOMIZER & MOTOR DRIVE - SIDE	84
18	STEAM PIPING CROSS SECTION	23	36	CLEARANCES - HOOD/ECONOMIZER & MOTOR DRIVE - FRONT & END	84
			37	PARTIAL ROOF CURB MODEL 1RC0455P	85
			38	FULL ROOF CURB MODEL 1RC0455F	86

LIST OF TABLES

<u>Tbl.#</u>	<u>Pg.#</u>	<u>Tbl.#</u>	<u>Pg.#</u>
1	10	30	40
2	11	31	44
3	12	32	48
4	12	33	50
5	13	34	52
6	13	35	54
7	13	36	56
8	13	37	57
9	13	38	59
10	18	39	61
11	18	40	61
12	18	41	61
13	18	42	62
14	18	43	63
15	18	44	64
16	23	45	65
17	23	46	66
18	23	47	67
19	23	48	68
20	25	49	71
21	25	50	74
22	27	51	77
23	27	52	77
24	27	53	78
25	28	54	78
26	28	55	78
27	29	56	79
28	32		
29	36		

YORK Millennium®

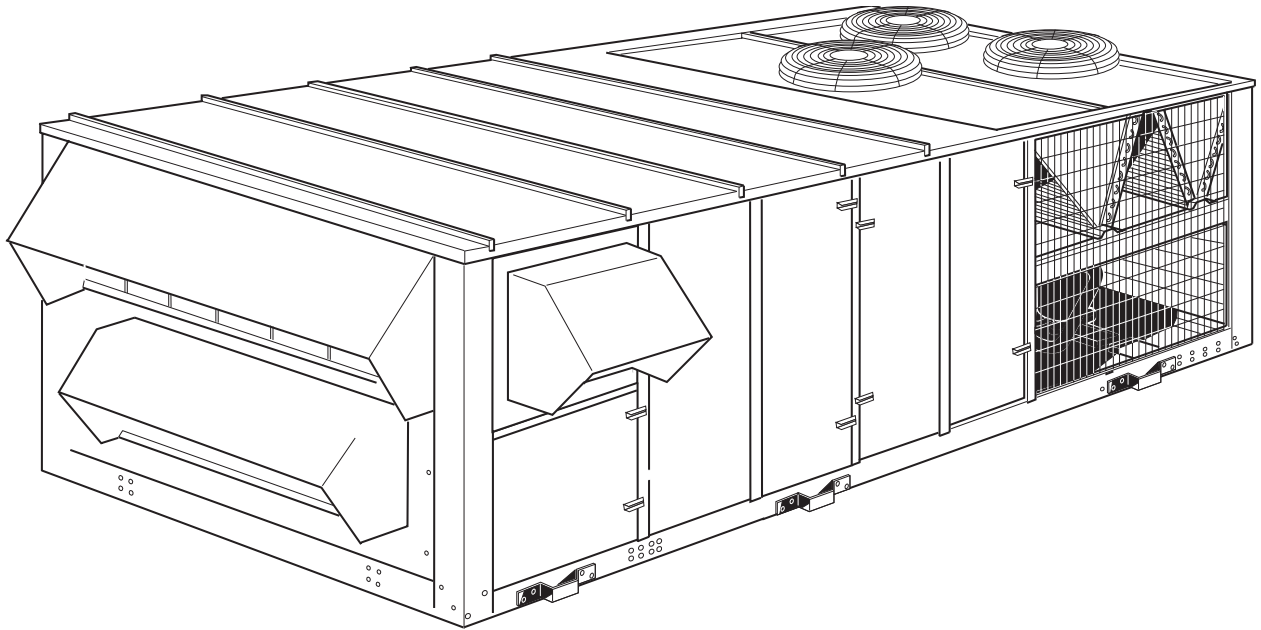

OVERVIEW

Introducing the YORK Millennium 25, 30, & 40 ton rooftop line - units designed to provide peak performance and value both today and for years to come. When we asked our customers what they wanted in a new rooftop line, we were careful to listen to both the needs of today and tomorrow. So, you'll find that Millennium units not only help you solve today's problems, but can handle tomorrow's difficulties as well:

Industry Leading Efficiency - The Millennium's 9.5 EER (10 EER 25 ton) rating makes it the most frugal energy consumer in its class. When it comes to lower operating costs, Millennium simply outperforms the competition.

Double Wall Construction - Millennium units come double walled as standard. The galvanized sheet metal liner provides the best protection against microbial growth, helping both the unit and the indoor air stay fresh and clean. And, the rigid sheet metal inner liner keeps the insulation completely out of the air stream, eliminating concerns about fiberglass particles.

Drain Pan Whisks Away Condensate - Condensate is frequently the source of microbial contamination. Competitive drain pans often are insufficiently sloped to properly drain all of the condensate, causing drain pan corrosion and bacterial growth to begin almost immediately. The YORK design is stainless steel, for long life. And, it is sloped at the 1/4" per foot recommended by the new ASHRAE ventilation draft standard, with an extra large drain connection capable of removing up to three gallons of condensate per minute. Best of all, the drain pan is easily removed from the unit so that it can be cleaned at regular intervals.

Efficient, Durable Scroll Compressors - The Millennium design uses industrial grade hermetic scroll compressors for peak efficiency and low noise operation. The compressor design is so durable that it can actually hold more liquid charge without slugging than is present in each refrigerant circuit at shipment, dramatically reducing the chances of ever slugging a compressor with liquid charge.

Multiple Refrigeration Circuits for Greater Turndown - The YORK Millennium unit has intertwined 10 ton circuits (12.5 ton circuits on the 25 ton) - giving the best unloading capability in the industry. With more and more designs requiring higher outside air quantities, the lower capacity capability is an outstanding way to neutralize outside air without over-conditioning the space on off-peak days. And, Millennium's high quality balance-port thermal expansion valves are more effective at metering refrigerant flow in part-load conditions, making Millennium a peak-performer across a wide capacity range.

FEATURES AND BENEFITS

When it comes to flexibility, Millennium really shines. Our customers were clear about one thing - not all installations are the same. Some have very simple needs, others are more involved. The YORK Millennium serves both markets - and all of those in between - extremely well. YORK engineers crafted a design which is both uniquely flexible and competitive, giving you the best of both worlds. In addition to a competitive base product, Millennium offers unparalleled flexibility. Optional features include:

Variable Air Volume - YORK gives you the ability to vary air volume by inlet guide vanes or variable frequency drive - the choice is yours. All Millennium VAV units come standard with hot gas bypass to give extended operation range.

Optional Head Pressure Control - For those applications where mechanical cooling is required below 40°F, optional low ambient operation allows compressor operation down to 0°F.

Easily Upgrade Motor Efficiency to Meet Tighter Codes - Optional high efficiency motors help you make simple upgrades to meet more demanding building and energy codes.

Enhanced Filtration Options - Millennium gives designers the flexibility to meet various IAQ requirements with a full range of rigid and throwaway filters at different efficiency levels.

Vibration Isolation - The Millennium's 1" isolator springs are typically sufficient for most applications, but when sound and vibration transmission are a major concern, YORK offers 2" isolation springs for even greater protection from supply air fan noise and vibration.

Optional TechniCoated Coated Condenser Coils - Many industrial and seacoast applications require enhanced protection from corrosive environments. The special dipped phenolic coating process provides a high level of protection for the exposed condenser coil.

High Capacity Evaporator Coils - For those applications which require slightly more capacity than offered by the standard Millennium product, YORK offers the option of higher capacity evaporator coils, boosting cooling output without increasing unit size.

Variety of Exhaust Air Options - YORK Millennium offers a wide variety of exhaust air options, including barometric relief, non-modulating power exhaust, and modulating power exhaust. And, because Millennium units use forward-curved blowers for power exhaust fans, they can exhaust up to 100% of the nominal supply air at much greater static pressure loads than competitive units. **Not available on end return.**

Optional Factory Installed Economizers - Millennium units offer an optional factory installed economizer with low leak dampers. Comparative enthalpy, single enthalpy and dry bulb control are available.

Optional Factory Installed Disconnect - A conveniently located actuator handle in the front of the unit can disconnect line power to the entire unit, eliminating the need for a field provided disconnect. The handle may also be locked in either position through the use of a standard padlock. Millennium's single point power connection makes this option particularly appealing. If desired, the disconnect may be ordered with a 115 volt, GFCI protected convenience outlet, including a factory wired transformer to power the outlet from the single point power connection; the convenience outlet remains operational when the disconnect is open.

Heating Done Your Way - Millennium offers the choice of natural gas or propane, electric resistance heat, hot water heat, steam, or no heat at all. Very simply, the choice is yours.

INSTALLATION FEATURES

With YORK Millennium, high performance doesn't mean high complexity. YORK listened carefully to make sure that Millennium was as simple as possible, and service convenience comes standard with each unit. From a single curb size to the easy service access, you'll find that Millennium was designed to be easy from start to finish.

Full Range of Air Flows and Static Pressures - The Millennium design gives a complete offering of supply air flows and static pressure combinations to meet most every application requirement.

Single Power Point Connection - Millennium units have a single gas and electric connection, minimizing time at the job site. For further installation flexibility, power and gas connections may be brought up from the curb or through the side of the unit.

Simple Controls - Millennium's controls system is easy to understand and apply, and it doesn't lock you into proprietary devices. A choice for YORK Millennium today does not limit your choices tomorrow.

Rain Hoods Rotate Into Place - No bulky, field-installed rain hoods here. Millennium rain hoods ship rotated inside the unit. Once on the job, installer merely rotates the hood upward and puts in a few screws - an easy one-person job.

Excellent Access for Service - Service access on Millennium is a snap. Hinged and latched doors give access on both sides of the unit to all major components. All doors have positive action slide latches for even greater ease of access. All service fittings are conveniently located to minimize time and effort.

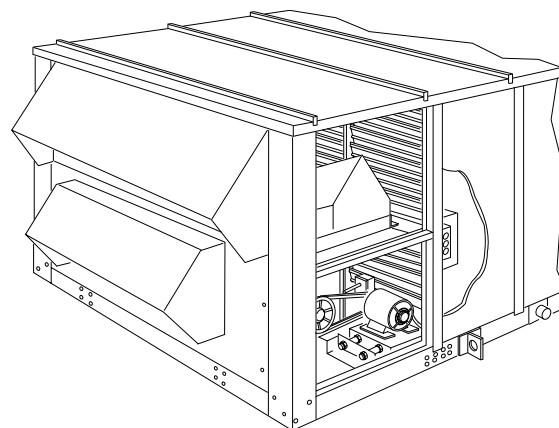

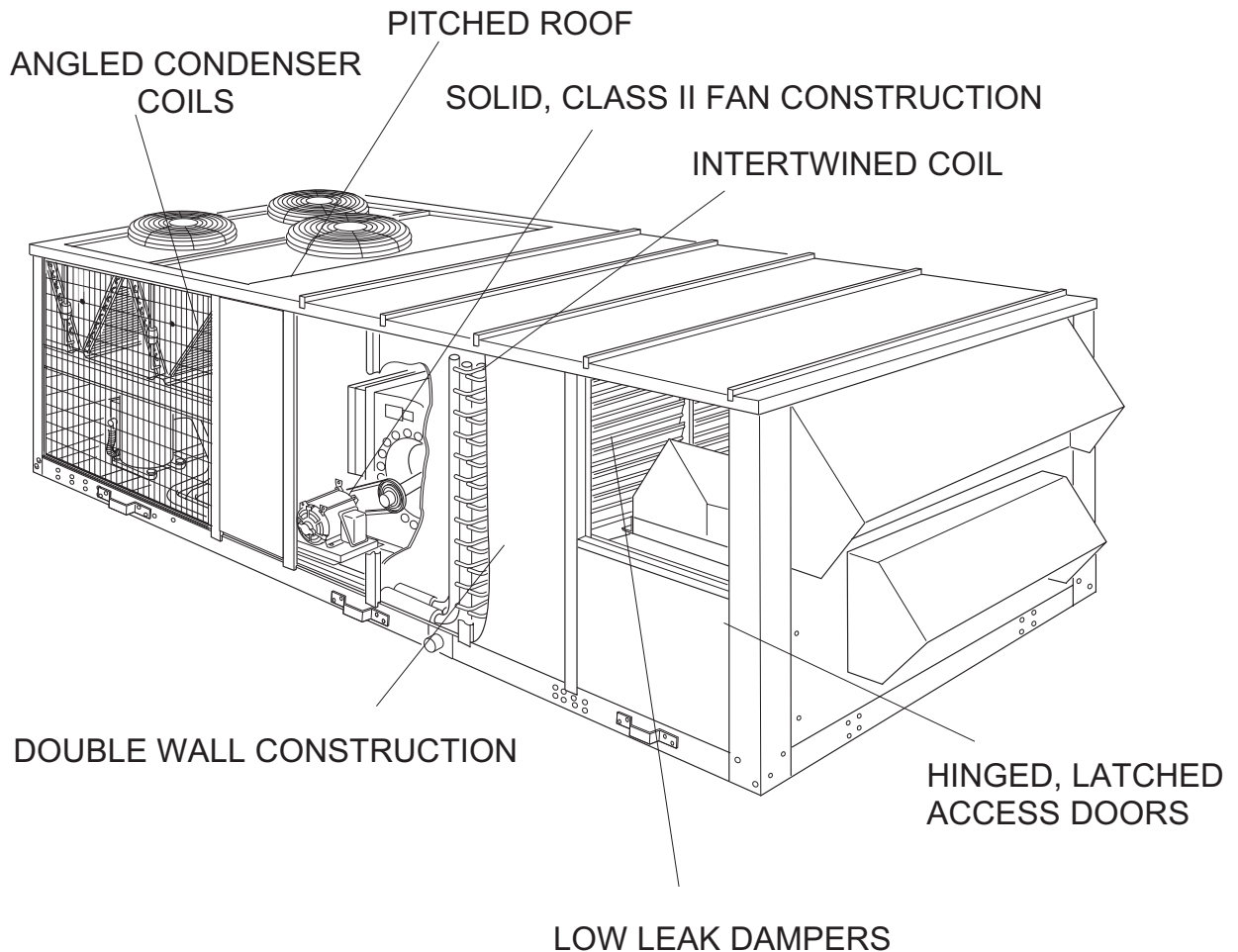

CONSTRUCTION FEATURES

YORK's Millennium rooftop line is built for the long haul, with high end features and construction offered at a competitive price. Millennium units are manufactured at an ISO 9001 registered facility, and each rooftop is completely computer-run tested prior to shipment. Some of the valuable construction features of the Millennium which are not found on competitive units include:

Double Wall Construction - Each unit has both an exterior and an interior wall, which make for a more rigid design with panels and doors that are solid, not flimsy. The unit features a fully framed construction for even greater stability.

Powder Paint - Industry leading 1000 salt spray hour paint keeps the unit in great condition for years to come.

Low Profile - Millennium units stand only 64" above their curb, minimizing potential aesthetic conflicts.

Extended flue connection - Each gas unit ships with a field mounted external flue. The flue lifts all products of furnace combustion far above the unit - eliminating the possibility of corrosion in the furnace heat exchanger from recirculating flue gases.

Protective Covering - Special polyurethane sleeves which cover the distributor tubing keep distributor tubes from contacting each other and wearing out.

Built-in Hail Guard - Condenser coils angled at 30 degrees from the vertical are inherently protected from damage due to shipment, hail, etc.

Induced Draft Furnace - This design provides a positive exhaust of all combustion products.

LIST OF FEATURES AND BENEFITS

Standard Features

- 9.5 EER (10 EER on 25 ton)
- Double wall construction
- Hinged and latched access doors
- Industrial duty scroll compressors
- Sturdy framed construction
- Sloped stainless steel drain pan
- Separate 10 ton circuits (30 and 40 ton units) or 12.5 ton (25 ton unit)
- Intertwined evaporator coil
- Angled condenser coils for superior protection
- Single power point connection
- Through-the-curb or through-the-base utility connections
- Retractable outside air hoods
- Powder paint tested to 750 salt spray hours
- Mechanical cooling from 40° F to 120° F
- 1-1/2" insulation
- Sloped unit roof with drip lip
- High and low refrigerant pressure protection
- Polyurethane sleeves to protect small diameter tubing
- Steel framing around blowers with 1" deflection springs for low vibration
- Fully factory packaged and run-tested
- 10 year gas heat exchanger warranty
- One year compressor warranty
- One year warranty on all parts

Accessories

- Programmable thermostat - with or without remote sensor
- Remote space sensor
- Night setback thermostat for VAV
- Supply air setpoint reset by outside air or space air temperature
- Remote supply air setpoint adjustment
- Seven day time clock
- Ventilation override
- Remote economizer minimum position adjustment
- Full perimeter and partial perimeter roof curbs
- Burglar Bars that match the supply and return openings of either the full or partial perimeter curbs.
- Duct mounted barometric relief assembly (for use with end return applications)
- Natural gas and propane conversion kits
- High altitude conversion kits

Factory Installed Options

- Economizer with low leak dampers
- Natural gas heat with reliable induced draft design
- Electric heat in three sizes
- Variable air volume with either inlet guide vanes wired for VFD variable frequency drive, or factory installed VFD.
- 2" blower isolator springs
- A variety of blower horsepower offerings
- High efficiency motors
- High efficiency filtration
- Barometric relief
- Power exhaust of 100% of nominal air flow
- Technicoat corrosive resistant coating on condenser coils
- 0°F low ambient operation of mechanical cooling
- Hot gas bypass (standard on all VAV units)
- High capacity evaporator coils
- Single unit disconnect
- Convenience outlet and transformer factory wired
- Hot water heating coil with one or two rows
- One row steam heating coil
- Simplicity[®] Elite[™] controls

NOMENCLATURE

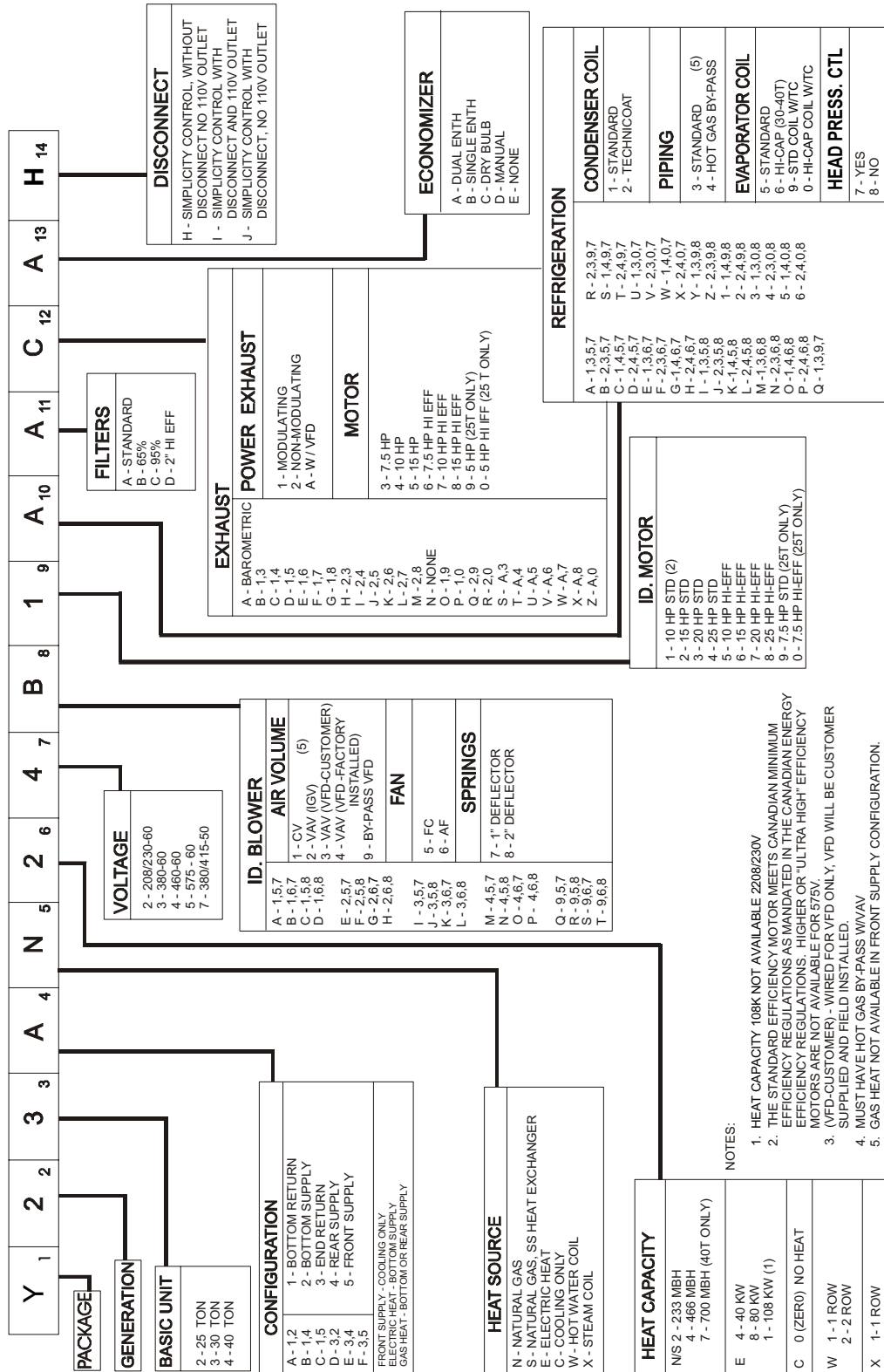

TABLE 1: GENERAL PHYSICAL DATA

UNIT SIZE	25 TON	30 TON	40 TON
UNIT EER / IPLV (STANDARD CAPACITY EVAPORATOR)	10.0 / 10.92	9.5 / 10.97	9.5 / 9.73
COMPRESSOR DATA			
NUMBER/SIZE	2 x 13 Ton	3 x 10 Ton	4 x 10 Ton
TYPE	Scroll	Scroll	Scroll
UNIT CAPACITY STEPS	50%, 100%	33%, 67%, 100%	25%, 50%, 75%, 100%
INDOOR FAN AND DRIVE			
NUMBER / TYPE	1 / FC	1 / FC	1 / FC
DIAMETER X WIDTH (INCHES)	22 x 20	22 x 20	25 x 22
HP RANGE	7.5 - 20	10 - 25	10 - 25
CFM RANGE (FULL LOAD)	6,000 - 12,500	6,000 - 15,000	8,000 - 18,000
ESP RANGE	0.2" - 4.0"	0.2" - 4.0"	0.2" - 4.0"
EXHAUST FAN			
NUMBER/SIZE/TYPE	1/FC	2/FC	2/FC
HP RANGE (SINGLE MOTOR)	5 - 10	7.5 - 15	7.5 - 15
CFM	3,000 - 9,000	4,000 - 18,000	4,000 - 18,000
STANDARD EVAPORATOR COIL			
SIZE (SQ. FT.)	26.0	26.0	30.4
ROWS/FPI	3 / 13	3 / 16	4 / 13
HIGH CAPACITY EVAPORATOR COIL			
SIZE (SQ. FT.)	26.0	26.0	30.4
ROWS/FPI	2/16	4 / 16	4 / 16
CONDENSER COIL			
SIZE (SQ. FT.)	52.0	48.8	65.0
ROWS/FPI	2/16	2 / 16	2 / 16
CONDENSER FANS			
QUANTITY / DIAMETER (INCHES)	4 / 24	3 / 24	4 / 24
NOMINAL CFM	4,600	6,800	6,800
MOTOR HP	3 / 4	1.0	1.0
ELECTRIC HEAT			
KW RANGE	40 - 108	40 - 108	40 - 108
40 kW CAPACITY STEPS	1	1	1
80 AND 108 kW CAPACITY STEPS (CV/VAV)	2 / 1	2 / 1	2 / 1
NATURAL GAS HEAT			
UNIT SIZE	25 TON	30 TON	40 TON
233 MBH CAPACITY STEPS (CV/VAV)	1 / 1	1 / 1	1 / 1
466 MBH CAPACITY STEPS (CV/VAV)	2 / 1	2 / 1	2 / 1
699 MBH CAPACITY STEPS (CV/VAV)	-	-	3 / 1
HOT WATER COIL			
SIZE (INCHES)	22.5" x 65"	22.5" X 65"	22.5" X 65"
CAPACITY	25 Ton	30 Ton	40 Ton
STEAM COIL			
SIZE (INCHES)		21" X 65"	
TYPE		Steam Coil	
FILTERS 2" HI. EFF. TA			
NUMBER / SIZE	4 / 16 x 25 & 6 / 20 x 25	4 / 16 x 25 & 6 / 20 x 25	4 / 16 x 25 & 6 / 20 x 25
FACE AREA (SQ. FT.)	30.4	30.4	30.4
FILTERS 2" PLEATED, 65%			
NUMBER / SIZE	4 / 16 x 25 & 6 / 20 x 25	4 / 16 x 25 & 6 / 20 x 25	4 / 16 x 25 & 6 / 20 x 25
FACE AREA (SQ. FT.)	30.4	30.4	30.4
FILTERS 65% RIGID W/ 2" TA PREFILTERS			
NUMBER / SIZE	4 / 16 x 25 & 6 / 20 x 25	4 / 16 x 25 & 6 / 20 x 25	4 / 16 x 25 & 6 / 20 x 25
FACE AREA (SQ. FT.)	30.4	30.4	30.4
FILTERS 95% RIGID W/ 2" TA PREFILTERS			
NUMBER / SIZE	4 ea. 16 x 25 / 6 ea. 20 x 25	4 ea. 16 x 25 / 6 ea. 20 x 25	4 ea. 16 x 25 / 6 ea. 20 x 25
FACE AREA (SQ. FT.)	30.4	30.4	30.4

TABLE 2: REFRIGERANT CHARGE

UNIT (Tons)	MODEL	TYPE	FACTORY/ FIELD CHARGED	CHARGE			
				SYS #1	SYS #2	SYS #3	SYS #4
25	wo/HGBP	R22	Factory	27 lb. / 0 oz.	26lb / 0oz	-	-
25	w/HGBP	R22	Factory	27 lb. / 8 oz.	26 lb. / 0oz	-	-
30	wo/HGBP	R22	Factory	13 lb. / 4 oz.	13 lb. / 8 oz.	13 lb. / 8 oz.	-
30	wo/HGBP ¹	R22	Factory	14 lb. / 6 oz.	14 lb. / 10 oz.	14 lb. / 10 oz.	-
30	w/HGBP ¹	R22	Factory	14 lb. / 0 oz.	13 lb. / 8 oz.	13 lb. / 8 oz.	-
30	w/HGBP	R22	Factory	15 lb. / 2 oz.	14 lb. / 10 oz.	14 lb. / 10 oz.	-
40	wo/HGBP	R22	Factory	15 lb. / 5 oz.	15 lb. / 4 oz.	15 lb. / 5 oz.	15 lb. / 15 oz.
40	w/HGBP	R22	Factory	15 lb. / 13 oz.	15 lb. / 4 oz.	15 lb. / 5 oz.	15 lb. / 15 oz.

¹: With high capacity evaporator coil.

SELECTION PROCEDURE

GIVEN:

Required Cooling Capacity	460,000 Btuh
Required Sensible Cooling	390,000 Btuh
Required Heating (Gas)	320,000 Btuh
Entering Air on Evaporator	83° F DB/ 67° F WB
Outside Design Temperature	95° F
Supply Fan CFM	13,000 CFM
External Static Pressure	1.25 IWG
Electrical Supply Voltage	460-3-60
Economizer Required	
2" Throw Away Filters	
Constant Volume	

SELECT UNIT:

- Determine nominal tons:
 $460,000 / 12,000 = 38.33$ Tons
 Thus, a nominal 40 ton unit is selected.
- Reference Cooling Capacity Table for a 40 ton unit with standard evaporator coil.
 - Locate the table for a standard evaporator coil with 95° F air on the condenser.
 - Enter table at 13,000 CFM and 67°F WB air on evaporator
 - Trace to 83° F Entering Dry Bulb column.
 - Read 493 MBH total capacity and 403 MBH sensible capacity.

The 40 ton unit will meet the cooling requirements. From the nomenclature, the unit will be a Y14. Choose the appropriate configuration for the next digit. Assuming bottom return and supply, the fourth digit would be an "A," making the model Y14A.

- Find Gas Heating Capacity Table.
 - Trace down Output column.
 - Find output which exceeds 320,000 Btuh requirement. The N4 option gives 373 MBH output.
 - Ensure that it is offered in the Y14 unit. Read option model as N4.

From the basic nomenclature, the model now becomes Y14AN4. Add voltage code of "4" for 460-3-60. Nomenclature becomes Y14AN44.

SELECT FAN SPEED AND HORSEPOWER REQUIREMENTS OF SUPPLY AIR FAN

- Find Supply Air Performance Tables for the 40 ton unit.
 - Check footnotes and make necessary additions or deductions to static resistance of ductwork:
 Ductwork static resistance 1.25 IWG
 Economizer static resistance addition (interpolate) = .25 IWG
 IWG + Gas Heat (High) = 0.5 IWG
 Total Static Resistance 2.0 IWG
 - Enter Fan Performance Table at 13,000 CFM and 2.0 IWG static pressure:
 RPM = 690
 BHP = 10.2
 - Correct BHP for drive losses (using 1.05 correction factor). $10.2 \text{ BHP} \times 1.05 = 10.7 \text{ BHP}$. Enter the Fan Motor Drive Tables. Selecting a 15 hp motor allows (service factor of 1.5) for a maximum operating BHP greater than the 10.7 BHP requirement.

SIZE OVERCURRENT PROTECTION DEVICE AND DETERMINE CIRCUIT AMPACITY

1. Find electrical tables for the basic 40 ton unit.
 - a. Enter table for 460-3-60 voltage.
 - b. Find 15 hp in the Supply Air Fan column.

- c. Trace to Minimum Circuit Ampacity column - read 109.
- d. Trace to M.O.P.D. column - read 125.
- e. Size wire and overprotection device accordingly.
- f. Check all footnotes.

TABLE 3: GAS HEATING CAPACITIES

GAS HEAT OPTION	AVAILABLE ON MODELS	INPUT CAPACITY (MBH) ¹		OUTPUT CAPACITY (MBH) ²	GAS RATE, CU. FT./HR. ³		TEMP. RISE °F AT FULL RATE
		1ST STAGE	TOTAL		1ST STAGE	TOTAL	
N2	Y22/Y23/Y24	233	233	186	217	217	5 - 35
N4	Y22/Y23/Y24	233	466	373	217	434	15 - 45
N7 ⁴	Y24 ONLY	466	699	560	434	650	20 - 50

1. Heating capacity is only staged on CV models. VAV models use only one stage at full capacity.
2. Blower motor heat not included.
3. based on a heat content of 1075 Btu/Ft.³

$$\text{GAS RATE} = \frac{\text{Input MBH}}{(1.075 \text{ MBH})/\text{Ft}^3}$$

4. Minimum heating CFM for N7 700 MBH heat is 11,700 CFM.

TABLE 4: ELECTRIC HEATING CAPACITIES

ELECTRIC HEAT OPTION	AVAILABLE ON MODELS	RATED VOLTAGE	NOMINAL KW	NOMINAL MBH ¹	MBH AND KW PER STAGE ²			
					STAGE 1		STAGE 2	
					KW	MBH	KW	MBH
E4	Y22, Y23, Y24	240 ³ /480 ⁴ / 575	40	137	40	137	0	0
E8	Y22, Y23, Y24	240 ² /480 ³ / 575	80	273	40	137	40	136
E1	Y22, Y23, Y24 (460 & 575 volt only)	480 ³ /575	108	369	72	246	36	123

1. Supply air fan motor heat not included.
2. Heating capacity is only staged on CV models. VAV models use only one stage at full capacity.
3. For 208 volts, multiply kW and MBH values by .751. For 203 volts, multiply kW and MBH values by .918
4. For 460 volts, multiply kW and MBH values by .918.

HOT WATER HEATING¹

The YORK Millennium Rooftop units (30 - 40 Ton sizes) can be furnished with a YORK hot water coil as the source of heat (Bottom Supply Only). A one or two row coil will be factory installed in the heating section downstream of the supply air fan and just above the supply air opening in the bottom of the unit.

The hot water control valve will not be provided. The installer will need to field supply a water valve. The installer must also connect the hot water piping, and valve wiring at the job site for the hot water heat section to be operational.

For all hot water coils the entering water temperature should not exceed 200°F.

PHYSICAL DATA HOT WATER COIL - 1 ROW

Coil Casing	Galvanized Steel
Coil Construction	Al Fin / Cu. Tube
Rows Deep	1
Fin Thickness006"
Tube Wall016"
Tubes / Circuit	2
Fins Per Inch8
Tubes High22.50"
Tube Length	65"
Face Area	10.16ft. ²
Weight	71lbs.
Operating Weight	83lbs.

1. Hot water, steam or electric heat is not available for front or rear supply.

TABLE 5: WATER PRESSURE DROP (1 ROW, 25 & 30 TON)

GPM	10	20	30	40
WATER PRESSURE DROP	0.9	3.0	6.0	10.0

TABLE 6: STATIC RESISTANCE HOT WATER COIL (25 & 30 TON)

CFM	6000	8000	10000	15000
AIR PRESSURE DROP 1 ROW	0.07	0.11	0.16	0.32
AIR PRESSURE DROP 2 ROW	0.14	0.23	0.33	0.65

NOTE: Water pressure drop numbers are based on 60°F entering air temperature, 2.00" maximum air pressure drop across the hot water coil(s). ARI certified ratings at covering other conditions are available upon request. Hot water coils are approved for use with glycol (rates available upon request).

⚠ WARNING

DO NOT use tin based solder. Brazing with tin based solder could cause equipment damage or possible injury to OCCUPANTS of the structure that is being conditioned.

TABLE 7: HOT WATER COIL (1 ROW, 25 & 30 TON)¹

GPM	CFM	CAPACITY (MBH) AT ENTERING WATER TEMPERATURE			
		140 °F	160 °F	180 °F	200 °F
10	6000	91.4	115.3	139.3	163.6
	8000	102	128.8	155.8	182.9
	10000	110.4	139.5	168.8	198.4
	12000	117.3	148.4	179.6	211.2
	15000	125.9	159.2	192.9	226.9
20	6000	103	129.4	156	182.7
	8000	116.8	147	177.2	207.7
	10000	128.2	161.3	194.7	228.2
	12000	137.8	173.6	209.5	245.6
	15000	150	189	228.2	267.8
30	6000	107.6	135	162.5	190.1
	8000	122.8	154.3	185.8	217.5
	10000	135.5	170.3	205.1	240.2
	12000	146.4	184	221.8	259.7
	15000	160.3	201.6	243	284.8
40	6000	110.1	138	166	194.1
	8000	126.1	158.2	190.5	222.8
	10000	139.6	175.2	210.9	246.8
	12000	151.2	189.8	228.5	267.5
	15000	166.1	208.6	251.3	294.1

¹. Based on 60°F entering air temperature, 2.00" maximum pressure drop across the hot water coil.

PIPING CONNECTIONS

The hot water piping must enter the unit through the floor of the heat section compartment. The access doors to the compartment are gasketed so the compartment can be sealed. However, as added protection for water leakage into the space, the piping access holes should be sealed with a heat resistant mastic (see the following illustration for approximate location of the compartment and piping connections).

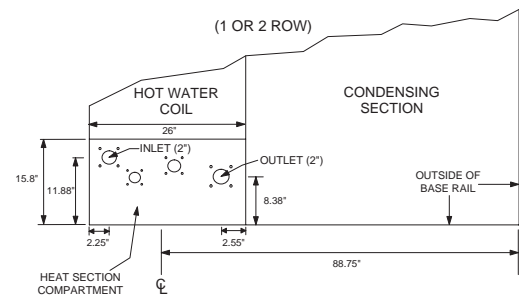

FIGURE 1 - HOT WATER PIPING CROSS-SECTION

TABLE 8: STATIC RESISTANCE HOT WATER COIL (1 ROW, 40 TON)

CFM	8000	11000	14000	20000
AIR PRESSURE DROP 1 ROW	0.11	0.19	0.29	0.52
AIR PRESSURE DROP 2 ROW	0.23	0.39	0.58	1.06

TABLE 9: HOT WATER COIL (1 ROW 40 TON)¹

GPM	CFM	CAPACITY (MBH) AT ENTERING WATER TEMPERATURE			
		140 °F	160 °F	180 °F	200 °F
10	8000	102	128.8	155.8	182.9
	11000	114	144.1	174.4	205.1
	14000	123.2	155.9	188.8	222.1
	17000	130.6	165.4	200.4	235.8
	20000	136.8	173.3	210.1	247.3
20	8000	116.8	147	177.2	207.7
	11000	133.2	167.7	202.3	237.2
	14000	146.2	184.2	222.4	260.8
	17000	157	197.9	239	280.5
	20000	166.2	209.6	253.2	297.3
30	8000	122.8	154.3	185.8	217.5
	11000	141.2	177.4	213.8	250.3
	14000	155.9	196.1	236.4	276.9
	17000	168.3	211.8	255.4	299.3
	20000	179.1	225.3	271.8	318.6
40	8000	126.1	158.2	190.5	222.8
	11000	145.6	182.7	220	257.5
	14000	161.4	202.6	244.1	285.8
	17000	174.7	219.5	264.5	309.7
	20000	186.3	234.2	282.3	330.6

¹. Based on 60°F entering air temperature, 2.00" maximum pressure drop across the hot water coil.

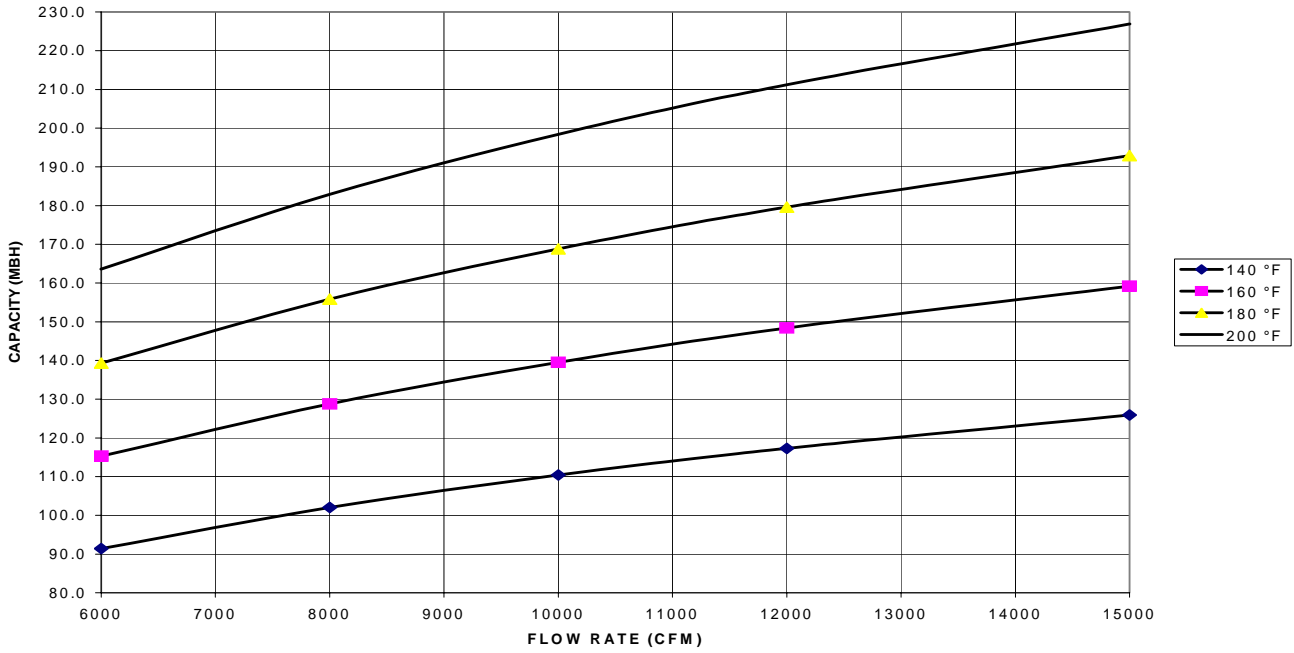

FIGURE 2 - HOT WATER COIL - 25 & 30 TON, 1 ROW, AT 10 GPM

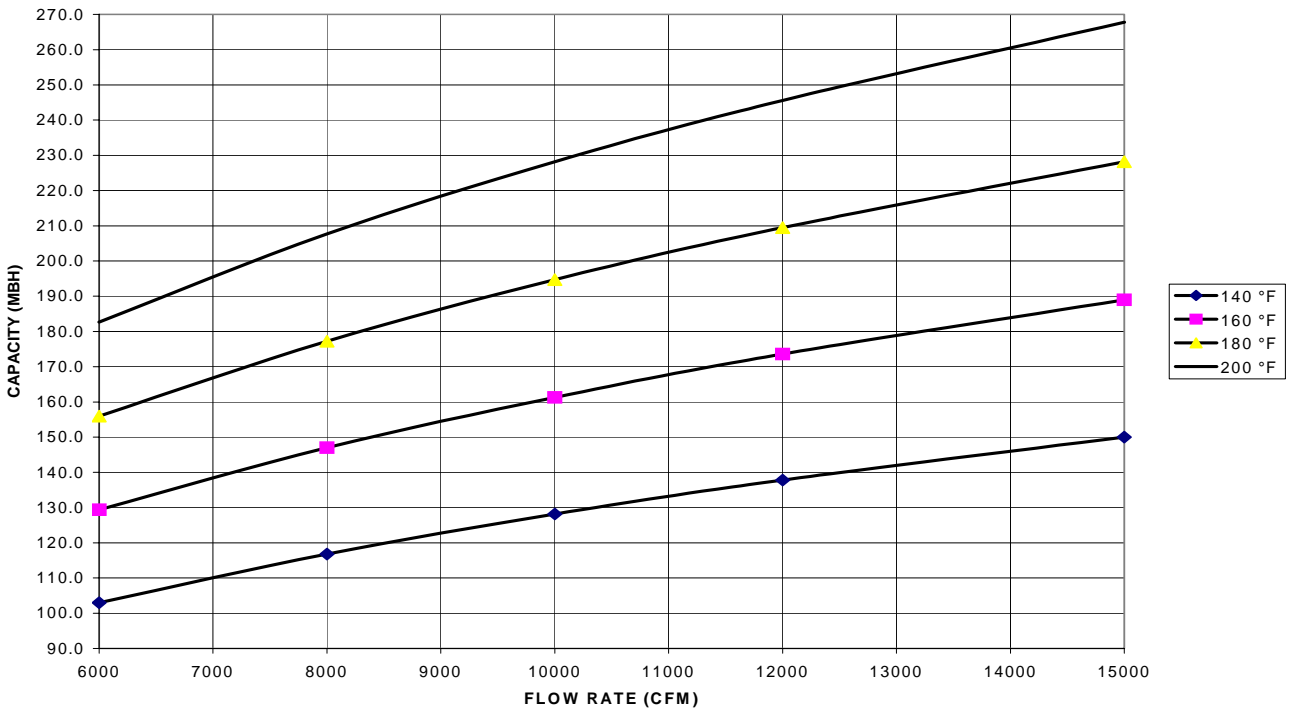

FIGURE 3 - HOT WATER COIL - 25 & 30 TON, 1 ROW, AT 20 GPM

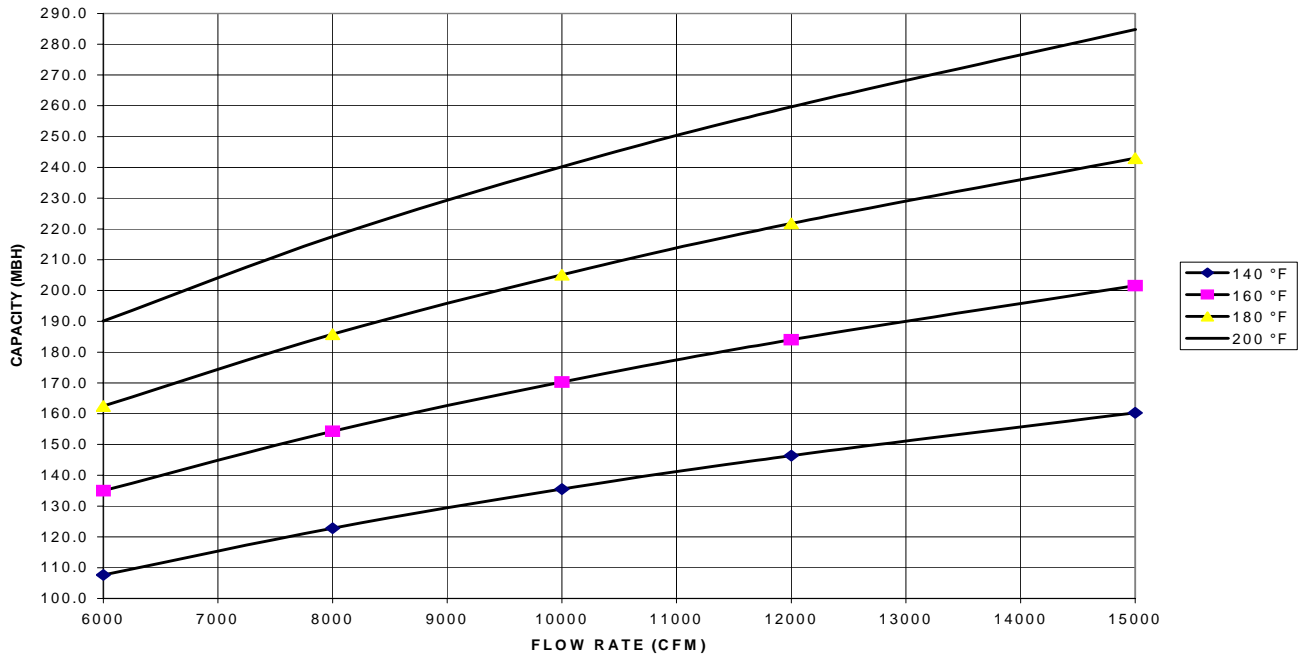

FIGURE 4 - HOT WATER COIL - 25 & 30 TON, 1 ROW, AT 30 GPM

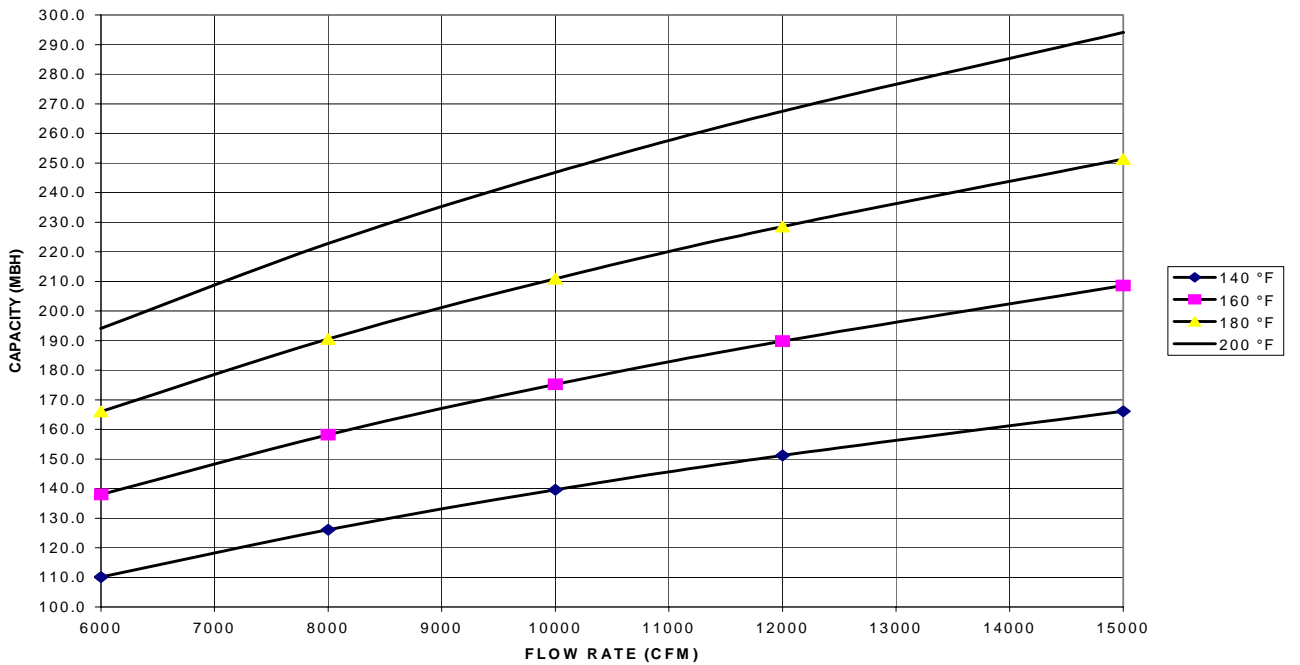

FIGURE 5 - HOT WATER COIL - 25 & 30 TON, 1 ROW AT 40 GPM

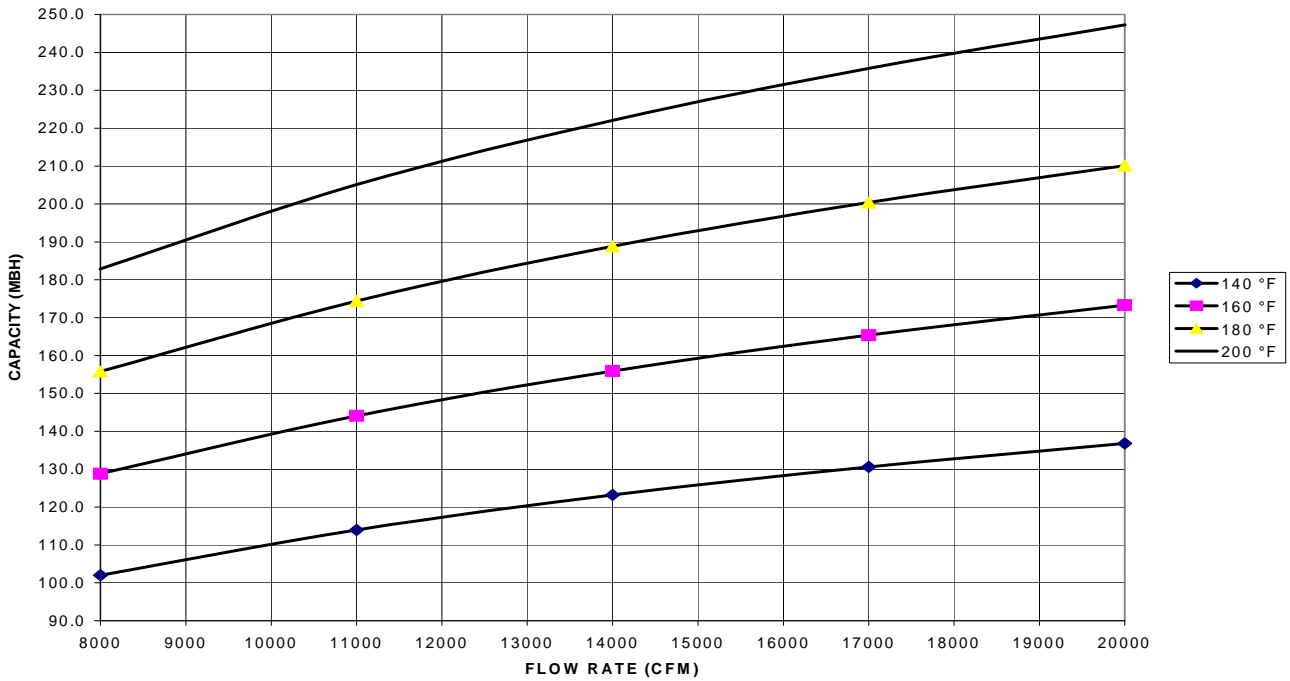

FIGURE 6 - HOT WATER COIL - 40 TON, 1 ROW, AT 10 GPM

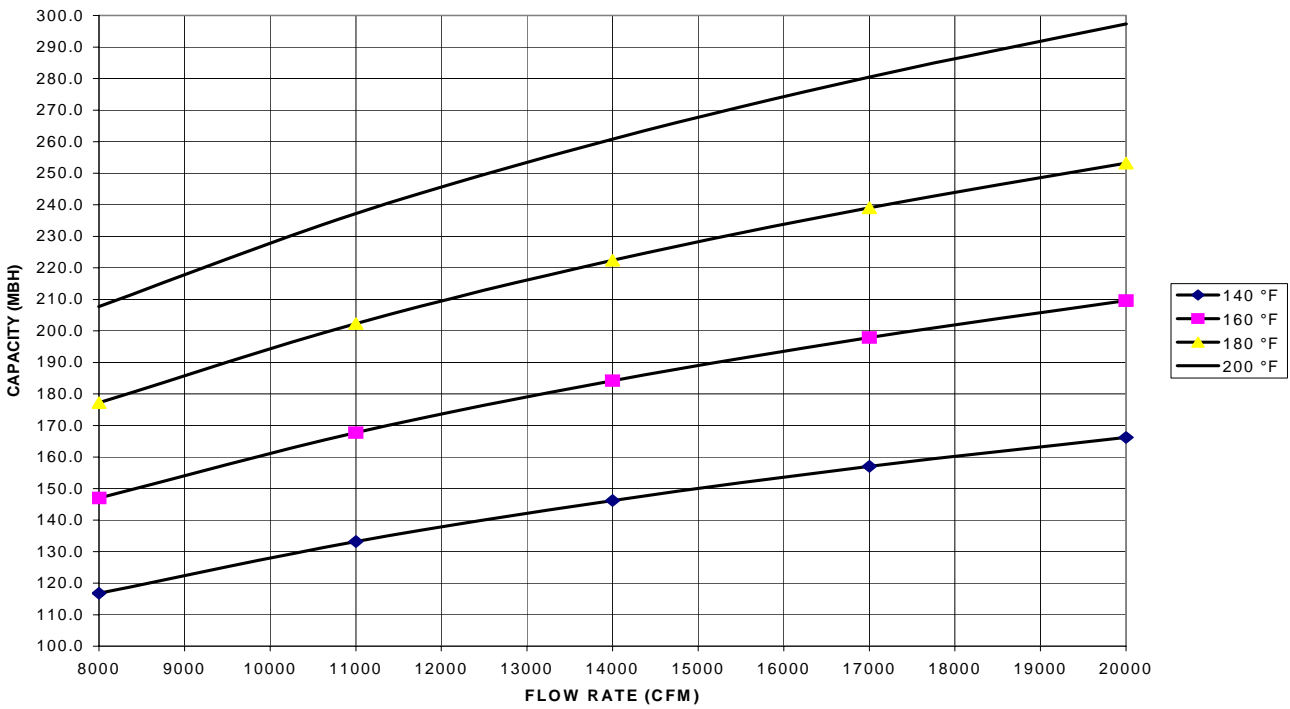

FIGURE 7 - HOT WATER COIL - 40 TON, 1 ROW, AT 20 GPM

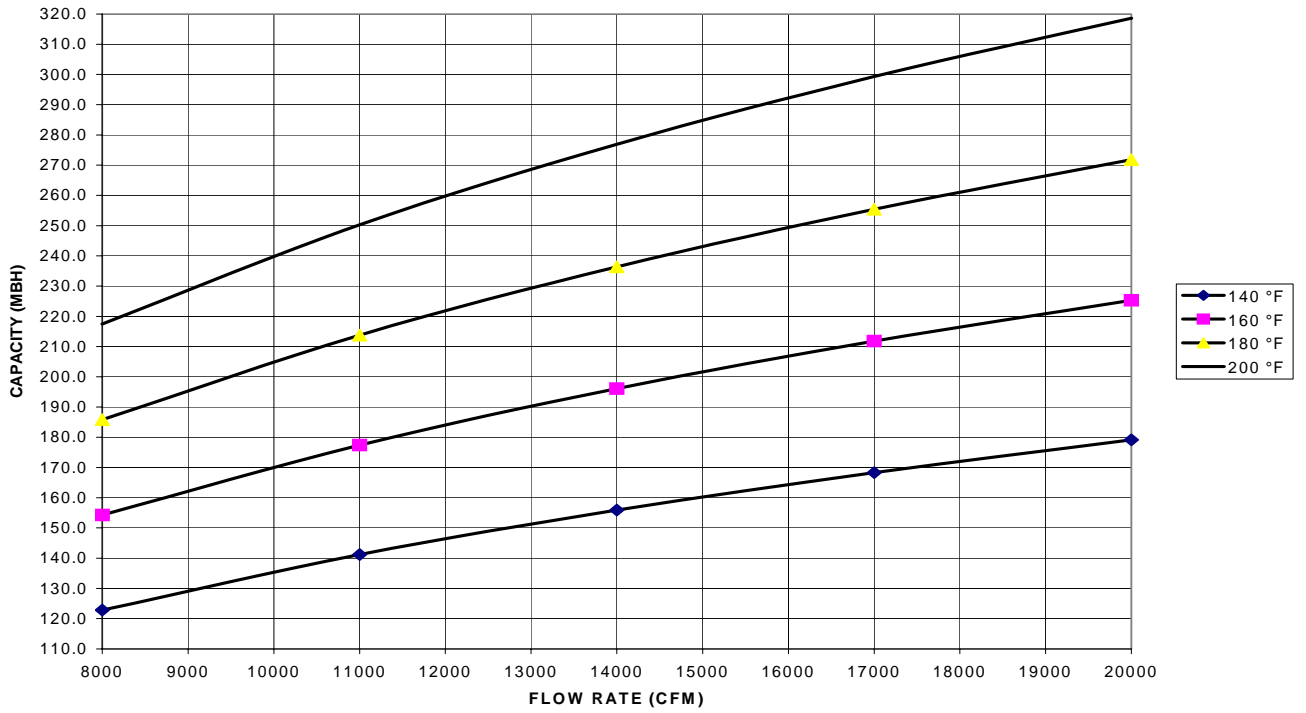

FIGURE 8 - HOT WATER COIL - 40 TON, 1 ROW, AT 30 GPM

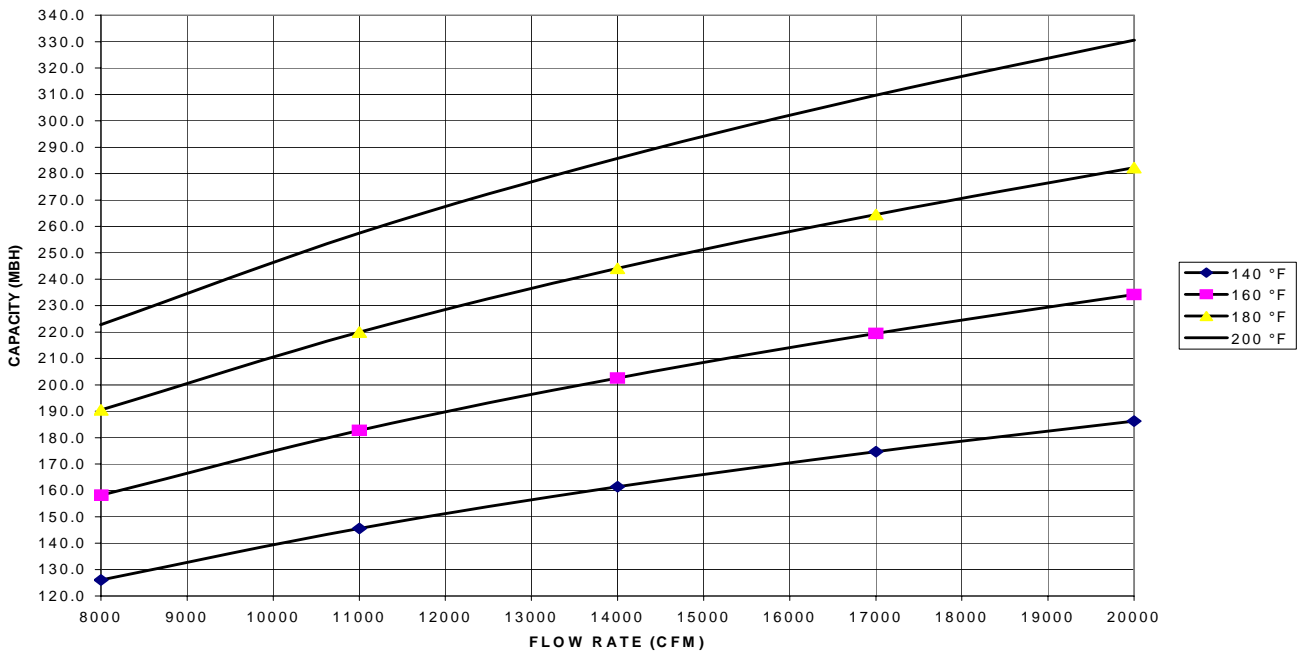

FIGURE 9 - HOT WATER COIL - 40 TON, 1 ROW, AT 40 GPM

PHYSICAL DATA HOT WATER COIL - 2 ROW

Coil Casing Galvanized Steel
 Coil Construction Al Fin / Cu. Tube
 Rows Deep 2
 Fin Thickness006"
 Tube Wall016"
 Tubes / Circuit 2
 Fins Per Inch 8
 Tubes High 22.50"
 Tube Length 65"
 Face Area 10.16 ft.²
 Weight 90 lbs
 Operating Weight 110 lbs

TABLE 10: WATER PRESSURE DROP (2 ROW, 25 & 30 TON)

GPM	20	40	60	80
WATER PRESSURE DROP	0.9	3.0	6.0	10.0

TABLE 11: STATIC RESISTANCE HOT WATER COIL (25 & 30 TON)

CFM	6000	8000	10000	15000
AIR PRESSURE DROP 1 Row	0.07	0.11	0.16	0.32
AIR PRESSURE DROP 2 Row	0.14	0.23	0.33	0.65

NOTE: Water pressure drop numbers are based on 60°F entering air temperature, 2.00" maximum air pressure drop across the hot water coil(s). ARI certified ratings at covering other conditions are available upon request. Hot water coils are approved for use with glycol (rates available upon request.)

TABLE 12: HOT WATER COIL (2 ROW, 25 & 30 TON)¹

GPM	CFM	CAPACITY (MBH) AT ENTERING WATER TEMPERATURE			
		140 °F	160 °F	180 °F	200 °F
20	6000	177.5	223.8	270.4	317.3
	8000	203.8	257.2	311.1	365.5
	10000	224.8	284.1	343.9	404.2
	12000	242.2	306.4	371.1	436.4
	15000	263.6	333.8	404.6	476.1
40	6000	198.1	248.9	300.0	351.3
	8000	232.2	292.0	352.2	412.7
	10000	260.7	328.1	395.9	464.1
	12000	285.0	359.0	433.4	508.3
	15000	316.0	398.4	481.3	564.8

TABLE 12: HOT WATER COIL (2 ROW, 25 & 30 TON)¹

GPM	CFM	CAPACITY (MBH) AT ENTERING WATER TEMPERATURE			
		140 °F	160 °F	180 °F	200 °F
60	6000	206.1	258.7	311.4	364.2
	8000	243.6	305.9	368.4	431.1
	10000	275.3	345.9	416.8	488.0
	12000	302.9	380.7	458.9	537.6
	15000	338.4	425.7	513.4	601.7
80	6000	210.5	263.9	317.4	371.1
	8000	249.8	313.3	377.1	441.1
	10000	283.3	355.6	428.2	501.0
	12000	312.7	392.7	473.0	553.6
	15000	351.0	440.9	531.3	622.1

1. Based on 60°F entering air temperature, 2.00" maximum pressure drop across the hot water coil

TABLE 13: HOT WATER COIL (2 ROWS, 40 TON)¹

GPM	CFM	CAPACITY (MBH) AT ENTERING WATER TEMPERATURE			
		140 °F	160 °F	180 °F	200 °F
20	8000	203.8	257.2	311.1	365.5
	11000	233.9	295.7	358.1	421.0
	14000	257.0	325.3	394.2	463.8
	17000	275.5	349.0	423.3	498.3
	20000	290.9	368.7	447.4	526.9
40	8000	232.2	292.0	352.2	412.7
	11000	273.3	344.1	415.3	487.0
	14000	306.3	386.0	466.3	547.1
	17000	333.9	421.1	508.9	597.3
	20000	357.5	451.1	545.4	640.5
60	8000	243.6	305.9	368.4	431.1
	11000	289.5	363.9	438.5	513.6
	14000	327.2	411.5	496.3	581.5
	17000	359.2	452.0	545.3	639.2
	20000	386.9	487.1	587.9	689.4
80	8000	249.8	313.3	377.1	441.1
	11000	298.5	374.7	451.2	528.1
	14000	338.9	425.7	512.8	600.5
	17000	373.4	469.3	565.6	662.5
	20000	403.6	507.5	611.8	716.8

1. Based on 60°F entering air temperature, 2.00" maximum air pressure drop across the hot water coil. ARI certified ratings at other conditions available upon request. Hot water coils are approved for use with glycol (ratings available upon request.)

TABLE 14: STATIC RESISTANCE HOT WATER COIL (40 TON)

CFM	8000	11000	14000	20000
AIR PRESSURE DROP 1 Row	0.11	0.19	0.29	0.52
AIR PRESSURE DROP 2 Row	0.23	0.39	0.58	1.06

TABLE 15: WATER PRESSURE DROP (2 ROW, 40 TON)

GPM	20	40	60	80
WATER PRESSURE DROP	0.9	3.0	6.0	10.0

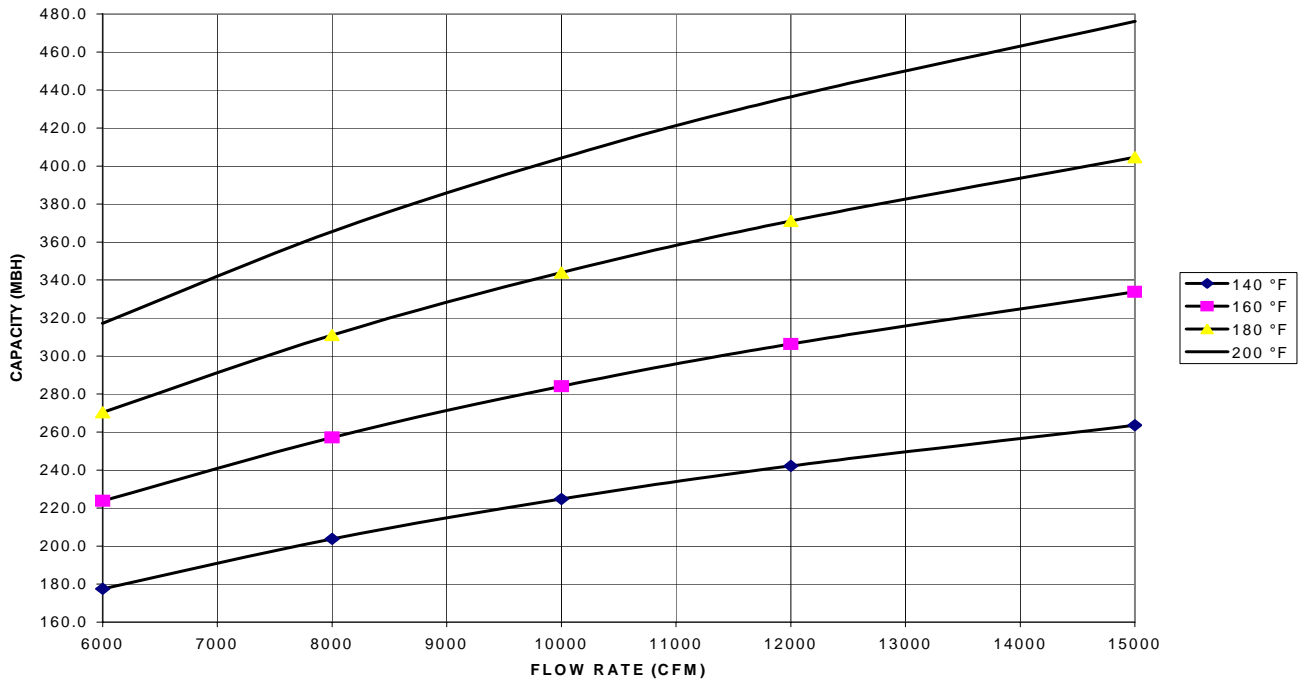

FIGURE 10 - HOT WATER COIL - 25 & 30 TON, 2 ROW, AT 20 GPM

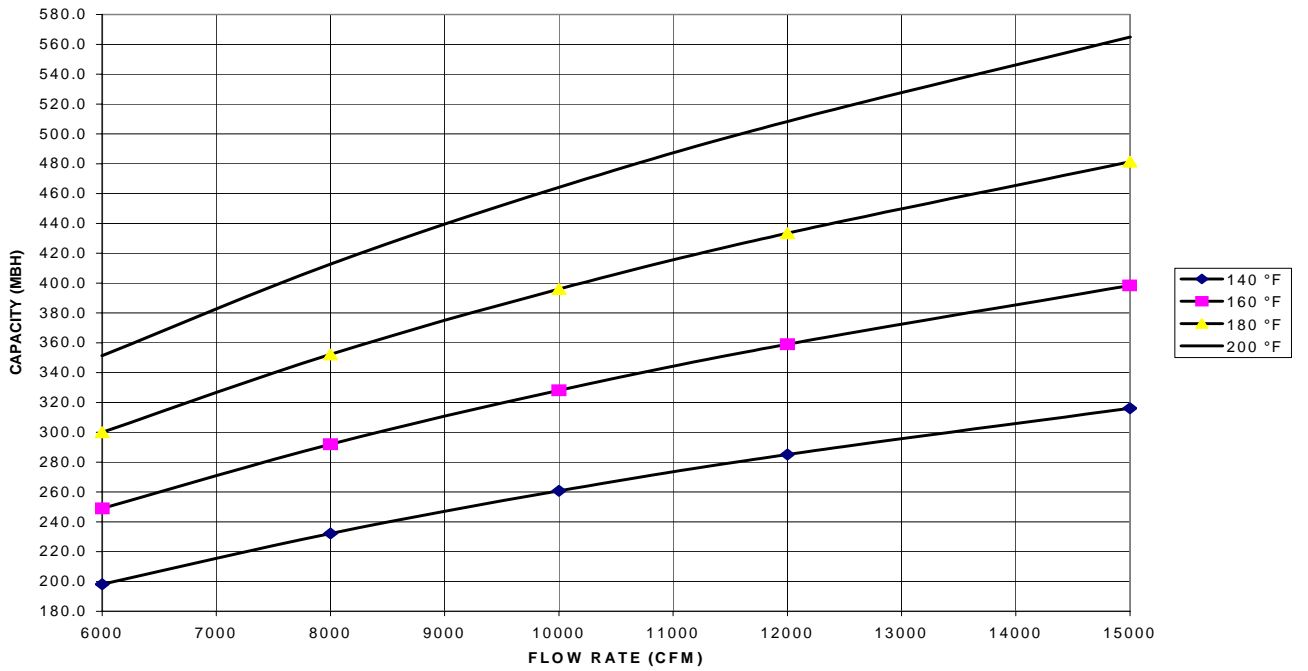

FIGURE 11 - HOT WATER COIL - 25 & 30 TON, 2 ROW, AT 40 GPM

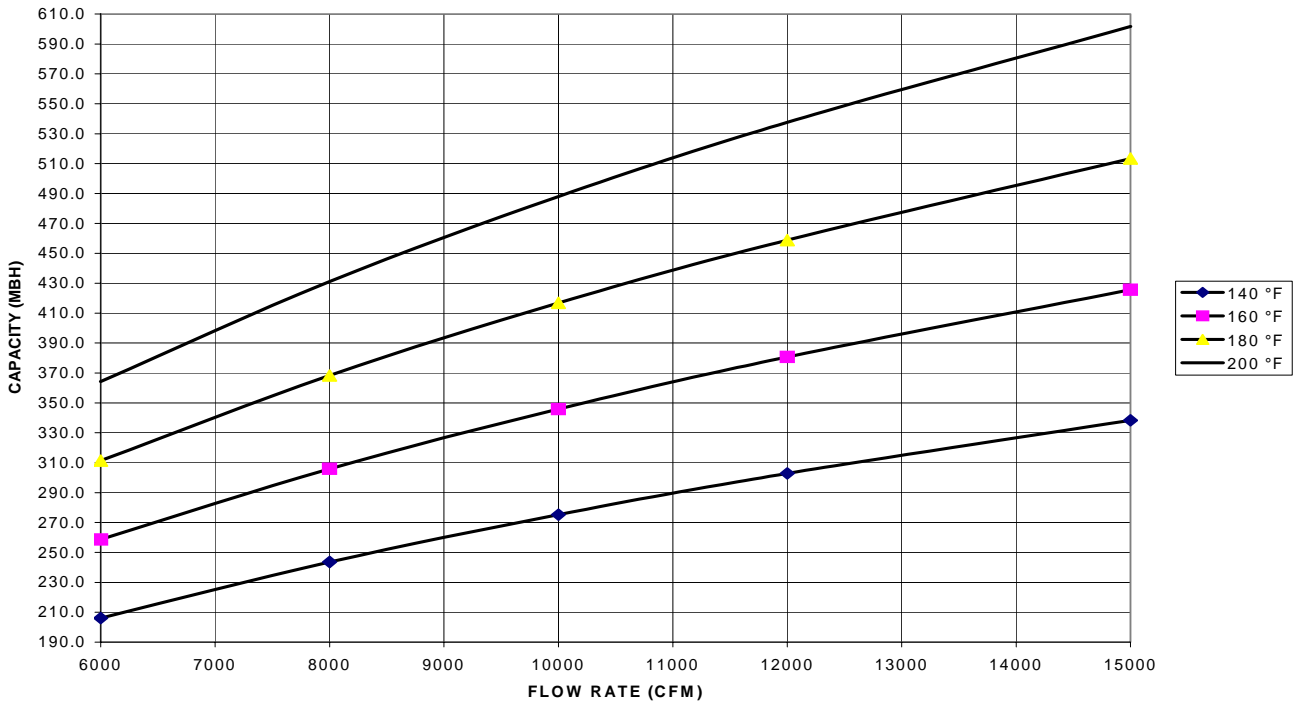

FIGURE 12 - HOT WATER COIL - 25 & 30 TON, 2 ROW, AT 60 GPM

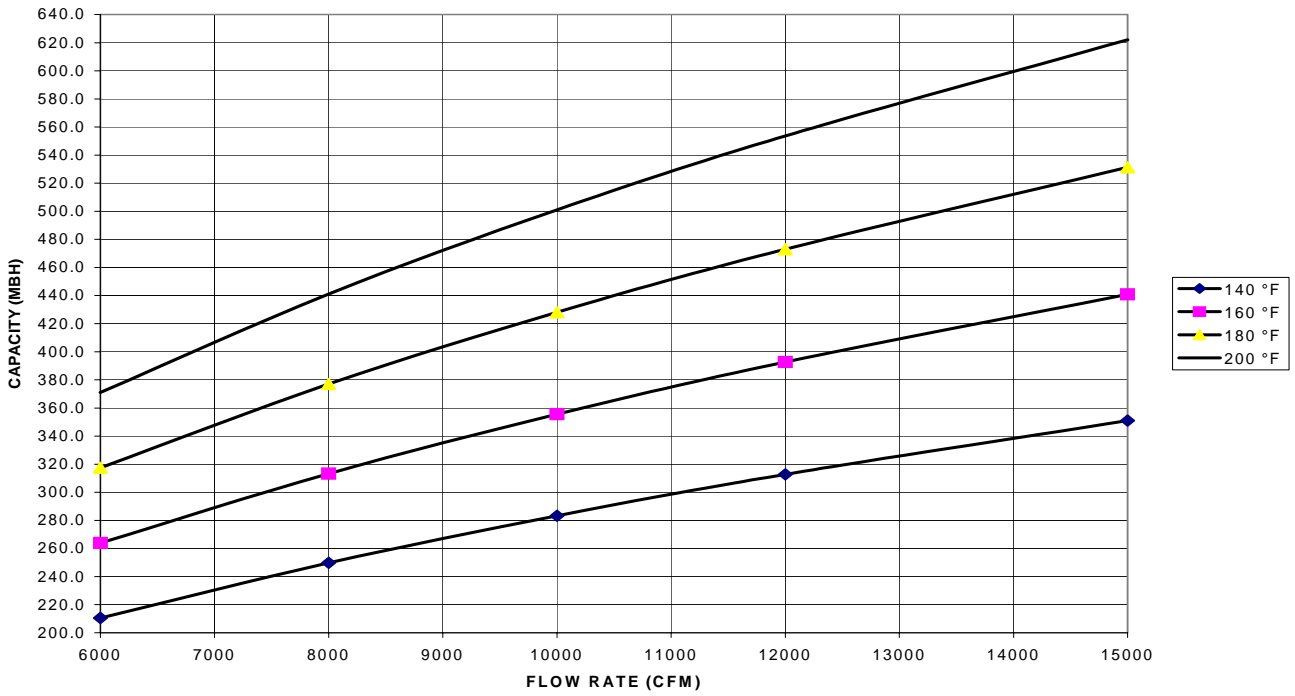

FIGURE 13 - HOT WATER COIL - 25 & 30 TON, 2 ROW, AT 80 GPM

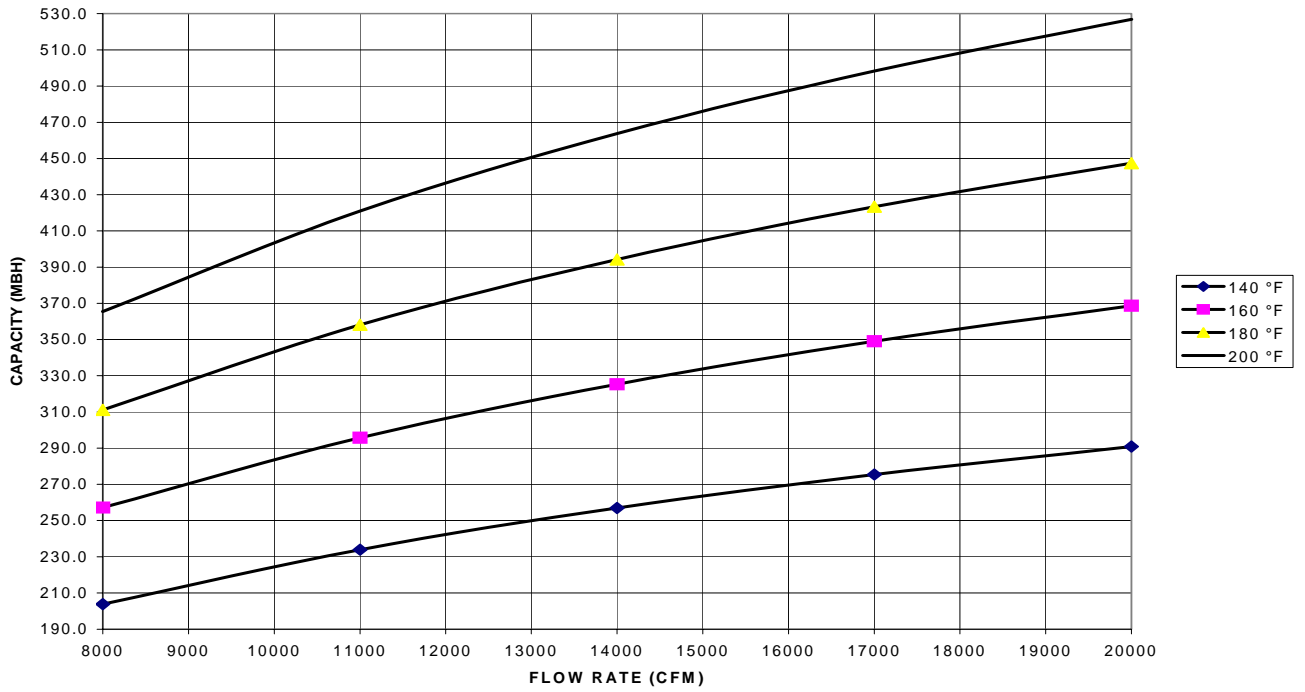

FIGURE 14 - HOT WATER COIL - 40 TON, 2 ROW, AT 20 GPM

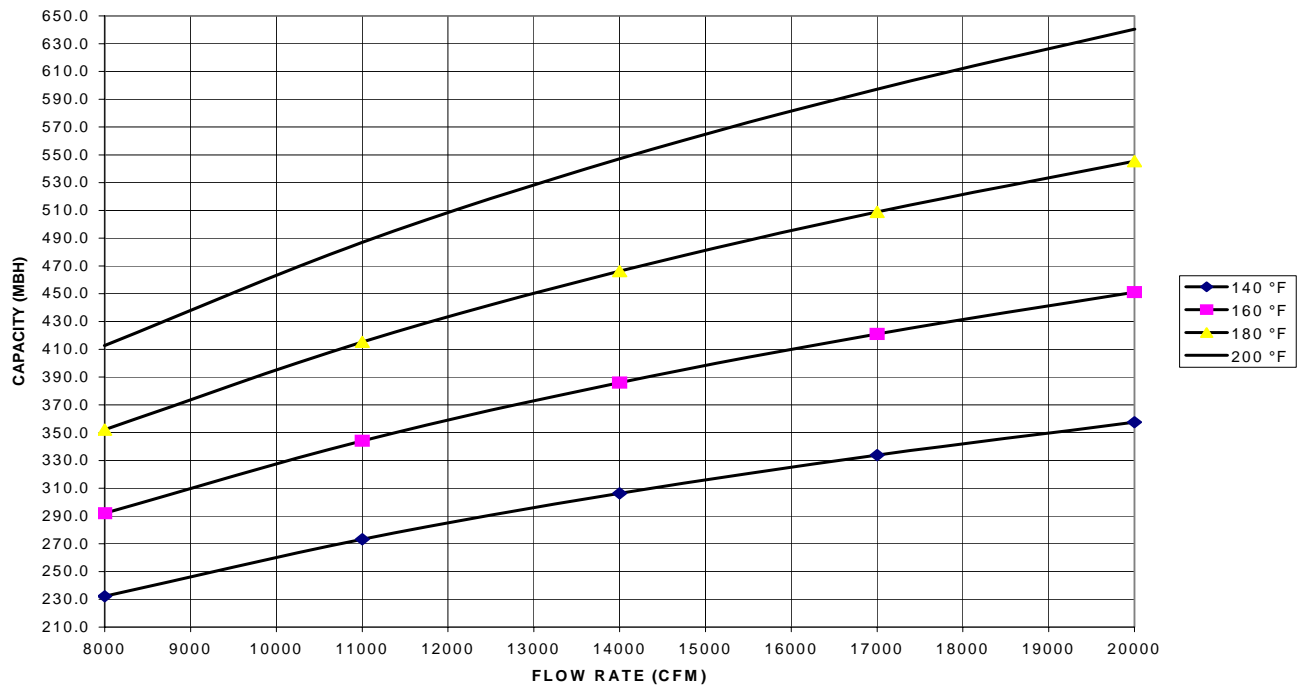

FIGURE 15 - HOT WATER COIL - 40 TON, 2 ROW, AT 40 GPM

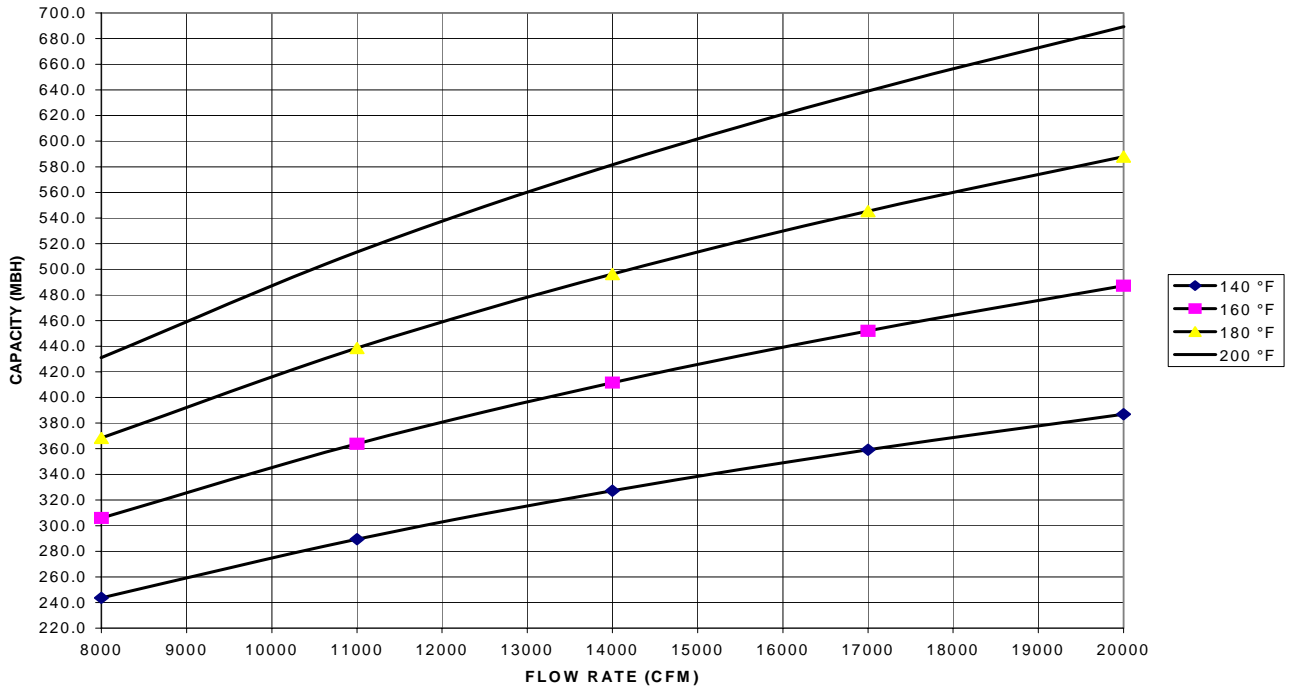

FIGURE 16 - HOT WATER COIL - 40 TON, 2 ROW, AT 60 GPM

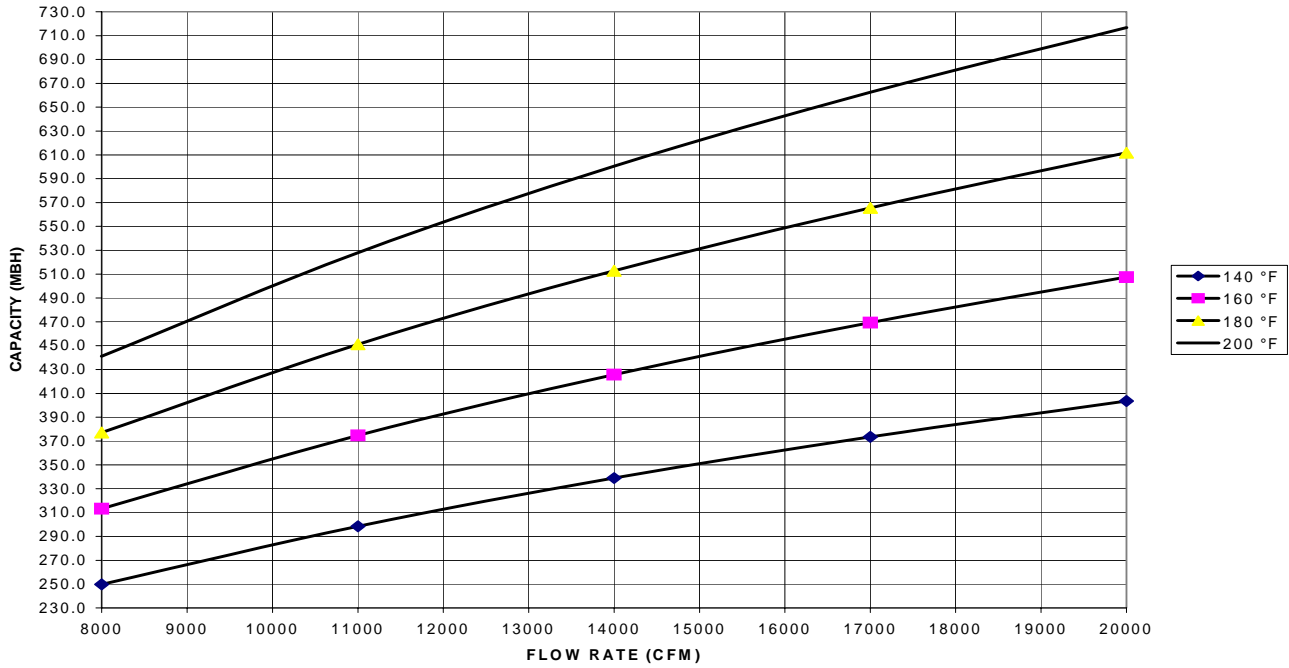

FIGURE 17 - HOT WATER COIL - 40 TON, 2 ROW, AT 80 GPM

STEAM HEATING

The YORK Millennium units (25, 30, and 40 ton sizes) can be manufactured with a steam heat coil (Bottom Supply only). YORK's one row steam coil is installed in the heating section just downstream of the supply air fan and just above the supply air opening in the bottom of the unit.

The steam control valve will not be provided. The installer will need to field supply a steam control valve. Connect the steam piping and valve power wiring at the job site for the steam heat section to be operational.

There are no provisions in the coil or control sequence to prevent freezing of condensate. The control valve, piping and field installed wiring connections are particularly vulnerable because they are installed in the vestibule outside of the conditioned air stream.

All piping, control valves, and wiring that is field installed must conform to all local and national codes

Condensate can freeze on the control valve and piping if they are not properly insulated.

PHYSICAL DATA STEAM COIL - 1 ROW

Coil Casing	Galvanized Steel
Coil Construction	Al Fin / Cu. Tube
Rows Deep	1
Fin Thickness010"
Tube Wall035"
Tubes / Circuit.	2
Fins Per Inch6
Tubes High	21"
Tube Length	65"
Face Area	9.48 ft. ²
Weight	92 lbs.

*Hot water, steam coil or electric heat not available for front or rear supply.

TABLE 16: STEAM COIL (1 ROW, 25 & 30 TON)¹

CFM	CAPACITY (MBH) AT STEAM PRESSURE (PSI)			
	2	6	10	15
6000	194.1	207.9	219.8	232.6
8000	221.1	236.9	250.4	265.0
10000	243.2	260.5	275.4	291.4
12000	261.9	280.6	296.6	313.9
15000	285.6	306.0	323.5	342.4

¹. Based on 60°F entering air temperature, 2.00" maximum air pressure drop across the coil.

TABLE 17: STATIC RESISTANCE STEAM COIL (1 ROW, 25 & 30 TON)

CFM	6000	8000	10000	12000	15000
AIR PRESSURE DROP	0.11	0.18	0.26	0.36	0.54

TABLE 18: STEAM COIL (1 ROW, 40 TON)¹

CFM	CAPACITY (MBH) AT STEAM PRESSURE (PSI)			
	2	6	10	15
8000	221.1	236.9	250.4	265.0
11000	252.9	271.0	286.4	303.1
14000	278.2	298.0	315.0	333.4
17000	299.4	320.7	339.0	358.8
20000	317.6	340.2	359.6	380.6

¹. Based on 60°F entering air temperature, 2.00" maximum air pressure drop across the coil.

TABLE 19: STATIC RESISTANCE STEAM COIL (1 ROW, 40 TON)

CFM	8000	11000	14000	17000	20000
AIR PRESSURE DROP	0.18	0.31	0.48	0.67	0.88

PIPING CONNECTIONS

The steam piping must enter the unit through the floor of the heat section compartment. The access doors to the compartment are gasketed to the compartment can be sealed. However, as added protection for condensate leakage into the space, the piping access holes should be sealed with a heat resistant mastic. The following figure illustrates the approximate location of the compartment and piping connections.

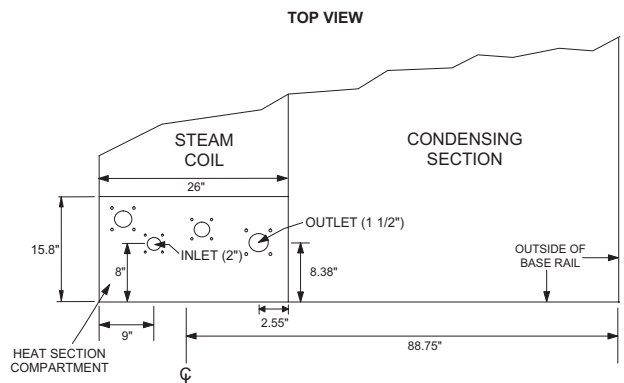

FIGURE 18 - STEAM PIPING CROSS SECTION

WARNING

DO NOT use tin based solder. Brazing with tin based solder could cause equipment damage or possible injury to OCCUPANTS of the structure that is being conditioned.

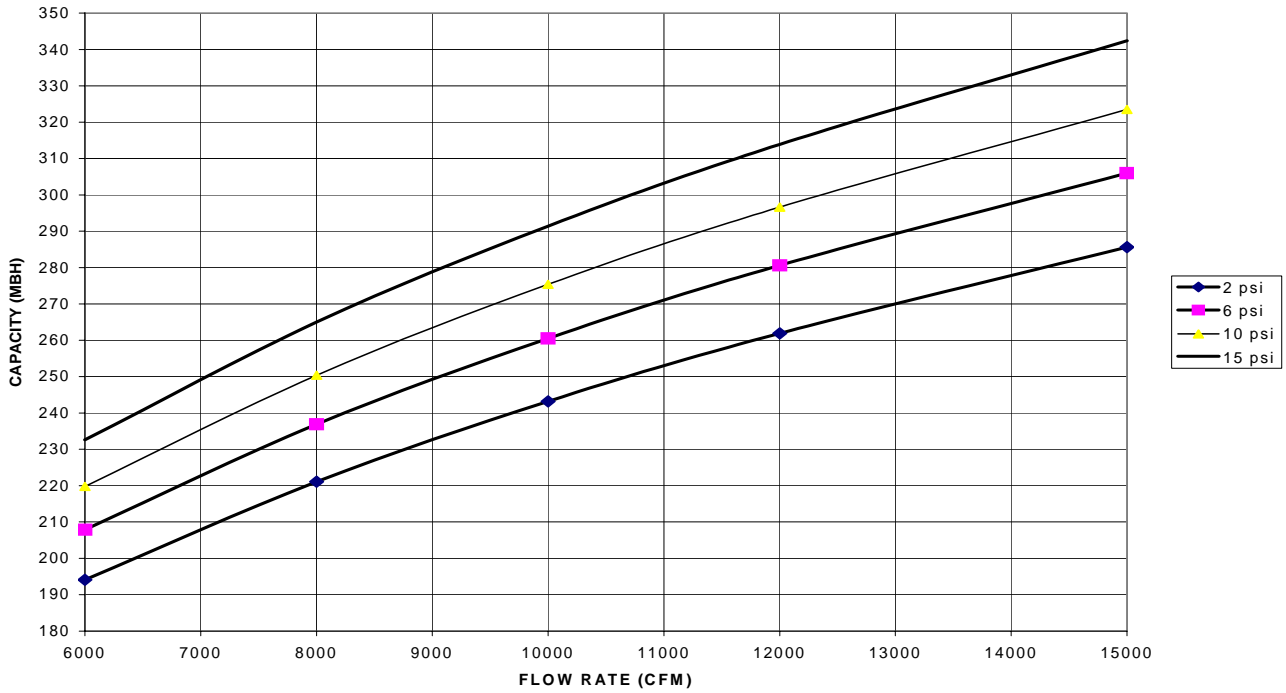

FIGURE 19 - STEAM COIL - 25 & 30 TON, 1 ROW

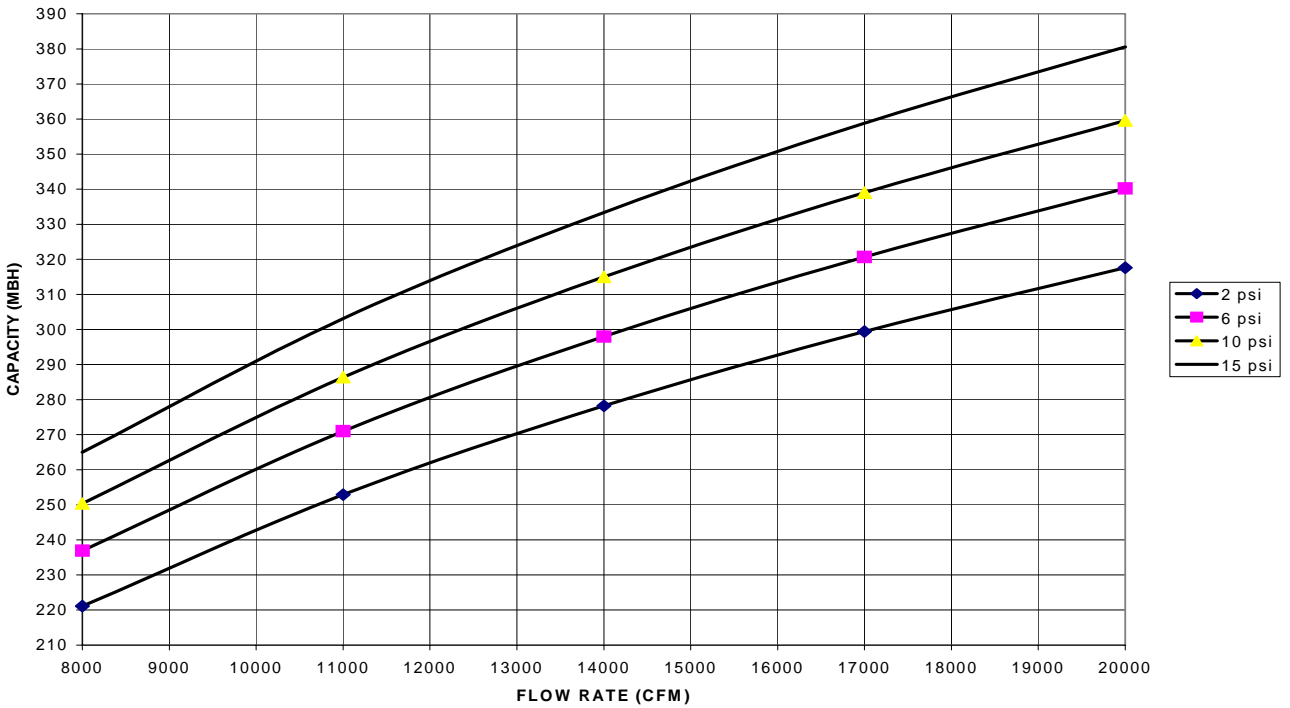

FIGURE 20 - STEAM COIL - 40 TON, 1 ROW

TABLE 20: EXHAUST FAN DRIVE DATA

MODEL	BLOWER RPM RANGE	MOTOR				MOTOR PULLEY		BLOWER PULLEY		BELTS	
		HP	FRAME SIZE	MOTOR EFF (STD. MOTOR)	MOTOR EFF (HI EFF OPT)	PITCH DIA (INCHES)	BORE (INCHES)	PITCH DIA (INCHES)	BORE (INCHES)	DESIGNATION	QTY
25 Ton	732	5	213T	87.5	89.5	4.9	1-3/8	11.3	2-3/16	BX63	2
	827	7.5	215T	88.5	91.7	5.5	1-3/8	11.3	2-3/16	BX63	2
	955	10	215T	89.5	91	6.3	1-5/8	11.3	2-3/16	BX63	2
30 Ton	852	7.5	213T	84	86.5	5.5	1-3/8	11.3	1-11/16	B65	2
	976	10	215T	86.5	89.5	6.3	1-3/8	11.3	1-11/16	B65	2
	1069	15	254T	85.7	89.5	6.9	1-3/8	11.3	1-11/16	B65	2
40 Ton	852	7.5	184T	84	86.5	5.5	1-3/8	11.3	1-11/16	B65	2
	976	10	215T	86.5	89.5	6.3	1-3/8	11.3	1-11/16	B65	2
	1069	15	254T	85.7	89.5	6.5	1-3/8	11.3	1-11/16	B65	2

TABLE 21: SUPPLY FAN MOTOR AND DRIVE DATA¹

MODEL	BLOWER RPM RANGE	MOTOR				MOTOR PULLEY		BLOWER PULLEY		BELTS	
		HP	FRAME SIZE	MOTOR EFFICIENCY (STD. MOTOR)	MOTOR EFFICIENCY (ULTRA HI EFF OPT)	PITCH DIA (INCHES)	BORE (INCHES)	PITCH DIA (INCHES)	BORE (INCHES)	DESIGNATION	QTY
25 Ton	567	7.5	213t	88.5	91.7	4.5	1-3/8	13.9	2-3/16	BX56	2
	692	10	215T	89.5	91	5.5	1-3/8	13.9	2-3/16	BX56	2
	793	15	254T	91	91.7	6.3	1-5/8	13.9	2-3/16	BX56	2
	894	20	256T	91	93	7.1	1-5/8	13.9	2-3/16	BX56	2
30 Ton	617	10	215T	89.5	91	4.9	1-3/8	13.9	2-3/16	BX56	2
	743	15	254T	91	91.7	5.9	1-5/8	13.9	2-3/16	BX56	2
	844	20	256T	91	93	6.7	1-5/8	13.7	2-3/16	5VX610	2
40 Ton	919	25	284T	91.7	93.6	7.1	1-7/8	13.7	2-3/16	5VX610	2
	567	10	215T	89.5	91	4.5	1-3/8	13.9	2-7/16	BX67	2
	642	15	254T	91	91.7	5.1	1-5/8	13.7	2-7/16	5VX710	2
	717	20	256T	91	93	5.7	1-5/8	13.7	2-7/16	5VX710	2
	768	25	284T	91.7	93.6	6.1	1-7/8	13.7	2-7/16	5VX710	2

¹. kW = (BHP X 0.746) / Motor Eff.
MBH = kW X 3.414
MBH = (BHP X 2.546) / Motor Eff.

SUPPLY AIR DRIVE ADJUSTMENT

At unit start-up, the measured CFM may be higher or lower than the specified CFM shown in Figures 22, 23, and 24. To achieve the specified CFM, the speed of the drive may have to be decreased or increased by changing the pitch diameter (PD) of the motor sheave as outlined below:

$$\frac{\text{Specified CFM}}{\text{Measured CFM}} \bullet \text{PD of Standard Sheave} = \text{PD of New Sheave}$$

⚠ WARNING

Failure to properly adjust the total system air quantity can result in extensive blower damage.

⚠ CAUTION

Before making any blower speed changes review the installation for any installation errors, leaks or undesirable systems effects that can result in loss of air flow.

⚠ CAUTION

Even small changes in blower speed can result in substantial changes in static pressure and bhp. Bhp or amp draw of the blower motor will increase (see table) by the cube ratio of the blower speed. Static pressure will increase by the square ratio of the blower speed. Tables 24 and 25 are for reference only. All blower speed changes must be made by qualified personnel with strict adherence to the fan laws.

Example:

A 30-ton unit was selected to deliver 12,000 CFM with a 20 HP motor and a 966 RPM drive, but the unit is only delivering 11,000 CFM per Figures 22, 23, and 24.

Use the equation to determine the required PD for the new motor sheave $(12,000 \text{ CFM} / 11,000 \text{ CFM}) \times 6.9" = 7.53"$

Use the 30-ton table to select a Browning 2B5V74 which will increase the speed of the unit's drive and its supply air CFM 108.7%.

$$\text{New drive speed} = 1.087 \times 966 = 1,050 \text{ RPM}$$

$$\text{New supply air} = 1.087 \times 11,000 = 11,957 \text{ CFM}$$

Re-use the existing belts and blower sheave.

$$\text{New motor BHP} = (\text{speed increase})^3 \times \text{estimated motor BHP at original start-up with 11,000 CFM and 966 RPM} = (1.087)^3 \times 13.5 \text{ BHP} = 1.284 \times 13.5 \text{ BHP} = 17.3 \text{ BHP}$$

$$\text{New motor amps} = (\text{speed increase})^3 \times \text{measured motor amps at original start-up with 11,000 CFM and 966 RPM.}$$

TABLE 22: 25 TON DRIVE ADJUSTMENT

7.5 HP MOTOR & 567 RPM DRIVE			10 HP MOTOR & 692 RPM DRIVE			15 HP MOTOR & 793 RPM DRIVE			20 HP MOTOR & 894 RPM DRIVE		
%RPM & CFM	REQ'D PD	BROWNING 2B5V__	%RPM & CFM	REQ'D PD	BROWNING 2B5V__	%RPM & CFM	REQ'D PD	BROWNING 2B5V__	%RPM & CFM	REQ'D PD	BROWNING 2B5V__
-	-	-	82	4.5	42	84	5.3	50	86	6.1	58
-	-	-	86	4.7	44	87	5.5	52	89	6.3	60
100	(Std.)4.5	42	89	4.9	46	90	5.7	54	91	6.5	62
104	4.7	44	93	5.1	48	94	5.9	56	94	6.7	64
109	4.9	46	96	5.3	50	97	6.1	58	97	6.9	66
113	5.1	48	100	(Std.)5.5	52	100	(Std.)6.3	60	100	(Std.)7.1	68
118	5.3	50	104	5.7	54	103	6.5	62	103	7.3	70
122	5.5	52	107	5.9	56	106	6.7	64	108	7.7	74
126	5.7	54	111	6.1	58	110	6.9	66	117	8.3	80
-	-	-	115	6.3	60	113	7.1	68	125	8.9	86
-	-	-	118	6.5	62	116	7.3	70	-	-	-
-	-	-	122	6.7	64	122	7.7	74	-	-	-

TABLE 23: 30 TON DRIVE ADJUSTMENT

10 HP MOTOR & 617 RPM DRIVE			15 HP MOTOR & 743 RPM DRIVE			20 HP MOTOR & 856 RPM DRIVE			"25 HP MOTOR & 933 RPM DRIVE"		
%RPM & CFM	REQ'D PD	BROWNING 2B5V__	%RPM & CFM	REQ'D PD	BROWNING 2B5V__	%RPM & CFM	REQ'D PD	BROWNING 2B5V__	%RPM & CFM	REQ'D PD	BROWNING 2B5V__
91.8	4.5	42	86.4	5.1	48	82.1	5.5	54	86.3	6.1	60
95.9	4.7	44	89.8	5.3	50	85.1	5.7	56	89.0	6.3	62
100.0	(Std.) 4.9	46	93.2	5.5	52	88.1	5.9	58	91.8	6.5	64
104.1	5.1	48	96.6	5.7	54	91.0	6.1	60	94.5	6.7	66
108.2	5.3	50	100.0	(Std.) 5.9	56	94.0	6.3	62	97.3	6.9	68
112.2	5.5	52	103.4	6.1	58	97.0	6.5	64	100.0	(Std.) 7.1	70
116.3	5.7	54	106.8	6.3	60	100.0	(Std.) 6.7	66	105.5	7.5	74
120.4	5.9	56	110.2	6.5	62	103.0	6.9	68	113.7	8.1	80
124.5	6.1	58	113.6	6.7	64	106.0	7.1	70	121.9	8.7	86
-	-	-	116.9	6.9	66	109.0	7.5	74	-	-	-
-	-	-	120.3	7.1	68	114.9	8.1	80	-	-	-
-	-	-	123.7	7.3	70	123.9	8.7	86	-	-	-

TABLE 24: 40 TON DRIVE ADJUSTMENT

10 HP MOTOR & 667 RPM DRIVE			15 HP MOTOR & 768 RPM DRIVE			20 HP MOTOR & 830 RPM DRIVE			25 HP MOTOR & 881 RPM DRIVE		
%RPM & CFM	REQ'D PD	BROWNING 2B5V__	%RPM & CFM	REQ'D PD	BROWNING 2B5V__	%RPM & CFM	REQ'D PD	BROWNING 2B5V__	%RPM & CFM	REQ'D PD	BROWNING 2B5V__
100.0	4.5	42	88.2	4.5	44	82.5	4.7	46	83.7	5.1	50
104.4	4.7	44	92.1	4.7	46	86.0	4.9	48	86.9	5.3	52
108.9	(Std.) 4.9	46	96.0	4.9	48	89.5	5.1	50	90.2	5.5	54
113.3	5.1	48	100.0	(Std.) 5.1	50	93.0	5.3	52	93.4	5.7	56
117.8	5.3	50	103.9	5.3	52	96.5	5.5	54	96.7	5.9	58
122.2	5.5	52	107.8	5.5	54	100.0	5.7	56	100.0	(Std.) 6.1	60
126.7	5.7	54	111.7	5.7	56	103.5	5.9	58	103.3	6.3	62
-	-	-	115.6	5.9	58	107.0	6.1	60	106.6	6.5	64
-	-	-	119.5	6.1	60	110.5	6.3	62	109.8	6.7	66
-	-	-	123.4	6.3	62	114.0	6.5	64	113.1	6.9	68
-	-	-	127.4	6.5	64	117.5	6.7	66	116.4	7.1	70
-	-	-	-	-	66	121.1	6.9	68	119.7	7.5	74

TABLE 25: DRIVE ADJUSTMENT FOR POWER EXHAUST - 25 TON

5 HP MOTOR & 732 RPM DRIVE			7.5 HP MOTOR & 827 RPM DRIVE			10 HP MOTOR & 955 RPM DRIVE		
%RPM & CFM	REQ'D PD	BROWNING 2B5V__	%RPM & CFM	REQ'D PD	BROWNING 2B5V__	%RPM & CFM	REQ'D PD	BROWNING 2B5V__
100	4.9	46	92	5.1	48	93	5.9	56
104	5.1	48	96	5.3	50	97	6.1	58
109	5.3	50	100	5.5	52	100	6.3	60
113	5.5	52	104	5.7	54	103	6.5	62
117	5.7	54	108	5.9	56	107	6.7	64
122	5.9	56	112	6.1	58	110	6.9	66

TABLE 26: DRIVE ADJUSTMENT FOR POWER EXHAUST - 30 & 40 TON

7.5 HP MOTOR & 852 RPM DRIVE			10 HP MOTOR & 976 RPM DRIVE			15 HP MOTOR & 1069 RPM DRIVE		
% RPM & CFM	REQ'D PD (IN)	BROWNING 2B5V__	% RPM & CFM	REQ'D PD (IN)	BROWNING 2B5V__	% RPM & CFM	REQ'D PD (IN)	BROWNING 2B5V__
96.4	5.3	52	93.7	5.9	58	94.2	6.5	64
100.0	(Std.) 5.5	54	96.8	6.1	60	97.1	6.7	66
103.6	5.7	56	100.0	(Std.) 6.3	62	100.0	(Std.) 6.9	68
107.3	5.9	58	103.2	6.5	64	102.9	7.1	70
110.9	6.1	60	106.3	6.7	66	108.7	7.5	74
114.5	6.3	62	109.5	6.9	68	117.4	8.1	80

TABLE 27: COOLING PERFORMANCE - 25 TON STANDARD CAPACITY COIL

AIR ON EVAPORATOR COIL		85 °F AIR ON CONDENSER COIL																
		POWER INPUT KW	CAPACITY (MBH) AT ENTERING DRY BULB (F)															
			90		86		83		80		77		74		71		68	
CFM	WB°F	TOT	SEN	TOT	SEN	TOT	SEN	TOT	SEN	TOT	SEN	TOT	SEN	TOT	SEN	TOT	SEN	
6000	75	25.8	350	208	348	181	346	160	344	139	341	118	---	---	---	---	---	---
	72	25.5	335	229	333	203	332	183	330	162	328	141	325	120	---	---	---	---
	67	25.0	310	263	309	238	308	217	307	198	306	179	304	159	302	138	299	116
	62	24.6	299	299	288	272	286	253	284	232	283	213	282	194	280	175	279	154
	57	24.4	299	299	288	288	279	279	272	272	263	247	261	227	260	207	258	188
7000	75	26.0	360	223	358	193	356	170	354	145	350	120	---	---	---	---	---	---
	72	25.7	345	247	343	217	342	195	340	172	338	148	334	123	---	---	---	---
	67	25.2	323	288	319	257	318	235	317	211	315	191	313	167	311	143	308	118
	62	24.8	317	317	300	297	297	275	294	251	293	229	291	207	290	185	288	163
57	24.6	317	317	305	305	296	296	287	287	274	268	272	246	269	223	268	200	
8000	75	26.1	368	237	366	203	364	179	361	151	357	123	---	---	---	---	---	---
	72	25.8	353	264	351	230	350	205	348	181	345	154	341	126	---	---	---	---
	67	25.3	332	310	329	277	326	251	325	224	323	200	320	175	318	148	315	120
	62	25.0	333	333	320	320	306	295	304	270	300	244	299	219	297	194	295	169
	57	24.9	332	332	319	319	310	310	300	300	291	291	280	263	276	237	275	212
9000	75	26.2	375	251	372	213	370	186	367	157	363	126	---	---	---	---	---	---
	72	25.9	360	281	358	243	356	215	353	188	351	160	347	128	---	---	---	---
	67	25.5	341	333	336	295	332	265	331	236	329	209	326	182	323	153	319	121
	62	25.2	345	345	332	332	321	321	311	287	307	258	305	230	303	202	301	175
	57	25.1	345	345	332	332	321	321	311	311	301	301	287	280	284	252	281	222
10000	75	26.3	380	264	377	223	375	193	372	163	367	128	---	---	---	---	---	---
	72	26.1	367	300	363	256	361	225	358	195	356	165	351	131	---	---	---	---
	67	25.6	356	356	342	312	337	279	336	247	334	218	331	188	328	158	324	123
	62	25.3	356	356	342	342	331	331	317	304	314	273	310	241	308	210	306	180
	57	25.2	356	356	342	342	331	331	321	321	311	311	301	301	289	264	285	232
11000	75	26.4	384	277	382	232	379	199	376	167	371	130	---	---	---	---	---	---
	72	26.1	372	315	367	268	365	234	362	201	359	169	355	133	---	---	---	---
	67	25.7	366	366	347	328	344	296	341	258	338	226	335	193	332	162	327	124
	62	25.5	366	366	351	351	340	340	329	329	318	286	314	251	312	218	309	185
	57	25.4	366	366	351	351	340	340	329	329	318	318	308	308	294	276	289	242
12000	75	26.5	388	290	385	241	383	205	379	171	373	133	---	---	---	---	---	---
	72	26.2	377	331	371	280	369	243	366	208	363	173	358	135	---	---	---	---
	67	25.8	374	374	353	346	348	309	344	269	341	234	338	199	335	165	330	125
	62	25.6	374	374	359	359	348	348	336	336	322	298	317	261	315	225	312	190
	57	25.5	374	374	359	359	347	347	336	336	325	325	314	314	299	289	293	251
13000	75	26.5	391	303	388	250	385	211	382	175	377	135	---	---	---	---	---	---
	72	26.2	381	345	374	291	372	252	369	214	365	176	360	137	---	---	---	---
	67	25.9	382	382	366	366	352	321	347	279	344	242	341	204	337	167	330	126
	62	25.7	381	381	366	366	354	354	343	343	326	310	320	271	318	232	315	194
	57	25.6	381	381	366	366	354	354	342	342	331	331	320	320	303	299	297	262

TABLE 27: COOLING PERFORMANCE - 25 TON STANDARD CAPACITY COIL (CONTINUED)

AIR ON EVAPORATOR COIL		95 °F AIR ON CONDENSER COIL																
		POWER INPUT KW	CAPACITY (MBH) AT ENTERING DRY BULB (F)															
			90		86		83		80		77		74		71		68	
CFM	WB°F	TOT	SEN	TOT	SEN	TOT	SEN	TOT	SEN	TOT	SEN	TOT	SEN	TOT	SEN	TOT	SEN	
6000	75	28.4	337	202	335	176	333	155	331	134	328	113	---	---	---	---	---	---
	72	28.1	322	223	321	197	320	178	318	157	315	136	313	115	---	---	---	---
	67	27.6	300	259	298	232	297	212	296	192	294	174	293	154	290	133	288	112
	62	27.2	291	291	278	266	276	247	274	227	273	208	272	189	271	171	269	149
	57	27.0	290	290	279	279	271	271	263	263	254	242	252	222	251	203	250	184
7000	75	28.6	347	217	345	188	342	165	340	140	336	116	---	---	---	---	---	---
	72	28.3	332	241	330	211	329	189	327	167	324	143	321	118	---	---	---	---
	67	27.8	311	282	307	251	306	229	305	205	303	184	302	163	299	138	296	113
	62	27.4	308	308	296	296	286	269	284	247	282	223	281	201	279	179	277	157
	57	27.2	308	308	296	296	287	287	278	278	265	263	262	241	259	218	258	196
8000	75	28.7	354	232	352	198	350	174	347	146	343	118	---	---	---	---	---	---
	72	28.5	340	259	338	225	336	200	334	175	331	149	328	121	---	---	---	---
	67	27.9	320	304	316	271	313	244	312	218	310	194	308	169	306	143	302	115
	62	27.6	322	322	309	309	295	290	292	264	289	238	288	213	286	188	284	163
	57	27.5	322	322	309	309	300	300	291	291	281	281	270	257	266	232	265	207
9000	75	28.9	360	245	357	208	355	181	352	152	348	121	---	---	---	---	---	---
	72	28.6	346	276	344	237	342	210	339	183	337	155	333	123	---	---	---	---
	67	28.1	334	334	323	289	319	259	318	230	316	203	314	176	311	148	307	116
	62	27.8	334	334	321	321	311	311	299	281	296	254	293	224	291	196	289	169
	57	27.7	334	334	321	321	311	311	301	301	291	291	277	273	273	246	270	217
10000	75	28.9	365	259	362	217	359	187	356	158	352	123	---	---	---	---	---	---
	72	28.7	353	294	348	250	346	219	344	189	341	160	337	126	---	---	---	---
	67	28.2	345	345	329	306	326	276	323	241	320	212	318	181	315	152	310	118
	62	28.0	345	345	331	331	320	320	305	298	301	267	298	235	296	204	293	174
	57	27.9	344	344	330	330	320	320	310	310	300	300	290	290	278	258	274	227
11000	75	29.1	369	271	366	226	363	194	360	162	355	126	---	---	---	---	---	---
	72	28.8	358	309	352	262	350	228	348	195	344	163	340	128	---	---	---	---
	67	28.3	354	354	335	324	331	289	327	252	324	220	321	188	318	156	314	119
	62	28.1	353	353	339	339	328	328	318	318	306	280	301	245	299	212	296	179
	57	28.0	353	353	339	339	328	328	318	318	307	307	297	297	282	270	278	236
12000	75	29.2	372	284	369	235	367	200	363	166	358	128	---	---	---	---	---	---
	72	28.8	362	324	356	274	354	237	351	201	347	167	343	130	---	---	---	---
	67	28.4	361	361	347	347	335	302	330	263	327	228	325	192	321	159	316	120
	62	28.2	361	361	346	346	335	335	324	324	310	292	305	255	302	219	299	184
	57	28.1	361	361	346	346	335	335	324	324	314	314	303	303	287	282	283	247
13000	75	29.2	375	296	372	244	369	206	366	169	360	130	---	---	---	---	---	---
	72	28.9	365	339	358	285	356	246	354	207	350	171	345	133	---	---	---	---
	67	28.5	368	368	353	353	338	315	333	274	330	236	327	198	324	161	318	121
	62	28.3	368	368	353	353	341	341	330	330	314	305	309	267	305	226	302	188
	57	28.3	368	368	353	353	341	341	330	330	319	319	308	308	298	298	286	256

TABLE 27: COOLING PERFORMANCE - 25 TON STANDARD CAPACITY COIL (CONTINUED)

AIR ON EVAPORATOR COIL		105 °F AIR ON CONDENSER COIL																
		POWER INPUT KW	CAPACITY (MBH) AT ENTERING DRY BULB (F)															
			90		86		83		80		77		74		71		68	
CFM	WB°F	TOT	SEN	TOT	SEN	TOT	SEN	TOT	SEN	TOT	SEN	TOT	SEN	TOT	SEN	TOT	SEN	
6000	75	31.5	323	197	321	171	319	150	317	129	314	108	---	---	---	---	---	---
	72	31.2	309	217	308	192	307	173	305	152	302	131	300	110	---	---	---	---
	67	30.6	288	253	286	226	285	207	284	188	282	170	281	149	278	128	276	106
	62	30.2	281	281	268	261	266	242	263	222	262	203	261	183	260	164	258	144
	57	30.0	281	281	270	270	263	263	255	255	245	236	243	218	241	197	240	178
7000	75	31.7	332	212	330	182	328	160	325	135	322	111	---	---	---	---	---	---
	72	31.4	318	235	317	206	315	184	313	162	311	138	307	113	---	---	---	---
	67	30.8	299	276	294	245	294	223	293	201	291	180	289	157	286	133	283	108
	62	30.4	297	297	286	286	275	263	273	241	271	218	270	196	268	173	266	152
	57	30.2	297	297	286	286	277	277	269	269	261	261	252	235	249	212	248	190
8000	75	31.9	339	226	337	192	334	168	331	141	327	113	---	---	---	---	---	---
	72	31.6	325	253	323	219	322	194	320	169	317	144	313	116	---	---	---	---
	67	31.0	307	299	303	264	300	238	299	213	297	189	295	164	292	138	289	110
	62	30.6	311	311	298	298	289	289	281	258	277	232	276	208	274	183	272	158
	57	30.4	311	311	298	298	289	289	280	280	271	271	259	251	257	227	254	200
9000	75	32.0	344	239	342	202	340	175	336	147	332	116	---	---	---	---	---	---
	72	31.7	332	271	329	232	327	204	325	176	322	150	318	118	---	---	---	---
	67	31.2	323	323	310	283	307	255	305	223	302	197	300	170	297	143	293	111
	62	30.8	322	322	309	309	299	299	287	275	284	248	281	218	279	191	277	163
	57	30.7	322	322	309	309	299	299	290	290	281	281	272	272	262	240	259	211
10000	75	32.1	349	253	346	211	344	181	340	152	336	118	---	---	---	---	---	---
	72	31.8	338	287	333	244	331	213	329	183	326	154	321	120	---	---	---	---
	67	31.3	332	332	315	299	312	269	309	235	306	205	304	175	301	147	296	112
	62	31.0	332	332	319	319	308	308	298	298	289	261	285	229	283	197	280	168
	57	30.9	332	332	318	318	308	308	298	298	288	288	279	279	267	252	263	221
11000	75	32.2	352	266	350	221	347	187	343	156	339	121	---	---	---	---	---	---
	72	31.8	342	302	337	256	335	222	332	189	327	157	324	123	---	---	---	---
	67	31.4	341	341	321	316	316	282	312	246	310	214	307	181	304	150	298	113
	62	31.1	340	340	326	326	316	316	305	305	293	273	288	239	286	205	284	172
	57	31.0	340	340	326	326	316	316	305	305	295	295	285	285	271	264	266	230
12000	75	32.2	355	278	353	229	350	194	346	160	340	122	---	---	---	---	---	---
	72	31.9	346	317	340	267	337	231	335	195	330	161	327	125	---	---	---	---
	67	31.5	348	348	333	333	320	295	315	256	313	222	310	186	305	152	301	115
	62	31.3	348	348	333	333	322	322	312	312	297	288	293	251	289	212	286	177
	57	31.2	348	348	333	333	322	322	312	312	301	301	291	291	281	281	270	240
13000	75	32.2	361	294	355	238	353	200	349	163	343	125	---	---	---	---	---	---
	72	31.9	351	335	344	282	340	240	336	200	333	164	328	127	---	---	---	---
	67	31.6	354	354	339	339	324	311	320	269	315	229	312	191	307	154	303	116
	62	31.4	354	354	339	339	328	328	317	317	301	297	296	260	291	219	289	181
	57	31.3	354	354	339	339	328	328	317	317	307	307	296	296	286	286	273	249

TABLE 28: COOLING PERFORMANCE - 30 TON STANDARD CAPACITY COIL

AIR ON EVAPORATOR COIL		85 °F AIR ON CONDENSER COIL																
		POWER INPUT KW	CAPACITY (MBH) AT ENTERING DRY BULB (F)															
			90		86		83		80		77		74		71		68	
CFM	WB°F	TOT	SEN	TOT	SEN	TOT	SEN	TOT	SEN	TOT	SEN	TOT	SEN	TOT	SEN	TOT	SEN	
6000	75	31.0	388	222	387	195	386	174	384	154	382	133	---	---	---	---	---	---
	72	30.6	371	244	370	217	369	197	368	177	366	157	364	136	---	---	---	---
	67	30.0	342	280	341	254	341	234	340	214	339	194	338	174	337	153	335	133
	62	29.4	318	316	316	289	314	269	313	249	313	229	312	209	312	189	311	169
	57	28.9	318	318	306	306	298	298	290	283	289	263	287	243	287	223	286	203
7000	75	31.2	400	239	399	208	397	184	396	160	393	136	---	---	---	---	---	---
	72	30.9	382	265	382	234	381	210	379	187	378	163	375	139	---	---	---	---
	67	30.2	355	307	353	276	353	253	352	230	351	206	350	183	348	159	346	135
	62	29.7	339	339	329	318	327	294	325	271	324	248	324	224	323	201	322	177
	57	29.4	338	338	326	326	316	316	307	307	301	288	299	264	298	241	297	218
8000	75	31.4	409	256	408	220	406	193	404	166	401	138	---	---	---	---	---	---
	72	31.1	392	285	391	250	390	223	388	196	386	169	383	141	---	---	---	---
	67	30.4	366	334	362	298	362	271	361	245	360	218	358	191	356	164	354	136
	62	29.9	356	356	342	342	337	319	335	292	333	265	332	239	331	212	330	185
	57	29.7	355	355	342	342	332	332	322	322	312	312	308	285	306	258	305	232
9000	75	31.6	417	273	415	233	413	202	411	172	408	140	---	---	---	---	---	---
	72	31.2	399	306	398	266	397	236	395	205	393	175	390	143	---	---	---	---
	67	30.6	373	359	371	320	369	290	368	260	367	230	365	199	363	169	360	138
	62	30.1	370	370	356	356	345	341	343	312	340	283	339	253	338	223	337	193
	57	30.0	370	370	356	356	345	345	335	335	324	324	316	304	314	275	312	245
10000	75	31.7	422	290	421	245	419	211	416	177	413	143	---	---	---	---	---	---
	72	31.4	405	326	404	281	402	248	401	214	398	180	395	146	---	---	---	---
	67	30.7	382	380	378	339	375	308	374	275	372	241	371	207	368	173	365	139
	62	30.2	383	383	368	368	357	357	350	331	347	300	345	267	344	234	342	200
	57	30.2	382	382	367	367	357	357	346	346	335	335	323	321	320	290	318	258
11000	75	31.8	427	307	425	258	423	221	421	183	417	145	---	---	---	---	---	---
	72	31.5	411	346	408	297	407	260	405	223	403	186	399	148	---	---	---	---
	67	30.8	394	394	383	358	381	324	379	289	377	253	375	216	373	178	369	140
	62	30.3	394	394	378	378	367	367	355	348	352	315	350	280	348	244	347	207
	57	30.4	393	393	378	378	366	366	355	355	344	344	333	333	325	304	322	269
12000	75	31.9	431	322	429	270	427	230	425	189	420	147	---	---	---	---	---	---
	72	31.5	416	363	412	311	411	273	409	232	407	192	403	150	---	---	---	---
	67	30.9	404	404	388	377	385	339	383	302	381	263	379	223	376	183	372	141
	62	30.6	403	403	387	387	375	375	364	364	357	329	354	291	352	253	350	214
	57	30.6	403	403	387	387	375	375	363	363	352	352	340	340	330	317	326	280
13000	75	32.0	434	336	432	281	430	239	428	195	423	150	---	---	---	---	---	---
	72	31.6	420	378	416	324	414	283	412	241	410	197	406	153	---	---	---	---
	67	31.0	412	412	393	392	390	354	386	314	384	272	382	231	380	187	375	142
	62	30.7	411	411	395	395	383	383	371	371	361	342	357	302	356	261	353	220
	57	30.7	411	411	395	395	383	383	371	371	359	359	347	347	333	329	330	291
14000	75	32.1	437	350	435	291	433	246	431	200	426	152	---	---	---	---	---	---
	72	31.7	424	394	419	337	417	293	415	249	412	203	408	155	---	---	---	---
	67	31.1	419	419	403	403	393	368	390	326	387	281	385	237	382	192	378	143
	62	30.9	419	419	402	402	390	390	377	377	364	355	361	314	359	269	356	226
	57	30.9	418	418	402	402	389	389	377	377	365	365	353	353	341	341	333	300
15000	75	32.1	441	364	438	301	436	254	433	206	428	154	---	---	---	---	---	---
	72	31.7	427	411	422	350	420	302	418	256	415	209	410	157	---	---	---	---
	67	31.2	426	426	409	409	396	383	393	337	390	290	388	243	385	196	380	145
	62	31.0	425	425	408	408	396	396	383	383	368	366	364	324	361	277	359	231
	57	31.0	425	425	408	408	395	395	383	383	370	370	358	358	346	346	336	310

TABLE 28: COOLING PERFORMANCE - 30 TON STANDARD CAPACITY COIL ((CONTINUED))

AIR ON EVAPORATOR COIL		95°F AIR ON CONDENSER COIL																
		POWER INPUT kW	CAPACITY (MBH) AT ENTERING DRY BULB (F)															
			90		86		83		80		77		74		71		68	
CFM	WB°F	TOT	SEN	TOT	SEN	TOT	SEN	TOT	SEN	TOT	SEN	TOT	SEN	TOT	SEN	TOT	SEN	
6000	75	34.5	373	216	372	189	371	169	369	148	367	128	---	---	---	---	---	---
	72	34	356	238	355	211	354	191	353	171	352	151	350	130	---	---	---	---
	67	33.3	329	274	328	248	327	228	327	208	326	188	325	168	323	147	321	126
	62	32.7	308	308	303	283	302	263	301	243	300	223	300	203	299	183	298	163
	57	32.2	308	308	296	296	288	288	279	277	278	257	276	237	275	217	275	197
7000	75	34.7	384	233	383	202	381	178	379	154	377	130	---	---	---	---	---	---
	72	34.3	367	259	366	228	365	204	364	181	362	157	360	133	---	---	---	---
	67	33.6	341	301	339	270	338	247	338	223	337	200	335	176	333	153	331	128
	62	33	327	327	316	312	314	288	312	264	311	241	310	218	309	195	308	171
8000	57	32.6	327	327	314	314	305	305	296	296	288	282	287	258	285	235	285	211
	75	34.9	392	250	391	214	389	187	387	160	384	132	---	---	---	---	---	---
	72	34.5	376	279	375	244	373	217	372	190	370	163	367	135	---	---	---	---
	67	33.8	351	328	348	292	347	265	346	239	345	212	343	185	341	158	338	130
	62	33.2	344	344	330	330	322	312	321	286	319	259	318	232	317	206	316	179
9000	57	32.9	343	343	330	330	320	320	310	310	301	301	295	279	293	252	292	225
	75	35.1	399	267	397	227	396	196	393	166	390	135	---	---	---	---	---	---
	72	34.6	382	300	381	260	380	230	378	199	376	168	373	137	---	---	---	---
	67	34	359	352	356	314	353	283	352	254	351	223	349	193	347	162	344	131
	62	33.4	357	357	343	343	333	333	329	306	325	276	325	247	324	216	322	186
10000	57	33.2	357	357	343	343	333	333	322	322	312	312	302	297	300	269	298	238
	75	35.2	404	284	403	239	401	206	398	171	395	137	---	---	---	---	---	---
	72	34.8	389	320	387	276	385	242	383	208	381	174	378	140	---	---	---	---
	67	34.1	369	369	362	334	359	302	358	268	356	235	355	201	352	167	349	132
	62	33.5	369	369	355	355	344	344	334	325	332	293	330	260	329	227	327	193
11000	57	33.6	369	369	354	354	343	343	333	333	322	322	312	312	306	283	303	251
	75	35.3	408	301	407	252	405	215	402	177	398	139	---	---	---	---	---	---
	72	34.9	394	340	391	291	389	254	388	217	385	180	381	142	---	---	---	---
	67	34.2	380	380	367	352	365	318	362	283	361	246	359	209	356	172	352	134
	62	33.7	379	379	364	364	353	353	342	342	337	308	334	273	333	237	331	200
12000	57	33.8	379	379	364	364	353	353	342	342	331	331	319	319	311	296	308	262
	75	35.4	412	316	411	264	409	224	406	183	402	141	---	---	---	---	---	---
	72	35	399	356	394	305	393	267	391	226	389	186	385	144	---	---	---	---
	67	34.3	389	389	372	367	369	333	366	295	364	257	362	217	359	176	355	135
	62	34	388	388	373	373	361	361	350	350	342	321	338	284	337	246	334	207
13000	57	34	388	388	372	372	361	361	349	349	338	338	327	327	315	308	312	273
	75	35.5	415	330	414	275	412	233	409	189	404	144	---	---	---	---	---	---
	72	35	402	372	397	318	396	277	394	235	391	191	387	146	---	---	---	---
	67	34.4	397	397	381	381	373	347	369	306	367	266	365	225	362	181	358	136
	62	34.2	396	396	380	380	368	368	357	357	345	334	342	296	340	254	337	213
14000	57	34.2	396	396	380	380	368	368	356	356	344	344	333	333	322	322	315	283
	75	35.6	419	345	416	285	414	241	411	194	407	146	---	---	---	---	---	---
	72	35.1	406	389	401	332	399	287	397	243	394	197	390	149	---	---	---	---
	67	34.5	404	404	387	387	375	361	373	319	370	274	368	231	365	185	359	137
	62	34.3	403	403	387	387	375	375	363	363	349	345	345	306	342	262	340	218
15000	57	34.3	403	403	386	386	374	374	362	362	350	350	338	338	327	327	318	292
	75	35.6	422	357	419	295	417	248	413	200	409	148	---	---	---	---	---	---
	72	35.2	409	402	404	343	401	296	399	250	396	203	392	151	---	---	---	---
	67	34.6	410	410	393	393	379	372	375	330	373	284	370	237	367	190	362	138
	62	34.5	409	409	393	393	380	380	368	368	356	356	348	316	345	270	342	223
57	34.5	409	409	392	392	380	380	367	367	355	355	343	343	331	331	321	302	

TABLE 28: COOLING PERFORMANCE - 30 TON STANDARD CAPACITY COIL (CONTINUED)

AIR ON EVAPORATOR COIL		105 °F AIR ON CONDENSER COIL																
		POWER INPUT KW	CAPACITY (MBH) AT ENTERING DRY BULB (F)															
			90		86		83		80		77		74		71		68	
CFM	WB°F	TOT	SEN	TOT	SEN	TOT	SEN	TOT	SEN	TOT	SEN	TOT	SEN	TOT	SEN	TOT	SEN	
6000	75	38.5	357	210	356	183	355	163	353	142	351	122	---	---	---	---	---	---
	72	38	341	232	340	205	339	185	338	165	337	145	335	124	---	---	---	---
	67	37.2	315	268	314	241	313	222	313	202	312	182	311	161	309	141	307	120
	62	36.5	297	297	291	277	289	257	288	236	287	217	287	197	286	177	285	157
	57	36	297	297	286	286	277	277	269	269	266	251	264	231	263	211	263	191
7000	75	38.8	367	227	366	196	364	172	363	148	360	124	---	---	---	---	---	---
	72	38.2	351	253	350	222	349	198	348	175	346	151	344	127	---	---	---	---
	67	37.4	327	295	324	263	323	240	322	217	322	194	320	170	319	146	316	122
	62	36.8	316	316	303	303	300	282	298	258	297	235	296	212	295	188	294	165
	57	36.4	315	315	303	303	294	294	285	285	276	275	274	252	272	228	272	205
8000	75	39	374	244	373	208	372	181	370	154	367	126	---	---	---	---	---	---
	72	38.5	359	273	357	238	356	211	355	184	353	157	350	129	---	---	---	---
	67	37.7	335	321	333	286	331	259	330	232	329	205	328	178	326	151	323	123
	62	37	331	331	318	318	309	306	307	279	305	252	304	226	303	199	301	172
	57	36.9	330	330	317	317	308	308	298	298	289	289	282	272	280	245	279	218
9000	75	39.2	380	261	379	221	377	191	375	160	372	129	---	---	---	---	---	---
	72	38.7	365	293	364	254	362	223	361	193	359	162	356	131	---	---	---	---
	67	37.8	344	344	340	307	337	277	336	247	335	217	333	187	331	156	328	125
	62	37.2	343	343	330	330	320	320	314	299	311	270	310	240	308	210	307	179
	57	37.1	343	343	329	329	319	319	309	309	300	300	290	290	287	262	284	232
10000	75	39.3	385	278	384	233	382	200	380	166	376	131	---	---	---	---	---	---
	72	38.9	371	314	369	269	367	236	365	202	363	168	360	134	---	---	---	---
	67	37.9	356	356	345	326	343	295	341	262	340	228	338	195	336	161	332	126
	62	37.4	355	355	340	340	330	330	319	316	317	286	314	254	313	220	311	187
	57	37.3	354	354	340	340	329	329	319	319	309	309	299	299	292	276	289	244
11000	75	39.4	389	295	388	246	386	209	384	171	380	133	---	---	---	---	---	---
	72	39	376	333	373	285	371	248	369	211	367	174	363	136	---	---	---	---
	67	38.1	365	365	351	345	348	311	345	276	344	240	342	203	339	165	335	127
	62	37.7	365	365	349	349	339	339	328	328	321	300	318	265	317	230	315	194
	57	37.6	364	364	349	349	338	338	327	327	317	317	306	306	296	288	293	255
12000	75	39.5	393	309	391	257	389	218	387	177	383	136	---	---	---	---	---	---
	72	39.1	381	350	376	299	374	259	372	220	370	179	366	138	---	---	---	---
	67	38.2	373	373	358	358	352	326	348	287	347	249	345	211	342	170	338	128
	62	37.8	373	373	357	357	346	346	335	335	326	314	322	277	320	239	318	200
	57	37.8	373	373	357	357	346	346	334	334	323	323	312	312	302	302	297	265
13000	75	39.6	397	324	394	267	392	226	389	183	384	138	---	---	---	---	---	---
	72	39.2	383	366	379	311	377	269	375	227	373	185	369	140	---	---	---	---
	67	38.3	381	381	365	365	355	340	352	300	350	259	348	218	345	174	340	129
	62	38	380	380	365	365	353	353	341	341	329	326	326	288	323	247	321	206
	57	38	380	380	364	364	352	352	341	341	329	329	318	318	307	307	300	275
14000	75	39.7	400	338	397	279	394	233	392	188	386	140	---	---	---	---	---	---
	72	39.2	387	379	382	323	379	279	378	234	375	191	370	142	---	---	---	---
	67	38.4	387	387	371	371	359	351	355	312	352	268	350	224	347	179	342	130
	62	38.1	387	387	371	371	359	359	347	347	336	336	329	299	325	255	323	211
	57	38.1	386	386	370	370	358	358	346	346	335	335	323	323	312	312	303	284
15000	75	39.7	403	350	399	288	396	240	393	193	388	142	---	---	---	---	---	---
	72	39.3	394	394	385	335	382	288	380	241	377	195	372	145	---	---	---	---
	67	38.4	392	392	377	377	365	365	358	323	354	277	352	230	349	183	344	132
	62	38.3	392	392	376	376	364	364	352	352	340	340	331	309	327	262	325	216
	57	38.3	391	391	376	376	364	364	351	351	340	340	328	328	316	316	305	293

TABLE 28: COOLING PERFORMANCE - 30 TON STANDARD CAPACITY COIL (CONTINUED)

AIR ON EVAPORATOR COIL		115 °F AIR ON CONDENSER COIL																
		POWER INPUT KW	CAPACITY (MBH) AT ENTERING DRY BULB (F)															
			90		86		83		80		77		74		71		68	
CFM	WB°F	TOT	SEN	TOT	SEN	TOT	SEN	TOT	SEN	TOT	SEN	TOT	SEN	TOT	SEN	TOT	SEN	
6000	75	43	341	204	339	177	338	157	337	136	334	116	---	---	---	---	---	---
	72	42.5	325	226	324	199	323	179	322	159	321	138	319	118	---	---	---	---
	67	41.7	301	262	299	235	299	215	298	195	297	175	296	155	295	135	293	114
	62	40.7	286	286	277	270	276	250	274	230	274	210	273	190	272	170	271	150
	57	40.3	286	286	275	275	266	266	258	258	253	244	252	224	250	204	250	184
7000	75	43.3	350	221	348	190	347	166	345	142	343	118	---	---	---	---	---	---
	72	42.8	334	246	333	215	332	192	331	168	329	144	327	120	---	---	---	---
	67	41.8	312	289	309	257	308	234	307	211	306	187	305	164	303	140	301	115
	62	41	303	303	291	291	286	275	284	252	282	228	282	205	281	182	280	158
	57	40.8	303	303	291	291	282	282	273	273	265	265	261	245	259	221	258	198
8000	75	43.5	356	238	355	202	354	175	352	148	349	120	---	---	---	---	---	---
	72	42.8	341	267	340	231	339	205	338	178	336	150	333	123	---	---	---	---
	67	42	320	315	317	279	314	252	314	226	313	199	311	172	309	145	306	117
	62	41.3	318	318	305	305	296	296	292	273	290	246	289	219	287	192	286	165
	57	41.2	317	317	305	305	295	295	286	286	276	276	268	264	266	239	265	212
9000	75	43.7	362	255	360	215	359	185	357	154	353	123	---	---	---	---	---	---
	72	43	348	288	345	247	344	217	343	187	341	156	338	125	---	---	---	---
	67	42.2	330	330	323	300	321	271	319	240	318	210	316	180	314	149	311	118
	62	41.5	329	329	317	317	307	307	298	292	296	262	294	233	293	203	291	173
	57	41.6	329	329	316	316	306	306	296	296	287	287	277	277	272	254	270	225
10000	75	43.7	367	272	365	228	363	194	361	160	357	125	---	---	---	---	---	---
	72	43.2	353	308	350	263	349	230	347	196	345	162	341	127	---	---	---	---
	67	42.3	341	341	329	320	326	289	324	255	322	222	321	188	318	154	315	119
	62	41.9	340	340	326	326	316	316	306	306	301	277	298	245	297	213	295	180
	57	41.9	339	339	326	326	315	315	305	305	295	295	285	285	276	267	274	235
11000	75	43.8	370	289	368	240	367	203	364	165	360	127	---	---	---	---	---	---
	72	43.5	357	324	353	278	353	242	351	205	348	168	345	130	---	---	---	---
	67	42.5	349	349	335	335	331	304	327	269	326	233	324	196	321	159	317	120
	62	42.2	349	349	334	334	324	324	314	314	304	291	302	257	300	223	298	186
	57	42	348	348	334	334	323	313	313	303	303	292	292	282	282	278	278	247
12000	75	43.9	374	305	372	253	370	212	367	171	363	130	---	---	---	---	---	---
	72	43.6	362	342	357	292	355	252	354	214	351	173	347	132	---	---	---	---
	67	42.6	357	357	343	343	334	318	331	281	329	241	327	204	324	163	320	122
	62	42.2	357	357	342	342	331	331	320	320	309	304	305	268	303	231	301	191
	57	42.2	356	356	341	341	330	330	319	319	309	309	298	298	288	288	281	256
13000	75	44.2	378	318	374	263	372	220	369	177	365	132	---	---	---	---	---	---
	72	43.7	365	358	361	305	358	264	356	221	353	179	349	134	---	---	---	---
	67	42.9	364	364	349	349	338	332	334	291	331	250	330	210	326	168	321	122
	62	42.4	363	363	348	348	337	337	326	326	315	315	308	278	306	239	304	197
	57	42.4	363	363	348	348	336	336	325	325	314	314	304	304	293	293	284	267
14000	75	44.2	380	331	377	272	374	227	371	182	367	134	---	---	---	---	---	---
	72	43.8	371	371	364	317	360	274	358	228	355	184	351	136	---	---	---	---
	67	43	370	370	354	354	343	343	337	302	334	261	331	215	328	172	322	123
	62	42.6	369	369	354	354	342	342	331	331	320	320	311	288	308	247	306	203
	57	42.6	369	369	353	353	342	342	330	330	319	319	308	308	297	297	287	276
15000	75	44.3	383	344	379	282	376	233	373	187	368	137	---	---	---	---	---	---
	72	43.8	376	376	366	329	363	283	360	234	357	188	353	139	---	---	---	---
	67	43.1	375	375	359	359	348	348	339	313	335	268	333	221	330	176	324	124
	62	42.7	375	375	359	359	347	347	335	335	324	324	313	300	310	255	308	208
	57	42.7	374	374	359	359	347	347	335	335	323	323	312	312	301	301	289	283

TABLE 29: COOLING PERFORMANCE - 30 TON HIGH CAPACITY COIL

AIR ON EVAPORATOR COIL		85°F AIR ON CONDENSER COIL																
		POWER INPUT KW	CAPACITY (MBH) AT ENTERING DRY BULB (°F)															
			90		86		83		80		77		74		71		68	
CFM	WB°F	TOT	SEN	TOT	SEN	TOT	SEN	TOT	SEN	TOT	SEN	TOT	SEN	TOT	SEN	TOT	SEN	
6000	75	31.4	404	228	403	201	402	181	401	161	400	140	---	---	---	---	---	---
	72	31.0	385	250	385	224	384	204	383	184	382	163	381	143	---	---	---	---
	67	30.4	355	286	354	260	354	240	354	220	353	200	353	180	352	160	350	140
	62	29.8	328	321	327	295	326	275	325	255	325	235	325	216	324	196	324	176
	57	29.2	324	324	312	312	303	303	299	288	299	269	298	249	298	229	298	210
7000	75	31.7	417	245	416	214	415	190	413	167	411	143	---	---	---	---	---	---
	72	31.3	398	271	397	240	397	217	396	193	395	170	393	146	---	---	---	---
	67	30.6	369	313	367	282	367	259	367	236	366	213	365	189	364	166	362	142
	62	30.0	346	346	340	323	340	300	338	277	337	254	337	231	337	208	336	184
	57	29.5	346	346	333	333	323	323	314	314	311	293	311	271	310	247	309	224
8000	75	31.9	426	262	425	227	424	200	422	172	420	145	---	---	---	---	---	---
	72	31.5	408	291	407	256	406	229	405	203	404	175	402	148	---	---	---	---
	67	30.9	380	340	378	304	377	278	376	251	375	225	374	198	373	171	371	143
	62	30.3	364	364	351	351	349	325	348	299	347	272	347	246	346	219	345	192
	57	29.8	364	364	350	350	340	340	330	330	323	318	321	292	319	265	318	238
9000	75	32.1	434	279	433	239	431	209	429	178	427	147	---	---	---	---	---	---
	72	31.7	416	312	415	272	414	242	413	212	411	181	408	150	---	---	---	---
	67	31.0	389	367	387	327	385	296	384	266	383	236	382	206	380	176	377	145
	62	30.4	380	380	366	366	359	350	357	320	355	290	354	260	353	230	352	200
	57	30.1	380	380	365	365	354	354	344	344	333	333	328	312	327	282	326	252
10000	75	32.2	440	296	439	251	437	218	435	184	432	149	---	---	---	---	---	---
	72	31.8	423	332	421	288	420	254	418	221	416	187	413	152	---	---	---	---
	67	31.1	397	393	393	348	392	315	390	281	389	248	388	214	386	180	382	146
	62	30.6	394	394	378	378	367	367	363	341	362	307	360	274	359	240	358	207
	57	30.4	393	393	378	378	367	367	356	356	345	345	336	332	334	299	332	265
11000	75	32.3	445	313	444	264	442	227	440	189	436	151	---	---	---	---	---	---
	72	32.0	429	353	426	304	425	267	423	230	421	192	418	155	---	---	---	---
	67	31.2	406	406	399	370	397	333	395	296	394	259	392	222	390	185	386	147
	62	30.7	405	405	390	390	378	378	370	362	368	325	366	288	364	251	363	214
	57	30.6	405	405	389	389	377	377	366	366	354	354	343	343	339	315	337	278
12000	75	32.4	450	330	448	276	446	236	443	195	439	153	---	---	---	---	---	---
	72	32.0	434	373	431	319	429	279	427	239	425	198	421	157	---	---	---	---
	67	31.3	416	416	405	392	402	351	400	311	398	270	396	230	394	189	390	148
	62	30.9	416	416	399	399	387	387	376	376	372	342	370	302	368	261	366	221
	57	30.8	415	415	399	399	387	387	375	375	363	363	351	351	344	329	341	291
13000	75	32.5	454	347	451	289	449	245	447	200	442	156	---	---	---	---	---	---
	72	32.1	438	394	434	335	432	291	431	248	428	204	424	159	---	---	---	---
	67	31.4	425	425	411	409	406	369	404	326	401	282	400	238	397	194	393	149
	62	31.0	425	425	408	408	396	396	383	383	377	357	374	315	372	272	370	228
	57	31.0	424	424	408	408	395	395	383	383	371	371	358	358	349	343	345	304
14000	75	32.5	458	364	454	301	452	254	451	206	445	158	---	---	---	---	---	---
	72	32.2	442	413	438	351	435	304	433	257	431	209	426	161	---	---	---	---
	67	31.5	433	433	416	416	410	386	407	340	404	293	403	246	399	198	395	150
	62	31.2	433	433	416	416	403	403	390	390	381	372	378	329	375	282	373	235
	57	31.2	432	432	415	415	402	402	390	390	377	377	365	365	353	353	349	315
15000	75	32.6	461	381	457	313	455	263	453	212	446	160	---	---	---	---	---	---
	72	32.3	446	430	441	367	438	316	436	266	433	215	428	163	---	---	---	---
	67	31.6	441	441	423	423	414	400	410	354	407	304	405	254	402	203	393	150
	62	31.3	440	440	422	422	409	409	397	397	385	385	381	340	377	292	375	241
	57	31.3	440	440	422	422	409	409	396	396	383	383	371	371	358	358	351	326

TABLE 29: COOLING PERFORMANCE - 30 TON HIGH CAPACITY COIL (CONTINUED)

AIR ON EVAPORATOR COIL		95°F AIR ON CONDENSER COIL																
		POWER INPUT KW	CAPACITY (MBH) AT ENTERING DRY BULB (°F)															
			90		86		83		80		77		74		71		68	
CFM	WB°F	TOT	SEN	TOT	SEN	TOT	SEN	TOT	SEN	TOT	SEN	TOT	SEN	TOT	SEN	TOT	SEN	
6000	75	34.9	388	221	387	195	386	175	385	154	383	134	---	---	---	---	---	
	72	34.5	369	244	369	217	369	197	368	177	367	157	365	136	---	---	---	
	67	33.8	341	280	340	253	340	233	340	214	339	194	338	174	338	154	336	133
	62	33	313	313	314	288	313	268	312	248	312	229	312	209	311	189	310	169
	57	32.4	313	313	302	302	293	293	288	282	287	262	286	243	286	223	285	203
7000	75	35.2	399	239	398	208	397	184	396	160	394	136	---	---	---	---	---	
	72	34.8	381	264	381	234	380	210	379	187	378	163	376	139	---	---	---	
	67	34.1	354	307	352	276	351	252	351	229	351	206	350	183	348	159	347	135
	62	33.4	334	334	326	317	325	294	324	270	323	247	323	224	322	201	321	178
	57	32.8	334	334	321	321	312	312	303	303	299	287	298	264	297	241	296	218
8000	75	35.4	408	256	407	220	406	193	404	166	402	138	---	---	---	---	---	
	72	35	390	285	390	250	389	223	388	196	386	169	384	141	---	---	---	
	67	34.3	363	333	362	298	360	271	360	245	359	218	358	191	357	164	354	137
	62	33.6	352	352	338	338	335	319	334	292	332	265	332	239	331	212	330	185
	57	33.1	351	351	338	338	328	328	318	318	308	308	307	285	306	258	305	231
9000	75	35.5	415	273	414	233	413	202	411	172	408	141	---	---	---	---	---	
	72	35.2	399	306	397	265	396	235	395	205	393	175	390	144	---	---	---	
	67	34.5	373	360	370	320	368	290	367	260	366	230	365	199	363	169	360	138
	62	33.8	367	367	352	352	341	341	341	313	340	283	338	253	338	223	336	193
	57	33.5	366	366	352	352	341	341	331	331	320	320	315	305	313	275	311	245
10000	75	35.7	421	290	420	245	418	211	416	177	412	143	---	---	---	---	---	
	72	35.3	405	326	402	281	401	248	400	214	398	180	395	146	---	---	---	
	67	34.6	379	379	376	341	374	308	372	274	372	241	370	207	368	173	365	139
	62	34	379	379	365	365	354	354	348	334	346	300	344	267	343	233	342	200
	57	33.8	379	379	364	364	353	353	342	342	331	331	321	321	319	291	317	258
11000	75	35.8	426	307	424	258	422	220	420	183	416	145	---	---	---	---	---	
	72	35.5	411	347	407	297	406	260	404	223	402	186	399	148	---	---	---	
	67	34.7	391	391	382	363	380	326	378	289	376	252	375	215	372	178	368	140
	62	34.1	391	391	375	375	364	364	355	353	351	318	349	281	347	244	346	207
	57	34.1	390	390	375	375	363	363	352	352	341	341	329	329	324	307	322	271
12000	75	36	431	324	428	270	426	229	423	189	419	147	---	---	---	---	---	
	72	35.5	414	367	412	313	410	273	408	232	406	191	402	150	---	---	---	
	67	34.8	401	401	388	384	384	344	382	304	380	264	378	223	376	183	371	141
	62	34.3	400	400	384	384	372	372	361	361	356	334	353	294	351	254	350	214
	57	34.3	400	400	384	384	372	372	360	360	349	349	337	337	329	322	326	284
13000	75	36	434	341	431	282	429	238	426	194	422	149	---	---	---	---	---	
	72	35.6	419	387	415	329	413	285	411	241	409	197	404	152	---	---	---	
	67	34.9	409	409	393	393	388	363	386	319	383	275	381	231	378	187	372	141
	62	34.5	409	409	392	392	380	380	368	368	360	348	357	308	354	264	353	221
	57	34.5	408	408	392	392	380	380	368	368	356	356	344	344	332	332	329	295
14000	75	36.1	438	358	434	295	432	248	429	200	424	151	---	---	---	---	---	
	72	35.7	423	406	418	345	416	297	414	250	411	203	406	154	---	---	---	
	67	34.9	417	417	400	400	392	378	389	333	386	286	384	239	380	191	374	142
	62	34.7	416	416	400	400	387	387	375	375	364	362	360	320	357	274	355	227
	57	34.6	416	416	399	399	387	387	374	374	362	362	350	350	338	338	332	306
15000	75	36.2	440	375	436	307	434	257	431	206	426	154	---	---	---	---	---	
	72	35.8	427	422	421	361	418	310	416	259	413	208	407	156	---	---	---	
	67	35	424	424	406	406	396	391	392	347	388	297	386	247	383	196	377	144
	62	34.8	423	423	406	406	393	393	380	380	368	368	363	332	360	284	357	234
	57	34.8	423	423	405	405	393	393	380	380	368	368	355	355	343	343	335	316

TABLE 29: COOLING PERFORMANCE - 30 TON HIGH CAPACITY COIL (CONTINUED)

AIR ON EVAPORATOR COIL		105°F AIR ON CONDENSER COIL																	
		POWER INPUT kW	CAPACITY (MBH) AT ENTERING DRY BULB (°F)																
			90		86		83		80		77		74		71		68		
CFM	WB°F	TOT	SEN	TOT	SEN	TOT	SEN	TOT	SEN	TOT	SEN	TOT	SEN	TOT	SEN	TOT	SEN		
6000	75	38.9	371	215	370	188	369	168	368	148	366	127	---	---	---	---	---	---	
	72	38.4	353	237	353	211	353	191	352	171	351	150	349	130	---	---	---	---	
	67	37.5	326	273	325	247	325	227	325	207	324	187	324	167	323	147	321	126	
	62	36.7	302	302	299	281	299	262	299	242	298	222	298	202	297	182	297	162	162
	57	36.1	302	302	291	291	282	282	274	274	274	256	274	236	273	216	273	216	196
7000	75	39.2	381	232	381	201	380	178	378	154	376	130	---	---	---	---	---	---	
	72	38.7	364	258	364	227	363	204	362	180	361	156	359	132	---	---	---	---	
	67	37.9	338	300	337	269	336	246	335	223	335	199	334	176	332	152	330	128	
	62	37.1	322	322	310	309	310	286	310	264	309	240	308	217	308	194	307	171	171
	57	36.7	322	322	309	309	300	300	291	291	286	280	284	257	283	234	283	211	211
8000	75	39.5	390	249	389	214	387	187	386	160	383	132	---	---	---	---	---	---	
	72	39	373	279	372	243	371	216	370	189	368	162	366	135	---	---	---	---	
	67	38.2	347	327	346	291	344	264	343	238	343	211	342	184	340	157	337	129	
	62	37.3	338	338	325	325	320	312	319	285	317	258	316	232	315	205	314	178	178
	57	37.1	338	338	325	325	315	315	306	306	296	296	292	277	291	251	290	224	224
9000	75	39.6	396	267	395	226	393	196	391	165	388	134	---	---	---	---	---	---	
	72	39.2	380	299	378	259	377	229	376	199	374	168	371	137	---	---	---	---	
	67	38.2	353	352	353	313	351	283	350	253	349	223	348	192	346	162	342	131	
	62	37.5	352	352	338	338	328	328	325	306	324	276	322	246	322	216	320	185	185
	57	37.3	352	352	338	338	328	328	317	317	308	308	300	298	298	268	296	237	237
10000	75	39.8	401	283	400	239	398	205	396	171	393	136	---	---	---	---	---	---	
	72	39.3	386	320	383	275	382	241	381	208	379	174	375	139	---	---	---	---	
	67	38.5	365	365	359	335	357	301	355	267	354	234	352	200	350	166	347	132	
	62	37.9	365	365	350	350	339	339	332	327	329	293	328	260	327	226	325	193	
	57	37.6	364	364	349	349	339	339	328	328	317	317	317	307	307	303	284	302	251
11000	75	39.9	406	301	404	251	402	214	400	177	396	138	---	---	---	---	---	---	
	72	39.4	391	340	388	291	386	254	385	217	383	179	377	141	---	---	---	---	
	67	38.7	376	376	365	357	362	319	360	282	358	245	356	208	354	171	347	132	
	62	37.9	375	375	360	360	348	348	337	337	334	310	332	274	331	237	329	200	
	57	37.9	375	375	360	360	348	348	337	337	326	326	315	315	308	299	306	264	
12000	75	40	411	318	408	264	405	223	403	182	398	141	---	---	---	---	---	---	
	72	39.5	395	360	392	307	390	266	388	226	386	185	382	143	---	---	---	---	
	67	38.8	385	385	369	369	366	337	364	297	361	257	360	216	357	175	352	134	
	62	38.2	384	384	369	369	357	357	346	346	339	326	336	287	334	247	332	206	
	57	38.1	384	384	368	368	356	356	345	345	333	333	322	322	311	311	310	276	
13000	75	40.3	414	335	411	276	408	232	405	188	401	143	---	---	---	---	---	---	
	72	39.9	400	381	396	322	393	278	391	235	388	190	384	145	---	---	---	---	
	67	38.9	393	393	377	377	370	354	367	312	364	268	363	224	359	180	353	134	
	62	38.4	392	392	376	376	364	364	352	352	343	341	340	301	337	257	335	213	
	57	38.4	392	392	376	376	364	364	352	352	340	340	328	328	317	317	313	287	
14000	75	39.9	417	352	413	289	411	241	406	193	402	145	---	---	---	---	---	---	
	72	40	404	398	399	338	396	291	393	244	390	196	385	147	---	---	---	---	
	67	39	400	400	383	383	374	369	370	326	367	279	364	232	361	184	355	135	
	62	38.6	399	399	383	383	371	371	359	359	347	347	342	313	339	267	337	220	
	57	38.6	399	399	382	382	370	370	358	358	346	346	334	334	322	322	316	299	
15000	75	40.2	419	369	415	301	413	250	410	199	402	147	---	---	---	---	---	---	
	72	40.1	407	407	401	354	398	303	395	252	393	202	388	150	---	---	---	---	
	67	39.1	406	406	389	389	377	377	373	339	370	291	366	239	362	188	358	137	
	62	38.8	406	406	389	389	376	376	364	364	352	352	345	324	342	278	339	227	
	57	38.8	405	405	388	388	376	376	364	364	351	351	339	339	327	327	319	309	

TABLE 29: COOLING PERFORMANCE - 30 TON HIGH CAPACITY COIL (CONTINUED)

AIR ON EVAPORATOR COIL		115°F AIR ON CONDENSER COIL																
		POWER INPUT KW	CAPACITY (MBH) AT ENTERING DRY BULB (°F)															
			90		86		83		80		77		74		71		68	
CFM	WB°F	TOT	SEN	TOT	SEN	TOT	SEN	TOT	SEN	TOT	SEN	TOT	SEN	TOT	SEN	TOT	SEN	
6000	75	43.5	353	209	353	182	352	162	350	141	348	121	---	---	---	---	---	---
	72	42.9	337	231	336	204	336	184	335	164	334	144	332	123	---	---	---	---
	67	41.9	311	266	310	240	310	220	309	200	309	180	308	160	307	140	305	119
	62	41.2	291	291	286	274	285	255	284	235	284	215	284	195	283	175	282	155
	57	40.3	291	291	280	280	271	271	263	263	261	248	260	229	260	209	259	189
7000	75	43.8	363	226	362	195	361	171	360	147	357	123	---	---	---	---	---	---
	72	43.3	347	251	346	220	345	197	344	173	343	150	341	126	---	---	---	---
	67	42.4	321	293	321	262	319	239	319	216	318	192	317	169	316	145	314	121
	62	41.5	309	309	297	297	295	280	294	257	293	233	293	210	292	187	291	163
	57	41	309	309	297	297	288	288	279	279	270	270	270	250	269	227	268	203
8000	75	44	370	243	370	207	368	180	366	153	363	125	---	---	---	---	---	---
	72	43.5	355	272	354	236	353	210	352	183	350	155	347	128	---	---	---	---
	67	42.6	331	320	329	284	327	258	326	231	325	204	324	177	323	150	320	122
	62	41.8	325	325	312	312	303	302	277	301	251	300	224	299	198	298	171	171
	57	41.4	325	325	312	312	302	302	293	293	283	283	278	270	277	244	275	217
9000	75	44.1	377	260	375	220	374	189	371	159	368	128	---	---	---	---	---	---
	72	43.7	361	293	359	252	359	222	357	192	355	161	352	130	---	---	---	---
	67	42.8	338	338	335	306	334	276	332	246	331	216	330	185	328	155	324	123
	62	42	338	338	324	324	314	314	309	299	308	269	306	238	305	268	304	178
	57	41.8	337	337	324	324	314	314	304	304	294	294	284	284	282	260	281	230
10000	75	44.4	381	277	380	232	378	199	376	164	372	130	---	---	---	---	---	---
	72	43.9	367	313	364	268	363	235	362	201	359	167	356	132	---	---	---	---
	67	43	350	350	341	328	339	294	337	260	336	227	334	193	332	159	326	124
	62	42.4	349	349	335	335	324	324	314	314	312	286	311	252	309	219	308	185
	57	42.2	349	349	334	334	324	324	314	314	303	303	293	293	288	277	286	243
11000	75	44.5	386	294	383	245	382	208	379	170	374	132	---	---	---	---	---	---
	72	44	371	333	369	284	367	247	365	210	363	172	359	134	---	---	---	---
	67	43.1	359	359	345	345	343	312	341	275	339	238	338	201	335	164	330	125
	62	42.5	359	359	344	344	333	333	322	322	317	303	315	266	313	229	311	192
	57	42.3	358	358	344	344	333	333	322	322	311	311	301	301	293	291	290	256
12000	75	44.6	389	311	386	257	385	217	382	176	376	134	---	---	---	---	---	---
	72	44.1	376	354	372	300	370	259	368	219	366	178	360	136	---	---	---	---
	67	43.3	368	368	353	353	347	331	345	290	342	250	341	209	338	168	332	126
	62	42.5	367	367	352	352	341	341	329	329	322	318	319	280	316	239	314	199
	57	42.5	367	367	352	352	340	340	329	329	318	318	307	307	296	296	293	267
13000	75	44.5	393	328	389	270	387	226	384	181	380	136	---	---	---	---	---	---
	72	44.2	380	374	375	316	373	272	371	228	368	184	363	139	---	---	---	---
	67	43.4	375	375	360	360	352	347	348	305	345	261	343	217	340	173	336	128
	62	42.8	375	375	359	359	347	347	336	336	325	325	321	293	319	250	317	206
	57	42.7	374	374	359	359	347	347	335	335	324	324	313	313	302	302	296	280
14000	75	44.8	395	345	392	282	389	235	386	187	381	139	---	---	---	---	---	---
	72	44.3	383	383	378	332	375	284	373	237	370	189	366	141	---	---	---	---
	67	43.5	382	382	366	366	354	354	351	319	348	272	345	225	342	177	314	120
	62	43.1	382	382	366	366	354	354	342	342	330	330	324	305	321	260	319	213
	57	43.1	381	381	365	365	353	353	341	341	330	330	318	318	307	307	299	290
15000	75	45.1	398	362	394	295	390	244	387	193	390	143	---	---	---	---	---	---
	72	44.3	388	388	381	347	378	297	375	246	372	195	355	139	---	---	---	---
	67	43.4	388	388	371	371	359	359	354	332	350	283	347	233	344	182	333	128
	62	43.3	387	387	371	371	359	359	347	347	335	335	327	315	324	270	320	219
	57	43.3	387	387	371	371	358	358	346	346	334	334	323	323	311	311	302	298

TABLE 30: COOLING PERFORMANCE - 40 TON STANDARD CAPACITY COIL

AIR ON EVAPORATOR COIL		85 °F AIR ON CONDENSER COIL																
		POWER INPUT KW	CAPACITY (MBH) AT ENTERING DRY BULB (F)															
			90		86		83		80		77		74		71		68	
CFM	WB°F	TOT	SEN	TOT	SEN	TOT	SEN	TOT	SEN	TOT	SEN	TOT	SEN	TOT	SEN	TOT	SEN	
6000	75	31.4	404	228	403	201	402	181	401	161	400	140	---	---	---	---	---	---
	72	31.0	385	250	385	224	384	204	383	184	382	163	381	143	---	---	---	---
	67	30.4	355	286	354	260	354	240	354	220	353	200	353	180	352	160	350	140
	62	29.8	328	321	327	295	326	275	325	255	325	235	325	216	324	196	324	176
	57	29.2	324	324	312	312	303	303	299	288	299	269	298	249	298	229	298	210
7000	75	31.7	417	245	416	214	415	190	413	167	411	143	---	---	---	---	---	---
	72	31.3	398	271	397	240	397	217	396	193	395	170	393	146	---	---	---	---
	67	30.6	369	313	367	282	367	259	367	236	366	213	365	189	364	166	362	142
	62	30.0	346	346	340	323	340	300	338	277	337	254	337	231	337	208	336	184
	57	29.5	346	346	333	333	323	323	314	314	311	293	311	271	310	247	309	224
8000	75	31.9	426	262	425	227	424	200	422	172	420	145	---	---	---	---	---	---
	72	31.5	408	291	407	256	406	229	405	203	404	175	402	148	---	---	---	---
	67	30.9	380	340	378	304	377	278	376	251	375	225	374	198	373	171	371	143
	62	30.3	364	364	351	351	349	325	348	299	347	272	347	246	346	219	345	192
	57	29.8	364	364	350	350	340	340	330	330	323	318	321	292	319	265	318	238
9000	75	32.1	434	279	433	239	431	209	429	178	427	147	---	---	---	---	---	---
	72	31.7	416	312	415	272	414	242	413	212	411	181	408	150	---	---	---	---
	67	31.0	389	367	387	327	385	296	384	266	383	236	382	206	380	176	377	145
	62	30.4	380	380	366	366	359	350	357	320	355	290	354	260	353	230	352	200
	57	30.1	380	380	365	365	354	354	344	344	333	333	328	312	327	282	326	252
10000	75	32.2	440	296	439	251	437	218	435	184	432	149	---	---	---	---	---	---
	72	31.8	423	332	421	288	420	254	418	221	416	187	413	152	---	---	---	---
	67	31.1	397	393	393	348	392	315	390	281	389	248	388	214	386	180	382	146
	62	30.6	394	394	378	378	367	367	363	341	362	307	360	274	359	240	358	207
	57	30.4	393	393	378	378	367	367	356	356	345	345	336	332	334	299	332	265
11000	75	32.3	445	313	444	264	442	227	440	189	436	151	---	---	---	---	---	---
	72	32.0	429	353	426	304	425	267	423	230	421	192	418	155	---	---	---	---
	67	31.2	406	406	399	370	397	333	395	296	394	259	392	222	390	185	386	147
	62	30.7	405	405	390	390	378	378	370	362	368	325	366	288	364	251	363	214
	57	30.6	405	405	389	389	377	377	366	366	354	354	343	343	339	315	337	278
12000	75	32.4	450	330	448	276	446	236	443	195	439	153	---	---	---	---	---	---
	72	32.0	434	373	431	319	429	279	427	239	425	198	421	157	---	---	---	---
	67	31.3	416	416	405	392	402	351	400	311	398	270	396	230	394	189	390	148
	62	30.9	416	416	399	399	387	387	376	376	372	342	370	302	368	261	366	221
	57	30.8	415	415	399	399	387	387	375	375	363	363	351	351	344	329	341	291
13000	75	32.5	454	347	451	289	449	245	447	200	442	156	---	---	---	---	---	---
	72	32.1	438	394	434	335	432	291	431	248	428	204	424	159	---	---	---	---
	67	31.4	425	425	411	409	406	369	404	326	401	282	400	238	397	194	393	149
	62	31.0	425	425	408	408	396	396	383	383	377	357	374	315	372	272	370	228
	57	31.0	424	424	408	408	395	395	383	383	371	371	358	358	349	343	345	304
14000	75	32.5	458	364	454	301	452	254	451	206	445	158	---	---	---	---	---	---
	72	32.2	442	413	438	351	435	304	433	257	431	209	426	161	---	---	---	---
	67	31.5	433	433	416	416	410	386	407	340	404	293	403	246	399	198	395	150
	62	31.2	433	433	416	416	403	403	390	390	381	372	378	329	375	282	373	235
	57	31.2	432	432	415	415	402	402	390	390	377	377	365	365	353	353	349	315
15000	75	32.6	461	381	457	313	455	263	453	212	446	160	---	---	---	---	---	---
	72	32.3	446	430	441	367	438	316	436	266	433	215	428	163	---	---	---	---
	67	31.6	441	441	423	423	414	400	410	354	407	304	405	254	402	203	393	150
	62	31.3	440	440	422	422	409	409	397	397	385	385	381	340	377	292	375	241
	57	31.3	440	440	422	422	409	409	396	396	383	383	371	371	358	358	351	326

TABLE 30: COOLING PERFORMANCE - 40 TON STANDARD CAPACITY COIL (CONTINUED)

AIR ON EVAPORATOR COIL		95 °F AIR ON CONDENSER COIL																
		POWER INPUT KW	CAPACITY (MBH) AT ENTERING DRY BULB (F)															
			90		86		83		80		77		74		71		68	
CFM	WB°F	TOT	SEN	TOT	SEN	TOT	SEN	TOT	SEN	TOT	SEN	TOT	SEN	TOT	SEN	TOT	SEN	
8000	75	48.8	513	294	511	258	510	231	509	204	506	176	---	---	---	---	---	---
	72	48.1	489	323	488	288	487	261	486	234	485	207	483	180	---	---	---	---
	67	47.1	451	371	450	336	450	310	449	283	448	257	447	230	446	203	444	175
	62	46	418	418	416	383	414	356	414	330	413	304	412	277	412	251	411	224
	57	45.2	418	418	402	402	391	391	381	375	381	349	379	322	378	296	378	269
9000	75	49.1	524	311	523	271	522	240	520	210	517	179	---	---	---	---	---	---
	72	48.5	501	344	500	304	499	274	498	244	496	213	493	183	---	---	---	---
	67	47.5	464	398	463	358	461	329	461	299	460	269	459	239	457	208	455	177
	62	46.3	439	439	428	411	427	382	425	352	425	322	424	292	423	262	422	232
	57	45.7	438	438	422	422	410	410	398	398	391	372	391	343	389	313	389	284
10000	75	49.3	534	328	533	283	531	250	529	216	526	181	---	---	---	---	---	---
	72	48.7	511	364	510	320	509	287	507	253	505	219	502	185	---	---	---	---
	67	47.7	475	425	473	381	472	347	470	314	469	281	468	247	466	213	463	179
	62	46.6	457	457	439	439	437	407	436	373	434	340	433	307	432	274	430	240
	57	46.2	456	456	438	438	426	426	413	413	402	397	400	364	399	331	398	298
11000	75	49.5	542	345	540	296	539	259	536	221	533	183	---	---	---	---	---	---
	72	48.9	519	385	518	336	516	299	515	262	513	225	509	187	---	---	---	---
	67	47.7	483	451	482	403	480	366	479	329	477	293	475	256	473	218	470	181
	62	46.8	472	472	454	454	446	431	444	394	442	358	441	321	440	284	438	248
	57	46.4	472	472	454	454	440	440	427	427	414	414	407	383	407	348	405	311
12000	75	49.6	549	362	547	308	545	268	543	227	539	186	---	---	---	---	---	---
	72	49.1	526	405	524	352	523	312	521	272	519	231	515	190	---	---	---	---
	67	47.9	492	476	489	425	487	384	485	344	484	304	482	264	479	223	476	182
	62	47	487	487	468	468	454	451	452	415	449	375	448	335	446	295	444	255
	57	46.7	486	486	467	467	453	453	439	439	425	425	415	403	414	365	412	324
13000	75	49.7	555	379	553	321	551	277	548	233	544	188	---	---	---	---	---	---
	72	49.3	532	426	530	368	529	325	527	281	524	237	520	192	---	---	---	---
	67	48.1	500	498	496	446	493	403	491	359	489	316	487	272	485	228	481	183
	62	47.2	499	499	480	480	465	465	457	434	455	393	453	349	452	306	450	262
	57	47.1	499	499	479	479	465	465	451	451	436	436	422	418	419	381	417	338
14000	75	49.9	560	396	558	333	555	286	552	238	548	190	---	---	---	---	---	---
	72	49.4	538	446	535	384	534	337	531	290	529	242	524	194	---	---	---	---
	67	48.2	511	511	500	463	499	421	496	374	494	327	492	280	489	232	484	184
	62	47.5	510	510	490	490	476	476	463	449	461	409	458	363	457	316	454	269
	57	47.4	510	510	490	490	475	475	460	460	445	445	431	431	425	395	422	350
15000	75	50	564	413	562	346	559	295	556	244	552	192	---	---	---	---	---	---
	72	49.5	543	465	539	400	538	349	536	299	533	248	528	196	---	---	---	---
	67	48.3	521	521	506	481	503	437	500	389	499	338	496	288	493	237	488	185
	62	47.7	521	521	500	500	485	485	469	465	466	423	462	376	461	327	458	276
	57	47.6	520	520	499	499	484	484	469	469	454	454	439	439	429	407	426	362
16000	75	50.1	568	430	566	358	563	304	560	250	555	195	---	---	---	---	---	---
	72	49.6	547	482	543	415	542	362	539	308	536	254	532	199	---	---	---	---
	67	48.4	530	530	511	499	508	452	504	402	502	350	500	296	497	242	491	186
	62	47.9	530	530	509	509	493	493	478	478	469	435	467	388	464	337	462	283
	57	47.9	529	529	508	508	493	493	477	477	462	462	447	447	433	420	430	372
17000	75	50.2	572	445	569	371	566	313	563	255	558	197	---	---	---	---	---	---
	72	49.7	551	499	547	429	545	374	542	317	539	259	535	201	---	---	---	---
	67	48.5	539	539	517	517	511	467	508	415	506	360	503	304	499	246	492	187
	62	48.1	538	538	517	517	501	501	485	485	473	448	470	399	468	345	465	290
	57	48.1	537	537	516	516	500	500	484	484	469	469	453	453	437	431	434	383
18000	75	50.4	575	458	572	382	569	322	566	261	560	199	---	---	---	---	---	---
	72	49.8	555	515	550	440	548	385	545	326	542	265	537	203	---	---	---	---
	67	48.7	546	546	525	525	514	479	511	426	509	369	506	310	502	251	496	188
	62	48.3	546	546	524	524	508	508	492	492	477	461	474	410	471	353	468	297
	57	48.2	545	545	523	523	507	507	491	491	475	475	459	459	444	444	437	393
19000	75	50.5	578	472	575	392	572	331	568	267	562	201	---	---	---	---	---	---
	72	49.9	559	529	554	455	551	395	548	333	544	270	539	205	---	---	---	---
	67	48.8	553	553	531	531	518	494	514	437	511	379	509	318	505	255	498	189
	62	48.4	553	553	531	531	514	514	498	498	481	474	477	421	473	362	470	302
	57	48.4	552	552	530	530	513	513	497	497	481	481	465	465	449	449	440	403
20000	75	50.5	581	485	577	402	574	337	570	273	564	204	---	---	---	---	---	---
	72	49.9	563	546	556	466	553	404	550	340	547	276	541	207	---	---	---	---
	67	48.8	560	560	537	537	522	507	517	449	514	387	511	322	507	260	501	191
	62	48.6	559	559	537	537	520	520	503	503	487	487	479	431	476	370	473	307
	57	48.6	559	559	536	536	519	519	503	503	486	486	470	470	454	454	442	411

TABLE 30: COOLING PERFORMANCE - 40 TON STANDARD CAPACITY COIL (CONTINUED)

AIR ON EVAPORATOR COIL		105 °F AIR ON CONDENSER COIL																
		POWER INPUT KW	CAPACITY (MBH) AT ENTERING DRY BULB (F)															
			90		86		83		80		77		74		71		68	
CFM	WB°F	TOT	SEN	TOT	SEN	TOT	SEN	TOT	SEN	TOT	SEN	TOT	SEN	TOT	SEN	TOT	SEN	
8000	75	54.3	491	285	489	250	488	223	487	196	484	168	---	---	---	---	---	---
	72	53.7	468	315	467	279	466	253	465	226	464	199	461	171	---	---	---	---
	67	52.4	433	363	431	328	431	301	430	275	429	248	428	221	426	194	424	167
	62	51.3	403	403	397	373	397	348	396	321	395	295	395	268	394	242	393	215
	57	50.4	403	403	388	388	377	377	365	365	364	340	363	313	362	287	361	260
9000	75	54.7	502	303	500	262	499	232	497	202	494	171	---	---	---	---	---	---
	72	54	480	336	478	296	477	266	476	235	474	205	471	174	---	---	---	---
	67	52.7	444	390	442	350	442	320	441	290	440	260	438	230	437	199	434	168
	62	51.6	423	423	409	403	409	373	407	343	406	313	405	283	404	253	403	223
	57	50.9	423	423	407	407	395	395	382	382	374	364	373	334	372	304	371	275
10000	75	55	510	320	509	275	507	241	505	207	502	173	---	---	---	---	---	---
	72	54.3	488	356	487	312	486	278	484	245	482	211	479	176	---	---	---	---
	67	53	454	416	452	372	450	339	449	305	448	272	447	238	445	204	442	170
	62	51.9	440	440	423	423	417	397	416	364	414	331	413	298	412	264	411	231
	57	51.5	439	439	423	423	410	410	398	398	385	385	382	355	381	322	379	288
11000	75	55.2	518	337	516	288	514	251	512	213	508	175	---	---	---	---	---	---
	72	54.5	495	376	494	328	493	291	491	254	489	217	486	179	---	---	---	---
	67	53.2	463	443	460	394	458	357	457	320	455	284	454	247	451	209	448	171
	62	52.1	454	454	437	437	426	422	424	385	422	349	421	312	419	275	418	238
	57	51.9	454	454	436	436	424	424	411	411	398	398	389	375	388	339	386	302
12000	75	55.4	524	354	522	300	520	260	517	219	513	177	---	---	---	---	---	---
	72	54.7	502	397	500	344	499	303	497	263	495	222	491	181	---	---	---	---
	67	53.6	471	467	466	416	465	375	462	335	461	295	460	255	457	214	453	173
	62	52.4	468	468	449	449	436	436	430	405	429	366	427	326	425	286	423	246
	57	52.1	467	467	449	449	435	435	422	422	409	409	396	393	394	355	392	315
13000	75	55.5	529	371	527	313	525	269	522	224	518	180	---	---	---	---	---	---
	72	54.9	508	417	505	359	504	316	502	272	500	228	495	183	---	---	---	---
	67	53.8	481	481	472	437	470	394	468	350	467	307	465	263	462	219	457	174
	62	52.8	480	480	461	461	447	447	436	421	434	383	432	340	430	296	428	253
	57	52.4	479	479	460	460	446	446	432	432	418	418	405	405	400	371	397	328
14000	75	55.7	533	388	532	325	529	278	526	230	522	182	---	---	---	---	---	---
	72	55	513	438	510	375	509	328	507	281	504	234	499	185	---	---	---	---
	67	53.9	491	491	478	455	475	410	472	365	471	318	469	271	466	223	461	175
	62	52.8	490	490	471	471	456	456	442	440	439	399	436	354	434	307	432	260
	57	52.7	489	489	470	470	456	456	441	441	427	427	413	413	404	384	402	341
15000	75	55.8	537	404	535	338	533	287	530	236	525	184	---	---	---	---	---	---
	72	55.1	518	455	514	391	512	341	510	290	507	239	503	188	---	---	---	---
	67	54	501	501	483	472	479	425	476	378	475	329	472	279	469	228	464	176
	62	53.2	500	500	480	480	465	465	451	451	443	413	440	364	438	316	436	267
	57	52.9	500	500	479	479	464	464	449	449	435	435	420	420	409	397	406	351
16000	75	55.9	542	421	539	350	537	296	533	242	526	186	---	---	---	---	---	---
	72	55.2	522	473	518	406	516	353	514	299	510	245	506	190	---	---	---	---
	67	53.9	509	509	489	489	483	441	481	392	478	341	476	287	472	232	467	177
	62	53.4	509	509	488	488	473	473	458	458	447	426	444	375	442	326	439	274
	57	53.2	508	508	487	487	472	472	457	457	442	442	427	427	413	408	409	362
17000	75	56	545	435	542	363	539	305	536	247	529	188	---	---	---	---	---	---
	72	55.3	526	488	521	418	519	364	517	308	513	251	507	192	---	---	---	---
	67	54.3	517	517	496	496	487	455	484	403	481	348	479	294	475	237	469	178
	62	53.4	517	517	496	496	480	480	464	464	451	437	448	388	445	335	442	279
	57	53.4	516	516	495	495	479	479	464	464	448	448	433	433	419	419	413	372
18000	75	56.1	548	449	545	374	542	314	538	253	532	191	---	---	---	---	---	---
	72	55.4	530	504	524	431	521	374	519	317	516	256	509	194	---	---	---	---
	67	54.4	524	524	503	503	491	468	487	414	484	358	481	301	477	241	471	179
	62	53.6	524	524	502	502	486	486	470	470	455	450	451	399	447	343	444	284
	57	53.6	523	523	502	502	486	486	470	470	454	454	439	439	424	424	416	382
19000	75	56.1	551	462	547	384	544	322	541	259	535	193	---	---	---	---	---	---
	72	55.5	533	521	527	444	524	384	522	324	518	262	511	196	---	---	---	---
	67	54.5	531	531	509	509	494	484	489	426	486	367	483	307	480	246	473	180
	62	53.8	530	530	509	509	493	493	476	476	461	461	453	410	450	351	447	289
	57	53.8	530	530	508	508	492	492	476	476	460	460	444	444	429	429	418	390
20000	75	56.2	554	476	550	394	547	331	543	264	537	195	---	---	---	---	---	---
	72	55.6	537	533	530	456	526	394	524	331	520	268	514	199	---	---	---	---
	67	54.5	537	537	515	515	498	494	492	437	488	375	486	313	482	250	475	181
	62	54.2	536	536	514	514	498	498	482	482	466	466	455	419	452	359	449	294
	57	54.1	536	536	514	514	497	497	481	481	465	465	449	449	433	433	420	398

TABLE 30: COOLING PERFORMANCE - 40 TON STANDARD CAPACITY COIL (CONTINUED)

AIR ON EVAPORATOR COIL		115 °F AIR ON CONDENSER COIL																
		POWER INPUT KW	CAPACITY (MBH) AT ENTERING DRY BULB (F)															
			90		86		83		80		77		74		71		68	
CFM	WB°F	TOT	SEN	TOT	SEN	TOT	SEN	TOT	SEN	TOT	SEN	TOT	SEN	TOT	SEN	TOT	SEN	
8000	75	60.7	468	277	467	241	465	214	464	187	461	159	---	---	---	---	---	---
	72	60	447	306	446	271	445	244	443	217	442	190	439	163	---	---	---	---
	67	58.5	413	354	411	319	410	292	410	266	409	239	408	212	406	185	404	158
	62	57.5	388	388	379	365	379	339	377	312	377	286	376	259	375	233	374	206
	57	56.5	388	388	373	373	362	362	351	351	346	330	346	304	345	278	344	251
9000	75	61.1	478	294	476	254	475	224	473	193	470	162	---	---	---	---	---	---
	72	60.3	457	327	456	287	455	257	453	227	451	196	448	165	---	---	---	---
	67	59.1	424	381	421	341	421	311	419	281	418	251	417	221	415	190	412	159
	62	57.7	407	407	391	391	388	363	387	334	386	304	385	274	384	244	383	214
	57	57.1	406	406	391	391	379	379	367	367	357	355	355	325	354	295	353	265
10000	75	61.4	486	311	484	267	483	233	480	199	477	164	---	---	---	---	---	---
	72	60.3	465	347	464	303	462	270	461	236	459	202	455	168	---	---	---	---
	67	59.4	432	407	430	363	429	330	427	296	426	263	425	229	423	195	419	161
	62	57.9	423	423	406	406	398	388	396	355	394	321	393	288	392	255	390	222
	57	57.6	422	422	406	406	393	393	381	381	369	369	363	345	362	312	361	279
11000	75	61.6	492	328	491	279	489	242	487	205	483	167	---	---	---	---	---	---
	72	60.6	472	368	470	319	469	282	467	245	465	208	461	170	---	---	---	---
	67	59.3	441	434	437	385	436	348	434	311	433	275	431	238	429	200	425	162
	62	58.4	437	437	419	419	407	407	402	376	401	339	400	303	398	266	397	229
	57	58.1	436	436	419	419	406	406	393	393	381	381	370	365	369	329	367	292
12000	75	61.5	498	345	497	292	494	251	492	210	487	169	---	---	---	---	---	---
	72	61.1	479	389	475	335	475	295	472	254	470	214	466	172	---	---	---	---
	67	59.5	450	450	443	406	442	366	440	326	438	286	436	246	434	205	429	163
	62	58.4	449	449	431	431	418	418	409	395	407	357	405	316	403	276	402	236
	57	58.5	448	448	431	431	417	417	404	404	391	391	378	378	374	344	372	305
13000	75	61.7	503	362	501	304	499	260	496	216	491	171	---	---	---	---	---	---
	72	61.2	483	409	481	351	479	307	477	263	474	219	470	174	---	---	---	---
	67	60	461	461	449	427	447	385	444	341	443	297	441	254	438	209	433	165
	62	58.6	460	460	441	441	427	427	416	414	412	372	410	330	408	287	406	243
	57	58.8	459	459	441	441	427	427	414	414	400	400	387	387	379	358	377	318
14000	75	61.9	507	379	505	317	503	269	500	222	495	173	---	---	---	---	---	---
	72	61.4	488	429	485	367	483	320	481	272	478	225	473	177	---	---	---	---
	67	59.9	471	471	455	445	452	402	449	356	447	309	445	262	442	214	437	166
	62	59.2	470	470	450	450	436	436	423	423	416	386	414	344	412	297	410	250
	57	59.1	469	469	450	450	436	436	422	422	408	408	395	395	384	372	381	330
15000	75	62	511	396	509	329	506	279	503	227	498	176	---	---	---	---	---	---
	72	61.5	492	446	489	383	487	332	484	282	481	231	476	179	---	---	---	---
	67	60.3	479	479	460	460	455	416	452	369	451	320	448	270	445	219	439	167
	62	59.4	478	478	459	459	444	444	431	431	421	400	418	356	416	308	413	257
	57	59.1	478	478	458	458	444	444	429	429	416	416	402	402	388	384	385	341
16000	75	62.1	515	412	512	342	509	288	506	233	499	177	---	---	---	---	---	---
	72	61.6	497	464	492	397	490	345	487	291	484	236	479	181	---	---	---	---
	67	60.4	487	487	467	467	459	432	456	381	453	330	451	278	447	223	441	167
	62	59.7	486	486	466	466	452	452	437	437	424	414	421	367	419	316	416	264
	57	59.4	486	486	466	466	451	451	436	436	422	422	408	408	394	394	388	351
17000	75	62.2	518	426	515	354	512	297	509	239	503	180	---	---	---	---	---	---
	72	61.7	501	479	495	410	492	355	490	300	487	242	481	183	---	---	---	---
	67	60.3	494	494	475	475	463	444	459	394	456	339	454	285	450	228	442	168
	62	59.6	494	494	473	473	458	458	443	443	429	429	424	378	421	323	419	271
	57	59.6	493	493	473	473	458	458	443	443	428	428	414	414	399	399	391	361
18000	75	62.6	521	439	517	365	514	306	511	245	505	182	---	---	---	---	---	---
	72	61.8	504	496	498	422	495	367	492	307	489	248	483	186	---	---	---	---
	67	60.7	501	501	481	481	466	460	462	404	458	348	456	291	452	232	444	169
	62	59.9	500	500	480	480	464	464	449	449	434	434	427	389	423	331	421	276
	57	59.8	500	500	479	479	464	464	448	448	433	433	419	419	404	404	393	371
19000	75	62.6	523	453	519	375	516	313	513	250	506	185	---	---	---	---	---	---
	72	61.9	508	508	501	434	497	375	495	314	491	253	485	188	---	---	---	---
	67	60.8	507	507	486	486	471	471	464	416	460	357	458	297	454	237	442	169
	62	60.1	507	507	485	485	470	470	454	454	439	439	429	398	425	339	423	281
	57	60	506	506	485	485	469	469	454	454	438	438	423	423	408	408	396	378
20000	75	62.7	526	466	522	385	518	320	514	256	508	187	---	---	---	---	---	---
	72	62	514	514	503	447	499	385	496	321	493	259	486	190	---	---	---	---
	67	60.6	513	513	491	491	475	475	467	429	462	366	460	303	456	241	447	171
	62	60.2	512	512	491	491	475	475	459	459	444	444	432	407	427	347	425	286
	57	60.2	512	512	490	490	474	474	458	458	443	443	427	427	412	412	398	386

TABLE 31: COOLING PERFORMANCE - 40 TON HIGH CAPACITY COIL

AIR ON EVAPORATOR COIL		85 °F AIR ON CONDENSER COIL																
		POWER INPUT KW	CAPACITY (MBH) AT ENTERING DRY BULB (F)															
			90		86		83		80		77		74		71		68	
CFM	WB°F	TOT	SEN	TOT	SEN	TOT	SEN	TOT	SEN	TOT	SEN	TOT	SEN	TOT	SEN	TOT	SEN	
8000	75	44.0	543	305	542	270	541	243	539	216	537	188	---	---	---	---	---	---
	72	43.4	518	335	517	300	516	273	515	246	514	219	512	192	---	---	---	---
	67	42.4	477	383	476	348	476	322	476	295	475	269	474	242	473	215	471	188
	62	41.6	440	430	440	395	438	368	437	342	437	316	437	289	436	263	435	236
	57	40.8	437	437	421	421	409	409	401	386	402	360	401	334	401	308	400	281
9000	75	44.3	557	323	555	283	554	252	552	222	549	191	---	---	---	---	---	---
	72	43.7	531	356	531	316	530	286	528	256	527	226	524	195	---	---	---	---
	67	42.8	492	410	490	371	489	341	489	311	488	281	487	251	485	221	483	190
	62	41.9	460	460	454	424	452	394	450	364	450	334	450	305	449	275	447	245
	57	41.2	460	460	443	443	430	430	418	416	416	386	414	355	413	326	412	296
10000	75	44.6	567	340	566	295	565	262	562	228	559	193	---	---	---	---	---	---
	72	44.0	543	377	542	333	541	299	539	266	537	232	534	197	---	---	---	---
	67	43.0	504	438	501	393	500	360	500	327	499	294	498	260	496	226	493	192
	62	42.2	480	480	465	452	464	419	462	386	461	353	460	320	459	286	458	253
	57	41.6	480	480	462	462	448	448	435	435	426	409	425	377	423	343	423	310
11000	75	44.8	577	357	575	308	573	271	571	233	567	196	---	---	---	---	---	---
	72	44.2	552	397	551	349	550	312	548	275	546	238	542	200	---	---	---	---
	67	43.3	514	464	511	415	509	378	509	342	508	305	506	269	504	231	501	193
	62	42.4	498	498	478	478	472	443	472	407	470	371	469	334	468	298	466	261
	57	42.0	497	497	478	478	464	464	451	451	437	434	435	398	433	361	431	324
12000	75	45.0	584	374	583	321	581	280	578	239	574	198	---	---	---	---	---	---
	72	44.4	560	418	558	365	557	325	555	284	553	243	549	202	---	---	---	---
	67	43.4	522	490	520	437	518	397	517	357	515	317	514	277	511	236	507	195
	62	42.6	513	513	494	494	482	468	480	428	478	388	477	348	475	308	474	268
	57	42.3	513	513	493	493	479	479	465	465	450	450	441	417	440	378	439	338
13000	75	45.1	591	391	589	333	587	289	584	245	580	200	---	---	---	---	---	---
	72	44.6	568	438	565	380	564	337	562	293	559	249	555	204	---	---	---	---
	67	43.6	531	517	527	459	525	415	523	372	522	329	520	285	517	241	513	196
	62	42.7	527	527	507	507	492	492	487	449	485	406	483	362	482	319	480	275
	57	42.6	527	527	507	507	492	492	477	477	462	462	449	437	447	395	445	351
14000	75	45.3	596	408	595	345	592	298	589	251	585	202	---	---	---	---	---	---
	72	44.7	574	459	570	396	569	349	567	302	564	255	560	207	---	---	---	---
	67	43.7	540	540	534	481	531	434	529	387	527	340	525	293	522	246	518	197
	62	42.9	540	540	519	519	504	504	493	470	492	423	489	376	487	330	485	283
	57	42.9	539	539	519	519	503	503	488	488	473	473	456	455	453	411	450	364
15000	75	45.4	602	425	599	358	597	307	594	256	589	204	---	---	---	---	---	---
	72	44.8	579	479	575	412	574	362	572	311	569	260	564	209	---	---	---	---
	67	43.8	552	552	539	502	537	452	534	402	532	351	530	301	527	250	522	198
	62	43.0	551	551	530	530	514	514	500	488	497	441	493	390	492	340	490	290
	57	43.1	551	551	529	529	514	514	498	498	482	482	467	467	458	427	455	377
16000	75	45.5	605	442	603	370	601	316	598	262	592	207	---	---	---	---	---	---
	72	44.9	585	500	579	428	578	374	576	320	573	266	568	211	---	---	---	---
	67	43.9	562	562	545	521	542	470	538	416	536	363	534	309	531	255	525	199
	62	43.2	562	562	540	540	524	524	506	505	502	457	499	404	496	350	494	297
	57	43.3	561	561	539	539	523	523	507	507	491	491	475	475	462	441	460	390
17000	75	45.6	610	459	607	383	605	325	601	267	595	209	---	---	---	---	---	---
	72	45.0	589	520	584	444	582	387	580	329	576	272	571	213	---	---	---	---
	67	44.1	572	572	550	541	546	487	543	431	540	374	538	317	534	259	528	200
	62	43.5	571	571	549	549	532	532	516	516	505	472	503	418	500	361	497	304
	57	43.5	570	570	548	548	532	532	515	515	499	499	482	482	467	454	464	403
18000	75	45.7	615	476	610	395	608	334	604	273	598	211	---	---	---	---	---	---
	72	45.1	592	538	588	459	585	399	583	338	579	277	574	215	---	---	---	---
	67	44.2	580	580	557	557	549	503	546	446	543	385	541	325	537	264	531	201
	62	43.7	580	580	557	557	540	540	523	523	510	485	506	430	503	371	500	311
	57	43.7	579	579	556	556	539	539	523	523	506	506	489	489	471	466	468	413
19000	75	45.8	618	493	613	408	611	343	607	279	600	213	---	---	---	---	---	---
	72	45.1	597	555	591	475	588	411	586	347	582	283	576	217	---	---	---	---
	67	44.3	588	588	565	565	553	517	550	458	547	397	544	333	540	268	533	203
	62	43.9	588	588	564	564	547	547	530	530	514	499	510	441	506	381	503	317
	57	43.8	587	587	564	564	546	546	529	529	512	512	496	496	479	479	471	423
20000	75	45.8	622	510	616	420	614	353	609	284	603	215	---	---	---	---	---	---
	72	45.2	601	572	594	488	591	424	588	356	584	288	578	220	---	---	---	---
	67	44.4	596	596	572	572	557	532	553	470	549	408	547	341	542	273	535	204
	62	44.0	595	595	571	571	554	554	536	536	517	513	513	452	509	389	506	324
	57	44.0	594	594	571	571	553	553	536	536	518	518	501	501	484	484	474	433

TABLE 31: COOLING PERFORMANCE - 40 TON HIGH CAPACITY COIL (CONTINUED)

AIR ON EVAPORATOR COIL		95 °F AIR ON CONDENSER COIL																
		POWER INPUT KW	CAPACITY (MBH) AT ENTERING DRY BULB (F)															
			90		86		83		80		77		74		71		68	
CFM	WB°F	TOT	SEN	TOT	SEN	TOT	SEN	TOT	SEN	TOT	SEN	TOT	SEN	TOT	SEN	TOT	SEN	
8000	75	49	522	297	520	261	519	235	518	207	515	180	---	---	---	---	---	
	72	48.4	497	327	497	291	496	265	495	238	493	211	491	184	---	---	---	
	67	47.2	458	374	458	339	457	313	457	287	456	260	455	233	454	206	452	179
	62	46.2	423	421	422	386	421	359	420	333	420	307	419	280	418	254	417	227
	57	45.4	423	423	408	408	396	396	386	378	386	351	385	325	384	299	384	272
9000	75	49.4	534	314	533	274	531	244	529	213	527	183	---	---	---	---	---	
	72	48.7	510	348	509	308	508	278	507	248	505	217	503	186	---	---	---	
	67	47.5	473	402	470	362	470	332	469	303	468	273	467	242	465	212	463	181
	62	46.5	445	445	434	414	434	385	433	355	432	325	431	296	430	266	429	236
	57	45.9	444	444	428	428	416	416	403	403	397	375	397	347	396	317	395	287
10000	75	49.7	544	332	543	287	541	253	539	219	536	185	---	---	---	---	---	
	72	48.8	521	368	519	324	518	291	517	257	515	223	512	189	---	---	---	
	67	47.8	483	429	481	384	480	351	479	318	478	285	477	251	475	217	472	183
	62	46.8	464	464	447	444	445	410	443	377	442	344	441	310	440	277	438	244
	57	46.4	463	463	445	445	432	432	420	420	408	401	407	368	405	334	405	301
11000	75	49.7	553	349	551	300	549	263	547	225	543	187	---	---	---	---	---	
	72	49.1	529	389	528	340	527	303	525	266	522	229	519	191	---	---	---	
	67	48	491	455	491	407	489	370	488	333	486	296	485	259	482	222	479	184
	62	47.1	480	480	462	462	453	434	453	398	450	361	449	325	448	288	446	251
	57	46.6	480	480	462	462	447	447	434	434	421	421	416	388	414	352	412	315
12000	75	49.9	560	366	558	312	556	272	553	231	550	189	---	---	---	---	---	
	72	49.2	537	409	535	356	533	316	532	275	529	235	525	193	---	---	---	
	67	48.2	501	482	499	428	496	388	495	348	493	308	491	268	489	227	485	185
	62	47.3	495	495	476	476	463	460	460	419	458	379	456	339	455	299	453	259
	57	46.9	495	495	476	476	462	462	447	447	434	434	423	408	421	368	419	328
13000	75	50.1	566	383	564	325	561	281	559	236	555	192	---	---	---	---	---	
	72	49.4	544	430	540	372	539	328	537	285	534	240	531	196	---	---	---	
	67	48.4	510	508	506	450	503	407	501	363	499	320	497	276	494	232	490	187
	62	47.4	509	509	489	489	474	474	466	440	464	397	462	353	460	310	458	266
	57	47.4	508	508	488	488	474	474	459	459	444	444	430	428	428	385	425	341
14000	75	50.2	571	400	569	337	566	290	564	242	559	194	---	---	---	---	---	
	72	49.5	549	450	546	387	544	341	542	294	539	246	535	198	---	---	---	
	67	48.5	521	521	510	471	509	425	506	378	504	331	502	284	499	236	494	188
	62	47.6	521	521	500	500	485	485	473	460	470	414	467	367	466	320	463	273
	57	47.7	520	520	500	500	484	484	469	469	455	455	440	440	433	402	430	354
15000	75	50.3	575	416	573	349	571	299	568	248	563	196	---	---	---	---	---	
	72	49.7	555	471	550	403	549	353	547	303	543	252	539	200	---	---	---	
	67	48.6	532	532	516	491	514	443	510	392	509	342	506	292	503	241	498	189
	62	47.8	531	531	510	510	495	495	479	478	475	431	472	381	470	331	467	280
	57	47.9	531	531	510	510	494	494	479	479	464	464	448	448	437	416	435	368
16000	75	50.4	580	434	577	362	575	308	571	253	566	198	---	---	---	---	---	
	72	49.8	560	491	555	419	553	366	550	312	547	257	542	202	---	---	---	
	67	48.8	542	542	521	511	518	461	515	407	513	354	510	300	506	245	501	190
	62	48.2	541	541	520	520	504	504	488	488	479	447	476	395	474	341	471	287
	57	48.2	540	540	519	519	503	503	487	487	472	472	456	456	442	430	439	380
17000	75	50.5	585	451	580	374	578	317	574	259	569	200	---	---	---	---	---	
	72	49.9	563	511	559	435	556	378	554	321	550	263	545	205	---	---	---	
	67	48.9	551	551	529	529	521	478	519	422	516	365	513	308	510	250	504	191
	62	48.4	550	550	528	528	512	512	496	496	483	458	480	408	477	351	474	294
	57	48.4	549	549	527	527	511	511	495	495	479	479	463	463	446	442	443	392
18000	75	50.8	588	468	584	387	581	326	577	265	571	203	---	---	---	---	---	
	72	50	567	527	563	451	559	390	557	330	553	269	547	206	---	---	---	
	67	49	559	559	536	536	525	492	522	436	519	376	516	316	512	254	507	192
	62	48.6	558	558	536	536	519	519	503	503	487	472	484	421	480	361	477	301
	57	48.6	557	557	535	535	518	518	502	502	486	486	469	469	453	453	446	403
19000	75	50.8	591	485	586	399	584	335	580	270	574	205	---	---	---	---	---	
	72	50	571	543	566	467	562	403	559	339	556	274	549	209	---	---	---	
	67	49.1	566	566	543	543	529	505	525	448	522	387	519	324	515	259	510	194
	62	48.8	565	565	543	543	526	526	509	509	491	486	487	432	483	371	480	308
	57	48.8	565	565	542	542	525	525	508	508	492	492	475	475	459	459	448	409
20000	75	50.9	594	499	589	412	586	344	582	276	576	207	---	---	---	---	---	
	72	50.1	575	564	569	481	564	415	562	348	558	280	551	211	---	---	---	
	67	49.2	573	573	550	550	533	524	528	461	524	399	521	331	517	263	510	194
	62	48.9	572	572	549	549	532	532	515	515	498	498	489	439	485	380	482	315
	57	48.9	572	572	548	548	531	531	514	514	497	497	481	481	464	464	451	423

TABLE 31: COOLING PERFORMANCE - 40 TON HIGH CAPACITY COIL (CONTINUED)

AIR ON EVAPORATOR COIL		105 °F AIR ON CONDENSER COIL																
		POWER INPUT KW	CAPACITY (MBH) AT ENTERING DRY BULB (F)															
			90		86		83		80		77		74		71		68	
CFM	WB°F	TOT	SEN	TOT	SEN	TOT	SEN	TOT	SEN	TOT	SEN	TOT	SEN	TOT	SEN	TOT	SEN	
8000	75	54.7	499	288	498	253	497	226	495	199	493	171	---	---	---	---	---	---
	72	54	476	318	475	283	474	256	473	229	472	202	470	175	---	---	---	---
	67	52.6	439	366	438	330	438	304	437	278	436	251	435	224	434	197	432	170
	62	51.5	408	408	405	377	403	351	402	324	401	298	401	271	400	245	399	218
	57	50.5	409	409	393	393	382	382	370	369	369	343	368	316	367	290	367	263
9000	75	55	510	306	509	266	508	235	506	205	503	174	---	---	---	---	---	---
	72	54.1	487	339	487	299	486	269	484	239	483	208	480	177	---	---	---	---
	67	53	452	393	450	353	449	323	448	293	447	264	446	233	444	203	442	172
	62	51.9	429	429	415	405	415	376	413	346	413	316	412	286	411	257	410	226
	57	51.3	429	429	412	412	400	400	388	388	380	367	380	338	378	308	377	278
10000	75	55.3	520	323	518	278	517	245	515	211	511	176	---	---	---	---	---	---
	72	54.6	496	359	495	315	495	282	493	248	491	214	488	180	---	---	---	---
	67	53.2	462	420	460	375	459	342	457	309	456	275	455	242	453	208	450	174
	62	52.2	446	446	429	429	424	400	423	368	422	334	421	301	420	268	418	234
	57	51.7	446	446	429	429	416	416	404	404	391	391	389	358	387	325	386	292
11000	75	55.5	527	340	526	291	524	254	522	216	518	179	---	---	---	---	---	---
	72	54.9	506	380	503	331	502	294	501	257	498	220	495	182	---	---	---	---
	67	53.5	470	446	468	397	466	360	465	324	464	287	462	250	460	213	456	175
	62	52.4	462	462	445	445	433	425	432	389	430	352	428	315	427	279	425	242
	57	52.2	462	462	444	444	430	430	418	418	405	405	396	378	395	342	393	305
12000	75	55.7	533	357	532	303	530	263	528	222	524	181	---	---	---	---	---	---
	72	55.1	513	401	509	347	508	307	507	267	504	226	501	184	---	---	---	---
	67	53.7	479	473	476	419	474	379	472	339	470	299	468	258	466	218	462	176
	62	52.7	476	476	457	457	444	444	437	409	437	370	435	329	433	290	431	249
	57	52.4	476	476	457	457	443	443	429	429	416	416	404	399	402	359	399	319
13000	75	55.9	539	374	537	316	535	272	533	228	528	183	---	---	---	---	---	---
	72	55.2	519	421	515	363	514	319	512	276	509	231	505	187	---	---	---	---
	67	53.9	490	490	480	440	480	397	477	354	476	310	474	267	471	222	466	177
	62	53	489	489	469	469	455	455	444	429	443	387	440	343	438	300	437	256
	57	52.7	488	488	469	469	454	454	440	440	426	426	413	413	407	375	405	332
14000	75	56.1	544	391	542	328	540	281	537	234	532	185	---	---	---	---	---	---
	72	55.4	523	441	520	379	518	332	516	285	514	237	509	189	---	---	---	---
	67	54	501	501	487	463	485	416	482	368	480	322	478	274	475	227	470	179
	62	53.1	500	500	480	480	465	465	451	449	448	405	445	357	443	311	441	263
	57	53	499	499	479	479	464	464	450	450	435	435	421	421	412	391	410	345
15000	75	56.2	549	408	546	341	544	290	541	239	534	187	---	---	---	---	---	---
	72	55.5	529	462	524	395	522	344	520	294	517	243	513	191	---	---	---	---
	67	54.2	511	511	492	483	490	434	486	383	484	333	482	282	479	232	473	180
	62	53.5	510	510	489	489	474	474	460	460	452	421	450	371	447	321	445	270
	57	53.3	510	510	489	489	474	474	459	459	444	444	429	429	417	405	414	358
16000	75	56.3	554	425	550	353	547	299	544	245	537	189	---	---	---	---	---	---
	72	55.6	533	482	528	410	526	357	524	303	521	248	514	193	---	---	---	---
	67	54.3	520	520	499	499	492	450	491	398	488	344	485	290	482	236	476	181
	62	53.7	520	520	498	498	482	482	468	468	456	434	454	385	451	331	448	277
	57	53.5	519	519	497	497	482	482	466	466	451	451	436	436	421	417	418	370
17000	75	56.4	557	443	553	366	550	308	547	251	540	192	---	---	---	---	---	---
	72	55.7	537	500	532	426	529	369	527	312	523	254	517	195	---	---	---	---
	67	54.4	528	528	507	507	497	465	494	413	490	355	488	298	485	241	478	182
	62	53.8	528	528	506	506	490	490	474	474	461	450	457	398	454	341	451	284
	57	53.7	527	527	506	506	489	489	474	474	458	458	443	443	428	428	421	381
18000	75	56.5	560	459	556	378	553	318	549	256	543	194	---	---	---	---	---	---
	72	55.8	541	517	536	443	532	381	530	321	526	260	519	197	---	---	---	---
	67	54.7	536	536	514	514	501	480	497	424	493	367	491	306	487	245	481	183
	62	54	535	535	513	513	497	497	481	481	465	465	460	409	456	352	454	291
	57	53.9	535	535	513	513	496	496	480	480	464	464	448	448	433	433	424	390
19000	75	56.2	563	475	558	391	556	327	551	262	545	196	---	---	---	---	---	---
	72	55.9	545	535	539	458	534	394	532	330	528	265	522	200	---	---	---	---
	67	54.8	543	543	521	521	505	496	500	437	496	376	493	314	489	249	482	184
	62	54.1	542	542	520	520	503	503	487	487	471	471	463	420	459	361	456	298
	57	54.1	542	542	519	519	503	503	486	486	470	470	454	454	438	438	426	399
20000	75	56.6	566	490	561	403	558	336	554	268	547	199	---	---	---	---	---	---
	72	56	550	550	542	471	537	405	534	339	530	271	524	202	---	---	---	---
	67	55.2	549	549	527	527	510	510	501	448	498	386	495	321	491	254	484	185
	62	54.6	549	549	526	526	509	509	493	493	476	476	465	429	461	369	458	305
	57	54.5	548	548	525	525	509	509	492	492	476	476	459	459	443	443	429	408

TABLE 31: COOLING PERFORMANCE - 40 TON HIGH CAPACITY COIL (CONTINUED)

AIR ON EVAPORATOR COIL		115 °F AIR ON CONDENSER COIL																
		POWER INPUT KW	CAPACITY (MBH) AT ENTERING DRY BULB (F)															
			90		86		83		80		77		74		71		68	
CFM	WB°F	TOT	SEN	TOT	SEN	TOT	SEN	TOT	SEN	TOT	SEN	TOT	SEN	TOT	SEN	TOT	SEN	
8000	75	61.1	476	280	475	244	473	217	472	190	469	163	---	---	---	---	---	
	72	60.3	454	309	453	274	452	247	451	220	450	193	447	166	---	---	---	
	67	59	419	357	417	321	417	295	416	269	416	242	415	215	413	188	411	161
	62	57.7	393	393	384	367	385	342	383	315	382	288	382	262	381	236	380	209
	57	56.7	393	393	378	378	367	367	356	356	350	333	351	307	350	281	349	254
9000	75	61.5	487	297	485	257	484	227	482	196	479	165	---	---	---	---	---	
	72	60.7	464	330	464	290	463	260	461	230	459	199	457	168	---	---	---	
	67	59.4	431	384	428	344	427	314	426	284	426	254	424	224	423	194	420	163
	62	57.9	412	412	396	396	395	367	394	337	392	307	392	277	391	247	390	217
	57	57.3	412	412	396	396	384	384	373	373	363	358	361	328	360	298	359	268
10000	75	61.8	494	314	493	270	492	236	489	202	486	167	---	---	---	---	---	
	72	60.7	473	350	472	306	471	273	469	239	467	205	464	171	---	---	---	
	67	59.4	439	410	438	366	436	333	435	300	434	266	432	233	430	199	427	164
	62	58.2	429	429	412	412	404	391	403	358	401	325	400	292	399	258	397	225
	57	57.9	429	429	412	412	400	400	387	387	375	375	368	348	368	316	367	282
11000	75	62	501	331	500	282	498	245	496	208	492	170	---	---	---	---	---	
	72	61	481	371	478	322	477	285	476	248	474	211	470	173	---	---	---	
	67	59.7	448	437	446	388	444	351	442	315	441	278	439	241	437	203	433	166
	62	58.9	444	444	427	427	413	413	409	379	408	342	406	306	406	269	404	232
	57	58.3	443	443	426	426	413	413	400	400	387	387	377	369	375	332	373	296
12000	75	61.9	507	348	506	295	504	254	501	213	497	172	---	---	---	---	---	
	72	61.5	488	392	484	338	483	298	481	258	479	217	475	175	---	---	---	
	67	59.9	458	458	451	409	450	370	448	329	447	289	445	249	442	208	438	167
	62	59	457	457	438	438	425	425	416	400	414	360	412	320	411	280	409	239
	57	58.8	456	456	438	438	425	425	411	411	398	398	385	385	381	349	379	309
13000	75	62.1	513	366	511	307	509	263	506	219	501	174	---	---	---	---	---	
	72	61.6	493	412	490	354	488	310	486	267	484	222	479	178	---	---	---	
	67	60.1	469	469	457	431	456	388	453	344	451	301	449	257	446	213	442	168
	62	59.2	468	468	449	449	436	436	423	420	420	377	417	334	416	290	414	247
	57	59.1	468	468	449	449	435	435	421	421	408	408	394	394	386	365	384	322
14000	75	62.3	517	383	515	320	513	273	510	225	505	176	---	---	---	---	---	
	72	61.8	498	433	494	370	493	323	490	276	487	228	483	180	---	---	---	
	67	60.5	480	480	464	453	461	406	457	359	455	312	453	265	450	217	445	169
	62	59.5	479	479	459	459	445	445	431	431	424	394	422	348	420	301	418	254
	57	59.5	478	478	459	459	444	444	431	431	416	416	402	402	391	380	388	335
15000	75	62.7	522	400	519	332	516	282	513	231	507	179	---	---	---	---	---	
	72	61.9	502	453	499	386	496	335	494	285	491	234	486	182	---	---	---	
	67	60.4	489	489	469	469	464	424	462	374	459	324	457	273	453	222	447	169
	62	59.8	488	488	468	468	453	453	439	439	429	408	426	361	424	311	421	260
	57	59.5	488	488	468	468	453	453	438	438	424	424	410	410	395	395	392	348
16000	75	62.8	525	417	522	345	519	291	516	236	510	181	---	---	---	---	---	
	72	62.1	506	474	502	402	499	348	497	294	494	239	488	184	---	---	---	
	67	60.8	497	497	477	477	468	442	465	389	462	335	460	281	456	227	448	170
	62	60.1	497	497	476	476	461	461	446	446	433	425	429	373	427	321	424	267
	57	59.8	496	496	476	476	460	460	445	445	430	430	416	416	402	402	396	359
17000	75	62.9	529	434	525	357	522	300	518	242	512	183	---	---	---	---	---	
	72	62.2	510	490	505	418	502	360	500	303	496	245	490	186	---	---	---	
	67	60.7	505	505	485	485	472	455	469	404	465	346	462	289	459	231	450	171
	62	60	504	504	483	483	468	468	453	453	438	438	433	385	429	330	427	274
	57	60	504	504	483	483	467	467	452	452	437	437	422	422	407	407	398	368
18000	75	63	532	451	527	370	524	309	521	248	514	185	---	---	---	---	---	
	72	62.3	515	510	508	432	504	372	502	312	499	251	492	189	---	---	---	
	67	61.1	512	512	491	491	476	472	471	414	467	357	465	297	461	235	452	172
	62	60.2	511	511	490	490	474	474	458	458	444	444	436	398	431	339	429	281
	57	60.2	511	511	489	489	474	474	458	458	442	442	427	427	412	412	401	380
19000	75	63.1	534	465	530	382	527	318	523	253	515	187	---	---	---	---	---	
	72	62.3	520	520	511	446	507	385	504	321	500	256	493	190	---	---	---	
	67	61.1	518	518	497	497	481	481	473	428	470	367	467	305	463	240	455	174
	62	60.5	518	518	496	496	480	480	464	464	449	449	438	408	434	348	431	288
	57	60.4	517	517	496	496	479	479	464	464	448	448	432	432	417	417	404	389
20000	75	63.1	537	480	532	395	529	327	525	259	517	190	---	---	---	---	---	
	72	62.4	526	526	513	460	509	396	506	330	502	262	495	193	---	---	---	
	67	61	524	524	502	502	486	486	477	441	472	376	469	311	465	244	458	175
	62	60.6	524	524	502	502	485	485	469	469	453	453	441	420	436	356	433	294
	57	60.6	523	523	501	501	485	485	469	469	453	453	437	437	421	421	407	399

CFM, STATIC PRESSURE, AND POWER - ALTI- TITUDE AND TEMPERATURE CORRECTIONS

The information below should be used to assist in application of product when being applied at altitudes at or exceeding 1000 feet above sea level.

The air flow rates listed in the standard blower performance tables are based on standard air at sea level. As the altitude or temperature increases, the density of air decreases. In

order to use the indoor blower tables for high altitude applications, certain corrections are necessary.

A centrifugal fan is a "constant volume" device. This means that, if the rpm remains constant, the CFM delivered is the same regardless of the density of the air. However, since the air at high altitude is less dense, less static pressure will be generated and less power will be required than a similar application at sea level. Air density correction factors are shown in Table 32 and Figure 21.

TABLE 32: ALTITUDE CORRECTION FACTORS

AIR TEMP	ALTITUDE (FEET)										
	0	1000	2000	3000	4000	5000	6000	7000	8000	9000	10000
40	1.060	1.022	0.986	0.950	0.916	0.882	0.849	0.818	0.788	0.758	0.729
50	1.039	1.002	0.966	0.931	0.898	0.864	0.832	0.802	0.772	0.743	0.715
60	1.019	0.982	0.948	0.913	0.880	0.848	0.816	0.787	0.757	0.729	0.701
70	1.000	0.964	0.930	0.896	0.864	0.832	0.801	0.772	0.743	0.715	0.688
80	0.982	0.947	0.913	0.880	0.848	0.817	0.787	0.758	0.730	0.702	0.676
90	0.964	0.929	0.897	0.864	0.833	0.802	0.772	0.744	0.716	0.689	0.663
100	0.946	0.912	0.880	0.848	0.817	0.787	0.758	0.730	0.703	0.676	0.651

The examples below will assist in determining the airflow performance of the product at altitude.

Example 1: What are the corrected CFM, static pressure, and BHP at an elevation of 5,000 ft. if the blower performance data is 6,000 CFM, 1.5 IWC and 4.0 BHP?

Solution: At an elevation of 5,000 ft the indoor blower will still deliver 6,000 CFM if the rpm is unchanged. However, Table 32 must be used to determine the static pressure and BHP. Since no temperature data is given, we will assume an air temperature of 70°F. Table 32 shows the correction factor to be 0.832.

$$\text{Corrected static pressure} = 1.5 \times 0.832 = 1.248 \text{ IWC}$$

$$\text{Corrected BHP} = 4.0 \times 0.832 = 3.328$$

Example 2: A system, located at 5,000 feet of elevation, is to deliver 6,000 CFM at a static pressure of 1.5". Use the unit

blower tables to select the blower speed and the BHP requirement.

Solution: As in the example above, no temperature information is given so 70°F is assumed.

The 1.5" static pressure given is at an elevation of 5,000 ft. The first step is to convert this static pressure to equivalent sea level conditions.

$$\text{Sea level static pressure} = 1.5 / .832 = 1.80"$$

Enter the blower table at 6000 sCFM and static pressure of 1.8". The rpm listed will be the same rpm needed at 5,000 ft.

Suppose that the corresponding BHP listed in the table is 3.2. This value must be corrected for elevation.

$$\text{BHP at 5,000 ft} = 3.2 \times .832 = 2.66$$

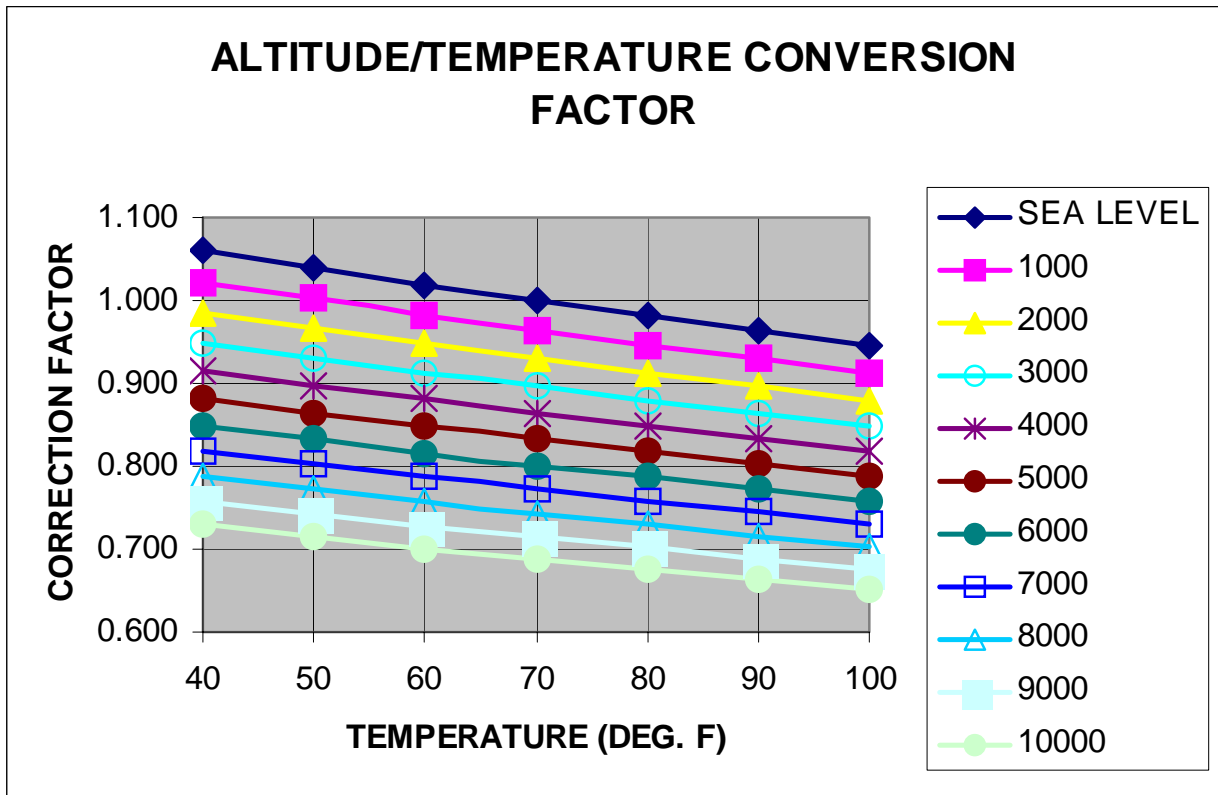

FIGURE 21 - ALTITUDE/TEMPERATURE CONVERSION FACTOR

TABLE 33: FAN PERFORMANCE - 25 TON^{1, 2}

AIRFLOW CFM	AVAILABLE EXTERNAL STATIC PRESSURE (IWG)									
	0.2		0.4		0.6		0.8		1.0	
	RPM	BHP ³	RPM	BHP ³	RPM	BHP ³	RPM	BHP ³	RPM	BHP ³
4000	-	-	342	0.59	404	0.82	456	1.08	506	1.35
5000	306	0.62	362	0.83	415	1.08	465	1.36	512	1.66
6000	337	0.93	387	1.17	433	1.43	478	1.72	521	2.04
7000	370	1.34	415	1.60	456	1.88	497	2.20	535	2.54
8000	408	1.88	446	2.17	484	2.49	520	2.80	555	3.15
9000	444	2.56	480	2.86	514	3.21	547	3.58	579	3.96
10000	481	3.40	514	3.76	545	4.11	576	4.47	606	4.83
11000	520	4.38	550	4.74	579	5.12	608	5.54	635	5.97
12000	557	5.55	585	5.96	612	6.37	638	6.78	664	7.19
13000	596	6.90	622	7.32	647	7.76	671	8.22	696	8.69

AIRFLOW CFM	AVAILABLE EXTERNAL STATIC PRESSURE (IWG)									
	1.2		1.4		1.6		1.8		2.0	
	RPM	BHP ³	RPM	BHP ³	RPM	BHP ³	RPM	BHP ³	RPM	BHP ³
4000	549	1.63	591	1.93	628	2.23	663	2.55	698	2.86
5000	555	1.97	597	2.31	634	2.66	670	3.00	705	3.38
6000	562	2.39	602	2.74	638	3.11	674	3.52	709	3.92
7000	573	2.88	610	3.27	645	3.68	679	4.09	713	4.50
8000	591	3.55	624	3.95	657	4.35	689	4.76	720	5.19
9000	611	4.34	642	4.72	673	5.12	703	5.59	732	6.06
10000	634	5.23	663	5.68	692	6.13	719	6.58	747	7.03
11000	662	6.39	689	6.82	715	7.25	741	7.70	766	8.21
12000	690	7.62	714	8.10	739	8.59	763	9.07	787	9.55
13000	720	9.15	743	9.61	766	10.09	789	10.65	811	11.20

AIRFLOW CFM	AVAILABLE EXTERNAL STATIC PRESSURE (IWG)									
	2.2		2.4		2.6		2.8		3.0	
	RPM	BHP ³	RPM	BHP ³	RPM	BHP ³	RPM	BHP ³	RPM	BHP ³
4000	728	3.19	757	3.53	787	3.87	814	4.21	839	4.55
5000	736	3.75	767	4.13	798	4.50	825	4.88	851	5.28
6000	740	4.32	772	4.73	803	5.14	830	5.58	858	6.03
7000	744	4.92	775	5.37	805	5.84	833	6.31	861	6.78
8000	751	5.67	781	6.15	810	6.63	837	7.11	865	7.60
9000	760	6.53	789	7.00	817	7.48	843	8.01	870	8.55
10000	774	7.48	801	8.01	826	8.54	852	9.07	878	9.60
11000	792	8.72	817	9.24	841	9.75	865	10.30	890	10.90
12000	811	10.05	834	10.63	857	11.21	880	11.79	903	12.38
13000	833	11.76	855	12.32	877	12.87	899	13.43	921	13.99

AIRFLOW CFM	AVAILABLE EXTERNAL STATIC PRESSURE (IWG)									
	3.2		3.4		3.6		3.8		4.0	
	RPM	BHP ³	RPM	BHP ³	RPM	BHP ³	RPM	BHP ³	RPM	BHP ³
4000	864	4.90	890	5.26	913	5.64	935	6.01	957	6.39
5000	878	5.69	904	6.10	927	6.51	950	6.92	973	7.33
6000	885	6.47	911	6.91	935	7.36	959	7.82	983	8.29
7000	889	7.25	914	7.74	939	8.24	964	8.75	988	9.25
8000	892	8.13	918	8.66	942	9.18	967	9.71	992	10.26
9000	897	9.09	921	9.63	946	10.18	970	10.78	995	11.37
10000	903	10.15	927	10.76	951	11.36	975	11.97	999	12.57
11000	913	11.50	936	12.10	959	12.70	983	13.30	1005	13.90
12000	926	12.96	948	13.54	970	14.12	992	14.70	1013	15.33
13000	942	14.55	963	15.12	984	15.79	1005	16.45	1025	17.11

1. Fan performance is based on wet evaporator coils, clean 2" throwaway filters and system/cabinet effects at standard air density and 0' elevation.
2. Refer to Tables 6, 11, 17 and 36 for component additions and deductions to fan performance tables.
3. BHP does not include drive losses. Multiply BHP by 1.05 to account for drive losses.

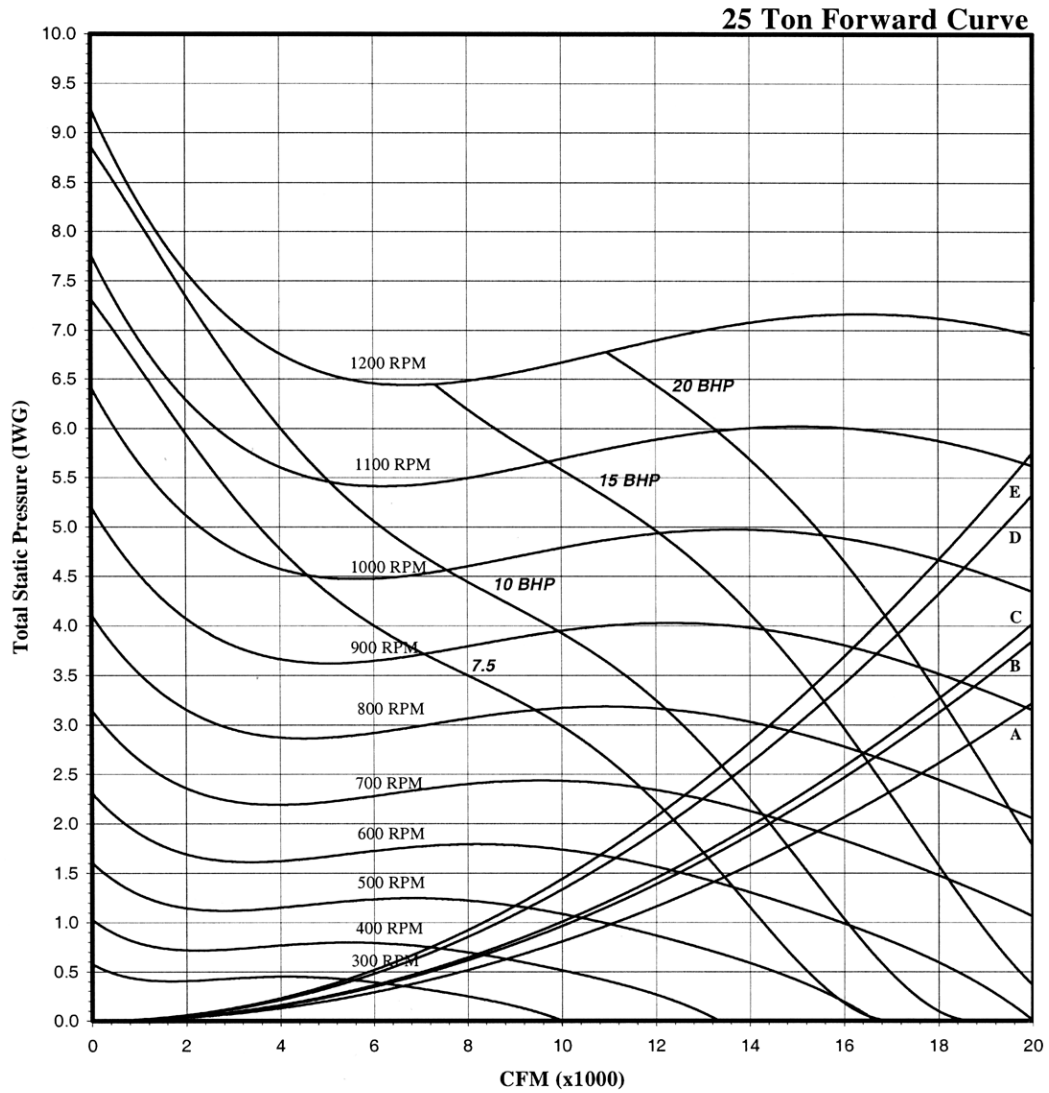

- A - Standard Unit
 - B - Standard Unit + Economizer
 - C - Standard Unit + Economizer + Low Heat
 - D - Standard Unit + Economizer + High Heat
 - E - Standard Unit + Economizer + High Heat + Power Exhaust
- Note: Standard Unit includes wet evaporator coil, clean 2" throwaway filters, system and cabinet effects at standard air density and 0' elevation.

FIGURE 22 - FAN PERFORMANCE - 25 TON

TABLE 34: FAN PERFORMANCE - 30 TON ^{1, 2}

AIRFLOW (CFM)	AVAILABLE EXTERNAL STATIC PRESSURE (IWG)									
	0.2		0.4		0.6		0.8		1.0	
	RPM	BHP ³	RPM	BHP ³	RPM	BHP ³	RPM	BHP ³	RPM	BHP ³
6000	321	0.9	373	1.1	422	1.5	469	1.8	513	2.1
7000	357	1.3	404	1.6	447	1.9	490	2.2	529	2.6
8000	398	1.8	437	2.1	477	2.5	515	2.9	551	3.3
9000	436	2.5	473	2.8	509	3.2	543	3.6	577	4.0
10000	477	3.2	511	3.7	543	4.1	575	4.5	606	5.0
11000	519	4.2	549	4.7	579	5.1	609	5.6	637	6.1
12000	560	5.4	589	5.9	617	6.4	643	6.9	670	7.4
13000	603	6.8	629	7.3	654	7.8	680	8.4	705	8.9
14000	645	8.4	669	8.9	694	9.5	718	10.0	741	10.7
15000	688	10.2	711	10.8	733	11.5	755.6	12.1	778	12.7

AIRFLOW (CFM)	AVAILABLE EXTERNAL STATIC PRESSURE (IWG)									
	1.2		1.4		1.6		1.8		2.0	
	RPM	BHP ³	RPM	BHP ³	RPM	BHP ³	RPM	BHP ³	RPM	BHP ³
6000	554	2.4	596	2.8	632	3.2	668	3.5	703	3.9
7000	568	3.0	607	3.4	642	3.8	676	4.2	710	4.6
8000	587	3.7	622	4.1	655	4.5	689	5.0	720	5.4
9000	610	4.5	642	4.9	673	5.4	704	5.9	734	6.4
10000	636	5.5	666	6.0	695	6.5	723	7.0	751	7.5
11000	665	6.6	693	7.1	720	7.6	746	8.2	773	8.8
12000	697	7.9	722	8.5	747	9.1	772	9.6	797	10.2
13000	729	9.5	753	10.0	777	10.7	801	11.3	824	11.9
14000	764	11.3	787	11.9	809	12.6	831	13.2	853	13.8
15000	800	13.3	821	13.9	842	14.6	863	15.2	884	15.9

AIRFLOW (CFM)	AVAILABLE EXTERNAL STATIC PRESSURE (IWG)									
	2.2		2.4		2.6		2.8		3.0	
	RPM	BHP ³	RPM	BHP ³	RPM	BHP ³	RPM	BHP ³	RPM	BHP ³
6000	734	4.3	765	4.7	796	5.1	824	5.5	850	6.0
7000	741	5.0	772	5.5	803	6.0	830	6.4	858	6.9
8000	750	5.9	781	6.4	810	6.9	837	7.4	865	7.9
9000	763	6.9	792	7.4	820	7.9	847	8.5	873	9.0
10000	779	8.0	807	8.6	833	9.1	859	9.7	885	10.3
11000	799	9.3	824	9.9	849	10.5	874	11.1	899	11.7
12000	821	10.8	845	11.5	869	12.1	893	12.7	916	13.4
13000	847	12.6	869	13.2	892	13.9	914	14.5	936	15.1
14000	874	14.5	896	15.1	917	15.8	938	16.5	959	17.2
15000	904	16.6	924	17.4	944	18.1	964	18.8	984	19.5

AIRFLOW (CFM)	AVAILABLE EXTERNAL STATIC PRESSURE (IWG)									
	3.2		3.4		3.6		3.8		4.0	
	RPM	BHP ³	RPM	BHP ³	RPM	BHP ³	RPM	BHP ³	RPM	BHP ³
6000	877	6.4	904	6.8	928	7.3	951	7.7	975	8.2
7000	885	7.3	911	7.8	935	8.3	959	8.8	984	9.2
8000	892	8.4	917	8.9	942	9.4	966	9.9	991	10.4
9000	900	9.5	925	10.1	949	10.6	974	11.2	998	11.8
10000	910	10.9	934	11.5	958	12.1	982	12.7	1006	13.3
11000	923	12.4	946	13.0	970	13.6	993	14.2	1015	14.8
12000	939	14.0	961	14.6	984	15.3	1006	16.0	1028	16.7
13000	958	15.8	980	16.5	1001	17.2	1022	17.9	1043	18.6
14000	980	17.9	1001	18.7	1021	19.4	1040	20.1	1060	20.8
15000	1004	20.2	1023	21.0	1043	21.8	1062	22.5	1081	23.3

1. Fan performance is based on wet evaporator coils, clean 2" throwaway filters and system/cabinet effects at standard air density and 0' elevation.
2. Refer to Tables 6, 11, 17 and 36 for component additions and deductions to fan performance tables.
3. BHP does not include drive losses. Multiply BHP by 1.05 to account for drive losses.

30 Ton Forward Curve

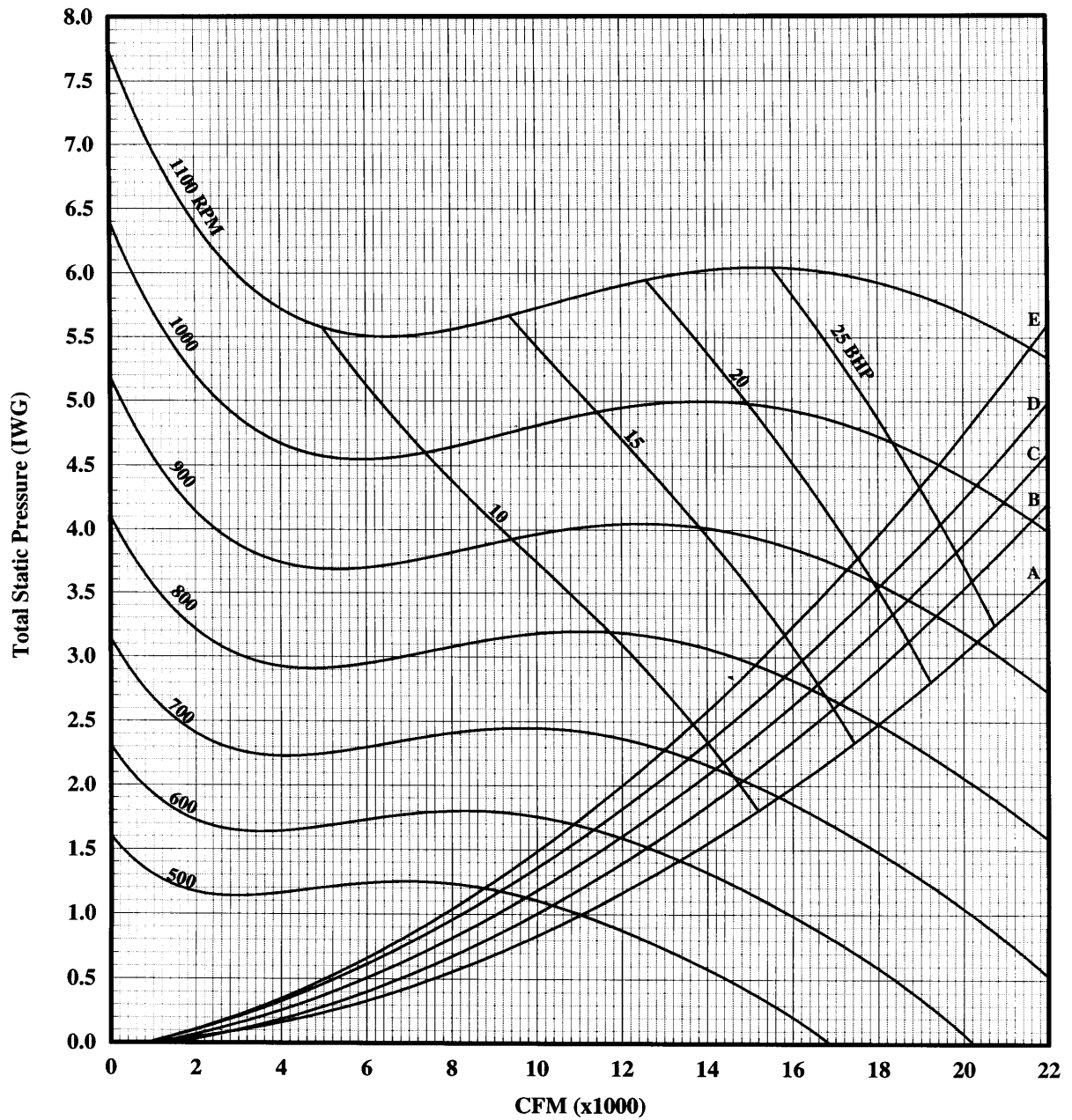

- A - Standard Unit
 - B - Standard Unit + Economizer
 - C - Standard Unit + Economizer + Low Heat
 - D - Standard Unit + Economizer + High Heat
 - E - Standard Unit + Economizer + High Heat + Power Exhaust
- Note: Standard Unit includes wet evaporator coil, clean 2" throwaway filters, system and cabinet effects at standard air density and 0' elevation.

FIGURE 23 - FAN PERFORMANCE - 30 TON

TABLE 35: FAN PERFORMANCE - 40 TON^{1,2}

AIRFLOW (CFM)	AVAILABLE EXTERNAL STATIC PRESSURE (IWG)									
	0.2		0.4		0.6		0.8		1.0	
	RPM	BHP ³	RPM	BHP ³	RPM	BHP ³	RPM	BHP ³	RPM	BHP ³
8000	304	1.3	348	1.7	393	2.1	431	2.5	469	2.9
9000	329	1.8	371	2.2	411	2.6	448	3.0	484	3.5
10000	356	2.3	396	2.7	432	3.2	467	3.7	502	4.2
11000	385	2.9	421	3.4	454	3.9	488	4.5	519	5.0
12000	414	3.7	446	4.3	479	4.8	510	5.4	539	5.9
13000	442	4.6	473	5.2	504	5.8	532	6.4	560	7.0
14000	472	5.7	502	6.3	529	6.9	556	7.6	583	8.2
15000	503	6.9	529	7.6	555	8.2	581	8.9	607	9.6
16000	532	8.3	557	9.0	583	9.7	607	10.4	631	11.2
17000	562	9.9	587	10.6	611	11.4	633	12.1	656	12.9
18000	593	11.7	616	12.5	638	13.2	660	14.0	682	14.7

AIRFLOW (CFM)	AVAILABLE EXTERNAL STATIC PRESSURE (IWG)									
	1.2		1.4		1.6		1.8		2.0	
	RPM	BHP ³	RPM	BHP ³	RPM	BHP ³	RPM	BHP ³	RPM	BHP ³
8000	506	3.3	537	3.8	569	4.2	601	4.7	627	5.2
9000	518	4.0	549	4.4	581	4.9	610	5.5	637	6.0
10000	532	4.7	563	5.2	594	5.8	621	6.3	648	6.8
11000	549	5.5	579	6.1	608	6.7	634	7.2	661	7.8
12000	568	6.5	596	7.1	623	7.7	649	8.3	675	9.0
13000	588	7.6	614	8.2	640	8.9	665	9.5	690	10.2
14000	609	8.9	634	9.5	658	10.2	683	10.9	707	11.6
15000	631	10.3	655	11.0	679	11.7	702	12.5	724	13.2
16000	654	11.9	677	12.6	700	13.4	722	14.1	743	14.9
17000	678	13.6	701	14.4	722	15.2	742	16.0	763	16.8
18000	703	15.6	724	16.4	744	17.2	764	18.1	785	18.9

AIRFLOW (CFM)	AVAILABLE EXTERNAL STATIC PRESSURE (IWG)									
	2.2		2.4		2.6		2.8		3.0	
	RPM	BHP ³	RPM	BHP ³	RPM	BHP ³	RPM	BHP ³	RPM	BHP ³
8000	654	5.7	681	6.2	706	6.7	729	7.2	752	7.7
9000	664	6.5	691	7.0	715	7.6	738	8.1	761	8.7
10000	675	7.4	701	8.0	725	8.6	748	9.1	771	9.7
11000	687	8.4	712	9.0	735	9.7	758	10.3	781	10.9
12000	700	9.6	723	10.2	747	10.9	770	11.6	793	12.3
13000	714	10.9	737	11.6	760	12.3	782	13.0	805	13.7
14000	729	12.4	752	13.1	774	13.8	796	14.5	817	15.2
15000	746	13.9	768	14.7	790	15.4	811	16.2	831	17.0
16000	764	15.7	786	16.5	807	17.3	826	18.1	846	18.9
17000	784	17.6	805	18.5	824	19.3	843	20.1	863	21.0
18000	805	19.7	824	20.6	843	21.5	862	22.4	881	23.3

AIRFLOW (CFM)	AVAILABLE EXTERNAL STATIC PRESSURE (IWG)									
	3.2		3.4		3.6		3.8		4.0	
	RPM	BHP ³	RPM	BHP ³	RPM	BHP ³	RPM	BHP ³	RPM	BHP ³
8000	774	8.3	797	8.8	817	9.4	837	9.9	857	10.5
9000	784	9.3	806	9.8	826	10.4	846	11.0	866	11.6
10000	794	10.3	815	11.0	836	11.6	856	12.3	876	12.9
11000	804	11.6	824	12.2	845	12.9	865	13.6	886	14.2
12000	814	12.9	835	13.6	855	14.3	876	15.0	896	15.7
13000	825	14.4	846	15.1	866	15.8	886	16.6	906	17.3
14000	837	16.0	858	16.8	878	17.5	898	18.3	917	19.1
15000	851	17.8	871	18.6	891	19.4	910	20.2	928	21.0
16000	866	19.7	886	20.5	905	21.4	923	22.2	941	23.1
17000	882	21.9	901	22.7	919	23.6	937	24.5	-	-
18000	900	24.2	-	-	-	-	-	-	-	-

1. Fan performance is based on wet evaporator coils, clean 2" throwaway filters and system/cabinet effects at standard air density and 0° elevation.
2. Refer to Tables 8, 14, 19 and 36 for component additions and deductions to fan performance tables.
3. BHP does not include drive losses. Multiply BHP by 1.05 to account for drive losses.

40 Ton Forward Curve

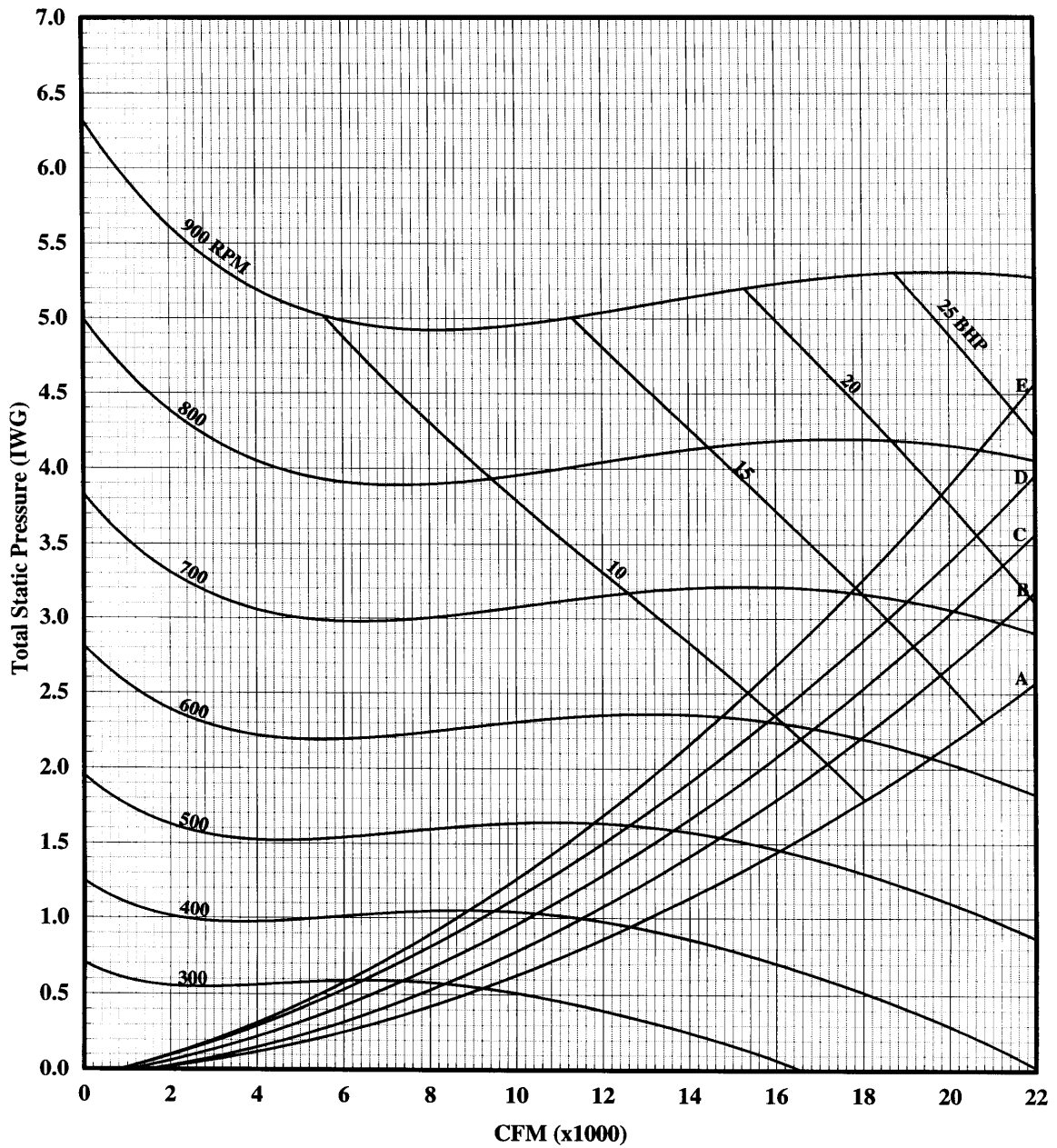

- A - Standard Unit
 - B - Standard Unit + Economizer
 - C - Standard Unit + Economizer + Low Heat
 - D - Standard Unit + Economizer + High Heat
 - E - Standard Unit + Economizer + High Heat + Power Exhaust
- Note: Standard Unit includes wet evaporator coil, clean 2" throwaway filters, system and cabinet effects at standard air density and 0' elevation.

FIGURE 24 - FAN PERFORMANCE - 40 TON

TABLE 36: COMPONENT STATIC RESISTANCE^{1, 2}

COMPONENT COIL LOSSES	CFM						
	6,000	8,000	10,000	12,000	14,000	16,000	18,000
STD. 25 TON, DRY	-0.06	-0.08	-0.10	-0.13	-	-	-
STD. 25 TON, WET	Baseline	Baseline	Baseline	Baseline	Baseline	Baseline	Baseline
STD. 30 TON, DRY	-0.045	-0.075	-0.112	-0.157	-0.207	-0.264	-0.326
STD. 30 TON, WET	Baseline	Baseline	Baseline	Baseline	Baseline	Baseline	Baseline
HI CAP 30 TON, DRY	-0.019	-0.035	-0.052	-0.073	-0.098	-0.124	-0.155
HI CAP 30 TON, WET	0.042	0.069	0.103	0.142	0.186	0.236	0.290
STD. 40 TON, DRY	-0.030	-0.051	-0.076	-0.106	-0.140	-0.177	-0.219
STD. 40 TON, WET	Baseline	Baseline	Baseline	Baseline	Baseline	Baseline	Baseline
HI CAP 40 TON, DRY	-0.020	-0.033	-0.050	-0.069	-0.092	-0.116	-0.144
HI CAP 40 TON, WET	0.023	0.038	0.057	0.079	0.105	0.133	0.164
FILTER LOSSES							
2" TA OR HI EFF.	Baseline	Baseline	Baseline	Baseline	Baseline	Baseline	Baseline
RIGID 6", 65%	0.048	0.080	0.119	0.165	0.217	0.274	0.338
RIGID 6", 95%	0.189	0.308	0.448	0.609	0.790	0.988	1.205
IGV LOSSES							
25 & 30 TON	0.048	0.085	0.132	0.190	0.259	0.338	0.428
40 TON	0.027	0.049	0.076	0.110	0.149	0.195	0.246
GAS HEAT							
233 MBH HEAT	0.106	0.141	0.177	0.212	0.247	0.283	0.318
466 MBH HEAT	0.212	0.283	0.353	0.424	0.495	0.566	0.636
699 MBH HEAT	0.318	0.423	0.531	0.636	0.741	0.849	0.954
ELECTRIC HEAT	0.050	0.100	0.150	0.310	0.430	0.530	0.680
ECONOMIZER	0.063	0.104	0.153	0.210	0.276	0.349	0.429
POWER EXHAUST	0.046	0.081	0.127	0.182	0.248	0.324	0.410

1. Baseline losses based on system/cabinet effects, wet standard coil and 2" throwaway filters at 70°F, 0° elevation with standard air.

2. See Tables 6, 8, 11, 14 and 17 for hot water and steam water coil static resistance.

TABLE 37: POWER EXHAUST - ONE FORWARD CURVED FAN 25 TON¹

AIRFLOW CFM	AVAILABLE EXTERNAL STATIC PRESSURE (IWG)									
	0.2		0.4		0.6		0.8		1.0	
	RPM	BHP ²	RPM	BHP ²	RPM	BHP ²	RPM	BHP ²	RPM	BHP ²
2000	---	---	---	---	524	0.32	609	0.42	685	0.54
3000	---	---	450	0.41	531	0.51	605	0.64	672	0.77
4000	442	0.63	496	0.74	562	0.87	626	1.00	687	1.16
5000	524	1.15	566	1.29	609	1.43	663	1.58	717	1.74
6000	612	1.84	646	2.08	679	2.25	717	2.43	762	2.60
7000	703	2.86	731	3.16	759	3.37	787	3.57	820	3.78
8000	791	3.63	821	4.09	844	4.54	868	4.99	892	5.23
9000	877	5.53	911	5.88	932	6.22	953	6.57	974	6.92
10000	967	8.02	1004	8.34	1022	8.66	1041	8.98	1059	9.30

AIRFLOW CFM	AVAILABLE EXTERNAL STATIC PRESSURE (IWG)									
	1.2		1.4		1.6		1.8		2.0	
	RPM	BHP ²	RPM	BHP ²	RPM	BHP ²	RPM	BHP ²	RPM	BHP ²
2000	754	0.66	819	0.78	878	0.90	933	1.03	986	1.16
3000	736	0.92	797	1.08	854	1.24	909	1.41	961	1.58
4000	743	1.32	799	1.47	850	1.66	900	1.84	948	2.04
5000	768	1.90	818	2.08	865	2.28	911	2.48	955	2.68
6000	806	2.78	850	2.95	895	3.17	937	3.40	978	3.62
7000	857	3.98	895	4.19	933	4.39	972	4.60	1010	4.80
8000	921	5.47	953	5.71	985	5.95	1018	6.19	1052	6.43
9000	995	7.27	1020	7.59	1048	7.86	1075	8.13	1103	8.39
10000	1077	9.62	1096	9.94	1119	10.25	1143	10.55	1167	10.86

1. Fan performance is based on system/cabinet effects and back draft damper effects at standard air density and 0° elevation.
2. BHP does not include drive losses. Multiply BHP by 1.05 to account for drive losses.

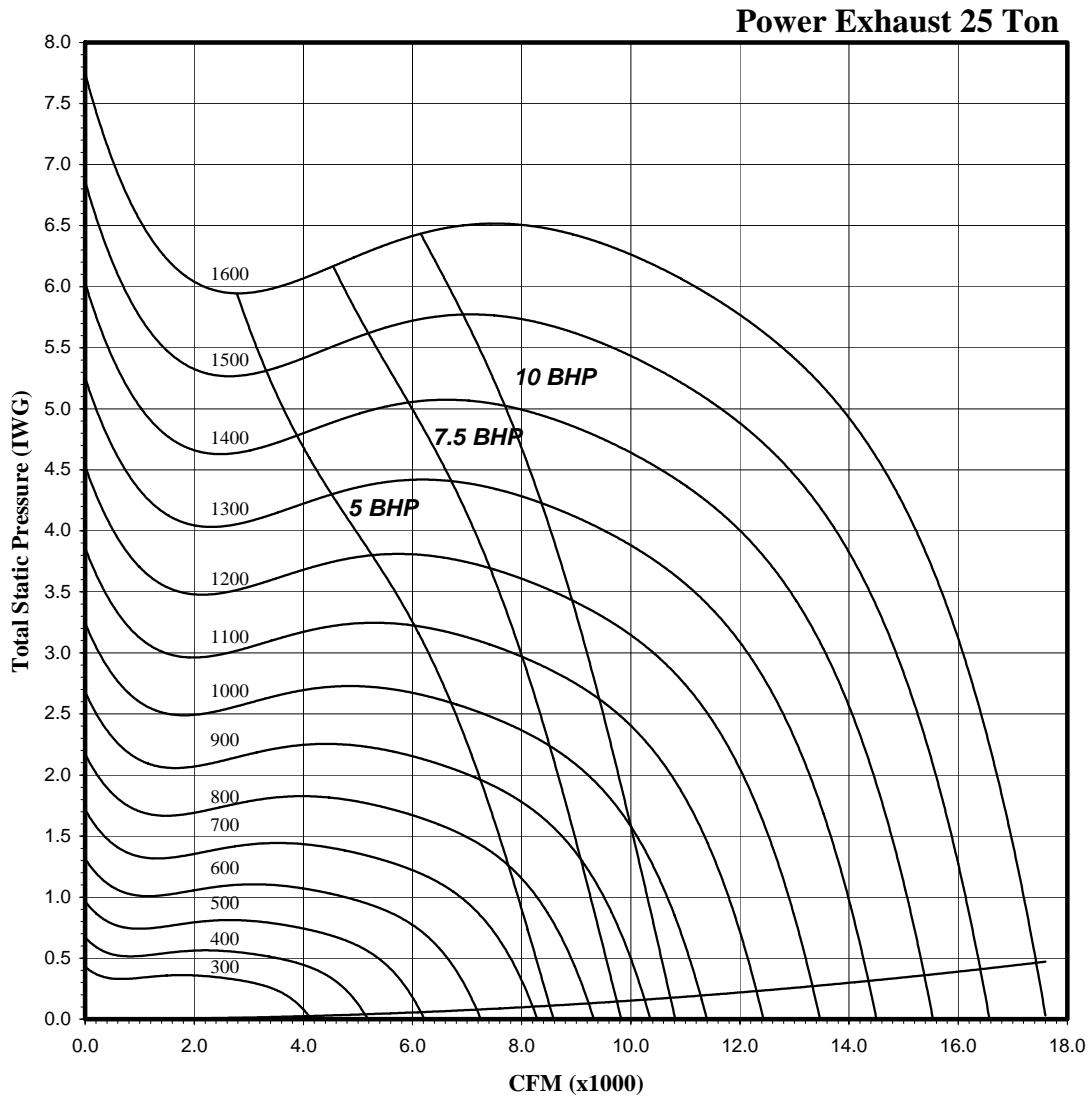

FIGURE 25 - POWER EXHAUST - ONE FORWARD CURVE FAN - 25 TONS

TABLE 38: POWER EXHAUST - TWO FORWARD CURVED FANS - 30 & 40 TON¹

AIRFLOW CFM	AVAILABLE EXTERNAL STATIC PRESSURE (IWG)									
	0.2		0.4		.06		0.8		1.0	
	RPM	BHP ^{2 3}	RPM	BHP ^{2 3}	RPM	BHP ^{2 3}	RPM	BHP ^{2 3}	RPM	BHP ^{2 3}
4000	363	0.3	468	0.5	560	0.7	641	0.9	716	1.1
5000	402	0.5	494	0.7	576	1.0	652	1.2	722	1.4
6000	445	0.8	527	1.0	602	1.3	670	1.6	735	1.9
7000	494	1.2	565	1.5	633	1.7	697	2.0	757	2.4
8000	544	1.7	609	2.0	670	2.3	729	2.6	784	3.0
9000	597	2.3	654	2.7	711	3.0	765	3.3	817	3.7
10000	651	3.1	703	3.5	754	3.8	805	4.2	853	4.6
11000	705	4.1	753	4.5	801	4.9	847	5.3	893	5.7
12000	761	5.2	805	5.6	849	6.0	893	6.5	934	6.9
13000	817	6.6	858	7.0	899	7.4	939	7.9	979	8.4
14000	874	8.1	912	8.6	950	9.1	988	9.5	1025	10.0
15000	932	9.9	967	10.4	1002	11.0	1037	11.5	1072	12.0
16000	989	12.0	1022	12.6	1055	13.1	1088	13.6		

AIRFLOW CFM	AVAILABLE EXTERNAL STATIC PRESSURE (IWG)									
	1.2		1.4		1.6		1.8		2	
	RPM	BHP ^{2 3}	RPM	BHP ^{2 3}	RPM	BHP ^{2 3}	RPM	BHP ^{2 3}	RPM	BHP ^{2 3}
4000	783	1.4	844	1.6	903	1.8	956	2.1	1008	2.3
5000	788	1.7	848	2.0	906	2.3	959	2.5	1011	2.8
6000	798	2.1	855	2.5	911	2.8	963	3.1	1014	3.4
7000	814	2.7	869	3.0	922	3.3	972	3.7	1021	4.0
8000	837	3.3	889	3.7	938	4.0	987	4.4	1033	4.8
9000	866	4.1	915	4.5	961	4.9	1007	5.3	1050	5.7
10000	900	5.0	945	5.4	989	5.9	1032	6.3	1073	6.8
11000	936	6.1	979	6.6	1020	7.0	1061	7.5	1101	7.9
12000	976	7.4	1016	7.9	1055	8.3	1094	8.8	1131	9.3
13000	1018	8.9	1055	9.4	1093	9.9	1129	10.4	1165	11.0
14000	1061	10.6	1098	11.1	1133	11.7	1167	12.3	1202	12.8
15000	1107	12.6	1141	13.1	1175	13.7	1208	14.2	1240	14.8

1. Fan performance is based on system/cabinet effects and back draft damper effects at standard air density and 0° elevation.
2. BHP includes the sum of both exhaust fan blowers
3. BHP does not include drive losses. Multiply BHP by 1.05 to account for drive losses.

Power Exhaust

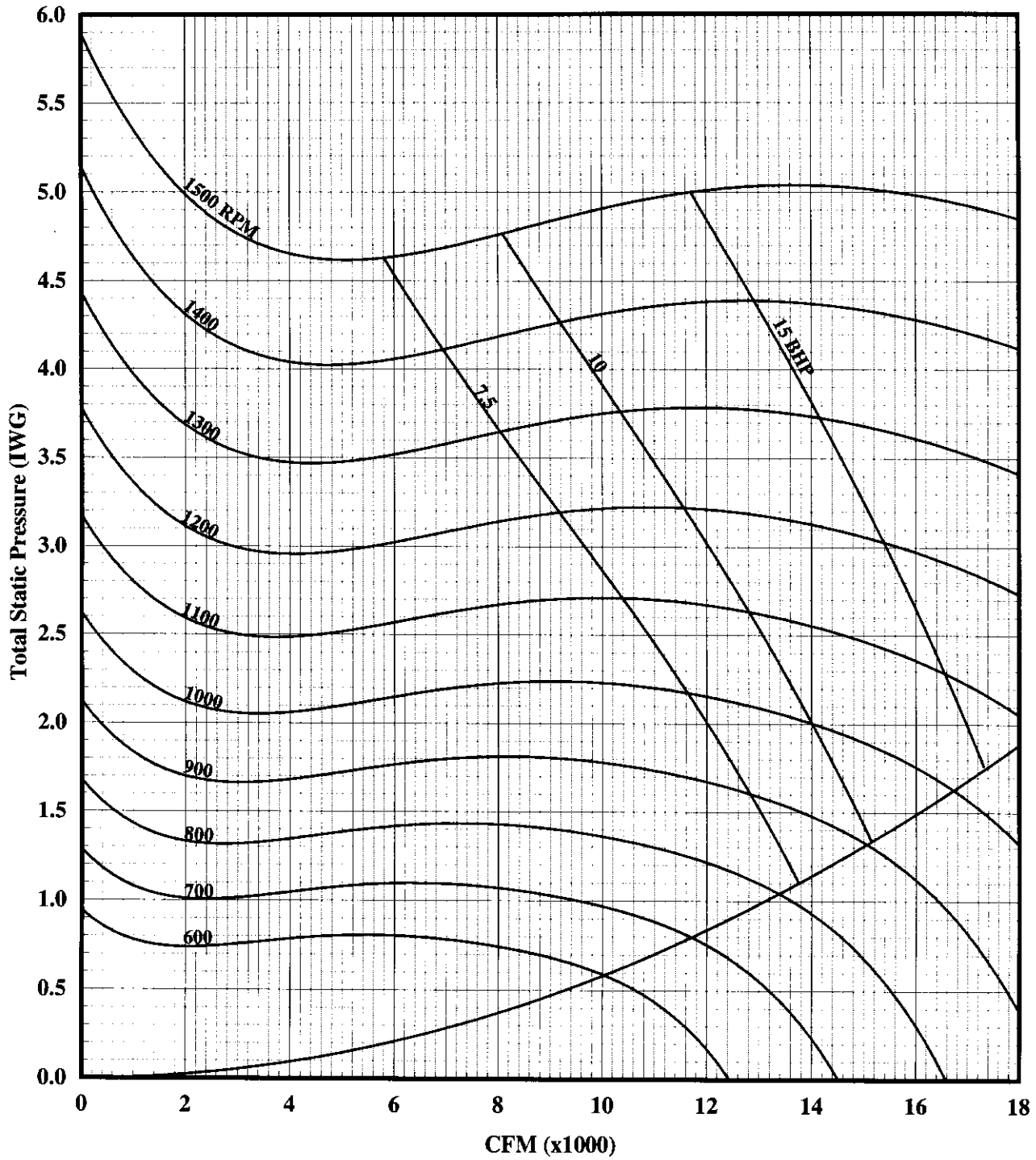

FIGURE 26 - POWER EXHAUST - TWO FORWARD CURVED FANS - 30 & 40 TONS

TABLE 39: ELECTRICAL DATA 25 TON BASIC UNIT

VOLTAGE	COMPRESSORS			COND. FAN MOTOR		SUPPLY AIR MOTOR		BASIC UNIT	
	QTY.	RLA	LRA	QTY.	FLA	HP	FLA	MCA	MAX OVERCURRENT PROTECTION DEVICE
208-3-60	2	45.7	350	4	7.6 ea.	7.5	24.2	157	200
						10	30.8	164	200
						15	46.2	180	225
						20	59.4	196	250
230-3-60	2	45.7	350	4	6.9 ea.	7.5	22.0	152	175
						10	28.0	158	200
						15	42.0	172	200
						20	54.0	187	225
460-3-60	2	24.3	158	4	3.5 ea.	7.5	11.0	80	100
						10	14.0	83	100
						15	21.0	90	110
						20	27.0	96	110
575-3-60	2	19.3	125	4	3.0 ea.	7.5	9.0	64	80
						10	11.0	66	80
						15	17.0	72	90
						20	22.0	78	100

TABLE 40: ELECTRICAL DATA 30 TON BASIC UNIT

VOLTAGE	COMPRESSORS			COND. FAN MOTOR			SUPPLY AIR MOTOR		BASIC UNIT	
	QTY.	RLA	LRA	QTY.	FLA	TOTAL	HP	FLA	MCA	MAX. Overcurrent Protection Device
208-3-60	3	38.5	228	3	4.0 ea.	12.0	10	30.8	168	200
							15	46.2	185	225
							20	59.4	202	250
							25	74.8	221	250
230-3-60	3	38.5	255	3	3.6 ea.	10.8	10	28	164	200
							15	42	179	200
							20	54	194	225
							25	68	211	250
460-3-60	3	18.8	127	3	2.2 ea.	6.6	10	14	81	90
							15	21	88	100
							20	27	96	110
							25	34	104	125
575-3-60	3	15.7	100	3	1.4 ea.	4.2	10	11	66	80
							15	17	73	80
							20	22	79	100
							25	27	85	110

TABLE 41: ELECTRICAL DATA 40 TON BASIC UNIT

VOLTAGE	COMPRESSORS			COND. FAN MOTOR			SUPPLY AIR MOTOR		BASIC UNIT	
	QTY.	RLA	LRA	QTY.	FLA	TOTAL	HP	FLA	MCA	MAX. Overcurrent Protection Device
208-3-60	4	38.5	228	4	4.0 ea.	12.0	10	30.8	210	225
							15	46.2	228	250
							20	59.4	244	300
							25	74.8	264	300
230-3-60	4	38.5	255	4	3.6 ea.	14.4	10	28	206	225
							15	42	221	250
							20	54	236	250
							25	68	253	300
460-3-60	4	18.8	127	4	2.2 ea.	8.8	10	14	101	110
							15	21	109	125
							20	27	116	125
							25	34	125	150
575-3-60	4	15.7	100	4	1.4 ea.	5.6	10	11	83	90
							15	17	90	100
							20	22	96	110
							25	27	102	125

TABLE 42: ELECTRICAL DATA 25 TON BASIC UNIT W/ ELECTRIC HEAT

VOLTAGE	ELECTRIC HEAT		SUPPLY AIR MOTOR		BASIC UNIT W/ ELECTRIC HEAT	
	NOMINAL KW	APPLIED KW	HP	FLA	MCA	MAX OVERCURRENT PROTECTION DEVICE
208-3-60	40	30	7.5	24.2	157	200
			10	30.8	164	200
			15	46.2	180	225
			20	59.4	196	250
	80	60.1	7.5	22.0	197	225
			10	28.0	205	225
			15	42.0	225	250
			20	54.0	241	300
230-3-60	40	40	7.5	11.0	152	175
			10	14.0	158	200
			15	21.0	172	200
			20	27.0	187	225
	80	80	7.5	9.0	212	250
			10	11.0	219	250
			15	17.0	237	250
			20	22.0	252	300
460-3-60	40	40	7.5	24.2	80	100
			10	30.8	83	100
			15	46.2	90	110
			20	59.4	96	110
	80	80	7.5	22.0	106	125
			10	28.0	110	125
			15	42.0	118	125
			20	54.0	126	150
	108	108	7.5	22.0	138	150
			10	28.0	142	175
			15	42.0	151	175
			20	54.0	158	175
575-3-60	40	40	7.5	11.0	64	80
			10	14.0	66	80
			15	21.0	72	90
			20	27.0	78	100
	80	80	7.5	9.0	92	110
			10	11.0	94	110
			15	17.0	102	110
			20	22.0	108	125
	108	108	7.5	9.0	120	150
			10	11.0	122	150
			15	17.0	130	150
			20	22.0	136	150

TABLE 43: ELECTRICAL DATA 30 TON BASIC UNIT W/ ELECTRIC HEAT

VOLTAGE	ELECTRIC HEAT		SUPPLY AIR MOTOR		BASIC UNIT WITH ELECTRIC HEAT	
	NOMINAL kW	APPLIED kW	HP	FLA	MCA	MAX OVERCURRENT PROTECTION DEVICE
208-3-60	40	30	10	30.8	210	225
			15	46.2	228	250
			20	59.4	244	300
			25	74.8	264	300
	80	60.1	10	30.8	210	225
			15	46.2	228	250
			20	59.4	244	300
			25	74.8	264	300
230-3-60	40	40	10	28	206	225
			15	42	221	250
			20	54	236	250
			25	68	253	300
	80	80	10	28	227	250
			15	42	245	250
			20	54	260	300
			25	68	277	300
460-3-60	40	40	10	14	101	110
			15	21	109	125
			20	27	116	125
			25	34	125	150
	80	80	10	14	114	125
			15	21	122	125
			20	27	130	150
			25	34	139	150
	108	108	10	14	147	175
			15	21	156	175
			20	27	164	175
			25	34	172	200
575-3-60	40	40	10	11	83	90
			15	17	90	100
			20	22	96	110
			25	27	102	125
	80	80	10	11	94	110
			15	17	102	110
			20	22	108	125
			25	27	114	125
	108	108	10	11	122	150
			15	17	130	150
			20	22	136	150
			25	27	142	150

TABLE 44: ELECTRICAL DATA 40 TON BASIC UNIT W/ ELECTRIC HEAT

VOLTAGE	ELECTRIC HEAT		SUPPLY AIR MOTOR		BASIC UNIT WITH ELECTRIC HEAT	
	NOMINAL KW	APPLIED KW	HP	FLA	MCA	MAX. OVERCURRENT PROTECTION DEVICE
208-3-60	40	30	10	30.8	210	225
			15	46.2	228	250
			20	59.4	244	300
			25	74.8	264	300
	80	60.1	10	30.8	210	225
			15	46.2	228	250
			20	59.4	244	300
			25	74.8	264	300
230-3-60	40	40	10	28.0	206	225
			15	42.0	221	250
			20	54.0	236	250
			25	68.0	253	300
	80	80	10	28.0	227	250
			15	42.0	245	250
			20	54.0	260	300
			25	68.0	277	300
460-3-60	40	40	10	14.0	101	110
			15	21.0	109	125
			20	27.0	116	125
			25	34.0	125	150
	80	80	10	14.0	114	125
			15	21.0	122	125
			20	27.0	130	150
			25	34.0	139	150
	108	108	10	14.0	147	175
			15	21.0	156	175
			20	27.0	164	175
			25	34.0	172	200
575-3-60	40	40	10	11.0	83	90
			15	17.0	90	100
			20	22.0	96	110
			25	27.0	102	125
	80	80	10	11.0	94	110
			15	17.0	102	110
			20	22.0	108	125
			25	27.0	114	125
	108	108	10	11.0	122	150
			15	17.0	130	150
			20	22.0	136	150
			25	27.0	142	150

TABLE 45: ELECTRICAL DATA 25 TON BASIC UNIT W/ POWER EXHAUST

VOLTAGE	SUPPLY AIR MOTOR	EXHAUST FAN MOTOR		BASIC UNIT W/ EXHAUST FAN	
	HP	HP	FLA	MCA	MAX OVERCURRENT PROTECTION DEVICE
208-3-60	7.5	5	16.7	174	200
		7.5	24.2	182	225
		10	30.8	188	225
	10	5	16.7	181	225
		7.5	24.2	188	225
		10	30.8	195	225
	15	5	16.7	196	225
		7.5	24.2	204	225
		10	30.8	210	250
	20	5	16.7	213	250
		7.5	24.2	220	250
		10	30.8	227	250
230-3-60	7.5	5	15.2	168	200
		7.5	22.0	174	200
		10	28.0	180	225
	10	5	15.2	174	200
		7.5	22.0	180	225
		10	28.0	186	225
	15	5	15.2	188	225
		7.5	22.0	194	225
		10	28.0	200	225
	20	5	15.2	202	250
		7.5	22.0	209	250
		10	28.0	215	250
460-3-60	7.5	5	7.6	87	110
		7.5	11.0	91	110
		10	14.0	94	110
	10	5	7.6	90	110
		7.5	11.0	94	110
		10	14.0	97	110
	15	5	7.6	97	110
		7.5	11.0	101	110
		10	14.0	104	125
	20	5	7.6	104	125
		7.5	11.0	107	125
		10	14.0	110	125
575-3-60	7.5	5	6.1	71	80
		7.5	9.0	74	90
		10	11.0	76	90
	10	5	6.1	73	90
		7.5	9.0	76	90
		10	11.0	78	90
	15	5	6.1	79	90
		7.5	9.0	82	100
		10	11.0	84	100
	20	5	6.1	84	100
		7.5	9.0	87	100
		10	11.0	89	110

TABLE 46: ELECTRICAL DATA 30 TON BASIC UNIT W/ POWER EXHAUST

VOLTAGE	SUPPLY AIR MOTOR	EXHAUST FAN MOTOR		BASIC UNIT WITH EXHAUST FAN	
	HP	HP	FLA	MCA	MAX. OVERCURRENT PROTECTION DEVICE
208-3-60	10	7.5	24.2	192	225
		10	30.8	199	225
		15	46.2	216	250
	15	7.5	24.2	209	250
		10	30.8	216	250
		15	46.2	231	250
	20	7.5	24.2	226	250
		10	30.8	233	250
		15	46.2	248	300
	25	7.5	24.2	245	300
		10	30.8	252	300
		15	46.2	267	300
230-3-60	10	7.5	22.0	186	200
		10	28.0	192	225
		15	42.0	207	225
	15	7.5	22.0	201	225
		10	28.0	207	225
		15	42.0	221	250
	20	7.5	22.0	216	250
		10	28.0	222	250
		15	42.0	236	250
	25	7.5	22.0	233	300
		10	28.0	239	300
		15	42.0	253	300
460-3-60	10	7.5	11.0	92	110
		10	14.0	95	110
		15	21.0	102	110
	15	7.5	11.0	99	110
		10	14.0	102	110
		15	21.0	109	125
	20	7.5	11.0	107	125
		10	14.0	110	125
		15	21.0	117	125
	25	7.5	11.0	115	125
		10	14.0	118	150
		15	21.0	125	150
575-3-60	10	7.5	9.0	75	90
		10	11.0	77	90
		15	17.0	84	100
	15	7.5	9.0	82	90
		10	11.0	84	100
		15	17.0	90	100
	20	7.5	9.0	88	100
		10	11.0	90	110
		15	17.0	96	110
	25	7.5	9.0	94	110
		10	11.0	96	110
		15	17.0	102	125

TABLE 47: ELECTRICAL DATA 40 TON BASIC UNIT W/ POWER EXHAUST

VOLTAGE	SUPPLY AIR MOTOR	EXHAUST FAN MOTOR		BASIC UNIT WITH EXHAUST FAN	
	HP	HP	FLA	MCA	MAX. OVERCURRENT PROTECTION DEVICE
208-3-60	10	7.5	24.2	235	250
		10	30.8	241	250
		15	46.2	259	300
	15	7.5	24.2	252	300
		10	30.8	259	300
		15	46.2	274	300
	20	7.5	24.2	268	300
		10	30.8	275	300
		15	46.2	290	300
	25	7.5	24.2	288	350
		10	30.8	294	350
		15	46.2	310	350
230-3-60	10	7.5	22	228	250
		10	28	234	250
		15	42	249	250
	15	7.5	22	243	250
		10	28	249	250
		15	42	263	300
	20	7.5	22	258	300
		10	28	264	300
		15	42	278	300
	25	7.5	22	275	300
		10	28	281	300
		15	42	295	350
460-3-60	10	7.5	11	112	125
		10	14	115	125
		15	21	123	125
	15	7.5	11	120	125
		10	14	123	125
		15	21	130	150
	20	7.5	11	127	150
		10	14	130	150
		15	21	137	150
	25	7.5	11	136	150
		10	14	139	150
		15	21	146	175
575-3-60	10	7.5	9	92	100
		10	11	94	110
		15	17	101	110
	15	7.5	9	99	110
		10	11	101	110
		15	17	107	110
	20	7.5	9	105	125
		10	11	107	125
		15	17	113	125
	25	7.5	9	111	125
		10	11	113	125
		15	17	119	125

TABLE 48: ELECTRICAL DATA 25 TON BASIC UNIT W/ POWER EXHAUST & ELEC HEAT

VOLTAGE	ELECTRIC HEAT		SUPPLY AIR MOTOR	EXHAUST FAN MOTOR		BASIC UNIT W/ EXHAUST FAN		
	NOMINAL KW	APPLIED KW	HP	HP	FLA	MCA	MAX OVERCURRENT PROTECTION DEVICE	
208-3-60	40	30	7.5	5	16.7	174	200	
				7.5	24.2	182	225	
				10	30.8	188	225	
			10	30	5	16.7	181	225
					7.5	24.2	188	225
					10	30.8	195	225
			15	30	5	16.7	196	225
					7.5	24.2	204	225
					10	30.8	210	250
			20	30	5	16.7	213	250
					7.5	24.2	220	250
					10	30.8	227	250
	80	60.1	7.5	5	16.7	218	225	
				7.5	24.2	227	250	
				10	30.8	236	250	
			10	60.1	5	16.7	226	250
					7.5	24.2	236	250
					10	30.8	244	250
			15	60.1	5	16.7	245	250
					7.5	24.2	255	300
					10	30.8	263	300
			20	60.1	5	16.7	262	300
					7.5	24.2	271	300
					10	30.8	280	300
230-3-60	40	40	7.5	5	15.2	168	200	
				7.5	22.0	174	200	
				10	28.0	180	225	
			10	40	5	15.2	174	200
					7.5	22.0	180	225
					10	28.0	186	225
			15	40	5	15.2	188	225
					7.5	22.0	195	225
					10	28.0	203	225
			20	40	5	15.2	202	250
					7.5	22.0	210	250
					10	28.0	218	250
	80	80	7.5	5	15.2	231	250	
				7.5	22.0	239	250	
				10	28.0	247	250	
			10	80	5	15.2	238	250
					7.5	22.0	247	250
					10	28.0	254	300
			15	80	5	15.2	256	300
					7.5	22.0	264	300
					10	28.0	272	300
			20	80	5	15.2	271	300
					7.5	22.0	279	300
					10	28.0	287	300

TABLE 48: ELECTRICAL DATA 25 TON BASIC UNIT W/ POWER EXHAUST & ELEC HEAT (CONTINUED)

VOLTAGE	ELECTRIC HEAT		SUPPLY AIR MOTOR	EXHAUST FAN MOTOR		BASIC UNIT W/ EXHAUST FAN	
	NOMINAL KW	APPLIED KW	HP	HP	FLA	MCA	MAX OVERCURRENT PROTECTION DEVICE
460-3-60	40	30	7.5	5	7.6	87	110
				7.5	11.0	91	110
				10	14.0	94	110
			10	5	7.6	90	110
				7.5	11.0	94	110
				10	14.0	97	110
			15	5	7.6	97	110
				7.5	11.0	101	110
				10	14.0	104	125
			20	5	7.6	104	125
				7.5	11.0	107	125
				10	14.0	110	125
	80	80	7.5	5	7.6	115	125
				7.5	11.0	120	125
				10	14.0	123	125
			10	5	7.6	119	125
				7.5	11.0	123	125
				10	14.0	127	150
			15	5	7.6	128	150
				7.5	11.0	132	150
				10	14.0	136	150
			20	5	7.6	135	150
				7.5	11.0	140	150
				10	14.0	143	150
	108	108	7.5	5	7.6	148	175
				7.5	11.0	152	175
				10	14.0	156	175
			10	5	7.6	151	175
				7.5	11.0	156	175
				10	14.0	159	175
			15	5	7.6	160	175
				7.5	11.0	164	175
				10	14.0	168	175
			20	5	7.6	168	175
				7.5	11.0	172	175
				10	14.0	176	200

TABLE 48: ELECTRICAL DATA 25 TON BASIC UNIT W/ POWER EXHAUST & ELEC HEAT (CONTINUED)

VOLTAGE	ELECTRIC HEAT		SUPPLY AIR MOTOR	EXHAUST FAN MOTOR			BASIC UNIT W/ EXHAUST FAN	
	NOMINAL KW	APPLIED KW	HP	HP	FLA	MCA	MAX OVERCURRENT PROTECTION DEVICE	
575-3-60	40	40	7.5	5	6.1	71	80	
				7.5	9.0	74	90	
				10	11.0	76	90	
			10	5	6.1	73	90	
				7.5	9.0	76	90	
				10	11.0	78	90	
			15	5	6.1	79	90	
				7.5	9.0	83	100	
				10	11.0	85	100	
			20	5	6.1	85	100	
				7.5	9.0	89	100	
				10	11.0	91	110	
	80	80	7.5	5	6.1	99	110	
				7.5	9.0	103	110	
				10	11.0	105	110	
			10	5	6.1	102	110	
				7.5	9.0	105	110	
				10	11.0	108	110	
			15	5	6.1	109	110	
				7.5	9.0	113	125	
				10	11.0	115	125	
			20	5	6.1	115	125	
				7.5	9.0	119	125	
				10	11.0	122	125	
	108	108	7.5	5	6.1	127	150	
				7.5	9.0	131	150	
				10	11.0	133	150	
			10	5	6.1	130	150	
				7.5	9.0	133	150	
				10	11.0	136	150	
			15	5	6.1	137	150	
				7.5	9.0	141	150	
				10	11.0	143	150	
			20	5	6.1	144	150	
				7.5	9.0	147	150	
				10	11.0	150	175	

TABLE 49: ELECTRICAL DATA 30 TON BASIC UNIT W/ POWER EXHAUST & ELEC HEAT

VOLTAGE	ELECTRIC HEAT		SUPPLY AIR Motor	EXHAUST FAN		BASIC UNIT WITH EXHAUST FAN AND ELECTRIC HEAT	
	NOMINAL KW	APPLIED KW	HP	HP	FLA	MCA	MAX. OVERCURRENT PROTECTION DEVICE
208-3-60	40	30	10	7.5	24.2	192	225
				10	30.8	199	225
				15	46.2	216	250
			15	7.5	24.2	209	250
				10	30.8	216	250
				15	46.2	231	250
			20	7.5	24.2	226	250
				10	30.8	233	250
				15	46.2	248	300
			25	7.5	24.2	245	300
				10	30.8	252	300
				15	46.2	267	300
	80	60.1	10	7.5	24.2	236	250
				10	30.8	244	250
				15	46.2	263	300
			15	7.5	24.2	255	300
				10	30.8	263	300
				15	46.2	282	300
			20	7.5	24.2	271	300
				10	30.8	280	300
				15	46.2	299	300
			25	7.5	24.2	291	350
				10	30.8	299	350
				15	46.2	318	350
230-3-60	40	40	10	7.5	22	186	200
				10	28	192	225
				15	42	208	225
			15	7.5	22	201	225
				10	28	208	225
				15	42	225	250
			20	7.5	22	216	250
				10	28	223	250
				15	42	240	250
			25	7.5	22	233	300
				10	28	240	300
				15	42	258	300
	80	80	10	7.5	22	255	300
				10	28	262	300
				15	42	280	300
			15	7.5	22	272	300
				10	28	280	300
				15	42	297	300
			20	7.5	22	287	300
				10	28	295	300
				15	42	312	350
			25	7.5	22	305	350
				10	28	312	350
				15	42	330	350

TABLE 49: ELECTRICAL DATA 30 TON BASIC UNIT W/ POWER EXHAUST & ELEC HEAT (CONTINUED)

VOLTAGE	ELECTRIC HEAT		SUPPLY AIR Motor	EXHAUST FAN		BASIC UNIT WITH EXHAUST FAN AND ELECTRIC HEAT	
	NOMINAL KW	APPLIED KW	HP	HP	FLA	MCA	MAX. OVERCURRENT PROTECTION DEVICE
460-3-60	40	40	10	7.5	11	92	110
				10	14	95	110
				15	21	104	110
			15	7.5	11	100	110
				10	14	104	110
				15	21	113	125
			20	7.5	11	108	125
				10	14	111	125
				15	21	120	125
			25	7.5	11	116	125
				10	14	120	150
				15	21	129	150
	80	80	10	7.5	11	127	150
				10	14	131	150
				15	21	140	150
			15	7.5	11	136	150
				10	14	140	150
				15	21	149	150
			20	7.5	11	144	150
				10	14	147	150
				15	21	156	175
			25	7.5	11	152	175
				10	14	156	175
				15	21	165	175
	108	108	10	7.5	11	161	175
				10	14	165	175
				15	21	174	175
			15	7.5	11	170	175
				10	14	174	175
				15	21	182	200
20			7.5	11	177	200	
			10	14	181	200	
			15	21	190	200	
25			7.5	11	186	200	
			10	14	190	200	
			15	21	199	225	

TABLE 49: ELECTRICAL DATA 30 TON BASIC UNIT W/ POWER EXHAUST & ELEC HEAT (CONTINUED)

VOLTAGE	ELECTRIC HEAT		SUPPLY AIR Motor	EXHAUST FAN		BASIC UNIT WITH EXHAUST FAN AND ELECTRIC HEAT			
	NOMINAL KW	APPLIED KW	HP	HP	FLA	MCA	MAX. OVERCURRENT PROTECTION DEVICE		
575-3-60	40	40	10	7.5	9	75	90		
				10	11	78	90		
				15	17	85	100		
			15	7.5	9	83	90		
				10	11	85	100		
				15	17	93	100		
			20	7.5	9	89	100		
				10	11	91	110		
				15	17	99	110		
			25	7.5	9	95	110		
				10	11	98	110		
				15	17	105	125		
	80	80	10	7.5	9	105	110		
				10	11	108	110		
				15	17	115	125		
			15	7.5	9	113	125		
				10	11	115	125		
				15	17	123	125		
			20	7.5	9	119	125		
				10	11	122	125		
				15	17	129	150		
			25	7.5	9	125	150		
				10	11	128	150		
				15	17	135	150		
			108	108	10	7.5	9	133	150
						10	11	136	150
						15	17	143	150
15	7.5	9			141	150			
	10	11			143	150			
	15	17			151	175			
20	7.5	9			147	150			
	10	11			150	150			
	15	17			157	175			
25	7.5	9			153	175			
	10	11			156	175			
	15	17			163	175			

TABLE 50: ELECTRICAL DATA 40 TON BASIC UNIT W/ POWER EXHAUST & ELEC HEAT

VOLTAGE	ELECTRIC HEAT		SUPPLY AIR MOTOR	EXHAUST FAN			BASIC UNIT WITH EXHAUST FAN AND ELECTRIC HEAT	
	NOMINAL KW	APPLIED KW	HP	HP	FLA	MCA	MAX. OVERCURRENT PROTECTION DEVICE	
208-3-60	40	30	10	7.5	24.2	235	250	
				10	30.8	241	250	
				15	46.2	259	300	
			15	7.5	24.2	252	300	
				10	30.8	259	300	
				15	46.2	274	300	
			20	7.5	24.2	268	300	
				10	30.8	275	300	
				15	46.2	290	300	
			25	7.5	24.2	288	350	
				10	30.8	294	350	
				15	46.2	310	350	
	80	60.1	10	7.5	24.2	236	250	
				10	30.8	244	250	
				15	46.2	263	300	
			15	7.5	24.2	255	300	
				10	30.8	263	300	
				15	46.2	282	300	
			20	7.5	24.2	271	300	
				10	30.8	280	300	
				15	46.2	299	350	
			25	7.5	24.0	291	350	
				10	30.8	299	350	
				15	46.2	318	350	
230-3-60	40	40	10	7.5	22	228	250	
				10	28	234	250	
				15	42	249	250	
			15	7.5	22	243	250	
				10	28	249	250	
				15	42	263	300	
			20	7.5	22	258	300	
				10	28	267	300	
				15	42	278	300	
			25	7.5	22	275	300	
				10	28	281	300	
				15	42	295	350	
	80	80	10	7.5	22	255	300	
				10	28	262	300	
				15	42	280	300	
			15	7.5	22	272	300	
				10	28	280	300	
				15	42	297	300	
			20	7.5	22	287	300	
				10	28	295	300	
				15	42	312	350	
			25	7.5	22	305	350	
				10	28	312	350	
				15	42	330	350	

TABLE 50: ELECTRICAL DATA 40 TON BASIC UNIT W/ POWER EXHAUST & ELEC HEAT (CONTINUED)

VOLTAGE	ELECTRIC HEAT		SUPPLY AIR MOTOR	EXHAUST FAN		BASIC UNIT WITH EXHAUST FAN AND ELECTRIC HEAT	
	NOMINAL KW	APPLIED KW	HP	HP	FLA	MCA	MAX. OVERCURRENT PROTECTION DEVICE
460-3-60	40	40	10	7.5	11	112	125
				10	14	115	125
				15	21	123	125
			15	7.5	11	120	125
				10	14	123	125
				15	21	130	150
			20	7.5	11	127	150
				10	14	130	150
				15	21	137	150
			25	7.5	11	136	150
				10	14	139	150
				15	21	146	175
	80	80	10	7.5	11	127	150
				10	14	131	150
				15	21	140	150
			15	7.5	11	136	150
				10	14	140	150
				15	21	149	150
			20	7.5	11	144	150
				10	14	147	150
				15	21	156	175
			25	7.5	11	152	175
				10	14	156	175
				15	21	165	175
	108	108	10	7.5	11	161	175
				10	14	165	175
				15	21	174	175
			15	7.5	11	170	175
				10	14	174	175
				15	21	182	200
			20	7.5	11	177	200
				10	14	181	200
				15	21	190	200
			25	7.5	11	186	200
				10	14	190	200
				15	21	199	225

TABLE 50: ELECTRICAL DATA 40 TON BASIC UNIT W/ POWER EXHAUST & ELEC HEAT (CONTINUED)

VOLTAGE	ELECTRIC HEAT		SUPPLY AIR MOTOR	EXHAUST FAN		BASIC UNIT WITH EXHAUST FAN AND ELECTRIC HEAT	
	NOMINAL KW	APPLIED KW	HP	HP	FLA	MCA	MAX. OVERCURRENT PROTECTION DEVICE
575-3-60	40	40	10	7.5	9	92	100
				10	11	94	110
				15	17	101	110
			15	7.5	9	99	110
				10	11	101	110
				15	17	107	110
			20	7.5	9	105	125
				10	11	107	125
				15	17	113	125
			25	7.5	9	111	125
				10	11	113	125
				15	17	119	125
	80	80	10	7.5	9	105	110
				10	11	108	110
				15	17	115	125
			15	7.5	9	113	125
				10	11	115	125
				15	17	123	125
			20	7.5	9	119	125
				10	11	122	125
				15	17	129	150
			25	7.5	9	125	150
				10	11	128	150
				15	17	135	150
	108	108	10	7.5	9	133	150
				10	11	136	150
				15	17	143	150
			15	7.5	9	141	150
				10	11	143	150
				15	17	151	175
			20	7.5	9	147	150
				10	11	150	150
				15	17	157	175
			25	7.5	9	153	175
				10	11	156	175
				15	17	163	175

TABLE 51: UNIT WEIGHTS

COMPONENT	25 TON	30 TON	40 TON
BASIC UNIT¹	4,300	4,600	5,100
GAS HEAT			
233 MBH	90	90	90
466 MBH	180	180	180
699 MBH	--	--	270
ELECTRIC HEAT			
40KW	75	75	75
80KW	90	90	90
108KW	100	100	100
HOT WATER HEAT			
HOT WATER COIL 1 ROW	71	71 lbs.	71 lbs
HOT WATER COIL 2 ROW	90	90 lbs.	90 lbs.
STEAM HEAT			
STEAM COIL 1 ROW	87 lbs.	87 lbs.	87 lbs.
BLOWER MOTOR (STD./HI-EFF)			
7.5HP	0/10	-	-
10HP	10/20	0/10	0/10
15HP	60/100	50/90	50/90
20HP	105/110	95/100	85/110
25HP	-	165/200	165/200
VARIABLE FREQUENCY DRIVE			
WITHOUT BYPASS			
7.5HP	12	12	12
10HP	13	13	13
15HP	13	13	13
20 & 25HP	24	24	24
WITH MANUAL BYPASS			
7.5HP	102	102	102
10HP	102	102	102
15HP	153	153	153
20 & 25HP	234	234	234
INLET GUIDE VANES W/ ACTUATOR	175	175	205
EXHAUST			
BAROMETRIC	40	75	75
POWERED	180	325	325
EXHAUST MOTOR (STD./HI-EFF)			
5HP	75/90	-	-
7.5HP	100/110	100/110	100/110
10HP	110/120	110/120	110/120
15HP	-	160/200	160/200
LOW AMBIENT HEAD PRESSURE CONTROL			
208/203V,460V & 380-3-50Hz	10	10	10
575V & 380-3-60 Hz	40	40	40
FILTERS			
6" RIGID	80	80	80
REFRIGERATION			
HI CAPACITY COIL	0	45	25
COATED COND. COIL	32	30	40
HOT GAS BYPASS	20	20	20
DISCONNECT			
CONVENIENCE OUTLET	40/40	40/40	40/40
ACCESSORIES			
PARTIAL CURB	385	385	385
FULL CURB	545	545	545

¹. Weight includes the 10HP motor and economizer.

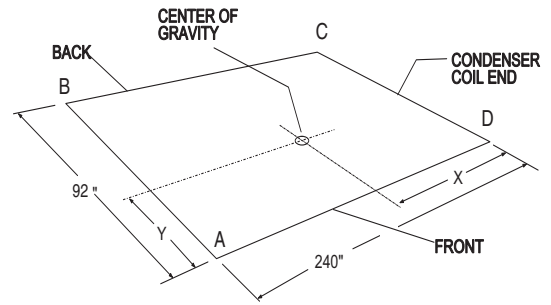

FIGURE 27 - CENTER OF GRAVITY

TABLE 52: UNIT CENTER OF GRAVITY

MODEL	25 TON		30 TON		40 TON	
	X	Y	X	Y	X	Y
BASIC UNIT	99"	46"	98"	45"	93"	46"
BASIC UNIT /W ECON.	110"	46"	108"	45"	97"	46"
BASIC UNIT /W ECON. & GAS OR ELECT. HEAT, STEAM OR HOT WATER HEAT	104"	45"	102"	44"	96"	45"
BASIC UNIT /W ECON. & GAS OR ELECT. HEAT, & POWER EXHAUST	118"	45"	112"	44"	108"	45"

TABLE 53: UNIT CORNERWEIGHT

UNIT DESCRIPTION	25 TON				30 TON				40 TON			
	A	B	C	D	A	B	C	D	A	B	C	D
BASIC UNIT	988	988	1162	1162	1011	987	1189	1213	1088	1088	1363	1363
BASIC UNIT WITH ECONOMIZER	1058	1058	1192	1192	1106	1080	1194	1220	1153	1153	1398	1398
BASIC UNIT WITH ECONOMIZER AND GAS OR ELECTRIC HEAT	1107	1107	1232	1232	1131	1080	1259	1310	1203	1173	1437	1467
BASIC UNIT WITH ECONOMIZER AND GAS OR ELECTRIC HEAT AND POWER EXHAUST	1261	1261	1272	1272	1262	1206	1290	1346	1347	1317	1457	1487

TABLE 54: INDOOR SOUND POWER RATING

MODEL NUMBER	CFM	ESP	BLOWER		SOUND POWER (dB 10-12 WATTS)								
					OCTAVE BAND CENTERLINE FREQUENCY (Hz)								dba
					IWG	RPM	BHP	63	125	250	500	1000	
Y22	10,000	1.5	750	7.5	90	88	85	85	80	78	74	68	87
Y23	12750	1.5	840	12.8	93	91	88	88	83	81	77	71	90
Y24	17500	1.3	800	20	95	92	89	89	84	83	78	72	91

Sound Power Ratings for Supply Air Blowers in our Millenium Units with High Gas Heat, Economizer, 2: T/A Filters and Wet DX Sound power calculations complements of Lau's revised "Whirlwind" application selection software for air moving components.

The sound ratings above occur at the blower wheel. To determine the sound rating at a unit's supply and return air duct connection, subtract the attenuation factors listed below.

TABLE 55: ATTENUATION FACTORS

LOCATION	OCTAVE BAND CENTERLINE FREQUENCY (Hz)							
	63	125	250	500	1000	2000	4000	8000
	SOUND ATTENUATION (dB ¹² WATTS)							
SUPPLY AIR	11	13	18	10	21	21	23	23
RETURN AIR	13	15	22	23	25	25	29	29

TABLE 56: OUTDOOR SOUND POWER RATING

MODEL	Octave Band Centerline Frequency (Hertz)								db(A)
	65	125	250	500	1000	2000	4000	8000	
	Sound Power Level, db (10)-12 Watts								
Y22	83	88	82	80	77	73	71	69	88
Y23	82	87	81	79	77	74	72	70	87
Y24	83	88	82	80	78	75	73	71	88

NOTE: These values have been accessed using a model of sound propagation from a point source into the hemispheric free field (AMCA 303-79). The dBA values provided are to be used for reference only. Calculation of dBA values cover matters of system design, and the fan manufacturer has no way of

knowing the details of each system. This constitutes an exception to any specification or guarantee requiring a dBA value or sound data in any other form than sound power level ratings.

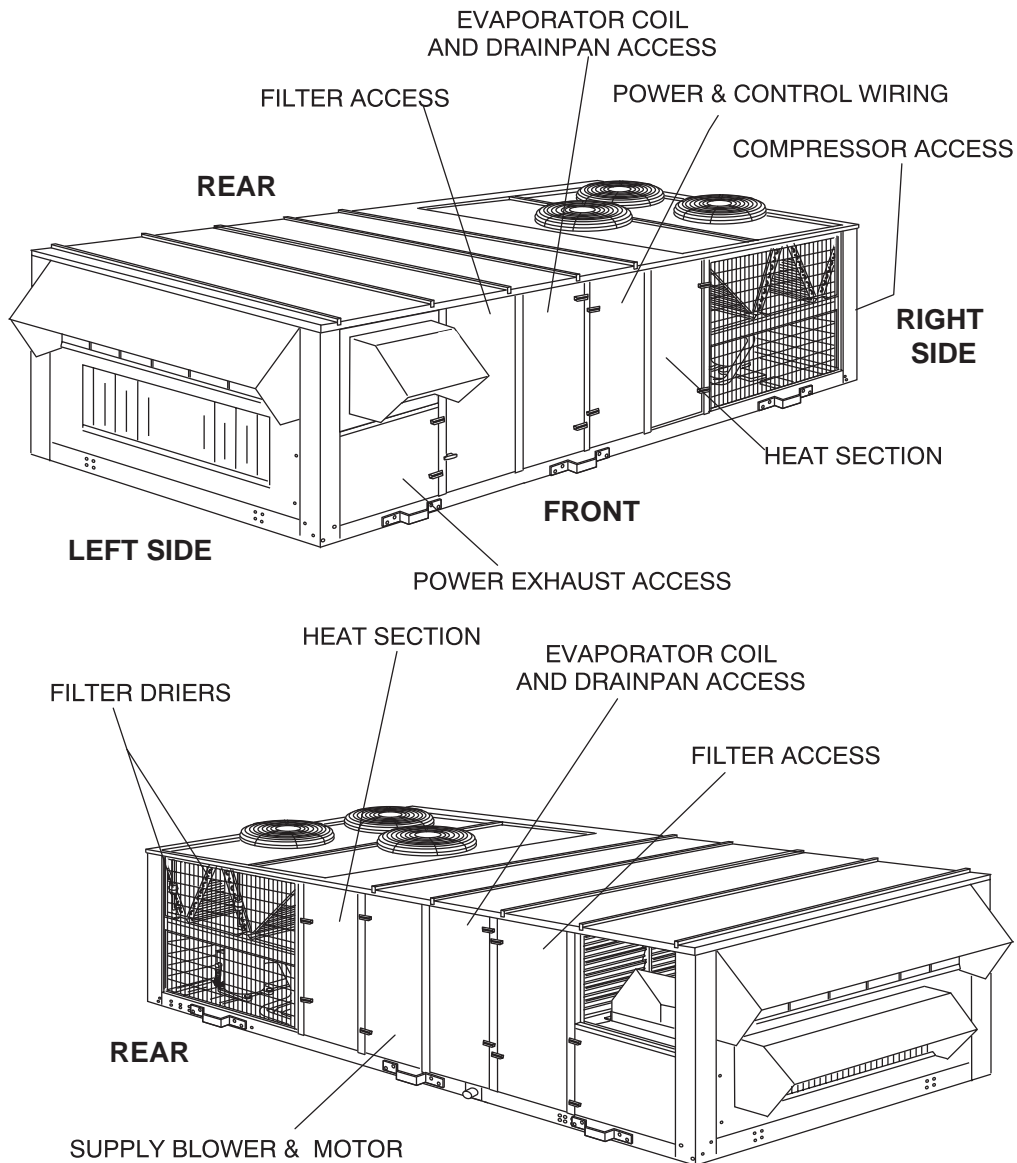

FIGURE 28 - COMPONENT LOCATION

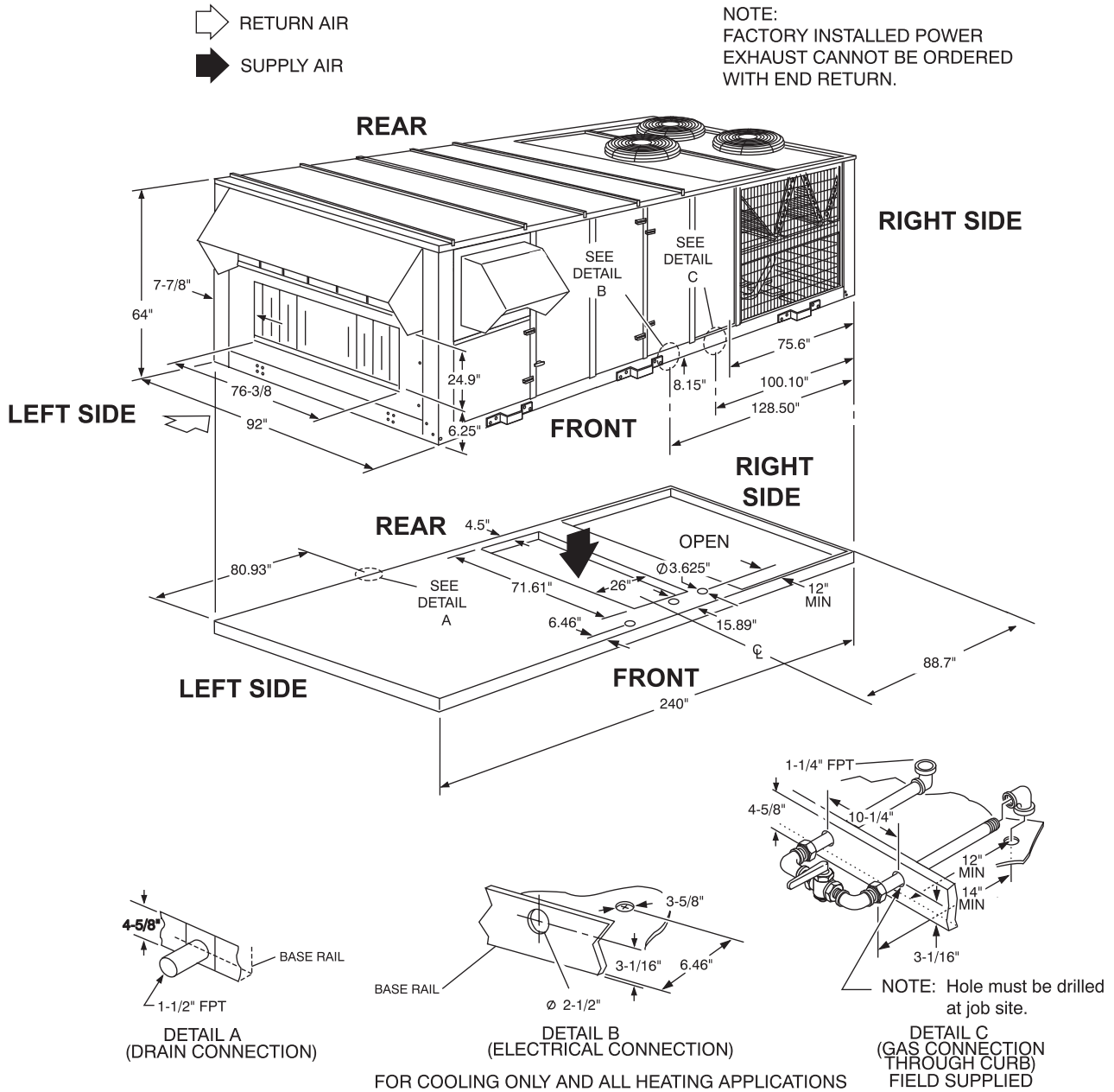

FIGURE 29 - END RETURN, BOTTOM SUPPLY

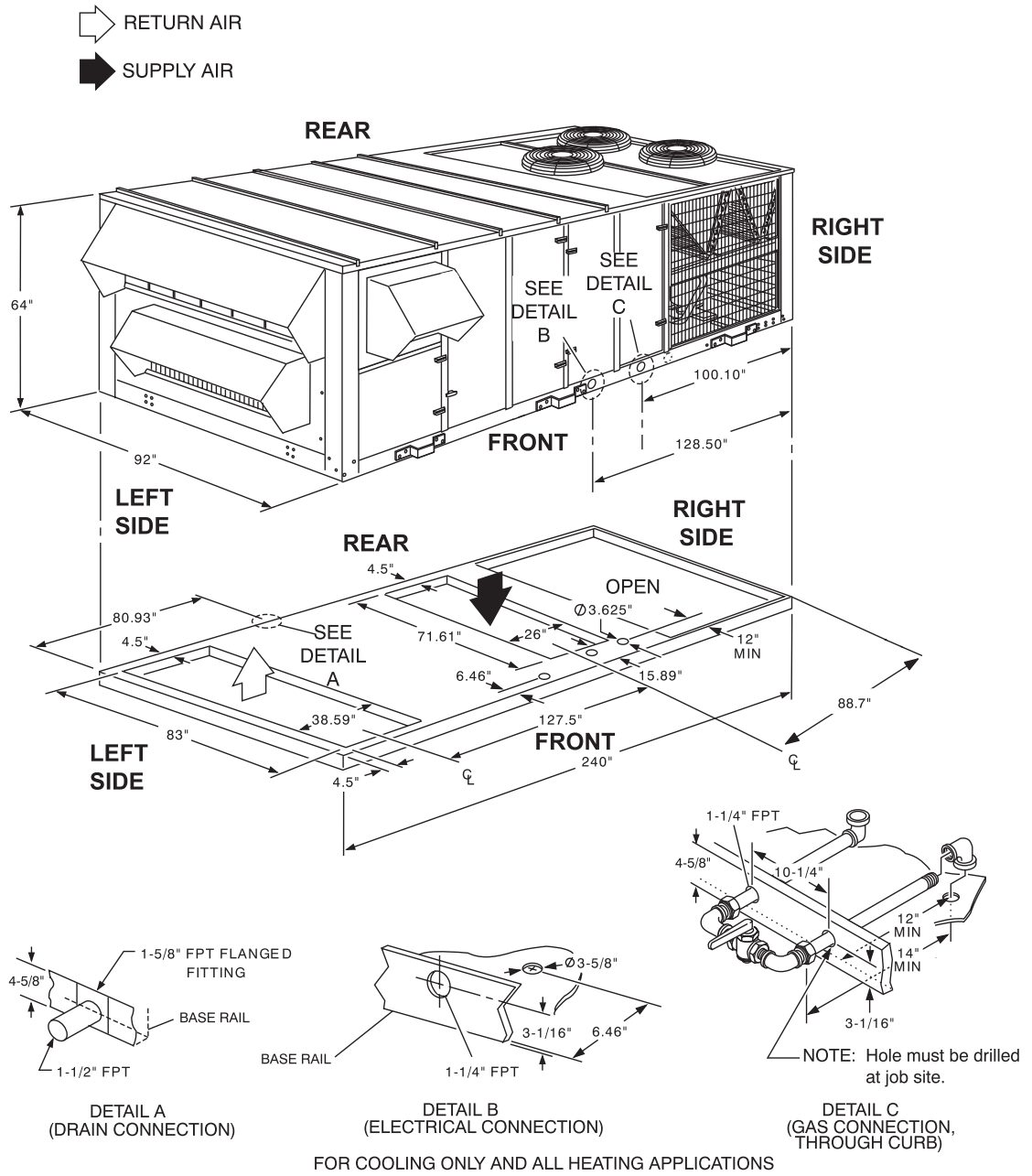

FIGURE 30 - BOTTOM SUPPLY AND RETURN

FRONT SUPPLY: FOR COOLING ONLY APPLICATIONS
 REAR SUPPLY: FOR COOLING ONLY OR GAS HEAT APPLICATIONS

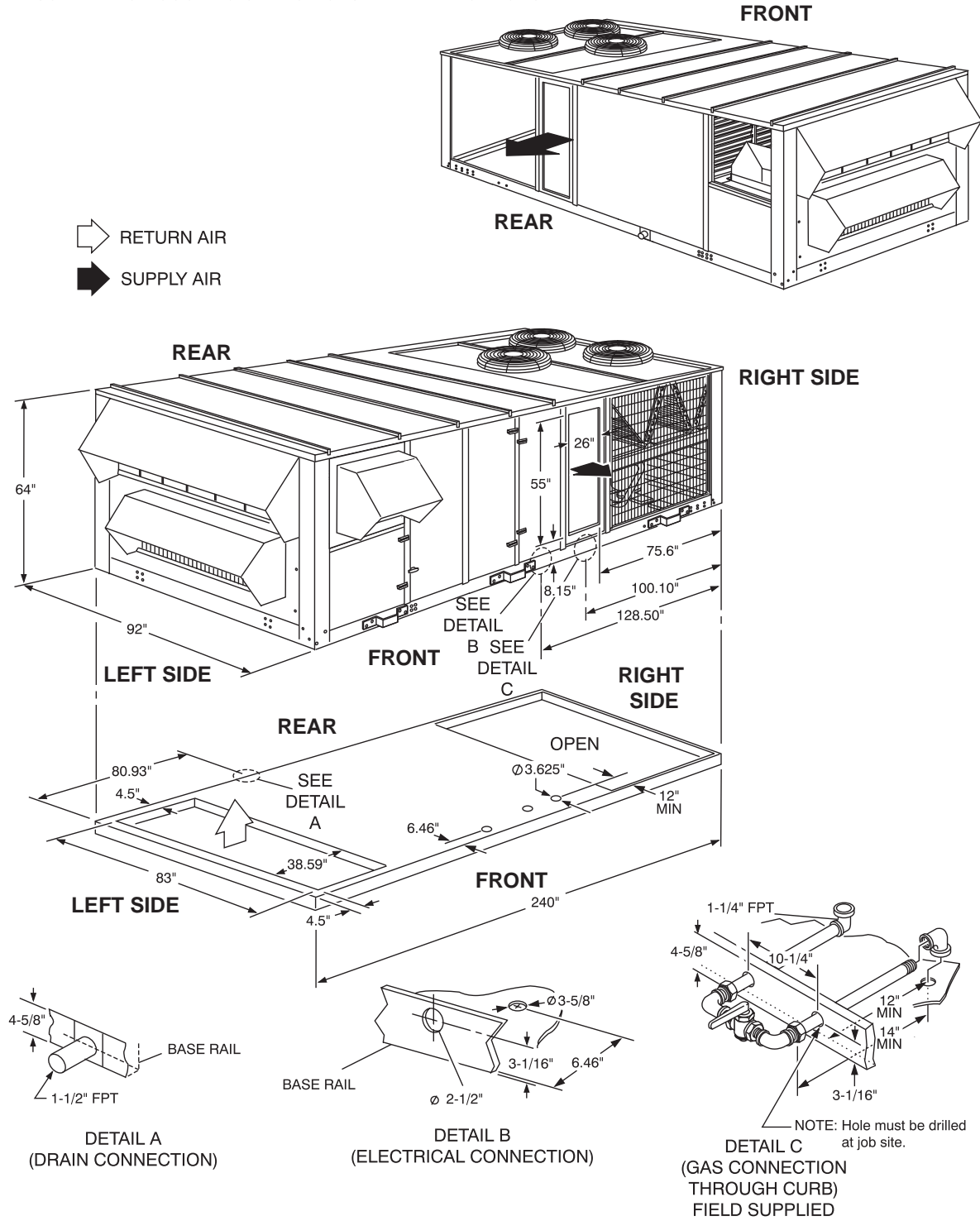

FIGURE 31 - BOTTOM RETURN, FRONT & REAR SUPPLY

FRONT SUPPLY: FOR COOLING ONLY APPLICATIONS
 REAR SUPPLY: FOR COOLING ONLY OR GAS HEAT APPLICATIONS

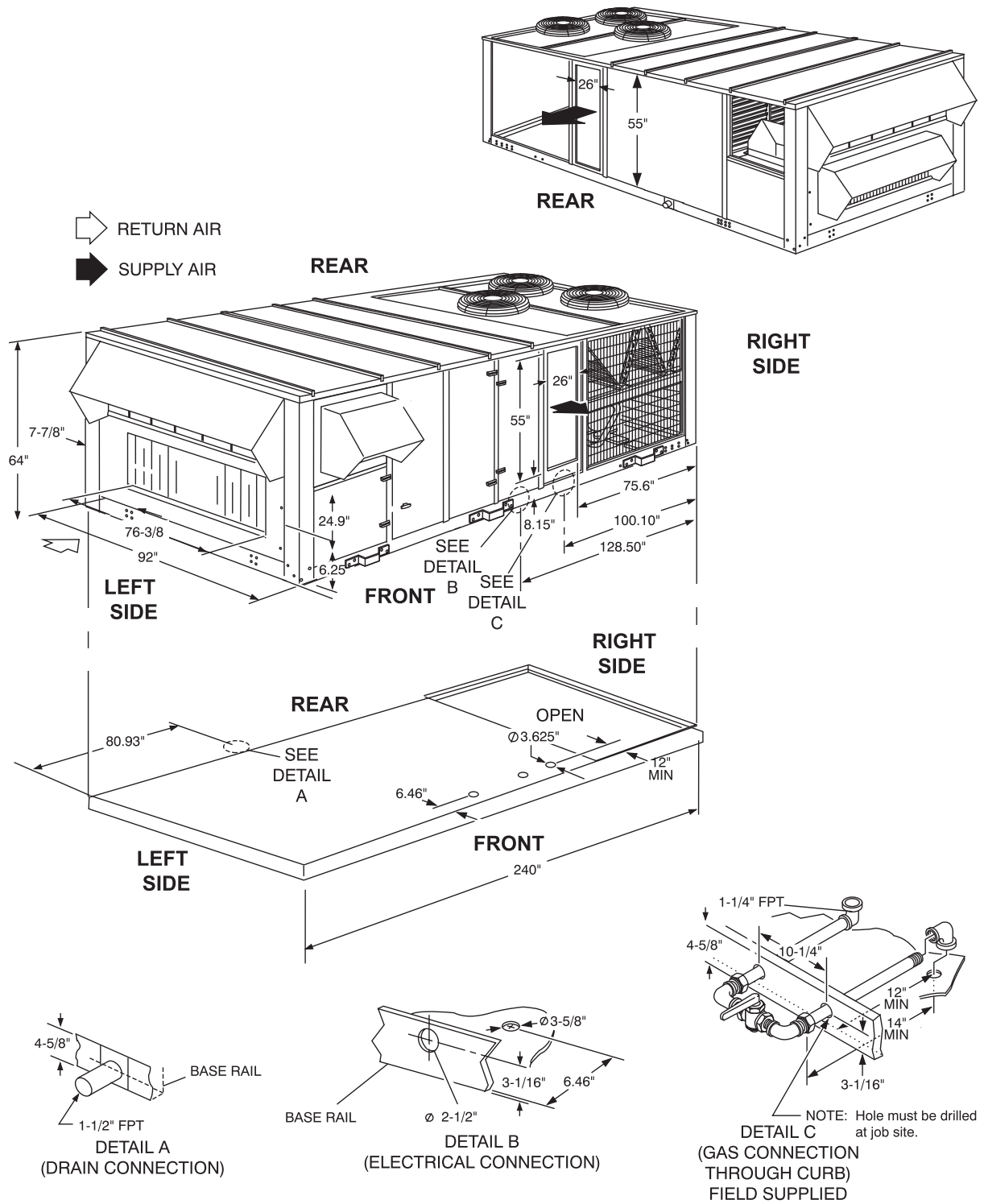

FIGURE 32 - END RETURN, FRONT & REAR SUPPLY

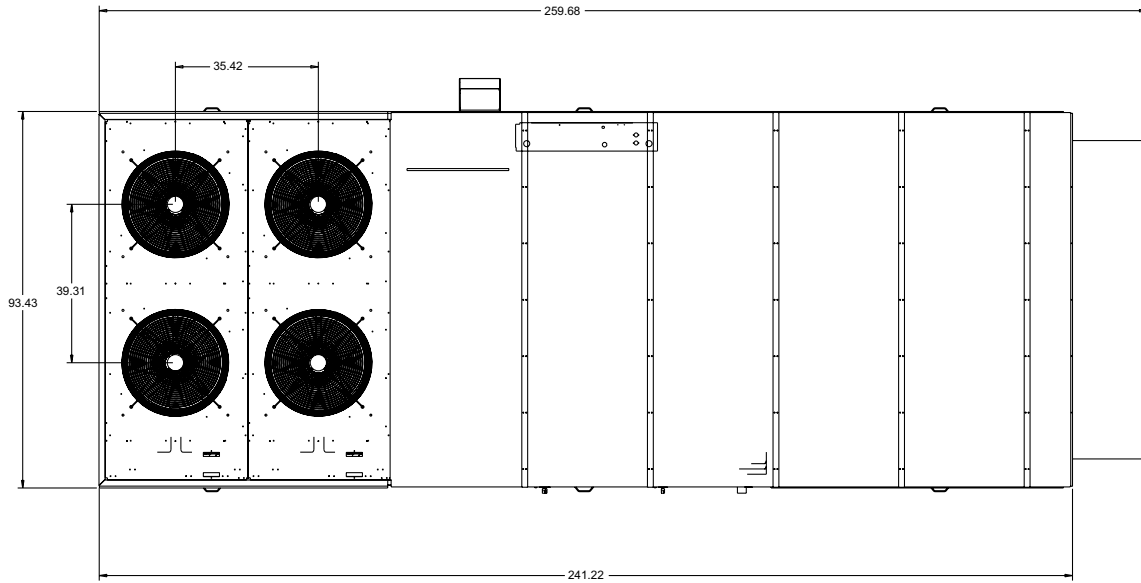

FIGURE 33 - MILLENNIUM OVERHEAD VIEW

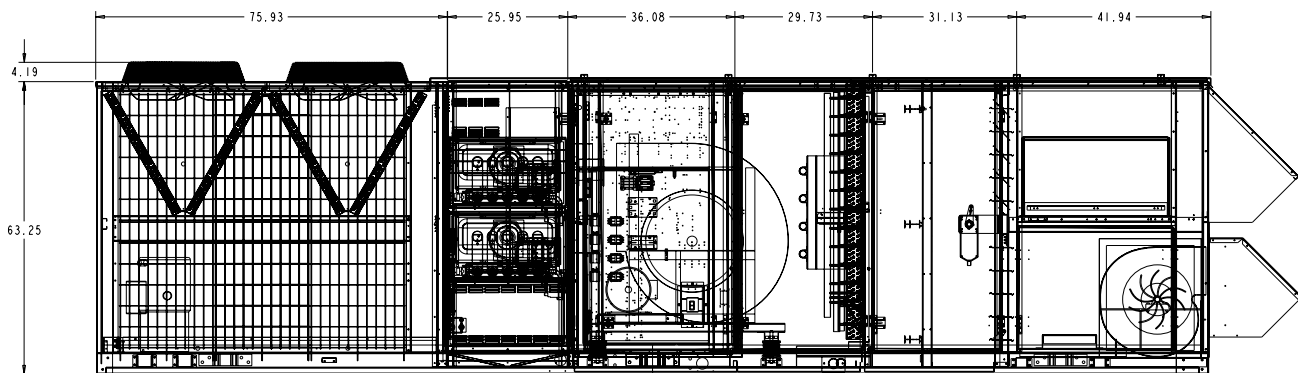

FIGURE 34 - MILLENNIUM MAJOR COMPONENT LAYOUT

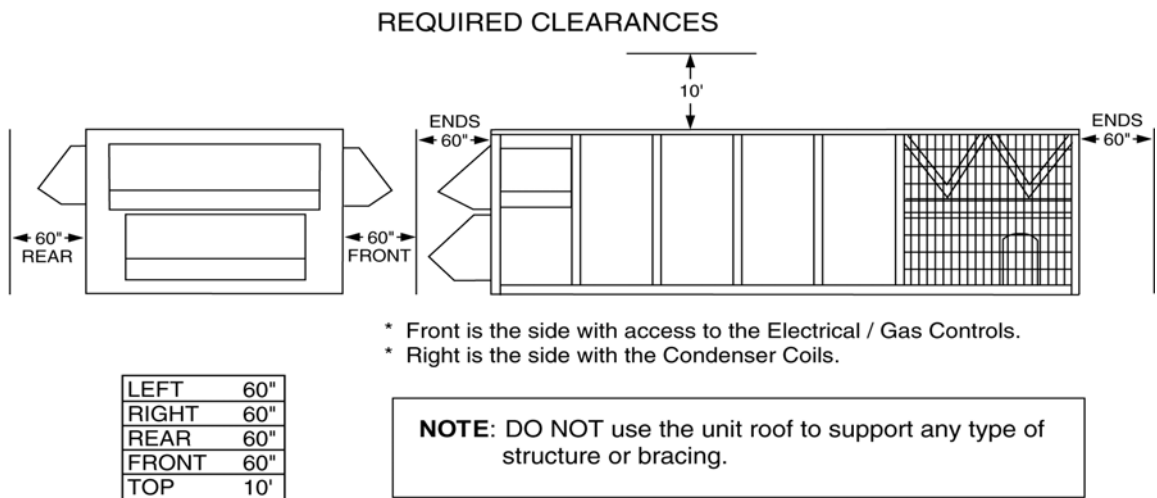

FIGURE 35 - CLEARANCES - HOOD/ECONOMIZER & MOTOR DRIVE - SIDE

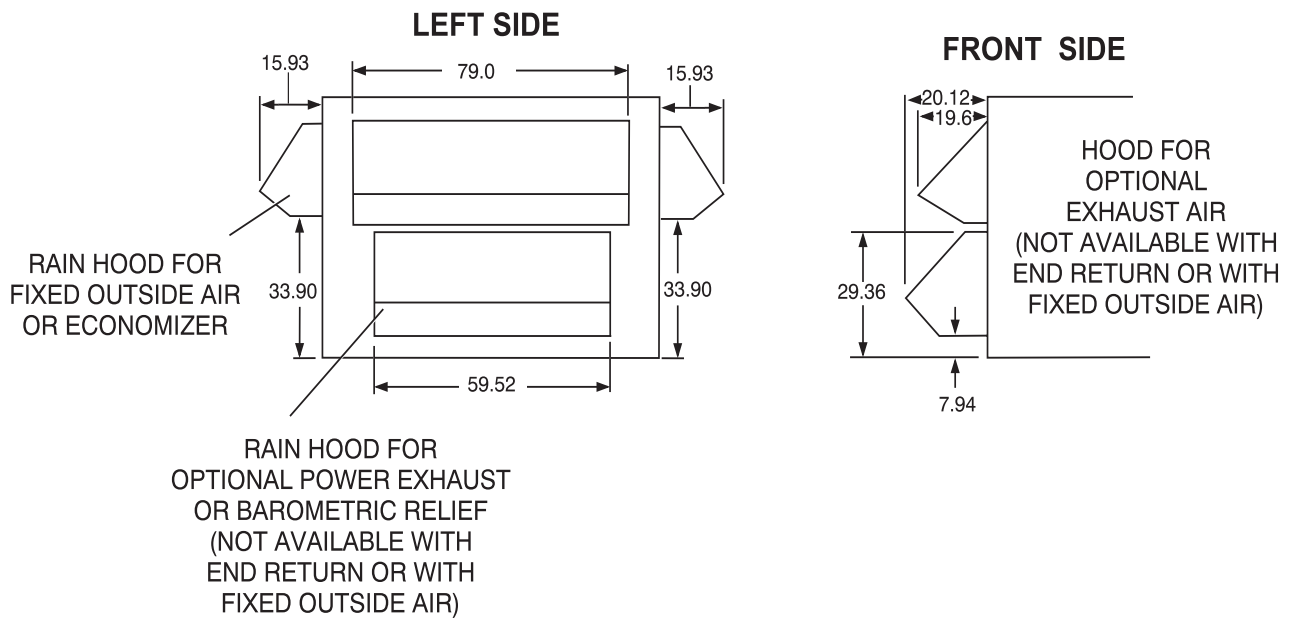
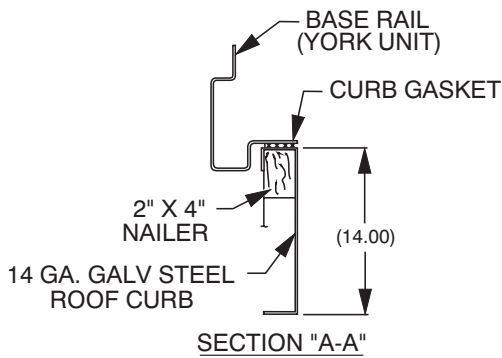
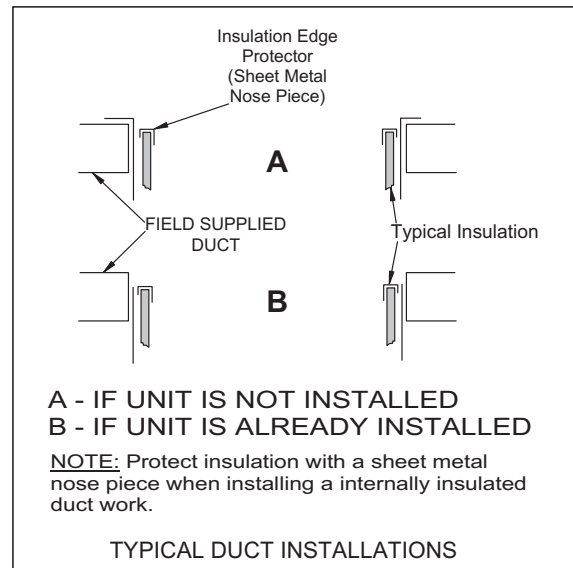
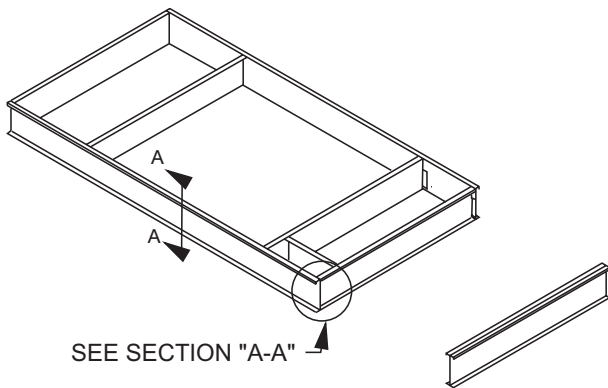
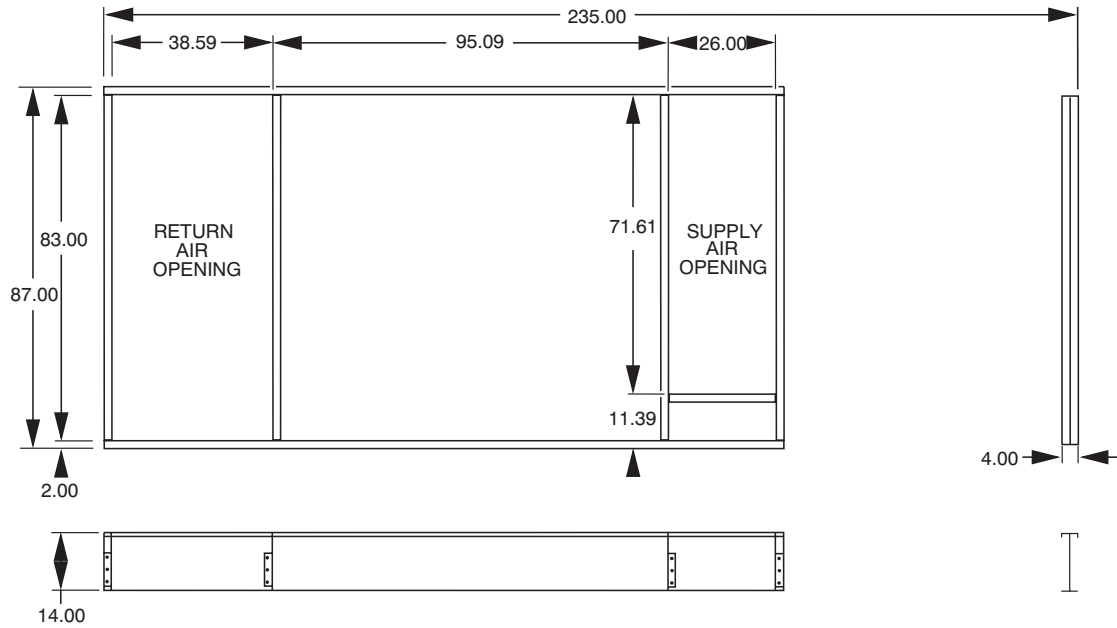

FIGURE 36 - CLEARANCES - HOOD/ECONOMIZER & MOTOR DRIVE - FRONT & END



BASE RAIL CROSS-SECTION

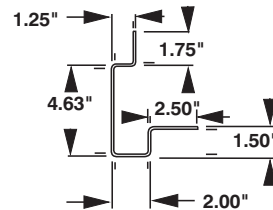
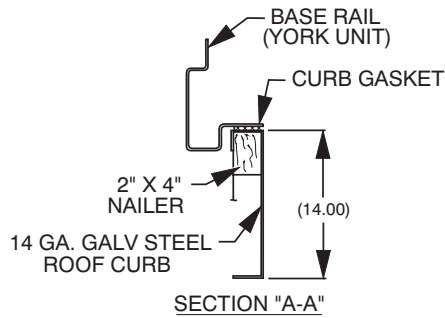
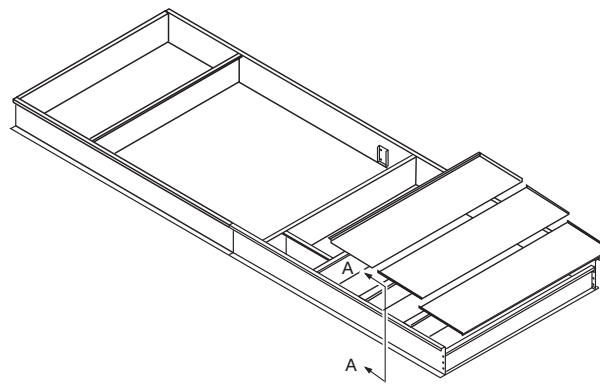
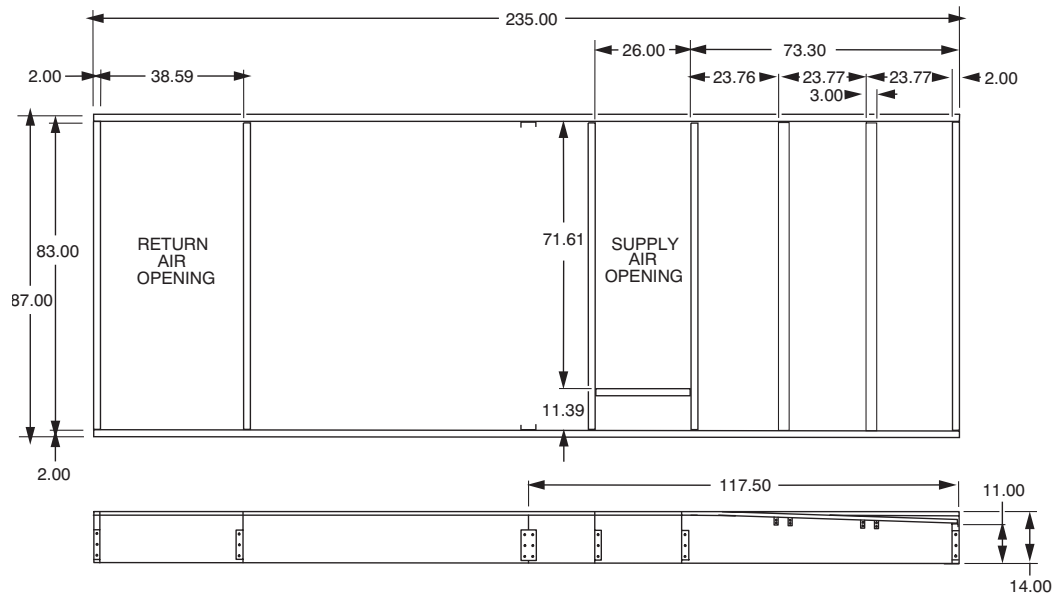

FIGURE 37 - PARTIAL ROOF CURB MODEL 1RC0455P



BASE RAIL CROSS-SECTION

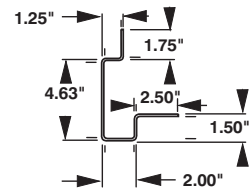

FIGURE 38 - FULL ROOF CURB MODEL 1RC0455F

GUIDE SPECIFICATIONS - YORK MILLENNIUM 25, 30, & 40 TON UNITS

GENERAL

Units shall be manufactured by York International Unitary Products Group in an ISO 9001 certified facility. Introducing the YORK Millennium 25, 30, & 40 ton rooftop line - units designed to provide peak performance and value both today and for years to come. Millennium units are manufactured at an ISO 9001 registered facility, and each rooftop is completely computer-run tested prior to shipment. The Millennium is designed to be flexible enough to meet your needs today and in the future. The true value of York's Millennium is that it can be designed to fit any need, from cooling only, constant volume applications to variable air volume systems with variable frequency drive.

DESCRIPTION

Supply York Millennium packaged rooftop system in accordance with the capacities in the plans. Units shall be rated by the manufacturer at a minimum (30/40 Ton units: 9.5 EER / 25 Ton units: 10 EER) according to ARI 360. Units shall be shipped in a single package, fully charged with R-22 refrigerant. The manufacturing facility shall be registered under ISO 9001 Quality Standards for Manufacturing. Units shall carry both ETL and CGA safety approval ratings. Tags and decals to aid in the service or indicate caution areas shall be provided. Installation and maintenance manuals shall be supplied with each unit. Units shall be capable of providing mechanical cooling down to 40°F (0°F with low ambient kit). Unit shall be capable of starting and running at 120°F. Unit electric and gas connections shall be either through the curb or the side of the unit.

CONSTRUCTION

Base

The base rail shall be constructed of 12 gauge galvanized steel, extending the full perimeter of the unit. All components shall be supported from the base, and the base shall include integral lifting lugs. The unit base rail shall overhang the roof curb for water runoff and shall have a fabricated recess with a continuous flat surface to seat on the roof curb gasket, providing a positive, weather tight seal between the unit and the curb.

Casing

The unit cabinet shall be double wall construction to provide both maximum resistance to bacterial growth in the air stream and superior structural integrity. All sheet metal shall be G90 mill galvanized sheet metal, formed and reinforced to provide a rigid assembly. Sheet metal shall be cleaned in an alkaline and zinc phosphate bath, and the exterior surfaces shall be coated with a 1.5 mil powder paint, capable of withstanding 1000 salt spray hours in accordance with ASTM B-117. The unit shall be insulated with 1-1/2," 1 pound fiberglass insulation between the two sheet metal skins. Insulation shall meet

NFPA-90A regulations for smoke and flame spread ratings. The cabinet corner post and the intermediate side supports shall be 16 gauge steel. All access doors shall be 18 gauge on the exterior surfaces, and 20 gauge on the interior. Floor shall be 18 gauge, and 24 gauge. All serviceable sections shall have hinged access doors with latches on both sides of the unit. All access doors shall be constructed of 20 gauge steel on the outside, with 24 gauge on the inside. Each door shall seal against a rubber gasket to prevent air and water leakage. The roof shall be double wall, with 18 gauge on the external surface and 24 gauge on the interior. The roof shall be formed with a 45 degree drip lip overhanging the sidewalls to prevent precipitation drainage from streaming down the side of the unit. Roof sections shall be connected together via integral channels fastened with screws and sealed with rubber gasketing. Each fastened seam shall be further protected by a sheet metal channel covering the full length of the gasket surface, making a completely water tight seal.

SUPPLY AIR SYSTEM

SUPPLY AIR FAN

Fans shall be centrifugal type, statically and dynamically balanced in the factory. Fan wheels shall be designed for continuous operation at the maximum rate of fan speed and motor HP. The fan and motor assembly shall be mounted on a common base to allow consistent belt tension with no relative motion between the fan and motor shafts. The entire assembly shall be isolated from the unit base with 1" (or 2" optional) deflection springs. The fan discharge shall be connected to the cabinet through a reinforced neoprene flexible connection to eliminate vibration transmission from the fan to the unit casing. Fans shall be double-width, double-inlet with forward curved blades. Fan wheels shall be a minimum of Class II construction.

OPTIONAL

On variable air volume units without variable frequency drives, fans shall be provided with heavy gauge, corrosion resistant blades, with zinc-plated steel inter-locking operating mechanism. Both inlet vanes must operate from a single shaft and be synchronized for precise control.

Units equipped with variable frequency drive on supply fan must be controlled by a duct static transducer providing a 2-10 VDC signal to the drive. Supply fan variable frequency drives shall have factory option of being equipped with a manual drive bypass.

BEARINGS AND DRIVES

Bearings shall be self-aligning pillow-block re-greasable ball bearings with an average life expectancy of 200,000 hours. Grease fittings shall be accessible through access doors. Fan motors shall be NEMA designed, Standard efficiency (option, Hi-efficiency) ball bearing type with electrical characteristics and horsepower as specified. Motors shall be 1750 RPM, open drip proof type. The motor shall be located within the unit on an adjustable, heavy steel base. All fan motor drives

shall be selected for a minimum service factor of 1.2 and have fixed pitched sheaves.

AIR FILTERING SYSTEM

All filter holding frames shall be of heavy duty construction designed for industrial applications. All filters shall be either side accessible or front loading with access doors provided on both sides of the filter section. All filter media shall be Class II listed under UL Standard 900. Filter efficiencies shall be rated in accordance with ASHRAE Standard 52-76 2" Throwaway Filters with fiberglass media multiple shall be standard

OPTIONAL

Two inch pleated, throwaway filters with 30% efficiency. Rigid filters shall be high performance, expanded area, disposable type filters. Rigid filter sections shall be preceded by a 2 throwaway prefilter assembly. Filter efficiency shall be 95% (Option: 65%) based on ASHRAE Standard 52-76.

AIR INLET SYSTEM

General

Outside Air inlet openings shall be covered by a factory installed rain hood permanently attached to the cabinet to prevent windblown precipitation from entering the unit. The rain hoods on the front and back of the unit shall be rotated into the cabinet and secured for shipment so that upon installation they need only be rotated upwards and screwed into place. The outside air hood shall contain a removable and cleanable filter with an efficiency rating of 50% based on ASHRAE 52- 76. All damper assemblies shall be of low leak design. Damper blades shall be fabricated from a minimum of 16 gauge galvanized steel. Blade ends and edges shall be covered with vinyl seals. Damper shafts shall be fabricated from solid steel and mounted in the frame with bronze bearings. On all units not equipped with an economizer, an option shall be available for a manually adjustable outside air damper shall be capable of admitting 0-25% outside air.

Economizer (Optional)

An economizer shall have outdoor air and return air dampers that are interlocked and positioned by fully modulating, solid state damper actuators. The actuators shall be spring loaded so that the outside air damper will close when power to the unit is interrupted. The operation of the economizer shall be fully integrated into the cooling control system. The economizer shall be available for control via a dry bulb sensor (Optional: single or dual enthalpy sensors).

RELIEF SYSTEM (Optional)

All units with relief must have an economizer.

Barometric Relief (Optional)

Building air exhaust shall be accomplished through barometric relief dampers installed in the return air plenum. The

dampers will open relative to the building pressure. The opening pressure shall be adjustable.

Exhaust Air Fans (Optional)

General - forward curved centrifugal fan(s) shall be installed in the return air plenum for positive power exhaust. Fans shall be on a common shaft, driven by a single motor. The fans, motors and drives shall be of the same quality and design as specified for the Supply Air Fan, except the fans shall be Class I. Fans shall be capable of exhausting up to 100% of the nominal CFM of the unit. Non-modulating Exhaust - Units with non-modulating power exhaust shall have a barometric relief damper to prevent outside air from entering in the off cycle. The fans shall cycle on and off with building pressure. Modulating Operation - The fans shall be capable of modulating the amount of air from 0% to 100% of nominal CFM. Modulation shall be through discharge dampers or variable frequency motor speed modulation. Dampers or VFD shall be controlled by static pressure in the conditioned space or return air duct.

HEATING SYSTEM

Gas-fired Heating Section (Optional)

One or more gas-fired heating modules shall be installed to provide the heating requirements per the schedule shown on the plans. The heat exchanger shall be of tubular design. Tubes shall be 2 1/4 OD and constructed of minimum 20 gauge, G160 aluminized steel (1.6 mil aluminum silicone alloy) for corrosion resistance (Optional: 409 Stainless Steel). Flue baffles shall be made of 430 stainless steel. Each gas-fired heat module shall have an induced draft combustion fan with energy efficient intermittent pilot spark ignition and redundant main gas valves with pressure regulator. Units with standing spark ignition shall not be acceptable. An induced draft fan shall be provided to maintain a positive flow of air through each tube, to expel the flue gas and to maintain a negative pressure within the heat exchanger relative to the conditioned space. Induced draft fans shall be direct-drive. One (1) high limit controller per heating module, with automatic reset to prevent the heat exchanger from operating at an excessive temperature will be installed. A centrifugal switch on the induced draft fan motor shaft must be provided to prevent ignition until sufficient air flow is established through the heat exchanger. Secondary airflow safety shall be provided by rollout switch protection. The rollout switch shall discontinue furnace operation if the flue becomes restricted. Units shall ship with an external flue to be shipped in the unit and mounted on the job site. The flue shall discharge products of combustion above the unit, preventing recycling of corrosive combustion gases back through the heat exchanger. Gas heating sections shall be both ETL and CGA approved to both US and Canadian safety standards.

Electric Heating Section

An electric slip-in heater shall be installed within the rooftop unit to provide the heating requirements per the schedule shown on the plans. The electric heater shall be wired in such a manner as to provide two equal steps of capacity (80 and

108 kW) or a single step of capacity (40 kW). The furnace shall be an industrial grade design using an open coil(s) made of the highest grade resistance wire containing 80% nickel and 20% chromium. The resistance coil(s) shall be adequately supported in the air stream using ceramic bushings in the supporting framework. Terminals of the coil(s) shall be stainless steel with high temperature ceramic bushings. The primary high temperature protection shall be an automatic reset type thermal cut out. Secondary protection shall be an automatic reset type thermal cut out. Secondary protection shall be a replaceable thermal link. The operation of the electric heater shall be an integral part of the roof top control system. Power connection to the strip heater shall be through the single power point connection for the entire unit. Electric heat shall be ETL certified to both US and Canadian safety standards.

Hot Water Heating Coil

The manufacturer shall furnish and factory install a hot water coil in the rooftop units, as described in the following specifications. Water coil capacities and pressure drops shall be certified in accordance with ARI Standard 410. The hot water coil shall have eight fins per inch, 2 tubes per circuit, and an inlet and outlet connection. Primary surface shall be 1/2" OD copper tube, staggered in direction of airflow. Tubes shall be mandrel expanded to form fin bond and provide bur-nished, work-hardened interior surface. Return bends shall be die formed and silver-brazed to tubes. Headers shall be of heavy seamless copper tubing, silver-brazed to tubes. Connections shall be of red brass, with male pipe threads, silver brazed to headers. Connections also have 1/4" FPT drain plug on each connection. Extended surface shall consist of die-formed, continuous, aluminum fins with formed channels, and surface treatment to minimize moisture carry-over. Fins shall have fully drawn collars to accurately space fins, and to form a protective sheath for the primary surface. A structural galvanized steel casing shall protect the coil. Tube sheets on each end shall have drawn collars to support tubes. An intermediate coil support shall be provided. The coil shall be circuited to provide free draining and venting, through one vent and drain. Completed coil, including headers, connections and return bends shall be tested with 325 pounds compressed air under water. Coils shall be designed for operation at 250 psig design working pressure.

Steam Heating Coil

The manufacturer shall furnish and factory install a steam heating coil in the rooftop units, as described in the following specifications. Steam coil capacities and pressure drops shall be certified in accordance with ARI standard 410. The steam coil shall be constructed in the non-freeze style. The steam coil shall have six fins per inch, and 2" inlet, and 1 1/2" outlet connection. Tubes shall be 1" OD seamless copper tubing with a minimum wall thickness of 0.035" and expanded into the fin collars for maximum fin-tube bond. Inner distributing tubes shall be 5/8" OD seamless copper tubing with a minimum wall thickness of 1/4". The copper to copper joints shall be joined with high temperature, silver solder. Corrugated fins with integral spacing collars shall cover the entire tube surface. Headers shall be constructed of seamless copper. The

header tube holes shall be extruded providing better tube to header contact for a stronger braze connection. All header connections shall be of red brass or steel, with male pipe threads and silver braze to headers. Casing shall be 16 gauge galvanized steel. Chafing shall be prevented by extruding and flaring the holes in the tube sheet and intermediate tube sheet. The core shall be pitched in the direction of the condensate connection for proper drainage. The completed coil (including headers and connections) shall be tested underwater with 325 lbs. compressed air to ensure a leak free coil.

REFRIGERATION SYSTEM

Units shall have two (25 ton), three (30 ton) or four (40 ton) independent refrigerant circuits for maximum load-matching capability. Each refrigerant circuit shall be controlled with a balance-port thermal expansion valve for maximum control at low load conditions.

Evaporator Coils

Evaporator coils shall be direct expansion type with intertwined circuiting to assure complete coil face activity during part load operation. Coil tubes shall be 3/8 OD copper, internally enhanced tubes. Fins shall be enhanced aluminum mechanically expanded to bond with the copper tubes. Coil casing shall be fabricated from heavy gauge galvanized steel. All coils shall be pressure tested at a minimum of 450 PSIG. A stainless steel drain pan shall be provided under the entire length and width of the evaporator coil, including all return bends. The main drain pan shall be sloped a total of 1/4 per foot towards the drainage point. Main drain pan shall be easily cleanable in the field. The condensate drain opening shall be flush with the bottom of the drain pan to allow complete drainage. Coils in excess of 48 high shall have an intermediate drain pan, also fabricated of stainless steel extending the entire finned length of the coil to provide better water drainage. Drainage from the intermediate drain pan shall be to the primary drain pan. OPTIONAL: Evaporator coils shall be protected by the Technicoat 10-1 four coat process. Coils shall be dipped in a phenolic coating, which provides substantial resistance to corrosion of aluminum and copper.

Compressors

Units shall have two (25 ton), three (30 ton) or four (40 ton) industrial duty hermetic scroll compressors, independently piped and charged. Compressors shall have an enlarged liquid carrying capacity to withstand rugged operating conditions. Compressor frame shall be cast iron, with cast iron fixed and orbiting scrolls. Each compressor shall feature a solid state protection module, designed to protect the compressor from over temperature and overcurrent conditions. Each compressor shall include the following safety and convenience devices: replaceable suction screen, discharge line check valve, and oil sight glass. Compressors shall be vibration isolated from the unit, and installed in an easily accessible area of the unit.

Condenser Coils

Condenser coils shall have 3/8 seamless copper tubes, arranged in staggered rows, mechanically expanded into aluminum fins. Coils shall be protected from hail damage with a V configuration, with individual flat coils rotated 30 from the vertical plane for each condensing circuit. Condensing coils shall have an integral subcooler for more efficient, stable operation. OPTIONAL: Condenser coils shall be protected by the Technicoat 10-1 four coat process. Coils shall be dipped in a phenolic coating, which provides substantial resistance to corrosion of aluminum and copper.

Condenser Fans and Motors

Condenser fans shall be direct drive, propeller type, discharging vertically. Condenser fan motors shall be 3 phase, totally enclosed air over (TEAO) type, with built in thermal overload protection.

Refrigerant Piping

All interconnecting piping between refrigeration components shall be copper tubing with brazed joints. Each refrigerant circuit shall be equipped with liquid line filter drier, and moisture indicating sight glass. Each circuit shall also have both high and low pressure switches installed on either side of the compressor and include schrader depressors for replacement of the pressure switches without removing charge. All small diameter distributor tubing to the evaporator coil shall be protected by polyurethane sleeves over the length of the tubing to prevent the tubes from copper-to-copper contact during shipment or operation.

Hot Gas Bypass (Optional on CV; standard on VAV)

Unit shall have hot gas bypass factory installed on the lead compressor.

CONTROLS

GENERAL DESCRIPTION

Equipment with Simplicity as standard shall be factory run-tested through the control, after the test is complete; there will be no wires to re-connect. All control wiring points shall be tested and verified through communication.

The control shall be UL or CSA recognized. The control shall be manufactured in a manufacturing facility that is certified to ISO 9001.

COMPRESSOR CONTROL

The control shall have a five-minute Anti-Short Cycle Delay to prevent excessive compressor cycling. The control shall have a three-minute minimum run time to insure that oil gets returned to the compressor each time it starts. The minimum runtime shall be programmable up to 10 minutes.

The control shall monitor the High Pressure switch, the Low Pressure switch, and the Compressor Overloads separately for each refrigeration circuit. The control shall have a 30 sec-

ond Low Pressure Switch bypass when it starts any compressor.

A hard compressor lockout shall occur if the control detects the same switch trip three times in a two-hour window, which starts when the first trip occurs. On the first and second trips, the control will turn the compressor off and wait five-minutes after the switch re-closes, before restarting the compressor.

The control shall be capable of operating both compressors and the economizer when there is a call for both stages of cooling.

The control shall have a means of locking out mechanical compression below a programmable low ambient trip point. This must be done without adding extra components to the unit.

The control shall have a means of locking out the mechanical compression when the economizer is operating in free cooling mode without additional components

The control shall have a means of starting the compressor before the indoor Fan comes on when operating with a Thermostat in the AUTO FAN mode.

FAN CONTROL

The control shall have fully adjustable Fan ON and Fan OFF delays for both Heating and Cooling settable at the control or via communication.

The control's default Fan OFF delay for Cooling shall be 30 seconds to take advantage of the remaining capacity in the coil after the compressor has been turned off.

The control shall lock on the Fan if the high temperature limit trips three times in one hour of operation.

The control will have a software programmable Fan Mode Switch for Auto operation or Continuous operation.

When the Fan is in the Continuous mode, it will run continuously during the occupied schedule and in the Auto mode when in an unoccupied schedule.

The control shall be capable of operating the fan without a G or fan signal from the thermostat.

EQUIPMENT CONTROL FEATURES

The control shall be capable of communicating on the Standard Open protocol, MODBUS RTU.

The register data for the MODBUS must be publicly available and open.

Monitoring Software shall be provided at no cost. The monitoring software shall have a flashing icon when any unit wired to the computer has an alarm. Clicking the flashing icon shall display the fault code and the details of the fault.

The networking setup shall be completed by connecting a three-wire daisy chain cable to each unit, then powering all the units up and pushing a button on each control. There shall not be any dipswitches to configure the network address.

The control shall use a communication driver that is capable of having 64 nodes on the bus before a repeater is needed.

The control shall use non-volatile memory to store the last five alarms. There shall be a single button to push to recall these last five alarms. The alarms shall be stored first in last out. The first flash code shall be the last alarm that occurred. There shall be a button press sequence to clear the alarms in non-volatile memory.

The control shall have a button to reset compressor lockouts without powering the unit down.

The control shall have a button to clear compressor Anti-Short Cycle Delays. When this button is pressed it will only clear the Anti-Short Cycle Delays for one cycle only and not permanently.

The control will be compatible with any BAS (Building Automation System). Any BAS shall be able to control the equipment when wired to the control's Thermostat Terminal Strip.

The control shall have loading of at least 25 milliamps on all thermostat inputs for controllers and thermostats that use output TRIACs.

The control shall have a Smoke Detector Shutdown input on the board. The control shall be powered through this input, so when the Smoke Detector trips, the control will shut down the unit immediately.

The control will have low voltage protection for the contactors and will not energize a contactor if the voltage is below 19.2 VAC, to insure contactor pull-in. If the control has a compressor contactor energized when the voltage drops, it shall not de-energize the contactor until the voltage drops below 16 VAC, which is the drop out voltage for most contactors.

The control shall have a means of low ambient control without adding any additional components. The control shall have a means of cycling the compressor on for 10 minutes and off for 5 minutes to defrost the indoor coil when the outside ambient is below a low ambient switch point without adding additional components.

The control shall have a means of storing compressor run time. This data shall be available through communication. The control shall have the ability to clear this data when a compressor is replaced.

The control shall have the ability to store a name of at least 26 characters in length. The control will leave the factory with the serial number of the equipment it is in, stored in non-volatile memory in the Name location.

The control shall have the ability to store the model number of the equipment of at least 26 characters in length. The control will leave the factory with the model number of the equipment it is in, stored in non-volatile memory.

The control shall have the ability to store the serial number of the equipment of at least 26 characters in length. The control will leave the factory with the serial number of the equipment it is in, stored in non-volatile memory.

The control shall not power the contactors through the thermostat wiring. Dropping voltage over the thermostat wiring causes chattering contactors when the contactors are powered in this manner.

The control will operate and monitor up to 3 stages of heat independently.

The control shall monitor the Gas Heat operation in the heating mode. It shall monitor the gas valve when there is a call for heating. The control shall alarm when there is a call for heat and no gas valve voltage after 5 minutes.

There will only be one control board for this series of units, for both CV and VAV operation.

COMFORT CONTROL FEATURES

The control will be installed and tested at the factory where the equipment is assembled.

The control will use a Wall Sensor that has a means of overriding the unoccupied mode for a programmable amount of time.

The Unoccupied Override time will be programmed in minutes up to 4 hours.

The control will use a Wall Sensor that has a warmer/cooler dial so the occupants can offset the programmed setpoint by a programmed amount between 1 and 5 degrees.

The control will have a Supply Air Sensor as standard.

The control will have a Return Air Sensor as standard.

The control will have an Outside Air Sensor as standard.

The control will use the Return Air Sensor in place of the Space Sensor if the Space Sensor fails for any reason, the control will have a 365 day Real Time Clock.

The Real Time Clock will be able to do automatic Daylight Savings Time adjustment.

The control will have an Occupancy Schedule that allows two different Occupied schedules per day for each of the seven days of the week individually.

The control will have 20 Holiday Schedules, each capable of 99 days.

The control's Holiday Schedules will have a start time associated with each schedule.

The control will control the Economizer directly.

The control will be capable of operating the Economizer using Dry Bulb, Outside Enthalpy, or Differential Enthalpy.

When the control is using Enthalpy to control the Economizer, it will also have an Outside Air Temperature enable Setpoint.

The control will use two setpoints for Supply Air Temperature for the Economizer operation. One will be for a small space cooling demand and one for a large space cooling demand.

The control will have the ability to do Demand Ventilation using one CO₂ sensor.

The control will have a programmable maximum Outside Air Damper Position for IAQ operation.

The control will have the ability to temper the ventilation air during times when heating or cooling is not required.

The control will have the ability to offset the operating setpoint based on high Humidity in the Space.

The control will have programmable limits when offsetting the Operating Setpoint to control Humidity.

The control must be able to lockout Cooling below a programmable Outside Air Temperature Setpoint.

The control will be able to lockout Heating above a programmable Outside Air Temperature Setpoint.

The control will have a Space Temperature Alarm.

The control will have a Supply Air Temperature Alarm for Heating and Cooling. The Alarm temperature will be programmable

The Control will be able to do a Pre-Occupancy Purge at a Programmable Time.

The control will have a hardware Smoke-Purge input.

The control will have the ability to read a dirty filter switch

The control will have the capability of reading a Fan proving switch.

The control will have an intelligent recovery function that will bring the space to the Occupied Setpoint just before or at the beginning of the first Occupied schedule each day. The control will learn and apply the minimum run time required to heat

or cool the space to setpoint for the first Occupied period of a day.

The control will have Software controllable Mode Switches (Heat, Cool, and Fan).

The control will meter and track Unoccupied Override Time for billing purposes.

AVAILABLE ACCESSORIES

The following accessories shall be available:

Full perimeter and partial perimeter roof curbs

14" high roof curb with wood nailer. Roof curb covers the entire perimeter of the unit (full curb) or that portion of the unit, which has airflow (partial curb).

Burglar Bars

This accessory mounts in the supply and return opening of either the full or partial perimeter curb to prevent entry into the building through the ductwork.

Field Installed Barometric Relief

This accessory is a set of barometric relief dampers and hood used for the millennium barometric relief option that is fully assembled for mounting to return ductwork. This accessory is intended for use on horizontal return applications

Programmable thermostat, with or without remote sensor (required for constant volume units)

Provides 2 Heat/4 Cool control and 7 day programming.

Remote Wall Mounted Temperature Sensors

Attractive wall mounted temperature sensors are available to precisely control multiple or individual zone temperature. Sensors are available without adjustment, with override and override with programmable setpoint adjustment.

Dirty Filter Switch

A Dirty Filter pressure switch kit is available for field installation. Switches will monitor pressure drop across the units air filters and provide an alarm when filters become dirty.

Natural gas and propane conversion kits

Contains the necessary orifices and gas valve parts to convert from natural gas to propane and from propane to natural gas.

High altitude conversion kits

These kits are required for natural gas or propane applications between 2,000 and 6,000 feet.

Subject to change without notice. Printed in U.S.A.
Copyright © by Unitary Products Group 2004. All rights reserved.

036-21091-004-A-0804
Supersedes: 036-21091-003-B-0903

**Unitary
Products
Group**

**5005
York
Drive**

**Norman
OK
73069**