

INSTALLATION INSTRUCTIONS

ROOF CURB ACCESSORY MODEL# 026-33208-000 / 1RC0455P 30-40 TON OPEN CONDENSER END ROOF CURB

This Roof Curb is NRCA approved and is constructed of 14 gauge galvanized steel with a full perimeter 2" X 4" wood nailer strip. The curb is shipped with the following parts:

- A) 6 Side Panels 83 x 14
- B) 4 Side Panels 81.84 x 14
- C) 1 End Panels 26 x 14
- D) 2 Slice Channels
- E) 10 Corner Brackets
- F) 1 Hardware Package

- (72) .375-16 x 1.00 Hex Bolt w/ Nuts
- (72) .375 Helical Lock Washers
- (72) .375 Flat Washers
- (58) FT. 3/4 X 1 1/4 Foam Gasket

RETURN END SECTION OF CURB

STEP 1:

Layout the curb pieces shown

STEP 2:

Tighten the 3/8" bolts on all four (E) corner brackets making sure the corners are flush and square. Place the curb in the proper location.

Note: **MAKE SURE THE CURB SECTION IS "IN SQUARE".**

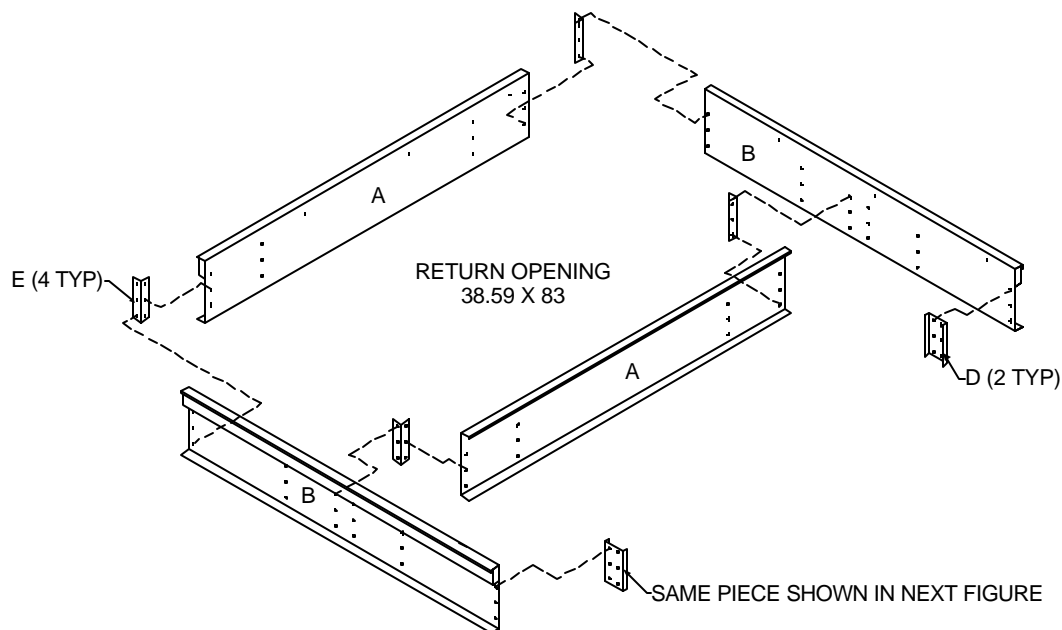

FIGURE 1

INSTALLATION INSTRUCTIONS

ROOF CURB ACCESSORY MODEL# 026-33208-000 / 1RC0455P 30-40 TON OPEN CONDENSER END ROOF CURB

STEP 3:

Layout pieces shown at end of previous section.

STEP 4:

Tighten the 3/8" bolts on all six (E) corner brackets making sure the corners are flush and square.

Note: **MAKE SURE THE CURB SECTION IS "IN SQUARE"**.

STEP 5:

Take extra two end panel (C) and bolt back to back and locate under end of condenser section.

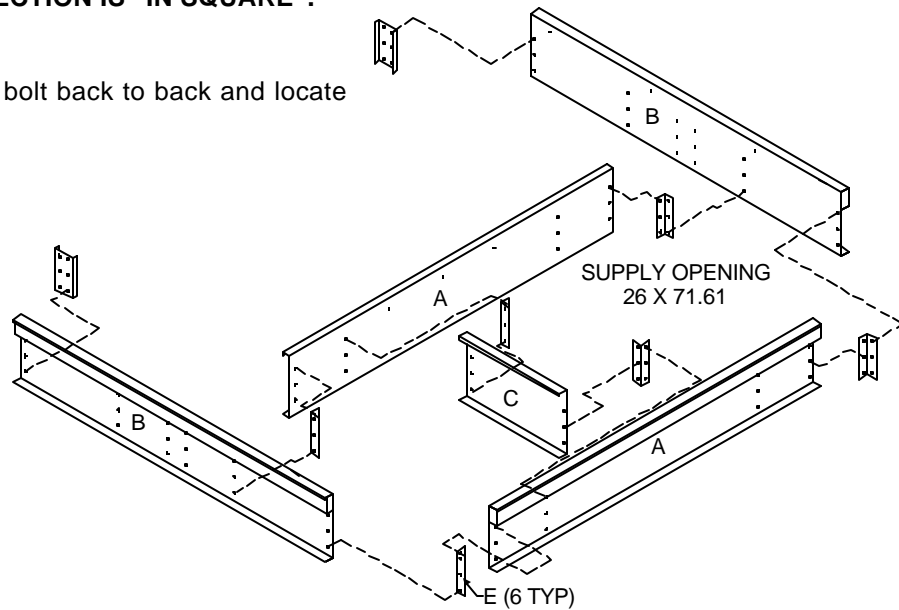

FIGURE 2

ROOFING INSTRUCTIONS

