

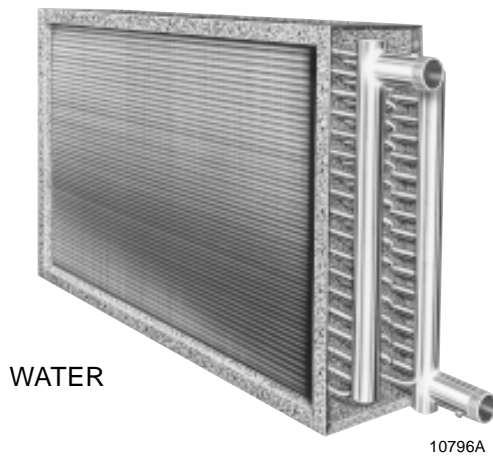

COILS



WATER

10796A

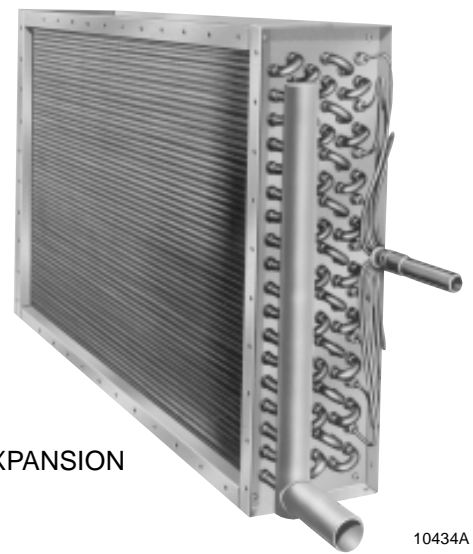

DIRECT EXPANSION

10434A

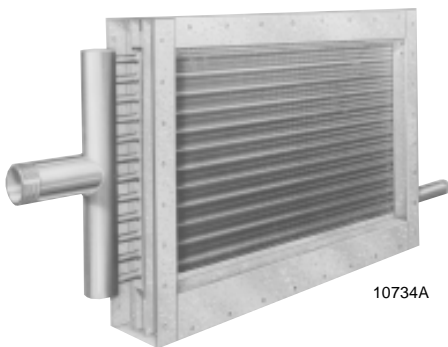

STEAM

10734A

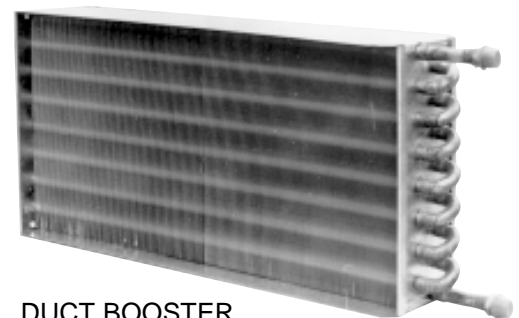

DUCT BOOSTER

23675A



Table of Contents

WATER COILS – CHILLED WATER	4
Mechanical Specifications	4
Application Recommendations	4
Guide Specifications	4
Water	5
Diagram – Water Coil	6
DIRECT EXPANSION COILS – DX	8
Mechanical Specifications	8
Application Recommendations	8
Guide Specifications	9
Diagram – Direct Expansion Coil	10
Piping Arrangements	11
STEAM COILS	12
Mechanical Specifications	12
Application Recommendations	12
Guide Specifications	13
Diagram – Steam Coil	14
Piping Arrangements	15
BOOSTER COILS – SLIP & DRIVE	16
Mechanical Specifications	16
Guide Specifications	16
Test Parameters	16
Diagram – Booster Coil	17
COIL NOMENCLATURE	20

List of Figures

FIG. 1 – DIAGRAM, WATER COILS 6

FIG. 2 – DIAGRAM, DIRECT EXPANSION COILS 10

FIG. 3 – PIPING ARRANGEMENTS 11

FIG. 4 – DIAGRAM, STEAM COILS 14

FIG. 5 – PIPING ARRANGEMENTS 15

FIG. 6 – DIAGRAM, BOOSTER COIL 18

List of Tables

TABLE 1 – BOOSTER COIL FACE AREA (sq.ft.) 18

TABLE 2 – TUBES PER CIRCUIT 18

Water Coils – Chilled Water

MECHANICAL SPECIFICATIONS

Primary Surface – 1/2" or 5/8" OD round seamless copper tubes arranged in a staggered tube pattern with respect to airflow.

Secondary Surface – Fin edges are die-formed and work-hardened to initiate immediate turbulence and to strengthen the fin edge. Tubes are mechanically expanded providing the optimum tube-to-fin bond.

Casing – The top and bottom channels and end sheets are constructed of heavy galvanized steel. Mounting holes, evenly spaced around the perimeter of the casing, are provided for attaching to ductwork or plenum chamber. Center coil supports furnished with coils having larger than 62" fin length.

Headers – Inlet and outlet headers are constructed of hard-drawn seamless copper tubing with male pipe threaded connections of red brass pipe silver brazed to headers. All supply and return connections are on the same end regardless of circuit arrangements or coil depth. Vent and drain fittings are conveniently located on the supply and return connections.

Return Bends – Constructed of (1/2" .032") & (5/8" .35") OD round seamless copper tubing with a uniform flow area throughout the radius of the bend, silver brazed to tubes.

APPLICATION RECOMMENDATIONS

1. Piping arrangement must provide for a balanced flow in multiple coil installations.
2. Casings should be installed level to ensure proper venting and draining. A spirit level is recommended for this procedure.
3. Connect the water supply to the header connection on the LEAVING AIR side of the coil, to achieve counterflow of water and air. Return water will be connected to the other header connection. Locating dimensions for connections are common to all YORK water coils.
4. Coils used in dehumidifying duty and banked two or more high must have a drain trough installed on each coil. Tubing should be provided to drain the upper pans into the main drain pan. Lower coils should have a drain pan that extends beyond the casing and headers (a minimum of 10 inches beyond the leaving face of the coil). The drain pan must be elevated to provide free drainage of condensate and to provide ample space for installation

of a trap in the drain line, to overcome pressure in the coil casing.

5. Positive coil freeze protection must be used in installations where any part of the water coil is subjected to air temperatures of 32°F or lower. This may be accomplished by use of a suitable antifreeze solution. If the coil is not in use, complete drainage of the water, assisted by adequate blowout with compressed air, is recommended.
6. Connecting piping, particularly on large coil banks, must be supported independently of coil headers. Provisions should be made for piping expansion, with anchor points near coil headers. Although the YORK heavy copper headers have ample strength and greater flexibility than cast headers, excessive piping movement would force deformation of the tubes at the end sheet.
7. When coil surfaces are sprayed to provide winter humidification, provisions must be made for blow-down or water treatment to avoid buildup of chemical deposits on coil fins.
8. Closed water circulating systems must have an expansion tank and/or water pressure relief valve to avoid exceeding coil design pressure due to thermal expansion.
9. Water flow may be controlled by a variety of control valves. Follow the recommendations of the control manufacturer.
10. Coils will meet performance ratings only if the airflow is uniform over the face of the coil. High velocity spots may cause moisture carry-over. Low velocity areas will not deliver the published rating. Duct and casing design must provide uniform face velocity. The entering side must produce a smooth transition from any high velocity effects. Fans blowing through the coil must have transition or baffling (as in typical multi-zone units). The leaving side of the coil is less critical, but no area may be blocked by the casing or other elements (e.g. DWDI fans with scroll near the leaving coil face).

GUIDE SPECIFICATIONS

Contractor shall furnish and install, where indicated on the plans, YORK coils as described in the following specifications:

Primary surface – shall be 1/2" & 5/8" in OD copper tube, of staggered configuration. Tubes shall be mandrel expanded to ensure a tight fin bond. Return bends shall be die-formed and brazed to tubes.

Extended surface – shall consist of die-formed continuous aluminum fins with formed channels and surface treatment to minimize moisture carryover. Fins shall have fully-drawn collars to accurately space fins, and to form a protective sheath for the primary surface.

A structural galvanized steel casing – shall protect coil during shipment and provide for stacking of coils. Tube sheets on each end shall have drawn collars to support tubes. An intermediate coil support shall be provided on coils with a finned length of more than 62 inches; two intermediate supports above 100 inches long. Casing channels shall be free-draining, without depressions to collect moisture and contaminants or block fin area.

WATER

Water coil capacities and pressure drops – shall be certified in accordance with ARI Standard 410. All coils must be circuited to operate at design loading with water velocity within the ARI range of certified rating conditions.

Headers – shall be of heavy seamless copper tubing, silver-brazed to tubes. Connections shall be of red brass, with male pipe threads, silver-brazed to headers. Provide a 1/4" FPT, plugged vent or drain tap on each connection. All coils must have same-end connections, regardless of number of rows deep.

Circuiting – Coils shall be circuited, and have connections arranged, for counterflow of air and water with supply on bottom and return on top of coil headers. Coil circuiting shall provide for design water velocity in tubes without exceeding total water pressure drops in schedule.

Test Parameters – Completed coil, including headers, connections, and return bends, shall be tested with 325 pounds compressed air under water. Coils shall be designed for operation at 250 PSIG design working pressure and up to 300°F.

HIGH PRESSURE APPLICATION

CONSTRUCTION AND RATINGS

CLASSIFICATION	TUBE	HEADERS		O.P. TEMPERATURE (°F)			
		MATERIAL	WALL THICKNESS	DESIGN WORKING PRESSURE (PSIG)			
				0-100	200	300	400
STANDARD	5/8 x 0.020 or 1/2 x 0.016	Copper	Standard	295	255	250	130
MEDIUM PRESSURE	5/8 x 0.025 or 1/2 x 0.020	Red Brass*	Standard	425	340	330	220
HIGH PRESSURE	5/8 x 0.035 or 1/2 x 0.032	Red Brass*	Extra Heavy	600	480	470	200

* SQ Required for medium and high pressure

Water Coils – Chilled Water

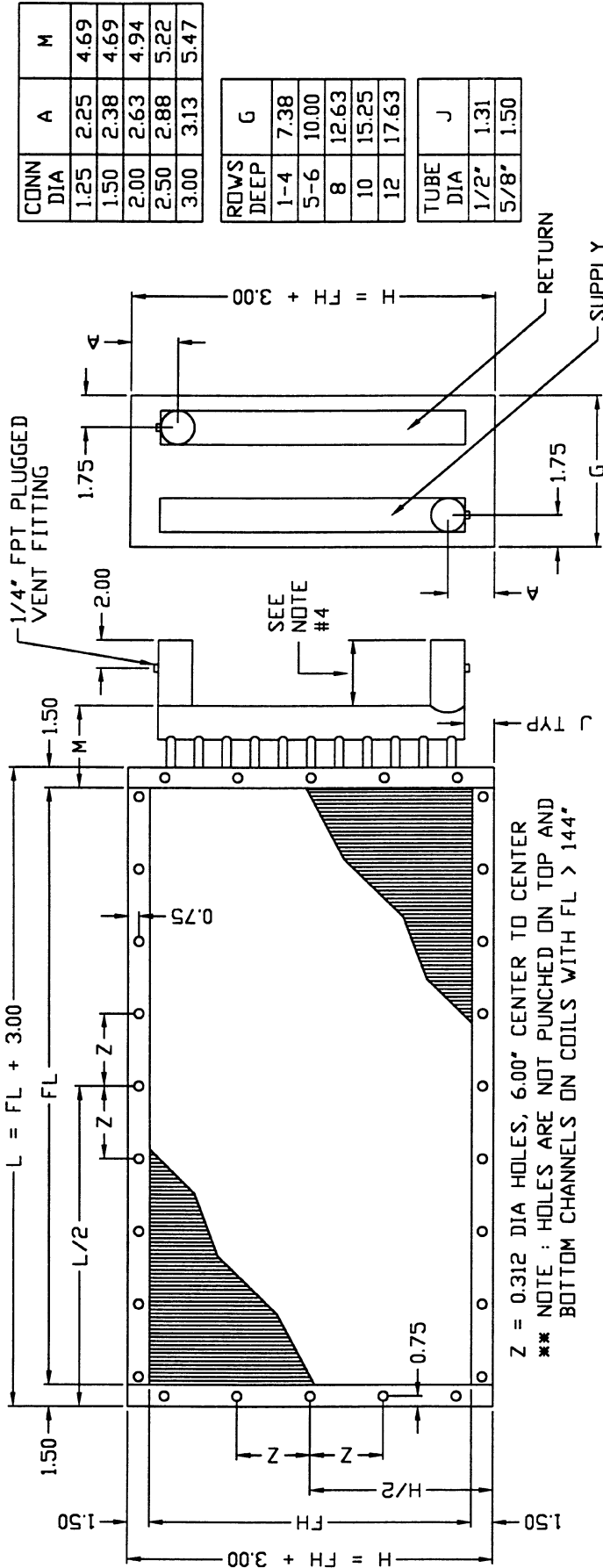

CONN DIA	A	M
1.25	2.25	4.69
1.50	2.38	4.69
2.00	2.63	4.94
2.50	2.88	5.22
3.00	3.13	5.47

ROWS DEEP	G
1-4	7.38
5-6	10.00
8	12.63
10	15.25
12	17.63

TUBE DIA	J
1/2"	1.31
5/8"	1.50

AIRFLOW

LEFT HAND SHOWN
RIGHT HAND OPPOSITE

NOTES

- STANDARD COILS ARE PROVIDED ON -
A. 1/2" TUBE DIA - 6 THRU 38 TUBES HIGH
B. 5/8" TUBE DIA - 6 THRU 32 TUBES HIGH
- RETURN BENDS PROJECT 7/8" (MAX) BEYOND CASING FLANGE.
- DIMENSIONS - INCHES ± 1/4".
- CONNECTOR LENGTHS ARE MEASURED FROM THE OUTSIDE OF THE HEADER TO THE END OF THE CONNECTOR.

		TUBES HIGH																											
		6	8	10	12	14	16	18	20	22	24	26	28	30	32	34	36	38											
1/2" TUBE DIA	FH	7.50	10.00	12.50	15.00	17.50	20.00	22.50	25.00	27.50	30.00	32.50	35.00	37.50	40.00	42.50	45.00	47.50											
5/8" TUBE DIA	FH	9.25	12.25	15.25	18.25	21.25	24.25	27.25	30.25	33.25	36.25	39.25	42.25	45.25	48.25	N/A	N/A	N/A	N/A										

379-21161-005

LD03703

FIG. 1 – DIAGRAM, WATER COILS

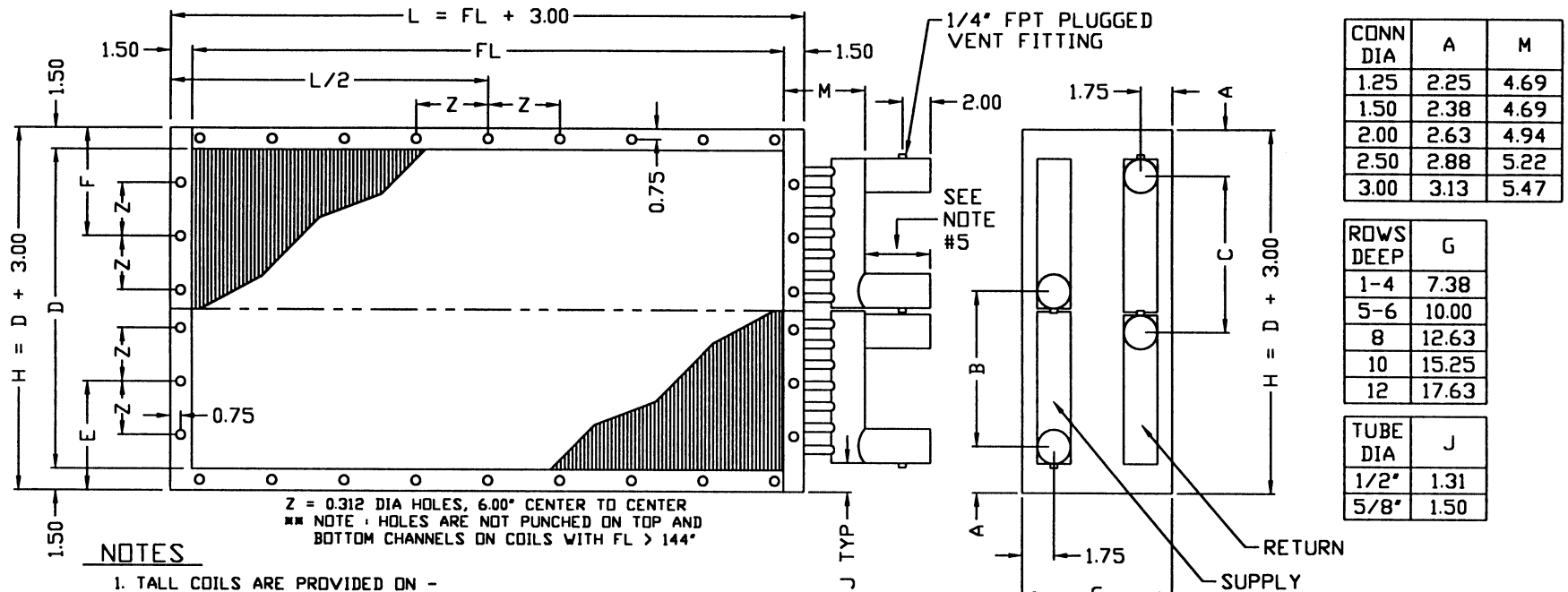

Z = 0.312 DIA HOLES, 6.00" CENTER TO CENTER
 ** NOTE : HOLES ARE NOT PUNCHED ON TOP AND BOTTOM CHANNELS ON COILS WITH FL > 144"

NOTES

1. TALL COILS ARE PROVIDED ON -
 - A. 1/2" TUBE DIA - 40 THRU 76 TUBES HIGH
 - B. 5/8" TUBE DIA - 34 THRU 64 TUBES HIGH
2. TALL COILS CONSIST OF TWO FINPACKS WITH A HEADER FOR EACH FINPACK. THE FINPACKS WILL BE SPLIT AS FOLLOWS -
 - A. IF THE HALF OF THE TUBE HEIGHT IS AN EVEN NUMBER, THEN BOTH FINPACKS ARE THE SAME NUMBER OF TUBES HIGH.
 - B. IF THE HALF OF THE TUBE HEIGHT IS AN ODD NUMBER, THEN THE BOTTOM FINPACK TUBE HEIGHT IS ONE MORE THAN HALF AND THE TOP FINPACK TUBE HEIGHT IS ONE LESS THAN HALF.
3. RETURN BENDS PROJECT 7/8" (MAX) BEYOND CASING FLANGE.
4. DIMENSIONS - INCHES ± 1/4"
5. CONNECTOR LENGTHS ARE MEASURED FROM THE OUTSIDE OF THE HEADER TO THE END OF THE CONNECTOR.

CONN DIA	A	M
1.25	2.25	4.69
1.50	2.38	4.69
2.00	2.63	4.94
2.50	2.88	5.22
3.00	3.13	5.47

ROWS DEEP	G
1-4	7.38
5-6	10.00
8	12.63
10	15.25
12	17.63

TUBE DIA	J
1/2"	1.31
5/8"	1.50

AIRFLOW LEFT HAND SHOWN
 RIGHT HAND OPPOSITE

		TUBES HIGH											TUBES HIGH										
		34	36	38	40	42	44	46	48	50	52	54	56	58	60	62	64	66	68	70	72	74	76
1/2" TUBE DIA	B	N/A	N/A	N/A	25.50	28.00	28.00	30.50	30.50	33.00	33.00	35.50	35.50	38.00	38.00	40.50	40.50	43.00	43.00	45.50	45.50	48.00	48.00
	C	N/A	N/A	N/A	25.50	25.50	28.00	28.00	30.50	30.50	33.00	33.00	35.50	35.50	38.00	38.00	40.50	40.50	43.00	43.00	45.50	45.50	48.00
	D	N/A	N/A	N/A	50.50	53.00	55.50	58.00	60.50	63.00	65.50	68.00	70.50	73.00	75.50	78.00	80.50	83.00	85.50	88.00	90.50	93.00	95.50
	FH	N/A	N/A	N/A	50.00	52.50	55.00	57.50	60.00	62.50	65.00	67.50	70.00	72.50	75.00	77.50	80.00	82.50	85.00	87.50	90.00	92.50	95.00
	E	N/A	N/A	N/A	14.13	15.38	15.38	16.63	16.63	17.88	17.88	19.13	19.13	20.38	20.38	21.63	21.63	22.88	22.88	24.13	24.13	25.38	25.38
	F	N/A	N/A	N/A	14.13	14.13	15.38	15.38	16.63	16.63	17.88	17.88	19.13	19.13	20.38	20.38	21.63	21.63	22.88	22.88	24.13	24.13	25.38
5/8" TUBE DIA	B	27.25	27.25	30.25	30.25	33.25	33.25	36.25	36.25	39.25	39.25	42.25	42.25	45.25	45.25	48.25	48.25	N/A	N/A	N/A	N/A	N/A	N/A
	C	24.25	27.25	27.25	30.25	30.25	33.25	33.25	36.25	36.25	39.25	39.25	42.25	42.25	45.25	45.25	48.25	48.25	N/A	N/A	N/A	N/A	N/A
	D	51.50	54.50	57.50	60.50	63.50	66.50	69.50	72.50	75.50	78.50	81.50	84.50	87.50	90.50	93.50	96.50	N/A	N/A	N/A	N/A	N/A	N/A
	FH	51.50	54.50	57.50	60.50	63.50	66.50	69.50	72.50	75.50	78.50	81.50	84.50	87.50	90.50	93.50	96.50	N/A	N/A	N/A	N/A	N/A	N/A
	E	15.13	15.13	16.63	16.63	18.13	18.13	19.63	19.63	21.13	21.13	22.63	22.63	24.13	24.13	25.63	25.63	N/A	N/A	N/A	N/A	N/A	N/A
	F	13.63	15.13	15.13	16.63	16.63	18.13	18.13	19.63	19.63	21.13	21.13	22.63	22.63	24.13	24.13	25.63	N/A	N/A	N/A	N/A	N/A	N/A

7 FIG. 1 (CONT'D) - DIAGRAM, WATER COILS

379-21161-006

LD03704

Direct Expansion Coils

MECHANICAL SPECIFICATIONS

Primary Surface – 1/2" & 5/8" OD round seamless copper tubes arranged in a staggered tube pattern in respect to air flow.

Secondary Surface – TURBOFIN, with directional guide channels to ensure maximum air to fin contact, is constructed of aluminum or copper. Fin edges are die-formed and work hardened to initiate immediate turbulence and to strengthen the fin edge. Tubes are mechanically expanded providing the optimum tube-to-fin bond.

Casing – The top and bottom channels and end sheets are constructed of heavy galvanized steel. Mounting holes, evenly spaced around the perimeter of the casing, are provided for attaching to ductwork or plenum chamber. One center coil support is furnished with coils having a 60 to 90 inch fin length. Two coil supports are furnished with coils having a fin length over 90 inches.

Return Bends – Constructed of 5/8" OD round seamless copper tubing with a uniform flow area throughout the radius of the bend, silver brazed to tubes.

Headers and Distributors – Constructed of heavy seamless copper tubing or brass, silver brazed to tubes. The distributor is of the Venturi type providing even distribution of refrigerant. All piping connections are of the male solder type, extended so field connection can be made outside the unit casing.

Dehydrated and Sealed – Coil assembly is dehydrated to minimal moisture content and sealed under pressure for shipment.

APPLICATION RECOMMENDATIONS

1. Direct expansion coils should be installed with tubes reasonably level.
2. Each coil must be installed with suction header nearest to entering air face of coil, with suction connection at lower end. Orientation of refrigerant distributor is not critical but feed tubes must not be kinked or bent in a nonuniform manner.
3. An individual expansion device must be provided for each section of coil. If suctions are paralleled as in a stacked coil bank, piping arrangement must avoid liquid from one suction line reaching another (affecting expansion valve operation).
4. Thermostatic expansion valves should be equipped with external equalizers, field connected to suction

line. Size valve in accordance with manufacturer's recommendation, allowing approximately 35 psi pressure drop through coil and distributor at full load. Do not oversize valve, but design balances of system to assure adequate valve inlet pressure for required capacity at below peak conditions. Follow valve manufacturer's instructions on location of thermostatic bulb. Proper expansion valve operation is necessary for full coil capacity.

5. Continued operation at below freezing suction temperature may cause frosting at coil. Therefore, design at below 32°F suction is not recommended. Even if full load operation is selected for a "safe" temperature, system analysis is required to check for lower suction temperature at light load conditions. Suction-pressure-controlled hot gas bypass valves are available by various control manufacturers to maintain an adequate minimum temperature.
6. The venturi type distributor furnished with YORK DX coils is suitable for field application of a hot gas bypass valve. Connection may be made through a tee installed in the field between the expansion valve and the distributor. Balance of system and control adjustments must ensure compressor cooling and avoid excessive compressor cycling.
7. YORK DX coils are suitable for use with other refrigerants generally similar to R-22. Refer to factory for specific applications.
8. Coils used in dehumidifying duty and banked two or more high must have a drain trough installed on each upper coil. Tubing should be provided to drain the upper pans into the main drain pan. Lower coils should have a drain pan that extends beyond the casing and headers (a minimum of 10 inches beyond the leaving face of the coil). The drain pan must be elevated to provide free drainage of condensate and to provide ample space for installation of a trap in the drain line to overcome pressure in the coil casing.
9. Coils will meet performance ratings only if the air-flow is uniform over the face of the coil. High velocity spots may cause moisture carry-over. Low velocity areas will not deliver the publishing rating. Duct and casing design must provide uniform face velocity. The entering side must produce a smooth transition from any high velocity effects. Fans blowing through the coil must have a long transition or baffling (as in typical multi-zone units). The leaving side of the coil is less critical, but no area may be blocked by the casing or other elements (e.g. DWDI fans with scroll near the leaving coil face.)

GUIDE SPECIFICATIONS

General

Contractor shall furnish and install Direct Expansion coils, manufactured by YORK to meet the performance requirements set forth in the schedule. Coils shall be available for R-22.

Certification

All coils shall have performance certified in accordance with ARI Standard 410.

Tubes

All coils shall have 1/2" & 5/8" OD seamless copper tube arranged in a staggered pattern perpendicular to the air flow. The copper tubes shall be firmly bonded to the fins by mechanical expansion.

Headers and Distributors

All headers shall be of heavy seamless copper tubing or brass, as dictated by the schedule, and shall be silver brazed to the tubes. The refrigerant distributor shall be of the venturi type for even distribution of refrigerant and low-pressure drop, sized for the required duty and silver brazed to the distributor tubes. All piping connections shall be of a male sweat type. The distributor tubes shall be of 1/4" or 5/16" round seamless copper sized for the required duty and of equal length for maximum distributor efficiency.

Fins

Aluminum fins shall be available in either .006" (or .010") thickness and copper fins shall be available in .006" thickness. All shall have a die-formed corrugation with guide channels to create a turbulent wiping action behind the tubes and minimize moisture carry-over. Fins

shall have fully drawn collars for accurate spacing and to maximize fin tube contact. Fins shall be firmly bonded by mechanical expansion to increase heat transfer and ensure reliability. Fins shall be continuous across entire width of the coil up to 48-1/4".

Casing

The casing shall be a full channel, die formed, mill galvanized steel and provide ample shipping and stacking support for the fin bundle. Tube sheets shall have extruded collars for tube support and to prevent damage due to expansion and contraction of the fin bundle. Intermediate coil casing channel supports shall be provided on coils with a fin length greater than 62"; two supports above 100". Casing channels shall be free draining, without depressions to prevent moisture and contaminants collection.

Face Splits

Face splints shall be available when single coil total MBH exceeds 500 MBH or for multiple compressor applications. The minimum split section shall never be less than 6 tubes high. Coil face splits should be of equal number of tubes to provide equal refrigerant load splits.

Row Control

Row control shall be available by selecting two or more coils positioned in series.

Testing and Working Pressures

All coils, including headers, return bends, and distributors, shall be designed to conform to the ANSI B9.1 (Safety Code for Mechanical Refrigeration) when operating with a refrigerant pressure not exceeding 325 PSIG and shall be tested with 325 PSIG compressed air under water.

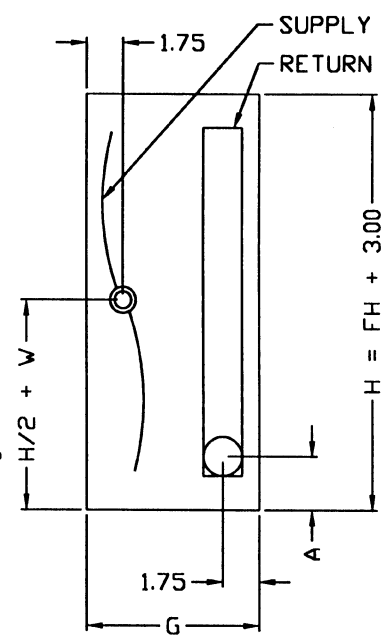
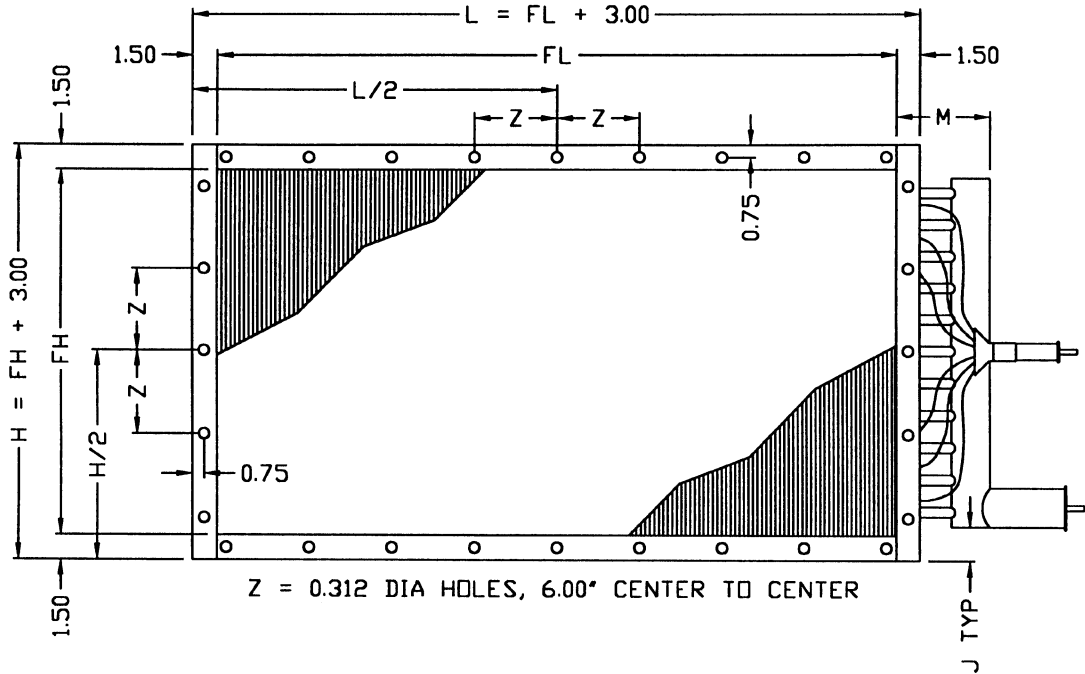

CONN DIA	A	M
1.25	2.25	4.69
1.50	2.38	4.69
2.00	2.63	4.94
2.50	2.88	5.22
3.00	3.13	5.47

ROWS DEEP	G
1-4	7.38
5-6	10.00
8	12.63
10	15.25
12	17.63

TUBE DIA	J
1/2"	1.31
5/8"	1.50

TUBE DIA	ROWS DEEP	W
1/2"	1,2,4,5,6,10&12	-0.312
	3 & 8	0.312
5/8"	1,2,4,5,6,10&12	-0.375
	3 & 8	0.375

NOTES

- STANDARD COILS ARE PROVIDED ON -
 A. 1/2" TUBE DIA - 6 THRU 38 TUBES HIGH
 B. 5/8" TUBE DIA - 6 THRU 32 TUBES HIGH
- RETURN BENDS PROJECT 7/8" (MAX) BEYOND CASING FLANGE.
- DIMENSIONS - INCHES ± 1/4"

AIRFLOW

LEFT HAND SHOWN
 RIGHT HAND OPPOSITE

		TUBES HIGH																
		6	8	10	12	14	16	18	20	22	24	26	28	30	32	34	36	38
1/2" TUBE DIA	FH	7.50	10.00	12.50	15.00	17.50	20.00	22.50	25.00	27.50	30.00	32.50	35.00	37.50	40.00	42.50	45.00	47.50
5/8" TUBE DIA	FH	9.25	12.25	15.25	18.25	21.25	24.25	27.25	30.25	33.25	36.25	39.25	42.25	45.25	48.25	N/A	N/A	N/A

379-21161-008

FIG. 2 – DIAGRAM, DIRECT EXPANSION COILS

LD03705

Piping Arrangements

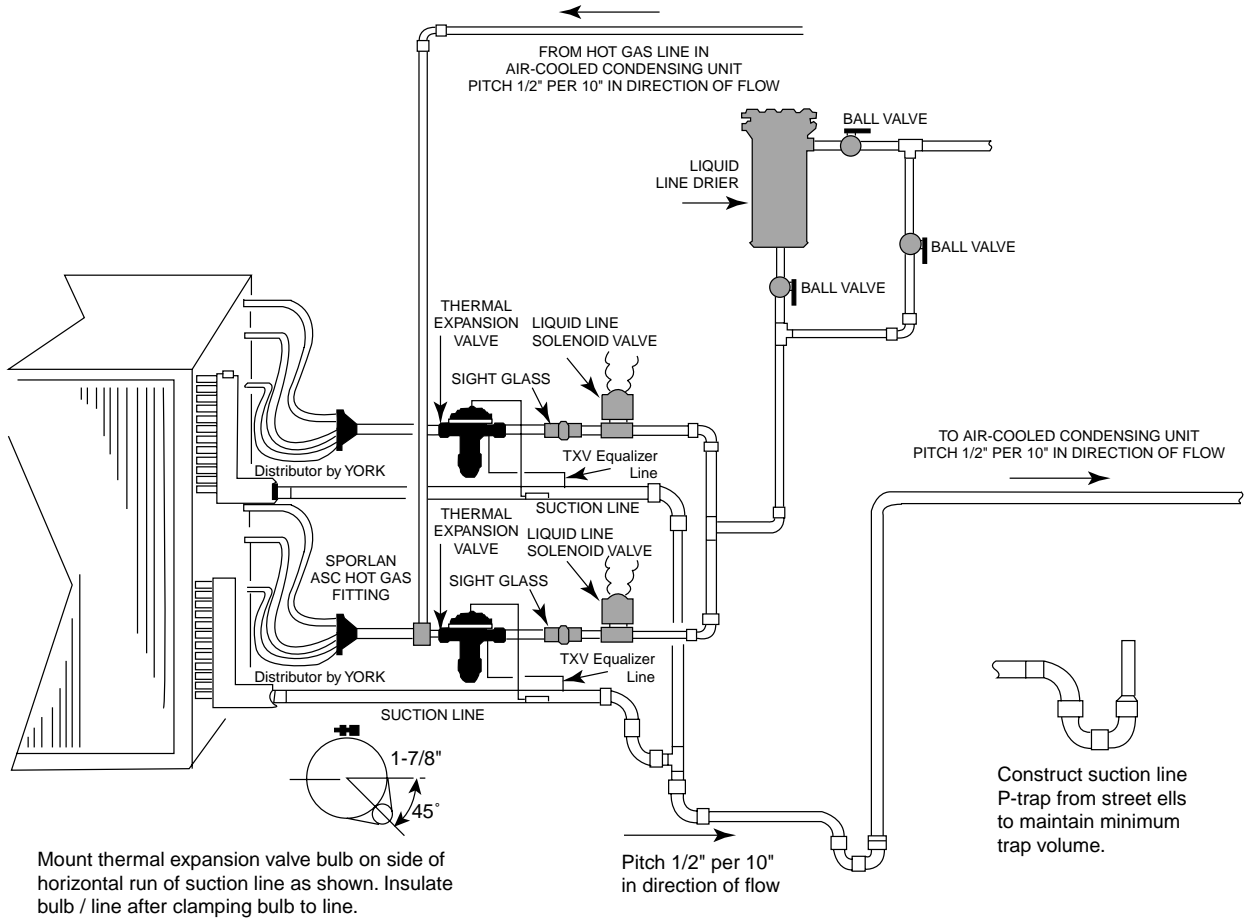
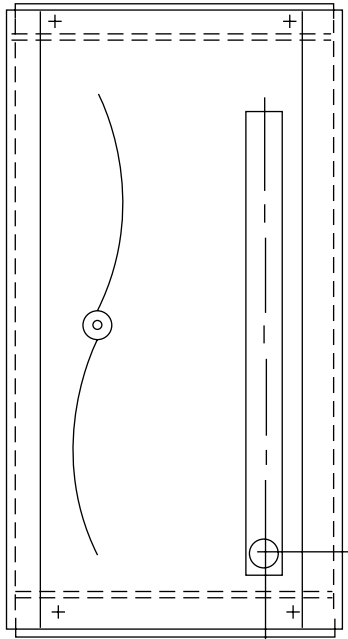

FIG. 3 – PIPING ARRANGEMENTS

LD05171



LD04884

FULL FACE
Typically used on systems less than ten tons.

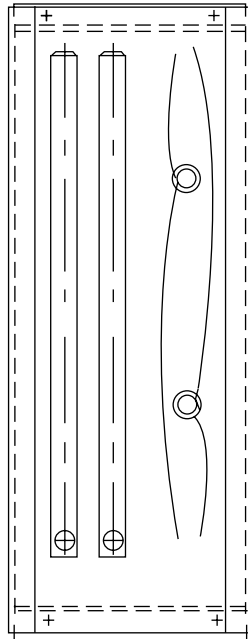

LD04885

INTERLACED
Typically used on large systems with four or more unloading steps.

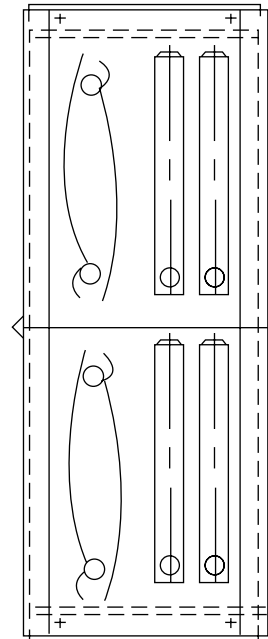

LD04886

INTERLACED FACE SPLIT
Used on systems larger than 10 tons with no more than two refrigerant circuits and multiple unloading steps.

Steam Coils

MECHANICAL SPECIFICATIONS

Primary Surface – 1 inch round seamless copper tubes with 5/8" OD interior steam distributing tubes - one row deep. Distance positioned on a 3" center.

Secondary Surface – Constructed of aluminum. Fin edges are die-formed and work-hardened to initiate immediate turbulence and to strengthen the fin edge. Tubes are mechanically expanded providing the optimum tube-to-fin bond.

Casing – The top and bottom channels and end sheets are constructed of heavy gauge galvanized steel. The coil is pitched in the casing from the supply to the return end - in both directions to provide condensate drainage. Mounting holes, evenly spaced around the perimeter of the casing, are provided for attaching to ductwork or plenum chamber. Center coil supports are furnished with coils having a 63" fin length. Two coil supports are furnished with coils having a 62" to 100" fin length.

Headers – Inlet and outlet headers are constructed of hard-drawn seamless copper tubing with male pipe threaded connections of red brass, silver brazed.

APPLICATION RECOMMENDATIONS

Piping and Supports

1. Piping must be supported independently of the coil. In addition, swing joints must be used to avoid placing expansion stresses on coil headers. Direct piping hook-ups can cause damage to the coil.
2. Do not bush or reduce pipe size at coil return. Use full return size pipe to bottom of dirt pocket. Supply may be reduced at coil connection if desired.
3. Install coil casing level with return down. YORK coils are pitched in the casing for either horizontal or vertical air flow, thus ensuring condensate drainage.
4. Coils must be sufficiently elevated to allow a 12 inch minimum drop to the trap. A greater drop than 12 inches is required for freeze protection. The return line should be located below the trap.
5. Casing is rigidly constructed and is structurally adequate for stacking coils by bolt fastening of end sheets.

Control of Steam Supply

1. Continuous steam supply ensures long coil life and minimizes trapping, venting and freezing problems. Coil output can be varied by controlling air flow.

2. Rapid cycling of the modulating steam supply or frequent on-off steam control results in repeated thermal and piping stresses which will shorten coil life. These can normally be avoided by following recommendations of the control manufacturer and by proper adjustment and maintenance of controls. Modulating steam control valves must not be oversized – select carefully. Substantial supply pressure variation will require the installation of a pressure reducing valve ahead of the automatic valve.
3. Light load operating with modulated steam supply is improved by a vacuum breaker check valve. An open relief line to the atmosphere from the return line near the coil is desirable, except on vacuum systems.
4. With modulated steam supply, it is not practical to lift condensate to an overhead return. Locate coil well above return or provide condensate unit or boiler return trap below coil.
5. Individual control valves are required on coils installed in series. When a modulating steam valve supplied two or more coils in paralleled air flow, piping must provide for uniform steam distribution.

Steam Traps

1. Float and thermostatic (F&T) traps are recommended for all low or medium pressure applications. Use thermostatic traps only for air venting, small booster coils or for outdoor applications where an F&T trap might be subject to freezing.
2. Size traps in accordance with manufacturers' recommendations (usually several times steady-state steam flow). Use actual operating conditions (coil pressure vs. return pressure) for trap selection.
3. It is preferable to provide an individual trap for each coil but a single trap may be used for coils operating in parallel air flow. Coils in series air flow must have individual traps.
4. Locate the trap at least 12 inches below coil return connection. Do not attempt to lift condensate with modulated steam supply.

Freezing Conditions

1. Outside air and return air must be thoroughly mixed before entering the coil. Freezing air entering only part of the coil creates a greater potential for freezing than uniform distribution.
2. Coil in series air flow must have individual control with space between coils for sensing devices if required.

Water Treatment

Any copper tube coils may be attacked by acid condensate. Boiler water treatment practice should include consideration of CO₂ removal.

GUIDE SPECIFICATIONS

General

Contractor shall furnish and install, where indicated on the plans, YORK steam coils as described in the following specifications.

Certification

Steam coil capacities and pressure drops shall be certified in accordance with ARI Standard 410.

Tubes

All coils shall have 1" OD condensate tube with a concentric 5/8" OD steam distributing tube. Tubes shall be seamless copper type, mandrel expanded to form fin bond and provide burnished, work-hardened interior surface.

Headers

All headers shall be of heavy seamless copper tubing, silver brazed to tubes. Connections shall be of red brass, with male pipe threads, silver brazed to headers.

Fins

Aluminum fins shall have a die-formed corrugation with guide channels to create a turbulent wiping action behind the tubes and minimize moisture carry-over. Fins shall have fully drawn collars for accurate spacing and to maximize fin tube contact. Fins shall be firmly bonded by mechanical expansion to increase heat transfer and ensure reliability.

Casing

The casing shall be of full channel, die formed mill galvanized steel and provide ample shipping and stacking support for the fin bundle. Tube sheets shall have extruded collars for tube support and to prevent damage due to expansion and contraction of the fin bundle. Intermediate coil casing channel supports shall be provided on coils with a fin length greater than 62". The core shall be of a pitched construction in both directions providing condensate drainage in either horizontal or vertical air-flow applications.

Test and Working Pressures

All coils, including headers, connections and return bends shall be tested with 325 pounds compressed air under water. Coils shall be designed to operate at 50 PSIG. Pressure, and a corresponding saturated steam temperature of 298°F.

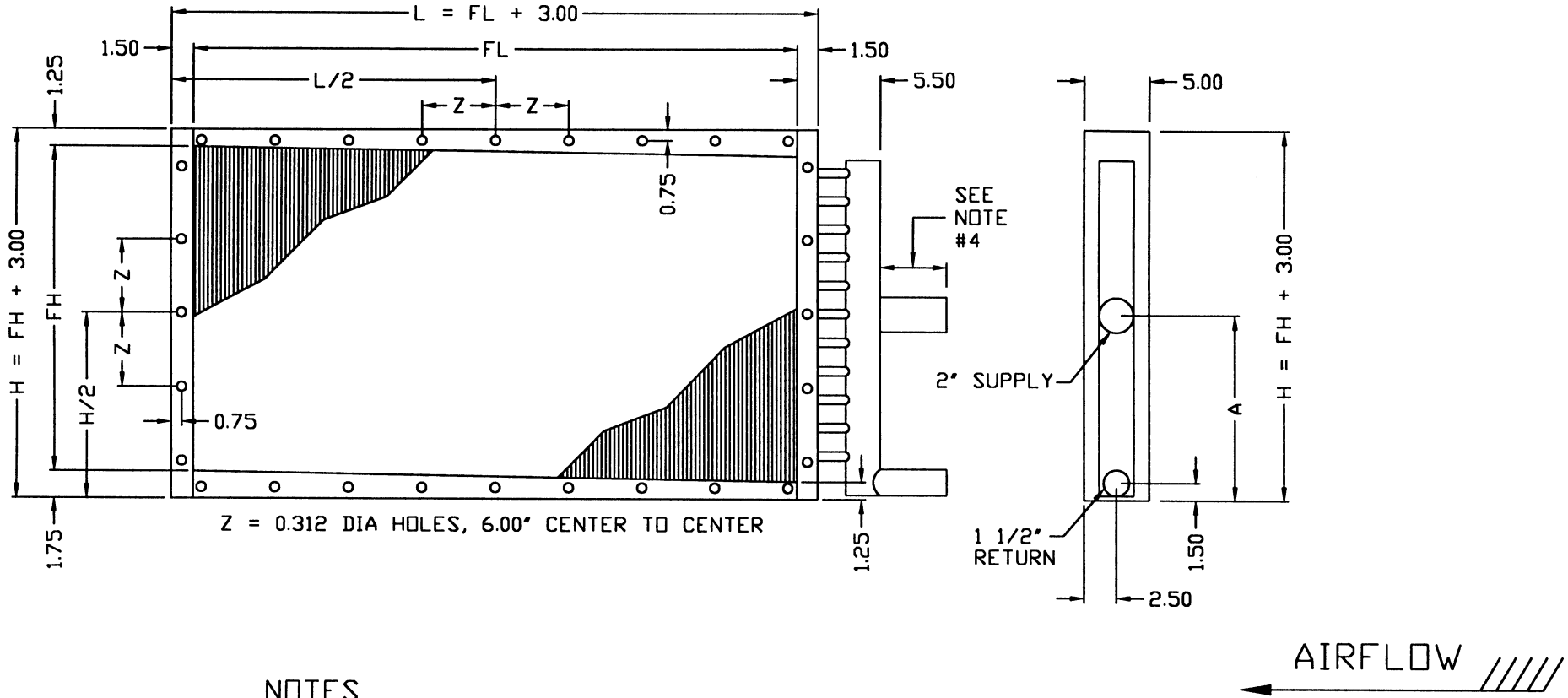

NOTES

1. STANDARD COILS ARE FROM 3 THRU 16 TUBES HIGH.
2. DIMENSIONS - INCHES $\pm 1/4$ ".
3. CONNECTOR LENGTHS ARE MEASURED FROM THE OUTSIDE OF THE HEADER TO THE END OF THE CONNECTOR.
4. THE END VIEW IS THE SAME FOR RIGHT AND LEFT HAND.
5. COIL SHOWN IS FOR HORIZONTAL AIRFLOW.

	TUBES HIGH													
	3	4	5	6	7	8	9	10	11	12	13	14	15	16
FH	9.00	12.00	15.00	18.00	21.00	24.00	27.00	30.00	33.00	36.00	39.00	42.00	45.00	48.00
A	6.00	7.50	9.00	10.50	12.00	13.50	15.00	16.50	18.00	19.50	21.00	22.50	24.00	25.50

379-21505-000

FIG. 4 - DIAGRAM, STEAM COILS

LD03712

PIPING ARRANGEMENTS

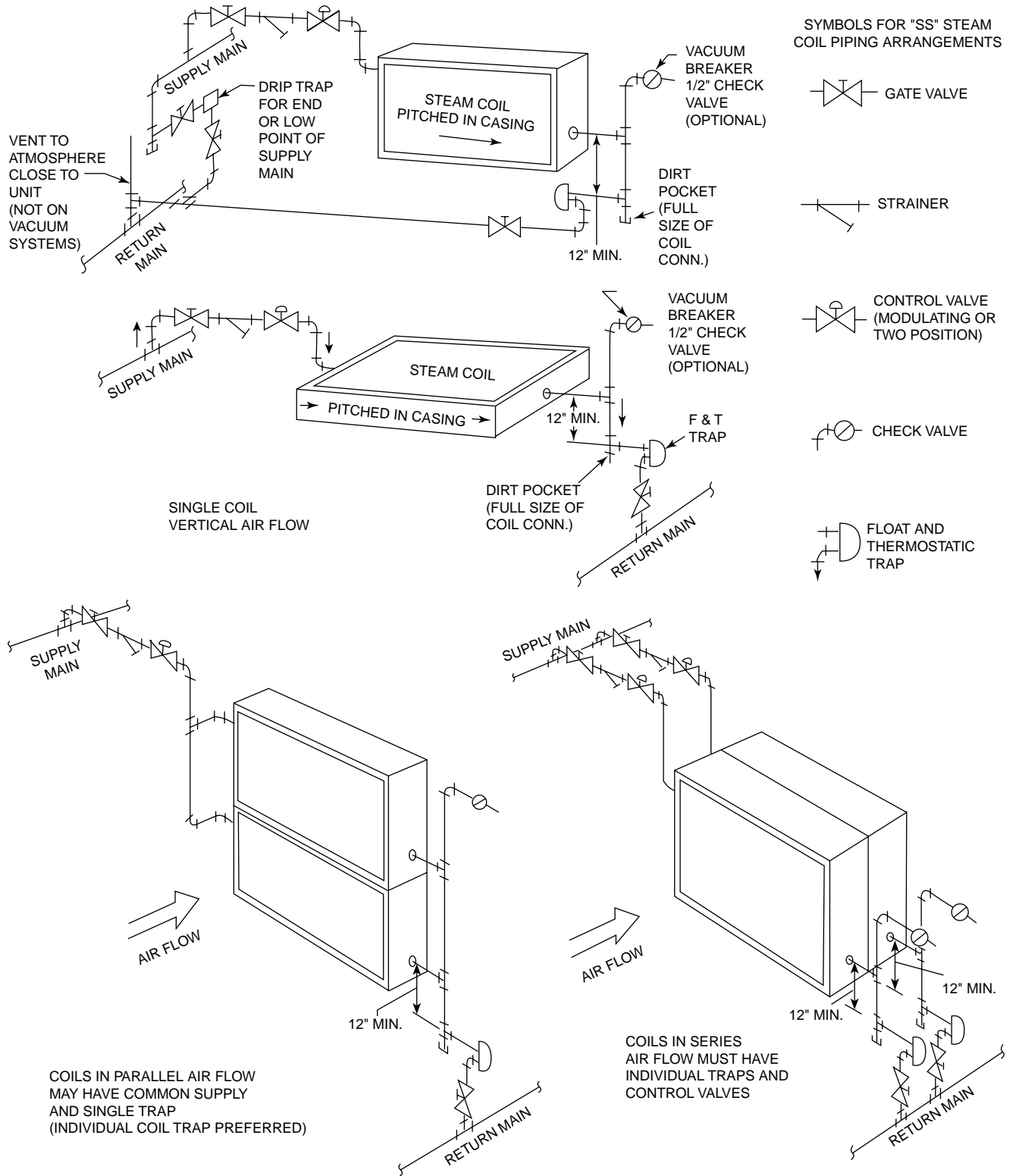

FIG. 5 – PIPING ARRANGEMENTS

Booster Coils

MECHANICAL SPECIFICATIONS

Tube Core – is 5/8" OD x 0.020" wall straight seamless copper tubing with brazed return bends – no hairpins. The tubes are mechanically expanded into the fins to form a strong, permanent, high-pressure metal-to-metal contact for all heating duty applications.

Secondary Surface – consists of die-formed aluminum fins that are accurately shaped to provide a well-mixed airflow pattern for maximum heat transfer at a minimum air side pressure loss. Each core tube hole is accurately sized with full fin collars that automatically and accurately space the adjacent fin and completely cover the core tubing between each fin. The fin spacing offering was selected to a wide duty range with the minimum row depth and air friction.

Connectors – are 1/2" FPT copper for all one-circuit coils and 3/4" FPT copper for all two-circuit coils. Supply connection is at the bottom and the return is at the top for all coils. The connectors are located near the tube sheet to facilitate installation in tight locations.

Circuiting – on all coils is of drainable design, having no pockets in any circuit, thus facilitating complete gravity drain when the coil is erected in the recommended position. No mechanical devices are used to increase water turbulence that would impair in any way whatsoever the water/condensate drainability design of these coils. The multi-circuit style offering obsoletes the use of such internal tube turbulators. All coil circuits are of equal length.

Return Bends – are accurately formed to sufficiently large radii for smooth return media flow with minimum pressure losses. The minimum metal wall thickness at any point after forming of the return bends is never less than the actual measured wall thickness of the expanded coil core tubing.

Casings – fabricated from galvanized steel. The zinc-coated casings are of a unique design that results in the ultimate in simplicity for attachment to ductwork.

The casing becomes part of the ductwork by using common drive clips and "S" clips that are employed in the sheet metal trade to connect the industry standard slip and drive receiving flanges to the duct work.

Continuous Duty – design of the coils on hot-water duty are suitable for operation at 250 PSIG and 300°F maximum. All coils are factory leak tested at 315 PSIG air pressure under water.

GUIDE SPECIFICATIONS

Certified in accordance with the ARI Forced-Circulation Air-Cooling and Air-Heating Coils Certification Program, which is based on ARI Standard 410.

Furnish and install, where indicated on the plans, YORK Booster Coils as described in the following specifications.

Primary Surface – shall be 5/8" OD x 0.020" tube constructed of seamless copper. The tubing shall be straight tube construction - no hair pin bends. Tubes shall be permanent. Return bends shall be die-formed and brazed to tubes.

Extended surface – shall be .006" aluminum plate fins accurately sized and completely die-formed to cause an air flow pattern for maximum heat transfer at the specified air side pressure loss. The tube holes are to be accurately sized with full collars that automatically and accurately space the adjacent fin and completely cover the tubing between each fin.

Casings – Coil casings are to be fabricated from 20 gauge galvanized steel. The casing shall be furnished with a slip & drive receiving flange on each side. Both top and bottom coil flange sheets are to be firmly affixed onto the coil. Tolerance shall be + or – 1/4".

TEST PARAMETERS

Hot Water Coils – To be suitable for 250 PSIG and 300°F maximum. Coils to be tested at 325 PSIG air pressure under water.

BOOSTER COILS NOMENCLATURE

<u>8</u>	<u>12</u>	<u>12</u>	<u>12</u>	<u>10</u>	<u>1</u>	<u>075</u>	<u>F</u>	<u>S</u>
Coil ID	Fin Height	Fin Length	Rows Deep	FPI	# of Circuits	Conn. Dia.	Conn. Type	Slip & Drive

TABLE 1 – BOOSTER COIL FACE AREA (SQ. FT.)

FIN HEIGHT (INCHES)	TUBE FACE	FINNED LENGTH (INCHES)										
		6"	9"	12"	15"	18"	21"	24"	27"	30"	33"	36"
6"	4	0.25	0.38	0.50	0.62	0.75	0.87	1.00	1.12	1.25	1.37	1.50
9"	6	—	0.56	0.75	0.93	1.12	1.31	1.50	1.68	1.87	2.06	2.25
12"	8	—	—	1.00	1.25	1.50	1.75	2.00	2.25	2.50	2.75	3.00
15"	10	—	—	—	1.56	1.87	2.18	2.50	2.81	3.12	3.43	3.75
18"	12	—	—	—	—	2.25	2.63	3.00	3.38	3.75	4.13	4.50

TABLE 2 – TUBES PER CIRCUIT

CIRCUIT TYPE	ROWS DEEP	TUBE FACE				
		4	6	8	10	12
1 Circuit	1	4	6	8	10	12
	2	8	12	16	20	24
2 Circuits	2	4	6	8	10	12

A = Fin Length
B = Fin Height

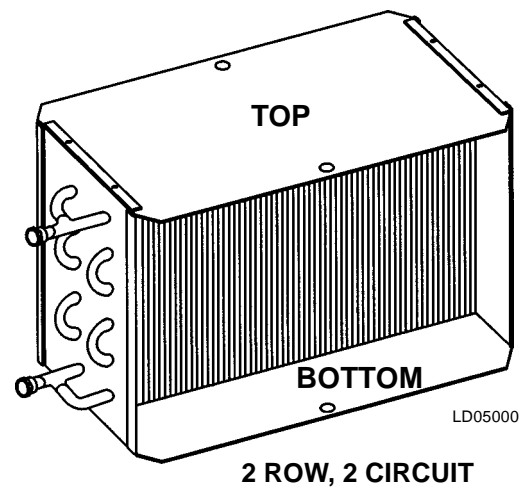
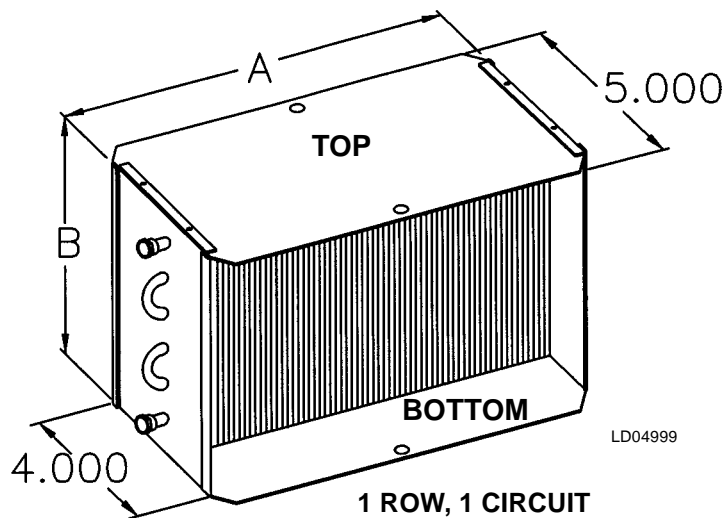
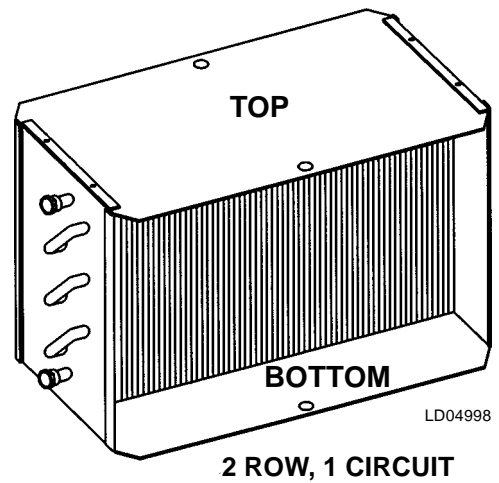

FIG. 6 – DIAGRAM, BOOSTER COIL



STEAM, WATER AND DX COIL NOMENCLATURE

(BOOSTER COIL NOMENCLATURE ON PAGE 16)

