

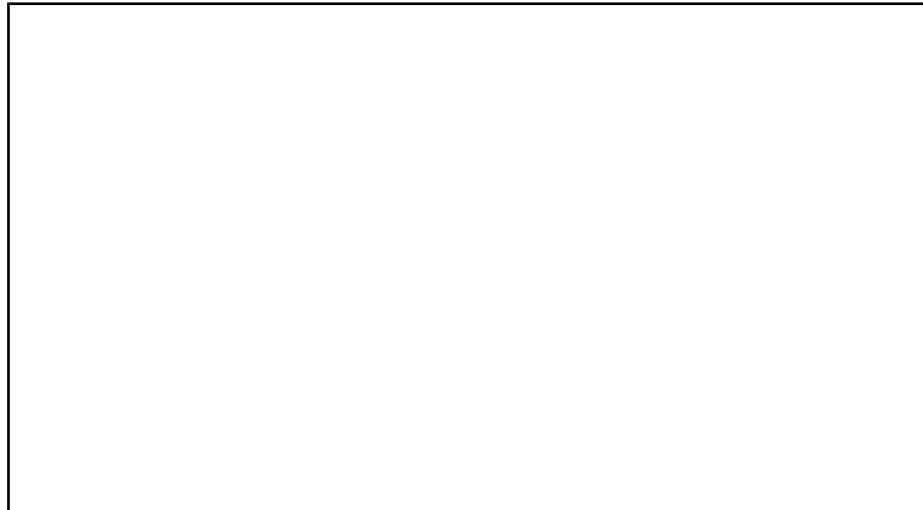

30GT-41SB

**30GT040-110
FLOTRONIC™
AIR-COOLED CHILLERS**

- PERFORMANCE DATA**
- CERTIFIED DIMENSION PRINT**
- FIELD WIRING DIAGRAM**



© 1998 Carrier Corporation • Syracuse, New York 13221

Date:	Supersedes:	30GT040-110 FLOTRONIC™ AIR-COOLED CHILLERS	30GT	Rev.: 41SB
-------	-------------	---	------	---------------

JOB NAME:	LOCATION:
-----------	-----------

BUYER:	BUYER P.O. #	CARRIER #
--------	--------------	-----------

UNIT NUMBER:	MODEL NUMBER:
--------------	---------------

PERFORMANCE DATA CERTIFIED BY:	DATE:
--------------------------------	-------

DESCRIPTION

These air-cooled package chillers are factory piped, wired and charged with Refrigerant 22. Rugged, weatherproof construction and compact design make them ideal for rooftop or ground level installation. Upward discharge airflow minimizes directional sound and dissipates heat away from surrounding areas.

FEATURES

Standard one-year warranty.

Multiple reciprocating serviceable-hermetic compressors mounted on spring isolated rails. Automatically reversible oil pump, thermal overload protection, suction and discharge service valves.

Calibrated, ambient compensated magnetic-trip circuit breakers with manual reset provide single-phase and phase-reversal protection.

Insert-type 180-watt crankcase heaters.

High- and low-pressure safety switches.

Dual refrigerant circuits. Each refrigerant circuit contains: Hot gas muffler for each compressor, excessive pressure relief device, liquid line shut-off valve, replaceable-core filter drier, moisture indicating sight glass, loss of oil pressure protection.

Electronic expansion valve in each refrigeration circuit.

Automatic lead-lag feature automatically alternates the lead circuits to ensure even cycles and run time.

Single point main power connection.

Compressor timed pumpdown cycle at start-up and stopping of each refrigeration circuit cooling cycle.

Unit capable of starting with up to 95° F water entering the cooler, with 125° F outdoor air.

Units equipped with electronic expansion valves are capable of starting and operating down to 0° F outside-air temperatures with wind baffles installed. Below 0° F outside-air temperature, the unit must be modified for low-ambient operation. Below 32° F, unit must be equipped with wind baffles.

Low water flow detection provided by internal control devices.

Control capacity based on leaving-water temperature, compensated by return-water temperature.

Cooler flow may be either constant or variable.

Provisions can be made for reset by either outdoor, space, or return-water temperature.

Two-digit alphanumeric diagnostic display and set point panel for set points, service diagnostics and operational quick tests.

Integral shell-and-tube cooler with dual refrigerant circuits, expanded polyvinyl chloride insulation (and electric heater cable for freeze protection) optional.

Non-ferrous condenser coils with mechanically bonded plate fins and integral subcooling circuit.

Direct-drive condenser fans and motors are supported by a formed-wire mount to reduce vibration.

Fan motors are three-phase with permanently lubricated ball bearings and inherently protected.

Multiple fans are used for head pressure control during intermediate season.

Unit can be equipped (accessory) with a two-point demand limit control (each 0-50 and 50-100%) activated remotely by an electric signal.

The unit cabinet consists of galvanized steel casing, zinc phosphatized, with an electrostatically applied baked enamel finish, capable of withstanding a 500-hour salt spray test.

Hinged control box access panels.

Alarm circuit wiring standard.

PERFORMANCE DATA

UNIT

Capacity (tons) _____
 Compressor Power Input _____ kW
 Unit Power Input _____ kW
 Minimum Outdoor Operating Temperature _____ °F
 Capacity Control Steps _____ Minimum Capacity _____ %
 Refrigerant _____
 Condenser Entering Air Temperature _____ °F
 Saturated Discharge Temperature _____ °F

COOLER

Entering Water Temperature _____ °F
 Leaving Water Temperature _____ °F
 Chilled Water Flow _____ Gpm
 Chilled Water Pressure Drop _____ ft wg
 Fouling Factor _____
 Fluid _____

ELECTRICAL DATA

Power Supply to Unit _____ Volts _____ Ph _____ Hz
 Power Supply to Control Circuit _____ Volts _____ Ph _____ Hz
 Maximum Instantaneous Current Flow _____ Amps
 Minimum Circuit Amps _____
 Maximum Fuse Amps _____
 Control Circuit Fuse Amps _____

FACTORY-INSTALLED OPTIONS

- | | |
|---|---|
| <input type="checkbox"/> Motormaster® III Control | <input type="checkbox"/> High Static Fans |
| <input type="checkbox"/> Copper-Copper Condenser Coils | <input type="checkbox"/> Hot Gas Bypass |
| <input type="checkbox"/> Brine — 15° F to 40° F LWT | <input type="checkbox"/> Non-Fused Disconnect |
| <input type="checkbox"/> Cooler Heater | <input type="checkbox"/> Precoated Aluminum Fins |
| <input type="checkbox"/> Part Winding Start | <input type="checkbox"/> Postcoated Copper Fins |
| <input type="checkbox"/> Thermostatic Expansion Valve (TXV) | <input type="checkbox"/> Postcoated Aluminum Fins |

ACCESSORIES

- | | |
|--------------------------------|--------------------------------|
| <input type="checkbox"/> _____ | <input type="checkbox"/> _____ |
| <input type="checkbox"/> _____ | <input type="checkbox"/> _____ |
| <input type="checkbox"/> _____ | <input type="checkbox"/> _____ |

CUT ALONG DOTTED LINE

CUT ALONG DOTTED LINE

CERTIFIED DIMENSION PRINT

	UNITED TECHNOLOGIES CARRIER	P O BOX 4808 SYRACUSE N. Y. 13221	THIS DOCUMENT AND THE INFORMATION CONTAINED THEREIN IS PROPRIETARY TO CARRIER CORPORATION AND SHALL NOT BE USED OR DISCLOSED TO OTHERS, IN WHOLE OR IN PART, WITHOUT THE WRITTEN AUTHORIZATION OF CARRIER CORPORATION.	SUBMISSION OF THESE DRAWINGS OR DOCUMENTS DOES NOT CONSTITUTE PART PERFORMANCE OR ACCEPTANCE OF CONTRACT

TOP VIEW

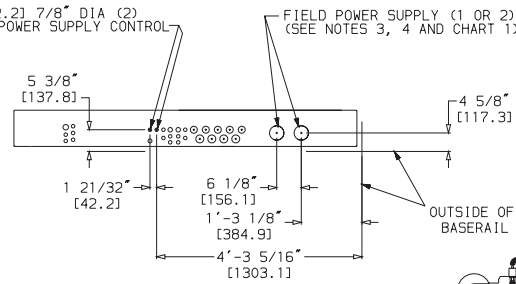
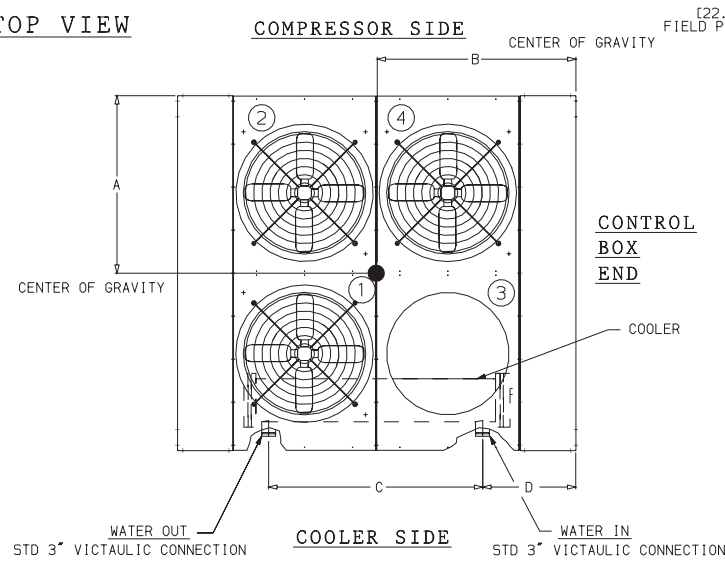

VIEW A-A

TOP VIEW OF CONTROL BOX SHELL WITH FIELD POWER SUPPLY CONNECTIONS.

RELIEF VALVE LOCATED ON A1 AND B1 COMPRESSORS

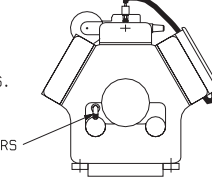

DETAIL B

RELIEF VALVES ARE EQUIPPED WITH A 3/8" SAE FLARE FOR FIELD CONNECTION

UNIT	DIMENSION A	DIMENSION B	DIMENSION C	DIMENSION D
30GT/GN/GU040	3'-5 11/16" [1059]	3'-10 13/16" [1189]	4'-5 1/2" [1359]	1'-11 1/8" [587.5]
30GT/GN/GU040C	3'-5 7/8" [1064]	3'-11" [1194]	4'-5 1/2" [1359]	1'-11 1/8" [587.5]
30GT/GN/GU045	3'-6 1/16" [1069]	3'-10 13/16" [1189]	5'-5 1/2" [1663]	1'-5 3/16" [436.6]
30GT/GN/GU045C	3'-6 3/16" [1072]	3'-11" [1194]	5'-5 1/2" [1663]	1'-5 3/16" [436.6]
30GT/GN/GU050	3'-5 7/8" [1064]	3'-11" [1194]	5'-5 1/2" [1663]	1'-5 3/16" [436.6]
30GT/GN/GU050C	3'-6" [1067]	3'-11 3/16" [1199]	5'-5 1/2" [1663]	1'-5 3/16" [436.6]

NOTES: 1. THE APPROXIMATE OPERATING WEIGHT OF THE UNIT IS:

- 30GT/GN/GU040 - 3590 LBS [1628 KG]
 - 30GT/GN/GU040C - 3878 LBS [1759 KG]
 - 30GT/GN/GU045 - 3736 LBS [1694 KG]
 - 30GT/GN/GU045C - 4024 LBS [1825 KG]
 - 30GT/GN/GU050 - 3916 LBS [1776 KG]
 - 30GT/GN/GU050C - 4349 LBS [1972 KG]
- WEIGHTS ARE BASED ON 50HZ UNITS.

- UNIT MUST HAVE CLEARANCES FOR AIR FLOW AS FOLLOWS:
 TOP - DO NOT RESTRICT IN ANY WAY.
 ENDS - [1524 MM] 5 FT
 SIDES - [1829 MM] 6 FT
- (2) 2.00" DIA HOLES WOULD BE RECOMMENDED FOR PARALLEL CONDUCTORS ON 040 AND 045 (208/230 VOLT) UNITS.
- (1) 3 5/8" DIA HOLES WOULD BE RECOMMENDED FOR SINGLE ENTRY POWER ON 050 (208/230 VOLT) UNITS.
- MOUNTING HOLES MAY BE USED TO MOUNT UNIT TO CONCRETE PAD. THEY ARE NOT RECOMMENDED FOR SPRING ISOLATOR LOCATION.
- IF SPRING ISOLATORS ARE USED, A PERIMETER SUPPORT CHANNEL BETWEEN THE UNIT AND THE ISOLATORS IS RECOMMENDED.
- WHEN UNIT HAS NON FUSED DISCONNECT OPTION, POWER SIDE DOOR OPENS IN OPPOSITE DIRECTION.

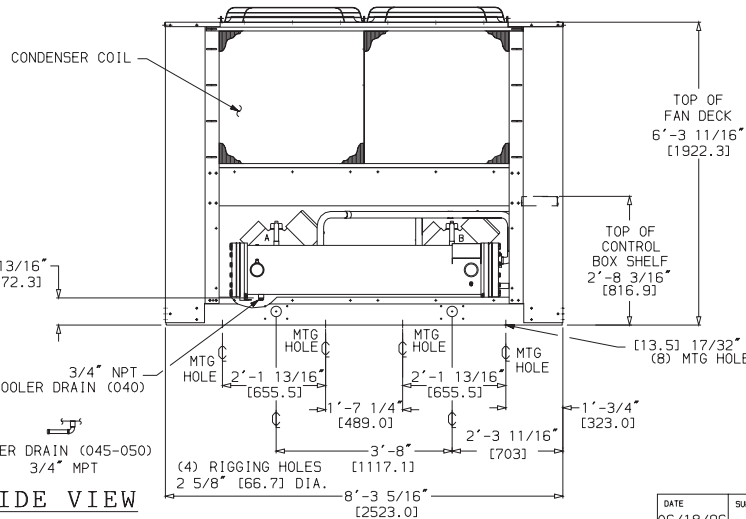

SIDE VIEW

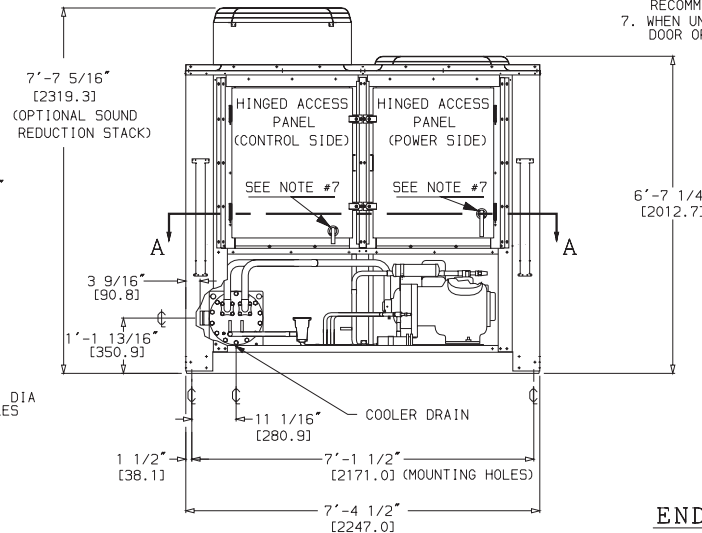

END VIEW

UNIT	VOLTAGE	HZ	DIAMETER	QTY.
040, 045	208/230	60	3 5/8" [92.0]	1
050	208/230	60	2 1/2" [63.5]	2
040-050	460	60	2 1/2" [63.5]	1
040-050	575	60	2 1/2" [63.5]	1
040-050	380	60	2 1/2" [63.5]	1
040, 045	346	50	2 1/2" [63.5]	1
050	346	50	3 5/8" [92.0]	1
040, 045	380/415	50	2 1/2" [63.5]	1
050	380/415	50	3 5/8" [92.0]	1

DATE 06/18/96	SUPSEDES 09/17/92	30GT/GN/GU040,045,050 AIR COOLED LIQUID CHILLER	30GT512157	REV A
------------------	----------------------	---	------------	----------

CERTIFIED DIMENSION PRINT

	UNITED TECHNOLOGIES CARRIER	P O BOX 4808 SYRACUSE N. Y. 13221	THIS DOCUMENT AND THE INFORMATION CONTAINED THEREIN IS PROPRIETARY TO CARRIER CORPORATION AND SHALL NOT BE USED OR DISCLOSED TO OTHERS, IN WHOLE OR IN PART, WITHOUT THE WRITTEN AUTHORIZATION OF CARRIER CORPORATION.	SUBMISSION OF THESE DRAWINGS OR DOCUMENTS DOES NOT CONSTITUTE PART PERFORMANCE OR ACCEPTANCE OF CONTRACT
--	--------------------------------	---	--	--

TOP VIEW

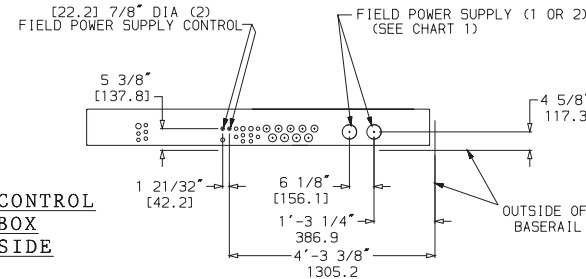
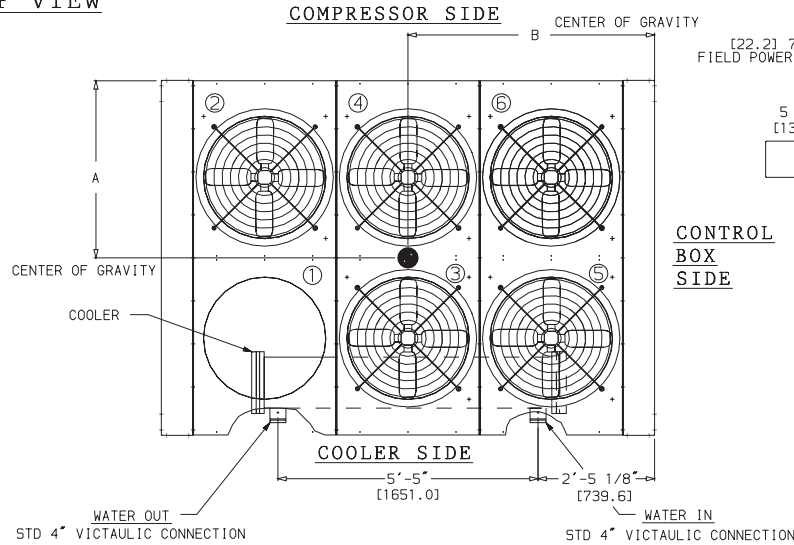

VIEW A-A

TOP VIEW OF CONTROL BOX SHELF WITH FIELD POWER SUPPLY CONNECTIONS.

UNIT	DIMENSION A	DIMENSION B
30GT/GN/GU060	3'-6 7/8" [1090]	4'-10 5/16" [1481]
30GT/GN/GU060C	3'-7" [1092]	4'-10 9/16" [1488]
30GT/GN/GU070	3'-6" [1067]	4'-10 1/2" [1486]
30GT/GN/GU070C	3'-6 3/16" [1072]	4'-10 7/8" [1496]

NOTES:

1. THE APPROXIMATE OPERATING WEIGHT OF THE UNIT IS:
 30GT/GN/GU060 - 4780 LBS [2168 KG]
 30GT/GN/GU060C - 5197 LBS [2357 KG]
 30GT/GN/GU070 (60HZ) - 5028 LBS [2280 KG]
 30GT/GN/GU070C (60HZ) - 5656 LBS [2565 KG]
 30GT/GN/GU070 (50HZ) - 5453 LBS [2473 KG]
 30GT/GN/GU070C (50HZ) - 6081 LBS [2758 KG]
 060 WEIGHTS ARE BASED ON 50HZ UNITS.
2. UNIT MUST HAVE CLEARANCES FOR AIR FLOW AS FOLLOWS:
 TOP - DO NOT RESTRICT IN ANY WAY.
 ENDS - [1524 MM] 5 FT
 SIDES - [1829 MM] 6 FT
3. MOUNTING HOLES MAY BE USED TO MOUNT UNIT TO CONCRETE PAD, THEY ARE NOT RECOMMENDED FOR SPRING ISOLATOR LOCATION.
4. IF SPRING ISOLATORS ARE USED, A PERIMETER SUPPORT CHANNEL BETWEEN THE UNIT AND THE ISOLATORS IS RECOMMENDED.
5. WHEN UNIT HAS NON FUSED DISCONNECT OPTION, POWER SIDE DOOR OPENS IN OPPOSITE DIRECTION.

UNIT	VOLTAGE	HZ	DIAMETER	QTY.
060	208/230	60	2 1/2" [63.5]	2
070	208/230	60	3 5/8" [92.0]	2
060	460	60	2 1/2" [63.5]	1
070	460	60	3 5/8" [92.0]	1
060,070	575	60	2 1/2" [63.5]	1
060,070	380	60	3 5/8" [92.0]	1
060,070	346	50	3 5/8" [92.0]	1
060,070	380/415	50	3 5/8" [92.0]	1

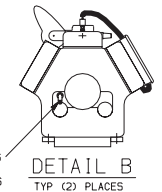
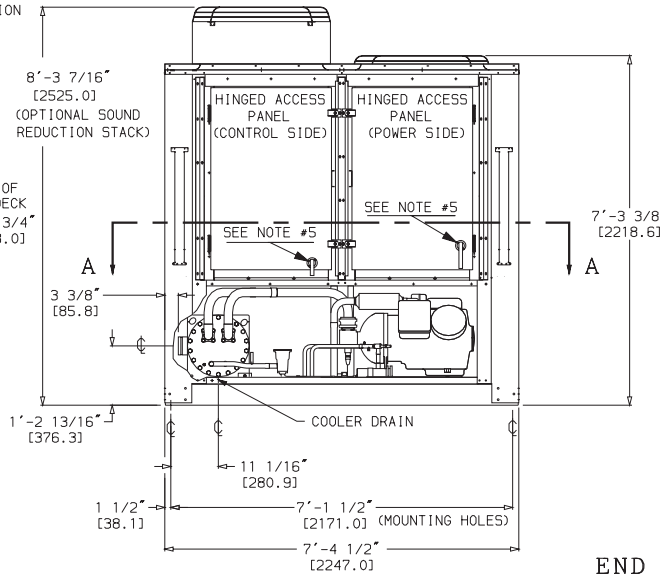
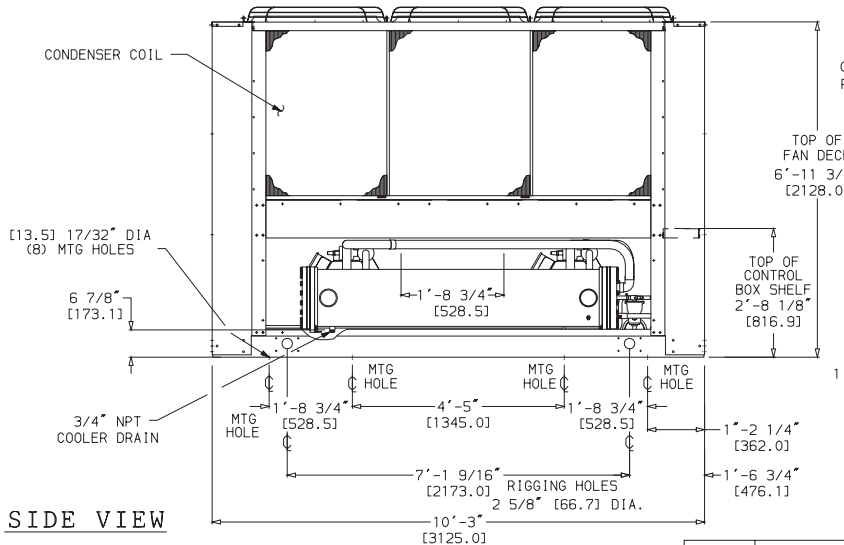

END VIEW

SIDE VIEW

DATE 06/18/96	SUPERSEDES 09/17/92	30GT/GN/GU060,070 AIR COOLED LIQUID CHILLER	30GT512158	REV A
------------------	------------------------	---	------------	----------

CUT ALONG DOTTED LINE

CUT ALONG DOTTED LINE

CERTIFIED DIMENSION PRINT



P O BOX 4808
SYRACUSE N. Y.
13221

THIS DOCUMENT IS THE PROPERTY OF CARRIER CORPORATION AND IS DELIVERED UPON THE EXPRESS CONDITION THAT THE CONTENTS WILL NOT BE DISCLOSED OR USED WITHOUT CARRIER CORPORATION'S WRITTEN CONSENT.

SUBMISSION OF THESE DRAWINGS OR DOCUMENTS DOES NOT CONSTITUTE PART PERFORMANCE OR ACCEPTANCE OF CONTRACT

NOTES:

1. THE APPROXIMATE OPERATING WEIGHT OF THE UNIT IS:
30GT/GN/GU080 - 6720 LBS [3055 KG]
30GT/GN/GU080C - 7445 LBS [3384 KG]
2. UNIT MUST HAVE CLEARANCES FOR AIR FLOW AS FOLLOWS:
TOP - DO NOT RESTRICT IN ANY WAY
ENDS - [1524 MM] 5 FT
SIDES - [1829 MM] 6 FT
3. MOUNTING HOLES MAY BE USED TO MOUNT UNIT TO CONCRETE PAD. THEY ARE NOT RECOMMENDED FOR SPRING ISOLATOR LOCATION.
4. IF SPRING ISOLATORS ARE USED, A PERIMETER SUPPORT CHANNEL BETWEEN THE UNIT AND THE ISOLATORS IS RECOMMENDED.
5. WHEN UNIT HAS NON FUSED DISCONNECT OPTION, POWER SIDE DOOR OPENS IN OPPOSITE DIRECTION.

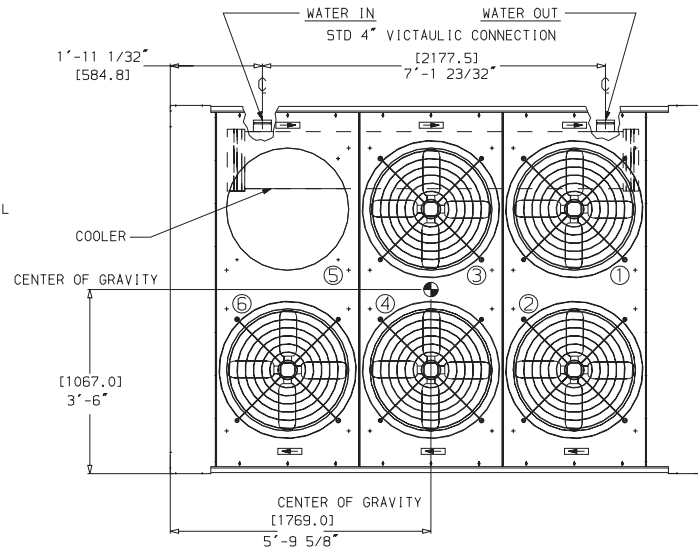
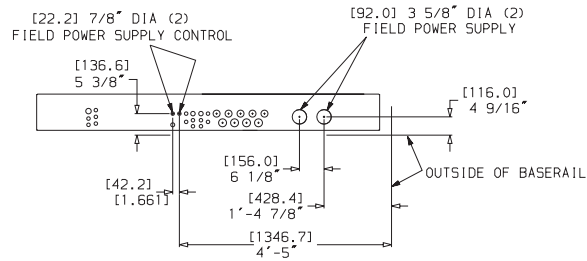

TOP VIEW

RELIEF VALVE LOCATED ON A2 AND B1 COMPRESSORS

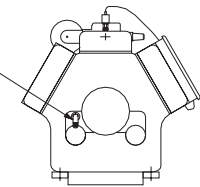

DETAIL B
TYP (2) PLACES

RELIEF VALVES ARE EQUIPPED WITH A 3/8" SAE FLARE FOR FIELD CONNECTION

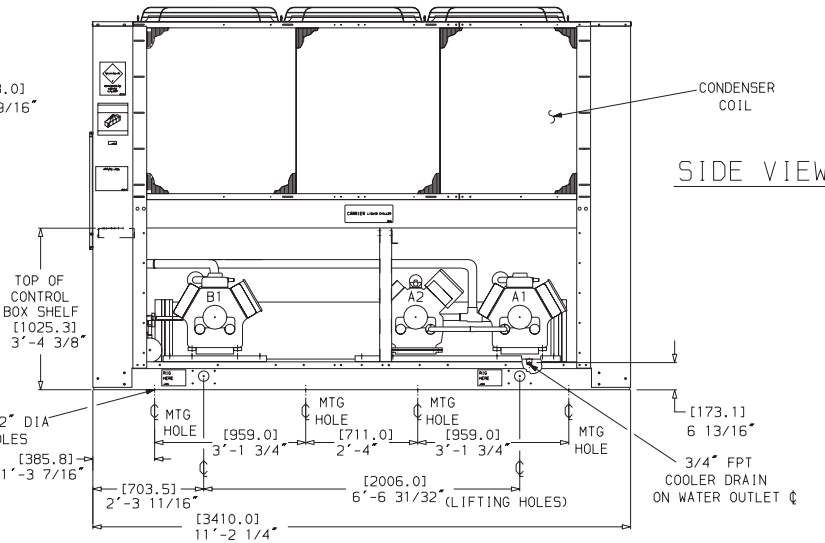
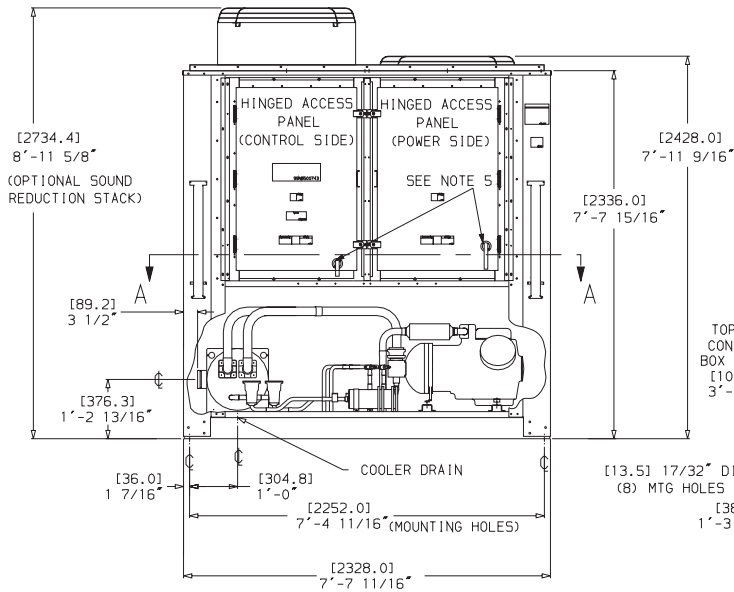

DATE 09/09/96	SUPERSEDES 10/07/92	30GT/GN/GU080 AIR COOLED LIQUID CHILLER	30GT511894	REV D
------------------	------------------------	---	------------	----------

CERTIFIED DIMENSION PRINT

 UNITED TECHNOLOGIES CARRIER	P. O. BOX 4808 SYRACUSE N. Y. 13221	THIS DOCUMENT IS THE PROPERTY OF CARRIER CORPORATION AND IS DELIVERED UPON THE EXPRESS CONDITION THAT THE CONTENTS WILL NOT BE DISCLOSED OR USED WITHOUT CARRIER CORPORATION'S WRITTEN CONSENT.	SUBMISSION OF THESE DRAWINGS OR DOCUMENTS DOES NOT CONSTITUTE PART PERFORMANCE OR ACCEPTANCE OF CONTRACT
--	---	---	--

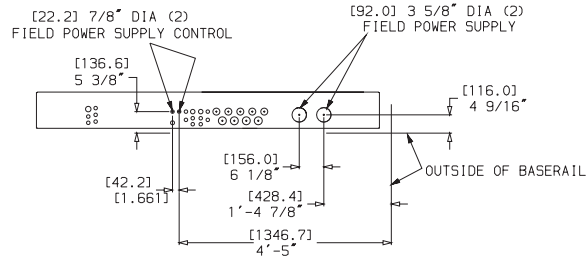

VIEW A-A

TOP VIEW OF CONTROL BOX SHELF WITH FIELD POWER SUPPLY CONNECTIONS

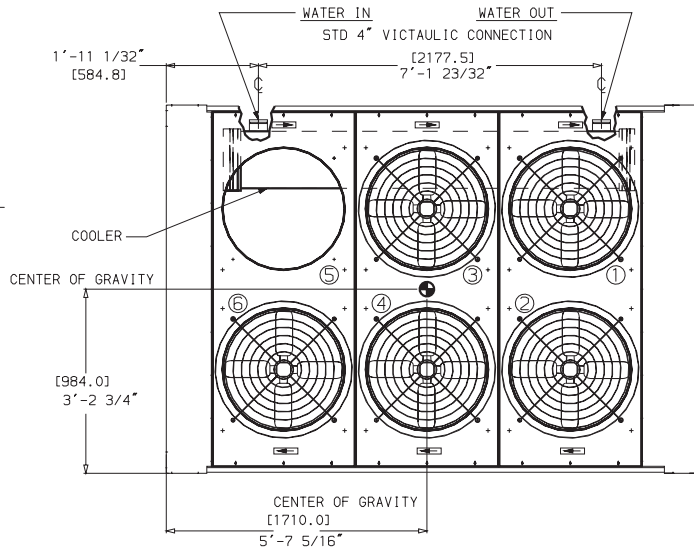

NOTES:

1. THE APPROXIMATE OPERATING WEIGHT OF THE UNIT IS:
30GT/GN/GU090 - 7135 LBS [3243 KG]
30GT/GN/GU090C - 7860 LBS [3573 KG]
2. UNIT MUST HAVE CLEARANCES FOR AIR FLOW AS FOLLOWS:
TOP - DO NOT RESTRICT IN ANY WAY
ENDS - [1524 MM] 5 FT
SIDES - [1829 MM] 6 FT
3. MOUNTING HOLES MAY BE USED TO MOUNT UNIT TO CONCRETE PAD, THEY ARE NOT RECOMMENDED FOR SPRING ISOLATOR LOCATION.
4. IF SPRING ISOLATORS ARE USED, A PERIMETER SUPPORT CHANNEL BETWEEN THE UNIT AND THE ISOLATORS IS RECOMMENDED.
5. WHEN UNIT HAS NON FUSED DISCONNECT OPTION, POWER SIDE DOOR OPENS IN OPPOSITE DIRECTION.

TOP VIEW

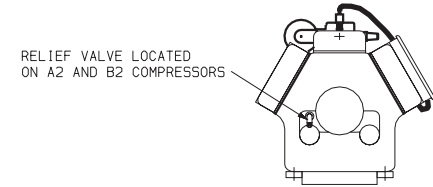

DETAIL B

TYP (2) PLACES

RELIEF VALVES ARE EQUIPPED WITH A 3/8\"/>

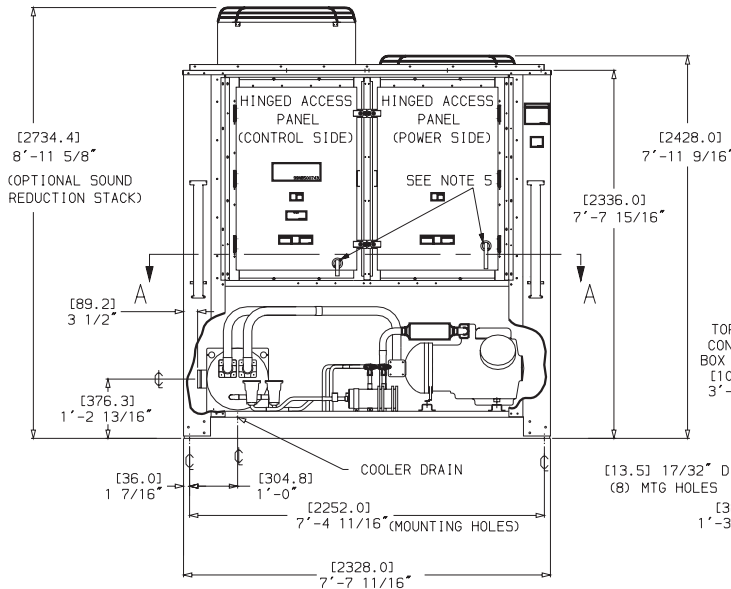

END VIEW

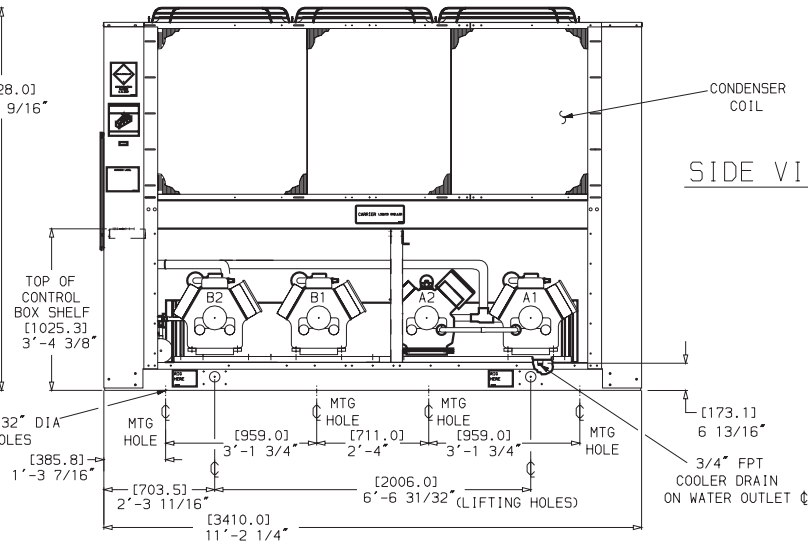

SIDE VIEW

DATE 09/09/96	SUPERSEDES 10/07/92	30GT/GN/GU090 AIR COOLED LIQUID CHILLER	30GT511895	REV D
------------------	------------------------	---	------------	----------

CUT ALONG DOTTED LINE

CUT ALONG DOTTED LINE

CERTIFIED DIMENSION PRINT



UNITED TECHNOLOGIES CARRIER

P O BOX 4808
SYRACUSE N. Y.
13221

THIS DOCUMENT IS THE PROPERTY OF CARRIER CORPORATION AND IS DELIVERED UPON THE EXPRESS CONDITION THAT THE CONTENTS WILL NOT BE DISCLOSED OR USED WITHOUT CARRIER CORPORATION'S WRITTEN CONSENT.

SUBMISSION OF THESE DRAWINGS OR DOCUMENTS DOES NOT CONSTITUTE PART PERFORMANCE OR ACCEPTANCE OF CONTRACT

NOTES:

1. THE APPROXIMATE OPERATING WEIGHT OF THE UNIT IS:
30GT/GN/GU100 - 8710 LBS [3960 KG]
30GT/GN/GU100C - 9660 LBS [4390 KG]
30GT/GN/GU110 - 8840 LBS [4018 KG]
30GT/GN/GU110C - 9790 LBS [4450 KG]
2. UNIT MUST HAVE CLEARANCES FOR AIR FLOW AS FOLLOWS:
TOP - DO NOT RESTRICT IN ANY WAY
ENDS - [1524 MM] 5 FT
SIDES - [1829 MM] 6 FT
3. MOUNTING HOLES MAY BE USED TO MOUNT UNIT TO CONCRETE PAD. THEY ARE NOT RECOMMENDED FOR SPRING ISOLATOR LOCATION.
4. IF SPRING ISOLATORS ARE USED, A PERIMETER SUPPORT CHANNEL BETWEEN THE UNIT AND THE ISOLATORS IS RECOMMENDED.
5. 30GT/GN100 ALSO MODULE B FOR 30GT/GN240,270.
6. WHEN UNIT HAS NON FUSED DISCONNECT OPTION, POWER SIDE DOOR OPENS IN OPPOSITE DIRECTION.

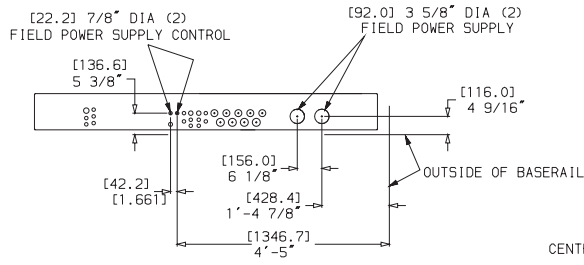

VIEW A-A

TOP VIEW OF CONTROL BOX SHELF WITH FIELD POWER SUPPLY CONNECTIONS

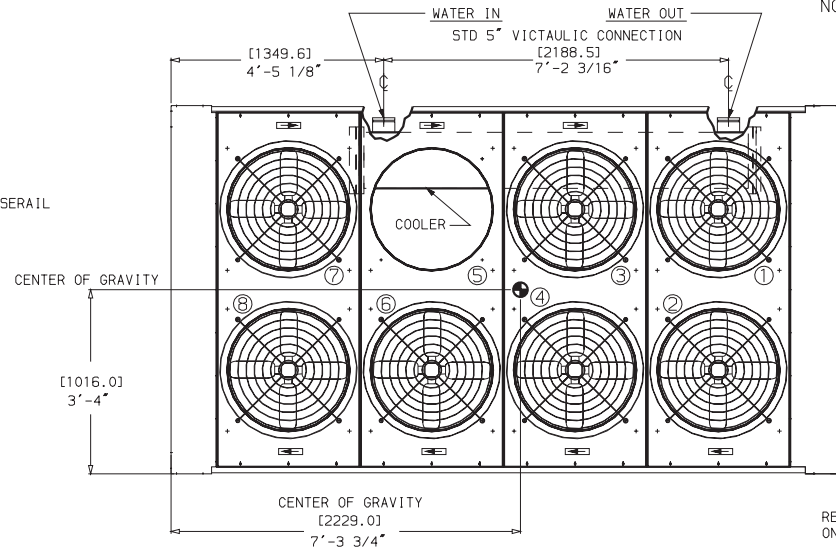

TOP VIEW

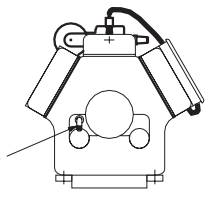

DETAIL B
TYP (2) PLACES

RELIEF VALVES ARE EQUIPPED WITH A 3/8\" SAE FLARE FOR FIELD CONNECTION

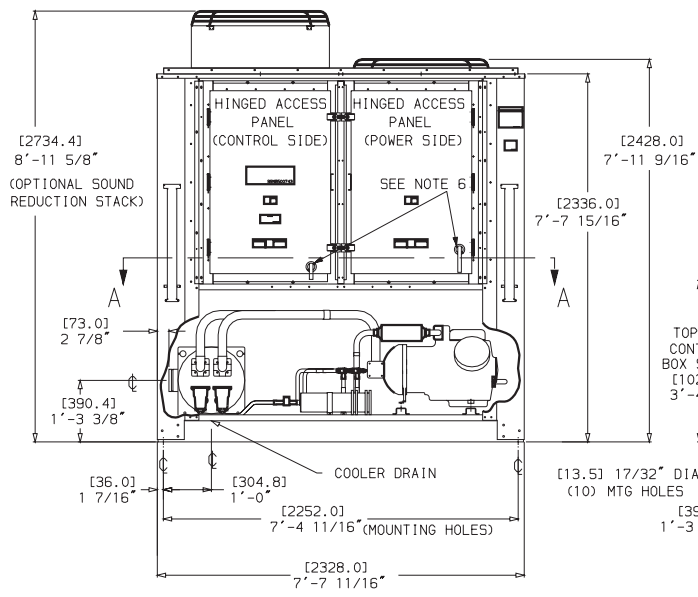

END VIEW

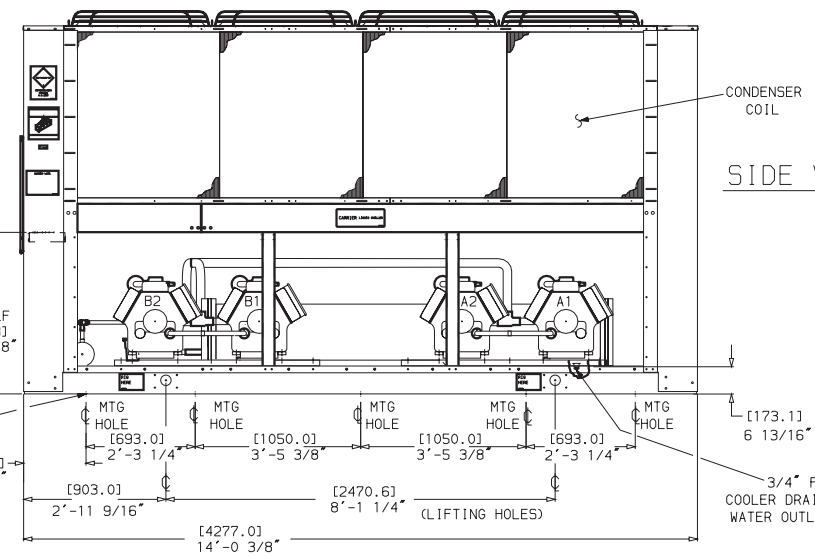

SIDE VIEW

DATE 09/09/96	SUPSEDES 08/05/93	30GT/GN/GU100-110 AIR COOLED LIQUID CHILLER	30GT511896	REV E
------------------	----------------------	---	------------	----------

FIELD WIRING DIAGRAM



UNITED TECHNOLOGIES CARRIER
P O BOX 4808 SYRACUSE N. Y. 13221

THIS DOCUMENT IS THE PROPERTY OF CARRIER CORPORATION AND IS DELIVERED UPON THE EXPRESS CONDITION THAT THE CONTENTS WILL NOT BE DISCLOSED OR USED WITHOUT CARRIER CORPORATION'S WRITTEN CONSENT.

SUBMISSION OF THESE DRAWINGS OR DOCUMENTS DOES NOT CONSTITUTE PART PERFORMANCE OR ACCEPTANCE OF CONTRACT

NOTES:

- FACTORY WIRING IS IN ACCORDANCE WITH NATIONAL ELECTRICAL CODE (NEC). FIELD MODIFICATIONS OR ADDITIONS MUST BE IN COMPLIANCE WITH ALL APPLICABLE CODES.
- WIRING FOR MAIN FIELD POWER SUPPLY MUST BE RATED 75°C MINIMUM. USE COPPER, COPPER CLAD ALUMINUM OR ALUMINUM CONDUCTORS FOR ALL UNITS.
- POWER FOR CONTROL CIRCUIT SHOULD BE SUPPLIED FROM A SEPARATE SOURCE THROUGH A FIELD SUPPLIED FUSED DISCONNECT WITH 30 AMP MAXIMUM PROTECTION FOR 115 VOLT CONTROL CIRCUITS AND 20 AMP MAXIMUM PROTECTION FOR 230 VOLT CONTROL CIRCUIT FOR A UNIT WITH COOLER HEATERS. 5 AMP MAXIMUM FOR A UNIT WITHOUT COOLER HEATERS. CONNECT CONTROL CIRCUIT POWER TO TERMINALS 1 AND 2 OF TB4. CONNECT NEUTRAL SIDE OF SUPPLY TO TERMINAL 2 OF TB4. CONTROL CIRCUIT CONDUCTORS FOR ALL UNITS MUST BE COPPER ONLY.
- TERMINALS 3 & 4 OF TB6 ARE FOR FIELD CONNECTION FOR REMOTE ON-OFF CONTROL. THE CONTACTS MUST BE RATED FOR DRY CIRCUIT APPLICATION CAPABLE OF RELIABLY SWITCHING A 5VDC, .5MA. LOAD. REMOVE JUMPER BETWEEN 3 & 4 OF TB6 IF REMOTE ON-OFF IS INSTALLED.
- THE MAXIMUM LOAD ALLOWED FOR THE REMOTE ALARM CIRCUIT IS 75 VA SEALED, 360 VA INRUSH AT 115 OR 230 VOLT, DEPENDING ON MODEL. REMOVE RESISTOR ACROSS TERMINALS 1 & 2 OF TB5 WHEN USING REMOTE ALARM.

LEGEND:

- A - ALARM
- CWFS - CHILLED WATER FLOW SWITCH
- CWP1 - CHILLED WATER PUMP INTERLOCK
- TB - TERMINAL BLOCK
- (thick) — FIELD POWER WIRING
- (thin) — FIELD CONTROL WIRING
- (dashed) — FACTORY INSTALLED WIRING

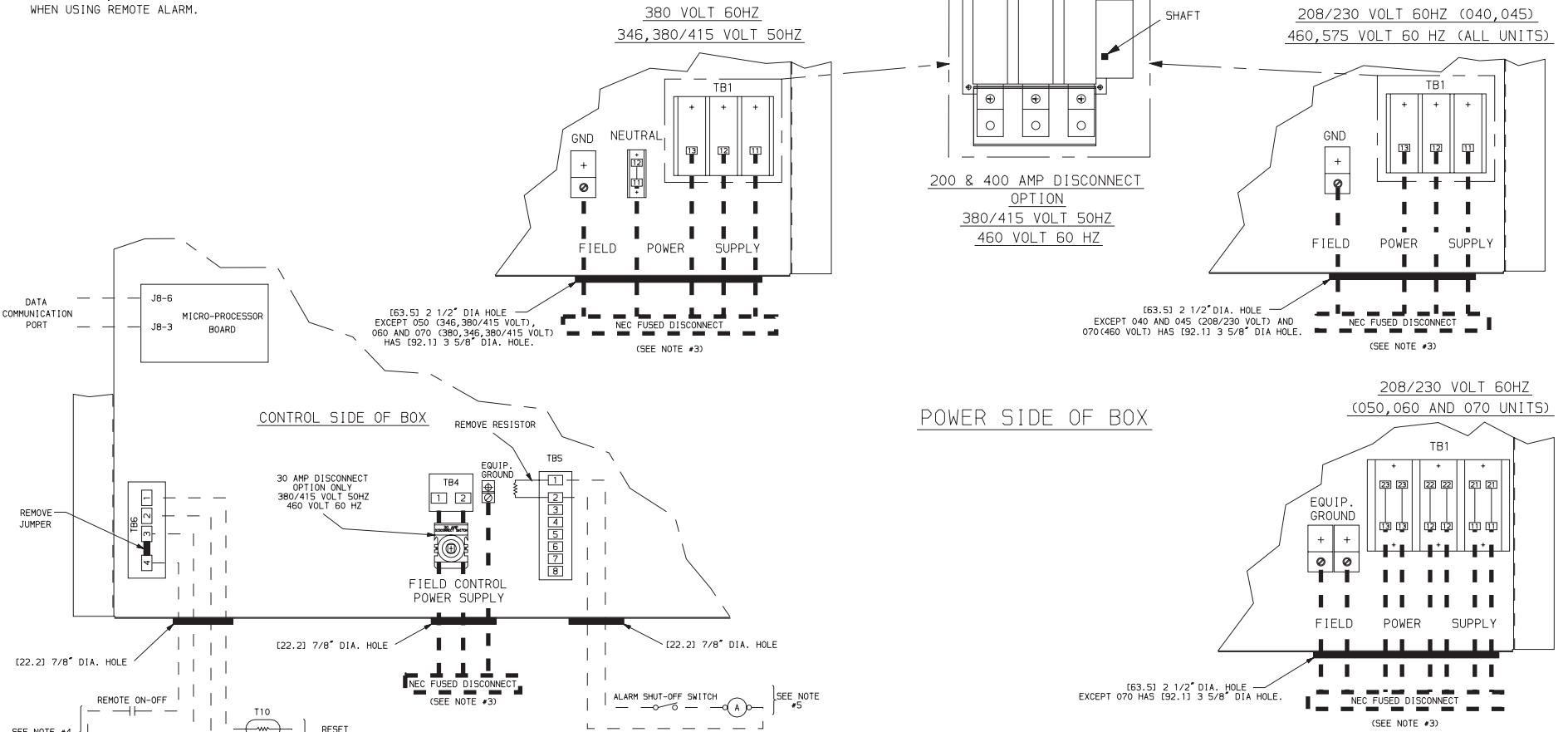

DATE 04/07/98
SUPERSEDES 06/18/96

30GT/GU040,045,050,060,070 AIR COOLED LIQUID CHILLER-FLOTRONIC I
FIELD WIRING DIAGRAM (208/230,460,575,380,346,380/415V)

30GT512159

REV B

CUT ALONG DOTTED LINE

CUT ALONG DOTTED LINE

FIELD WIRING DIAGRAM



UNITED TECHNOLOGIES
CARRIER

P O BOX 4908
SYRACUSE N. Y.
13221

THIS DOCUMENT IS THE PROPERTY OF CARRIER CORPORATION AND IS DELIVERED UPON THE EXPRESS CONDITION THAT THE CONTENTS WILL NOT BE DISCLOSED OR USED WITHOUT CARRIER CORPORATION'S WRITTEN CONSENT.

SUBMISSION OF THESE DRAWINGS OR DOCUMENTS DOES NOT CONSTITUTE PART PERFORMANCE OR ACCEPTANCE OF CONTRACT

NOTES:

- FACTORY WIRING IS IN ACCORDANCE WITH NATIONAL ELECTRICAL CODE (NEC). FIELD MODIFICATIONS OR ADDITIONS MUST BE IN COMPLIANCE WITH ALL APPLICABLE CODES.
- WIRING FOR MAIN FIELD POWER SUPPLY MUST BE RATED 75°C MINIMUM. USE COPPER, COPPER CLAD ALUMINUM OR ALUMINUM CONDUCTORS FOR ALL UNITS EXCEPT USE COPPER CONDUCTORS ONLY FOR THE 30GT110 346 VOLT UNIT (XL & PW), AND THE 30GT110 380/415 VOLT PART WINDING START UNIT.
- POWER FOR CONTROL CIRCUIT SHOULD BE SUPPLIED FROM A SEPARATE SOURCE THROUGH A FIELD SUPPLIED FUSED DISCONNECT WITH 30 AMP MAXIMUM PROTECTION FOR 115 VOLT CONTROL CIRCUITS AND 15 AMP MAXIMUM PROTECTION FOR 230 VOLT CONTROL CIRCUIT FOR A UNIT WITH COOLER HEATERS, 5 AMP MAXIMUM FOR A UNIT WITHOUT COOLER HEATERS. CONNECT CONTROL CIRCUIT POWER TO TERMINALS 1 AND 2 OF TB4. CONNECT NEUTRAL SIDE OF SUPPLY TO TERMINAL 2 OF TB4. CONTROL CIRCUIT CONDUCTORS FOR ALL UNITS MUST BE COPPER ONLY.
- TERMINALS 3 & 4 OF TB6 ARE FOR FIELD CONNECTION FOR REMOTE ON-OFF CONTROL. THE CONTACTS MUST BE RATED FOR DRY CIRCUIT APPLICATION CAPABLE OF RELIABLY SWITCHING A 5VDC, .5MA. LOAD. REMOVE JUMPER BETWEEN 3 & 4 OF TB6 IF REMOTE ON-OFF IS INSTALLED.
- THE MAXIMUM LOAD ALLOWED FOR THE REMOTE ALARM CIRCUIT IS 75 VA SEALED, 360 VA INRUSH AT 115 OR 230 VOLT, DEPENDING ON MODEL. REMOVE RESISTOR ACROSS TERMINALS 1 & 2 OF TB5 WHEN USING REMOTE ALARM.

LEGEND:

- A - ALARM
- CWFS - CHILLED WATER FLOW SWITCH
- CWPI - CHILLED WATER PUMP INTERLOCK
- TB - TERMINAL BLOCK
- FIELD POWER WIRING
- - - FIELD CONTROL WIRING
- FACTORY INSTALLED WIRING

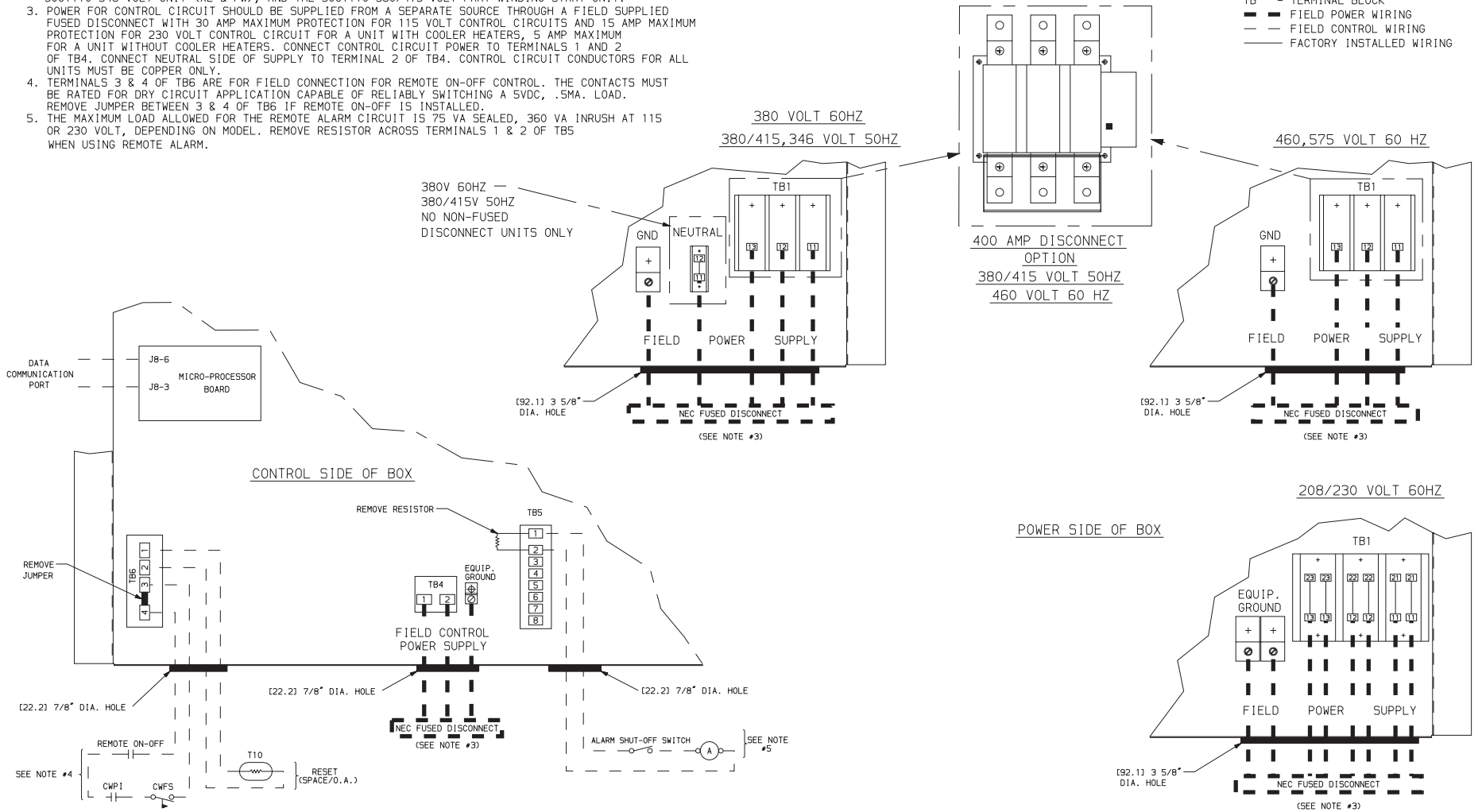

DATE 3/19/97	SUPERSEDES 10/15/96	30GT/GU080,090,100,110 AIR COOLED LIQUID CHILLER-FLO I FIELD WIRING DIAGRAM (208/230,460,575,380,346,380/415V)	30GT511898	REV C
-----------------	------------------------	---	------------	----------