

SC-Equipment Communication Card

Product Bulletin



Form 450.50-PB1 (816)
 Issued August 8, 2016
 Supersedes: June 23, 2016

The Johnson Controls® SC-EQ (Smart Chiller Equipment) Communication Card is an economical and versatile communications device that provides a communication connection between Johnson Controls® York equipment and standard open BAS protocols. It efficiently manages all of the communication protocols used by York equipment, exposing the data in a consistent, organized, and defined fashion.

The SC-EQ Communication Card is available as a card (Figure 1) that can be fitted directly inside an Optiview or Latitude based equipment control panel, or supplied within a line voltage-enabled enclosure to be mounted externally from the control panel. The SC-EQ detects the chiller model and the BAS protocol and then automatically configures itself to communicate with both.

The installer typically only needs to set the MAC network address DIP switch. Some of the older chillers may need to have their chiller model set manually using the SC-AP.

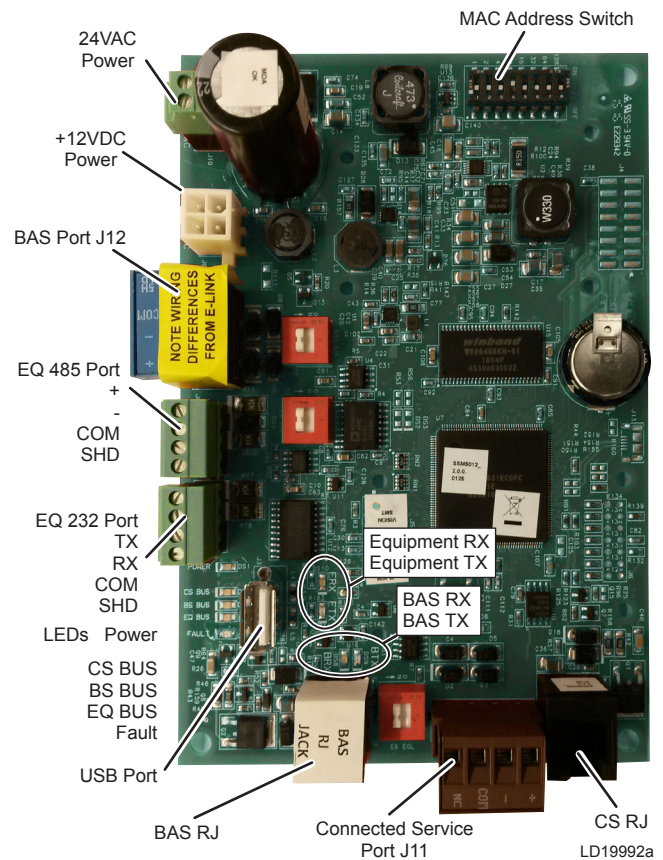

FIGURE 1 - SC-EQ COMMUNICATION CARD

TABLE 1 - FEATURES AND BENEFITS

FEATURES	BENEFITS
BACnet® Master-Slave/Token-Passing (MS/TP), N2, and Modbus® Remote Terminal Unit (RTU) Outputs	Enables equipment connectivity to industry-standard open network protocols.
Automatically Detects Chiller Model and BAS	Simplifies the equipment connectivity, commissioning and startup.
Removable Connectors	Simplifies installation and future service.
Connected Service Port	With the addition of the SC-AP MAP Gateway device and a connection path to the internet, allows JCI Connected Offerings remote equipment monitoring and diagnostics.

APPLICATIONS

The SC-EQ Communication Card replaces the York E-Links and MicroGateways. It consolidates the previously supported equipment profiles into a single application.

TABLE 2 - ORDERING INFORMATION

PART NUMBER	DESCRIPTION
SE-SCC1001-1 031-03610-000	SC-EQ with Serial Outputs (BACnet MS/TP, Modbus RTU, and N2)
YK-SCCPNL-0	SC-EQ with Serial Outputs in an Enclosure
331-03607-000	OptiView Panel Installation Kit
392-41228-000	Screw Chiller Installation Kit
392-41230-001	Scroll Chiller Installation Kit

NOTE: LON integration requires a LON E-Link.

The SC-EQ Communication Card is used to provide most Johnson Controls/York mechanical equipment, such as chillers and rooftop units, with Building Automation System (BAS) networking connectivity.

CONFIGURATION METHOD

The SC-EQ will automatically detect the equipment model and expose only the parameters that exist on the unit. In some cases the equipment program may need to be updated to support this automatic configuration feature. In cases where there is no update available for the program to provide the auto-detect capability, the user will need to use an SC-AP to manually select the chiller model.

The SC-EQ will also automatically detect the connected BAS protocol and baud rate and adjust itself to match.

The Media Access Control (MAC) address switch is the only switch settings the user must set. This sets the address of the SC-EQ device on the network. This setting may be set by the startup technician if the address is known at startup time or, it may be easily set by the controls technician later during BAS commissioning.

FIELD DIAGNOSTICS

Field troubleshooting may be performed visually by observing the communication ports and status Light-Emitting Diodes (LEDs). Further diagnostics may be performed using a SC-AP MAP Gateway and a digital multimeter. Troubleshooting procedures are detailed in Form 450.50-N1.

PORT FUNCTIONALITY

The SC-EQ Communication Card is designed with three active serial ports and supports concurrent access of equipment data on Ports J12 and J11.

BAS Port J12

This isolated RS-485 serial port is used to connect the SC-EQ Communication Card to a BAS using one of the following BAS networking protocols:

- BACnet MS/TP
- N2
- Modbus RTU

A BAS Receive (BRX) and a BAS Transmit (BTX) LED indicates communication activity to assist with integration problem diagnosis.

Equipment Ports

These ports are reserved for connecting to the equipment. Receive (ERX) and Transmit (ETX) LEDs display port communications activity between the SC-EQ and the chiller microboard.

EQ 485 Port J8

This RS-485 port is used to connect the SC-EQ Communication Card to equipment that uses the York Talk II protocol or BACnet MS/TP protocol. This port has an EOL termination switch eliminating the need for external End of Line Terminating resistors.

EQ 232 Port J7

This RS-232 port is used to connect the SC-EQ Communication Card to equipment using the York Talk III protocol.

CS Port J11 and CS RJ

This RS-485 port is used to connect to the SC-AP MAP Gateway. The SC-AP MAP Gateway provides a Wi-Fi access point for customers and service technicians allowing them to read equipment parameters on their Wi-Fi equipped cell phone, tablet or laptop. The SC-AP MAP Gateway also provides connectivity to the internet and onwards to the cloud for the JCI Smart Equipment™ Connected Chiller Offerings. The SC-AP MAP Gateway can connect to a customer's ethernet network using CAT 5 cable or to a wireless hub using Wi-Fi. A cellular modem with Wi-Fi connectivity may also be used to provide the chiller data to the JCI Connected Offerings servers. Refer to LIT 24-10737-75 and LIT 24-10737-87 for more information on the SC-AP MAP Gateway.

INTEGRATION

To fully integrate the SC-EQ Communication Card into a BAS system, the mapped points along with their associated equipment definitions need to be known. This detailed information is provided in the York Equipment Data Maps that are available from your local Johnson Controls representative. The SC-EQ will determine which points are valid for the options installed in a particular chiller and only expose those points to the BAS.

When integrating to a BACnet BAS system, the points and their descriptive points names are discoverable eliminating the need to pre-engineer the integration.

BACnet Protocol

The SC-EQ is listed with the BACnet Testing Laboratories (BTL) as a B-ASC device. The SC-EQ Communication Card supports the following BACnet baud rates: (9600, 19200, 38400 and 76800). The standard BACnet object types used for the interface are: (AV, BV and MV). AV Analog Values are used to represent temperatures, pressure and percentages. Certain AV points may be written to set temperature setpoint and current limit. BV Binary Values represent ON/OFF or OPEN/CLOSED states. Certain BV points may be written to START/STOP the chiller.

Modbus RTU

The SC-EQ Communication Card supports the following baud rates and parity: (9600-N-8-1, 9600-E-8-1, 19200-N-8-1, 19200-N-8-2)

The following Modbus function codes are supported:

- 1 – Read Coil Status
- 2 – Read Input Status
- 3 – Read Holding Registers
- 4 – Read Input Register
- 5 – Force Single Coil
- 6 – Preset Single Register
- 15 – Force Multiple Coils
- 16 – Force Multiple Registers

N2

The SC-EQ Communication Card supports the N2 open protocol and operates at 9600 baud. Data is presented using Analog Data Input (ADI), Analog Data Float (ADF), and Binary Data (BD) objects.

The SC-EQ supports the following N2 commands:

- Synch Time
- Poll without/with ACK Message
- Read Internal Parameter
- Override Internal Parameter
- Override Release Parameter
- Identity Device Type

Technical Specifications

SC-EQ Communication Card

Power Requirements	Input Voltage	24 VAC at 50/60 Hz (+10%/-15%) 12 VDC (+50%/-2%)
	Power Consumption	Nominally 12 VA, 400mA
Ambient Operating Conditions		-40 to 149°F (-40 to 65°C) 5 to 95% RH Noncondensing
Ambient Storage Conditions		-40 to 185°F (-40 to 85°C) 5 to 95% RH Noncondensing
Communications	BAS Port J12	2.5 KV isolated BAS networking port (RS-485 – BACnet MS/TP, N2, Modbus RTU)
	EQ 485 Port J8	Equipment port (RS-485 – York Talk II or BACnet MS/TP)
	EQ 232 Port J7	Equipment port (RS-232 – York Talk III)
	CS Port J11, RJ	Connected Services Monitoring port
User Functions	Communication Status	Each communication port has a status LED. The Equipment and BAS ports also have LEDs for Transmit and Receive to assist in integration diagnosis.
	Fault LED	Flashing LED indicates firmware error codes.
	Power LED	Green LED that illuminates when power is supplied to the SC-EQ
	MAC Address	DIP switch sets network address between 1 and 127
	USB Connector	USB 2.0 connector for updating SC-EQ firmware using a USB thumbdrive
	EOL Switch	Each RS-485 port has an End-of-Line (EOL) network that is switch-selectable
Shipping Weight	Circuit Board	8 oz (227 g)
	Metal Enclosure and Transformer	4.5 lb (2 kg)
Agency Listings		Safety: UL 916 cULus, UL 60730-1, Enclosure version UL508A EMC Conducted and Radiated: FCC CFR47 Part 15 Subpart B Class B CISPR 22, RCM ACMA AS/NZS 61000.6.3, CE EMC Directive 2004/108/EC EN 61000-6-2 and EN 61000-6-3, IC ICES-003 Class B

The performance specifications are nominal and conform to acceptable industry standards. For application at conditions beyond these specifications, consult the local Johnson Controls office. Johnson Controls, Inc. shall not be liable for damages resulting from misapplication or misuse of its products.



Building Efficiency

507 E. Michigan Street, Milwaukee, WI 53202

*Metasys® and Johnson Controls® are registered trademarks of Johnson Controls, Inc.
All other marks herein are the marks of their respective owners. © 2016 Johnson Controls, Inc.*