

# Model F Burner Instruction Manual

FOR  
GAS AND PRESSURE ATOMIZING LIGHT OIL FUEL SYSTEMS  
MANUFACTURED BY JOHN ZINK COMPANY, LLC

**NOTE:** YOUR BURNER MAY HAVE A LETTER PREFIX OR SUFFIX ADDED TO THE MODEL DESIGNATION. HOWEVER, THIS IS FOR IDENTIFICATION PURPOSES ONLY AND DOES NOT AFFECT THE INSTRUCTIONS IN THIS MANUAL.



Cici Boiler Rooms, Inc.

***Cici Boiler Rooms is  
your source for boiler and  
burner replacement parts!***

1-800-848-8197

[sales@ciciboilers.com](mailto:sales@ciciboilers.com)

[www.GordonPiattParts.com](http://www.GordonPiattParts.com)

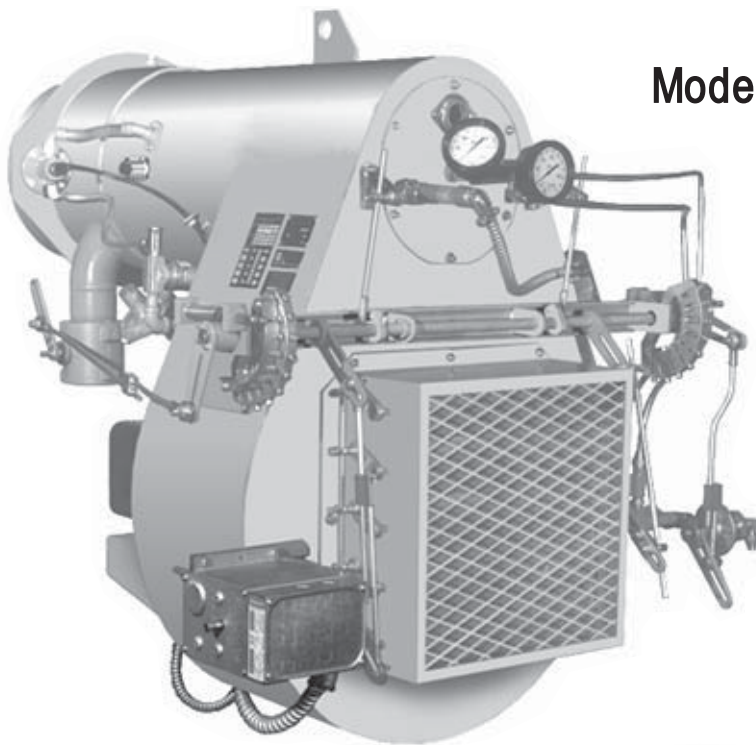

**Model F Burner**

**Model FL  
Burner**

Model FL has low profile for use where space is limited or to avoid pitting in front of the boiler.

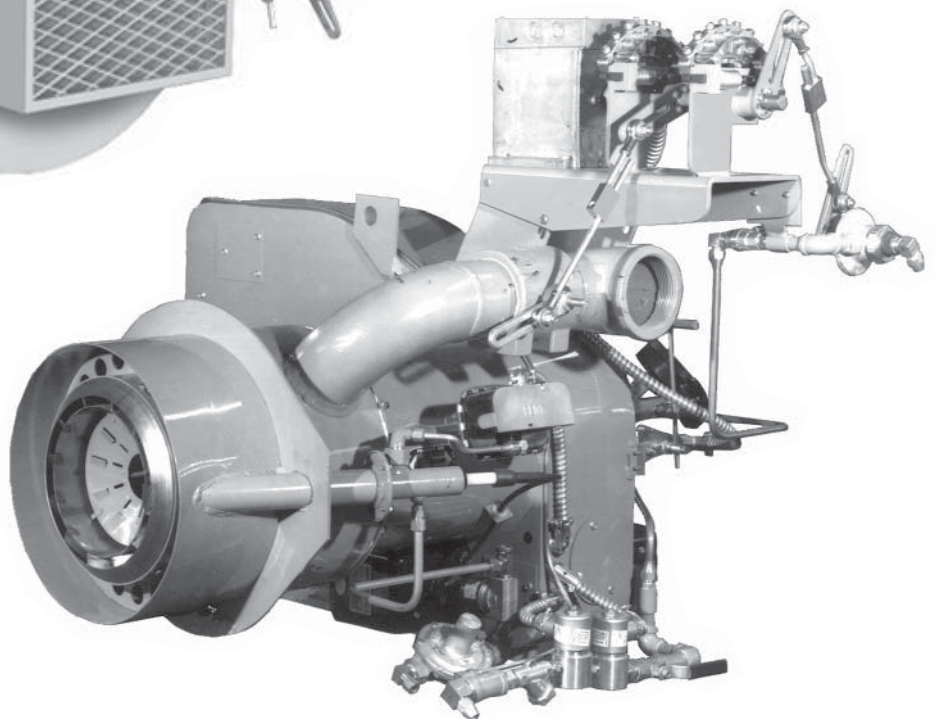

# TABLE OF CONTENTS

PART I	- SUGGESTED INSTALLATION INSPECTION CHECKLIST	3
PART II	- GENERAL	4
PART III	- BURNER FAMILIARIZATION AND PRELIMINARY INSPECTION	5-6
PART IV	- SYSTEM DESCRIPTION	7-11
	General	7
	Gas Piping Information	7-8
	Oil Piping Information	9-11
PART V	- PRELIMINARY ADJUSTMENTS	12-30
	■ Primary-Secondary Air Cylinder	13
	■ Air Inlet Louver Box	14
	■ Gas Pilot Ignitor	15-16
	Pilot Trouble Shooting	17
	■ Butterfly Gas Valve	18
	■ Gas Pressure Regulators	19
	■ Gas Pressure Switches	20
	■ Oil Drawer Assembly	20-24
	■ Oil Metering Valve	25
	■ Oil Supply Pressure Regulator Valve	26
	■ Low Oil Pressure Switch	27
	■ Characterized Linkage	28
	■ Air Flow Switch (Diaphragm)	29
	■ Air Flow Switch (Sail)	29-30
PART VI	- BURNER START-UP	31-37
	- Flame Safeguard Installation	31
	- Identification of Controls	31-32
	- Gas Burners	32-34
	- Oil Burners	34-37
PART VII	- TROUBLE SHOOTING	38-41
	- Trouble Shooting	38-39
	- Periodic Testing Recommended Check List	40-41
PART VIII	- SUPPLEMENTARY DATA	42

## WARNING!

### If you smell gas:

1. Open windows.
2. Don't touch electrical switches.
3. Extinguish any open flame.
4. EVACUATE people from building.
5. Immediately call the gas supplier.

The use and storage of gasoline or other flammable liquids and vapors in open containers in the vicinity of this appliance is hazardous.

In accordance with OSHA standard 1910.147, all equipment, machines and processes shall be locked out prior to servicing.

If not installed, vented, operated and maintained in accordance with the manufacturer's instructions, this product could expose you to substances in fuel or from fuel combustion which can cause death or serious illness and which are known to the State of California to cause cancer, birth defects or other reproductive harm.

Improper servicing of this equipment may create a potential hazard to equipment and operators.

### **SERVICING MUST BE DONE ONLY BY FULLY TRAINED AND QUALIFIED PERSONNEL.**

Before disconnecting or opening up a fuel line and before cleaning or replacing parts of any kind.

- Turn **OFF** the manual fuel shutoff valves including pilot gas cock, if applicable. If a multiple fuel burner, shut **OFF** all fuels.
- Turn **OFF** all electrical disconnects to the burner **and any other** equipment or systems electrically interlocked with the burner.

Do **NOT** use TEFLON TAPE or compounds with TEFLON content as an oil or gas pipe sealant. TEFLON can cause valves to fail creating a SAFETY HAZARD. Warranties are nullified and liability rests solely with the installer when evidence of TEFLON is found.

# PART I

## SUGGESTED INSTALLATION INSPECTION CHECKLIST

### GENERAL

### CHECK WHEN COMPLETED

- Is burner installed in accordance with applicable installation drawings?
- If a refractory combustion chamber is part of the installation, is it completely dry, cured, and ready for firing at full boiler input?
- Has the proper electrical voltage been connected to the burner control cabinet as shown on the burner material list?
- Has the burner wiring been checked for completeness and accuracy? Have 3-phase motors been properly wired and checked for correct rotation?
- Are the boiler mounted limit controls such as low water cutoffs, high limit controls, operating controls, modulating controls, etc., properly installed and wired?
- Are the boiler controls the right type and range for the installation?
- Is the boiler water supply, including feed pumps, properly connected and is boiler filled with water?
- Is sufficient load connected to the boiler so that it can be fired continuously at full rating?
- If boiler load is not connected, can steam be wasted so that boiler can be fired continuously at full rating without endangering personnel or equipment?
- If the installation is a hot water boiler, have the circulating pumps been completely installed, wired, and tested to assure proper operation so that the burner can be fired continuously at full rating?
- For new boiler installations, has the boiler been boiled out in accordance with the boiler manufacturer's instructions?
- Have the boiler breeching connections to the stack been completed and are they open and unobstructed?
- Is draft control equipment required and, if so, installed?
- Have adequate provisions for combustion air been installed?
- Have the persons listed below been notified of the burner start-up date?
  - Owner's Representative
  - Mechanical Contractor's Representative
  - Electrical Contractor's Representative
  - Service Organization's Representative
  - Boiler Manufacturer's Representative

- Is all specified auxiliary equipment mounted and wired? This may include outdoor temperature controls, oil flow switches, space thermostats, water flow switches, motorized combustion air louvers, etc.

### GAS FIRING

- Are all gas train components installed and have they been properly selected, sized and assembled?
- Have properly sized vent lines been installed on all gas train components which require venting? This includes such items as pressure regulators, normally open vent valves, diaphragm valves, low and high gas pressure switches, etc.
- Have gas train piping and components been tested and proven gas tight?
- Have the gas lines been purged?
- Is the proper gas pressure available at the inlet to the controls which meets the requirement shown on the burner material list?

### OIL FIRING

- Is the oil tank installed and filled with the proper type and grade of fuel oil as required by the burner material list?
- Is the proper oil pressure, temperature and viscosity available at the inlet to the controls which meets the requirements shown on the burner material list and/or oil system sheet?
- Have oil supply and return lines been properly sized to meet the maximum pumping capacity of the pump and has the system been purged and proven leak proof?

**SIGNATURE OF INSPECTOR(S)**

---

---

---

# PART II

## GENERAL

### NOTE

Installation requirements and instructions should always be covered in appropriate engineering drawings and specifications which detail the applicable building codes, etc. Information contained herein is to be used as a guide **ONLY** and not as the final authority.

- Starting a burner is an event which normally culminates the efforts of several different contractors, manufacturers, utility and engineering concerns, sales and factory representatives, and others.
- In order for the burner to operate safely and meet its design capabilities, the interfacing fuel, air, electrical, exhaust and plant heating control systems must be properly sized, selected, installed and tested. Additionally, all conditions must be such that the heat generated by the burner can be safely used or wasted without endangering personnel or equipment.
- It shall be the policy of John Zink Company, L.L.C. that no responsibility is assumed by the company nor any of its employees for any liability or damages caused by an inoperable, inadequate or unsafe burner condition which is the result, either directly or indirectly, of any of the improper or inadequate conditions described above.
- To insure that a safe and satisfactory installation has been made, a pre-start inspection is necessary. This inspection must be performed by an individual who is thoroughly familiar with all aspects of proper boiler/burner installation and how it interfaces with overall plant operation.
- Part I of this bulletin sets forth major inspection items that must be considered.

### NOTE

This inspection should be performed before the burner start-up specialist is called in. An incomplete or inadequate installation may require additional time and effort by start-up personnel and cause an untimely and costly delay.

- The results of this inspection will often times identify corrections that must be made prior to start-up as well as point out potential or long range problems in plant operation if corrections are not made.
- Burner start-up is a serious matter and should not be viewed as a time for “crowd gathering” by unconcerned, uninformed or unauthorized personnel. The number of persons present should be held to an absolute minimum.
- Instruction of operating and other concerned personnel should be done after the burner has been successfully fired and adjusted by a qualified service agency or factory start-up specialist.

# PART III

## BURNER FAMILIARIZATION AND PRELIMINARY INSPECTION

### BURNER FAMILIARIZATION

Study the following illustrations taking special note of the PART NAMES as shown in the call-outs.

Variations between systems are commonplace due to the many differences in job conditions and agency requirements.

This manual contains information applicable to a typical oil system arrangement and is not intended to be representative of any specific agency or code criteria.

### PRELIMINARY INSPECTION

The burner should be visually checked for damage and loose components as these conditions can occur during shipment, through improper handling, by tampering or through improper care and storage at the job site.

#### CHECK FOR:

- Obvious damage to housing, air inlet, and components mounted thereon.
- Tightness of fasteners, tube fittings, plugs, etc.
- Tightness of electrical terminals and connections.
- Tightness of adjustment mechanisms such as ball-joint swivel connectors and control arms.
- Accumulations of oil, dust, dirt, water or other foreign matter on, in, or near the burner.

# BURNER FAMILIARIZATION AND PRELIMINARY INSPECTION (continued)

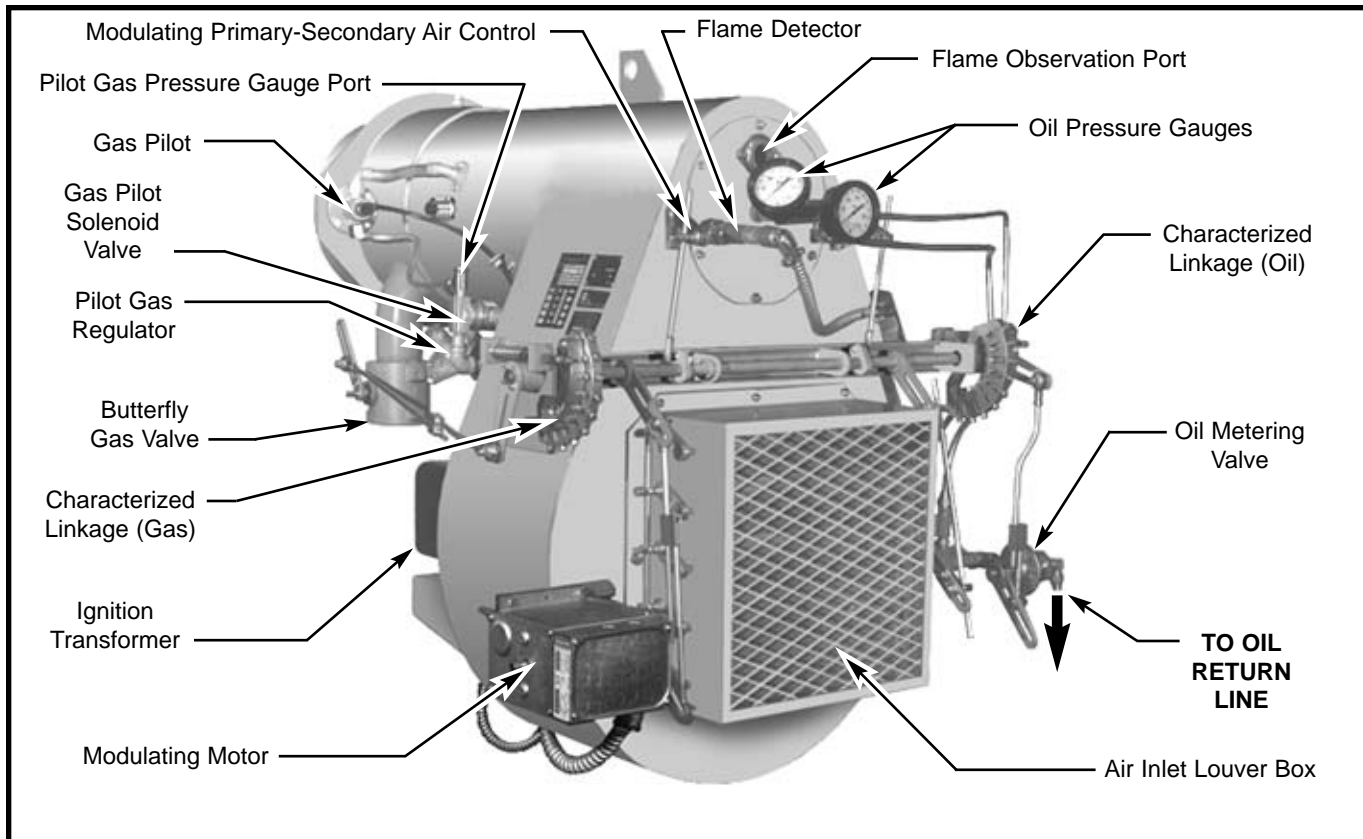

Figure 3-1 Back View, Typical Model F with GAS-OIL Systems

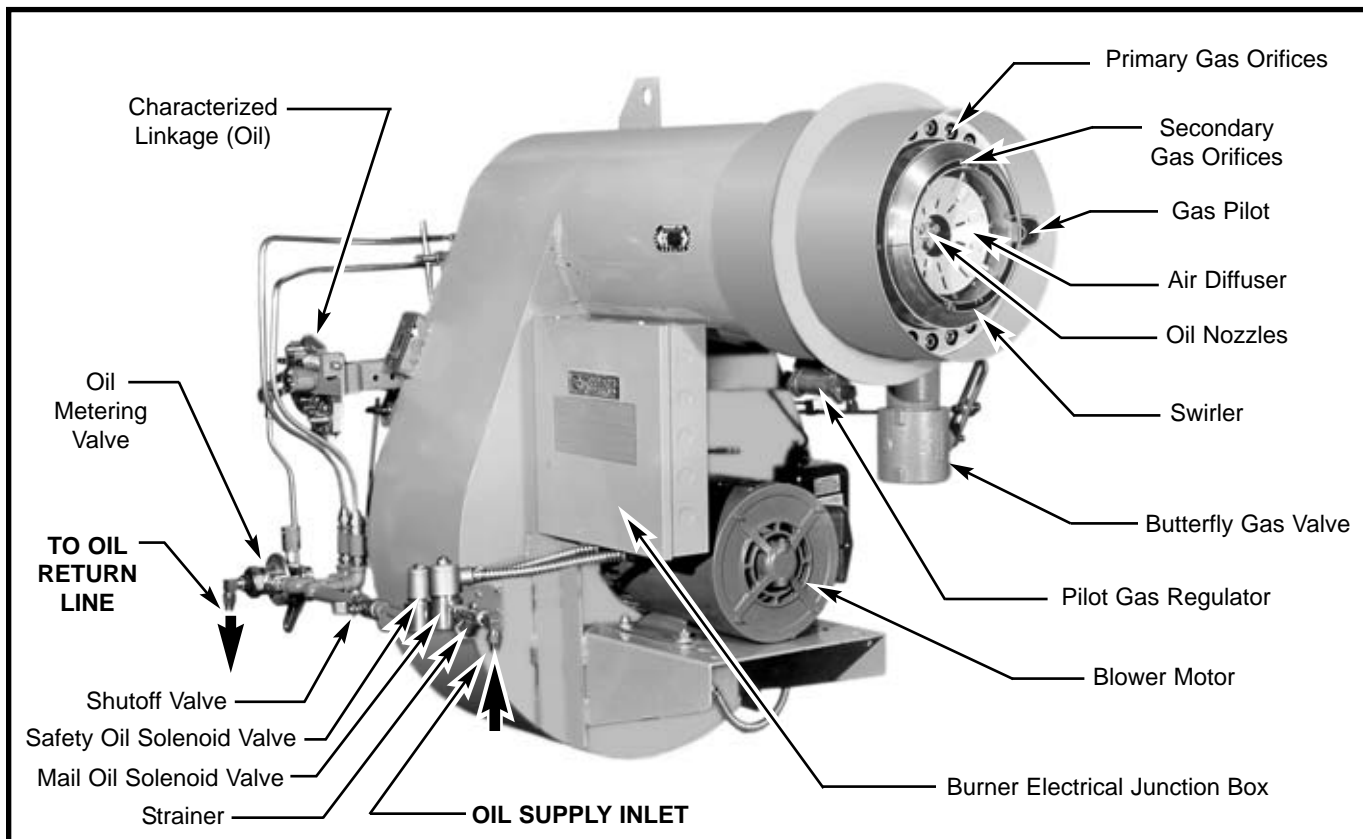

Figure 3-2 Front View, Typical Model F with GAS-OIL Systems

# PART IV

## SYSTEM DESCRIPTION

### NOTE

Please read through these instructions and refer to the separate data sheets before attempting to start the burner.

1. **GENERAL** - The following data is pertinent to the burner start-up and should be carefully studied before any attempt to start the burner is made. This material is a part of the instructions manual which accompanies the burner.

- Burner Material List
- Burner Wiring Diagram and Operating Sequence
- Flame Safeguard Bulletin
- Gas System Schematic (If applicable)  
(See 1-gen-10.50 for gas systems)
- Oil System Sheet (See 1-gen-80.8 for No. 2 oil systems and 1-gen-80.81 for No. 2 - 6 oil systems)
- Burner Identification and Numbering System  
(See 1-gen-10.1)
- Miscellaneous Manufacturer's Data on Controls, Valves, Regulators, etc.

### NOTE

The above cited manual is "One of a Kind" in that it contains material covering your specific burner. To replace it, considerable time, special handling, and significant costs are involved. Accordingly, it should be handled with care and kept in a location free of dust and moisture.

### WARNING!

Do NOT use teflon tape as an oil or gas pipe sealant. Teflon tape can cause valves to fail creating a safety hazard. Warranties are nullified and liability rests solely with the installer when teflon tape is used. Use a pipe joint compound rather than teflon tape.

2. **GAS PIPING INFORMATION** - The gas control size furnished and the minimum gas pressure required at the inlet to the controls is shown in the Burner Material List contained in the manual shipped with the burner.

Gas piping should be sized to provide the required minimum gas pressure at the main manual shutoff when operating at maximum input. Consult your local utility on any questions regarding gas pressure, piping pressure drops allowable and local piping requirements.

Gas piping should be installed in accordance with the American National Standard, ANSI Z223.1 and any other local codes which may apply. All gas piping should be tested after installation with air pressure or inert gas for at least three times the gas pressure that will be used. The piping ahead of the main manual shutoff shall include a full size dirt pocket or trap.

# E2 GAS SYSTEM

## Modulating, Proven Low Fire Start

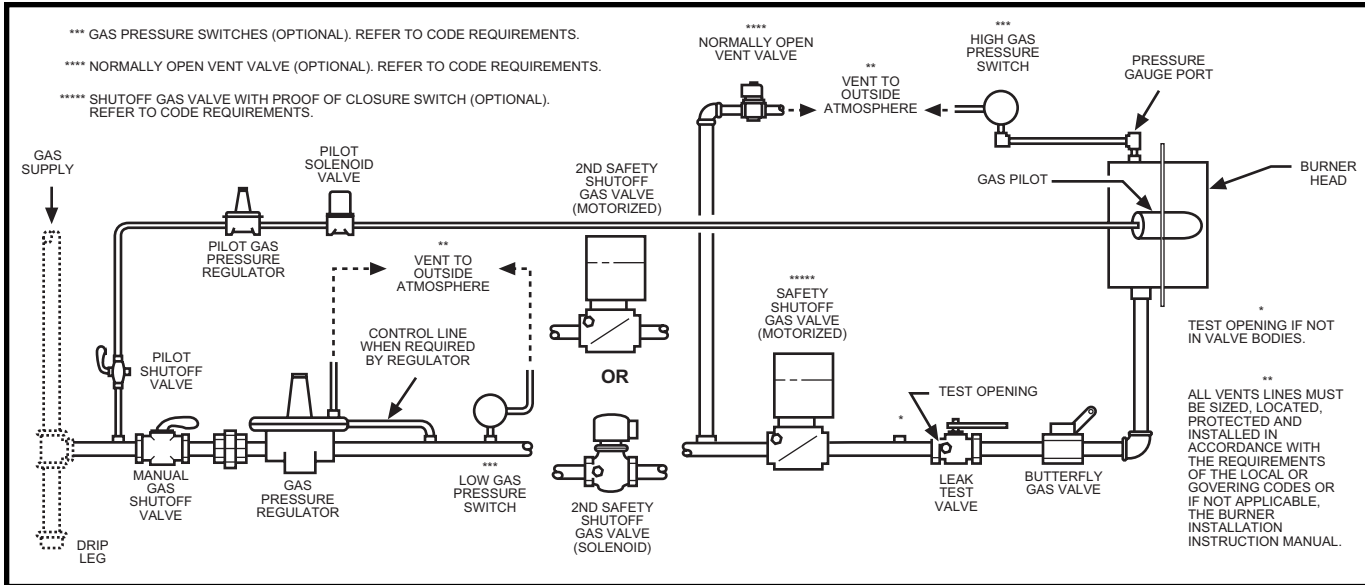

"E2" Gas System Schematic  
(As shown meets U.L. requirements)

**APPLICATION** - The "E2" gas system is used for modulation or high-low proven low fire start control in firing. It is commonly used on burners with 1,000 MBh to 35,000 MBh capacity and is used in conjunction with the "F7", "F7T", "F8", "F8H", "F9" and "F9H" oil systems for combination gas-oil models.

**DESCRIPTION** - The "E2" gas system uses motorized gas valves or quick opening solenoid gas valves and a modulating motor to provide a low fire and a high fire gas flow and simultaneously regulate the combustion air available to the burner. Gas pressure is adjusted and maintained by a pressure regulator. Head or orifice pressure is varied by a butterfly metering valve linked to the modulating motor. The gas butterfly metering valve is opened for high fire and gas is delivered to the orifices at the pressure setting of the pressure regulator. The air louver is also linked to the modulating motor, thus combustion air is increased proportionately as the orifice pressure increases.

**OPERATING SEQUENCE** - The burner motor starts on a call for heat by the operating control and the pre-purge cycle begins. At the end of pre-purge, the air louver must be in the closed (low fire) position for the low fire guarantee switch to close and allow ignition. Also, at the end of pre-purge, the ignition transformer is energized and the pilot valve opens, igniting the gas pilot.

The flame detector proves the flame and the safety shutoff gas valves open, supplying gas to the orifices at the low fire setting of the butterfly metering valve and the burner ignites at the low fire rate.

The ignition transformer and pilot valve are de-energized.

After a short delay, the modulating motor is switched to the control of a potentiometer or high-low controller, which drives the motor from the low fire position toward the high fire position to match the boiler load. Since both the air inlet louver and butterfly metering valve are linked to the modulating motor, the combustion air is increased proportionately as gas increases.

As the boiler load is overcome, the potentiometer or high-low controller drives the motor back toward the low fire position. On modulating units, the burner modulates over the range between low fire and high fire in response to the boiler load.

When the operating control is satisfied, the gas valves close and the burner motor is switched off, causing the burner to shut down and await the next call for heat.

3. **OIL SYSTEMS** - Refer to Figures 5-2 and 4-3 for basic piping diagrams. For detailed information, refer to the specific catalog sheets or drawings supplied with your burner.

### CAUTION

One of the most common oversights by an installer is failure to purge air, water, rust or other foreign matter from the oil system. **DAMAGE TO PUMPS AND OTHER COMPONENTS CAUSED BY RUST, WATER OR FOREIGN PARTICLES IS NOT COVERED BY WARRANTY.**

A standard method for purging is to remove the system pressure gauge (or plug where gauge would normally be installed) and temporarily install a piece of copper tubing long enough to drain into a bucket or other container. The pump motor starter contacts are then manually depressed with a piece of wood or other non-conductor device and the pump allowed to run until purging is complete. There must be no sign of air, water, rust or other foreign matter in the flow.

If flow is not established within 2 minutes, the pump should be primed through the suction line. Reinstall gauge or plug after purging is complete.

4. **LIGHT OIL** - If No.2 light oil is used, back off the back pressure regulating valve and oil pump relief valve to allow circulation at a few pounds pressure with all oil being returned to the tank. Run this way until entrained air is expelled than slowly build up the oil pressure in the circulating loop to 100 PSIG by tightening up the springs in these same valves.

### NOTE

The oil pump relief valve should be set to start opening at 5 to 10# above the setting of the back pressure regulating valve.

# F7 OIL SYSTEM

## Remote Burner Pump

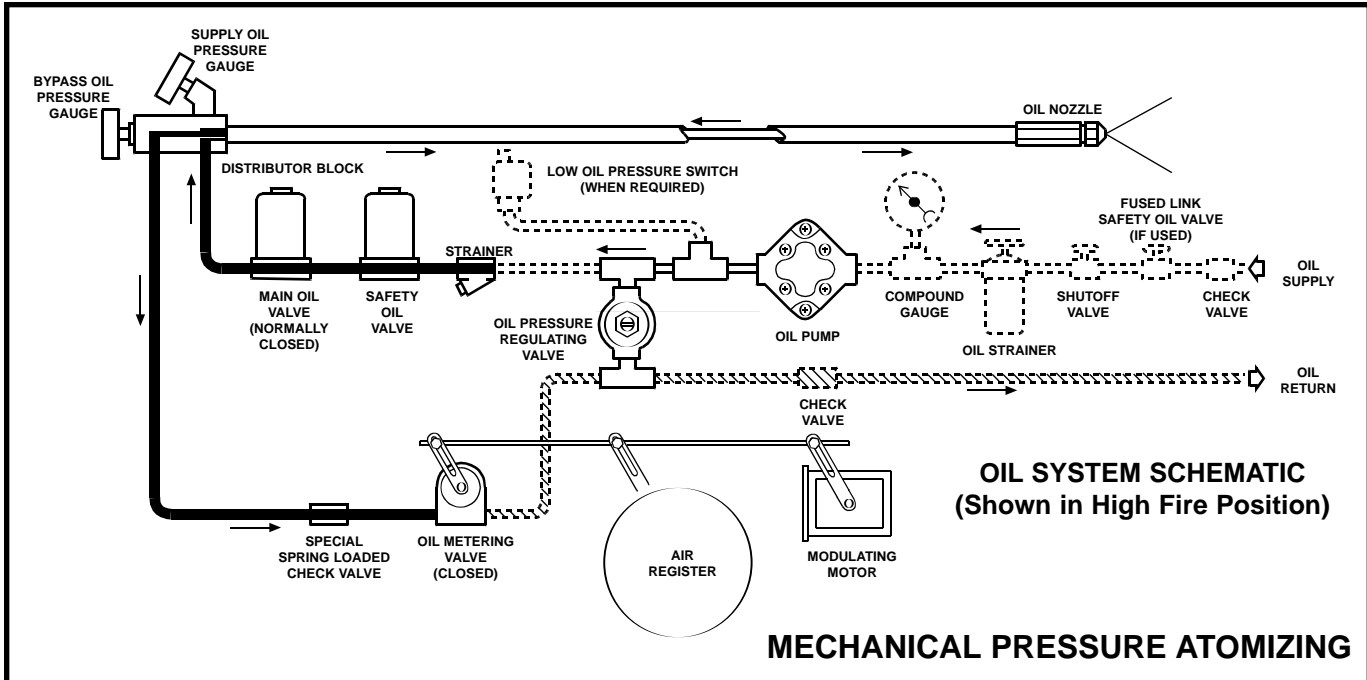

FIGURE 4-2 "F7" OIL SYSTEM SCHEMATIC

**APPLICATION** - The F7 Oil System is used for modulating or High-Low, Proven Low Fire Start Control in firing No. 2 fuel oil. It is commonly used on burners with 20 to 225 GPH capacity and is used in conjunction with the "E" gas system for combination gas-oil models.

**DESCRIPTION** - The F7 Oil System uses a bypassing type nozzle and a modulating motor to control the amount of oil available for atomization by the nozzle and simultaneously regulate the combustion air available to the burner. Pressure is generated by an oil pump connected to the burner motor through a flexible coupling or by a remote burner pump set located in close proximity to the burner. Pump pressure is adjusted and maintained by an oil pressure regulating valve. Oil flow through the nozzle is regulated by an oil metering valve in the bypass return line which is actuated by the modulating motor. The bypass return line is closed by the oil metering valve for high fire and all the oil delivered to the nozzle is atomized into the combustion chamber. The air louver is linked to the modulating motor, thus combustion air is increased proportionately as the oil firing rate increases. A spring loaded check valve prevents oil flow back through the nozzle during the burner OFF period.

**OPERATING SEQUENCE [Modulating Systems]** - The burner motor and pump start on a call for heat by the operating control and the pre-purge cycle begins.

The oil is returned to the tank through the pump or relief valve return line. The air louver returns to the closed [low fire] position and must remain there for the low fire guarantee switch to close and allow ignition at the end of pre-purge.

At the end of pre-purge, the gas pilot ignition transformer is energized, the gas pilot solenoid valve opens and the pilot ignites. After proof of pilot by the combustion control, the main and safety oil solenoid valves open supplying oil to the nozzle at the low fire pressure setting of the oil metering valve and the burner ignites at low fire rate.

At the end of the main flame trail for ignition, the gas pilot solenoid valve closes shutting off the gas pilot. After a short delay, the modulating motor is switched to the control of a potentiometer controller which drives the modulating motor from the low fire position toward high fire position to match the boiler load. With air louver and oil metering valve linked to the modulating motor, the combustion air is increased proportionately as the oil firing rate increases.

As the boiler load is overcome, the potentiometer controller drives the modulating motor back toward the low fire position and the burner modulates over the range between low fire and high fire in response to the boiler load.

# F7T OIL SYSTEM

## Remote Burner Pump

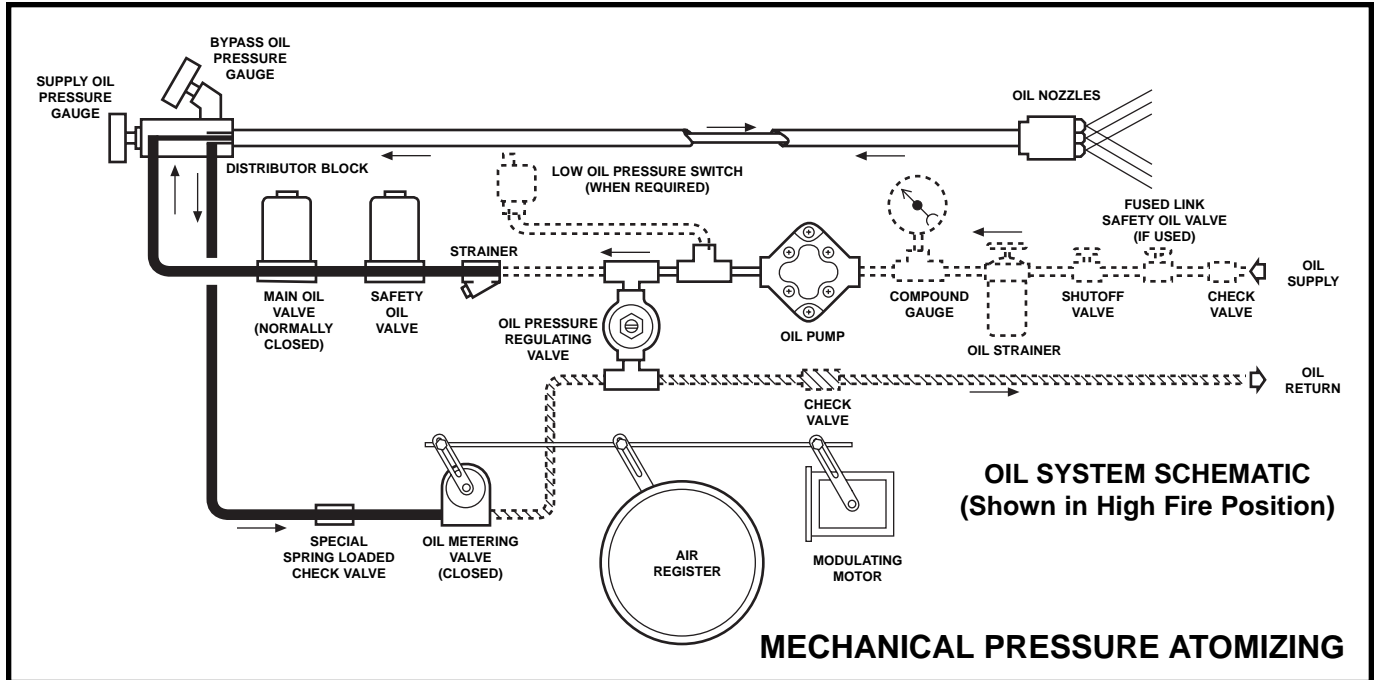

FIGURE 4-3 "F7T" OIL SYSTEM SCHEMATIC

**APPLICATION** - The F7T Oil System is used for modulating or High-Low, Proven Low Fire Start Control in firing No. 2 fuel oil. It is commonly used in conjunction with the "E" gas system for combination gas-oil models.

**DESCRIPTION** - The F7T Oil System uses bypassing type nozzles and a modulating motor to control the amount of oil available for atomization by the nozzles and simultaneously regulate the combustion air available to the burner. Pressure is generated by an oil pump connected to the burner motor through a flexible coupling or by a remote burner pump set located in close proximity to the burner. Pump pressure is adjusted and maintained by an oil pressure regulating valve. Oil flow through the nozzles is regulated by an oil metering valve in the bypass return line which is actuated by the modulating motor. The bypass return line is closed by the oil metering valve for high fire and all the oil delivered to the nozzles is atomized into the combustion chamber. The air louver is linked to the modulating motor, thus combustion air is increased proportionately as the oil firing rate increases. A spring loaded check valve prevents oil flow back through the nozzle during the burner OFF period.

**OPERATING SEQUENCE [Modulating Systems]** - The burner motor and pump start on a call for heat by the operating control and the pre-purge cycle begins.

The oil is returned to the tank through the pump or relief valve return line. The air louver returns to the closed [low fire] position and must remain there for the low fire guarantee switch to close and allow ignition at the end of pre-purge.

At the end of pre-purge, the gas pilot ignition transformer is energized, the gas pilot solenoid valve opens and the pilot ignites. After proof of pilot by the combustion control, the main and safety oil solenoid valves open supplying oil to the nozzles at the low fire pressure setting of the oil metering valve and the burner ignites at low fire rate.

At the end of the main flame trail for ignition, the gas pilot solenoid valve closes, shutting off the gas pilot. After a short delay, the modulating motor is switched to the control of a potentiometer controller which drives the modulating motor from the low fire position toward high fire position to match the boiler load. With air louver and oil metering valve linked to the modulating motor, the combustion air is increased proportionately as the oil firing rate increases.

As the boiler load is overcome, the potentiometer controller drives the modulating motor back toward the low fire position and the burner modulates over the range between low fire and high fire in response to the boiler load.

# PART V

## PRELIMINARY ADJUSTMENTS

1. **FACTORY ADJUSTMENTS** - The burner is adjusted at the factory to meet “dry run” conditions. Adjustments and initial settings must be checked prior to initial light-off and settings must be verified by combustion tests.

Depending on the model and capacity of the burner, various adjustment mechanisms control the air and fuel available for combustion, while others control the safe and reliable function of the gas-electric ignitor.

2. **ADJUSTMENT MECHANISMS** - Illustrations which follow show the items which are subject to adjustment. Determine the applicability of each illustration to your burner, then proceed to familiarize yourself with the function of the item. Where a setting is indicated, verify the setting or make preliminary adjustments as necessary to facilitate initial start-up.

**WARNING!**

Adjustable air and fuel control mechanisms which modulate with the burner firing rate must be adjusted with the 0 to 90° actuator in the 0° position.

# BURNER AIR AND FUEL ADJUSTMENTS

## Items 1 through 13

### ITEM 1

#### ADJUSTMENT OF PRIMARY-SECONDARY AIR CYLINDER

**DESCRIPTION** - A separate air adjustment at the firing head provides a unique air control system enabling quiet, stable combustion without objectional noise or pulsation. This feature allows flexibility in adapting to a variety of job conditions and insures greater combustion efficiency.

**HOW IT WORKS** - See Figures 5-1 and 5-1A. Moving the position of the knobs forward reduces the amount of air available for combustion while movement to the rear increases the air supply. There are two versions of this mechanism.

1. Manually set and locked into position.
2. Automatic - Proportions the air at the firing head as the combustion control programs (modulates) the burner to meet the boiler load.

#### Primary-Secondary Air Cylinder Manually Set and Locked

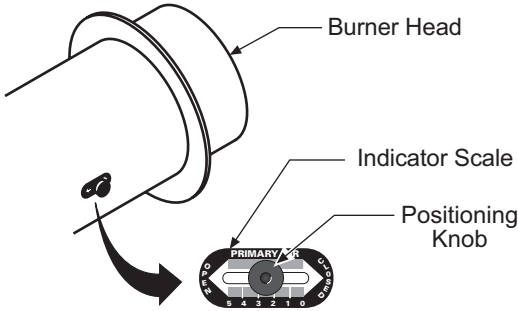

Labels: Burner Head, Indicator Scale, Positioning Knob

#### ADJUSTMENT PROCEDURE

1. Loosen positioning knobs.
2. For initial start-up, position knobs at 1.25 in the adjustment slot, then tighten against indicator scale.

**NOTE** If positioned too far forward, the main flame may pulsate. If too far to the rear, the surplus air may cause noisy operation.

Figure 5-1 Adjustment of Manual Proportioning Primary-Secondary Air Control

#### Primary-Secondary Air Cylinder Automatic Positioning

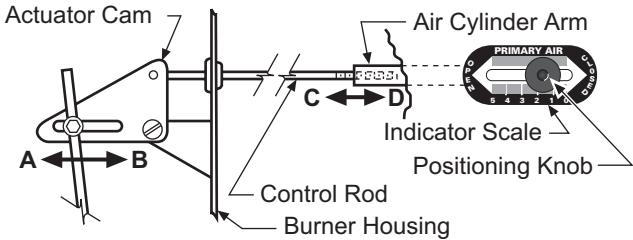

Labels: Actuator Cam, Air Cylinder Arm, Indicator Scale, Positioning Knob, Control Rod, Burner Housing

A = Shortens travel of primary air sleeve.  
B = Lengthens travel of primary air sleeve.  
C = Increases air to primary gas orifices.  
D = Reduces air to primary gas orifices.

**CAUTION** Knobs must be free to travel in horizontal slots when burner modulates.

#### ADJUSTMENT PROCEDURE

This mechanism has two controlling adjustments:

1. The actuator cam is slotted to allow positioning of the drive rod to obtain the desired travel.
2. The control rods are threaded into the air cylinder arms allowing the working length to be shortened or lengthened as required. This is accomplished by removing the actuator cams, then screwing the control rods in-or-out to obtain the desired length.
3. For initial start-up, the position indicator knobs should be at approximately position 0.5 on the indicator scale. Cams should be adjusted to provide travel to position 3-3.5 at high fire.

Figure 5-1A Adjustment of Automatic Proportioning Primary-Secondary Air Control

## BURNER AIR AND FUEL ADJUSTMENTS (continued)

### ITEM 2 ADJUSTMENT OF AIR INLET LOUVER BOX

**DESCRIPTION** - The amount of air available for combustion is controlled by adjustable louvers located in the air box. The louvers are interconnected through a series of small linkage arms secured to a common drive rod.

**HOW IT WORKS** - See Figure 5-2. Louver opening and travel is controlled by adjusting the linkage mechanism from the actuator to obtain the desired opening and stroke. The actuator drives the louvers open or closed as the combustion control programs the burner firing rate to meet the boiler load.

#### Air Inlet Louver Box

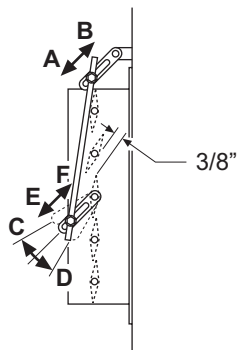
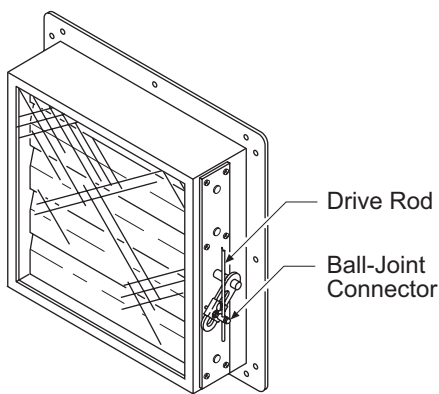

#### METHOD I

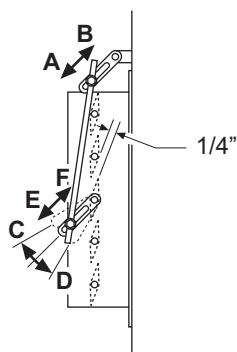

#### METHOD II

#### ADJUSTMENT PROCEDURE

##### METHOD I (High Turndown)

1. Use box end or socket wrench to loosen ball-joint connector.
2. To adjust low fire (minimum) air setting, loosen ball-joint connector holding drive rod and manually close all louvers.
3. Retighten ball-joint connector.
4. With a 3/32" Allen wrench loosen the set screws on the second from the top louver. Set the louver 3/8" open and tighten set screws.

##### METHOD II (Medium Turndown)

1. Use box end or socket wrench to loosen ball-joint connector.
2. To adjust low fire (minimum) air setting, loosen ball-joint connector holding drive rod and manually position louvers to obtain the desired opening, then retighten connector.
3. For initial start-up; position air inlet louvers so they are approximately 1/4" open.

#### NOTE

To adjust amount of travel (stroke), loosen base of ball-joint connector located in slotted (louver) actuator arm and reposition to desired setting, then re-tighten connector.

- A = Increases louver opening
- B = Reduces louver opening
- C = Slows opening of louver first 1" of travel
- D = Quickens opening of louver first 1" of travel
- E = Reduces louver opening
- F = Increases louver opening.

Figure 5-2 Adjustment of Air Inlet Louver Box

## BURNER AIR AND FUEL ADJUSTMENTS (continued)

### ITEM 3

 ADJUSTMENT OF GAS PILOT IGNITOR ASSEMBLY

**DESCRIPTION** - The gas pilot ignitor is basically composed of:

1. An ignition electrode with insulator which generates an arc between it and the adjacent ground.
2. A fuel tube through which the gas is directed to the point of the electrical arc.

**HOW IT WORKS** - See Figures 5-3A and 5-3B. A charge from a high voltage transformer is routed to the ignition electrode causing an intense arc to ground. The electrode is then immersed in a concentration of gas as the pilot solenoid valve opens allowing flow to the pilot. The arc ignites the gas, the electrical discharge from the transformer terminates and the pilot stands ready to ignite the main burner flame.

#### Gas Pilot Ignitor Assembly

PILOT GAS ORIFICE CHART		
GAS	ORIFICE PART NO.	DIA.
NAT.	-----	.2130
L.P.	230012-0154	.1540
NAT.	230012-0125	.1250
L.P.	230012-0094	.0935
NAT.	230012-0108	.1065
L.P.	230012-0070	.0700
NAT.	230012-0078	.0781
NAT.	230012-0073	.0730

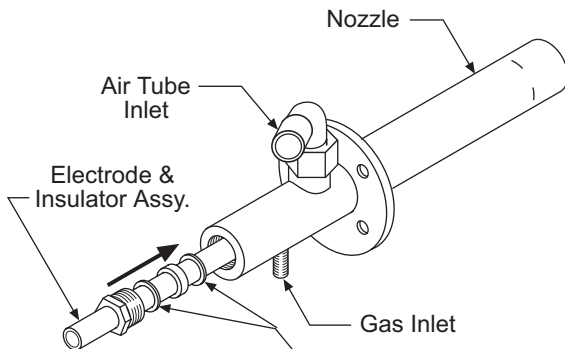

#### NOTE

Always install copper gasket with flat side to insulator.

#### NOTE

When viewing pilot flame, gas should be burning on full face of pilot insert.

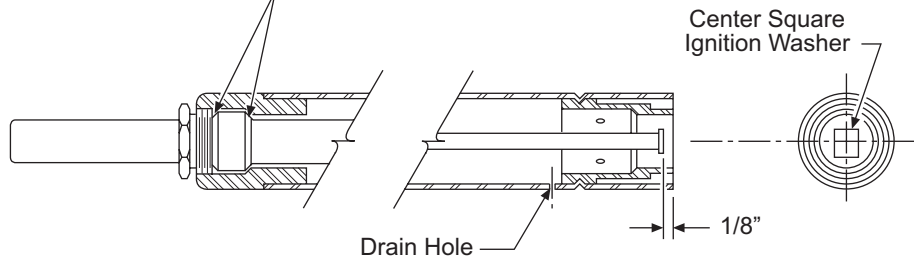

#### ADJUSTMENT PROCEDURE

#### NOTE

The gas pilot ignitor assembly is a vital part of the burner and must be kept clean and properly adjusted at all times.

#### WARNING!

Turn off all electrical disconnects to the burner and any other equipment or systems electrically interlocked with the burner. Turn off the manual pilot gas valve.

1. Disconnect cables, lines or tubes from the ignitor assembly and remove from burner housing.
2. Inspect square ignition washer for cleanliness and proper adjustment as shown.
3. Remove ignition electrode assembly and check insulator for cleanliness and/or cracks.
4. Burnish end of electrode tip and insert of pilot tube assembly with a battery terminal cleaner or similar device.
5. Reinstall ignition electrode assembly and check that square ignition washer is approximately centered in pilot assembly. If not, loosen electrode locking nut and rotate assembly and tighten nut.
6. Reinstall pilot assembly in burner.

**Figure 5-3A Adjustment of Gas Pilot Ignitor Assembly**

## BURNER AIR AND FUEL ADJUSTMENTS (continued)

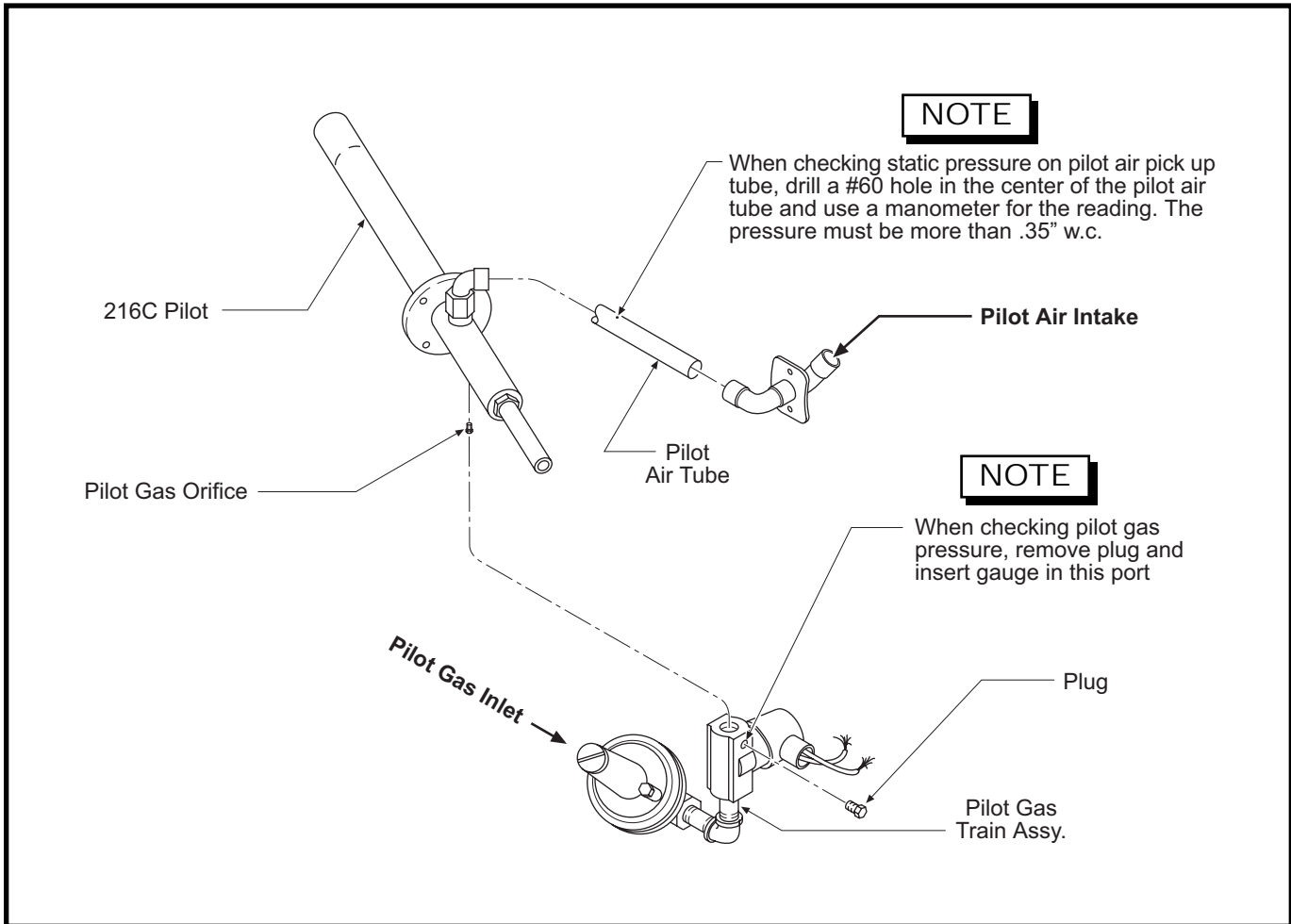

Figure 5-3B Adjustment of Gas Pilot Ignitor Assembly

**BURNER AIR AND FUEL ADJUSTMENTS (continued)**  
**PILOT TROUBLE SHOOTING**

<b>TROUBLE</b>	<b>PROBABLE CAUSE</b>	<b>ACTION</b>
Motor runs but ignition spark does not occur.	Ignition cable or electrode loose or grounded.	Check to insure that ignition cable is securely plugged into electrode. Check cable and clean if necessary.
		Remove and check electrode insulator for cracks.
	Pilot ignition transformer defective.	Check for 120 volts on ignition transformer panel terminal. Replace transformer if required.
	Defective flame safeguard.	Check voltage on ignition terminal. Replace flame safeguard if required.
Motor runs, ignition occurs, but gas does not ignite.	Carbon hair on ignition electrode to ground.	Carefully remove pilot assembly and check for carbon hair. Remove, clean pilot assembly and ignition electrode, re-install and re-adjust pilot gas pressure for a leaner burning pilot.
	No gas being supplied to pilot.	Check the manual pilot gas valve to insure that it is open.
		Make sure gas line has been purged of air.
		Pilot orifice plugged, clean.
	Gas pilot regulator locked up. Check inlet gas supply pressure. Replace gas pilot regulator.	
	Pilot gas valve does not open.	Check for 120 volts to coil. Check valve action by sound and feel. Replace coil or valve body as needed.
Motor runs, gas pilot establishes, pilot flame does not prove.	Improper gas flow.	Increase or decrease gas pressure to pilot.
	Flame sensor dirty.	Clean or replace sensor.
	Flame sensor cannot see pilot.	Look down thru sight tube. If unable to get clear view of pilot, correct problem.
	Improper ground circuit.	Check voltage on neutral wire to panel ground. Voltage must not be more than .5 volts.
	Pilot air supply incorrect.	Check static pressure on pilot air pick up tube. Must be more than .35" w.c. pressure. Open low fire air setting more.

## BURNER AIR AND FUEL ADJUSTMENTS (continued)

### ITEM 4 ADJUSTMENT OF BUTTERFLY GAS VALVE

**DESCRIPTION** - The butterfly gas valve is a fuel throttling device which proportions the gas in proper ratio to the combustion air. The valve is opened or closed by an actuator as the combustion control programs the burner firing rate to meet the boiler load.

**HOW IT WORKS** - See Figure 5-4. A centrally located disc turns within a cylindrical body which regulates the gas flow to the main burner flame. The butterfly valves used are the non-tight shutoff type.

Through a linkage system, an actuator drives the valve open or closed in response to electrical signals from the combustion control. Since the amount of air available for combustion is controlled by the same actuator, a proper fuel-air ratio is maintained at all times.

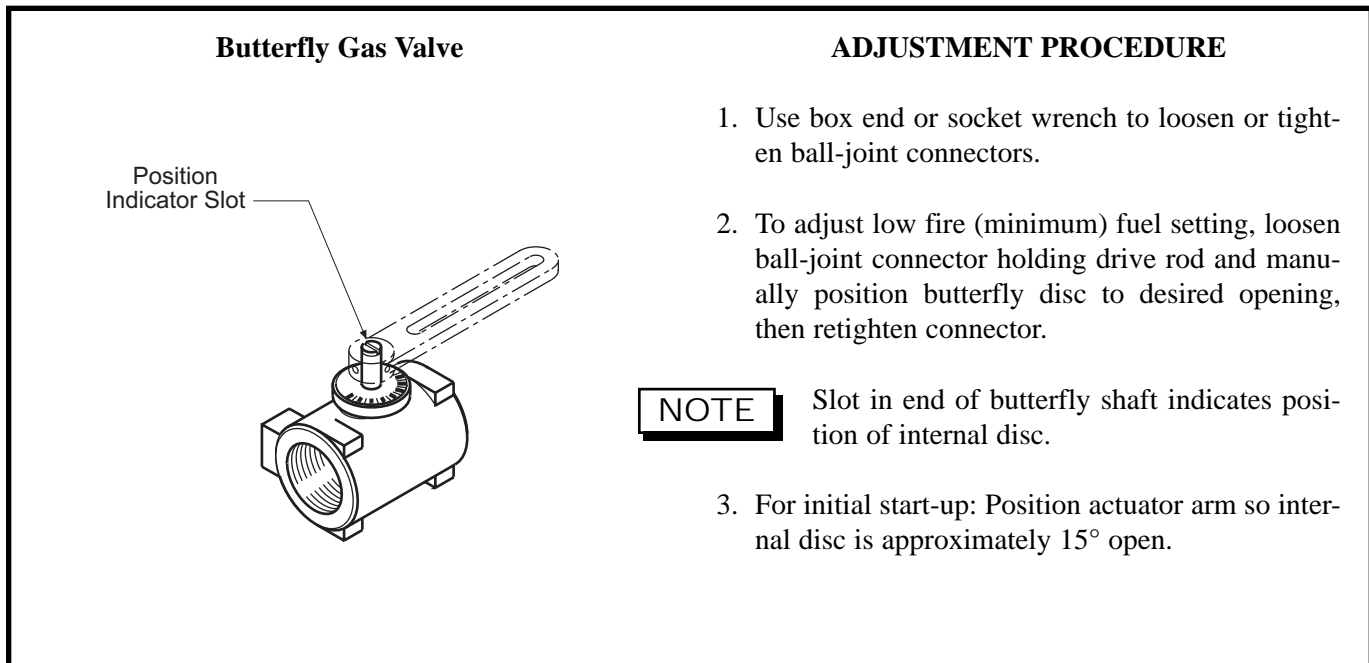

Figure 5-4 Adjustment of Butterfly Gas Valve

## BURNER AIR AND FUEL ADJUSTMENTS (continued)

### ITEM 5 ADJUSTMENT OF GAS PRESSURE REGULATORS

**DESCRIPTION** - Gas burners have two gas pressure regulators, one to regulate the pressure to the main flame and the other to regulate the gas pilot ignitor. Most model F and FL oil burners use gas pilot ignition; therefore, the gas pressure regulator is common to most all F and FL burners.

**HOW IT WORKS** - See Figure 5-5. Simply stated, gas flow is controlled by a spring of known load range which works against the supply (from the meter) gas pressure. Accordingly, each regulator must be fitted with the right spring for it to function properly. Additionally, the tension on the regulator spring must be adjusted to obtain the exact gas pressure required at the inlet to the controls.

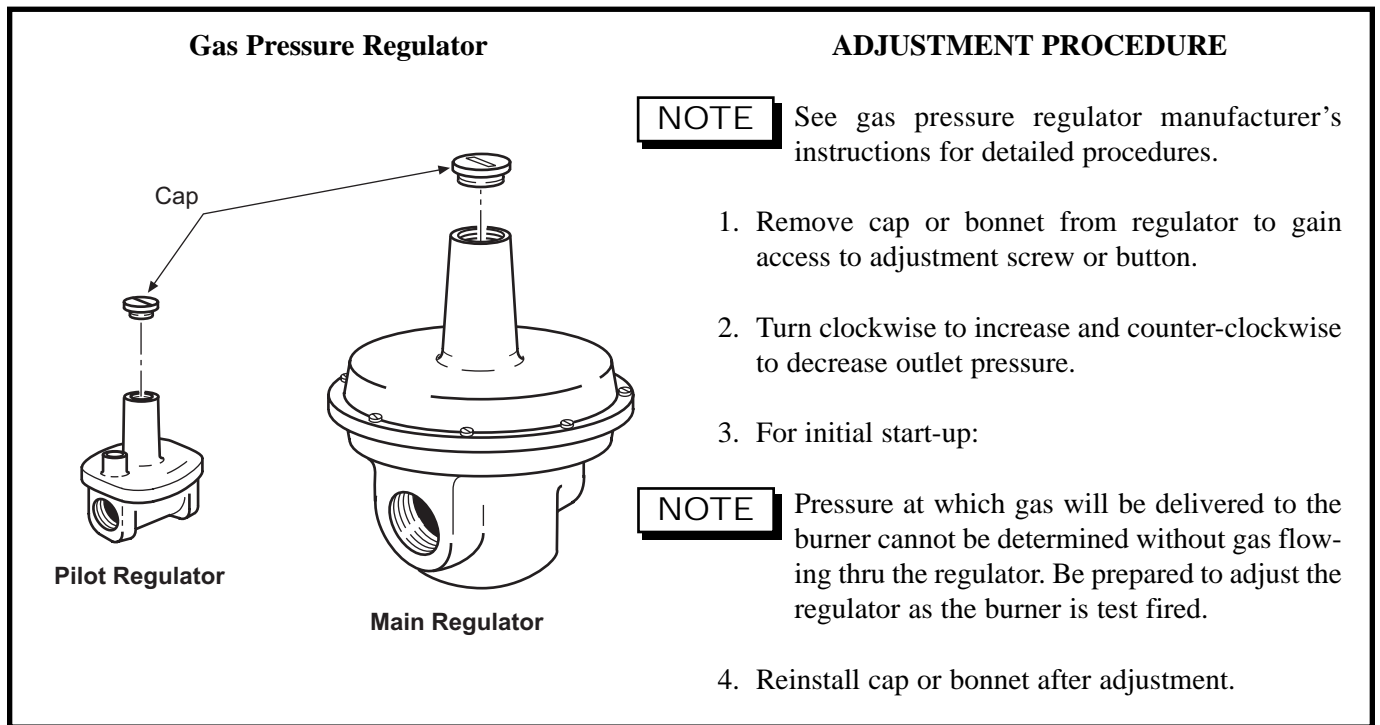

## BURNER AIR AND FUEL ADJUSTMENTS (continued)

### ITEM 6 ADJUSTMENT OF GAS PRESSURE SWITCHES

**DESCRIPTION** - Gas pressure switches are pressure-actuated electrical switching devices designed for safety shutoff when gas pressures are either too low or too high.

**HOW IT WORKS** - See Figure 5-6. The pressure switch senses any change in gas pressure and, if properly adjusted, will transmit an electrical signal to the automatic shutoff valve and/or other interlocking devices when an unsafe condition exists. The burner will then re-cycle or completely shut down depending upon the flame safeguard used. Gas pressure switches are designed to operate over a specified pressure range; therefore, each switch must be selected to be compatible with the burner operating gas pressure and also to obtain the desired electrical features.

Gas Pressure Switch	ADJUSTMENT PROCEDURE
	<p data-bbox="699 793 1404 934"><b>NOTE</b> See gas pressure switch manufacturer's instructions for detailed procedures. Units with mercury switching device must be properly leveled.</p> <ol data-bbox="776 972 1404 1281" style="list-style-type: none"><li>1. For initial start-up:<ol data-bbox="815 1041 1404 1281" style="list-style-type: none"><li>a. Low Gas Pressure Switch - Adjust to a lower pressure than that to be experienced for normal operation to allow the burner to be set up.</li><li>b. High Gas Pressure Switch - Adjust to a higher pressure than that to be experienced for normal operation to allow the burner to be set up.</li></ol></li></ol> <p data-bbox="699 1318 1404 1417"><b>NOTE</b> Final adjustment must be done after the burner has been test fired. See burner start-up procedures.</p>

Figure 5-6 Adjustment of Gas Pressure Switches

### ITEM 7 ADJUSTMENT OF OIL DRAWER ASSEMBLY

**DESCRIPTION** - Oil burners have an assembly made up of vital oil and air handling components known as the "Oil Drawer Assembly". Basically, this assembly contains the oil tubes, the atomizing nozzle(s), the air diffuser with mounting bracket and an oil distributor block and backplate which secures the unit to the burner housing. If the burner has direct spark oil ignition, the ignition electrodes are also a part of this assembly.

**HOW IT WORKS** - See Figure 5-7, 5-7A and 5-7B. The oil is forced down the supply tube under high pressure and is atomized into the combustion chamber by the oil nozzle. The air diffuser distributes the combustion air through the atomized oil which is then ignited by the gas pilot ignitor or by an electrical spark if burner has direct spark ignition. On bypassing oil nozzle systems, the excess oil is diverted from the nozzle to the bypass return line.

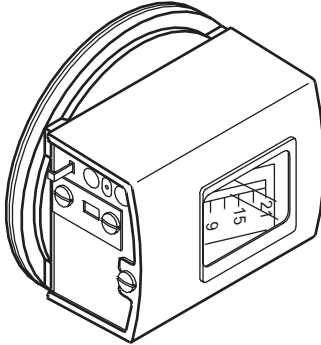
## BURNER AIR AND FUEL ADJUSTMENTS (continued)

### Oil Drawer Assembly without Quick Draw Oil Gun Feature (Typical)

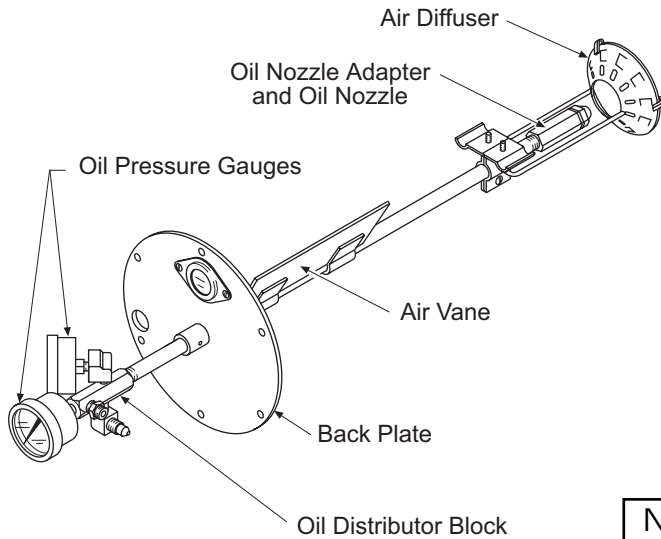

#### NOTE

### ADJUSTMENT PROCEDURE

Adjusting the relationship between air diffuser and oil nozzle requires removal of the oil drawer from the burner.

The relationship between the air diffuser - oil nozzle and the inner fire cylinder may be adjusted in the following manner.

1. At back of burner, use Allen wrench to loosen set screw in collar thru which oil pipe protrudes.
2. Grasp oil distributor block and move oil drawer assembly in or out to obtain desired position, then re-tighten set screw loosened in Step 1 above.
3. For initial startup:

#### NOTE

Adjustment requirements cannot be finally established until after the burner is fired, The dimensions shown in Figure 5-7A will normally prove acceptable for start-up.

### Oil Drawer Assembly with Quick Draw Oil Gun Feature (Typical)

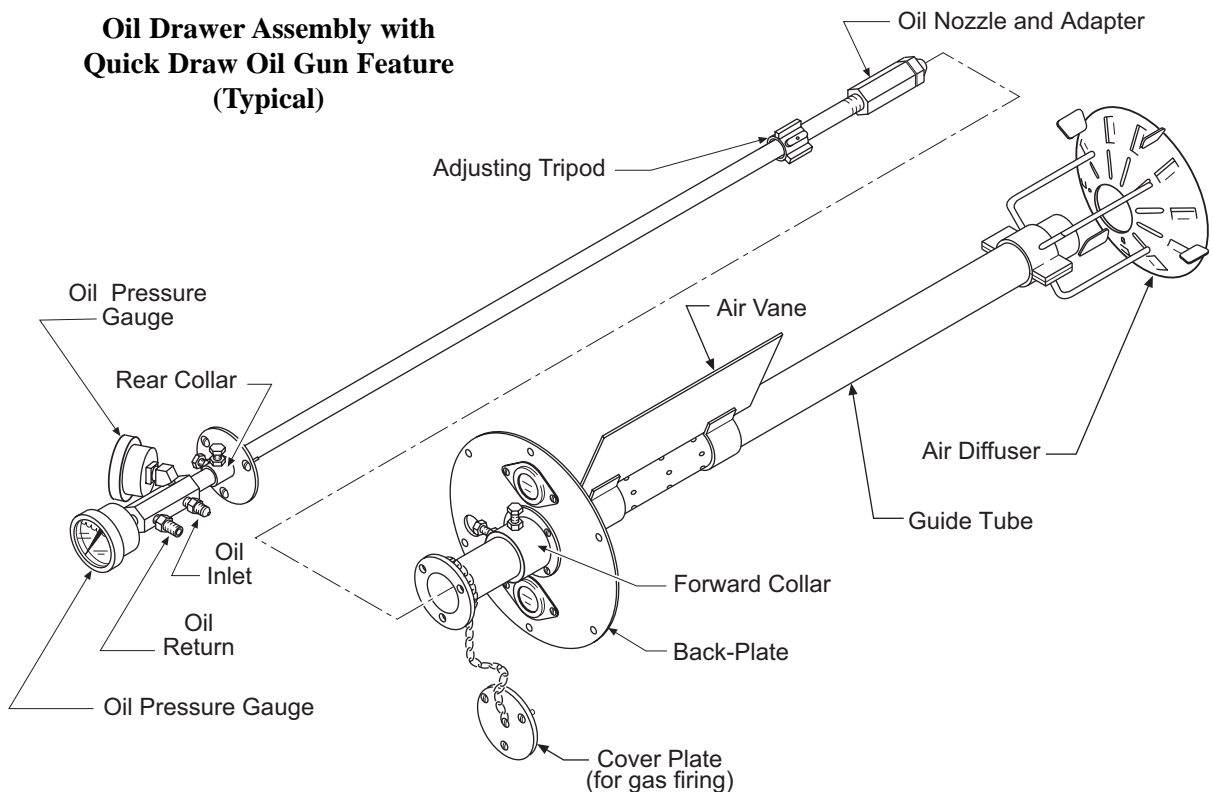
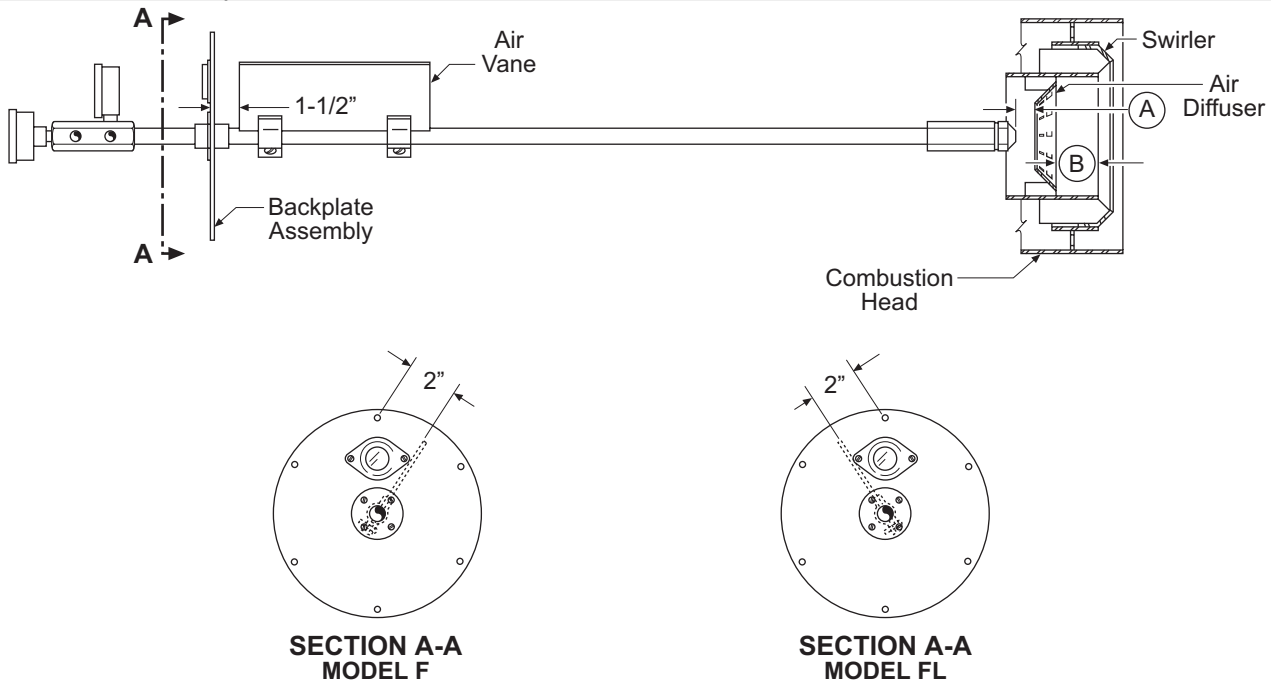

Figure 5-7 Adjustment of Oil Drawer Assembly

## BURNER AIR AND FUEL ADJUSTMENTS (continued)

BURNER MODEL		OIL DRAWER ASSEMBLY ADJUSTMENTS						
		DIFFUSER CENTER HOLE DIAMETER (Inches)	NOZZLE SPRAY ANGLE	BOILER TYPE	DIMENSIONS (Inches)		B	
					OIL SYSTEM			
F	FL				F7	F7T		
X	X	1-13/16	60°	Firebox	3/4	NA	1-1/2	
			90°		7/16			
		2-1/16	60°		7/8	3/8		
			90°		9/16	1/4		
		2-1/4	60°		1-1/4	7/16		
			90°		3/4	1/4		
		2-3/4	60°		1-1/2	1		
			90°		1	1/2		
		1-13/16	60°		Scotch	3/4		NA
			90°			7/16		
		2-1/16	60°			7/8		3/8
			90°			9/16		1/4
		2-1/4	60°			1-1/4		7/16
			90°			3/4		1/4
		2-3/4	60°			1-1/2		1
			90°			1		1/2



**NOTE** Regardless of dimensions shown, there should be **NO IMPINGEMENT** of the oil on the ignition electrodes or air diffuser.

Manufacturing tolerances in both the nozzle and the oil drawer assembly may cause variations in the above dimensions.

It is recommended that after all adjustments have been made and the burner has been test fired that the oil drawer assembly be removed and examined for wetting or excessive carbon build-up. Evidence of these conditions requires re-adjustment.

**Figure 5-7A Adjustment of Oil Drawer Assembly**

## BURNER AIR AND FUEL ADJUSTMENTS (continued)

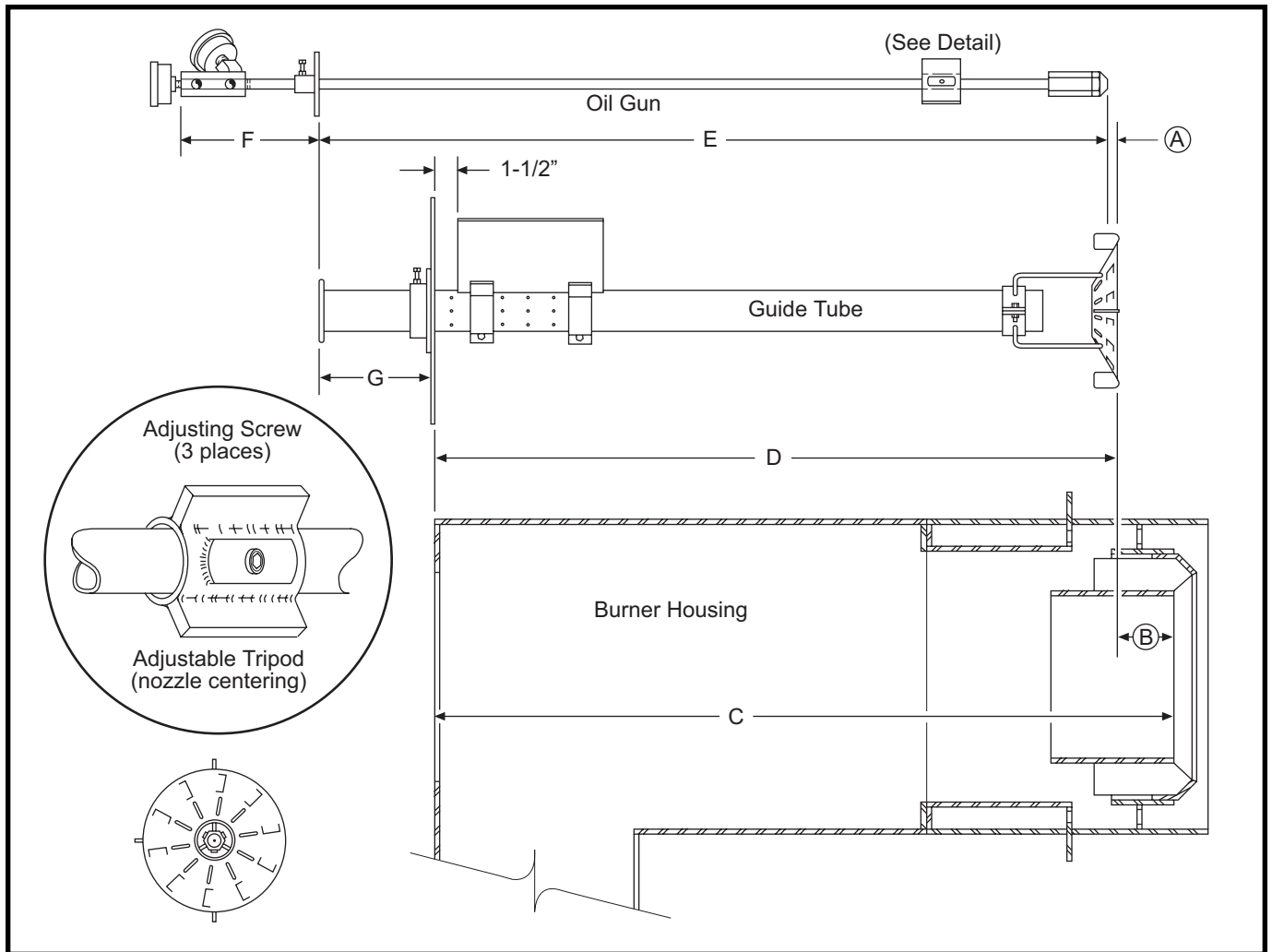

Figure 5-7B Dimensioning Detail and Oil Drawer Assembly with Quick Draw Oil Gun

### ADJUSTMENT PROCEDURE - Oil Drawer Assembly with Quick Draw Oil Gun

Making accurate settings for the guide tube oil drawer assembly requires removal of the entire assembly from the burner housing.

REMOVAL: (See Figure 5-7)

1. Tighten set screws in forward and rear collars to hold guide tube and oil gun securely in position.
2. Disengage fittings on oil supply and return lines.
3. Unscrew flame scanner and its adapter from end of sight tube.
4. Unscrew the nuts holding drawer assembly back-plate to burner housing.

### CAUTION

In the following-step, do not permit front end of drawer assembly to fall as the diffuser slides out of swirler cylinder. Support rods, diffuser cone and diffuser spacers may be bent, requiring repair or possible replacement.

5. Pull straight back on drawer assembly until back-plate clears the mounting studs.

Lower the rear end of the drawer slightly to provide sufficient clearance for the air vane to pass through the opening in the burner housing and slowly continue to pull the drawer back.

When an adequate gap exists between back-plate and burner housing, reach inside and support guide tube with the other hand. Drawer assembly may now be withdrawn fully.

## BURNER AIR AND FUEL ADJUSTMENTS (continued)

ADJUSTMENT: (See Figure 5-7b)

1. Set oil drawer assembly on a flat surface.
2. Using Figure 5-7A, determine the the value of dimension **(A)**, then check for this dimension. If adjustment is necessary, loosen set screws in rear collar and slide oil gun in or out as required, then re-tighten set screws.
3. Determine the value of dimension **(B)**, then check for this dimension. If adjustment is necessary, refer to Figure 5-7B and measure to obtain dimensions C and D. The **(B)** dimension is the difference between dimensions C and D.

Loosen back-plate (forward) collar set screws and slide back-plate back or forward as required to obtain the correct value for dimension **(B)**; then re-tighten set screws.

Make certain the air vane is located properly in relation to the back-plate. (See Figure 5-7A). This can be changed by loosening the two clamp screws that secure the vane to the guide tube, re-positioning the vane, then re-tightening the screws.

See Figure 5-7A, check concentricity of air diffuser center hole with oil nozzle by measuring from nozzle body (or nozzle adapter) to inside of hole at three or four equidistant points.

If nozzle is off-center, check tightness of air diffuser clamp screws, and tighten if necessary.

If eccentricity persists, pull the oil gun from the guide tube as follows:

- a. Annotate the relationship of the oil nozzle to the center hole and the orientation of the fittings to the back-plate.
- b. Using a large flat bladed screw driver, rotate the three “quarter turn” fasteners on the oil gun flange 90° CCW to disengage them. The studs are held captive to the flange by washers.
- c. Carefully remove the oil gun straight out and place on a flat surface.

Note that the oil gun is centered in the guide tube by an adjustable tripod which is positioned and held in place by three screws.

Loosen and tighten the three adjusting screws as necessary to obtain the desired positioning, then check for nozzle concentricity by re-installing the oil gun in the guide tube, making sure the fittings are properly oriented with the back-plate. Repeat procedure until concentricity is obtained, then secure the oil gun with the three “quarter turn” fasteners.

5. Re-install the complete oil drawer assembly in the burner.

## BURNER AIR AND FUEL ADJUSTMENTS (continued)

### ITEM 8 ADJUSTMENT OF OIL METERING VALVE

**DESCRIPTION** - Oil burners which have low fire start fuel control systems must deliver oil to the nozzle at reduced pressure for low fire. This is normally accomplished by diverting a portion of the oil pump delivery thru a bypass return line to the tank.

The amount of oil delivered to the nozzle versus that returned to the tank is controlled by a device which limits or meters flow, thus an oil metering valve is commonly used for this purpose.

**HOW IT WORKS** - Most oil metering devices work on the principle of limiting flow by constricting the area thru which the oil must pass. In order to vary the orifice area, mechanical movement must take place, thus the oil metering valve requires an actuator to do its job. By interconnecting a common actuator to the combustion air control and the oil metering valve, this allows the fuel (oil) to be proportioned in precise ratio to the amount of air available for combustion, This feature is essential on modulating type fuel control systems.

#### Oil Metering Valve

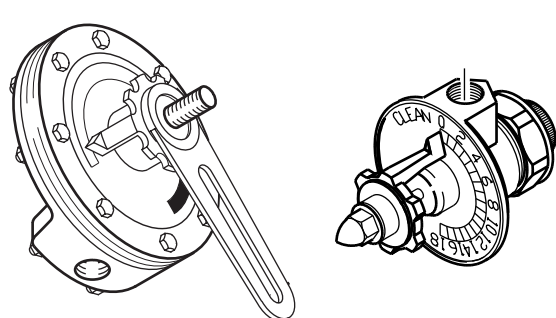

(Typical)

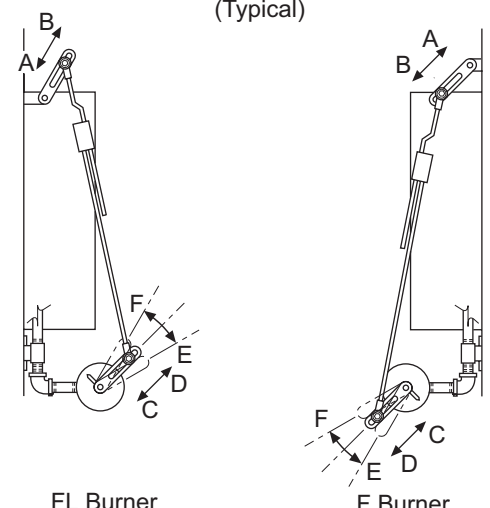

FL Burner                      F Burner

TYPICAL F7 OR F7T OIL SYSTEM

#### ADJUSTMENT PROCEDURE

**NOTE** Valves vary by the amount of rotation required to cover the full range of regulation. Most valves will have a range of regulation. Most valves will have a range from 0° to 90° or 0° to 120°. The maximum travel that can be realized from a 90° actuator and mechanical linkage arrangement is about 120°. The amount of travel to be used is dependent upon the required turn-down ratio (flow rates) between high-fire and low-fire and the flow characteristics of the particular valve.

For initial start-up: (use factory set points)

**NOTE** Adjustment requirements cannot be finally established until after the burner is fired. The valve should work from a mid-open to a closed position when located in the return line when going from low-fire to high-fire.

**NOTE** To adjust amount of travel, loosen base of ball-joint connector located in slotted actuator arm and reposition to desired setting, then re-tighten connector.

- A = Decrease travel of metering valve
- B = Increase travel of metering valve
- C = Increase travel of metering valve
- D = Decrease travel of metering valve
- E = Quickens travel first 1" of movement
- F = Slows travel first 1" of movement

Figure 5-8 Adjustment of Oil Metering Valve

## BURNER AIR AND FUEL ADJUSTMENTS (continued)

### ITEM 9 ADJUSTMENT OF OIL SUPPLY PRESSURE REGULATOR VALVE

**DESCRIPTION** - Oil burners require a close regulation of the pressure at which oil is delivered to the nozzle. Small GPH burners normally use an oil pump which has a pressure regulator built-in, while larger capacity burners employ a separate pressure regulating valve.

**HOW IT WORKS** - Burner oil pumps are generally identified by the rate at which they can deliver (GPH), the pressure of the delivery (PSI) and the speed of rotation (RPM). The pump is usually capable of delivering more fuel than is required to meet firing requirements; therefore, the amount of oil delivered to the nozzle must be controlled. This control is accomplished thru use of an adjustable pressure regulating valve which reduces flow to the nozzle by causing more oil to be returned to the tank. Like most regulators, flow is controlled by an adjustable spring and each regulator has a pressure range over which it will reliably operate.

#### Oil Pressure Regulator

Pressure Adjustment Screw

Cover Screw and Gasket

Integral to Oil Pump

Separate

#### ADJUSTMENT PROCEDURE

**NOTE** See oil pressure regulator or oil pump manufacturer's instructions for detailed procedures.

1. Using screw driver, remove cover screw and gasket thereunder to gain access to the adjustment mechanism.
2. Use 1/8" Allen wrench to turn pressure adjusting screw clockwise to increase pressure and counter-clockwise to decrease.
3. For initial start-up: (set at 300 psi)

**NOTE** Pressure at which oil will be delivered to the nozzle cannot be determined until the burner is test fired. Be prepared to adjust the regulator as the burner is cycled through its firing sequence.

Figure 5-9 Adjustment of Oil Supply Pressure Regulator Valve

## BURNER AIR AND FUEL ADJUSTMENTS (continued)

### **ITEM 10** ADJUSTMENT OF LOW OIL PRESSURE SWITCH

**DESCRIPTION** - Low oil pressure switches are often times used to insure the oil pressure at the nozzle is adequate for proper atomization of the oil.

**HOW IT WORKS** - A pressure sensing device within the switch controls an electrical circuit normally interlocked with the flame safeguard causing the burner to recycle or shut down when the pressure sensed falls below the setting.

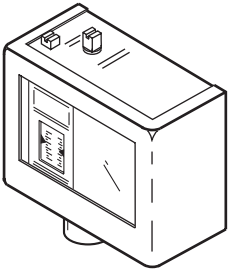
Low Oil Pressure Switch	ADJUSTMENT PROCEDURE
	<p data-bbox="834 594 1520 653"><b>NOTE</b> See pressure switch manufacturer's instructions for detailed procedure.</p> <ol data-bbox="899 695 1520 898" style="list-style-type: none"><li data-bbox="899 695 1520 758">1. From burner material list determine "Oil Pressure at Nozzle" (psig) requirement.</li><li data-bbox="899 800 1520 898">2. For initial start-up: Adjust to a pressure well below the "Oil Pressure at Nozzle" (psig) shown to allow the burner to be set up.</li></ol> <p data-bbox="834 940 1520 1037"><b>NOTE</b> Final adjustment must be done after the burner has been test fired. See burner start-up procedures.</p>

(Typical)

Figure 5-10 Adjustment of Low Oil Pressure Switch

## BURNER AIR AND FUEL ADJUSTMENTS (continued)

### ITEM 11 ADJUSTMENT OF CHARACTERIZED LINKAGE

**DESCRIPTION** - Characterized linkage provides the mechanical means to fine tune the fuel input (flow) to the burner in order to achieve maximum fuel efficiency and reduce harmful stack emissions.

**HOW IT WORKS** - There are nine (9) adjustment screws which control the contour of a flexible metal track upon which a roller and plunger mechanism travel. This mechanism in turn controls the linkage to the fuel valve, providing the precise amount of travel to dispense the right amount of fuel to the burner as it modulates to meet load demand. The objective is to shape the flexible metal track into what amounts to a “combustion efficiency profile”.

#### Characterized Linkage (typical)

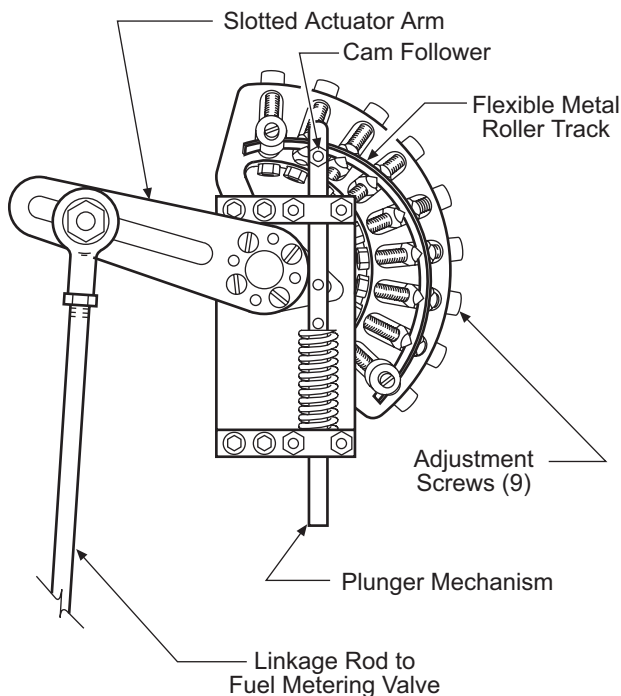

#### ADJUSTMENT PROCEDURE

Factory checkout verifies there is freedom of movement in all linkages throughout the 90° travel of the modulating motor. For gas systems, the butterfly (throttle) valve is set at the slightly open position. For oil systems, the oil metering valve is set at a predetermined position, depending on the specific valve used. Both settings are normally adequate to facilitate start-up.

Adjustment of the characterized linkage should only be done after the burner has been successfully started-up and taken from low-fire to high-fire several times. Any necessary adjustments to the fuel control linkages during start-up should be done at a ball joint connector or linkage rod coupling. The boiler, or other appliance being fired, should be warm.

Generally, combustion readings should be taken at each of the nine (9) adjustment screws in the quadrant. AS A STARTING POINT, low and high fire flue gas composition should be in the tabulated range shown below:

#### CAUTION

There should be no more than 3/16” variation between adjacent screws.

FUEL	LOW FIRE		HIGH FIRE	
	CO <sub>2</sub>	O <sub>2</sub>	CO <sub>2</sub>	O <sub>2</sub>
Natural Gas	7½ - 9	8½ - 5	9 - 10½	5 - 2½
#2 Oil	9 - 11	8½ - 5	11 - 12½	6 - 3½

The final fuel/air ratio curve must be determined on the basis of clean combustion at all firing rates. Sufficient combustion air must be available to keep the CO generated by a gas fire below 50 PPM at all rates. Smoke level on #2 oil should not exceed a #2 spot on the Bacharach scale.

Figure 5-11 Adjustment of Characterized Linkage

## BURNER AIR AND FUEL ADJUSTMENTS (continued)

### ITEM 12 ADJUSTMENT OF AIR FLOW SWITCH [DIAPHRAGM]

**DESCRIPTION** - The air flow switch is used to prove the flow of combustion air from the blower assembly. It causes the fuel valve to close or fail to open upon loss of or inadequate combustion air.

**HOW IT WORKS** - The air flow switch is wired in series with the flame safeguard. When the blower starts, creating an air flow through the burner housing, the switch closes delivering electricity to the flame safeguard.

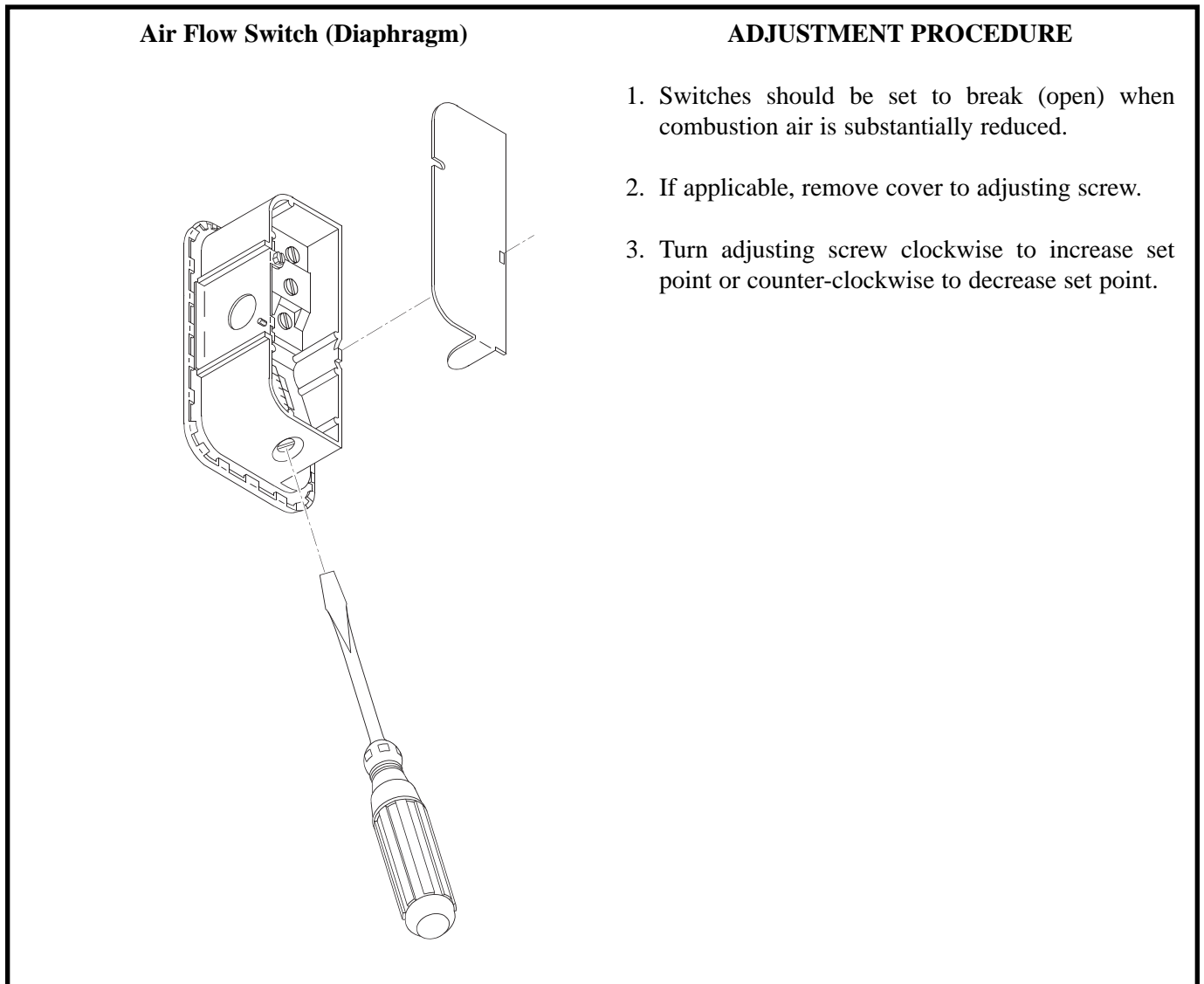

Figure 5-12 Adjustment of Air Flow Switch (Diaphragm)

### ITEM 13 ADJUSTMENT OF AIR FLOW SWITCH [SAIL]

**DESCRIPTION** - The air flow switch is used to prove the flow of combustion air from the blower assembly. It causes the fuel valve to close or fail to open upon loss of or inadequate combustion air.

**HOW IT WORKS** - The air flow switch is wired in series with the flame safeguard. When the blower starts, creating an air flow through the burner housing, the switch closes delivering electricity to the flame safeguard.

## BURNER AIR AND FUEL ADJUSTMENTS (continued)

### GP25A Air Flow Switches [with enclosures]

### ADJUSTMENT PROCEDURE

Loosen set screw and align sail and mercury switch as shown in the proper illustration, re-tighten set screw.

**NOTE** These switches are shown in the normally open position (no air flow).

**NOTE** Arrows indicate rotation of shaft to make switch contacts.

**NOTE** Hidden lines indicates position of sail with respect to mercury switch.

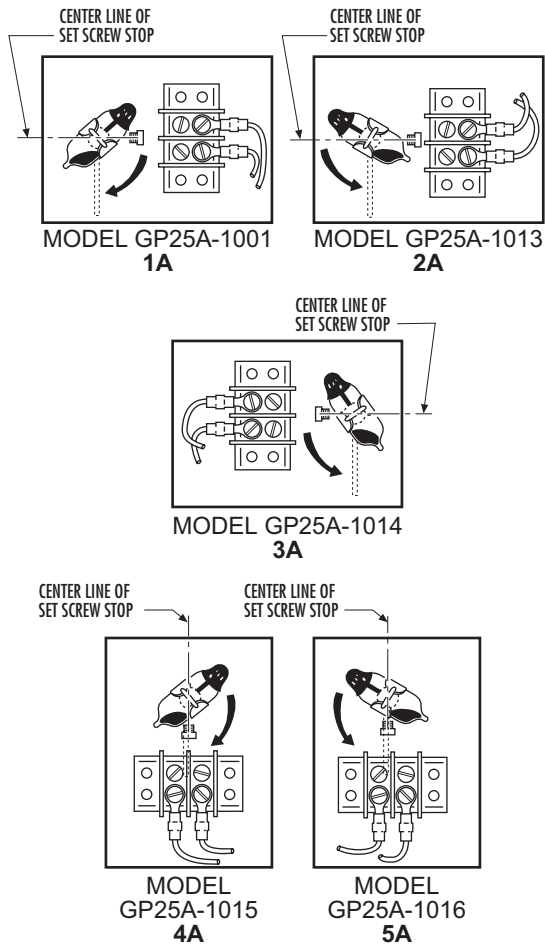

### SAIL ASSEMBLY



BURNER MODEL	MOTOR HP	AIR FLOW SWITCH ASSEMBLY NO.	SWITCH ILLUSTRATION	MAX. DEG. TRAVEL	MAKES AT DEG.	SAIL ASSEMBLY PART NO.
F10	All	GP25A-1001	1A	100	50	010425
F12	All	GP25A-1001	1A	100	50	010425
F14	All	GP25A-1001	1A	100	50	010425
F16	All	GP25A-1001	1A	100	50	010425
F18	All	GP25A-1001	1A	100	50	010425
FG	All	GP25A-1013	2A	100	50	010425
FGD	All	GP25A-1016	5A	100	50	010425
FL10	All	GP25A-1014	3A	100	50	010425
FL12	All	GP25A-1014 (Above Blower)	3A	100	50	010425
FL12	All	GP25A-1015 (Below Blower)	4A	100	50	010425
FL14	All	GP25A-1015	4A	100	50	010425
FL16	All	GP25A-1015	4A	100	50	010425
FL18	All	GP25A-1015	4A	100	50	010425
FR	All	GP25A-1001	1A	100	50	010425
FRL	All	GP25A-1015	4A	100	50	010425

Figure 5-13 Adjustment of Air Flow Switch (Sail)

# PART VI

## BURNER START-UP

### CAUTION

This bulletin has been prepared as a guide in burner start-up operations. It is written for the start-up specialist who is thoroughly qualified both by training and experience.

Due to wide variations in engineering specifications, state and local codes, utility and insurance underwriters requirements, etc., the contents herein are of a general nature. If additional information is required or if questions arise concerning specific requirements, please contact your local representative or the factory.

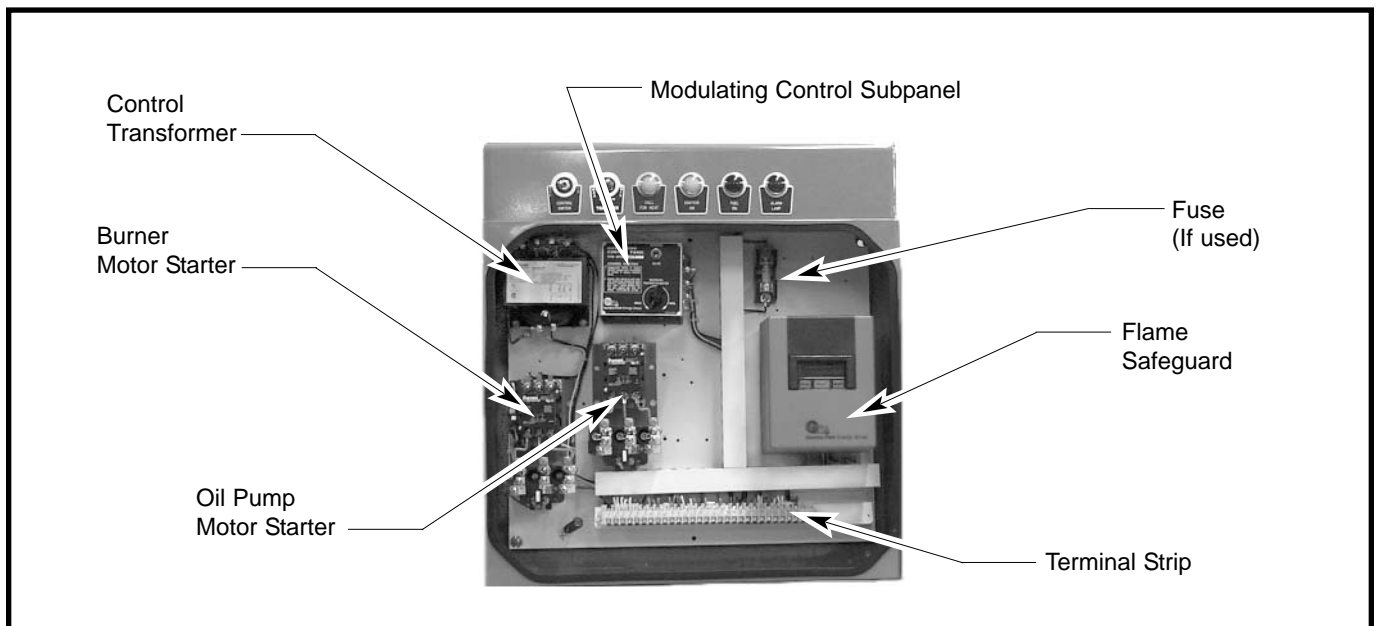

Typical Control Panel

#### 1. FLAME SAFEGUARD INSTALLATION -

Assure flame safeguard is properly installed in its subbase.

#### 2. IDENTIFICATION OF CONTROLS -

Review the burner operating sequence and wiring diagram in the instructions manual. Study these items and identify the various controls from the typical control panel assembly shown above.

#### NOTE

The burner flame safeguard is often times packaged and shipped in a separate carton; however, the control cabinet will contain the mounting subbase which is installed and prewired at the factory. See separate instructions on flame safeguard for mounting the unit in the subbase.

#### NOTE

Do not proceed with start-up unless all applicable checklist  items in Part I and preliminary adjustment requirements in Part V have been satisfied.

If the burner is a combination gas-oil unit, it is recommended that the burner be fired on gas first so the correct input rate in BTU's per hour may be determined by reading the gas meter.

## BURNER START-UP (continued)

### WARNING!

Be certain combustion chamber, flues and surrounding areas are free of gas accumulations, oil or oil vapor and other combustibles such as paint thinners, cleaning solutions, etc. An explosimeter (Mine Safety Appliances Co., Model No. 2A, or equivalent) should be used to make this determination.

### 3. GAS BURNERS - (See Paragraph 4 for Oil Burners)

#### 3.1 REVIEW BURNER MATERIAL LIST IN THE INSTRUCTIONS MANUAL AND ANNOTATE THE FOLLOWING INFORMATION:

- (1) Firing Rate (MBH)
- (2) Cubic Feet of Gas per Hour (CFH)
- (3) BTU per Cubic Foot (BTU/CF)
- (4) Required Gas Pressure at Control Inlet (inches w.c.)
- (5) Required Gas Pressure at Orifices (taken at burner manifold) (inches w.c.)

### NOTE

The above information is pertinent to setting up the burner.

#### 3.2 START-UP SETTINGS OF BURNER CONTROLS - Using the burner operating sequence, proceed up to the step where the manual pilot gas cock is to be opened.

### WARNING!

During initial start-up, the operator must be on constant alert for emergency conditions such as fuel leaks, electrical malfunctions, etc. The location of all manual shutoff valves and disconnect switches should be clearly in mind so the burner can be quickly shut down if necessary. Should the burner fail to ignite, never manually manipulate the flame safeguard sequence which provides for purging of the combustion chamber.

#### 3.3 Using the Manufacturer's Instructions Bulletin on the flame safeguard, proceed with checkout to insure proper function of the safeguard under burner operational conditions. Table 6-1 shows those checks that should be performed.

<b>The Items Below Summarize the Flame Safeguard Checkout Tests Required for Each Type of Installation</b>	
Checkout Items	When Performed
1. Preliminary Inspection	For all Installations
2. Flame Signal Measurement	For all Installations
3. Initial Lightoff Check with Proven Pilot	If Pilot must be proven before the Main Fuel Valve can open
4. Pilot Turndown Test	If Pilot must be proven before the Main Fuel Valve can open
5. Hot Refractory Hold-In Test	For all Photocell (rectifying or infrared lead sulfide) Applications
6. Hot Refractory Override Test	For all Infrared (lead sulfide photocell) Detector Applications
7. Ignition Spark Response Test	For all Ultraviolet Detector Applications
8. Flame Signal with Hot Combustion Chamber	For all Installations
9. Safety Switch Lockout Tests	For all Installations

**Table 6-1 Flame Safeguard Checkout Summary**

## BURNER START-UP (continued)

### NOTE

While performing these checks, certain adjustments and readings must be made at the appropriate time. These include, but are not limited to:

- (1) Burner Combustion Air
- (2) Gas Pressure (at control inlet and orifice)
- (3) Boiler Limit Controls
- (4) Draft Controls
- (5) Other Controls Electrically Interlocked with the Burner Control System.
- (6) Gas Flow thru Utility Meter (CFH)
- (7) CO<sub>2</sub> and CO
- (8) Stack Temperature

### 3.4 LOW AND HIGH GAS PRESSURE SWITCHES

- If burner is equipped with low and high gas pressure switches, perform the following steps:

#### LOW GAS PRESSURE SWITCH ADJUSTMENT

- 3.4.1 Close the main manual gas shutoff valve and install a manometer or gas gauge in the upstream test port of the safety gas shutoff valve.
- 3.4.2 Reopen the main manual gas shutoff valve.
- 3.4.3 Cycle the burner to high fire and take gas pressure reading on manometer. Using the main manual gas shutoff valve, throttle down the gas flow to a point where the burner just starts to become unstable, makes noise or the CO level goes above 400ppm but in no case should the gas pressure go below 50% of the initial pressure reading. Increase gas pressure by opening main manual gas valve until gas pressure increases midway between last reading and the initial reading. Adjust the low gas pressure switch downward until it breaks and shuts down the burner. Restore main manual gas shutoff valve to full open.
- 3.4.4 To insure the switch is functionally sound and properly installed, recycle the burner to high fire and again use the main manual gas shutoff valve to throttle the gas flow. The low gas pressure switch should immediately break and shut down the burner at the reduced pressure setting.

3.4.5 Turn main manual gas shutoff valve to off, then remove manometer and reinstall test plug in gas safety shutoff valve. Restore main manual gas shutoff valve to full open.

3.4.6 Cycle the burner on-off several times to assure the switch will not cause nuisance shutdowns as the burner ignites.

#### HIGH GAS PRESSURE SWITCH ADJUSTMENT

3.4.7 Cycle the burner to high fire. Slowly adjust the switch downward until the switch breaks and shuts down the burner, then reverse the adjustment so the setting is approximately 10-20% greater than the reading at which the switch broke.

#### EXAMPLE:

If the switch broke and shut down the burner at 4.0" w.c., then set the switch at 4.5" w.c.

3.4.8 Cycle the burner on-off several times to assure the switch will not cause nuisance shutdowns as the burner ignites.

3.5 FINAL CO<sub>2</sub> AND CO ANALYSIS - With gas input rate established, perform a final CO<sub>2</sub> analysis and make air adjustments as necessary. The final air settings should produce a flue gas analysis of between 5-1/2% and 4% O<sub>2</sub> (8-1/2% and 9-1/2% CO<sub>2</sub>) with minimal CO.

### CAUTION

Do not set fire visually on forced draft burners. Instruments are the only safe and reliable means to determine the proper adjustments.

### 3.6 MOTOR RUNNING CURRENT AND VOLTAGE CHECK

3.6.1 Measure motor running current after final air adjustments have been made. Current should not exceed motor service factor amps shown on motor nameplate.

3.6.2 Check control voltage on terminals 1 and 2 as motor starts. Voltage should not drop below 102 volts (even momentarily) or difficulty may occur in control operation. Extreme voltage drop indicates inadequate service wire size to the burner.

# BURNER START-UP (continued)

## 3.7 BURNER SAFETY CHECK

**GAS FIRING NOTES** \_\_\_\_\_  
\_\_\_\_\_  
\_\_\_\_\_  
\_\_\_\_\_  
\_\_\_\_\_  
\_\_\_\_\_  
\_\_\_\_\_  
\_\_\_\_\_  
\_\_\_\_\_  
\_\_\_\_\_  
\_\_\_\_\_  
\_\_\_\_\_

3.7.1 Start and stop the burner several times to insure proper operation. Check for proper functioning of low-water cutoff, high limit and/or operating control.

3.7.2 Check operation of flame safeguard by simulating a flame failure, making certain the burner locks out on safety within the time limits of the control. Use Table 6-1 for flame safeguard check out.

3.7.3 Using burner operating sequence, start the burner in accordance with the step by step operating sequence procedure. As the burner enters the flame safeguard sequence, verify each burner function at the timing indicated.

3.8 NORMAL OPERATION - Providing the setup and checkout operations outlined in Items 3 thru 3.7 above have been properly completed and all tests have been found to be satisfactory, the burner is now ready for normal gas firing operations

## 4. PRESSURE ATOMIZING OIL BURNER - (See 1-F-40.31 for Air Atomizing Oil Burners)

4.1 REVIEW BURNER MATERIAL LIST IN THE INSTRUCTIONS MANUAL AND ANNOTATE THE FOLLOWING INFORMATION:

- (1) Oil Firing Rate (GPH)
- (2) Oil Pressure at Nozzle (PSIG)

**NOTE**

The above information is pertinent to setting up the burner.

4.2 ADJUSTMENTS DURING START-UP - Using the burner operating sequence, proceed up to the step where the manual pilot gas cock is to be opened.

**WARNING!**

During initial start-up, the operator must be on constant alert for emergency conditions such as fuel leaks, electrical malfunctions, etc. The location of all manual shutoff valves and disconnect switches should be clearly in mind so the burner can be quickly shut down if necessary. Should the burner fail to ignite, never manually manipulate the flame safeguard sequence which provides for purging of the combustion chamber.

4.3 Using the manufacturer's instructions bulletin on the flame safeguard, proceed with those tests which verify pilot and flame signal characteristics.

## BURNER START-UP (continued)

The Items Below Summarize the Flame Safeguard Checkout Tests Required for Each Type of Installation	
Checkout Items	When Performed
1. Preliminary Inspection	For all Installations
2. Flame Signal Measurement	For all Installations
3. Initial Lightoff Check with Proven Pilot	If Pilot must be proven before the Main Fuel Valve can open
4. Pilot Turndown Test	If Pilot must be proven before the Main Fuel Valve can open
5. Hot Refractory Hold-In Test	For all Photocell (rectifying or infrared lead sulfide) Applications
6. Hot Refractory Override Test	For all Infrared (lead sulfide photocell) Detector Applications
7. Ignition Spark Response Test	For all Ultraviolet Detector Applications
8. Flame Signal with Hot Combustion Chamber	For all Installations
9. Safety Switch Lockout Tests	For all Installations

**Table 6-2 Flame Safeguard Checkout Summary**

- 4.4 After pilot characteristics and flame signal have been proven satisfactory, permit the flame safeguard to cycle through to main burner ignition.
- 4.5 Make low fire input, fuel-air ratio and combustion adjustments. Observe oil spray through sight glasses and determine if spray is impinging on swirler cylinder. If so, loosen backplate collar set screws and slide the drawer assembly forward until impingement ceases; then re-tighten set screws.
- 4.6 After proper boiler warm-up, run burner to high fire and make input and fuel-air ratio adjustments. Observe base of flame through back-plate sight glasses.
- 4.7 Oil drawer assembly adjustments for high fire.

**NOTE**

Changing the oil nozzle/air diffuser relationship involves different procedures depending on the oil drawer assembly used. (See Figure 5-7)

**NOTE**

Drawer assemblies WITHOUT the quick draw oil gun feature requires removal of the complete oil drawer from the burner housing, then re-positioning the air diffuser. For those WITH the quick draw feature, the relationship can be changed by loosening the set screws that secure the oil gun within the guide tube, then sliding the gun back or forward while the drawer is installed in the burner.

Set screws or clamp screws must be re-tightened after each adjustment.

- 4.7.1 If air diffuser shows signs of carboning or if diffuser slots appear dark, move oil nozzle forward by small increments. If flame exhibits signs of instability, move nozzle to the rear a little at a time, until stability is obtained.

## BURNER START-UP (continued)

4.7.2 Manually run the burner to low fire and visually determine if there is any oil spray impingement on diffuser center hole. If so, re-check nozzle pressure and primary air adjustments and re-adjust as required.

4.7.3 If impingement persists, move oil nozzle forward until impingement ceases.

4.7.4 After oil drawer adjustments have been made, run burner through several ignitions, low fire an high fire cycles to check for proper performance.

4.8 Removal of oil gun for extended gas firing.

### WARNING!

If this operation is going to be done while the burner is firing on gas, the burner must be manually run to its low-est firing rate and held there until com-pleted.

4.8.1 Make sure set screws in rear collar are holding oil gun securely.

4.8.2 Disconnect fittings on oil inlet and return lines.

4.8.3 Using a large flat bladed screw driver, rotate the three “quarter turn” fasteners on the oil gun flange 90° CCW to disengage them.

4.8.4 Pull oil gun straight out of guide tube.

### WARNING!

Do not tamper with the position of the collar after the oil gun is removed. Coverplate must be installed if burner is to be fired on gas with oil gun removed.

4.8.5 Install cover plate on guide tube flange with the three captive “quarter turn” studs. (See Figure 5-7)

4.9 Re-installation of the oil gun. To re-install the oil gun, reverse the order of the steps outlined above.

If the position of the collar has not been changed, the oil nozzle will return to its original relation-ship with the air diffuser when the three flange studs are re-engaged.

## 4.10 FINAL CO<sub>2</sub> AND SMOKE ANALYSIS

### CAUTION

Do not set fire visually on forced draft burners. Instruments are the only safe and reliable means to determine the proper adjustment.

### 4.10.1 IF COMBINATION GAS-OIL BURNER

- Leave combustion air adjustments set as they were for gs firing and adjust the high fire supply oil pressure to obtain a flue gas analysis as shown in table below.

### NOTE

Above method of setting up combina-tion burners assures a smooth transfer between fuels without further adjust-ments and allows for simplified capac-ity calculations.

4.10.2 HIGH FIRE SETTING - Using the manu-al potentiometer, bring the burner up to the high fire position.

4.10.3 Adjust the nozzle oil pressure to the PSIG shown on the burner material list. (See Figures 5-8 and 5-9)

The high fire oil nozzle pressure is set by adjusting the oil pressure regulating valve while the oil metering valve may be used for trim purposes.

If possible, use 90° rotation of the oil metering valve between low and high fire.

Adjust air inlet louver for proper CO<sub>2</sub> and smoke readings at full firing rate. (See Figure 5-2)

Type Oil	% CO <sub>2</sub>	% O <sub>2</sub>	Smoke No.
#2	11 - 12½	3.5 - 6	0 - 2

# BURNER START-UP (continued)

- 4.10.4 After obtaining the proper combustion on high fire, drive the burner back to low fire.
- 4.10.5 If necessary, reset low fire for proper combustion and check burner at 25%, 50% and 75% for rich or lean spots in the firing rate. The linkage arms may have to be changed to get more or less combustion air or oil on high fire.
- 4.11 **LOW OIL PRESSURE SWITCH** - If burner is equipped with a low oil pressure switch, the switch should be set 10 to 15% below the final adjusted high fire “supply” oil pressure. Perform the following steps:
  - 4.11.1 Annotate the “supply” oil pressure (PSIG) while the burner is at high fire.
  - 4.11.2 Adjust the switch 10 to 15% below this pressure.
  - 4.11.3 With the burner at low fire, slowly adjust the oil pressure regulator to obtain a reduced “supply” pressure making sure the switch cuts off the burner flame as the oil pressure drops past the PSI setting.
  - 4.11.4 Adjust the oil pressure regulator to a higher pressure to allow the burner to be recycled to high fire. then restore the high fire “supply” oil pressure annotated in step 4.11.1 above.
- 4.12 **CLEANING OF OIL SYSTEM COMPONENTS AFTER START-UP**

**NOTE**

It is not uncommon for the oil system components to become dirty or clogged during initial start-up as foreign matter from the oil lines is pumped through the system.

**WARNING!**

Turn OFF the main manual fuel shutoff valves including pilot gas cock, if applicable.

Turn OFF all electrical disconnects to the burner and any other equipment or systems electrically interlocked with the burner.

- 4.12.1 Remove oil gun and/or oil drawer assembly, disassemble oil nozzle and clean using solvent and wooden toothpick to avoid damage to the finely machined surfaces.
- 4.12.2 Reassemble oil nozzle and replace oil drawer assembly.
- 4.12.3 Restore valves and electrical disconnects to ON.
- 4.13 **BURNER SAFETY CHECK**
  - 4.13.1 Start and stop the burner several times to insure proper operation. Check for proper functioning of low-water cutoff, high limit and/or operating control.
  - 4.13.2 Check operation of flame safeguard by simulating a flame failure, making certain the burner locks out on safety within the time limits of the control. Use Table 6-2 for final flame safeguard check out.
  - 4.13.3 Using burner operating sequence, start the burner in accordance with the step by step operating sequence procedure. As the burner enters the flame safeguard sequence, verify each burner function at the timing indicated.
- 4.14 **NORMAL OPERATION** - Providing the set-up and checkout operations outlined above have been properly completed and all tests have been found to be satisfactory, the burner is now ready for normal oil firing operations.

**OIL FIRING NOTES** \_\_\_\_\_

\_\_\_\_\_

\_\_\_\_\_

\_\_\_\_\_

\_\_\_\_\_

\_\_\_\_\_

\_\_\_\_\_

# PART VII

## TROUBLE SHOOTING

The following is a list of possible problems and conditions that may exist on startup and the corrective measures to be taken. This deals only with combustion problems. Please refer to your flame safeguard manual and/or the John Zink Company, L.L.C. wiring diagram for any electrical problems.

1. Oil burner does not light, goes out on flame failure in main flame position:
  - a. Main oil valve not energized.
  - b. Oil metering valve not open far enough.
  - c. Oil strainer plugged.
  - d. Air louver open too far.
2. Oil burner lights but flame does not retain to burner head:
  - a. Drawer assembly not positioned properly. Move forward or backward.
  - b. Oil supply pressure at nozzle too low.
  - c. By-pass pressure at nozzle too low.
  - d. Air louver too far open.

### NOTE

If the oil fire is not retaining to the combustion head, the burner will build carbon on the head and fireside surfaces of the boiler. This can best be seen through the rear peep sight on the burner. Look for rivulets of oil running down the vanes of the air diffuser and/or a wetting of oil on the inner fire cylinder of the swirler. Looking at the flame from the rear or the burner, the color of the flame should be the same all across the head. A darker color at the center usually means it is blowing off the head.

Look at the flame from the rear of the boiler. If it is retaining to the head, it will have a definite shape. If it is blowing off the head, the center of the fire will appear dark and it will be scattered over the boiler with no apparent shape or pattern. There will also be pulsation of the burner flame.

3. Burner flame retains to head on lo-fire but blows off while modulating to hi-fire and/or blows out resulting in a flame failure: (Also See Item 2a - 2b above)
  - a. Louver box may be opening too fast, causing a lean spot at about 25% or 50% of range. If so, reduce the travel of the air louver by moving the ball swivel in on the jack shaft.
    - (1) To slow down the louver opening in the first 1.0" of travel: Normally, the linkage arm on the jack shaft and the louver box are positioned approximately 45° down from center. Loosen the two set screws in the linkage arm at the louver box operated from the common jack shaft; swing the arm up until it is about 10° off center (or almost straight out from the burner) then tighten set screws and linkage rod. The louver will open much slower in the first 1.0" of travel, but open the same for hi-fire.
    - (2) To speed up the louver travel in the first 1.0" of travel: Do the same as above except in this case, increase the angle or move the arm down on the shaft at the louver box until it is 70° or so down from center. This will cause the louver to "pop" open at the start but still open to the same amount for hi-fire.

### NOTE

The only sure way to check for the above mentioned lean spot is with proper CO<sub>2</sub> test equipment. CO<sub>2</sub> reading should increase from approximately 10% CO<sub>2</sub> on lo-fire to 12 - 13% on hi-fire without any dips down to 7 - 8% CO<sub>2</sub>.

- (3) If it is determined the air louver is set properly, the same linkage arm adjustments can be made on the oil metering valve to open it faster or slower, just off lo-fire.
- b. Check oil strainers for possible blockage. On lo-fire, there may not be enough oil flow. As unit modulates to hi-fire, the burner is starved for oil.



## PERIODIC TESTING RECOMMENDED CHECK LIST

ITEM	FREQUENCY	ACCOMPLISHED	REMARKS
Check burner and boiler control linkage	Daily	Operator	Make visual inspection
Check fuel system for leaks	Daily	Operator	Make inspection visually and with leak detection instrumentation
Gauges, monitors and indicators	Daily	Operator	Make visual inspection and record readings in log
Oil pump inlet vacuum	Daily	Operator	Make visual inspection and record readings in log
Oil pressure at pump, burner, and/or regulating valve	Daily	Operator	Make visual inspection and record readings in log
Instrument and equipment settings	Daily	Operator	Make visual check against recommended specifications
Check burner flame	Daily	Operator	Visual inspection for changes
Firing rate control	Weekly Semiannually Annually	Operator Service technician Service technician	Verify factory settings Verify factory settings Check with combustion test
Stack temperature	Daily	Operator	Record in log
Flue, vent, stack or outlet dampers	Monthly	Operator	Make visual inspection of linkage, check for proper operation
Ignitor	Weekly	Operator	Make visual inspection, check flame signal strength if meter fitted (see "Combustion safety controls")
Oil nozzle(s) and Strainers	Semiannually	Operator	Check for dirt and wear
Fuel Valves			
Pilot and main	Weekly	Operator	Open limit switch - make aural and visual check - check valve position indicators and check fuel meters if so fitted
Pilot and main gas or main oil	Annually	Service technician	Perform leakage tests - refer to instructions
Combustion safety controls			
Flame failure	Weekly	Operator	Close manual fuel supply for (1) pilot, (2) main fuel cock, and/or valve(s); check safety shutdown timing; log
Flame signal strength	Weekly	Operator	If flame signal meter installed, read and log; for both pilot and main flames, notify service organization if readings are very high, very low, or fluctuating; refer to instructions
Pilot turndown tests	As required/annually	Service technician	Required after any adjustments to flame scanner mount or pilot burner. Verify annually - refer to instructions
Refractory hold in	As required/annually	Service technician	See "Pilot turndown tests"

## PERIODIC TESTING RECOMMENDED CHECK LIST

ITEM	FREQUENCY	ACCOMPLISHED	REMARKS
Low-water fuel cutoff and alarm	Daily/Weekly Semiannually	Operator Operator	Refer to instructions Perform a slow drain test in accordance with ASME Boiler and Pressure Vessel Code Section VI
High limit safety control	Annually	Service Technician	Refer to instructions
Operating control	Annually	Service technician	Refer to instructions
Low draft, fan, air pressure, and damper position interlocks	Monthly	Operator	Refer to instructions
Atomizing air/steam interlocks	Annually	Service technician	Refer to instructions
High and low gas pressure interlocks	Monthly	Operator	Refer to instructions
High and low oil pressure interlocks	Monthly	Operator	Refer to instructions
High and low oil temperature interlocks	Monthly	Operator	Refer to instructions
Fuel valve interlock switch	Annually	Service technician	Refer to instructions
Purge switch	Annually	Service technician	Refer to instructions
Burner position interlock	Annually	Service technician	Refer to instructions
Low fire start interlock	Annually	Service technician	Refer to instructions
Automatic changeover control (dual fuel)	At least annually	Service technician	Under supervision of gas utility
Safety valves	As required	Operator	In accordance with procedure in Section VI, ASME Boiler and Pressure Vessel Code, Recommended Rules for Care and Operation of Heating Boilers
Inspect burner components	Semiannually	Service technician	Refer to instructions
Clean burner fan	Annually or as required	Operator	Remove buildup on fan blades

**NOTES:**

## NOTES:

# PART VIII

## SUPPLEMENTARY DATA

This manual should be kept with other literature on your boiler room equipment as a complete reference source for maintenance and service.

