



CB780E/784E

Burner Control with Valve Proving

Operation Manual



Manual Part No. 750-234

10/2008

CB780E/CB784E Relay Modules with Valve Proving Installation and Operating Instructions

PRODUCT DATA



APPLICATION

The Cleaver-Brooks CB780E/CB784E is a microprocessor based integrated burner control for automatically fired gas, oil, or combination fuel single burner applications. The CB780E consists of a Relay Module and Keyboard Display Module. The CB784E consists of the Relay Module only. A subbase, Amplifier, and Purge Card are required to complete the system. Options include Personal Computer Interface, DATA CONTROLBUS MODULE™, Remote Display Mounting, First-Out Expanded Annunciator and COMBUSTION SYSTEM MANAGER™ Software.

The CB780E/CB784E is programmed to provide a level of safety, functional capability, and features beyond the capacity of conventional controls.

Functions provided by the CB780E/CB784E include automatic burner sequencing, flame supervision, system status indication, system or self-diagnostics, and troubleshooting.

The CB780E/CB784E offer the Valve Proving test feature.

Using the 833-2727 Keyboard Display (standard on the CB780E), the following features can be set-up:

- **Post Purge time—Up to 60 minutes—Device shipped with 15 seconds Post purge**
- **Valve Proving features include:**
 - VPS test time
 - When (Never, Before, After, Split or Both)

See the 833-2727 Instructions (750-248) for its features. Series 5 can be programmed for ModBus communication.

At commissioning time, the Valve Proving System may be scheduled to occur at one of five different times:

- **Never—Device default as received—Valve proving does not occur.**
- **Before—Valve proving before run concurrent with Pre-Purge.**
- **After—Valve proving occurs after the Run state, before the device goes to Standby (Concurrent with Post-Purge, if selected.)**
- **Both—Valve proving occurs at both times Before and After, noted above.**
- **Split—The main valve 2 (MV2) (high pressure) seat test is performed at the Before time and the main valve 1 (MV1) (low pressure) seat test is performed during the After time.**

Contents

Application	1
Features	2
Specifications	2
Principal Technical Features	6
Installation	8
Assembly	15
Static Checkout	23
Operation	25
Troubleshooting	38



The following assumptions apply when using the CB780E/CB784E:

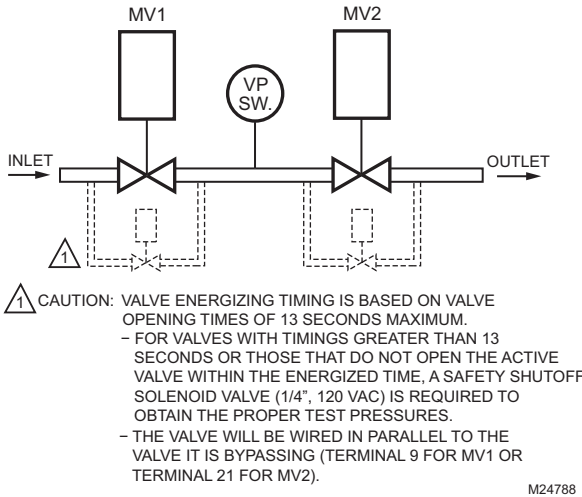

Fig. 1. The valve proving system.

MV1—Wired to terminal 9. It is located in the most upstream position of the main gas valve train.

VPS—Valve Proving Switch: Setpoint at 1/2 of Main Valve inlet pressure.

MV2—Wired to terminal 21. It is the main valve located closest to the burner.

The PII—Pre-Ignition Interlock (or Proof of Closure Switch) for terminal 20 can be installed on MV1, MV2, or as a series connection through both valves.

FEATURES

- **Safety features:**
 - Safety interlock.
 - Closed loop logic test.
 - Dynamic AMPLI-CHECK™.
 - Dynamic input check.
 - Dynamic safety relay test.
 - Dynamic self-check logic.
 - Expanded safe-start check.
 - High Fire Purge Switch test.
 - Internal hardware status monitoring.
 - Low Fire Start Switch test.
 - Tamper-resistant timing and logic.
- Access for external electrical voltage checks.
- Application flexibility.
- Communication interface capability.
- Dependable, long-term operation provided by microcomputer technology.

- First-out annunciation and system diagnostics provided by a 2-row by 20-column Vacuum Fluorescent Display (VFD) located on the Keyboard Display Module.
- First-out expanded annunciation with 26 Light Emitting Diodes (LEDs) for limits and interlocks (optional).
- Five function Run/Test Switch.
- Interchangeable plug-in flame amplifiers.
- Local or remote annunciation of operation and fault information.
- Nonvolatile memory for retaining history files and sequencing status after loss of power.
- Remote reset (optional).
- Report generation (optional).
- Five sequence information LEDs
- Burner controller data:
 - Sequence status.
 - Sequence time.
 - Hold status.
 - Lockout/alarm status.
 - Flame signal strength.
 - Expanded annunciation status.
 - Total cycles of operation.
 - Total hours of operation.
 - Fault history of six most recent faults:
 - Cycles of operation at time of fault.
 - Expanded annunciator data at time of fault.
 - Fault message and code.
 - Hours of operation at time of fault.
 - Sequence status at time of fault.
 - Sequence time at time of fault.
 - Diagnostic information:
 - Device type.
 - Flame amplifier type.
 - Flame failure response time.
 - Manufacturing code.
 - On/Off status of all digital inputs and outputs.
 - Selected prepurge time.
 - Software revision and version of CB780E/CB784E and Keyboard Display Module.
 - Status of configuration jumpers.
 - Status of Run/Test Switch.

SPECIFICATIONS

Electrical Ratings (see Table 1):

Voltage and Frequency: 120 Vac (+10/-15%), 50 or 60 Hz (±10%).

Keyboard Display Module: 13 Vdc peak full wave rectified (+20/-15%).

Power Dissipation:

CB780E/CB784E: 10W maximum.

Display Module: 3W maximum.

Maximum Total Connected Load: 2000 VA.

Fusing: 15A maximum, Type SC or equivalent—fast blow.

Table 1. Terminal Ratings.

Terminal No.	Description	Ratings (120 Vac)
G	Flame Sensor Ground ^a	—
Earth G	Earth Ground	—
L2(N)	Line Voltage Common	—
3	Alarm	1A pilot duty
4	Line Voltage Supply (L1) ^b	120 Vac (+10%/-15%), 50 or 60 Hz (±10%).
5	Burner Motor	9.8AFL, 58.ALR (inrush)
6	Burner Controller and Limits Demand (Not Valve Proving)	1 mA.
7	Lockout/Running Interlock	8A run, 43A inrush
8	Pilot Valve/Ignition	c
9	Main Fuel Valve	c
10	Ignition	c
F(11)	Flame Sensor	60 to 220 Vac, current limited
12	Firing Rate High Fire	75VA pilot duty
13	Firing Rate Common	75VA pilot duty
14	Firing Rate Low Fire	75VA pilot duty
15	Firing Rate Modulate	75VA pilot duty
16	Valve Proving Switch	1 mA
17	Demand—Valve Proving	1 mA
18	Low Fire Switch Input	1 mA
19	High Fire Switch Input (7800/40L only)	1 mA
20	Pre-Ignition Interlock Input	1 mA
21	Interrupted First Stage Oil Valve or MV2	c
22	Shutter	0.5A

^a The relay module must have a good earth ground providing a connection between the subbase and the control panel or the equipment. The earth ground wire must be capable of conducting the current to blow the 15A fuse (or breaker) in event of an internal short circuit. The relay module requires a low impedance ground connection to the equipment frame, which, in turn, requires a low impedance connection to earth ground.

^b 2000 VA maximum connected load to relay module assembly.

^c See Table 2 and 3.

Table 2. Combinations for Terminals 8, 9, 10, and 21.

Combination No.	Pilot Fuel #	Main 9	Ignition 10	Valve 21
1	C	F	No load	No load
2	B	F	No load	No load
3	No load	F	No load	B
4	F	F	A	No load
5	No load	F	A	F
6	D	F	A	No load
7	No load	D	A	D
8	D	D	A	No load
9	No load	D	A	D

Table 3. Explanation of Each Combination

A	B	C	D	E
4.5A ignition	50 VA Pilot Duty ^a plus 4.5A ignition.	180 VA ignition plus motor valve with: 660 VA inrush, 360 VA, open, 260 VA hold.	2A Pilot Duty. ^a	64 VA Pilot Duty. ^a plus motor valves with: 3850 VA inrush, 700 VA open, 250 VA hold.

Table 4. Valve Proving Combinations.

	Pilot Valve	Main Valve 1	Ignition	Main Valve 2
Combination	Terminal 8	Terminal 9	Terminal 10	Terminal 21
10 ^a	--	D	A	D
11	--	D	A	F
12	--	F	A	D
13	--	F	A	F
14 ^b	C	D	--	D
15	C	D	--	F
16	C	F	--	D
17	C	F	--	F
18	B	D	--	D
19	B	D	--	F
20	B	F	--	D
21	B	F	--	F
22	D	D	A	D
23	D	D	A	F
24	D	F	A	D
25	D	F	A	F

^a JR2 intact - Direct Spark

^b ED - Pilot System

Environmental Ratings:

Ambient Temperature:

Operating: -40°F to +140°F (-40°C to +40°C).

Storage: -40°F to +150°F (-40°C to +66°C).

Humidity: 85% RH continuous, noncondensing.

Vibration: 0.5G environment.

Dimensions:

Refer to Fig. 2 and 3.

Weight:

CB780E/CB784E: 1 pound 10 ounces, unpacked.

Keyboard Display Module: 4 ounces, unpacked.

IMPORTANT:

Flame Detection System available for use with CB780E/CB784E. To select your Plug-in Flame Signal Amplifier and matching Flame Detector, see Table 5.

Table 5. Flame Detection Systems (Fig. 4, 5, 6)

Plug-In Flame Amplifiers				Applicable Flame Detectors			
Type	Color	Self-Checking	Part Number	Flame Failure Response Time	Fuel	Type	Part Number
Infrared	Red/White	No	833-3495	3 sec.	Gas, oil, coal	Infrared (Lead Sulfide)	817-4133
		Dynamic AMPLI-CHECK™	833-3496 ^a				
Ultraviolet	Purple	No	833-2724		Gas, oil	Ultraviolet	817-1743 ^b
Ultraviolet Self-Check	Green	Dynamic Self-Check	833-2741 ^c		Gas, oil, coal	Ultraviolet (Purple Peeper®)	817-1121

^a Circuitry tests the flame signal amplifier 12 times a minute during burner operation and shuts down the burner if the amplifier fails.

^b The 817-1743 Flame detector should be used only on burners that cycle on-off at least once every twenty-four hours. Appliances with burners that remain on for twenty-four hours continuously or longer should use the 817-1121 Flame Detector with 833-2741 Amplifier as the ultraviolet flame detection system.

^c Circuitry tests all electronic components in the flame detection system (amplifier and detector) 12 times a minute during burner operation and shuts down the burner if the detection system fails. Series 4 amplifiers check 60 to 120 times per minute.

Approvals:

Underwriters Laboratory, Inc., listed, File No. MP268,

Guide No. MCCZ.

Canadian Standards Association certified, LR9S329-3.

FM/IRI acceptable.

Federal Communications Commission, Part 15,

Class B—Emissions

Required Components:

CB780E: 120 Vac, 50/60 Hz, 833-03517.

CB784E: 120 Vac, 50/60 Hz, 833-03518.

Wiring Subbase 833-2725

Plug-in Flame Signal Amplifier: see Table 5.

Plug-in Purge Timer Cards: selectable:

833-2730—30 sec.

833-2731—60 sec.

833-2732—90 sec.

833-2733—2 1/2 min.

NOTE: The CB780E and CB784E are identical, except for the Keyboard Display Module, which is standard with the CB780E and optional with the CB784E.

Accessories:

Optional:

DATA CONTROLBUS MODULE—part no. 833-2729. Provides communication and remote reset capabilities on CB780E; remote display capabilities on CB780E and CB784E.

CB783 Expanded Annunciator—part no. 833-2726.
 Keyboard Display Module—part no. 833-2727.
 Remote Mounting Kit for the Keyboard Display, NEMA 4—
 part no. 833-2740.

Tester—part no. 626-5050.
 833-2760 5-Wire Connector for the Keyboard Display Module.
 Required any time the KDM is used for remote reset or
 when using the CB783 Expanded Annunciator.

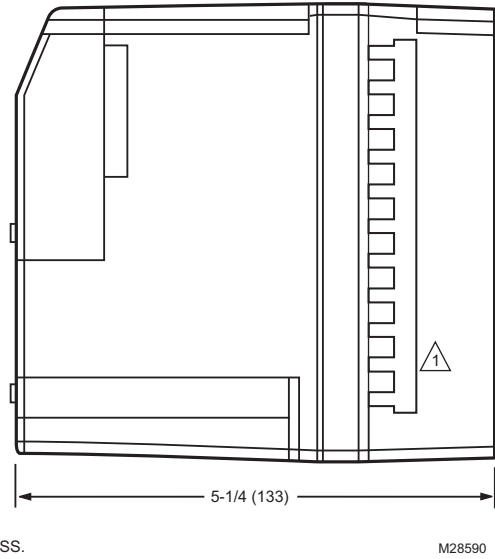
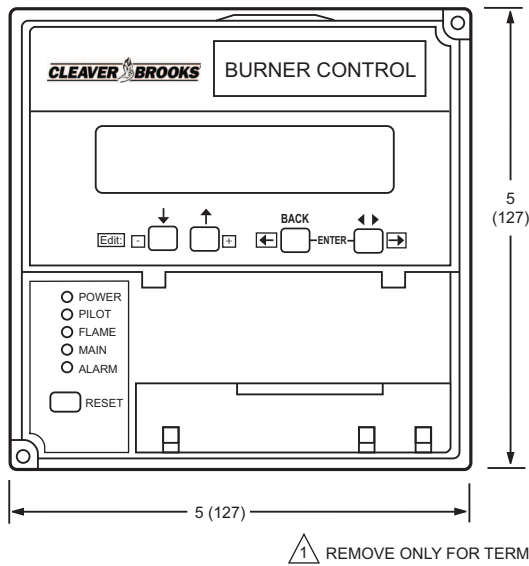

Fig. 2. Mounting dimensions of CB780E/CB784E Relay Module and 833-2725 Subbase, in inches (mm).

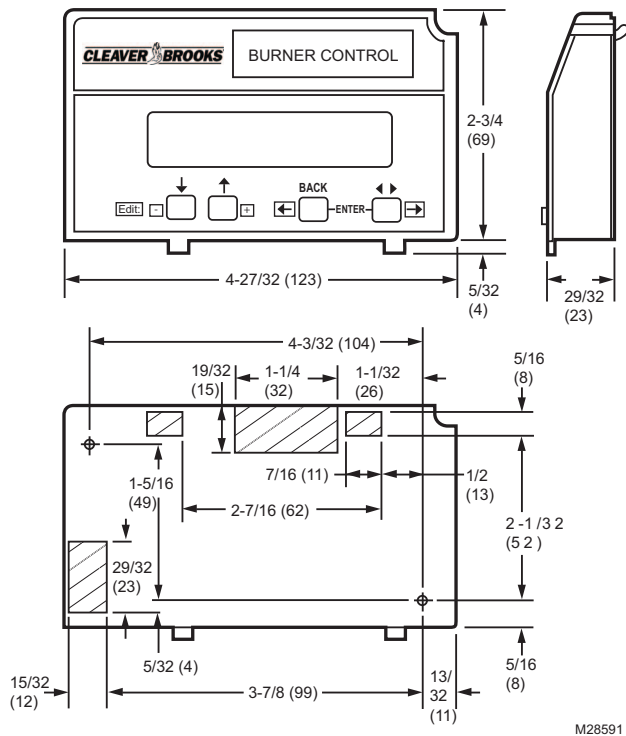

Fig. 3. Mounting dimensions of Keyboard Display Module, in inches (mm).

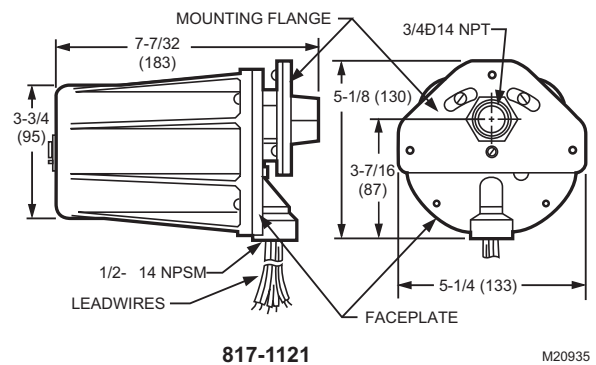

Fig. 4. Ultraviolet Self-Check detector, mounting dimensions in inches (mm).

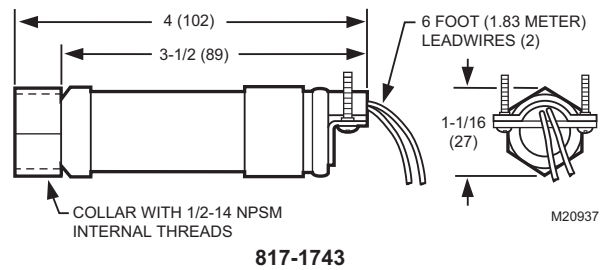

Fig. 5. Ultraviolet detector, mounting dimensions in inches (mm).

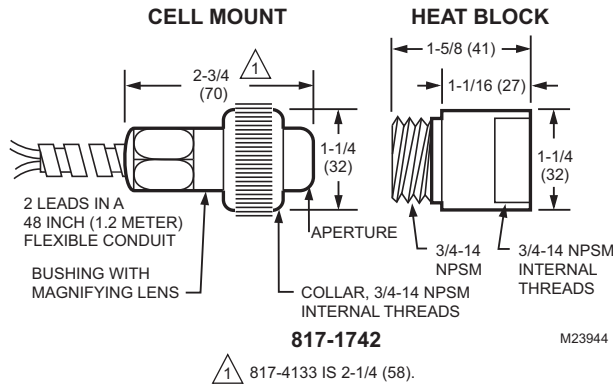

Fig. 6. Infrared detector, mounting dimensions in inches (mm).

PRINCIPAL TECHNICAL FEATURES

The CB780E/CB784E provides all customary flame safeguard functions while providing significant advancements in the areas of safety, annunciation and system diagnostics.

Safety Shutdown (Lockout) Occurs If Any of the Following Occur During the Indicated Period:

1. Anytime:
 - a. Purge card is not installed or removed.
 - b. Purge card is bad.
 - c. Configuration jumpers were changed (after 200 hours of main valve operation).
 - d. Internal system fault.
 - e. Demand present at terminals 6 and 17 at the same time.
 - f. Failure of the Valve Proving test
 - g. Demand on terminal 17 and device at default "Never".
2. INITIATE Period
 - a. AC line power errors occurred. See Operation section.
 - b. Four minute INITIATE period has been exceeded.
3. STANDBY Period
 - a. Flame signal is present after 240 seconds.
 - b. Pre-Ignition Interlock is open an accumulative time of 30 seconds.
 - c. Interlock check feature is enabled (only with JR3 clipped) and the Interlock String (including the airflow switch) is closed for 120 seconds with controller closed.
 - d. Ignition/pilot valve terminal is energized.
 - e. Main valve terminal is energized.
 - f. Internal system fault occurred.
4. PREPURGE Period
 - a. Pre-Ignition Interlock opens anytime during PREPURGE period (except during Valve Proving test).
 - b. Flame signal is detected after first ten seconds during PREPURGE.
 - c. High Fire Switch fails to close within four minutes, and fifteen seconds after firing rate motor is commanded to drive to high fire position at start of PREPURGE.

- d. Low Fire Switch fails to close within four minutes, and fifteen seconds after firing rate motor is commanded to drive to low fire position at end of PREPURGE.
 - e. Lockout Interlock does not close within 10 seconds.
 - f. Lockout Interlock opens during PREPURGE.
 - g. Ignition/pilot valve terminal is energized.
 - h. Main valve terminal is energized (except during Value Proving testing).
 - i. Internal system fault.
5. PILOT FLAME ESTABLISHING Period (PFEP)
 - a. Low Fire Switch opens.
 - b. Lockout Interlock opens.
 - c. Ignition/pilot valve terminal is not energized.
 - d. Early Spark Termination terminal is energized after five seconds.
 - e. No flame is present at end of PFEP.
 6. MAIN FLAME ESTABLISHING Period (MFEP)
 - a. Low Fire Switch opens.
 - b. Lockout Interlock opens.
 - c. Ignition/pilot valve terminal is not energized.
 - d. Main valve terminal is not energized.
 - e. No flame is present at end of MFEP.
 7. RUN Period
 - a. No flame is present.
 - b. Lockout Interlock opens.
 - c. Interrupted pilot valve terminal is energized.
 - d. Main valve terminal is not energized.
 8. POSTPURGE Period
 - a. Pre-Ignition Interlock does not close in five seconds and opens after five-second time period (except during Value Proving testing).
 - b. Ignition/pilot valve terminal is energized.
 - c. Main valve terminal is energized (except during Valve Proving testing)

SAFETY PROVISIONS

Internal Hardware Status Monitoring

The CB780E/CB784E checks the purge card for correct parity to prevent purge timing shifts and circuitry failures. It also analyzes the integrity of the configuration jumpers and internal hardware. The POWER LED blinks every four seconds, signifying an internal hardware check.

Closed Loop Logic Test

The test verifies the integrity of all safety critical loads, terminals 8, 9, 10 and 21. If the loads are not energized properly; i.e., the main valve terminal is powered during PREPURGE, the CB780E/CB784E will lockout on safety shutdown. The CB780E/CB784E must react to input changes but avoid the occurrence of *nuisance* shutdown events. Signal conditioning is applied to line voltage inputs to verify proper operation in the presence of *normal* electrical line noise such as transient high voltage spikes or short periods of line dropout. Signal conditioning is tolerant of synchronous noise (line noise events that occur at the same time during each line cycle).

Dynamic Ampli-Check™

Dynamic AMPLI-CHECK™ circuitry tests the flame signal amplifier during burner operation and shuts down the CB780E/CB784E if the flame amplifier fails.

Dynamic Flame Amplifier and Shutter Check

Self-checking circuitry tests all electronic components in the flame detection system and amplifier 10 to 12 times per minute and shuts down the CB780E/CB784E if the detection system fails.

Dynamic Input Check

All system input circuits are examined to verify that the CB780E/CB784E is capable of recognizing the true status of external controls, limits and interlocks. If any input fails this test, a safety shutdown occurs and the fault is annunciated.

Dynamic Safety Relay Test

Checks the ability of the dynamic safety relay contacts to open and close. It also verifies that the safety critical loads, terminals 8, 9, 10 and 21, can be de-energized, as required, by the Dynamic Self-Check logic.

Dynamic Self-Check Safety Circuit

The microcomputer tests itself and related hardware while at the same time the safety relay system tests the microcomputer operation. If a microcomputer or safety relay failure occurs and does not allow proper execution of the self-check routine, safety shutdown will occur and all safety critical loads will be de-energized.

Expanded Safe-Start Check

The conventional safe-start check, which prevents burner start-up if flame is indicated at start-up, is expanded to include a flame signal check during STANDBY, a preignition interlock check, an interlock check, and a safety critical load check.

High Fire Purge and Low Fire Start Switch Tests

High Fire Purge Switch Test examines the Purge Position Interlock Switch at the moment the firing rate motor is commanded to the high fire position. If the switch is bypassed, welded or otherwise closed prematurely, the system will automatically add 30 seconds to allow additional drive time for the firing rate motor to reach or near the open position before starting the purge timing; otherwise, purge timing starts when the High Fire Switch is closed. This switch will also cause a hold (four minutes, fifteen seconds) condition when the switch is open before purge or opens during purge. The CB780E/CB784E will lockout and annunciate an alarm if the switch fails to close within the hold time period.

Low Fire Start Switch Test examines the Low Fire Start Switch at the moment PREPURGE is completed. If the switch is bypassed, welded or otherwise prematurely closed, the system automatically adds 30 seconds to allow the firing rate motor additional time to reach or near the low fire start position before ignition trials; otherwise, ignition trials start after the Low Fire Switch closes. The test also is used to prove that the firing rate motor is at low fire position throughout the ignition trial period. This switch will also cause a hold (four minutes, fifteen seconds) condition if the switch opens after purging is complete. The CB780E/CB784E will lockout and annunciate an alarm if the switch fails to close within the hold time period.

Mandatory Purge

If lockout occurs after the initiation of ignition trials, (or at anytime during a sequence when the fuel valves may have been energized), a mandatory POSTPURGE period is imposed.

Off Cycle (STANDBY or PREPURGE) Flame Signal Check

The flame detection subsystem (flame detector and amplifier) is monitored during STANDBY. If a flame simulating condition or an actual flame exists, a system hold occurs and start-up is prevented. If the flame signal exists at any time after the first 40 seconds of STANDBY, a safety shutdown will occur and be annunciated. A shutter-check amplifier and self-checking detector are energized for the first 40 seconds during STANDBY and the last two seconds before exiting STANDBY. If a flame exists, a safety shutdown occurs. An AMPLI-CHECK™ Amplifier is energized continually through STANDBY and PREPURGE to detect any possibility of a runaway detector or a flame. If either situation happens, a safety shutdown occurs. A standard amplifier is energized continually through STANDBY and PREPURGE. If either situation happens, a safety shutdown occurs.

Preignition Output Circuit Check

At the end of PREPURGE, the Dynamic Safety Relay operation is checked. Also, all safety critical loads, terminals 8, 9, 10 and 21 are checked to verify the terminals are not powered. If the Dynamic Safety Relay operation is faulty, or if any of the safety critical loads are powered, safety shutdown occurs and is annunciated.

Tamper-Resistant Timing and Logic

Safety and logic timings are inaccessible and cannot be altered or defeated.

Verified Spark Termination

The ignition terminal is monitored to verify early spark termination (five seconds ignition and pilot and five seconds *pilot only*).

First-Out Annunciation and Self-Diagnostics

Sequence Status Lights (LEDs) provide positive visual indication of the program sequence: POWER, PILOT, FLAME, MAIN and ALARM. The green POWER LED blinks every four seconds to signify the CB780E/CB784E hardware is running correctly.

Multi-function Keyboard Display Module (standard with CB780E, optional with CB784E) shows elapsed time during PREPURGE, PILOT IGN, MAIN IGN, and POSTPURGE. As an additional troubleshooting aid, it provides sequence timing, diagnostic information, historical information and expanded annunciator information when a safety shutdown or hold or normal operation occurs.

First-out Annunciation reports the cause of a safety shutdown or identifies the cause of a failure to start or continue the burner control sequence with an English text and numbered code via the Keyboard Display Module. It monitors all field input circuits, including the Flame Signal Amplifier and Firing

Rate Position Switches. The system distinguishes 118 modes of failure and detects and annunciates difficult-to-find intermittent failures.

Self-Diagnostics adds to the First-out Annunciation by allowing the CB780E/CB784E to distinguish between field (external device) and internal (system related) problems. Faults associated within the flame detection subsystem, CB780E/CB784E or plug-in Purge Card, are isolated and reported by the Keyboard Display Module, see Troubleshooting section and CB780E/CB784E System Annunciation Diagnostics and Troubleshooting, Bulletin Number CB-7803.

Interlock Requirements

The following interlock inputs are provided:

Low Fire Interlock

This interlock verifies the firing rate motor is in the low fire position before and during ignition trials.

High Fire Interlock

This interlock verifies the firing rate motor is in the high fire position prior to and during PREPURGE.

Lockout Interlock

This interlock (ILK) input signifies a Lockout Interlock. If the Lockout Interlock is open for more than ten seconds into PREPURGE, the CB780E/CB784E will lockout. After entering PREPURGE, if the Lockout Interlock opens during the first ten seconds, the purge timer will be reset. This provides a continuous PURGE to occur without interruption before the Pilot Flame Establishing Period. If a Lockout Interlock opens anytime after ten seconds into PURGE, during the Ignition Trials or Run, it causes a lockout.

A typical Lockout Interlock string contains an airflow switch (see Fig. 8). The Interlock Check is a site configurable option (see Table 7). If this feature is enabled, the CB780E/CB784E will lockout after 120 seconds whenever control terminal 6 is energized, and the Lockout Interlock string (including airflow switch) is closed during STANDBY.

Preignition Interlock

The Preignition Interlock input is typically connected to proof-of-closure switches for fuel valve(s). The Preignition Interlock must be energized throughout PREPURGE. If the Preignition Interlock opens during STANDBY, it causes a hold (30 seconds). The CB780E/CB784E will lockout if the interlock does not close within 30 seconds during STANDBY. If the Preignition Interlock opens during PREPURGE, it will lockout. If the Preignition Interlock is open after five seconds into

POSTPURGE, the CB780E/CB784E will lockout. The Preignition Interlock is ignored during the ignition trials state and during RUN.

INSTALLATION

WARNING

Fire or Explosion Hazard.

Can cause severe injury, death or property damage.

To prevent possible hazardous burner operation, verification of safety requirements must be performed each time a control is installed on a burner.

When Installing This Product...

1. Read these instructions carefully. Failure to follow them could damage the product or cause a hazardous condition.
2. Check the ratings given in the instructions and marked on the product to make sure the product is suitable for the application.
3. Installer must be a trained, experienced, flame safeguard technician.
4. After installation is complete, check out the product operation as provided in these instructions.

WARNING

Electrical Shock Hazard.

Can cause severe injury, death or property damage.

Disconnect the power supply before beginning installation to prevent electrical shock, equipment and control damage. More than one power supply disconnect may be involved.

Wiring Information

1. Wiring connections for the CB780E/CB784E are unique; therefore, refer to Fig. 7–12 or the correct Specifications for proper subbase wiring.
2. Wiring must comply with all applicable codes, ordinances and regulations.
3. Wiring, where required, must comply with NEC Class 1 (Line Voltage) wiring.
4. Loads connected to the CB780E/CB784E must not exceed those listed on the CB780E/CB784E label or the Specifications, see Table 1.
5. Limits and interlocks must be rated to simultaneously carry and break current to the ignition transformer, pilot valve, and main fuel valve(s).
6. All external timers must be listed or component recognized by authorities who have jurisdiction for the specific purpose for which they are used.

IMPORTANT:

1. For on-off gas-fired systems, some authorities who have jurisdiction prohibit the wiring of any limit or operating contacts in series between the flame safeguard control and the main fuel valve(s).
2. Two Flame Detectors can be connected in parallel with the exception of Infrared Flame Detector (817-1742).
3. This equipment generates, uses and can radiate radio frequency energy and, if not installed and used in accordance with the instructions, may cause interference to radio communications. It has been tested and found to comply with the limits for a Class B computing device of Part 15 of FCC rules which are designed to provide reasonable protection against such interference when operated in a commercial environment. Operation of this equipment in a residential area may cause interference; in which case, the users at their own expense may be required to take whatever measures are required to correct this interference.
4. This digital apparatus does not exceed the Class B limits for radio noise for digital apparatus set out in the Radio Interference Regulations of the Canadian Department of Communications.

Humidity

Install the CB780E/CB784E where the relative humidity never reaches the saturation point. The CB780E/CB784E is designed to operate in a maximum 85% RH continuous, noncondensing, moisture environment. Condensing moisture may cause a safety shutdown.

Vibration

Do not install the CB780E/CB784E where it could be subjected to vibration in excess of 0.5G continuous maximum vibration.

Weather

The CB780E/CB784E is not designed to be weather tight. If installed outdoors, the CB780E/CB784E must be protected by an approved weather-tight enclosure.

Mounting Wiring Subbase

NOTE: For installation dimensions, see Fig. 2.

1. Mount the subbase in any position except horizontally with the bifurcated contacts pointing down. The standard vertical position is recommended. Any other position decreases the maximum ambient temperature rating.
2. The 833-2725 Wiring Subbase can be mounted directly in the control cabinet. Be sure to allow adequate clearance for servicing, installation, access or removal of the CB780E/CB784E, Expanded Annunciator, Keyboard Display Module, flame amplifier, flame amplifier signal voltage probes, Run/Test Switch, electrical signal voltage probes and electrical field connections.
3. For surface mounting, use the back of the subbase as a template to mark the four screw locations. Drill the pilot holes.
4. Securely mount the subbase using four no. 6 screws.

WIRING

1. Proper Wiring:
 - a. For proper subbase wiring, refer to Fig. 8.
 - b. For proper remote wiring of the Keyboard Display Module, refer to Fig. 11 or Fig. 12 to the Specifications for the Keyboard Display Module, Communication Interface Base Unit or DATA CONTROLBUS MODULE™.
2. Disconnect the power supply from the main disconnect before beginning installation to prevent electrical shock and equipment damage. More than one disconnect may be involved.
3. All wiring must comply with all applicable electrical codes, ordinances and regulations. Wiring, where required, must comply with NEC, Class 1 (Line Voltage) wiring.
4. Recommended wire size and type:
 - a. All Line Voltage terminals use no. 14 or 16 copper conductor (90°C or higher) 600 volt insulation wire (wire size must be coordinated with fuse protection). For high temperature installations, use wire selected for a temperature rating above the maximum operating temperature. All leadwires should be moisture resistant.
 - b. Keyboard Display Module—For communications purposes, use an unshielded 22 AWG 2-wire twisted cable and one wire for ground if the leadwire run and noise conditions permit; however, some installations may need up to five wires, three for communications and two for remote reset (in either a single cable or separate cables for communications or remote reset) or use Belden 8771 shielded cable or equivalent. The Keyboard Display Module, DATA CONTROLBUS MODULE™ (for remote mounting or communications) or Communication Interface ControlBus Module must be wired in a daisy chain configuration, (1(a)-1(a), 2(b)-2(b), 3(c)-3(c)). The order of interconnection of all the devices listed above is not important. Be aware that modules on the closest and farthest end of the daisy chain configuration string require a 120 ohm (1/4 watt minimum) resistor termination across terminals 1 and 2 of the electrical connectors, for connections over 100 feet, see Fig. 11–13.
 - c. DATA CONTROLBUS MODULE™—For communications purposes, use an unshielded 22 AWG 2-wire twisted cable if the leadwire run and noise conditions permit; however, some installations may need up to five wires, three for communications and two for remote reset (in either a single cable or separate cables) or use a Belden 8771 shielded cable or equivalent. The Keyboard Display Module, DATA CONTROLBUS MODULE™ (for remote mounting or communications) or Communication Interface ControlBus Module must be wired in a daisy chain configuration, (1(a)-1(a), 2(b)-2(b), 3(c)-3(c)). The order of interconnection of all the devices listed above is not important. Be aware that modules on the closest and farthest end of the daisy chain configuration string require a 120 ohm (1/4 watt minimum) resistor termination across terminals 1 and 2 of electrical connectors, for connections over 100 feet, see Fig. 11–13.

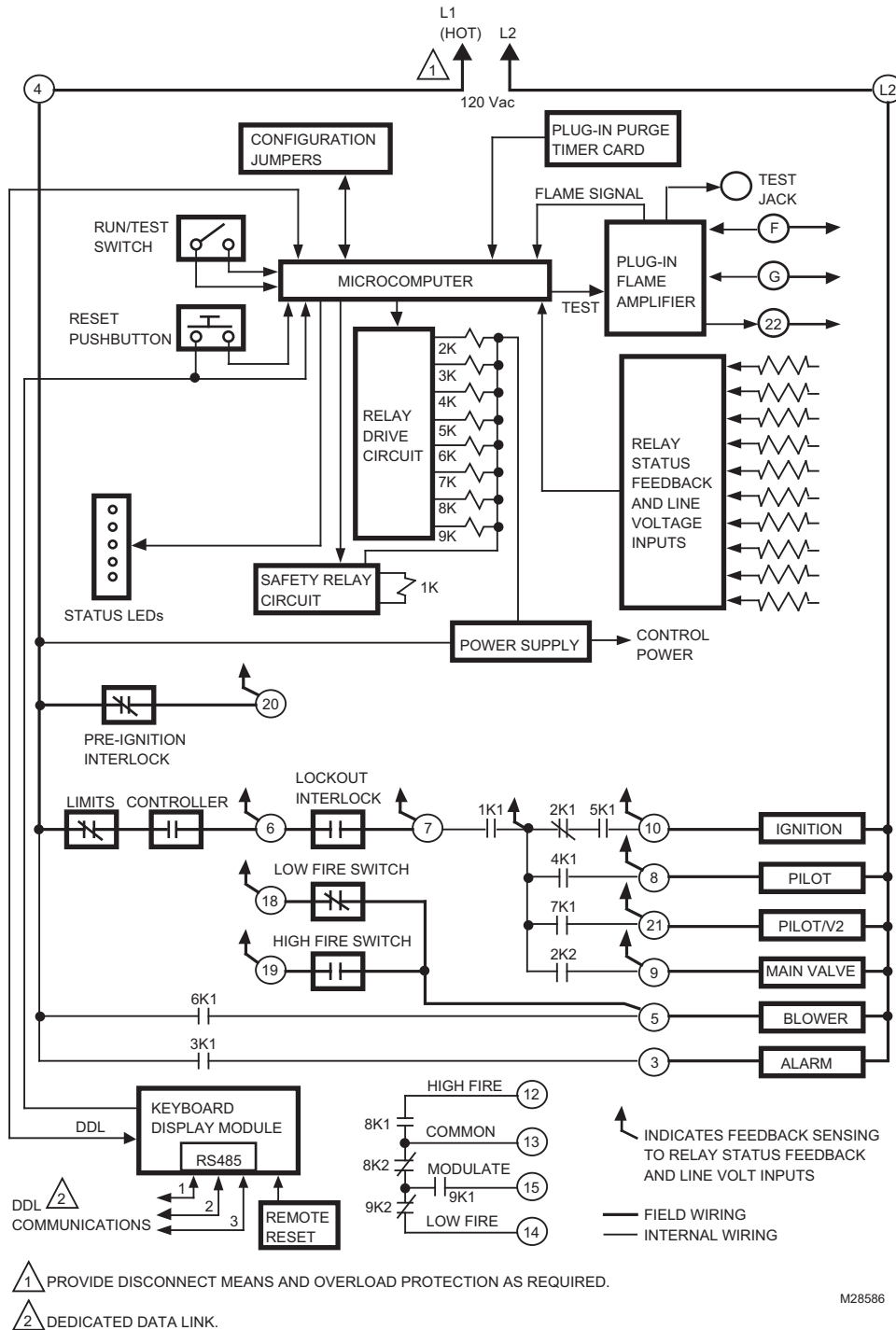
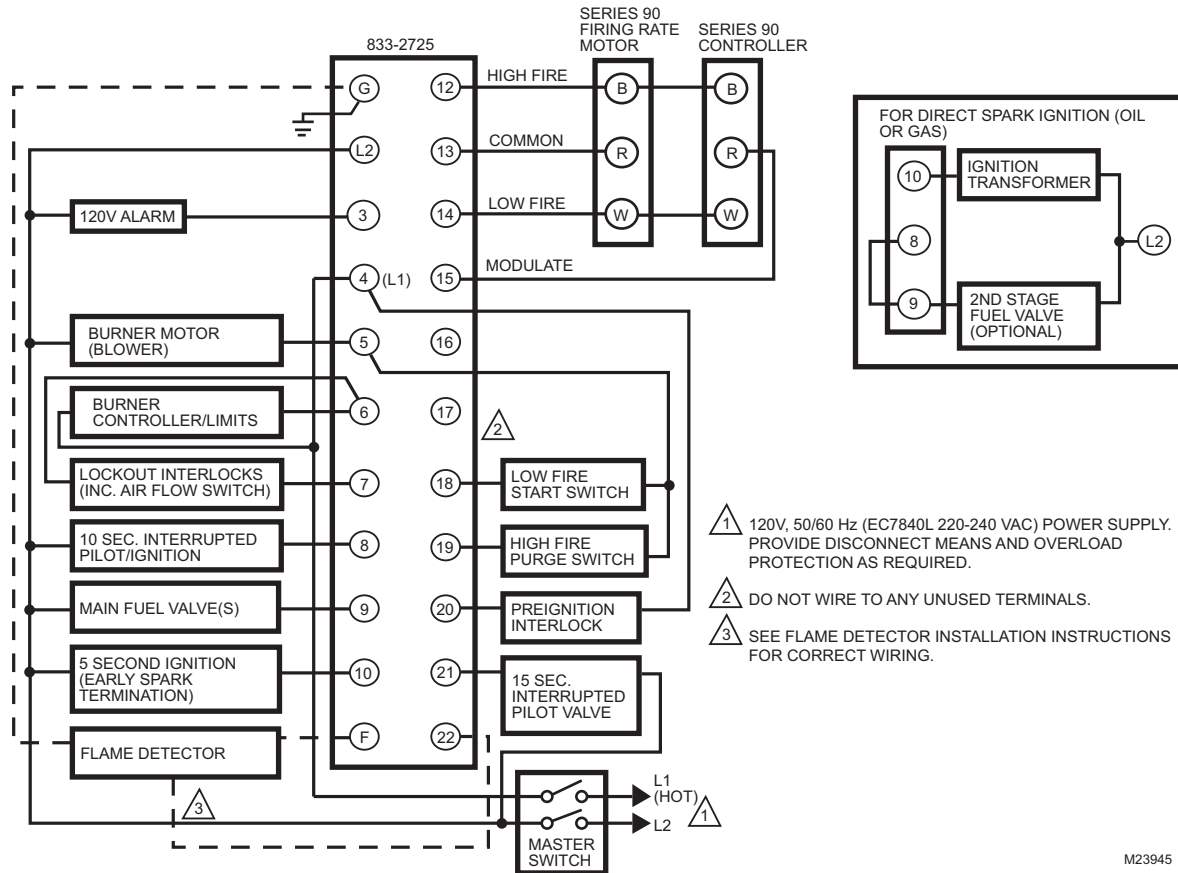

Fig. 7. Internal block diagram of the CB780E/CB784E (see Fig. 8–13 for detailed wiring instructions).

- d. Remote Reset—Use no. 22 AWG or greater twisted pair wire, insulated for low voltage; see Fig. 11–13.
- e. Communication Interface ControlBus Module—For communications purposes, use an unshielded 22 AWG 2-wire twisted cable if the leadwire run and noise conditions permit or use a Belden 8771 shielded cable or equivalent. The Keyboard Display Module, DATA CONTROLBUS MODULE™ (for remote mounting or communications) or Communi-

cation Interface ControlBus Module must be wired in a daisy chain configuration, (1(a)-1(a), 2(b)-2(b), 3(c)-3(c)). The order of interconnection of all the devices listed above is not important. Be aware that modules on the closest and farthest end of the daisy chain configuration string require a 120 ohm (1/4 watt minimum) resistor termination across terminals 1 and 2 of the electrical connectors, for connections over 100 feet, see Fig. 11–13.

- f. Use the recommended wire size for the 13 Vdc full wave rectified transformer power input of no. 18 AWG wire insulated for voltages and temperatures encountered in the application. Suggested wire types include TTW(60C), THW(75C) and THHN(90C).
- 5. Recommended grounding practices:**
- a. The earth ground provides for a connection between the subbase and the control panel of the equipment. The earth ground wire must be capable of conducting the current to blow the 20A fuse (or breaker) in event of an internal short circuit. The CB780E/CB784E needs a low impedance ground connection to the equipment frame which, in turn, needs a low impedance connection to earth ground. For a ground path to be low impedance at RF frequencies, the connection must be made with minimum length conductors that have a maximum surface area. Wide straps or brackets are preferred rather than leadwires. Be careful to ensure that mechanically tightened joints along the ground path, such as pipe or conduit threads or surfaces held together with fasteners, are free of nonconductive coatings and are protected against corrosion on mating surfaces.
 - b. Keyboard Display Module, DATA CONTROL-BUS MODULE™ or Communication Interface ControlBus Module—The shield, if used, should be connected to the signal ground terminal 3(c) provided as part of the CB780E/CB784E device ControlBus connection. Connect the shield at both ends to earth ground.
 - c. CB780E/CB784E—Each CB780E/CB784E will have an earth ground terminal that must be grounded to the metal control panel with wire as short as practical. Each ground wire must be capable of carrying a fault current equal to the rating of the protective fuse (15A maximum, Type SC or equivalent). A number 14 copper conductor is adequate, but wide straps or brackets are preferred rather than leadwires.
- 6. Recommended wire routing:**
- a. Flame detector leadwires:
 - (1) Do not run high voltage ignition transformer wires in the same conduit with the flame detection wiring.
 - (2) Do not route scanner wires in conduit with line voltage circuits.
 - (3) Enclose scanner wires without armor cable in metal cable or conduit.
 - (4) Follow directions in flame detector Instructions.
 - b. DATA CONTROLBUS MODULE™:
 - (1) Do not run high voltage ignition transformer wires in the same conduit or close proximity with the DATA CONTROLBUS MODULE™ wiring.
 - (2) Do not route DATA CONTROLBUS MODULE™ wires in conduit with line voltage circuits.
- c. Keyboard Display Module (VFD):** Because the VFD is powered from a low voltage, energy limited source, it can be mounted outside of a control panel if it is protected from mechanical damage.
- d. Remote Reset:**
- (1) Do not run high voltage ignition transformer wires in the same conduit with the Remote Reset wiring.
 - (2) Do not route Remote Reset wires in conduit with line voltage circuits.
- NOTE:** A 13 Vdc power supply must be used any time more than one Keyboard Display Module is used.
- 7. Maximum wire lengths:**
- a. CB780E/CB784E leadwires—The maximum length of leadwire is 300 feet to terminal inputs (Control, Preignition Interlock, Running/Lockout Interlock, High Fire Switch and Low Fire Switch).
 - b. Flame Detector leadwires—The maximum flame sensor leadwire length is limited by the flame signal strength.
 - c. Remote Reset leadwires—The maximum length of wire is 1000 feet to a Remote Reset pushbutton.
 - d. DATA CONTROLBUS MODULE™—The maximum DATA CONTROLBUS MODULE™ cable length depends on the number of system modules connected, the noise conditions and the cable used. The maximum length of all interconnecting wire is 1000 feet.
- 8.** Make sure loads do not exceed the terminal ratings. Refer to the label on the CB780E/CB784E or to the ratings in Specifications; see Table 1.
- 9.** Check the power supply circuit. The voltage and frequency tolerance must match those of the CB780E/CB784E. A separate power supply circuit may be required for the CB780E/CB784E. Add the required disconnect means and overload protection.
- 10.** Check all wiring circuits and complete the Static Check-out, see Table 8, before installing the CB780E/CB784E on the subbase.
- 11.** Install all electrical connectors.
- 12.** Restore power to the panel.



M23945

	INITIATE (INITIAL POWERUP ONLY)	STANDBY	PREPURGE HOLD DRIVE TO HIGH FIRE	TIMED PREPURGE	PREPURGE HOLD DRIVE TO LOW FIRE	PFEP 10 SEC. (4 SEC. IF JR1 CLIPPED)	MFEP	RUN	POSTPURGE	STANDBY
LED DISPLAY	● POWER ○ ○ ○ ○	● POWER ○ ○ ○ ○	● POWER ○ ○ ○ ○	○ PILOT ○ FLAME ○ MAIN ○ ALARM	● POWER ○ PILOT ○ FLAME ○ MAIN ○ ALARM	● POWER ● PILOT ● FLAME ○ MAIN ○ ALARM	● POWER ● PILOT ● FLAME ● MAIN ○ ALARM	● POWER ○ PILOT ● FLAME ● MAIN ○ ALARM	● POWER ○ ○ ○ ○	● POWER ○ ○ ○ ○
BURNER	BURNER/BLOWER MOTOR (5)									
	(10) IGN. 5 SEC.									
	10 SEC. IGN./PILOT (8)									
	15 SEC. PILOT (21)									
	MAIN VALVE (9)									
OPERATING CONTROLS AND INTERLOCKS	LIMITS AND BURNER CONTROLLER CLOSED (L1 TO 6)									
	INTERLOCK. CHECK LOCKOUT INTERLOCKS CLOSED (6 TO 7) IC									
	PREIGNITION INTERLOCK CLOSED (4 TO 20) PII									
	(5 TO 19) HIGH FIRE SW. LOW FIRE SW. (5 TO 18)									
FLAME SIGNAL	SAFE START CHECK FLAME PROVING SSC									
FIRING RATE MOTOR	SWITCHING (13 TO 12) MOTOR ACTION (13 TO 14) (13 TO 15) (13 TO 14)									

NOTE: SEE APPENDIX FOR APPLICATION OPTIONS.

M23946

Fig. 8. Typical wiring subbase and sequence for the CB780E/CB784E, without Valve Proving.

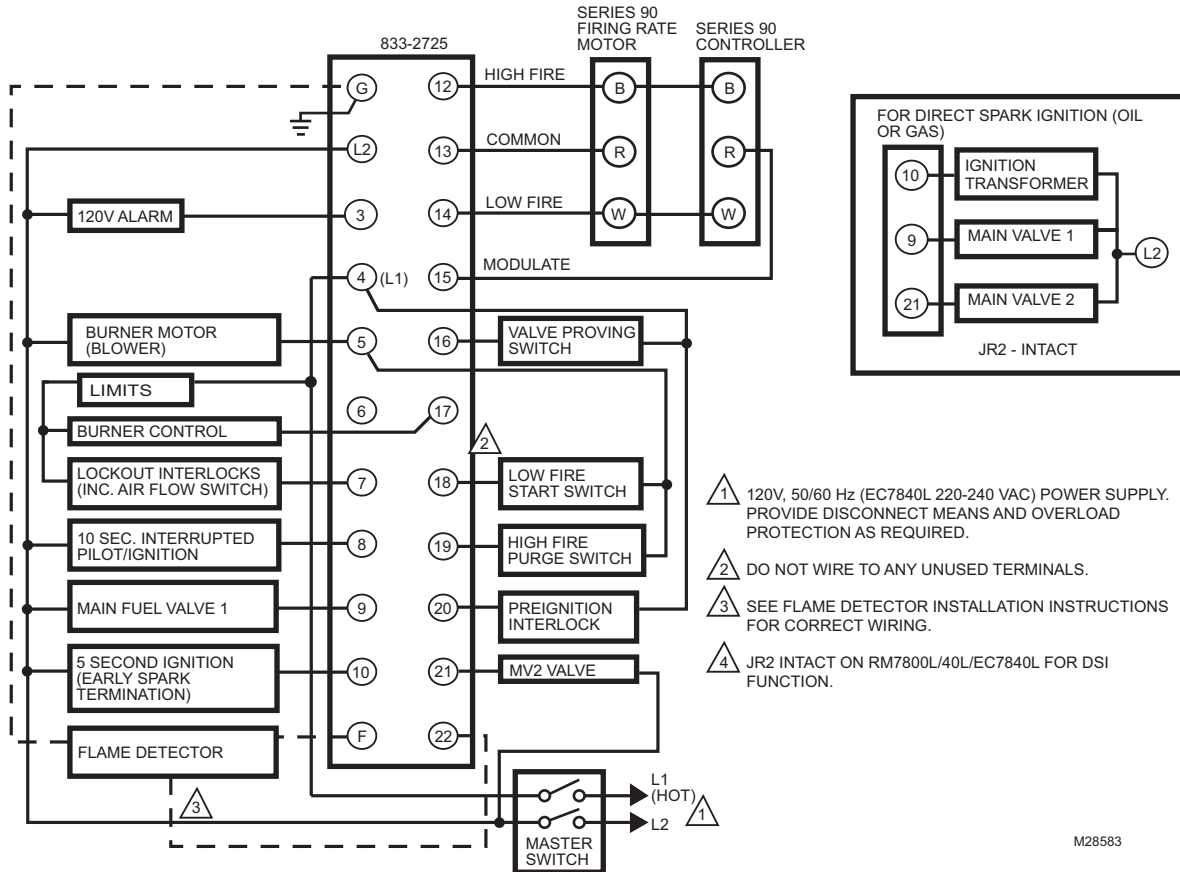

- 1 120V, 50/60 Hz (EC7840L 220-240 VAC) POWER SUPPLY. PROVIDE DISCONNECT MEANS AND OVERLOAD PROTECTION AS REQUIRED.
- 2 DO NOT WIRE TO ANY UNUSED TERMINALS.
- 3 SEE FLAME DETECTOR INSTALLATION INSTRUCTIONS FOR CORRECT WIRING.
- 4 JR2 INTACT ON RM7800L/40L/EC7840L FOR DSI FUNCTION.

M28583

	INITIATE (INITIAL POWERUP ONLY)	STANDBY	PREPURGE HOLD DRIVE TO HIGH FIRE	PREPURGE TIMED PREPURGE	PREPURGE HOLD DRIVE TO LOW FIRE	PFEP 10 SEC. (4 SEC. IF JR1 CLIPPED)	10 MFEP	20	25	00 RUN	POSTPURGE	15 STANDBY
LED DISPLAY	● POWER	● POWER	● POWER	● POWER	● POWER	● POWER	● POWER	● POWER	● POWER	● POWER	● POWER	● POWER
	○	○	○	○ PILOT	○ PILOT	● PILOT	● PILOT	○ PILOT	○	○	○	○
	○	○	○	○ FLAME	○ FLAME	● FLAME	● FLAME	● FLAME	○	○	○	○
	○	○	○	○ MAIN	○ MAIN	○ MAIN	● MAIN	● MAIN	○	○	○	○
	○	○	○	○ ALARM	○ ALARM	○ ALARM	○ ALARM	○ ALARM	○	○	○	○
BURNER			BURNER/BLOWER MOTOR (5)									
					(10) IGN. 5 SEC.							
						10 SEC. IGN./PILOT (8)		△ 2				
								MV2 (21)		△ 1		
								MAIN VALVE (9)				
OPERATING CONTROLS AND INTERLOCKS			LIMITS AND BURNER CONTROLLER CLOSED (L1 TO 17)									
	INTERLOCK. CHECK		LOCKOUT INTERLOCKS CLOSED (7)									IC
			PREIGNITION INTERLOCK CLOSED (4 TO 20)									PII
			(5) TO (19) HIGH FIRE SW.		LOW FIRE SW. (5) TO (18)							
FLAME SIGNAL	SAFE START CHECK						FLAME PROVING				SSC	
			SWITCHING									
FIRING RATE MOTOR			(13) TO (12)				(13) TO (14)		(13) TO (15)		(13) TO (14)	
			MOTOR ACTION									

- △ 1 MV2 IS MAIN VALVE CLOSEST TO THE BURNER.
- △ 2 JR2 REMOVED FOR PILOT SEQUENCE.

M24790

Fig. 9. Typical wiring subbase and sequence for the CB780E/CB784E, with Valve Proving enabled.

CB780E/CB784E RELAY MODULES WITH VALVE PROVING INSTALLATION AND OPERATING INSTRUCTIONS

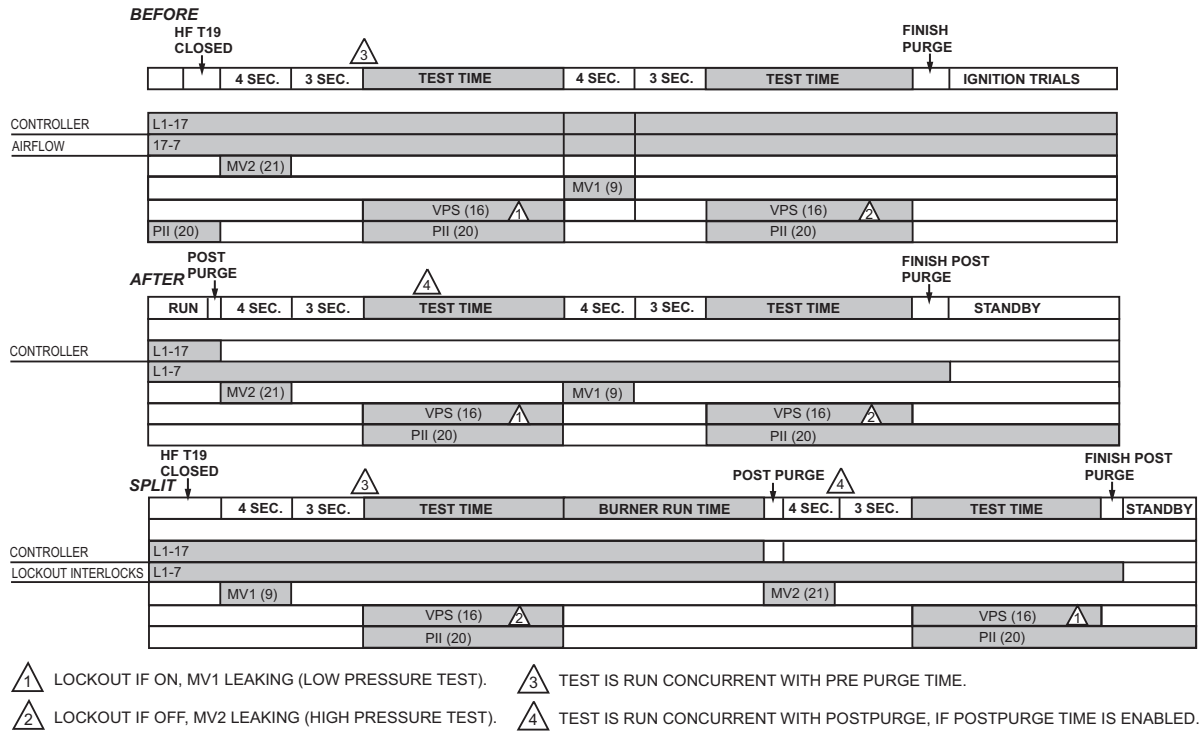

M24791

Fig. 10. CB780E/CB784E Relay Module operation, Valve Proving test options.

833-2727 KEYBOARD DISPLAY MODULE (MOUNTED ON CB 780/CB 784 RELAY MODULE)

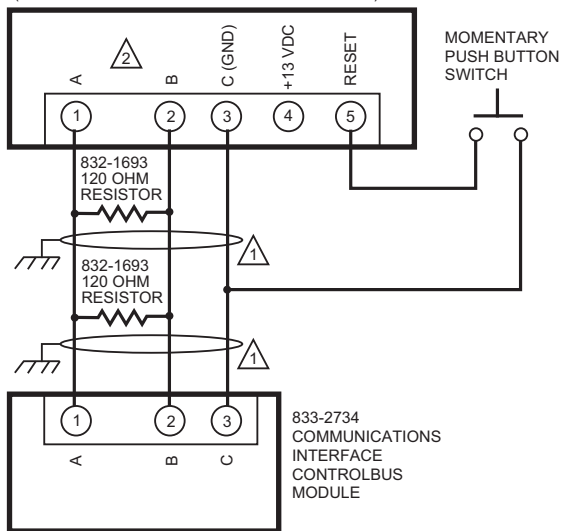

- 1 THREE WIRE SHIELDED CABLE MAY BE REQUIRED. TWO 832-1693 120 OHM TERMINATING RESISTORS ARE REQUIRED FOR CONNECTIONS OVER 100 FEET (30 METERS). CABLE SHIELD MUST BE TERMINATED TO EARTH GROUND AT BOTH ENDS. IF SHIELDED CABLE IS NOT USED, TWISTED PAIR WIRE MUST BE USED.
- 2 TERMINALS OF 203541 5-WIRE CONNECTOR.

M28584

Fig. 11. Wiring the Keyboard Display Module with Communications Interface ControlBus Module.

833-2727 KEYBOARD DISPLAY MODULE (MOUNTED ON CB 780/CB 784 RELAY MODULE)

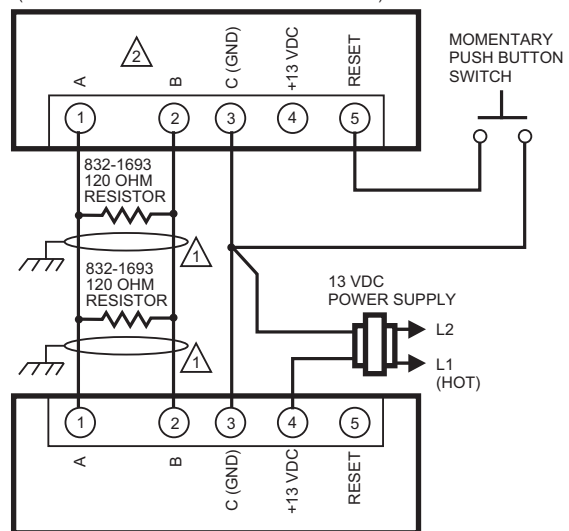

- 1 THREE WIRE SHIELDED CABLE MAY BE REQUIRED. TWO 120 OHM TERMINATING RESISTORS ARE REQUIRED FOR CONNECTIONS OVER 100 FEET. CABLE SHIELD MUST BE TERMINATED TO EARTH GROUND AT BOTH ENDS. IF SHIELDED CABLE IS NOT USED, TWISTED PAIR WIRE MUST BE USED.
- 2 TERMINALS OF 203541 5-WIRE CONNECTOR.

M28585

Fig. 12. Wiring multiple Keyboard Display Modules.

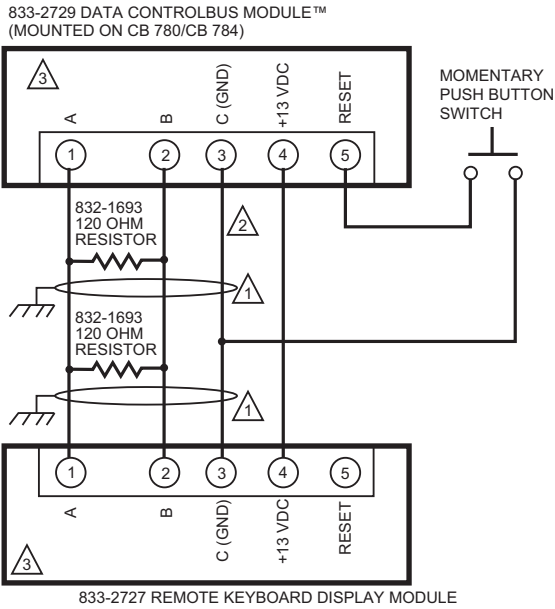

- 1 THREE WIRE SHIELDED CABLE MAY BE REQUIRED. TWO 832-1693 120 OHM TERMINATING RESISTORS ARE REQUIRED FOR CONNECTIONS OVER 100 FEET. CABLE SHIELD MUST BE TERMINATED TO EARTH GROUND AT BOTH ENDS. IF SHIELDED CABLE IS NOT USED, TWISTED PAIR WIRE MUST BE USED.
- 2 WHEN CONNECTING THE KEYBOARD DISPLAY MODULE DATA CONTROLBUS MODULE™, OR REMOTE RESET MODULE EXTERNAL FROM THE CONTROL CABINET, APPROPRIATE MEASURES MUST BE TAKEN TO MEET EN60730 SAFETY LOW VOLTAGE REQUIREMENTS (SEE APPROVALS).
- 3 TERMINALS ARE ON 5-WIRE CONNECTOR 203541.

M28587

Fig. 13. Wiring the Data ControlBus™ Module with Remote Keyboard Display Module.

ASSEMBLY

Mounting CB780E/CB784E Relay Modules

NOTE: For installation dimensions, see Fig. 2.

Relay Module Mounting

- Mount the CB780E/CB784E vertically. See Fig. 14 or mount horizontally with the knife blade terminals pointing downward. The CB780E/CB784E must be in an electrical enclosure.
- Select the location in the electrical enclosure. Be sure to allow adequate clearance for servicing, installation and removal of the CB780E/CB784E, Keyboard Display Module, flame amplifier, flame amplifier signal voltage probes, electrical signal voltage probes, and electrical connections.
 - Allow an additional two inches below the CB780E/CB784E for the flame amplifier mounting.
 - Allow an optional three-inch minimum to both sides of the CB780E/CB784E for electrical signal voltage probes.
- Make sure no subbase wiring is projecting beyond the terminal blocks. Tuck wiring in against the back of the subbase so it does not interfere with the knife blade terminals or bifurcated contacts.

IMPORTANT:

The CB780E/CB784E must be installed with a plug-in motion rather than a hinge action.

- Mount the CB780E/CB784E by aligning the four L-shaped corner guides and knife blade terminals with the bifurcated contacts on the wiring subbase and tightening the two screws securely without deforming the plastic.

Installing the Purge Card

- Remove the Keyboard Display Module or DATA CONTROLBUS MODULE™, see Fig. 16 or 17.
- Remove the current Purge Card from the CB780E/CB784E by pulling the plastic support cover upward.
- Make sure that the Purge Card selected has the desired timing.
- Insert Purge Card into the opening of the CB780E/CB784E compartment, see Fig. 15
- Reinstall the Keyboard Display Module or DATA CONTROLBUS MODULE™ onto the CB780E/CB784E and restore power to the device.
- Run the burner system through at least one complete cycle to verify the system is operating as desired.



Fig. 14. Electrical panel installation.

IMPORTANT:

The CB780E will not function properly without one of the following mounted correctly: Keyboard Display Module, or DATA CONTROLBUS MODULE™.

Mounting Keyboard Display Module

- Align the two interlocking ears of the Keyboard Display Module with the two mating slots on the CB780E/CB784E; see Fig. 16.
- Insert the two interlocking ears into the two mating slots and with a hinge action push on the lower corners of the Keyboard Display Module to secure it to the CB780E/CB784E.
- Verify the Keyboard Display Module is firmly in place.

Mounting Data ControlBus™ Module

1. Align the two interlocking ears with the two mating slots on the CB780E/CB784E; see Fig. 17.
2. Insert the two interlocking ears into the two mating slots and push on the lower corners of the DATA CONTROLBUS MODULE™ to secure it to the CB780E/CB784E.
3. Be sure the DATA CONTROLBUS MODULE™ is firmly in place.

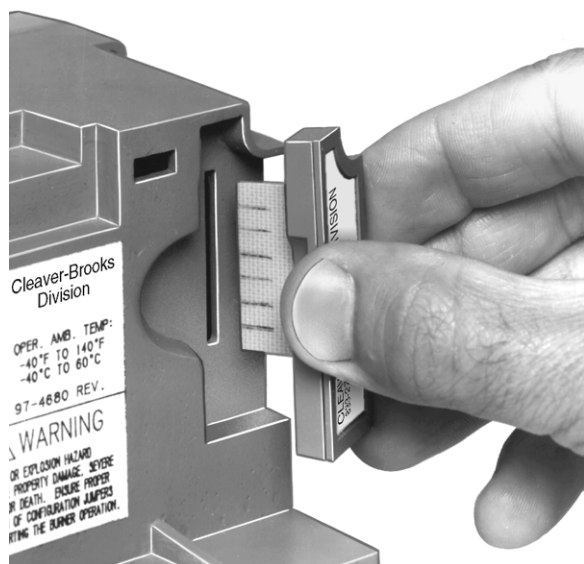

Fig. 15. Purge card installation.



Fig. 16. Keyboard Display Module installation.



Fig. 17. Data ControlBus™ mounting.

Remote Mounting of Keyboard Display Module.

1. The Keyboard Display Module can be mounted either on the face of a panel door or on other remote locations; see Fig. 18.
2. When mounting the Keyboard Display Module on the face of a door panel, closely follow these instructions:
 - a. Select the location on the door panel for flush mounting. Pay attention to the insertion dimension of the two Keyboard Display Module screws, two interlocking ears and the two plug-in connectors to allow for sufficient clearance, 1/4 inch minimum inward from the surface of the door panel.
 - b. Use the Keyboard Display Module as a template; see Fig. 50. Mark the two screw locations, two interlocking ear locations and two plug-in connector locations. Drill the pilot holes for the mounting screws. Provide for two holes on the door panel for the interlocking ears and plug-in connector holes.
 - c. Mount the Keyboard Display Module securing the two no. 4 screws.
3. A second Keyboard Display Module or a Data ControlBus™ Module must be installed on the CB780E/CB784E. Connections from the module to the remote display are completed following wiring shown in Fig. 11–13.

Installing Plug-In Flame Signal Amplifier

1. Disconnect power supply before beginning installation to prevent electrical shock and equipment damage. More than one disconnect may be involved.
2. Align the amplifier circuit board edge connector with the keyed receptacle on the CB780E/CB784E. Verify the amplifier nameplate faces away from the Relay Module, see Fig. 19.
3. Push in the amplifier until the circuit board is fully inserted into the receptacle and then push the amplifier toward the CB780E/CB784E retaining clasp.
4. Verify the amplifier is firmly in place.
5. Perform all required checkout tests.

Installing the Flame Detector

NOTE: Table 5 lists the flame detection systems available for use with the CB780E/CB784E. Make sure the correct combination of amplifier and flame detector(s) is used.

Proper flame detector installation is the basis of a safe and reliable flame safeguard installation. Refer to the instructions packed with the flame detector and the equipment manufacturer instructions; see Fig. 20.

Keep the flame signal leadwires as short as possible from the flame detector to the wiring subbase. Capacitance increases with leadwire length, reducing the signal strength. The maximum permissible leadwire length depends on the type of flame detector, leadwire and conduit. The ultimate limiting factor in the flame detector leadwire is the flame signal; see Table .



Fig. 19. Flame signal amplifier mounting.



Fig. 18. Remote mounting of Keyboard Display Module.

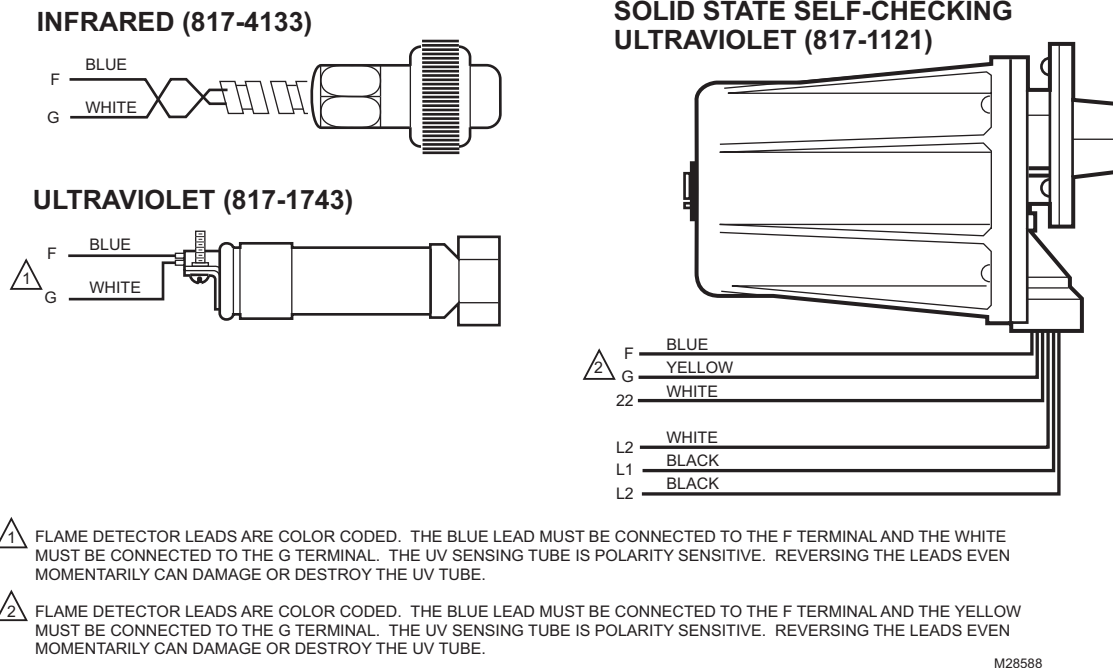

Fig. 20. Flame detector wiring.

VALVE PROVING SYSTEM

The Valve Proving System feature provides a systematic way of testing the valve seat integrity to assure the valves are in the closed state whenever the sequence of operation requires them to be closed. It is designed to detect a leak greater than 0.1% of the burner input capacity. For example, a 10 million Btu/hr natural gas-fueled burner would have a fuel input capacity of approximately 1,000 ft³/hr. A leak rate greater than 0.1% of 1,000 ft³/hr or 1 ft³/hr in either valve will be detected with the Valve Proving System. Smaller leaks will not be detected.

At commissioning time, the Valve Proving System may be scheduled to occur at one of five different times: Never, Before, After, Both, and Split.

Never—Device default as received: in this case Valve Proving does not occur.

Before—Valve Proving occurs concurrently with Pre-Purge.

After—Valve Proving occurs after the Run state before the internal Safety Relay dropout state and concurrent with Post Purge (if configured).

Both—Valve proving occurs at both times Before and After noted above.

Split—The downstream seat (high pressure) test is performed at the Before time and the upstream seat (low pressure) test is performed during the After time.

The Valve Proving items programmed are:

1. Specify when to perform Valve Proving. Demand input to terminal 17 actually enables the function of Valve Proving.
2. Specify the time duration of the test (calculated from Appendix A).

Typical Valve Proving System Function

Valve proving consists of monitoring the pressure in the space between two shutoff valves, MV1 (upstream) and MV2 (downstream). The valve proving function, identified by letters A through F, operates as follows:

The tolerance on all valve proving timing values is $\pm 10\%$.

The following are steps performed during valve proving tests. This section is for background information and does not define the exact behavioral requirements.

- A.** MV2 is commanded to be open while MV1 remains closed; to depressurize the space. After 4 seconds, MV2 is commanded closed again.
- B.** This is followed by a three second delay during which the valve proving pressure switch (VPS) is ignored.
- C.** Thereafter, the VPS is monitored for the duration of the valve proving test time and, if it turns on, then a lockout occurs. (Because the gas pressure has increased due to a leaky upstream valve.) (Low pressure test.)

D. MV1 is commanded to be open while MV2 remains closed, to pressurize the space. After 4 seconds, MV1 is commanded closed again.

E. This is followed by a three second delay, during which the valve proving pressure switch (VPS) is ignored.

F. Thereafter, the VPS is monitored for the duration of the valve proving test time and, if it turns off, then a lockout occurs. (Because the gas pressure has decreased due to a leaky downstream valve.) (High pressure test.)

Pressure Switches for Valve Proving System

The Valve Proving System requires a pressure switch to be installed to monitor the pressure in the internal space between the two shutoff valves. Recommended pressure switches are the following Honeywell non-manual reset models:

Table 6. Honeywell Pressure Switch Selection for Valve Proving System

1	2	3	4	5	6
Model Number	Operating Pressure Range	Maximum Differential (Additive)	Maximum Continuous Rated Pressure (psi)	Switch Action at Setpoint	Mounting Type
C6097A1004	0.4 to 5 in. wc	0.24 in. wc	2.9	Breaks N.O. to C connection on pressure fall.	1/4-in. NPT
C6097A1053	3 to 21 in. wc	0.48 in. wc	5.0		Flange
C6097A1061					1/4 in. NPT
C6097A1079	12 to 60 in. wc	2.4 in. wc	9.3		Flange
C6097A1087					1/4 in. NPT
C6097A1129	1.5 to 7 psi	0.3 psi	2.9		Flange
C6097A1137					
C6097A1210	0.4 to 4 in. wc	0.24 in. wc			

Pressure Switch Selection

- Determine the maximum operating inlet pressure for the upstream valve; for example, 5.0 psi (140 in. wc).
- Divide the inlet pressure by two (2.5 psi [70 in. wc], for example).
- From column 2 in Table 6 find the operating range upper limit that is closest to but greater than the inlet pressure divided by two. In the example given, the possible selections from column 1 are the C6097A1129 and C6097A1137 with an operating range upper limit of 7 psi. (The C6097A1079 and C6097A1087 with an upper limit of 60 in. wc are close, but 60 in. wc is less than the 70 in. wc minimum, so the next higher range must be selected.)
- From column 6, select the preferred mounting type, 1/4 in. NPT or Flange. For example, if a flange mount is required, the pressure switch choice from column 1 would be the C6097A1137.

Pressure Switch Installation and Adjustment

- Refer to the instructions for the C6097A Pressure Switch, form number 65-0237.
- Install the C6097A Pressure Switch according to the instructions.
- Adjust the setpoint to 50% of the maximum operating inlet pressure for the upstream valve.
- Complete the operation and checkout procedures in the instructions.

Setup (Programming) of Valve Proving Function

Prior to setup of the Valve Proving Function, follow the procedures in the appendix to complete the worksheet and obtain the Valve Proving Test Time.

The 833-2727 Keyboard Display Module (KDM) is required for this setup.

System operation requires the Valve Proving function setup and demand input must be connected to terminal 17.

NOTE: The 833-2727 Keyboard Display is NOT supplied on the CB784E device.

When the CB780E/CB784E is installed and powered, "STANDBY" will be shown on the first line of the display.

1. Scroll down until the "Setup" is displayed in the second line. (Setup is only available when the control is in Standby or Lockout state.)

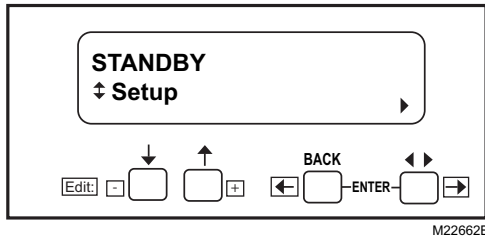

Fig. 21. STANDBY/Setup screen.

2. Enter the Setup submenu by pressing the far right key on the display. Note that the second line now reads "BC Password".

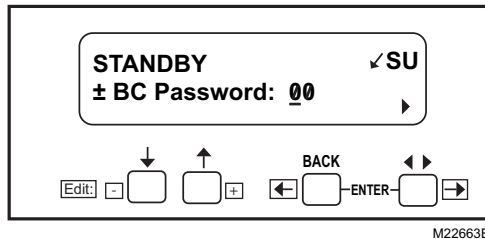

Fig. 22. Password screen.

3. Use the +/- buttons to enter the first number—7.
4. Use the far right key to shift over one space.
5. Use the +/- buttons to enter the second number—8.
6. Press Enter (left/right arrow simultaneously).

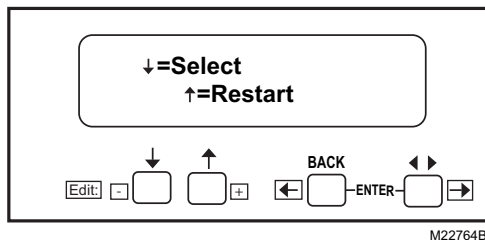

Fig. 23. Select/Restart screen.

7. To get to the next screen, press the down arrow. "Getting Data" will be displayed, then the following screen.

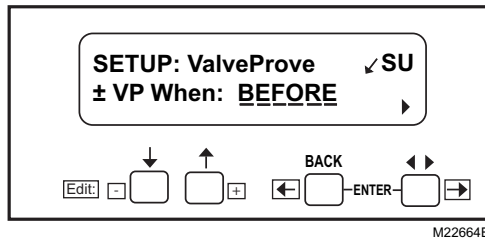

Fig. 24. SETUP: Valve Prove screen.

NOTE: This screen sets up when to do the Valve Proving Test.

8. Use the up/down arrows to select from Never, Before, After, Both, or Split, then press ENTER.

NOTE: Use Never (as shipped) on initial startup so gas line purging and System Checkout can be performed. Then come back to set final operation configuration. Be sure to conduct final VPS System checkout when Setup is complete.

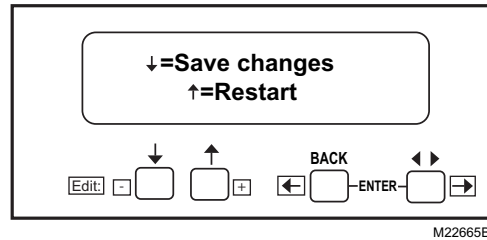

Fig. 25. Save Changes screen.

9. Use the down arrow to save changes. After pressing the down arrow, "Getting Data" is displayed.

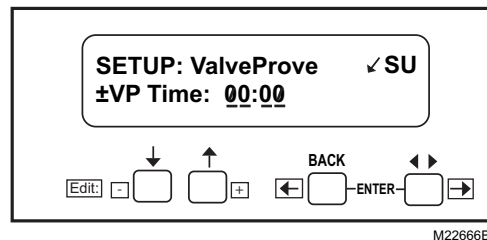

Fig. 26. Valve Prove time screen.

This screen sets up how long the CB780E/CB784E will conduct the Valve Proving Test for a given time. VP Time: 00:00 is shown.

10. Enter the appropriate Valve Proving test time from the worksheet in the appendix.

Use the (+) button to increase time and the (-) button to decrease. Time changes:

- a. 0 to 60 seconds in 1-second intervals.
- b. 60 to 600 seconds in 10-second intervals.
- c. 10 to 60 minutes in 1-minute intervals.

Press ENTER when correct time is displayed.

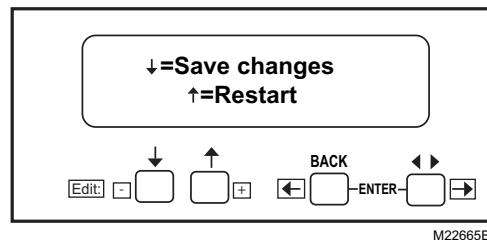

Fig. 27. Save Changes screen.

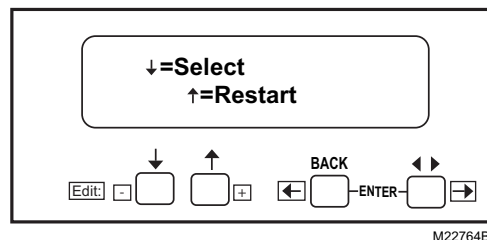

Fig. 28. Select/Restart screen.

11. Press down arrow to select.
12. "Getting Data" will be momentarily displayed, followed by the screen shown in Fig. 24.

Changing the Installed Postpurge

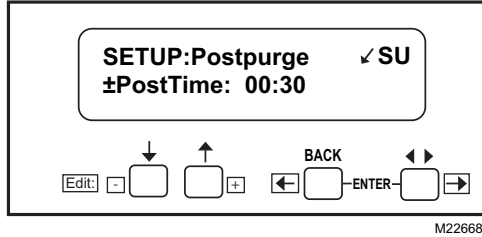

Fig. 29. Setting Postpurge time.

This screen allows for setting up the Postpurge for the CB780E/CB784E. This will be the time that the Combustion Fan (terminal 5) will remain energized after the demand ends.

NOTE: The device comes standard with 15-second Post-purge.

13. Use the +/- buttons to adjust the postpurge time. Time changes:
 - 0 to 60 seconds in 1-second intervals.
 - 60 to 600 seconds in 10-second intervals.
 - 10 to 60 minutes in 1-minute intervals.
14. Press Enter (Left/Right arrow keys simultaneously) when the correct postpurge time is displayed.

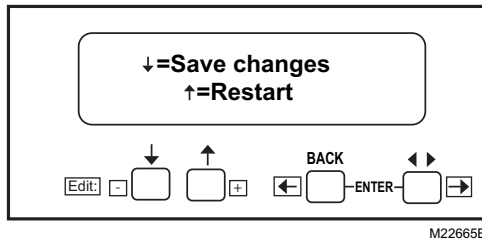

Fig. 30. Save Changes screen.

15. Use the down arrow to save changes. "Getting Data" is displayed momentarily. The following steps are to confirm your selections.

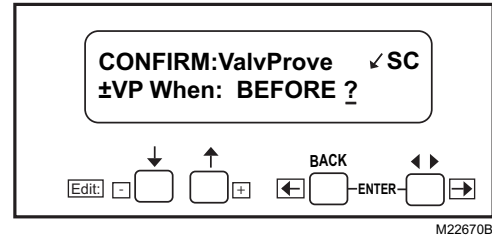

Fig. 31. Confirmation Acknowledgement screen. (The Valve Proving Test location is shown.)

16. Press ENTER.

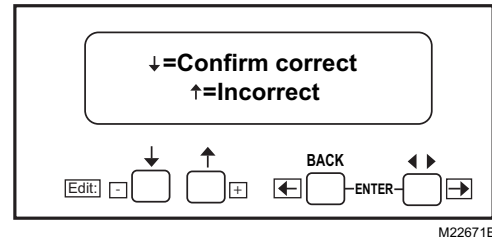

Fig. 32. Confirmation Correct screen.

17. Use the down arrow to confirm correct.

NOTE: Using the up arrow during this step will take you back to the beginning of the setup routine.

"Getting Data" will be displayed.

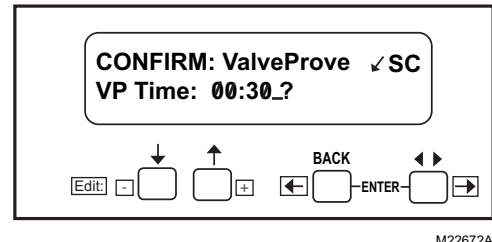

Fig. 33. Confirm screen.

18. Press Enter.

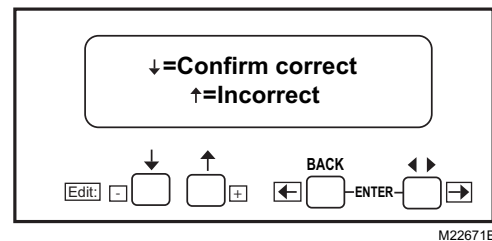

Fig. 34. Confirm Correct screen.

- Use the down arrow to confirm correct. "Getting Data" will be displayed.

The following steps are used to confirm your selection.

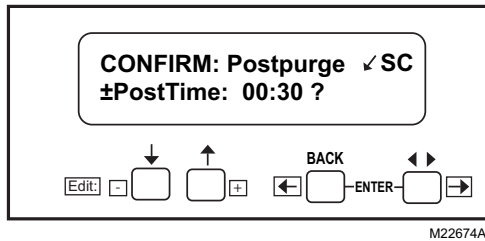

Fig. 35. Confirm Postpurge time.

- Press Enter.

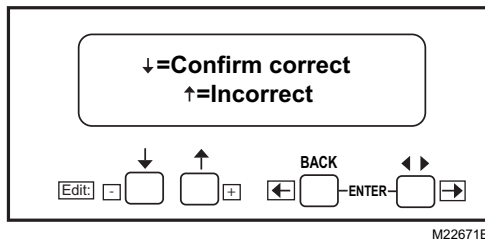

Fig. 36. Confirm correct/incorrect screen.

- Press Enter.
- Press the down arrow to confirm the correct postpurge time. "Getting Data" will be displayed until the screen in Fig. 32 appears.

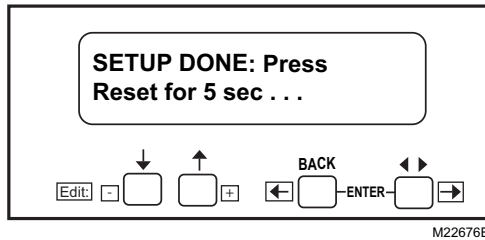

Fig. 37. Setup Done screen.

- Press and hold the relay module RESET button for five seconds to program the Valve Proving setup into the relay module.

The Release Reset screen will appear on the KDM.

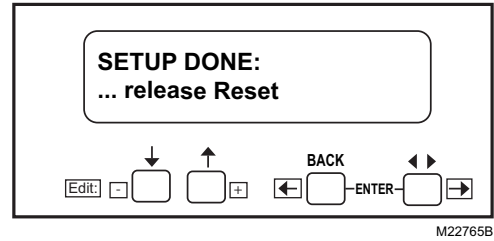

Fig. 38. Release Reset screen.

Once the system is in operation, the settings of the Valve Proving and Postpurge can be viewed in Diagnostics, using your 833-2727 Keyboard Display Module (KDM).

Future changes to the Valve Proving and Postpurge features are still possible. With the relay module in standby, scroll to the Setup line and enter the password to change the settings.

SETTINGS AND ADJUSTMENTS

Selectable Site-Configurable Jumpers

The CB780E/CB784E has three site-configurable jumper options, see Fig. 39 and Table 7. If necessary, clip the site-configurable jumpers with side cutters and remove the resistors from the Relay Module.

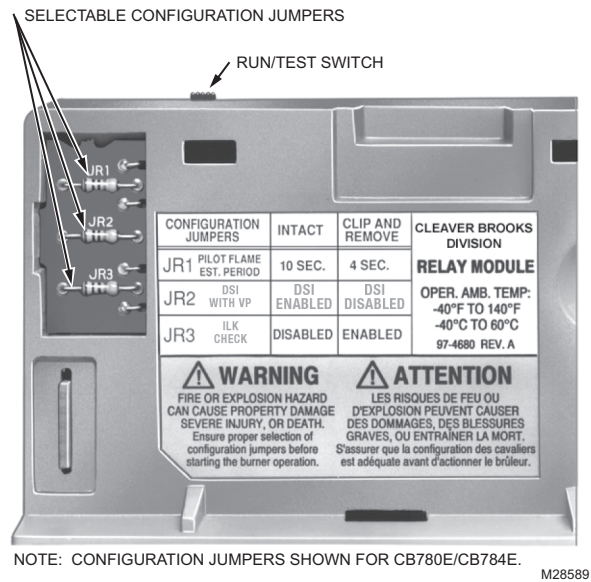

NOTE: CONFIGURATION JUMPERS SHOWN FOR CB780E/CB784E.

Fig. 39. Selectable site-configurable jumpers.

Table 7. Site Configurable Jumper Options

Jumper Number	Description	Intact	Clipped
JR1	Pilot Flame Establishing Period ^a	10 seconds	4 seconds
JR2	DSI with Valve Proving ^a	Enabled	Disabled
JR3	Start-Up Interlock Check	Disabled	Enabled

^a DSI Enabled allows for Valve Proving test to be performed, then during PFEP both terminals 9 and 21 energize to light the Main Flame. NOTE: PFEP will not occur and MFEP will automatically be 4 seconds, regardless.

STATIC CHECKOUT

After checking all wiring, perform this checkout before installing the CB780E/CB784E on the subbase. These tests verify the Q7800 Wiring Subbase is wired correctly, and the external controllers, limits, interlocks, actuators, valves, transformers, motors and other devices are operating properly.

WARNING

Explosion and Electrical Shock Hazard.
Can cause serious injury, death or equipment damage.

1. Close all manual fuel shutoff valve(s) before starting these tests.
2. Use extreme care while testing the system. Line voltage is present on most terminal connections when power is on.
3. Open the master switch before installing or removing a jumper on the subbase.
4. Before continuing to the next test, be sure to remove test jumper(s) used in the previous test.
5. Replace all limits and interlocks that are not operating properly. Do not bypass limits and interlocks.

CAUTION

Equipment Damage Hazard.
Improper testing can damage equipment.
Internal surge protectors can break down and conduct a current, causing the CB780E/CB784E to fail the dielectric test or possibly destroy the internal lightning and high current protection. Do not perform a dielectric test with the CB780E/CB784E installed.

Equipment Recommended

1. Voltmeter (1M ohm/volt minimum sensitivity) set on the 0-300 Vac scale.
2. Two jumper wires; no. 14 wire, insulated, 12 inches (304.8 mm) long with insulated alligator clips at both ends.

3. Ammeter can be used to verify valve loads connected to the wiring subbase.

General Instructions

1. Perform all applicable tests listed in Static Checkout, Table 8, in the order listed.
2. Make sure all manual fuel shutoff valve(s) are closed.
3. Perform only those tests designated for the specific CB780E or CB784E model being tested.
4. Raise the setpoint of the operating controller to simulate a call for heat.
5. For each test, open the master switch and install the jumper wire(s) between the subbase wiring terminals listed in the Test Jumpers column.
6. Close the master switch before observing operation.
7. Read the voltage between the subbase wiring terminals listed in the Voltmeter column.
8. If there is no voltage or the operation is abnormal, check the circuits and external devices as described in the last column.
9. Check all wiring for correct connections, tight terminal screws, correct wire, and proper wiring techniques. Replace all damaged or incorrectly sized wires.
10. Replace faulty controllers, limits, interlocks, actuators, valves, transformers, motors and other devices as required.
11. Make sure normal operation is obtained for each required test before continuing the checkout.
12. After completing each test, be sure to remove the test jumper(s).

WARNING

Explosion Hazard.
Can cause serious injury or death.
Make sure all manual fuel shutoff valves are closed before performing static checkout.

Table 8. Static Checkout.

Test No.	CB780E/ CB784E Models	Test Jumpers	Voltmeter	Normal Operation	If Operation is Abnormal, Check the Items Listed Below
1	All	None	4-L2	Line voltage at Terminal 4.	1. Master Switch. 2. Power connected to the Master Switch. 3. Overload protection (fuse, circuit breaker, etc.) has not opened the power line.
2	All		6-L2 17-L2	Line voltage at Terminal 6. For VP applications. (Terminal 17)	1. Limits. 2. Burner Controller.
3	All		16-L2	Line voltage at 16	Valve Proving switch.
4	All		20-L2	Line voltage at Terminal 20.	1. Pre-Ignition interlocks.

Table 8. Static Checkout. (Continued)

Test No.	CB780E/ CB784E Models	Test Jumpers	Voltmeter	Normal Operation	If Operation is Abnormal, Check the Items Listed Below
5	All	4-5	7-L2	1. Burner motor (fan or blower) starts. 2. Line voltage at Terminal 7 within 10 seconds.	1. Burner motor circuit. a. Manual switch of burner motor. b. Burner motor power supply, overload protection, and starter. c. Burner motor. 2. Running or Lockout Interlocks (including Airflow Switch).
6	All	4-10 *	—	Ignition spark (if ignition transformer is connected to Terminal 10)	1. Watch for spark or listen for buzz. a. Ignition electrodes are clean. b. Ignition transformer is okay.
7	All	4-8 *	—	1. Ignition spark (if ignition transformer is connected to Terminal 8). 2. Automatic pilot valve opens (if connected to Terminal 8). NOTE: Refer to wiring diagram of system being tested.	1. Watch for spark or listen for buzz. a. Ignition electrodes are clean. b. Ignition transformer is okay. 2. Listen for click or feel head of valve for activation. a. Actuator if used. b. Pilot valve.
8	All	4-21 *	—	Same as test no. 6 for connections to Terminal 8. If using direct spark ignition, check the first stage fuel valve(s) instead of the pilot valve or MV2 for VP tests.	Same as test no. 6. If using direct spark ignition, check the first stage fuel valve(s) instead of the pilot valve.
9	All	4-9 *	—	Automatic main fuel valve(s) open. If using direct spark ignition on a model with intermittent pilot on Terminal 21, check the optional second stage fuel valve, if used.	1. Listen for and observe operation of the main fuel valve(s) and actuator(s). 2. Valve(s) and actuator(s).
10	All	4-3	—	Alarm (if used) turns on.	1. Alarm.
11	All	4-5 and 12-13	18-L2	Firing rate motor drives open; zero volts at Terminal 18 after motor starts driving open.	1. Low Fire Start Switch. 2. Firing rate motor and transformer.
12	All	4-5 and 14-13	18-L2	Firing rate motor drives closed; line voltage at Terminal 18 after motor is in Low Fire position.	1. Low Fire Start Switch. 2. Firing rate motor and transformer.
13	All	4-5 and 12-13	19-L2	Firing rate motor drives open; line voltage at Terminal 19 after motor is in High Fire position.	1. High Fire Purge Switch. 2. Firing rate motor and transformer.
14	All	4-5 and 14-13	19-L2	Firing rate motor drives closed; zero volts at Terminal 19 after motor starts driving closed.	1. Low Fire Start Switch. 2. Firing rate motor and transformer.
15	All	15-13	—	1. Raise setpoint of Series 90 controller—firing rate motor should drive toward open. 2. Lower setpoint of Series 90 controller—firing rate motor should drive toward closed.	1. Series 90 Controller. 2. Firing rate motor and transformer.
Final	All	 <p>CAUTION Equipment Damage Hazard. Improper wiring can damage equipment. On completing these tests, open the master switch and remove all test jumpers from the subbase terminal. Also remove bypass jumpers from the low fuel pressure limits (if used) to prevent equipment damage.</p>			

* An ammeter can be used to verify the proper connected loads.

OPERATION

Sequence of Operation

The CB780E/CB784E has the following operating sequences, see Fig. 8–10. The CB780E/CB784E LED provide positive visual indication of the program sequence: POWER, PILOT, FLAME, MAIN and ALARM.

Initiate

The CB780E/CB784E enters the INITIATE sequence when the Relay Module is powered. The CB780E/CB784E can also enter the INITIATE sequence if the Relay Module verifies voltage fluctuations of +10/-15 percent or frequency fluctuations of +/-10 percent during any part of the operating sequence. The INITIATE sequence lasts for ten seconds unless the voltage or frequency tolerances are not met. When the tolerances are not met, a hold condition is initiated and displayed on the VFD for at least five seconds. When the tolerances are met, the INITIATE sequence restarts. If the condition is not corrected and the hold condition exists for four minutes, the CB780E/CB784E locks out. Causes for hold conditions in the INITIATE sequence:

- a. AC line dropout is detected.
- b. AC line noise prevents a sufficient reading of the line voltage inputs.
- c. Low line voltage brownouts occur.

The INITIATE sequence also delays the burner motor starter from being energized and de-energized from an intermittent AC line input or control input.

Standby

The CB780E/CB784E is ready to start an operating sequence when the operating control determines a call for heat is present. (Terminal 6, or Terminal 17 if Valve Proving is required.) The burner switch, limits, operating control and all microcomputer monitored circuits must be in the correct state for the CB780E/CB784E to continue into the PREPURGE sequence.

Pre-Purge

Purge timers provide Pre-Purge timings selectable from 30 seconds to 2 1/2 minutes:

- a. The operating control (terminal 6, or terminal 17 for valve proving), Running Interlocks, Pre-Ignition Interlocks, Burner Switch, Run/Test Switch, Lockout Interlocks and all microcomputer monitored circuits must be in the correct operating state.
- b. The blower motor output, terminal 5, is powered to start the PREPURGE sequence. The firing rate motor is driven to the high fire position. The PREPURGE timing does not begin until the Lockout Interlock String and High Fire Switch are both closed.
- c. If Before, Split or Both Valve Proving tests are selected (and demand input T17 is used), the CB780E/CB784E will sequence the main valves to conduct the VP tests concurrently with Pre-Purge (beginning at 10 seconds into the purge time).
- d. The Pre-Ignition Interlock input must remain closed throughout PREPURGE (except during VP testing); otherwise, safety shutdown occurs for the CB780E/CB784E.

- e. The Lockout Interlock inputs (interlock circuit including Airflow Switch) must close by ten seconds after demand; otherwise, a safety shutdown for the CB780E/CB784E occurs.
- f. When PREPURGE timing is complete, the firing rate motor drives to the low fire position.
- g. When the firing rate motor reaches low fire position, the Low Fire Switch, terminal 18, input must be energized before entering the Ignition Trial state.

Ignition Trials—Pilot Lighted System (Except VP System with DSI)

1. Pilot Flame Establishing Period (PFEP):
To get pilot lighted system on VP system, Jumper 2 must be removed. Default is direct spark ignition.
 - a. With the firing rate motor at the low fire position:
 - (1) With the demand on terminal 6, the pilot valve and ignition transformer, terminals 8, 10 and 21, are energized. With the demand on terminal 17 (operating as Valve Proving), the CB780E/CB784E has a 15-second interrupted pilot valve, terminal 21. The CB780E/CB784E have a ten-second interrupted pilot valve/ignition, terminal 8. Terminal 21 is Main Valve 2 only.
 - (2) During PFEP, the Low Fire Switch must remain closed. If it opens, a safety shutdown occurs.
 - (3) The Pre-Ignition Interlock input is ignored throughout the Ignition Trial state.
 - b. Flame must be proven by the end of the ten-second PFEP (four if JR1 is clipped) to allow the sequence to continue. If flame is not proven by the end of PFEP, a safety shutdown occurs.
 - c. After five seconds, the ignition, terminal 10, is de-energized for early spark termination.
2. Main Flame Establishing Period (MFEP):
 - a. Terminal 9 (and 21 in VP mode) is energized when the presence of flame is verified at the end of a 10-second Pilot Flame Establishing Period (PFEP) (four seconds if JR1 is clipped).
 - b. Terminal 8 is turned off 10 seconds after Terminal 9 (and Terminal 21) is energized.
 - c. Terminal 21 action demand on Terminal 6 (without Valve Proving Function) is de-energized 15 seconds after Terminal 9 is energized.

Ignition Trials—Valve Proving with DSI System

1. Demand connected to Terminal 17:
 - JR2 Intact on the CB780E/CB784E
 - a. Ignition, Main Valve 1 and Main Valve 2, Terminals 10, 9, and 21 turn on together.
 - b. Flame must be proven at the end of the 4 second Main Flame Establishing Time.
 - c. Ignition, Terminal 10 is turned off. System now in Run.
 - d. If Flame is not proven, safety lockout occurs.

Run

1. A ten-second stabilization period occurs at the beginning of the RUN period.
2. The firing rate motor releases to modulation.
3. The CB780E/CB784E is now in RUN and remains in RUN until the controller input, terminal 6, opens (terminal 17, on VP applications), indicating that the demand is satisfied or a limit opened.

Postpurge

The CB780E/CB784E provides a programmable (default is 15 seconds) POSTPURGE following the completion of the RUN period. The blower motor output remains powered to drive all products of combustion and any unburned fuel from the combustion chamber. It also supplies combustion air to burn fuel being purged from the fuel line downstream of the fuel shutoff valve.

1. The main fuel valve, Terminals 9 and 21 (if Valve Proving option is used), are de-energized and the firing rate motor is commanded to the low fire position to begin the POSTPURGE period.
2. The Pre-Ignition Interlock closes within the first five seconds after the demand opens.
3. If Valve Proving option—if After, Split, or Both have been selected, then the Valve Proving test will be conducted concurrent with Postpurge. If Postpurge timing remains after the Valve Proving test is completed, the Postpurge timing will complete before going into standby.

Table 9. Sequence Timing for Normal Operation.

Device	Initiate	Standby	Purge	Flame Establishing Period		Run	Post-Purge Timing ^d	Interlock Circuits	Firing Rate Circuit	Approval Code Bodies
				Pilot	Main ^{a, c}					
CB780E/ CB784E	10 sec.	*	**	4 or 10 sec.	10 or 15 sec. ^b	*	15 sec.	Pre-Ignition, Lockout, High and Low Fire	4-wire modulating	UL/CSA/ FM/IRI Modulating

* STANDBY and RUN can be an infinite time period.

** PURGE determined by which purge card is selected.

^a The MFEP is determined by which terminal is used.

^b If DSI is Enabled on a VP application (JR2 intact) then Ignition (terminal 10) and MV₁ (terminal 9), and MV₂ (terminal 21) are energized together. After 4 seconds terminal 10 shuts off, and system goes to Run.

^c If DSI is disabled on a VP application then MFEP is 10 seconds.

^d Default is 15 seconds. Can be programmed as long as 66 minutes.

KEYBOARD DISPLAY MODULE (KDM)

The first line of the Keyboard Display Module provides current status of the burner sequence (STANDBY, PURGE, PILOT IGN, MAIN IGN, RUN and POST-PURGE), timing information (PURGE, PILOT IGN, MAIN IGN and POSTPURGE) in minutes and seconds, hold information (PURGE HOLD: T19) and lockout information (Lockout, Fault Code, Message and Sequence); see Fig. 40. The extreme right side of the first line will either be blank or it will show a small arrow pointing to the second line followed by a two-letter code (DI-Diagnostic Information, Hn-Fault History Information, and EA-Expanded Annunciator). When the arrow and two-letter code are displayed, it indicates the second line is showing a selectable message submenu. The second line will display selectable or preemptive messages. A selectable message supplies information for flame strength, system status indication, system or self-diagnostics and troubleshooting. A preemptive message will have parentheses around the message and supply a detailed message to support the sequence status information. A preemptive message can also be a lockout message. A preemptive message will replace a selectable message to support the sequence status information. It will also replace a selectable message after 60 seconds if it or a lockout message is available. The CB780E/CB784E LEDs provide positive visual indication of the program sequence: POWER, PILOT, FLAME, MAIN and ALARM.

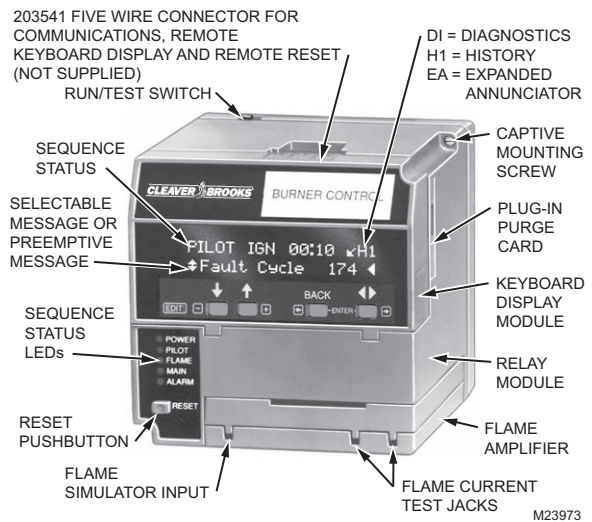

Fig. 40. Keyboard Display Module and sequence status LEDs (Table 4).

NOTE: Normal sequences (in Table 10) are in **BOLD TYPE**, while abnormal sequences are not in bold type.

Table 10. Sequence Status Display Information (see Fig. 40).

Burner Sequence	LEDs Energized (BOLD type)
INITIATE minutes:seconds selectable —message	POWER, PILOT, FLAME, MAIN AND ALARM
INITIATE HOLD: AC (AC Freq/Noise)	POWER, PILOT, FLAME, MAIN AND ALARM

Table 10. Sequence Status Display Information (see Fig. 40). (Continued)

Burner Sequence	LEDs Energized (BOLD type)
INITIATE HOLD: AC (AC Line Dropout)	POWER , PILOT, FLAME, MAIN AND ALARM
INITIATE HOLD: AC (AC Frequency)	POWER , PILOT, FLAME, MAIN AND ALARM
INITIATE HOLD: AC (Low Line Voltage)	POWER , PILOT, FLAME, MAIN AND ALARM
STANDBY selectable—message	POWER , PILOT, FLAME, MAIN AND ALARM
STANDBY HOLD: REM (Remote Control)	POWER , PILOT, FLAME, MAIN AND ALARM
STANDBY HOLD: F/G (Flame Detected)	POWER , PILOT, FLAME , MAIN AND ALARM
STANDBY HOLD: (Preignition ILK)	POWER , PILOT, FLAME, MAIN AND ALARM
STANDBY HOLD: (Lockout ILK)	POWER , PILOT, FLAME, MAIN AND ALARM
PURGE HOLD: (High Fire Switch)	POWER , PILOT, FLAME, MAIN AND ALARM
PURGE DELAY (High Fire Jump)	POWER , PILOT, FLAME, MAIN AND ALARM
PURGE HOLD: TEST (Run/Test Switch)	POWER , PILOT, FLAME, MAIN AND ALARM
PURGE DELAY: (Low Fire Jump)	POWER , PILOT, FLAME, MAIN AND ALARM
PURGE HOLD: F/G (Flame Detected)	POWER , PILOT, FLAME , MAIN AND ALARM
PURGE HOLD: (Low Fire Switch)	POWER , PILOT, FLAME, MAIN AND ALARM
PILOT IGN minutes:seconds selectable—message	POWER , PILOT , FLAME , MAIN AND ALARM
PILOT HOLD: TEST (Run/Test Switch)	POWER , PILOT , FLAME , MAIN AND ALARM
MAIN IGN minutes:seconds selectable—message	POWER , PILOT , FLAME , MAIN AND ALARM
RUN selectable—message	POWER , PILOT , FLAME , MAIN AND ALARM
RUN selectable—message	POWER , PILOT, FLAME , MAIN AND ALARM
RUN LOWFIRE:TEST (Run/Test Switch)	POWER , PILOT, FLAME , MAIN AND ALARM
POSTPURGE minutes:seconds selectable—message	POWER , PILOT, FLAME, MAIN AND ALARM
Waiting for connection...	POWER , PILOT, FLAME, MAIN AND ALARM
RESET/ALARM TEST selectable—message	POWER , PILOT, FLAME, MAIN AND ALARM
Additional sequence status information when an Expanded Annunciator is connected to the relay module, also see CB780E/CB784E System Annunciation Diagnostics and Troubleshooting, Bulletin Number CB-7803.	
BURNER OFF: (Burner Switch)	POWER , PILOT, FLAME, MAIN AND ALARM
STANDBY HOLD: (Expanded Annunciator hold message)	POWER , PILOT, FLAME, MAIN AND ALARM
STANDBY HOLD: (Circuit Fault)	POWER , PILOT, FLAME, MAIN AND ALARM

Keyboard Functions

The keyboard contains four pushbuttons with separate functions (SCROLL-Down, SCROLL-Up, MODE and Change-Level). The MODE and Change-Level push-buttons, when pressed together, provide a SAVE function. When in the Setup Screen—Mode and Change Level serves as Menu or Enter.

1. Down-up arrow push-buttons. See Fig. 41. The down-up arrow push-buttons are used to scroll through the selectable messages. The double-headed arrow, (↕), which is located in the lower left position of the second line of the display, represents the down-up push-buttons. The down-up push-buttons can be pressed to display the selectable messages one at a time or held down to scroll through the selectable messages at the rate of two per second. When the last item of the selectable message is viewed, the display wraps around and displays the first selectable message again.
2. The ◀▶ push-button. See Fig. 42. The ◀▶ push-button is used to change between the first hierarchy of selectable messages to a subset of selectable messages. The ◀▶ push-button can also be used to change from a subset message to a first level selectable message. The symbol located on the second in the lower right corner of the display represents a subset of selectable messages.
3. BACK push-button. See Fig. 43. Use the BACK push-button to instantaneously switch the display from a second-line selectable message to a second-line preempted message. The sixty second time-out function can also be used for this task. The BACK push-button only works if there is a second-line preempted message or a lockout message.

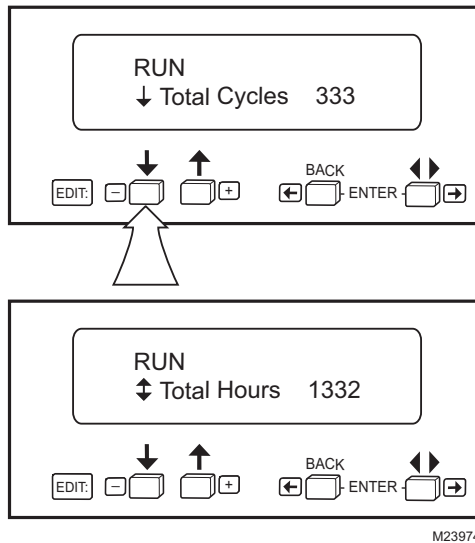

Fig. 41. The ↕ (down-up) push-button function.

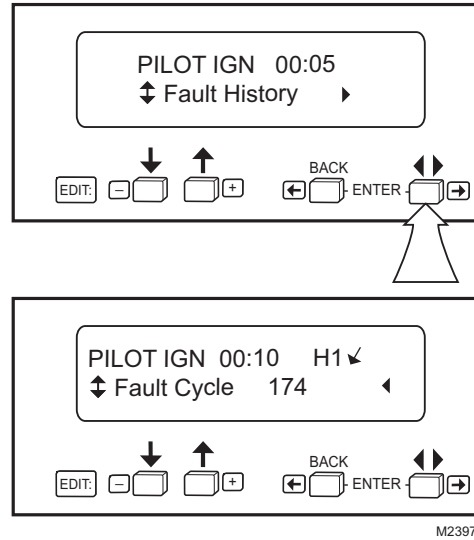

Fig. 42. The ◀▶ (change selectable level) push-button function.

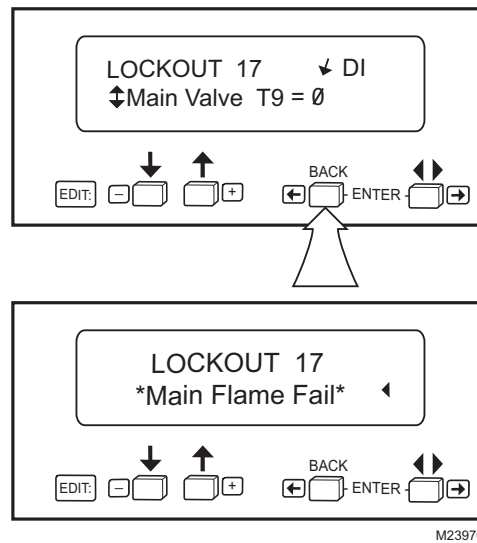

Fig. 43. BACK push-button function.

4. SAVE push-button. See Fig. 44–46.
 - a. This push-button enables users to identify the selectable second line message they want to view upon power restoration (for example, to see “Total Cycles” instead of “Flame Signal”). The second line selectable message is restored to the most recently saved selection when power returns.
 - b. Press the down-up (↕) arrows until the desired second line is displayed. Press the ENTER function.

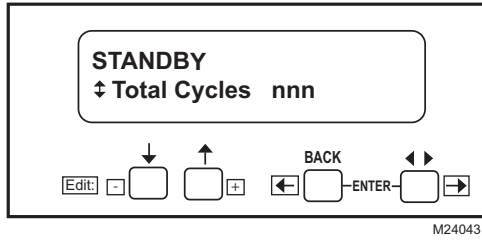

Fig. 44. SAVE Function.

c. The following Display will appear

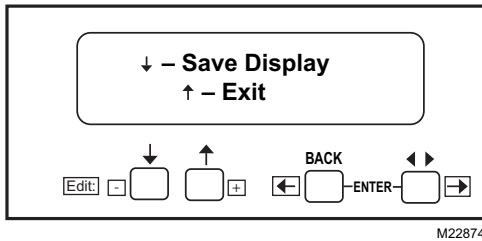

Fig. 45. Save Display/Exit screen.

d. Press the ↓ push-button to save the desired second line. Press the ↑ push-button to exit without changing the second line.

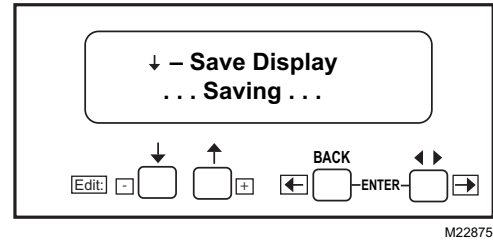

Fig. 46. Save Display...Saving screen.

The second line of the display is now changed to the new selected message.

Table 11. Selectable Messages.

Selectable Message (Second Line)	Display Value (Second Line)	First Line Message
↕Flame Signal	n.nV	
↕Total Cycles	nnnnn	
↕Total hours	nnnnn	
↕Fault History ↔		
↕Fault Cycle	nnnnn <↓H1	
↕Fault Hours	nnnnn <↓H1	
↕Fault Code	nnn <	↓H1
↕*fault—message*		↓H1
↕sequence—message<		↓H1
↕(second-line-msg)<		↓H1
↕Fault Cycle	nnnnn <↓H2	
↕Fault Hours	nnnnn <↓H2	
↕Fault Code	nnn <	↓H2
↕*fault—message*<		↓H2
↕sequence—message<		↓H2
↕(second-line-msg)<		↓H2
↕Fault Cycle	nnnnn <↓H3	
↕Fault Hours	nnnnn <↓H3	
↕Fault Code	nnn <	↓H3
↕*fault—message*<		↓H3
↕sequence—message<		↓H3

Table 11. Selectable Messages. (Continued)

Selectable Message (Second Line)	Display Value (Second Line)	First Line Message
↕(second-line-msg)<		↓H3
↕Fault Cycle	nnnnn <↓H4	
↕Fault Hours	nnnnn <↓H4	
↕Fault Code	nnn <	↓H4
↕*fault—message*<		↓H4
↕sequence—message		↓H4
↕(second-line-msg)		↓H4
↕Fault Cycle	nnnnn <↓H5	
↕Fault Hours	nnnnn <↓H5	
↕Fault Code	nnn <	↓H5
↕*fault—message*<		↓H5
↕sequence—message		↓H5
↕(second-line-msg)		↓H5
↕Fault Cycle	nnnnn <↓H6	
↕Fault Hours	nnnnn <↓H6	
↕Fault Code	nnn <	↓H6
↕*fault—message*<		↓H6
↕sequence—message		↓H6
↕(second-line-msg)		↓H6
↕Diagnostic Info ↔		
↕Device	RM78nnx <	↓DI
↕Device Suffix	nnnn <	↓DI
↕Run/Test Sw.	RUN or TEST <	↓DI
↕Operating Control (OperControl)	1 or 0 <	↓DI
↕Interlock	1 or 0 <	↓DI
↕Pilot Valve	1 or 0 <	↓DI
↕Main Valve	1 or 0 <	↓DI
↕Ignition	1 or 0 <	↓DI
↕Low Fire Sw	1 or 0 <	↓DI
↕High Fire Sw	1 or 0 <	↓DI
↕Preignition Interlock (Prelgn ILK)	1 or 0 <	↓DI
↕Pilot Valve/First State Oil Valve(Valv/ Start, V25)	1 or 0 <	↓DI
↕Jumper 1	INTACT or CLIPPED <	↓DI
↕Jumper 2	INTACT or CLIPPED <	↓DI
↕Jumper 3	INTACT or CLIPPED <	↓DI

Table 11. Selectable Messages. (Continued)

Selectable Message (Second Line)	Display Value (Second Line)	First Line Message
↕Amplifier Type (Amp Type)	NORMAL or AMP-CHECK or SHUTTER	↓DI
↕Flame Response	0.8s or 3s <	↓DI
↕Purge Time	mm:ss <	↓DI
↕Manufacturing Code (Mfg Code)	nnnn <	↓DI
↕Software Revision (SW Rev.)	nnnn/nnnn <	↓DI
↕Expanded Annun. ↔ (see Table 12)		
↕Remote Command	NONE/HOLD/HF/LF	

Expanded Annunciator Messages (See Table 12)

The Expanded Annunciator (EA) might or might not be connected because it is an optional device. If the EA is not connected, a display message of “(EA not connected)” will be

shown. If the EA is connected, display messages will be shown, see Table 12 and CB780E/CB784E System Annunciation Diagnostics and Troubleshooting, Bulletin Number CB-7802, Table 6 and 7, for fault codes. When accessing Expanded Annunciator Messages, follow the same operations as used with the Selectable Messages.

Table 12. Expanded Annunciator Messages.

Selectable Message (Second Line)	Display Value (Second Line)	First Line Message
↕Expanded Annun.↔		
↕Expanded Annunciator (EA not connected)<		
↕Current status (CS:) ^a	EA Message<	
↕Valve Closure (Valve Close)	T4 1 or 0<	↓EA
↕Burner Switch (Burner Sw.)	T5 1 or 0<	↓EA
↕Operating Control (OperControl)	T6 1 or 0<	↓EA
↕Auxiliary Limit (Aux Limit 1)	T7 1 or 0<	↓EA
↕Auxiliary Limit (Aux Limit 2)	T8 1 or 0<	↓EA
↕Low Water Cutoff (LWCO)	T9 1 or 0<	↓EA
↕High Limit (High Limit)	T10 1 or 0<	↓EA
↕Auxiliary Limit (Aux Limit 3)	T11 1 or 0<	↓EA
↕Oil Selection Switch (Oil Select)	T12 1 or 0<	↓EA
↕High Oil Pressure Switch (HiOilPres)	T13 1 or 0<	↓EA
↕Low Oil Pressure Switch (LowOilPres)	T14 1 or 0<	↓EA
↕High Oil Temperature Switch (HiOilTemp)	T15 1 or 0<	↓EA
↕Low Oil Temperature Switch (LowOilTemp)	T16 1 or 0<	↓EA
↕Atomizing Switch (Atomize Sw)	T19 1 or 0<	↓EA
↕Gas Selection Switch (Gas Select)	T17 1 or 0<	↓EA
↕High Gas Pressure Switch (Hi GasPres)	T18 1 or 0<	↓EA
↕Low Gas Pressure Switch (LowGasPres)	T19 1 or 0<	↓EA
↕Airflow Switch (Airflow Sw)	T20 1 or 0<	↓EA

Table 12. Expanded Annunciator Messages. (Continued)

Selectable Message (Second Line)	Display Value (Second Line)	First Line Message
↕Auxiliary Interlock (Aux ILK 4)	T21 1 or 0<	↓EA
↕Auxiliary Interlock (Aux ILK 5)	T22 1 or 0<	↓EA
↕EA Fault Code	nnn<	↓EA
↕Software Revision (SW Rev.)	nnnn<	↓EA

^a Expanded Annunciator Diagnostic Current Status Messages can be reviewed in CB780E/CB784E System Annunciation Diagnostics and Troubleshooting, Bulletin Number CB-7803.

Run/Test Switch Functions

The Run/Test Switch is located on the top side of the CB780E/CB784E; see Fig. 40. The Run/Test Switch allows the burner sequence to be altered as follows:

1. In Prepurge Drive To High Fire Position, the Run/Test Switch, when placed in the TEST position, will hold in PREPURGE with the firing rate motor in the High Fire position.
2. In the measured PREPURGE sequence, the Run/Test Switch, when placed in the TEST position, will cause the PREPURGE timing to stop. The firing rate motor will be in the High Fire position.
3. In Prepurge Drive to Low Fire position, the Run/Test Switch, when placed in the TEST position, will hold the burner sequence in PREPURGE with the firing rate motor in the Low Fire position.
4. In PFEP, the Run/Test Switch, when placed in the TEST position, will stop the timer during the first eight seconds when a ten second PFEP is selected or during the first three seconds when a four second PFEP is selected, allowing pilot-turn-down test and other burner adjustments to be made. This activates a fifteen second flame-out timer that permits pilot flame adjustment without nuisance safety shutdowns. The Run/Test Switch will be ignored during PFEP for the CB780E/CB784E if terminals 8 and 9 or 9 and 21 are jumpered.
5. During RUN, the Run/Test Switch, when placed in the TEST position, will drive the firing rate motor to the Low Fire position.

NOTE: When CB780E/CB784E is switched to the TEST mode, it will stop and hold at the next Run/Test Switch point in the operating sequence. *Make sure that the Run/Test Switch is in the RUN position before leaving the installation.*

CHECKOUT

WARNING

Explosion Hazard.

Can cause severe injury, death or property damage.

Do not allow fuel to accumulate in the combustion chamber. If fuel is allowed to enter the chamber for more than a few seconds without igniting, an explosive mixture could result. It is recommended that you limit the trial for pilot to ten seconds, and limit the attempt to light the main burner to two seconds from the time the fuel has reached the burner nozzle. In any case, do not exceed the nominal lightoff time specified by the equipment manufacturer, close the manual fuel shutoff valve(s), if the flame is not burning at the end of the specified time.

WARNING

Electrical Shock Hazard and Explosion Hazard.

Can cause severe injury, death or property damage.

1. Use extreme care while testing the system. Line voltage is present on most terminal connections when power is on.
2. Open the master switch before removing or installing the CB780E/CB784E or Keyboard Display Module connector.
3. Make sure that all manual fuel shutoff valve(s) are closed before starting the initial lightoff check and the Pilot Turndown tests.
4. Do not place the system in service until you have satisfactorily completed all applicable tests in this section and any others required by the equipment manufacturer.

IMPORTANT:

1. *If the system fails to perform properly, note the fault code, fault message, equipment status, and sequence time on the display. Refer to the Troubleshooting section and the CB780E/CB784E System Annunciation Diagnostics and Troubleshooting Bulletin Number CB-7803.*
2. *Repeat all required Checkout tests after all adjustments are made. All tests must be satisfied with the flame detector(s) in its final position.*

Equipment Recommended

Voltmeter (one megohm/volt minimum sensitivity) with:

- a. 0-300 Vac capability
- b. 0-6000 ohm capability
- c. 0-10 Vdc capability

Checkout Summary

1. Preliminary inspection—all installations.
2. Flame signal measurement—all installations.
3. Initial lightoff check for proved pilot—all installations using a pilot.
4. Initial lightoff check for direct spark ignition of oil—all burners using DSI.
5. Pilot turndown test—all installations using a pilot.
6. Hot refractory hold-in test—all installations using Infrared (lead sulfide) Flame Detectors.
7. Hot refractory hold-in test—all installations.
8. Ignition interference test—all installations using flame rods.
9. Ignition spark pickup—all installations using Ultraviolet Flame Detectors.
10. Response to other ultraviolet sources—all installations using Ultraviolet Flame Detectors.
11. Flame signal with hot combustion chamber—all installations.
12. Safety shutdown tests—all installations.

See Fig. 2 and 3 for the location of component parts, and Fig. 8 and 9 for wiring subbase specifications for terminal locations.

Preliminary Inspection

1. Wiring connections are correct and all terminal screws are tight.
2. Flame detector(s) is clean, and installed and positioned properly. Consult the applicable instructions.
3. Correct combination of amplifier and flame detector(s) is used. See Table 5 in the Specification section.
4. Plug-in amplifier and purge card are securely in place.
5. Burner is completely installed and ready to fire; consult equipment manufacturer instructions. Fuel lines are purged of air.
6. Combustion chamber and flues are clear of fuel and fuel vapor.

7. Power is connected to the system disconnect switch (master switch).
8. Lockout is reset (push in reset button) only if the Relay Module is powered. See Fig. 2 and 3.
9. Run/Test switch is in RUN position.
10. System is in the STANDBY condition. STANDBY message is viewable in the VFD.
11. All limits and interlocks are reset.

Flame Signal Measurement (Table and Fig. 47)

Measure the flame signal at the appropriate times, as defined in the following Checkout tests. Read the flame signal in volts dc at the flame amplifier test jacks “+” and “Com” or at the Keyboard Display Module.

1. Use one megohm/volt meter with a 0 to 10 Vdc capability.
2. Set the one megohm/volt meter to the 0 to 10 Vdc range.
3. Insert the positive (red) probe into the + jack of the flame amplifier. Insert the negative (black) probe into the (Com) jack of the flame amplifier; see Fig. 47.
4. Allow a few seconds for the meter reading to stabilize.
5. If using AMPLI-CHECK™ or shutter check amplifiers, read the average stable voltage, disregarding the peaks and valleys caused by the self-checking operation.
6. The meter reading must be as specified in Table 8 after all tests are completed and all adjustments are made.

As an option, the flame signal can be checked by using the Keyboard Display Module.

If the signal is unstable or less than the minimum acceptable voltage, check flame detector installation and circuitry.

1. Check the supply voltages at terminals 4 (L1) and L2 (N). Make sure the master switch is closed, connections are correct, and the power supply is of the correct voltage, frequency and is sinusoidal.
2. Check the detector wiring for defects including:
 - a. Incorrect connections.
 - b. Wrong type of wire.
 - c. Open circuits.
 - d. Deteriorated wire.
 - e. Short circuits.
 - f. Leakage paths caused by moisture, soot or accumulated dirt.

Table 13. Flame Signal.

Flame Detector	Flame Signal Amplifier	Minimum Acceptable Steady dc Voltage ^a	Maximum Expected dc Voltage
817-1121	833-2741 ^b	1.25 Vdc	5.0 Vdc at Keyboard Display Module or 5.0 Vdc at one megohm/volt meter.
817-1742	833-2722 or 833-2723 ^c		
817-4133	833-3495 or 833-3496 ^c		
817-1743	833-2724		

^a This minimum or stronger signal should easily be obtained if the detector is correctly installed and positioned to properly sense the flame. This voltage must be obtained before completing checkout.

^b The flame detector shutter and amplifier are tested one-half second every five seconds. Series 4 (or greater) amplifiers pulse the shutter when the flame signal reaches 1.5 Vdc. Expected flame signal on Series 4 (or greater) amplifiers will vary between 0.8 Vdc and 2.4 Vdc.

^c This flame amplifier is AMPLI-CHECK™ type. The flame signal amplifier circuitry is tested 1/2 second every five seconds during burner operation and shuts down the burner if the amplifier fails.

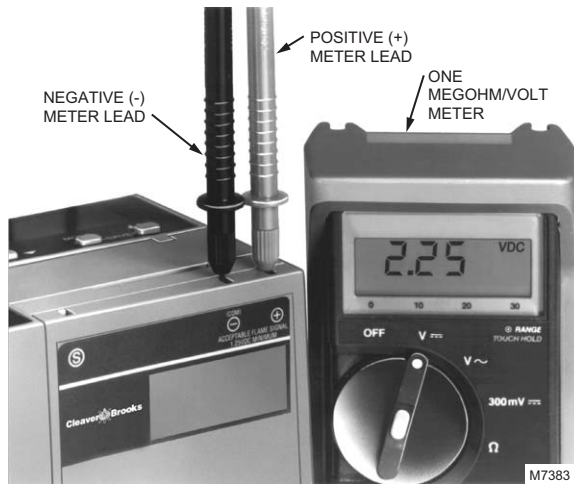

Fig. 47. Flame signal measurement.

3. For all optical detectors, clean the detector viewing window and inside of the sight pipe as applicable.
4. With the burner running, check temperature at the detector. If it exceeds the detector maximum rated temperature:
 - a. Add a heat block to stop conducted heat traveling up the sight pipe.
 - b. Add a shield or screen to reflect radiated heat.
 - c. Add cooling (refer to sight pipe ventilation in the detector Instructions).
5. Make sure the flame adjustment is not too lean.
6. Make sure the detector is properly sighting the flame.
7. If necessary, resight or reposition the detector.

Initial Lightoff Check for Proved Pilot

Perform this check on all installations that use a pilot. It should immediately follow the preliminary inspection.

NOTE: Low fuel pressure limits, if used, could be open. If so, bypass them with jumpers during this check.

1. Open the master switch.
2. Make sure that the manual main fuel shutoff valve(s) is closed. Open the manual pilot shutoff valve. If the pilot takeoff is downstream from the manual main fuel shutoff valve(s), very slightly open the manual main valve to supply pilot gas flow. Make sure the main fuel is shut off just up-stream from the burner inlet, or disconnect power from the automatic main fuel valve(s).
3. Close the master switch and start the system with a *call for heat* by raising the set point of the operating controller; see Fig. 40 for CB780E/CB784E sequence. The program should start the ten second INITIATE sequence.
4. Let the sequence advance through PREPURGE. When the PILOT IGN status is displayed on the Keyboard Display Module, ignition spark should occur and the pilot should light. If the pilot ignites, the FLAME LED will be energized. Proceed to step 7.
5. If the pilot flame is not established in ten seconds, safety shutdown occurs. Let the sequence complete its cycle. Consult the equipment operating manual for further information.

6. Push the reset pushbutton, and let the system recycle once. If the pilot still does not ignite, make the following ignition/pilot adjustments:
 - a. Open master switch and remove the CB780E/CB784E from the subbase.
 - b. On the subbase, temporarily jumper terminal 4 to ignition terminals 8, 10 or 21; refer to the appropriate wiring diagram to determine the proper terminal. Disconnect the leadwire to the pilot valve if it is connected to the same terminal.
 - c. Close the master switch to energize only the ignition transformer.
 - d. If the ignition spark is not strong and continuous, open the master switch and adjust the ignition electrode spark gap setting to the manufacturer recommendations.
 - e. Make sure the ignition electrodes are clean.
 - f. Close the master switch and observe the spark.
 - g. After a continuous spark is obtained, open the master switch and add a jumper on the subbase from terminal 4 (L1) to the pilot terminal 8 or 21. Reconnect the leadwire from the pilot valve if it was disconnected in step b.
 - h. Close the master switch to energize both the ignition transformer and the pilot valve.
 - i. If the pilot does not ignite and if the ignition spark is still continuous, adjust the pressure regulator until a pilot is established.
 - j. When the pilot ignites properly and stays ignited, open the master switch and remove the jumper(s) from terminals 4-8, 4-10 and 4-21 of the subbase.
 - k. Check for adequate bleeding of the fuel line.
 - l. Reinstall the CB780E/CB784E on the subbase, close the master switch, and then return to step 4.
7. When pilot ignites, measure the flame signal. If the pilot flame signal is unsteady or approaching the 1.25 Vdc minimum value, adjust the pilot flame size or detector sighting to provide a maximum and steady flame signal.
8. Recycle the system to recheck lightoff and pilot flame signal.
9. When the MAIN IGN period is displayed on the VFD, make sure the automatic main fuel valve is open; then smoothly open the manual main fuel shutoff valve(s) and watch for main burner flame ignition. When the main burner flame is established, proceed to step 15.
10. If the main burner flame is not established within ten seconds, close the manual main fuel shutoff valve(s).
11. Recycle the system to recheck the lightoff and pilot flame signal.
12. Smoothly open the manual fuel shutoff valve(s) and try lightoff again. (The first reattempt may have been required to purge the lines and bring sufficient fuel to the burner.)
13. If the main burner flame is not established within five seconds or the normal lightoff time specified by the equipment manufacturer, close the manual main fuel shutoff valve(s). Check all burner adjustments.
14. If the main burner flame is not established after two attempts:
 - a. Check for improper pilot size.
 - b. Check for excess combustion air at low fire.
 - c. Check for adequate low fire fuel flow.
 - d. Check for proper gas supply pressure.
 - e. Check for proper valve operation.
 - f. Check for proper pilot flame positioning.
15. Repeat steps 10 through 14 to establish the main burner flame; then proceed to step 16.

16. With the sequence in RUN, make burner adjustments for flame stability and Btu input rating.
17. Shut down the system by opening the burner switch or by lowering the set point of the operating controller. Make sure the main flame goes out. There may be a delay due to gas trapped between the valve(s) and burner. Make sure all automatic fuel valve(s) close.
18. Restart the system by closing the burner switch and/or raising the set point of the operating controller. Observe that the pilot is established during PILOT IGN and the main burner flame is established during MAIN IGN within the normal lightoff time.
19. Measure the flame signal. Continue to check for the proper signal, see Table , through the RUN period. Check the signal at both High and Low Firing Rate positions and while modulating.
20. Run the burner through another sequence, observing the flame signal for:
 - a. Pilot flame alone (DSI).
 - b. Pilot and main flame together.
 - c. Main flame alone (unless monitoring an intermittent pilot). Also observe the time it takes to light the main flame. Ignition of main flame should be smooth.
21. Make sure all readings are in the required ranges before proceeding.
22. Return the system to normal operation.

NOTE: After completing these tests, open the master switch and remove all test jumpers from the subbase terminals, limits/controls or switches.

Initial Lightoff Check for Direct Spark Ignition

This check applies to gas and oil burners not using a pilot. It should immediately follow the preliminary inspection. Refer to the appropriate sample block diagram of field wiring for the ignition transformer and fuel valve(s) hookup.

NOTE: Low fuel pressure limits, if used, could be open. If so, bypass them with jumpers during this check.

1. Open the master switch.
2. Complete the normal *ready-to-fire* checkout of the fuel supply and equipment as recommended by the equipment manufacturer.
3. Close all manual main fuel shutoff valve(s). Check that the automatic fuel valve(s) are closed. Make sure fuel is not entering the combustion chamber.
4. Close the master switch and start the system with a *call for heat* by raising the setpoint of the operating controller, see Fig. 8 and 9 for CB780E/CB784E sequence. The program sequence should start the ten second INITIATE sequence.
5. Let the sequence advance through PREPURGE. Ignition spark should occur after PREPURGE period. Listen for the click of the first stage fuel solenoid valve(s).
6. Let the program sequence complete its cycle.
7. Open the manual fuel shutoff valve(s).
8. Push the reset button and recycle the program sequence through PREPURGE.
9. When PILOT IGN status is displayed, watch that the first stage burner flame is established. If it is established, proceed to step 15.
10. If the first stage burner flame is not established within ten seconds, close the manual fuel shutoff valve(s), and open the master switch after POSTPURGE is completed.
11. Check all burner adjustments.
12. Wait about three minutes. Close the master switch, open the manual fuel shutoff valve(s), and try to lightoff the burner again. The first attempt may have been required to purge the lines and bring sufficient fuel to the burner.
13. If the first stage burner flame is not established within ten seconds, close the manual fuel shutoff valve(s), and open the master switch.
14. If necessary, repeat steps 11 through 13 to establish the first stage burner flame. Then proceed to step 15.
15. When the first stage burner flame is established, the sequence will advance to RUN. Make burner adjustments for flame stability and input rating. If a second stage is used, proceed to step 18.
16. Shut down the system by opening the burner switch or by lowering the set point of the operating controller. Make sure the burner flame goes out and all automatic fuel valve(s) close.
17. If used, remove the bypass jumpers from the low fuel pressure limit and subbase.
18. If a second stage is used, make sure the automatic second stage fuel valve(s) has opened. Check the lightoff as follows (otherwise proceed to step 19):
 - a. Open the manual second stage fuel valve(s).
 - b. Restart the system by raising the set point of the operating controller.
 - c. When the first stage burner flame is established, watch for the automatic second stage fuel valve(s) to open. Observe that the second stage lights off properly.
 - d. Make burner adjustments for flame stability and input rating.
 - e. Shut down the system by lowering the set point of the operating controller. Make sure the burner flame goes out and all automatic fuel valve(s) close.
 - f. Proceed to step 19.
19. Restart the system by closing the burner switch and/or raising the set point of the operating controller. Observe that the burner flame is established during PILOT IGN, within the normal lightoff time specified by the equipment manufacturer.
20. Measure the flame signal. Continue to check for the proper signal, see Table , through the RUN period. Check the signal at both high and low firing rate positions and while modulating. Any pulsating or unsteady readings will require further attention.
21. Make sure all readings are in the required ranges before proceeding.

NOTE: Upon completing these tests, open the master switch and remove all test jumpers from the subbase terminals, limits/controls or switches.

22. Return the system to normal operation.

Pilot Turndown Test (All Installations Using a Pilot)

Perform this check on all installations that use a pilot. The purpose of this test is to verify that the main burner can be lit by the smallest pilot flame that will hold in the flame amplifier and energize the FLAME LED. Clean the flame detector(s) to make sure that it will detect the smallest acceptable pilot flame. If using AMPLI-CHECK™ or Self-Checking Amplifier and 1M ohm/volt meter, the flame signal will fluctuate every time the amplifier does a self-check or a shutter check.

NOTE: Low fuel pressure limits, if used, could be open. If so, bypass them with jumpers during this test.

1. Open the master switch.
2. Close the manual main fuel shutoff valve(s).
3. Connect a manometer (or pressure gauge) to measure pilot gas pressure during the turndown test.
4. Open the manual pilot shutoff valve(s).
5. Close the master switch and start the system with a *call for heat*. Raise the set point of the operating controller. The program sequence should start, and PREPURGE should begin.
6. When the PILOT IGN begins, set the Run/Test Switch to TEST position to stop the sequence. The FLAME LED will come on when the pilot ignites.

NOTE: If the sequence does not stop, reset the system and make sure you set the Run/Test Switch to TEST within the first eight seconds of the PILOT IGN sequence.

IMPORTANT:

You have eight seconds or three seconds, depending on PFEP selected, to position the Run/Test Switch to the TEST position to stop the sequence after the start of the PILOT IGN period.

7. Turn the pilot pressure down very slowly, reading the manometer (or pressure gauge) as it drops. Stop instantly when the FLAME LED goes out. Note the pressure at the CB780E/CB784E flame relay dropout point. The pilot is at the minimum turndown position. Immediately turn up the pilot pressure until the FLAME LED comes on again or the flame signal increases to 1.25 Vdc.

NOTE: If there is no flame for fifteen seconds with the sequence stopped at this point, the CB780E/CB784E will lockout and flash a lockout message; see Fig. 48.

8. Repeat step 7 to verify the pilot gas pressure reading at the exact point the FLAME LED light goes out.
9. Increase the pilot pressure immediately until the FLAME LED comes on, and then turn it down slowly to obtain a pressure reading just above the dropout point or until the flame signal increases to 1.25 Vdc.
10. Set the Run/Test Switch in the RUN position and let the sequence proceed. At ten seconds into the Ignition Trial period, make sure the automatic main fuel valve(s) open; then smoothly open the manual main fuel shutoff valve(s) (or any other manually opened safety shutoff valve(s), if used) and watch for main burner ignition. If the main burner flame is established, proceed to step 18.

NOTE: This step requires two people, one to open the manual valve(s) and one to watch for ignition.

11. If the main burner flame is not established within ten seconds, close the manual main fuel shutoff valve(s) and open the master switch. If the lightoff was rough, the pilot flame size is too small.
12. Recycle the burner and stop the sequence in the PILOT IGN period by using the Run/Test Switch.
13. Increase the pilot flame size by increasing its fuel flow until a smooth main flame is accomplished.
14. Reposition the flame scanner sight tube or use orifices until the pilot flame signal voltage is in the range of 1.25 to 1.50 Vdc.

15. When the main burner lights reliably with the pilot at turndown, disconnect the manometer (or pressure gauge) and turn the pilot gas flow up to that recommended by the equipment manufacturer.
16. **If used, remove the bypass jumpers from the sub-base terminals, limits/controls, or switches.**
17. Run the system through another cycle to check for normal operation.
18. Return the system to normal operation.

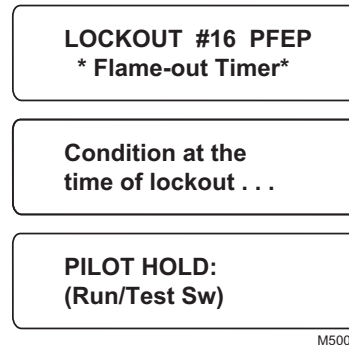

Fig. 48. Flame-out timer lockout.

Hot Refractory Saturation Test (All Infrared Detectors)

Test to make certain that radiation from hot refractory does not mask the flickering radiation of the flame itself.

Start the burner and monitor the flame signal during the warm-up period. A decrease in signal strength as the refractory heats up indicates hot refractory saturation. If saturation is extreme, the flame signal will drop below 1.25 Vdc and the system will shut down as though a flame failure occurred.

If hot refractory saturation occurs, the condition must be corrected. Add an orifice plate in front of the cell to restrict the viewing area, lengthen the sight pipe or decrease the pipe size (diameter). Continue adjustments until hot refractory saturation is eliminated.

Hot Refractory Hold-in Test (All Infrared Detectors)

Test to make certain hot refractory will not delay the flame detection system response to a flameout. This condition can delay response to flame failure and also can prevent a system restart as long as hot refractory is detected.

Infrared (lead sulfide) detectors can respond to infrared rays emitted by a hot refractory, even when the refractory has visibly ceased to glow. Infrared radiation from a hot refractory is steady, but radiation from a flame has a flickering characteristic. The infrared detection system responds only to flickering infrared radiation; it can reject a steady signal from hot refractory. The refractory steady signal can be made to fluctuate if it is reflected, bent or blocked by smoke or fuel mist within the combustion chamber. Be careful when applying an infrared system to verify its response to flame only.

To check infrared (lead sulfide) detectors for hot refractory hold-in, operate the burner until the refractory reaches its maximum temperature. If the installation has a multi-fuel burner, burn the heavier fuel that is most likely to reflect, bend

or obscure the hot refractory steady infrared radiation. When the maximum refractory temperature is reached, close all manual fuel shutoff valve(s), or open the electrical circuits of all automatic fuel valve(s). Visually observe when the burner flame or FLAME LED goes out. If this takes more than three seconds, the infrared detector is sensing hot refractory. Immediately terminate the firing cycle. (Lower the set point to the operating controller, or set the Burner Switch to OFF. Do not open the master switch.)

NOTE: Some burners continue to purge oil lines between the valve(s) and nozzle(s) even though the fuel valve(s) are closed. Terminating the firing cycle (instead of opening the master switch) will allow purging the combustion chamber. This will reduce a buildup of fuel vapors in the combustion chamber caused by oil line purging.

If the detector is sensing hot refractory, the condition must be corrected. Add an orifice plate in front of the cell to restrict the viewing area of the detector. If this does not correct the problem, resight the detector at a cooler, more distant part of the combustion chamber. While resighting the detector, be aware that it must also properly sight the flame. For an infrared detector, try lengthening the sight pipe or decreasing the pipe size (diameter). For details, refer to the detector Instructions and the equipment Operating Manual. Continue adjustments until hot refractory hold-in is eliminated.

Ultraviolet Sensor, Ignition Spark Response Test (All Ultraviolet Detectors)

Test to make certain that the ignition spark is not actuating the FLAME LED.

1. Close the pilot and main burner manual fuel shut-off valve(s).
2. Start the burner and use the Run/Test Switch to stop the sequence in the PILOT IGN period. Ignition spark should occur, but the flame signal should not be more than 0.5 Vdc.
3. If the flame signal is higher than 0.5 Vdc and the FLAME LED does come on, consult the equipment operating manual and resight the detector farther out from the spark, or away from possible reflection. It may be necessary to construct a barrier to block the ignition spark from the detector view. Continue adjustments until the flame signal due to ignition spark is less than 0.5 Vdc.

Response to Other Ultraviolet Sources

Some sources of artificial light, such as incandescent or fluorescent bulbs, mercury sodium vapor lamps and daylight, produce small amounts of ultraviolet radiation. Under certain conditions, an ultraviolet detector will respond to these sources as if it is sensing a flame. To check for proper detector operation, check the Flame Failure Response Time (FFRT) and conduct Safety Shutdown Tests under all operating conditions.

Flame Signal With Hot Combustion Chamber (All Installations)

With all initial start-up tests and burner adjustments completed, operate the burner until the combustion chamber is at the maximum expected temperature. Observe the equipment manufacturer warm-up instructions. Recycle the burner under

these hot conditions and measure the flame signal. Check the pilot alone, the main burner flame alone, and both together (unless monitoring only the main burner flame when using DSI). Check the signal at both High and Low Firing Rate positions and while modulating, if applicable.

If the flame signal is too low or unsteady, check the flame detector temperature. Relocate the detector if the temperature is too high. If necessary, realign the sighting to obtain the proper signal and response time. If the response time is still too slow, replace the Plug-in Flame Signal Amplifier. If the detector is relocated or resighted, or the amplifier is replaced, repeat all required Checkout tests. Check the FFRT of the Flame Amplifier. Lower the set point of the operating controller and observe the time it takes for the burner flame to go out. This should be within 3 seconds maximum.

Safety Shutdown Tests (All Installations)

Perform these tests at the end of Checkout, after all other tests have been completed. If used, the external alarm should turn on. Press the CB780E/CB784E reset pushbutton to restart the system.

1. Opening a Preignition Interlock during STANDBY or PREPURGE period.
 - a. *Preignition ILK* fault will be displayed on the VFD. Fault code 10 or 33 will be displayed to denote the fault.
 - b. Safety shutdown will occur.
2. Opening a Lockout Interlock during PREPURGE, PILOT IGN, MAIN IGN or RUN period.
 - a. *Lockout ILK* fault will be displayed on the VFD. Fault code 11 or 12 or 21 or 29 will be displayed to denote the fault.
 - b. Safety shutdown will occur.
3. Detection of flame 40 seconds after entry to STAND-BY, fault code 9. Detection of flame ten seconds into Drive to Purge Rate or during measured PREPURGE time.
 - a. Simulate a flame to cause the flame signal voltage level to be at least 1.25 Vdc for 40 seconds after entry to STANDBY and also simulate a flame signal for 10 seconds during PREPURGE.
 - b. *Flame Detected* fault will be displayed on the VFD. Fault code 9 or 15 or 18 will be displayed to denote the fault.
 - c. Safety shutdown will occur.
4. Failure to ignite pilot.
 - a. Close pilot and main fuel manual shutoff valve(s).
 - b. Depress the reset button.
 - c. Start the system.
 - d. The automatic pilot valve(s) should be energized but the pilot cannot ignite.
 - e. *Pilot Flame Fail* fault will be displayed on the VFD. Fault code 28 will be displayed four or ten seconds (depending on the jumper configuration selection for PFEP) after the pilot valve(s) is energized to denote the fault.
 - f. Safety shutdown will occur.
5. Failure to ignite main.
 - a. Open the manual pilot valve(s); leave the main fuel manual shutoff valve(s) closed.
 - b. Depress the reset button.
 - c. Start the system.
 - d. The pilot should ignite and the flame signal should be at least 1.25 Vdc but the main burner cannot light.
 - e. The flame signal should drop below 1.25 Vdc within 3 seconds after the interrupted pilot goes out.

- f. *Main Flame Ign.* fault will be displayed on the VFD. Fault code 19 will be displayed to denote the fault.
- g. Safety shutdown will occur.
- 6. Loss of flame during RUN.
 - a. Open the main fuel manual shutoff valve(s) and open manual pilot shutoff valve(s).
 - b. Depress the reset button.
 - c. Start the system. Start-up should be normal and the main burner should light normally.
 - d. After the sequence is in the normal RUN period for at least ten seconds with the main burner firing, close the manual main fuel shutoff valve(s) to extinguish the main burner flame.
 - e. The flame signal should drop below 1.25 Vdc within 3 seconds after the main flame goes out.
 - f. *Main Flame Fail* fault will be displayed on the KDM. Fault code 17 will be displayed to denote the fault.
 - g. Safety shutdown will occur.
- 7. Opening a Preignition Interlock after the first five seconds of POSTPURGE.
 - a. *Preignition ILK* fault will be displayed on the KDM. Fault code 33 will be displayed to denote the fault.
 - b. Safety shutdown will occur.

IMPORTANT:

1. If the CB780E/CB784E fails to shut down on any of these tests, take corrective action; refer to CB780E/CB784E Troubleshooting and diagnostics manual and return to the beginning of all Checkout tests.
2. When all Checkout tests have been completed, reset all switches to original status.

TROUBLESHOOTING

Troubleshooting can be accomplished by using the 833-2727 Keyboard Display Module (KDM) or a blinking POWER LED.

The Power LED provides fault identification when the relay moduel locks out an alarm. Fault identification is a series of fast and slow blinking LED lights. The fast blinks idenyify the “tens” portion of the fault code (for example, three fast blinks = 30). The slow blinks identify the “units” portion of the fault code (for example, 2 slow blinks = 2). Three fast blinks followed by two slow blinks = fault code 32. (See Table 14 for the blinking fault code list).

The LED code repeats as long as the fault exists. To clear the fault, press the RESET button.

Use Table 14 to identify fault code numbers, possible system failure, and recommended troubleshooting procedures.

Table 14. Blinking Fault Codes and Recommended Troubleshooting.

Blink Code	System Failure	Recommended Troubleshooting
Code 1-1 *Low AC Line Voltage*	Low AC Line detected.	<ol style="list-style-type: none"> 1. Check the relay module and display module connections. 2. Reset and sequence the Relay Module. 3. Check the system power supply and make sure that frequency and voltage meet specifications. 4. Check the backup power supply, as appropriate.
Code 1-2 *AC Quality Problem*	Excessive noise or device running on slow, fast, or AC line dropout detected.	
Code 2-1 *Unexpected Flame Signal*	Flame sensed when no flame is expected during STANDBY or PURGE.	<ol style="list-style-type: none"> 1. Check that flame is not present in the combustion chamber; correct any errors. 2. Make sure that the flame amplifier and flame detector are compatible. 3. Check the wiring and correct any errors. 4. Remove the flame amplifier and inspect its connections. Reseat the amplifier. 5. Reset and sequence the relay module. 6. If the code reappears, replace the flame amplifier and/or the flame detector. 7. If the fault persists, replace the relay module.
Code 2-2 *Flame Signal Absent*	No-flame time present at the end of the Pilot Flame Establishing Period; lost during the Main Flame Establishing Period or during RUN.	<ol style="list-style-type: none"> 1. Measure the flame signal. If one exists, verify that it meets specifications. 2. Make sure that the flame amplifier and flame detector are compatible. 3. Inspect the main fuel valve(s) and valve connection(s). 4. Verify that the fuel pressure is sufficient to supply fuel to the combustion chamber. Inspect the connections to the fuel pressure switches. Make sure they are functioning properly. 5. Inspect the Airflow Switch and make sure that it is functioning properly. 6. Check the flame detector sighting position; reset and recycle. Measure the flame signal strength. Verify that it meets specifications. If not, refer to the flame detector and/or flame amplifier checkout procedures in the installation instructions. 7. Replace the flame amplifier and/or the flame detector, if necessary. 8. If the fault persists, replace the relay module.

Table 14. Blinking Fault Codes and Recommended Troubleshooting. (Continued)

Blink Code	System Failure	Recommended Troubleshooting
Code 2-3 *Flame Signal Overrange*	Flame signal value is too high to be valid.	<ol style="list-style-type: none"> 1. Make sure the flame detector and flame amplifier are compatible. 2. Remove the flame amplifier and inspect its connections. Reset the flame amplifier. 3. Reset and sequence the relay module. 4. Check the flame detector sighting position; reset and recycle. Measure flame strength. Verify that it meets specifications. If not, refer to the flame detector and/or flame amplifier checkout procedures in the installation instructions. 5. If the code reappears, replace the flame amplifier and/or the flame detector. 6. If the fault persists, replace the relay module.
Code 3-1 *Running/ Interlock Switch Problem*	Running or Lockout Interlock fault during Pre-Purge.	<ol style="list-style-type: none"> 1. Check wiring; correct any errors. 2. Inspect the fan; make sure there is no air intake blockage and that it is supplying air. 3. Make sure the Lockout Interlock switches are functioning properly and the contacts are free from contaminants. 4. Reset and sequence the relay module to Pre-Purge (place the TEST/RUN Switch in the TEST position, if available). Measure the voltage between terminal 7 and G (ground); line voltage should be present. Switch TEST/RUN back to RUN. 5. If steps 1 through 4 are correct and the fault persists, replace the relay module.
Code 3-2 *Running/ Interlock On During Standby*	Lockout Interlock powered at improper point in sequence or On in Standby.	<ol style="list-style-type: none"> 1. Check wiring to make sure that the Lockout Interlocks are connected properly between terminals 6 and 7. Correct any errors. 2. Reset and sequence the relay module. 3. If the fault persists, measure the voltage between terminal 6 and G (ground), then between terminal 7 and G. If there is line voltage at terminal 6 when the controller is off, the controller switch may be bad or is jumpered. 4. If steps 1 through 3 are correct and there is line voltage at terminal 7 when the controller is closed and the fault persists, check for a welded or jumpered Running Interlock or Airflow Switch. Correct any errors. 5. If steps 1 through 4 are correct and the fault persists, replace the relay module.
Code 3-3 *VPS in Improper State*	VPS (Valve Proving Switch) in wrong state during VPS Test.	<ol style="list-style-type: none"> 1. Check wiring, making sure upstream valve is connected to terminal 9 and downstream valve is connected to terminal 17. 2. Conduct Valve Seat leakage test using a manometer. 3. Reset and sequence the relay module; if fault repeats, test VPS (connected to terminal 16) is functioning properly; replace if necessary. 4. Reset and sequence the relay module. 5. If fault persists, replace the relay module.
Code 4-1 *Purge Card Problem*	No purge card or the purge card timing has changed from the original configuration.	<ol style="list-style-type: none"> 1. Make sure the purge card is seated properly. 2. Inspect the purge card and the connector on the relay module for any damage or contaminants. 3. Reset and sequence the relay module. 4. If the fault code reappears, replace the purge card. 5. Reset and sequence the relay module. 6. If the fault code persists, replace the relay module.
Code 4-2 *Wiring Problem/ Internal Fault*	Pilot (ignition) valve terminal, main valve, ignition or Main Valve 2 was on when it should be off.	<p>⚠ WARNING Electrical Shock Hazard; Fire or Explosion Hazard. Can cause severe injury, death or property damage. Remove system power and turn off power supply.</p> <ol style="list-style-type: none"> 1. Remove system power and turn off fuel supply. 2. Check wiring; correct any errors. 3. Inspect Pilot Fuel Valve(s), both places, and connections. 4. Reset and sequence the relay module. 5. If the fault persists, replace the relay module.
Code 4-3 *Flame Amplifier Problem*	Flame not sensed, or sensed when it should be on or off.	<ol style="list-style-type: none"> 1. Check wiring; correct any errors. 2. Make sure the flame amplifier and flame detector are compatible. 3. Remove the flame amplifier and inspect the connections. Reseat the amplifier. 4. Reset and sequence the relay module. 5. If the code reappears, replace the flame amplifier and/or the flame detector. 6. If the fault persists, replace the relay module.

Table 14. Blinking Fault Codes and Recommended Troubleshooting. (Continued)

Blink Code	System Failure	Recommended Troubleshooting
Code 4-4 *Configuration Jumper Problem*	The configuration jumpers differ from the sample taken at startup.	<ol style="list-style-type: none"> 1. Inspect the jumper connections. Make sure the clipped jumpers were completely removed. 2. Reset and sequence the relay module. 3. If the fault persists, replace the relay module.
Code 5-1 *Pre-Ignition Interlock*	Pre-Ignition Interlock fault.	<ol style="list-style-type: none"> 1. Check wiring and correct any errors. 2. Check Pre-Ignition Interlock switches to assure proper functioning. 3. Check fuel valve operation. 4. Reset and sequence the relay module; monitor the Pre-Ignition Interlock status. 5. If the fault persists, replace the relay module.
Code 5-2 *High Fire Sw. or Low Fire Sw.*	Either High Fire Switch or Low Fire Switch failure.	<ol style="list-style-type: none"> 1. Check wiring and correct any errors. 2. Reset and sequence the relay module. 3. Use manual motor potentiometer to drive the motor open and closed. Verify at motor switch that the end switches are operating properly. Use RUN/TEST switch if manual potentiometer is not available. 4. Reset and sequence the relay module. 5. If the fault persists, replace the relay module.
Code 5-3 *Man-Open Sw.; Start Sw. or Control On*	Man-Open Switch, Start Switch or Control On in the wrong operational state.	<ol style="list-style-type: none"> 1. Check wiring and correct any errors. 2. Make sure that the Manual Open Valve Switch, Start Switch and Control are operating properly. 3. Stat Switch held "On" too long. 4. Reset and sequence the relay module. 5. Reset and sequence the relay module. If the fault persists, replace the relay module (CB780E or CB784E).
Code 6-1 *Internal Faults*	Relay Module self-test failure.	<ol style="list-style-type: none"> 1. Reset and sequence the relay module. 2. If fault reappears, remove power from the device, reapply power, then reset and sequence the relay module. 3. If the fault persists, replace the relay module.
Code 6-2 *Internal Faults*	Relay Module Self-Test failure.	<ol style="list-style-type: none"> 1. Reset and sequence the relay module. 2. If fault reappears, remove power from the device, reapply power, then reset and sequence the relay module. 3. If fault does not repeat on the next cycle, check for electrical noise being copied into the relay module through the external loads or possibly an electrical grounding issue. 4. If the fault persists, replace the relay module.
Code 6-3 *Device Specific*	Fault with special OEM input circuits.	<ol style="list-style-type: none"> 1. Check wiring and operation of special OEM inputs. 2. Reset and sequence the relay module. 3. If fault reappears, remove power from the device, reapply power, then reset and sequence the relay module. 4. If the fault does not repeat on the next cycle, check for electrical noise being copied into the relay module through the external loads or possibly an electrical grounding issue. 5. If the fault persists, replace the relay module.
Code 6-4 *Accessory Fault*	VPS setup.	<ol style="list-style-type: none"> 1. Make sure Relay Module VP is programmed. 2. T6 and T17 powered at the same time—correct wiring. 3. Reset control if fault persists. Replace relay module.
Code 7-7 *Unused*	Unused at this time.	—

CB780/ECB784E System Diagnostics

Troubleshooting control system equipment failures is made easier with the CB780E/CB784E self-diagnostics and first-out annunciation. In addition to an isolated spst alarm relay (audible annunciation), the CB780E/CB784E provides visual annunciation by displaying a fault code and fault or hold message at the Keyboard Display Module. The CB780E/CB784E provides 118 diagnostic messages for troubleshooting the system (see the CB780E/CB784E System Annunciation Diagnostics and Troubleshooting, Bulletin Number CB-7803.

Self-diagnostics of the CB780E/CB784E enables it to detect and annunciate both external and internal system problems. Internal faults and external faults such as interlock failures, flame failures and false flame signals are annunciated by the CB780E/CB784E, which energizes the ALARM LED or visually displayed at the Keyboard Display Module.

The KDM displays a sequence status message indicating: STANDBY, PREPURGE, PILOT IGN, MAIN IGN, RUN and POSTPURGE. The selectable messages also provide visual indication of current status and historical status of the equipment such as: Flame Signal, Total Cycles, Total Hours, Fault History, Diagnostic Information and Expanded

Annunciator terminal status (if used). With this information, most problems can be diagnosed without extensive trial and error testing.

Table 10 provides the sequence and status hold messages. Table 14 provides a summary of all CB780E/CB784E fault messages and fault codes. In addition, Diagnostic Information and History Data are available to assist in troubleshooting the CB780E/CB784E, see Table 12.

The CB780E/CB784E provides diagnostic information to aid the service mechanic in obtaining information when troubleshooting the system; see Table 10, 11, 12, and 14. Information available in the Diagnostic Information includes Device Type, Device Suffix, Software Revision, Manufacturing Code, Flame Amplifier Type, Flame Failure Response Time, Selectable Jumper Configuration Status, Run/Test Switch Status and Terminal Status.

Diagnostic Information Index

The CB780E/CB784E monitors input/output terminals and can display the status of the terminal at the KDM (example: Pilot Valve T8 ON<). See Table 11 for a complete terminal description and number. The display will show the actual status of the terminal. If voltage is detected at the terminal, ON is displayed, but if no voltage is detected at the terminal, OFF is displayed; see Table 11.

APPENDIX A

Valve Proving Test

The Valve Proving System feature offers a systematic way of testing the valve seat integrity to assure the valves are indeed in the closed position when the system is off-line, in STANDBY.

WARNING

Explosion Hazard.

Can cause severe injury, death or property damage.

Leaking gas valves can result in fire or explosion. The Valve Proving System is designed to detect such leaks. A valve proving test time that is too short may allow unacceptable leaks to go undetected. Use the procedure in Appendix A to select sufficient valve test times to detect any unacceptable leak.

The following steps are to determine the test time for the relay module to verify the valve seats are not leaking at a rate of greater than/equal to 0.1% of the burner capacity.

Fig. 49 shows a typical valve train. The legend identifies information that will be used to fill out the worksheet that appears at the end of this appendix.

1. Identify items of your system and fill in the "Information" portion of the worksheet.
2. Go to the Lookup Tables noted (17, 18 or 19) to get the results for your system.

Historical Information Index

The CB780E/CB784E has nonvolatile memory that allows the Relay Module to retain Historical Information for the six most recent lockouts. Each of the six lockout files retains the cycle when the fault occurred, the hour of operation when the fault occurred, a fault code, a fault message and burner status when the fault occurred; see Table 10.

SERVICE NOTE:

Reset CB780E/CB784E by pressing the reset pushbutton on the CB780E/CB784E, or pressing a remote reset pushbutton wired through the the 5-wire connector (833-2760, ordered separately) on the Keyboard Display Module or DATA CONTROLBUS MODULE™. A power-up reset will cause an electrical reset of the CB780E/CB784E but will not reset a lockout condition.

SERVICE NOTE:

If the Keyboard Display Module is *scrambled*, remove and reinstall the Keyboard Display Module, and reset the CB780E/CB784E Relay Module.

SERVICE NOTE:

Use the access slots on the sides of the Wiring Subbase to check the terminal voltage of the CB780E/CB784E.

SERVICE NOTE:

Maximum ambient operating temperature of an 817-1121 flame sensor, Series 1 through 6 will be reduced to 125°F because of the duty cycle operation of the CB780E/CB784E Relay Module.

IMPORTANT

The Tables show information on Honeywell Valves only. Contact other valve manufacturers to obtain data on their specific valves.

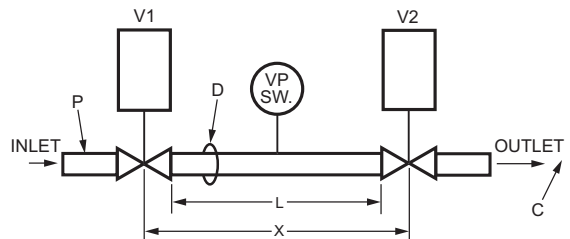

LEGEND

- V1 UPSTREAM VALVE
- V2 DOWNSTREAM VALVE
- D PIPE DIAMETER (IN INCHES.) USED TO DETERMINE A; ARE FOUND IN TABLE III
- L PIPE LENGTH (IN FEET)
- P VALVE INLET PRESSURE (PSIG)
- C BURNER MAX. FIRING (CFH)
- X CALCULATED TEST VALVE TRAIN VOLUME

M22778

Fig. 49. Typical valve train layout.

3. Use appropriate Results column items to fill in the Valve Train Volume Formula and the Calculation of Valve Proving Test Time.
4. Round up the time to the nearest second.
5. The test time calculated is the time you will enter into the VPS Setup.

Calculation of Valve Train Volume

$$X = V_1 + V_2 + (A \times L/144)$$

Calculation of Valve Proving Test Time

$$\text{Test Time} = 187,000 \times (P \times X)/C$$

Table 15. Valve Proving Test Time Symbols and Descriptions.

Symbol	Unit	Description
X	ft ³	Volume between the two valves to be tested.
V ₁	ft ³	Volume of upstream valve outlet cavity.
V ₂	ft ³	Volume of downstream valve inlet cavity.
L	ft	Length of pipe between valves.
D	npt	Pipe Size—used to define A
A	in. ²	Pipe Cross Section Area (from Table 15)
Test Time	Seconds	Minimum VPS test period.
P	psi	Gas inlet pressure to upstream valve.
C	ft ³ /hr	Burner Capacity.

NOTE: V₁ is the outlet cavity of the upstream valve and V₂ is the inlet cavity of the downstream valve.

NOTE: 10 seconds is the minimum test time allowed. If your calculations are less than 10 seconds, enter 10 seconds.

For Example:

We have a 2.5 MBTU burner with 2 psi valve train inlet pressure. The upstream valve is a proof-of-closure 940-04544 with an On/Off 940-04539 valve downstream. We have a 2 in. NPT pipe, 1-3/4 ft long, between the valves.

Table 16. VPS Worksheet Example.

Item	Description	Information	Lookup Table	Results	Formula Item
V ₁	Upstream Valve Volume	940-04544	17	0.0218	V ₁
V ₂	Downstream Valve Volume	940-04539	18	0.0238	V ₂
D	Pipe Size NPT (in.)	2 in. NPT	19	3.356	A
L	Pipe Length (ft)	1.75 ft	—	1.75	L
P	Valve Inlet Pressure (psig) ^a	2	—	2	P
C	Burner Maximum Firing (cf/hr) ^b	2.5 mbtu	—	2500	C

^a Divide inches w.c. by 27.7 to get psi.

^b Divide Btuh by 1000 to get cf/hr for natural gas or by 2550 to get cf/hr for LP gas.

Calculation of Valve Train Volume:

$$X = V_1 + V_2 + (A \times L \div 144)$$

$$X = 0.0218 + 0.0238 + (3.356 \times 1.75 \div 144) = 0.0864.$$

Calculation of Valve Proving Test Time:

$$\text{Test Time} = 187,000 \times (P \times X \div C)$$

$$\text{Test Time} = 187,000 \times (2 \times 0.0864 \div 2500) = 12.9 \text{ sec.}$$

Round up to 13 seconds; enter 13 seconds into the VPS Setup.

Table 17. V₁ Upstream Volumes for Valves.

Models		Pipe Size NPT (inches)	Size
On/Off	POC		
	940-04543	1-1/2	0.0218
940-04539	940-04544	2	0.0218
940-04540	940-04545	2-1/2	0.0227
940-04541	940-045262	3	0.0227
940-04409	940-04451	4	0.0779

Table 18. V₂ Downstream Volumes for Valves.

Models		Pipe Size NPT (inches)	Size
On/Off	POC		
	940-04543	1-1/2	0.0238
940-04539	940-04544	2	0.0238
940-04540	940-04545	2-1/2	0.0245
940-04541	940-045262	3	0.0245
940-04409	940-04451	4	0.0801

Table 19. Schedule 40 Pipe Internal Cross-Sectional Area.

Pipe Size NPT (Inches)	Cross-Sectional Area (Sq. In.) "A"
1-1/4	1.498
1-1/2	2.036
2	3.356
2-1/2	4.788
3	7.393
4	12.730

Table 20. VPS Worksheet.

Item	Description	Information	Lookup Table	Results	Formula Item
V1	Upstream Valve Volume		17		V1
V2	Downstream Valve Volume		18		V2
D	Pipe Size NPT (in.)		19		A
L	Pipe Length (ft)		—		L
P	Valve Inlet Pressure (psig) ^a		—		P
C	Burner Maximum Firing (cf/hr) ^b		—		C

^a Divide inches w.c. by 2.77 to get psi.

^b Divide Btuh by 1000 to get cf/hr for natural gas or by 2550 to get cf/hr for LP gas.

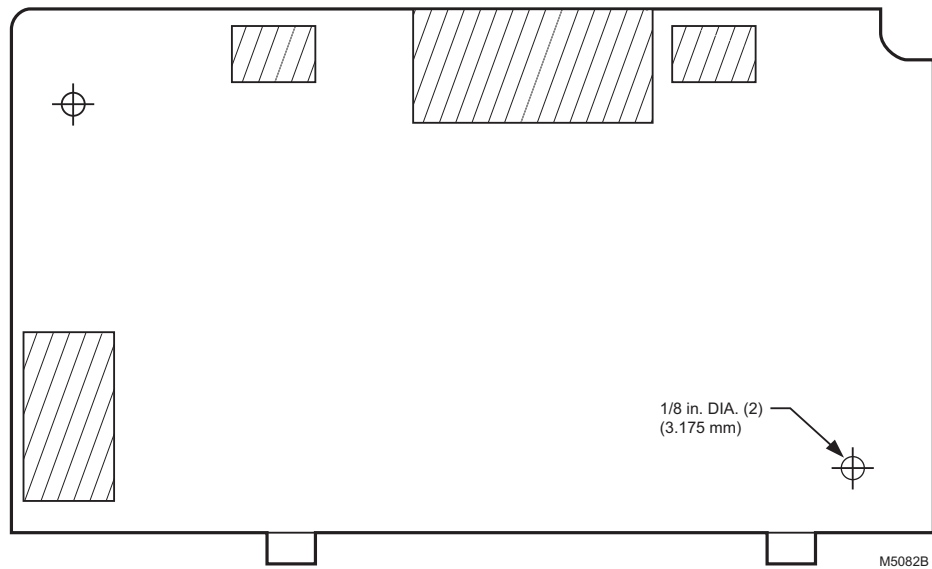

Fig. 50. Flush mounting of a Keyboard Display Module template.

