

SLC to CompactLogix Migration Guide



Important User Information

Solid-state equipment has operational characteristics differing from those of electromechanical equipment. Safety Guidelines for the Application, Installation and Maintenance of Solid State Controls (publication [SGI-1.1](#) available from your local Rockwell Automation® sales office or online at <http://www.rockwellautomation.com/literature/>) describes some important differences between solid-state equipment and hard-wired electromechanical devices. Because of this difference, and also because of the wide variety of uses for solid-state equipment, all persons responsible for applying this equipment must satisfy themselves that each intended application of this equipment is acceptable.

In no event will Rockwell Automation, Inc. be responsible or liable for indirect or consequential damages resulting from the use or application of this equipment.

The examples and diagrams in this manual are included solely for illustrative purposes. Because of the many variables and requirements associated with any particular installation, Rockwell Automation, Inc. cannot assume responsibility or liability for actual use based on the examples and diagrams.

No patent liability is assumed by Rockwell Automation, Inc. with respect to use of information, circuits, equipment, or software described in this manual.

Reproduction of the contents of this manual, in whole or in part, without written permission of Rockwell Automation, Inc., is prohibited.

Throughout this manual, when necessary, we use notes to make you aware of safety considerations.



WARNING: Identifies information about practices or circumstances that can cause an explosion in a hazardous environment, which may lead to personal injury or death, property damage, or economic loss.



ATTENTION: Identifies information about practices or circumstances that can lead to personal injury or death, property damage, or economic loss. Attentions help you identify a hazard, avoid a hazard, and recognize the consequence.



SHOCK HAZARD: Labels may be on or inside the equipment, for example, a drive or motor, to alert people that dangerous voltage may be present.



BURN HAZARD: Labels may be on or inside the equipment, for example, a drive or motor, to alert people that surfaces may reach dangerous temperatures.

IMPORTANT

Identifies information that is critical for successful application and understanding of the product.

Allen-Bradley, Rockwell Software, Rockwell Automation, CompactLogix, ControlLogix, Studio 5000, RSLogix, POINT I/O, FLEX, and TechConnect are trademarks of Rockwell Automation, Inc.

Trademarks not belonging to Rockwell Automation are property of their respective companies.

Preface	About This Publication.....	5
	Studio 5000 Environment	5
	Additional Resources.....	6
	 Chapter 1	
Overview	Why Convert.....	7
	What Is Needed.....	7
	SLC EtherNet/IP Adapter.....	8
	1747-AENTR Connections.....	9
	1747-AENTR and Rack Optimization.....	9
	Exclusive Owner, Input Only, Listen Only, and None Connection Types.....	9
	Add I/O Modules Online.....	10
	Using the 1747-AENTR Module in a Redundant Logix System ..	10
	SLC to Logix Memory Comparison	11
	Scan Time Comparison.....	11
	Local Rack SLC 500 I/O Modules.....	11
	Remote Rack SLC 500 I/O Modules.....	12
	Overall Performance Expectations	12
	Logix Controller Boot Time.....	13
	Synchronous Versus Asynchronous I/O Scans	13
	SLC I/O Local and Remote Rack Size	14
	Keeping I/O.....	14
	 Chapter 2	
Migration Considerations	Document Current System Layout	15
	PLC-5/SLC Interactive Migration Planner.....	15
	Define Future Requirements	17
	Device-level Ring Topologies.....	17
	Using DeviceNet Network.....	17
	Use of Advanced Modules.....	18
	Communication With an SLC Controller Over DH485, DH+, Ethernet, or Serial Networks	18
	1747-AENTR Backplane Power Considerations.....	19
	Using Integrated Architecture Builder to Plan Hardware Migration ..	20
	Replace Only the Local SLC Controller	20
	Replace the Local SLC System with CompactLogix System	26
	Adding a Chassis	33
	Network Connection Options for the Remote (SLC System) I/O Chassis.....	36
	Create Project Bill of Material	41

Conversion	Chapter 3	
	Introduction	43
	What to Expect from the Translation Tool	43
	Application Code Conversion	44
	Translate an RSLogix 500 Program to a Logix Designer Program	48
	Resolve the Differences in the New Logix Program	53
	SLC Controllers Data Tables and Logix Controller Tags.	53
	Resolve Program Code Issues	53
	Locating PCE Instructions	54
	Recognizing the Instructions	55
	Resolving PCE Instructions	55
	Common PCE Issues	55
	Map PLC/SLC Messages	56
	Resolving Issues with Physical I/O	57
	MOV Example	57
	CPS Example.	58
	Alias Example	60
	Replace SLC Processor and Adaptors	61
	Set the Network Address Switches	61
	Determine Power Requirements	62
	Install the Adapter Module in the Chassis	62
	Connect Your Adapter to the Ethernet/IP Network through RJ45 Connection.	64
	Replace Other Components.	65
	Appendix A	
Program Conversion Errors (PCE) Messages	Introduction	67
	Appendix B	
I/O Modules	Supported I/O Modules	69
	Unsupported I/O Modules.	70
	Appendix C	
Performance Expectations	73
	Appendix D	
Advanced Modules	Use Advanced Modules in a Logix System	75
Index	77

About This Publication

This document focuses on converting an SLC program to a Logix program and migrating the existing SLC I/O to an Ethernet network thereby helping to leverage the existing I/O and minimize cost and risk. This document can be used in the planning stages to help identify issues so that you can anticipate the work involved in the conversion. The ideas presented in this document require RSLogix™ 5000 software version 20 or later and RSLinx™ software version 2.59 or later.

This document focuses on converting an existing SLC program to a CompactLogix™ controller. If you want to convert your SLC program to a 1756 Logix controller the process is similar to what is presented in this manual.

Studio 5000 Environment

The Studio 5000™ Engineering and Design Environment combines engineering and design elements into a common environment. The first element in the Studio 5000 environment is the Logix Designer application. The Logix Designer application is the rebranding of RSLogix 5000 software and will continue to be the product to program Logix5000™ controllers for discrete, process, batch, motion, safety, and drive-based solutions.

The Studio 5000 environment was introduced in version 21. If you are using RSLogix software version 20, the steps are nearly identical.



The Studio 5000 environment is the foundation for the future of Rockwell Automation engineering design tools and capabilities. The Studio 5000 environment is the one place for design engineers to develop all of the elements of their control system.

Additional Resources

These documents contain additional information concerning related products from Rockwell Automation.

Resource	Description
SLC EtherNet Adaptor User Manual, publication 1747-UM076	Reference guide for the EtherNet/IP Adapter Module.
SLC EtherNet Adaptor Installation Instructions, publication 1747-INS21	Installation instructions for the EtherNet/IP Adapter Module.
Converting PLC-5 or SLC 500 Logic to Logix5550 Logic Reference Manual, publication 1756-RM085	Information on converting a PLC-5 or SLC 500 Logic to Logix5550.
CompactLogix 5370 Controllers User Manual, publication 1769-UM021	Describes how to install, use, and troubleshoot CompactLogix controllers.
CompactLogix Controllers Specifications Technical Data, publication 1769-TD005	Provides CompactLogix controllers specifications.
Industrial Automation Wiring and Grounding Guidelines, publication 1770-4.1	Provides general guidelines for installing a Rockwell Automation industrial system.
Product Certifications website, http://www.ab.com	Provides declarations of conformity, certificates, and other certification details.

You can view or download publications at <http://www.rockwellautomation.com/literature/>. To order paper copies of technical documentation, contact your local Allen-Bradley distributor or Rockwell Automation sales representative.

Overview

Why Convert

Migration solutions help you to achieve increased productivity and lessen your risk of maintaining your legacy equipment. Work with a supplier that has the product, service, and industry knowledge to partner with you on an upgrade strategy that will help you maximize your competitive advantage. Rockwell Automation works with you to outline a plan to accomplish the following:

- Lower conversion time and labor costs
- Reduce risk by preserving existing field wiring connections
- Lower engineering costs
- Minimize production downtime

What Is Needed

You need the following items for your migration project:

- Current SLC 500 control system
 - RSLogix 500 version 8.0 or later
- CompactLogix Controller
 - RSLogix 5000 software version 20, or later, with PLC/SLC Translation Tool version 2.2 or later

TIP The Studio 5000 environment, which includes the Logix Designer application, was introduced in version 21. If you are using RSLogix 5000 software version 20, the steps are nearly identical.

- Integrated Architecture Builder version 8.9.0.2 or later

1. Go to <http://www.rockwellautomation.com>.
2. Click the Support tab, under Selection, Design, and Configuration Tools.
3. Click System Configuration.

Figure 1 - System Configuration

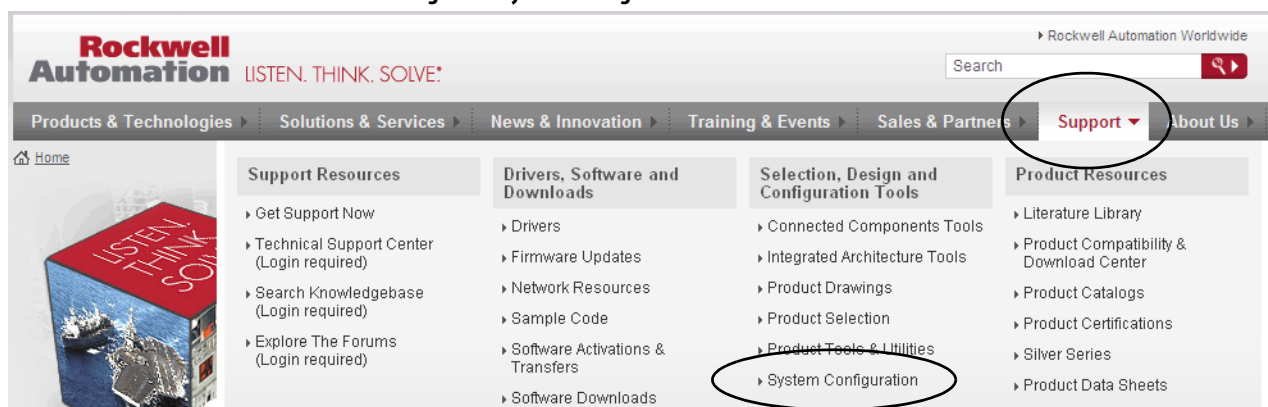

On the System Configuration page, you can order the full version or download the light version of Integrated Architecture Builder. The light version is fully functional but significantly smaller because it does not contain all of the individual product documentation supplied with the full version.

Figure 2 - Integrated Architecture Builder Download

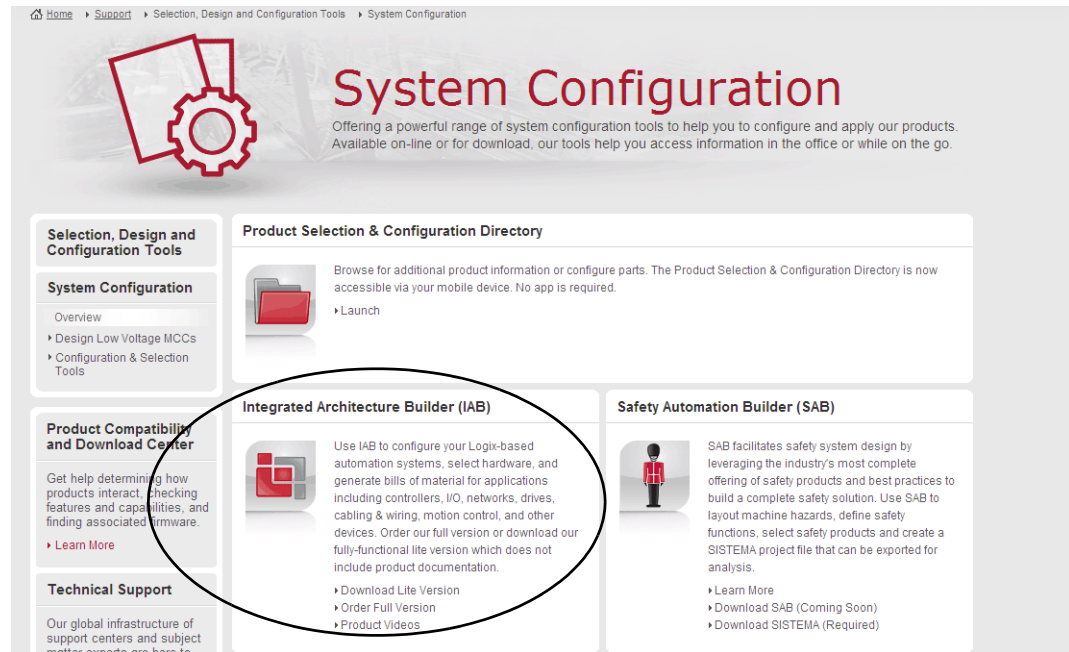

SLC EtherNet/IP Adapter

The 1747-AENTR adapter module enables CompactLogix and ControlLogix processors to control SLC I/O modules. The adapter is primarily designed to enable migration of existing SLC controlled systems to Logix-based systems.

The adapter mainly acts as a gateway between the SLC backplane and EtherNet/IP and typically replaces an SLC controller in the 1746 rack. On remote SLC racks, it replaces the 1747-ASB module or the ControlNet adapters, catalog numbers 1747-ACN15 and 1747-ACNR15.

Control of the backplane I/O is accomplished with a CompactLogix or ControlLogix controller communicating through an EtherNet/IP router in the Logix backplane, across EtherNet/IP, and into the 1747-AENTR gateway.

As a gateway between the SLC backplane and EtherNet/IP, the 1747-AENTR module is a CIP server (for both Explicit Messaging and I/O) on the Ethernet port, and an SLC host on the 1746 backplane.

Connections can be made to supported 1746 and 1747 analog, digital, and specialty I/O modules installed in the backplane.

IMPORTANT See [Appendix B](#) for a list of supported and unsupported I/O modules.

1747-AENTR Connections

Exclusive Owner, Input Only, and Listen Only connections are Class 1 connections. The 1747-AENTR module supports a combined total of 96 Class 1 connections:

- One Exclusive Owner connection per slot
- A combination of 5 Input Only or Listen Only connections per slot

The 1747-AENTR module supports a maximum of 8 Class 3 connections. Class 3 connections are typically a connected ladder-triggered MSG instruction to the 1747-AENTR module.

1747-AENTR and Rack Optimization

A major difference between using the 1747-AENTR adapter with SLC I/O modules and any other Logix compatible I/O system is that the 1747-AENTR adapter does not support a Rack Optimized connection type. This means that each module is an individual connection to the controller. These connections must be taken into account when converting the SLC controller. The main considerations are the effect on the Logix controller's total number of connections and the allowable RPIs to the modules in the 1747-AENTR chassis.

Exclusive Owner, Input Only, Listen Only, and None Connection Types

People familiar with SLC programming and I/O may not be familiar with how Logix handles programming and I/O. In simple terms, all I/O in a Logix controller is placed in an I/O tree. All I/O modules in the I/O tree can have multiple types of connections that transfer the I/O data into the Logix controller's memory. Below are some basic definitions of the types of connections that can be made to various 1746 I/O modules.

- None - A method of establishing communication to a 1747-AENTR module that enables connection to individual modules within the 1747-AENTR module chassis by using individual connections. After a None connection is configured to a 1747-AENTR module, each module that you desire to communicate through this connection must also be configured under the 1747-AENTR module by using any type of individual module connection (Exclusive Owner, Input Only, or Listen Only). Only the 1747-AENTR module supports a None connection type. A None connection does not affect the 96 total available Class 1 I/O connections on the 1747-AENTR module.

- Exclusive Owner - There can be only one Exclusive Owner connection to the each module. The Exclusive Owner connection is the one and only connection that controls outputs (analog or discrete) to that module. The Exclusive Owner connection is the one and only connection to send configuration data to that module. An Exclusive Owner connection to a device is the only connection that determines the mode (Prog or Run) of that particular device. Each Exclusive Owner connection does subtract 1 from the 96 total available Class 1 I/O connections on the 1747-AENTR module.
- Input Only - There can be as many as 5 Input Only connections to the same module. This connection type lets multiple Logix controllers receive incoming data from the same I/O module. If the connection is to an I/O device that requires configuration or output data, the Input Only connection does not send any configuration or output data. You can get Input Only data with or without an existing Exclusive Owner connection. Each Input Only connection subtracts one from the 96 total available Class 1 I/O connections on the 1747-AENTR module.
- Listen Only - There can be as many as 5 Listen Only connections to the same module. This connection type is identical to an Input Only connection with two differences:
 - Either an Exclusive Owner or Input Only connection must exist and be working to the I/O module before a Listen Only connection can work.
 - The Exclusive Owner or Input Only connection and the Listen Only connection must all be set to Multicast. Each Listen Only connection subtracts 1 from the 96 total available Class 1 I/O connections on the 1747-AENTR adapter.

Add I/O Modules Online

RSLogix 5000 software, version 15.02.00 and later, or Studio 5000 environment, version 21.00.00 and later, the 1747-AENTR module, and all supported 1746 I/O modules support adding I/O modules online and Module Discovery. However, this feature is supported only in 1756 controllers. CompactLogix controllers do not support adding I/O modules online or Module Discovery.

Using the 1747-AENTR Module in a Redundant Logix System

The 1747-AENTR is not compatible for use in a ControlLogix redundant system using a 1756-SRM, 1756-RM, or 1756-RM2.

SLC to Logix Memory Comparison

When choosing a Logix controller to migrate to, you must consider the memory size of your existing SLC program and in what type of Logix controller the program will fit after conversion. SLC maximum memory sizes vary from 1 KB to 64 KB. Logix controllers vary in maximum memory size from about 380 KB to about 33 MB. While no two SLC programs' memory usage before and after conversion is the same, a good rule of thumb is that a full 32 KB SLC program converts to a Logix program size of about 360 KB. So in general, SLC programs of less than 32 KB fit into any type of Logix controller while a full 64 KB SLC program fits only in Logix controllers with at least about 800 KB of memory.

Scan Time Comparison

The Logix controller has a significant advantage over the SLC controller in regard to program scan time. While each situation is unique, it is likely you'll see a reduction in overall scan time when you convert to a 1756-L7x controller or a CompactLogix 5370 controller. In many cases a scan time reduction is beneficial, but there can be instances where this is not ideal and can disrupt an existing process. Consider this in your conversion process and make the necessary adjustments to scan time as needed.

While some conversions involve converting a single SLC controller to a single Logix controller, there are cases where you want to convert multiple SLC controllers and combine them into a single Logix controller. With the significant decrease in scan time, this can be possible without any decrease in throughput or performance.

After the conversion, you could expect a decrease of 50...80% in overall program scan when running in a Logix controller as compared to an SLC controller. For more information on converting an SLC 500 program, refer to the Converting PLC-5 or SLC 500 Logic to Logix-Based Logic, publication [1756-RM085](#).

Local Rack SLC 500 I/O Modules

1746 I/O modules contained within the same chassis as the SLC controller are considered local I/O. In simple terms, the SLC controller can be removed and a 1747-AENTR installed in its place. It is important to note that SLC 500 local I/O, both analog and discrete, was generally scanned fairly quickly, with the major contributor to throughput being program scan. Because SLC 500 local I/O is changed during the system conversion to remote I/O on Ethernet, I/O scan time is greatly reduced. This means that when selecting the RPI of the I/O in the chassis with the 1747-AENTR module, you must balance desired performance with RPIs that are valid for the number of I/O modules in the chassis.

IMPORTANT Modules requiring G-file configurations cannot be in a remote rack to a Logix controller.

See [Appendix C](#) for information on performance expectations.

Remote Rack SLC 500 I/O Modules

IMPORTANT See [Appendix B](#) for a list of supported and unsupported I/O modules.

Many SLC systems have I/O remotely located from the SLC controller. The I/O can be scanned by a 1747-SCNR (ControlNet) module or a 1747-SN (RIO) module. The adapters used can be a 1747-ACNR (ControlNet) module or a 1747-ASB (RIO) module. The 1747-SCNR/1747-SN modules scan I/O and place the data in a combination of I1 Input, O0 Output, M1 Input, and M0 Output files. Because the 1747-SCNR module and the 1747-SN module are not supported, they are removed from the converted system and the 1747-ACNR module and the 1747-ASB module are replaced with a 1747-AENTR module and scanned directly by the Logix controller. After the replacement of the various modules the data must be MOVED/COPied to/from the original I1, O0, M1, and M0 locations to the new Logix tag locations. The exact process of these moves is beyond the scope of this document.

The scanning of the remotely-located I/O in the SLC system was at a slower rate than the scanning of local SLC I/O. After conversion to a Logix system, the scan rate of the remote I/O scanned on Ethernet via the 1747-AENTR module will be similar to that of the original SLC system.

Some SLC systems can perform Block Transfer Reads (BTR) and Block Transfer Writes (BTW) over remote I/O via the 1747-SN module. This is a specialized function and requires a more detailed description. The 1747-AENTR module does not support the 1747-SN module, but the racks communicated with by the 1747-SN module contain a 1747-ASB module that can be replaced by a 1747-AENTR module. If your existing SLC system is using BTR and BTW instructions over remote I/O via the 1747-SN module, the BTR/BTW can be replaced by a module connection in the Logix Designer application. Expect this part of the conversion to take additional work and time.

Overall Performance Expectations

While each conversion situation is unique, it is likely that the scanning of I/O could be slower in a Logix system while the program scan is faster. Overall performance and throughput is likely to be better than the existing system.

If the current system has very stringent performance characteristics, we recommend you perform a more detailed performance analysis to verify the Logix performance in advance of your migration.

Logix Controller Boot Time

As Rockwell Automation moves forward with technology and adds more functionality into the controllers, boot time can be affected. Here are some of the reasons:

- More tasks are performed at startup, such as: memory validity checks, safety diagnostics, controller health, and security tests.
- As memory sizes increase, so does the power required to back up that memory.
- The controller does not enter the 'RUN' condition until there is enough energy stored to tolerate a potential loss of power. Larger capacitors require longer charge-up times.
- Certification requirements continue to drive more start-up diagnostics and code validation.
- SLC processors' power-up times were relatively small, taking only several seconds. Some Logix controllers can take as long as 40 seconds to power up.

Therefore, you can expect the boot time in the Logix controllers to be greater than in your SLC controllers.

Synchronous Versus Asynchronous I/O Scans

The SLC 500 processor maps I/O data into Input and Output data table files. The I/O data is updated synchronously to the program scan so you know you have current values each time the processor begins a program scan and that the I/O data does not change during the program scan. A Logix controller references I/O that is updated asynchronously to the logic scan.

If you need to maintain I/O data integrity throughout the program scan and/or you need to maintain synchronous I/O data transfers in the Logic controller you must use a CPS copy instruction. Please reference KB ID 50235 for more information on how to use the CPS instruction.

SLC I/O Local and Remote Rack Size

The SLC 500 systems had a maximum single-chassis size of 13 slots, through the use of various cables, multiple chassis could be connected together to create an I/O rack that extended up to 30 slots. RSLogix 5000 software version 20.00.00 with the 1747-AENTR module version 1.1 supports a maximum chassis size of 13 slots and only one chassis. Logix Designer Application version 21.00.00 or later with the 1747-AENTR module version 2.1 supports up to 30 modules and up to 3 chassis.

IMPORTANT RSLogix 5000 software version 20.00.00 with any version of the 1747-AENTR module supports a single chassis with up to 13 slots. You must have Logix Designer Application version 21.00.00 or later and a 1747-AENTR module version 2.1 or later to support up to 30 modules.

Keeping I/O

With the introduction of the 1747-AENTR module, you can potentially lower the risk, decrease conversion time, and lower the cost of converting an SLC system to a Logix system. RSLogix 5000 version 20 and later lets you keep your existing SLC I/O modules while migrating to a Logix controller. The existing SLC I/O can be added to the Logix controllers' I/O tree by replacing the SLC controller or SLC adapter with a 1747-AENTR module. No changes are needed to individual SLC I/O modules, but new EDS files have been developed for the existing supported modules. These new EDS files are installed with RSLinx software version 2.59. The EDS files can be verified in RSLinx software by viewing the modules' EDS file. The correct EDS files have a ModDate of 2011; incorrect files have a ModDate of 1999.

IMPORTANT See [Appendix B](#) for a list of supported and unsupported I/O modules.

RSLinx software version 2.59 installs new EDS files for all 1746 supported I/O modules. However, the 1747-AENTR EDS file installed by RSLinx software version 2.59 is not the latest version. You must update the 1747-AENTR EDS file to the latest version, which is currently version 2.3. Common symptoms of creating an RSLogix 5000 project with an incorrect 1747-AENTR EDS file include the following:

- Incorrectly getting 'Module Configuration Rejected fault code 16#0009' to a properly configured module under the 1747-AENTR module
- Inability to convert an RSLogix 5000 project from one controller type to another
- Inability to open a valid project on a different computer

The corrective actions include uninstalling the incorrect EDS file and updating to the correct version EDS file, possibly deleting the 1747-AENTR module and its children from the I/O tree, and exporting and importing the project. If you are using EDS revisions earlier than 2.3 and you right-click on the 1747-AENTR module, you do not see a selection for 'Upload EDS from device'. If you are using EDS revision 2.3 or later and you right-click the 1747-AENTR module, you see a selection for 'Upload EDS from device'.

Migration Considerations

Document Current System Layout

Begin planning your migration by documenting your existing system as a reference point. This enables you to consider the available options and find a solution that best meets your existing and future requirements. The PLC-5/SLC Interactive Migration Planner tool provides general guidelines as you migrate your SLC 500 system to a Logix based solution.

PLC-5/SLC Interactive Migration Planner

Go to <http://www.rockwellautomation.com> and click on the Products & Technologies tab, under Our Portfolios, click Integrated Architecture.

1. Go to <http://www.rockwellautomation.com>.
2. Click the Products & Technologies tab.
3. Under Our Portfolios, click Integrated Architecture.

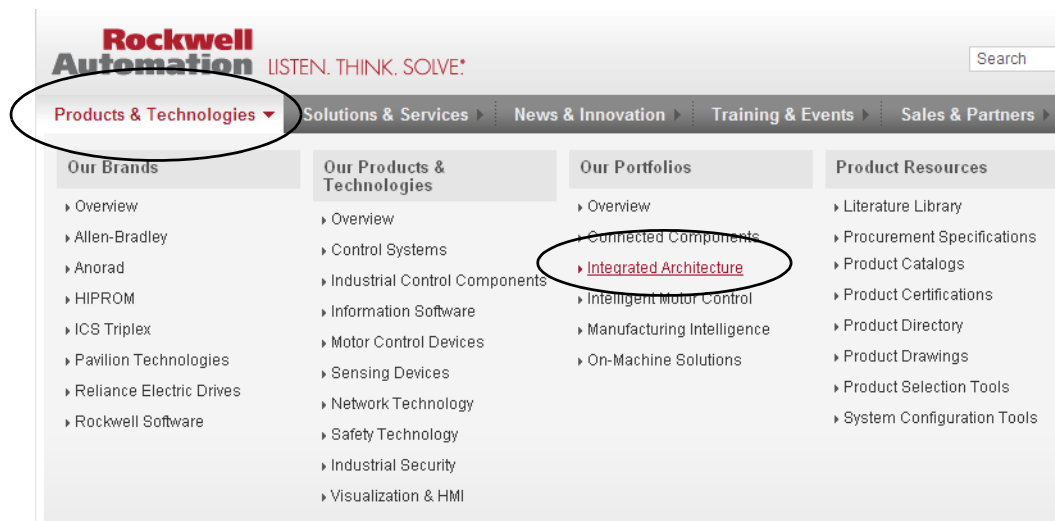

4. Under Application Tools, click Integrated Architecture Tools.

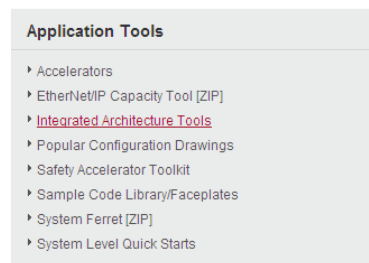

5. Click the Choosing An Architecture tab.
6. Download the PLC-5/SLC Interactive Migration Tool.

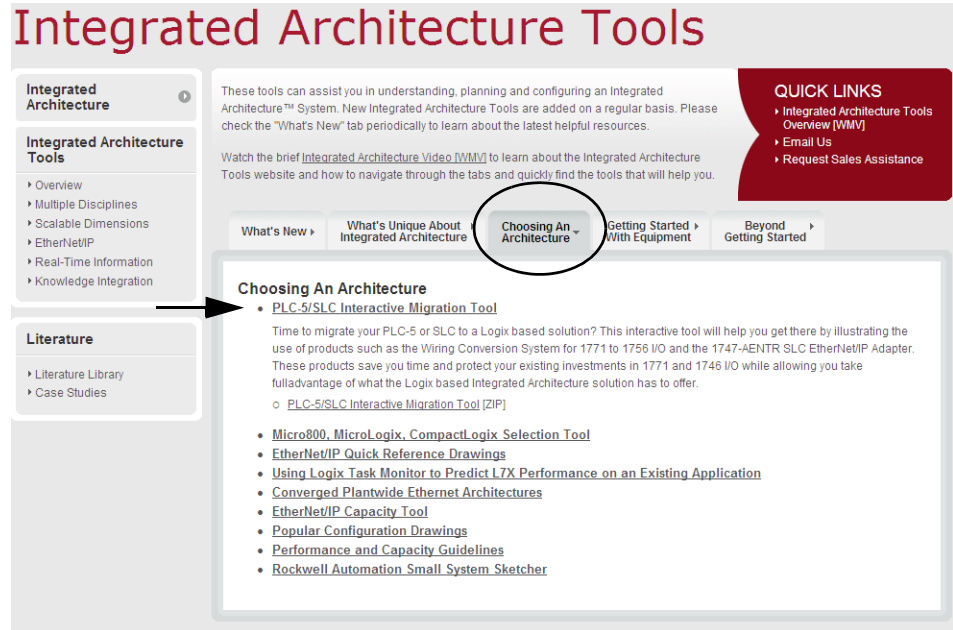

7. Use the tool to help plan your migration.

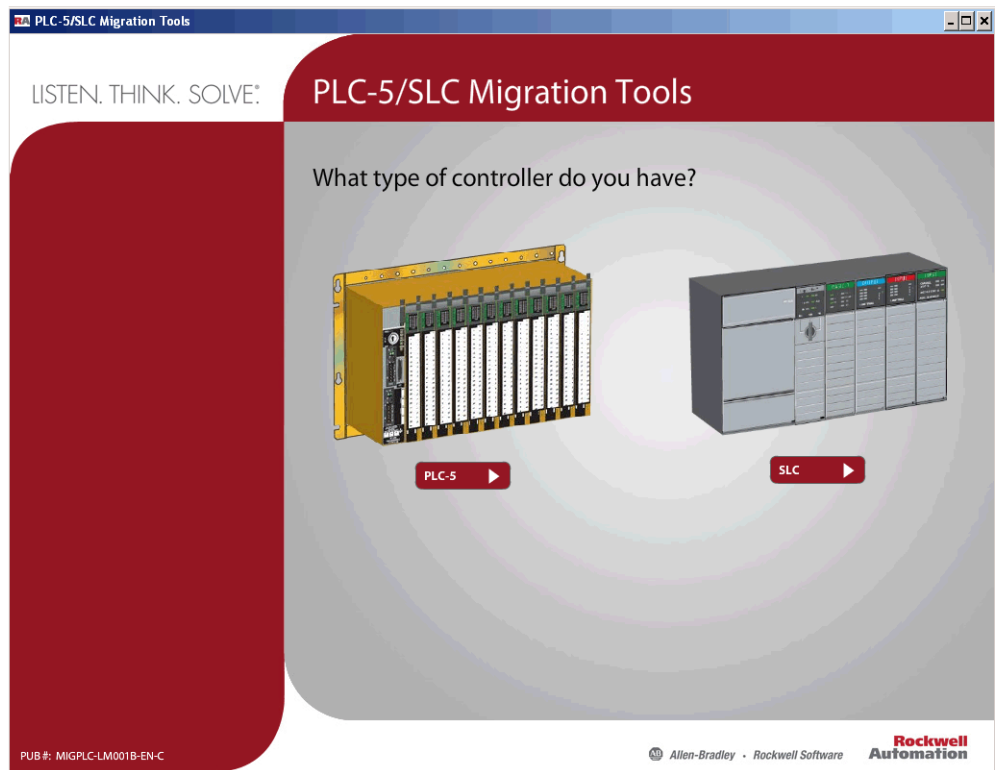

Define Future Requirements

As you investigate the prospect of upgrading current control systems to newer technology, it is important to factor in all aspects of the migration. Deciding how to phase in the new system can be challenging due to conversion time and physical considerations. Rockwell Automation has tools to assist with the conversion of the program code to minimize the engineering design time. But, what about the physical layout of the new system? Does it make more sense to leave the existing legacy I/O and wiring in place and save the I/O conversion for a later date? Or should the entire system be upgraded all at once? How might the hardware costs for each of these scenarios be affected?

The process for converting your SLC program to a 1756 Logix controller is similar to what is presented in this manual.

Device-level Ring Topologies

While the 1747-AENTR adapter can be a member of a ring, the adapter does not support being an Active Ring Supervisor or a Back-up Supervisor. For more information on Ethernet network rings and ring supervisors, see the EtherNet/IP Embedded Switch Technology Application Guide, publication [ENET-AP005](#).

Using DeviceNet Network

Existing SLC systems that use 1747-SDN modules need to replace the 1747-SDN module with a different DeviceNet scanner because the 1747-SDN module is not supported by the 1747-AENTR module. Depending on the application and Logix processor selected, likely choices include a 1756-DNB module, a 1769-SDN module, or a 1788-EN2DN module.

The 1747-SDN module scans I/O and places the data in a combination of I1 Input, O0 Output, M1 Input, and M0 Output files. The 1747-SDN module needs to be replaced in the converted system with a different DeviceNet scanner. After the replacement, the original 1747-SDN module data must be MOVED/COPIED to/from the original I1, O0, M1, and M0 locations to the new Logix tag locations.

IMPORTANT The exact process of these moves is beyond the scope of this document; expect this part of the conversion to take additional work and time.

Use of Advanced Modules

The 1746-HSCE, 1746-QS, 1746-BAS/B, and the 1746-BAS-T modules are considered advanced modules because they transfer Input data, Output data, and in an SLC environment M0 and M1 files. In the Logix Designer application, connections are established to these modules by using an Exclusive Owner Advanced connection. The Exclusive Owner Advanced connection enables the transfer of the additional data supplied by the 1746 modules M0 and M1 files. Advanced connections transfer Input, Output, M0, and M1 data from the 1746 module via a single connection in the Logix Designer application. This data in the RSLogix 500 environment was obtained in the equivalent of two separate transactions.

Advanced modules do require some additional set up and configuration. Advanced modules also do not have descriptive tag names like most non-advanced 1746 I/O modules. All Advanced modules require additional steps and programming to migrate.

See [Use Advanced Modules in a Logix System on page 75](#) for information.

Communication With an SLC Controller Over DH485, DH+, Ethernet, or Serial Networks

Be aware of other networks and take them into account when planning a conversion. This is a brief overview of networks that can be present in the existing architecture.

TIP You can also use products from various Rockwell Encompass Partners for support on a specific protocol.

If after the conversion you need to keep communication with existing nodes, various communication modules can facilitate this messaging.

Network	Modules	See Publication
DH485 network	1756-DH485 communication module	1756-UM532
DH+ network	1756-DHRIO communication module	1756-UM514
Ethernet network	1756 Ethernet modules	ENET-UM001

You can take advantage of the built-in RS232 port on the SLC controller as an inexpensive way to communicate to other devices. If this communication port is to be maintained after the conversion, you need to consider the following.

- The SLC serial port supported multiple protocols most of which are also supported by Logix controllers. However, the SLC controller supported Modbus RTU Master as a built in protocol. Logix controllers do not offer Modbus as a built in protocol, but there is application code that can configure the Logix controller to talk through the serial port as either a Modbus RTU master or slave. See KB ID 42662 for details.
- Not all Logix controllers have a serial port. During the design phase of the conversion, be sure that the selected Logix controller supports serial communication if it is needed. Note that Logix controllers with a USB port cannot access that port for serial communication.

TIP For RS-232 network communication, you can use a 1734-RS232 module or other third party options available from companies such as ProSoft.

1747-AENTR Backplane Power Considerations

The 1747-AENTR adapter module uses 470 mA at 5V DC of chassis backplane power and 0 mA at 24V DC. In general the 1747-AENTR module replaces some type of SLC controller, 1747-ANC(R) module, or 1747-ASB module.

Depending on exact module configuration of the chassis and exact type of 1746 power supply used, inserting a 1747-AENTR module into the existing chassis can put you over the current rating of the power supply. Before the conversion, investigate what type of module the 1747-AENTR module is replacing, and does inserting the 1747-AENTR module into the chassis push you over the current limit of the power supply.

TIP A 5/01 controller uses 90 mA at 5V DC, a 5/03 controller uses 500 mA at 5V DC, a 5/04 controller uses 1000 mA at 5V DC, a 1747-ASB module uses 375 mA at 5V DC, and a 1747-ACNR module uses 900 mA at 5V DC. Check the most recent publication to verify each modules current specification.

Using Integrated Architecture Builder to Plan Hardware Migration

Once you have planned your overall migration approach, let Integrated Architecture Builder (IAB) help plan the details. The SLC migration wizard embedded in IAB steps you through the system configuration process, letting you make the decisions on which components you prefer to keep and reuse and which components you prefer to replace. If you choose to reuse the SLC I/O modules, IAB verifies module support and power supply loading and helps you layout the new EtherNet/IP network.

This section uses the SLC/PLC Migration Wizard within Integrated Architecture Builder to assist with the conversion of the existing SLC hardware to a CompactLogix system. The process for converting your SLC program to a 1756 Logix controller is similar to what is presented in this manual.

Replace Only the Local SLC Controller

1. Go to Start > Programs > Rockwell Automation > Integrated Architecture Builder > Integrated Architecture Builder or double-click the Integrated Architecture Builder icon on the computer desktop to launch IAB.

The IAB opening dialog box appears.

2. Click New Project.

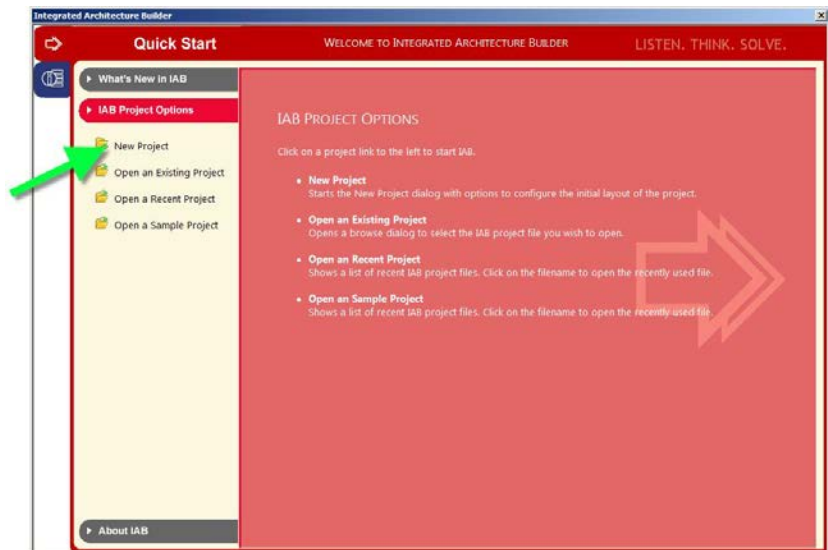

3. In the **Workspace Name** text box, type an appropriate name, such as 'SLC Migration Wizard', and click **OK**.

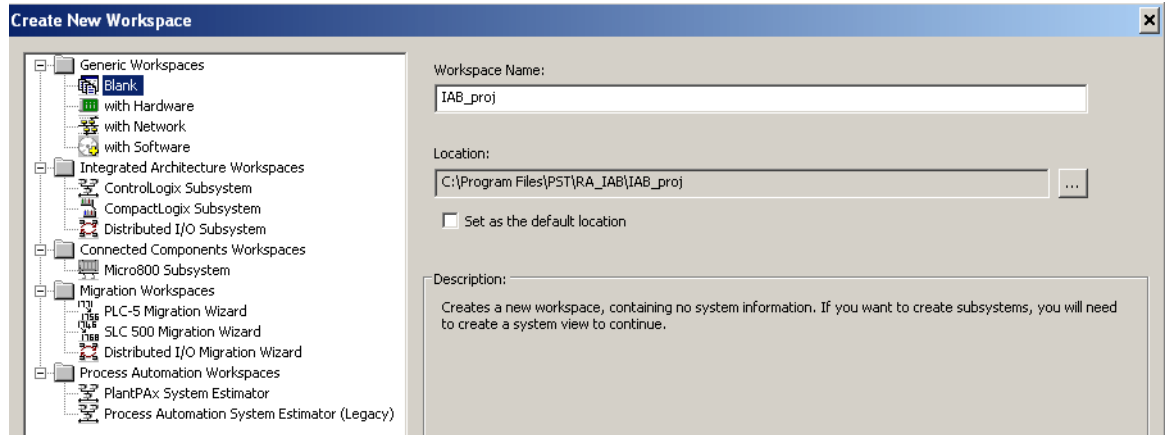

4. Under **Wizard View**, click **SLC Migration**.

TIP Clicking on the wizards listed under **Available Assistants** provides an overview of the wizard.

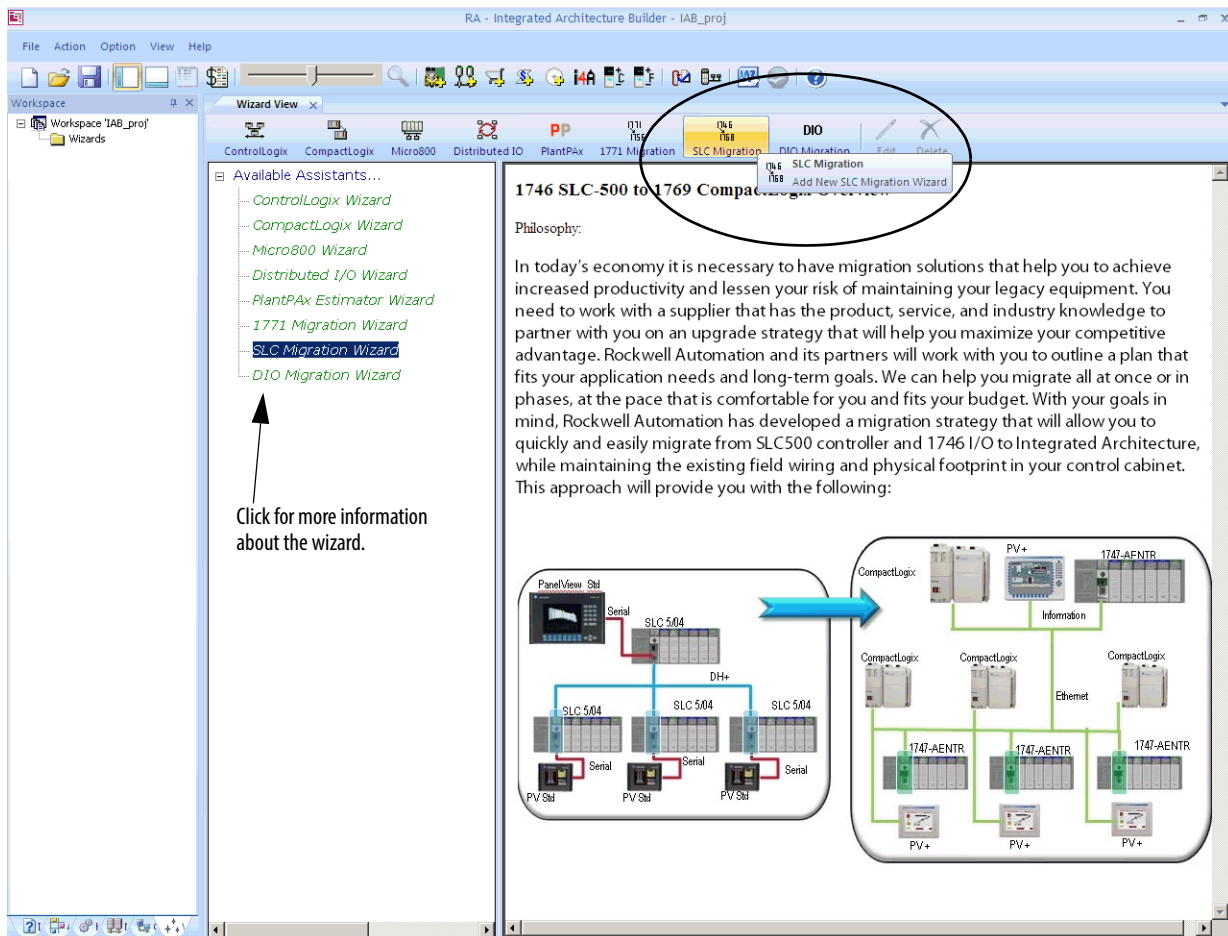

5. In the SLC Migration Chassis Selection dialog box, click Add Chassis. IAB opens the Add Chassis dialog box.

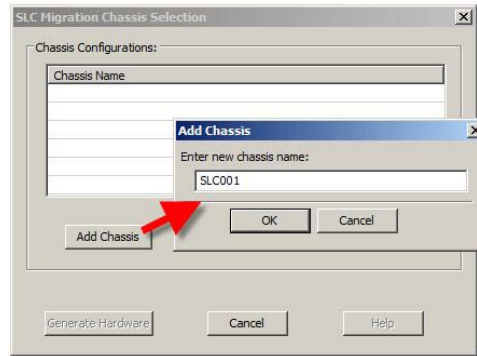

6. Click OK to accept the default name (SLC001) for the new chassis.

IAB opens the SLC Migration Module Selection dialog box. This is where you make the conversion selections for this chassis. Notice the different areas of this window.

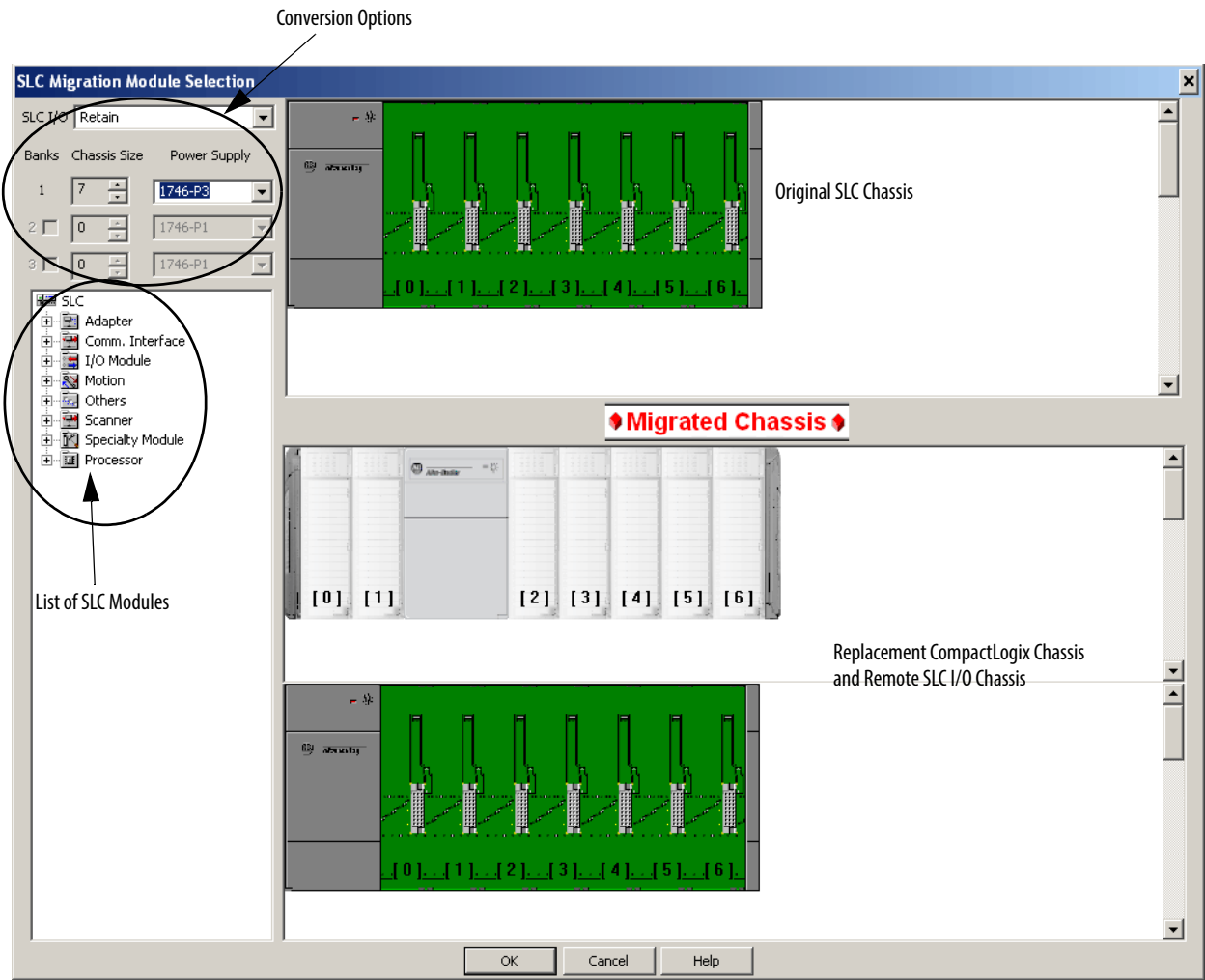

7. Select your chassis size and choose power supply.

8. From the Processor module list, expand the Processor heading and drag your processor module to slot 0 of the SLC chassis.

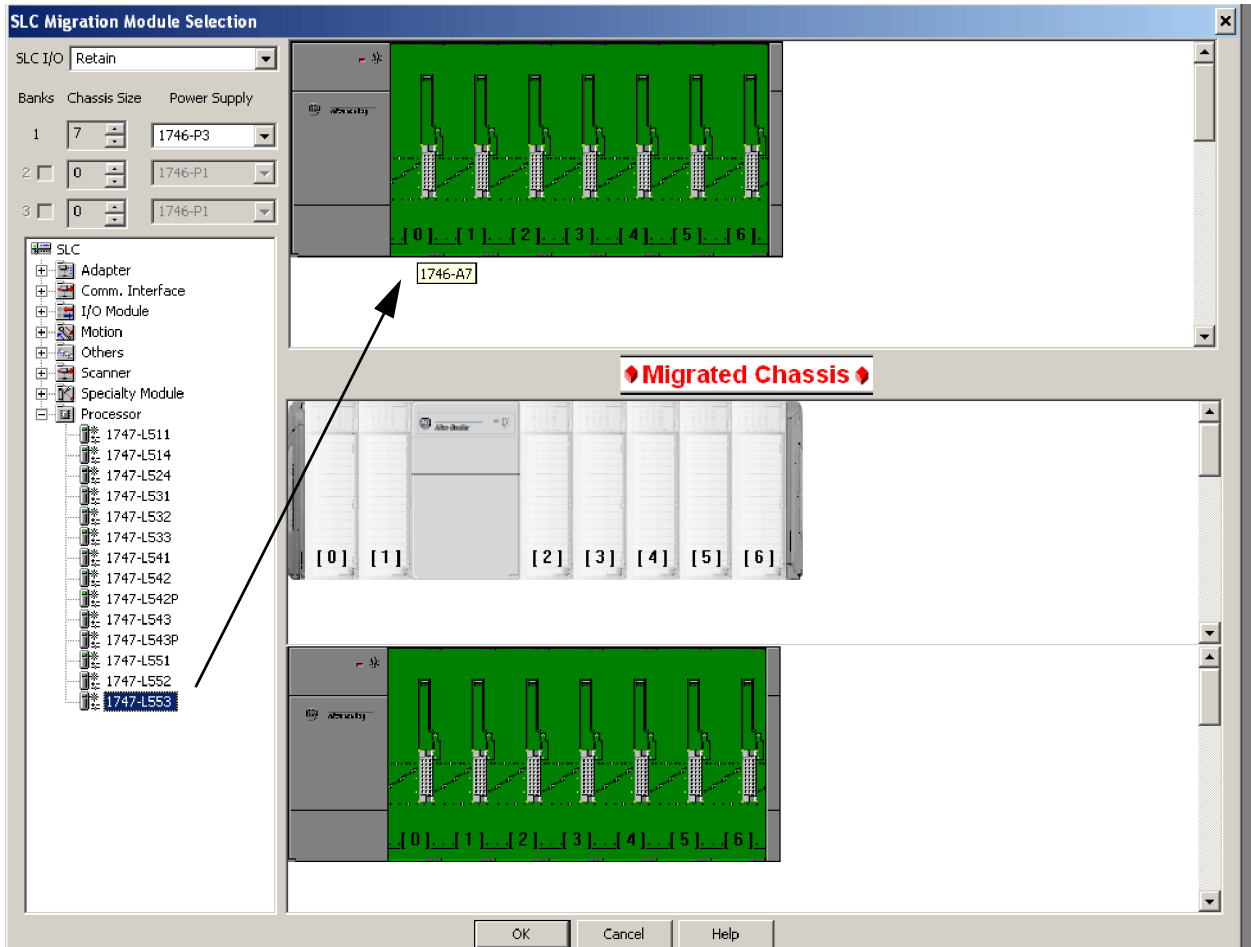

Because IAB has found more than one possible CompactLogix controller migration option, the SLC Migration Conflict Resolution Dialog box appears.

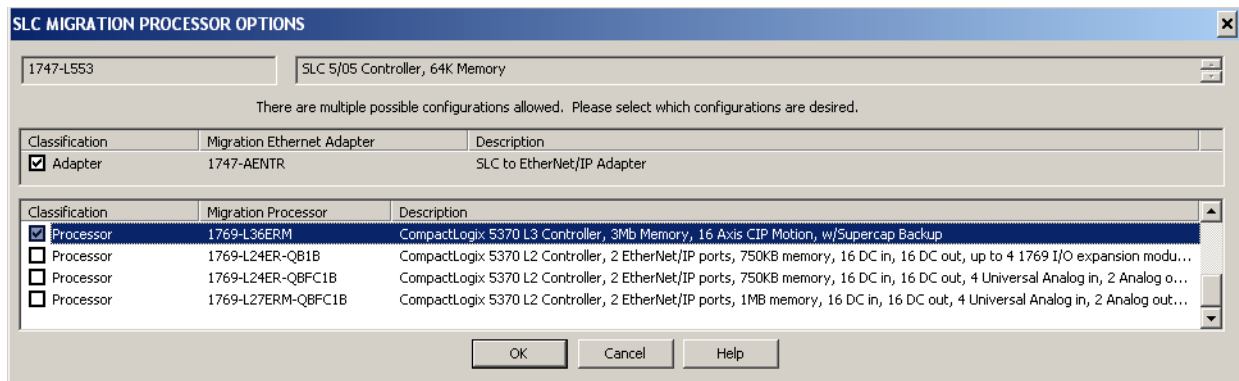

TIP Conflict resolution dialogs appear when you must make a decision about the conversion. The information in the dialog box is specific to the action you are performing. In this case, we must select the CompactLogix processor that we wish to use.

9. Select a processor in the list and click OK.

In this example, we show the 1769-L36ERM module.

IAB adds processors to both the SLC chassis and the replacement CompactLogix chassis. Additionally, IAB also adds a 1747-AENTR Ethernet adapter module to the retained I/O SLC chassis at the bottom of the display.

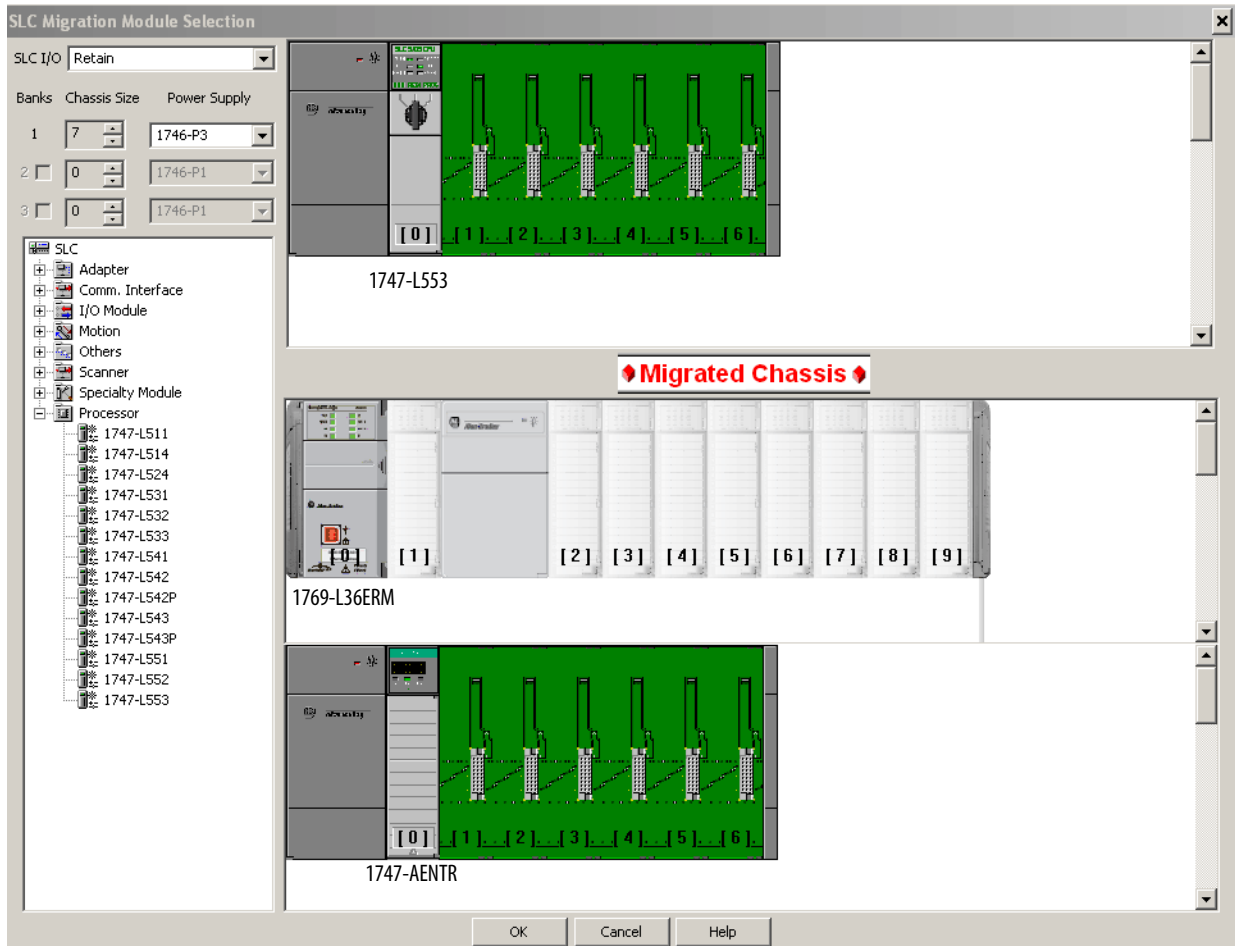

10. Repeat steps 8 and 9 to fill remaining slots.

TIP If you incorrectly place a module, simply right-click the module and click Remove Module to try again.

The majority of 1746 and 1747 discrete, analog, and specialty modules are compatible with the 1747-AENTR adapter.

For a list of supported and unsupported modules, see [I/O Modules on page 69](#).

If you have a module that is not compatible, the following warning occurs.

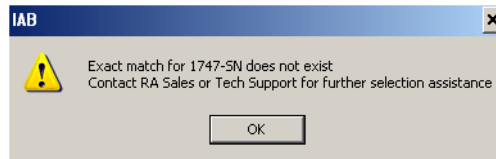

IMPORTANT Modules not supported as part of a retained I/O solution, when connected to a Logix controller, are not placed into the lower chassis in IAB.

11. Once the local SLC chassis is complete, click OK.
12. In the SLC Migration Chassis Selection dialog box, click Generate Hardware to create the wizard-defined CompactLogix configuration in IAB.

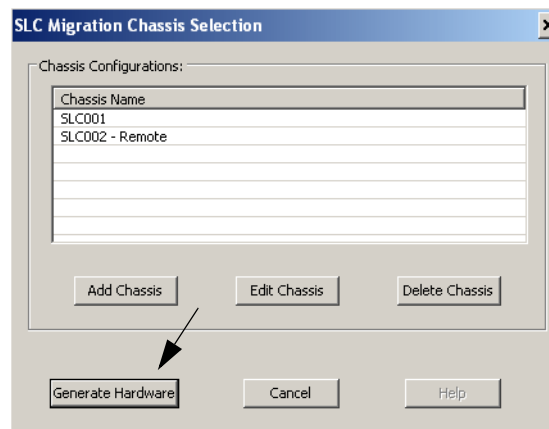

13. Click the Hardware tab  in the lower left corner of the IAB window.
14. Click the SLC_Migration.1_SLC001 chassis to see the hardware.

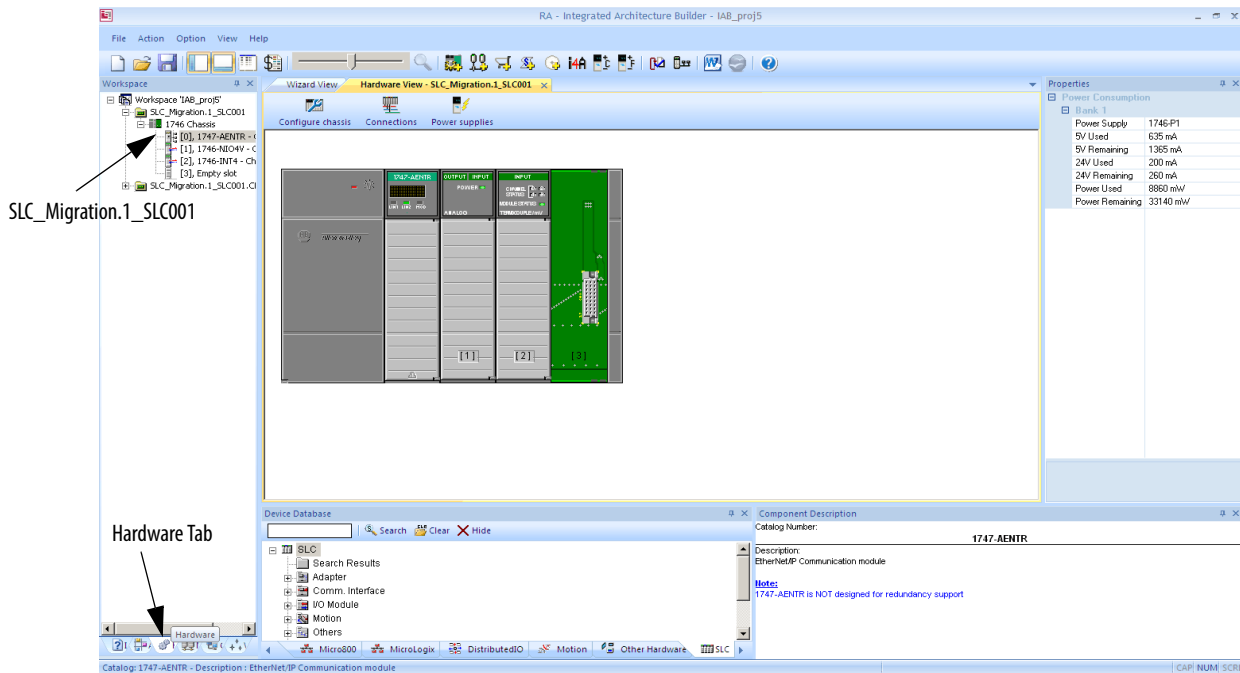

This chassis contains all of the SLC I/O from the local rack that we replaced. A 1747-AENTR module has been added to connect this I/O remotely over Ethernet to the CompactLogix controller that is replacing our SLC processor.

15. Click the save icon to save your project.

Replace the Local SLC System with CompactLogix System

Although retaining the SLC I/O when converting to a Logix system can save on re-wiring costs, adding a controller and a power supply to an existing control panel can prove to be impossible due to physical space limitations. In such cases, the best SLC conversion solution can actually involve converting the I/O to the 1769 or POINT I/O™ platforms in addition to converting to a Logix controller.

1. Go to Start > Programs > Rockwell Automation > Integrated Architecture Builder > Integrated Architecture Builder or double-click the Integrated Architecture Builder icon on the computer desktop to launch IAB.

The IAB opening dialog box appears.

2. Click New Project.

The Create New Workspace dialog box appears.

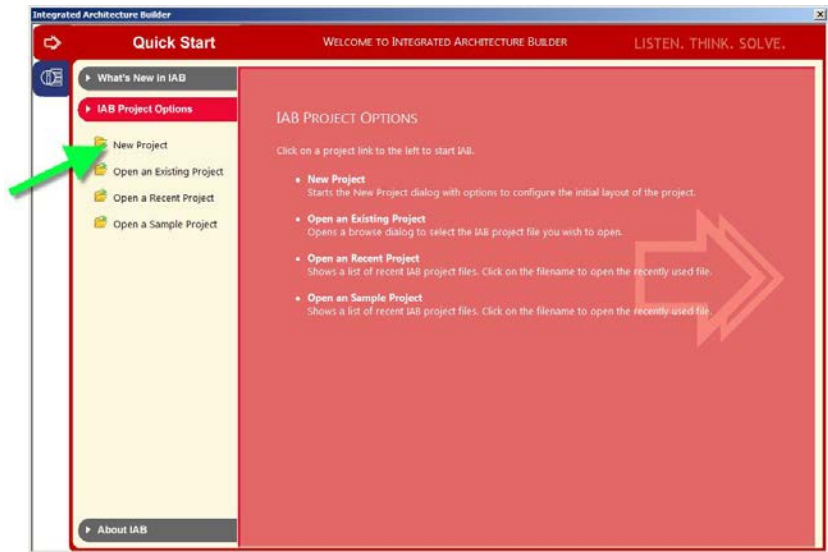

3. In the Workspace Name text box, type an appropriate name, such as 'SLC Migration Wizard', and click OK.

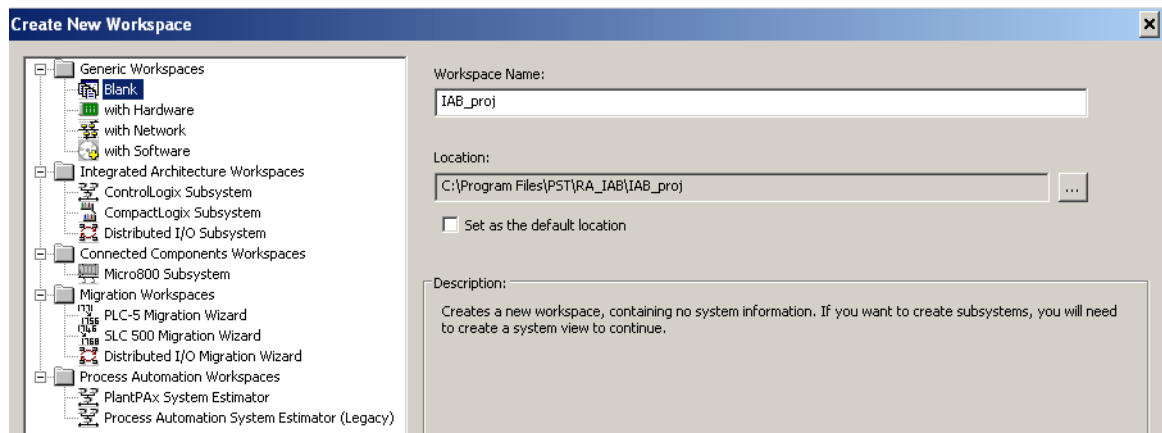

4. Click SLC Migration in the Wizard View.

TIP Click Available Assistants for more information about each assistant.

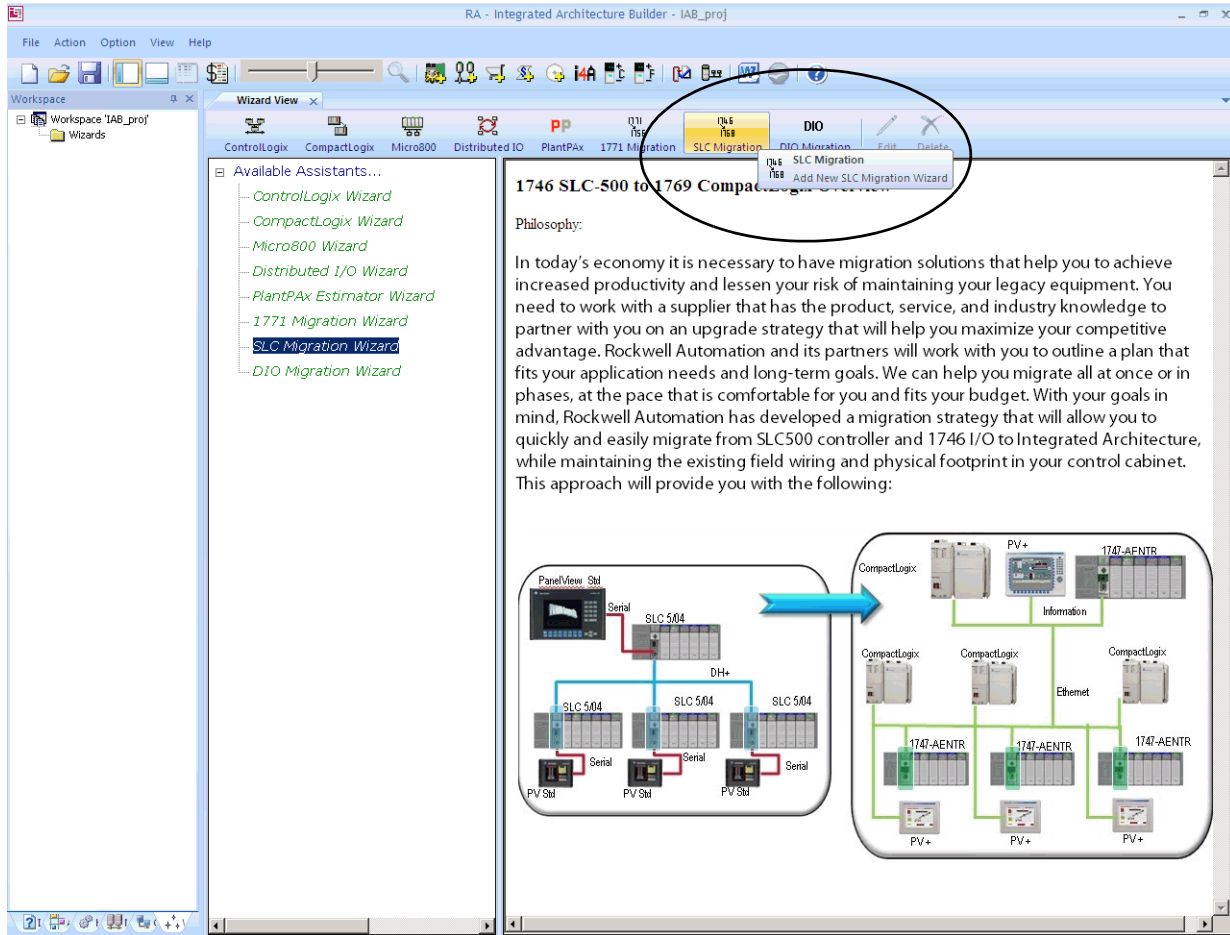

5. In the SLC Migration Chassis Selection dialog box, click Add Chassis.

IAB opens the Add Chassis dialog box.

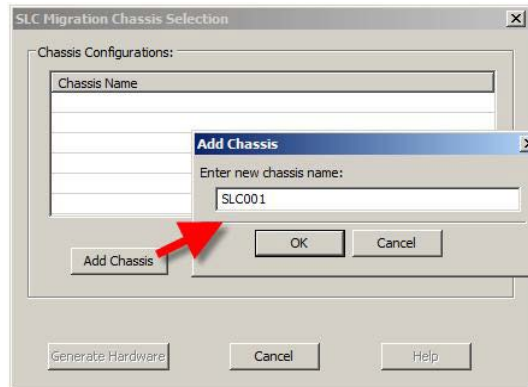

6. Click OK in the Add Chassis dialog box to accept the default name for the new chassis (SLC001).

IAB opens the SLC Migration Module Selection dialog box. This is where you make the conversion selections for this chassis. Notice the different areas of this window.

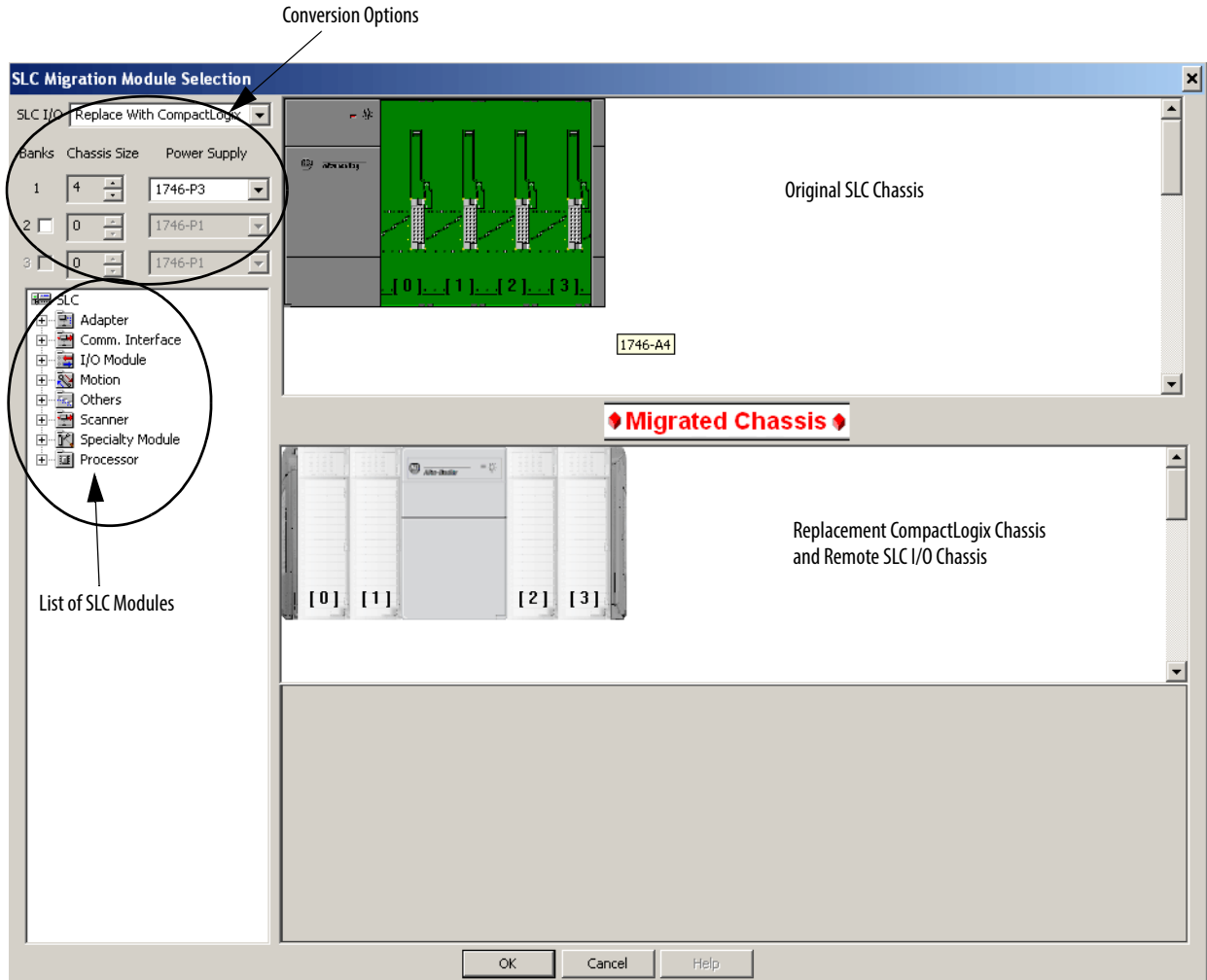

7. Select your chassis size and choose power supply.

8. From the Processor module list, expand the Processor heading and drag your processor module to slot 0 of the SLC chassis.

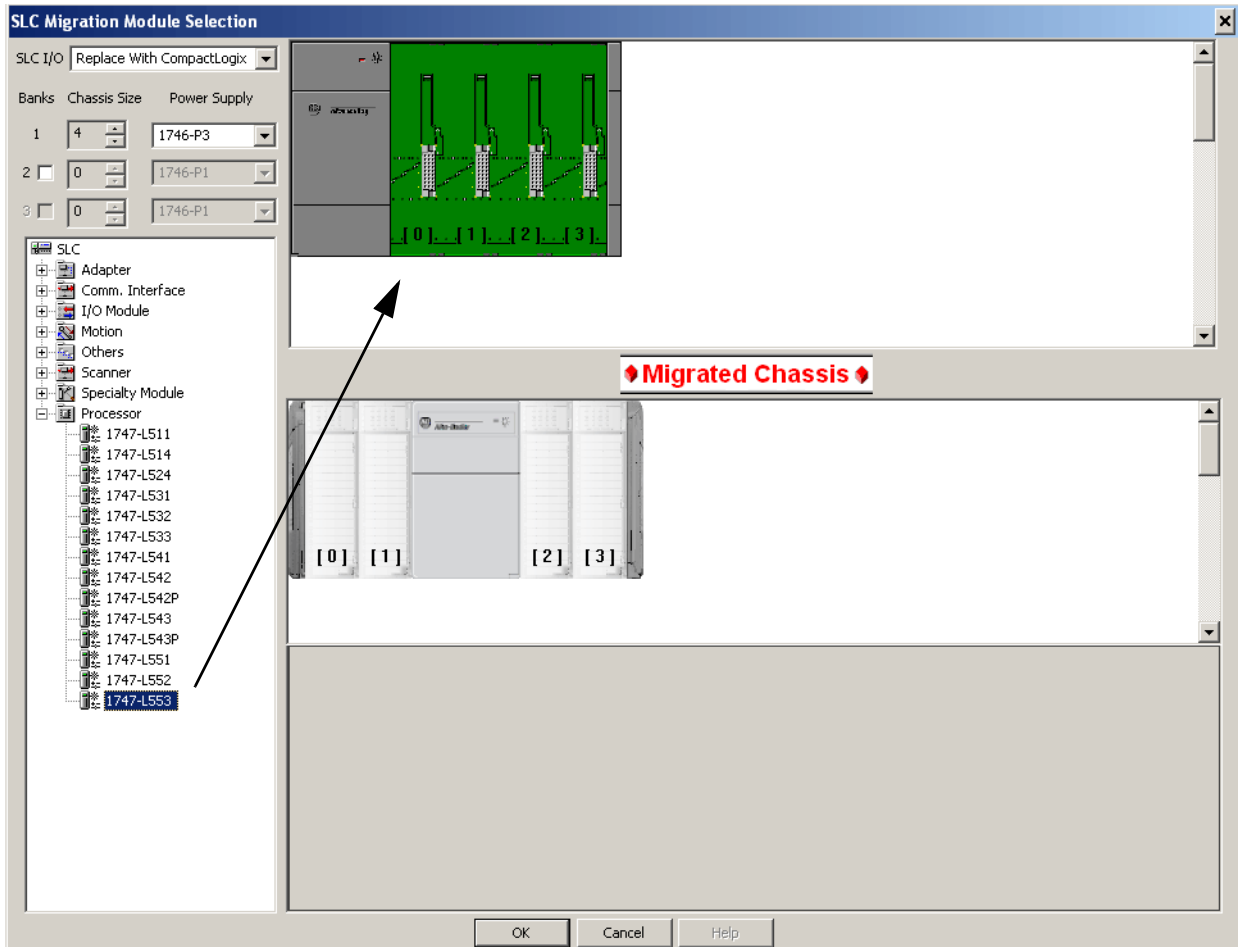

Because IAB has found more than one possible CompactLogix controller migration option, the SLC Migration Conflict Resolution Dialog box appears.

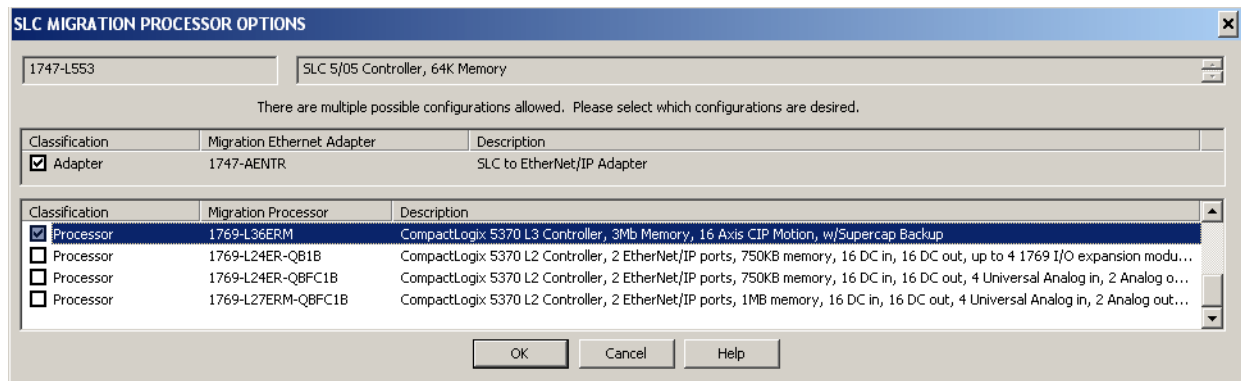

TIP Conflict resolution dialog boxes appear when you must make a decision about the conversion. The information in the dialog box is specific to the action you are performing. In this case, we must select the CompactLogix processor that we wish to use.

- Select a processor in the list and click OK.

In this example, we show the 1769-L36ERM module.

IAB adds processors to both the SLC chassis and the replacement CompactLogix chassis. Additionally, IAB also adds a 1747-AENTR Ethernet adapter module to the retained I/O SLC chassis at the bottom of the display.

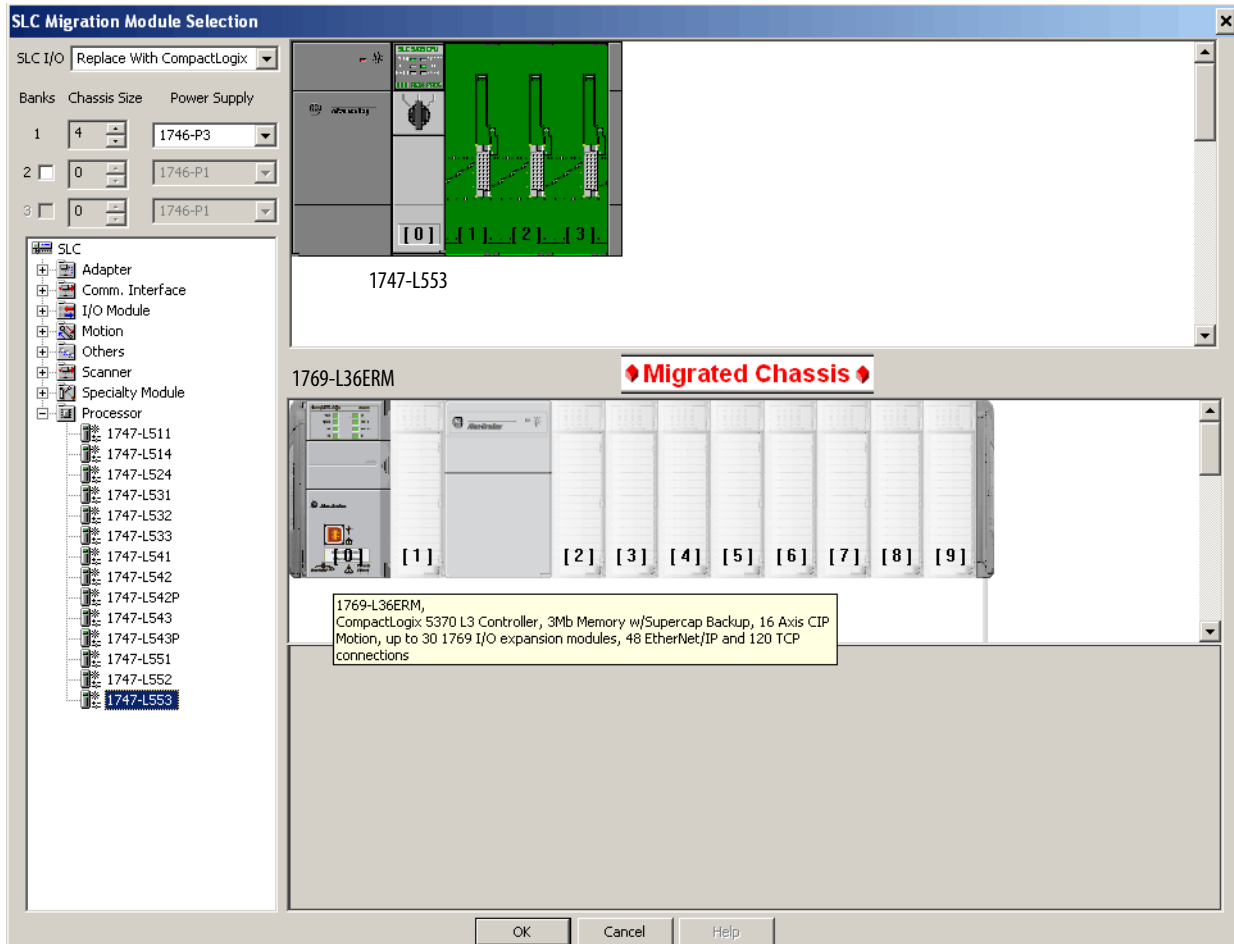

- Repeat steps 8 and 9 to fill remaining slots.

TIP If you incorrectly place a module, right-click the module and click Remove Module to try again.

The majority of 1746 and 1747 discrete, analog, and specialty modules are compatible with the 1747-AENTR adapter.

For a list of supported and unsupported modules, see [I/O Modules on page 69](#).

If you have a module that is not compatible, the following warning occurs.

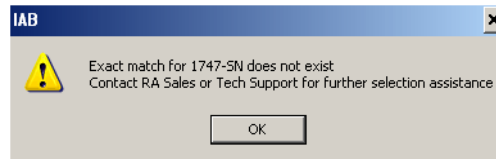

IMPORTANT Modules not supported as part of a retained I/O solution, when connected to a Logix controller, are not placed into the lower chassis in IAB.

11. Once the local SLC chassis is complete, click OK.
12. In the SLC Migration Chassis Selection dialog box, click Generate Hardware to create the wizard-defined CompactLogix configuration in IAB.

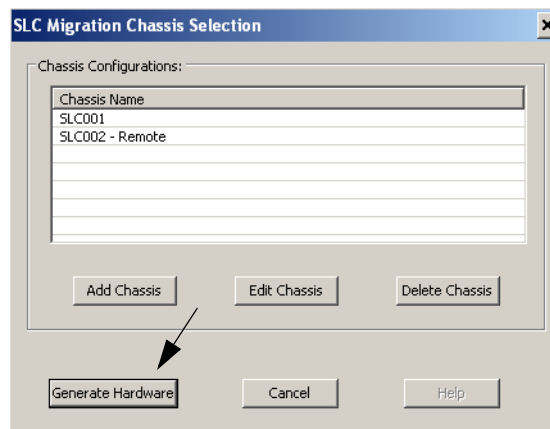

- Click the Hardware tab  in the lower left corner of the IAB window and click the chassis to see the hardware.

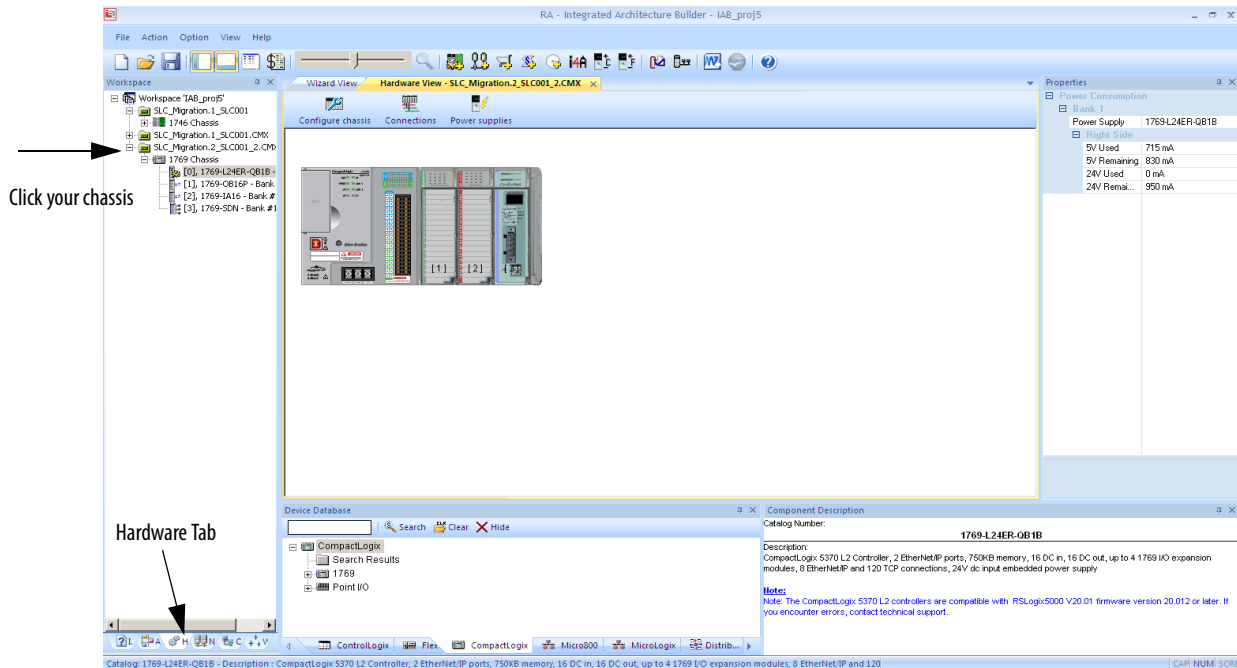

This chassis contains all of the SLC I/O from the local rack that was replaced.

- Click the save icon to save your project.

Adding a Chassis

If your system does contain additional remote chassis, you can add to the existing chassis.

- On the SLC Migration Chassis Selection dialog box, click Add Chassis.

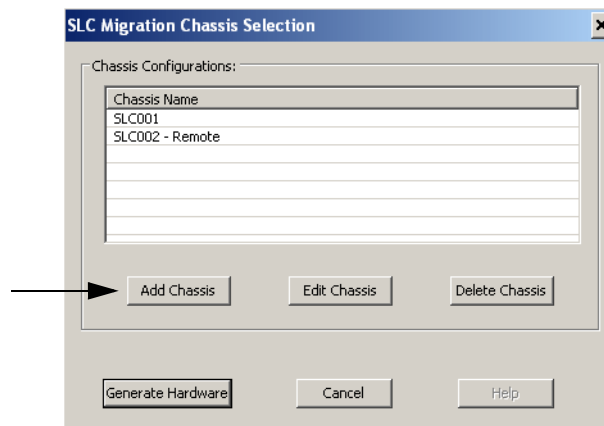

This chassis replaces the remote SLC I/O chassis in your existing system.

- Name this chassis, for example, SLC002_Remote, and click OK.

3. Select the chassis and power supply.
4. Choose to retain the SLC I/O for this chassis.

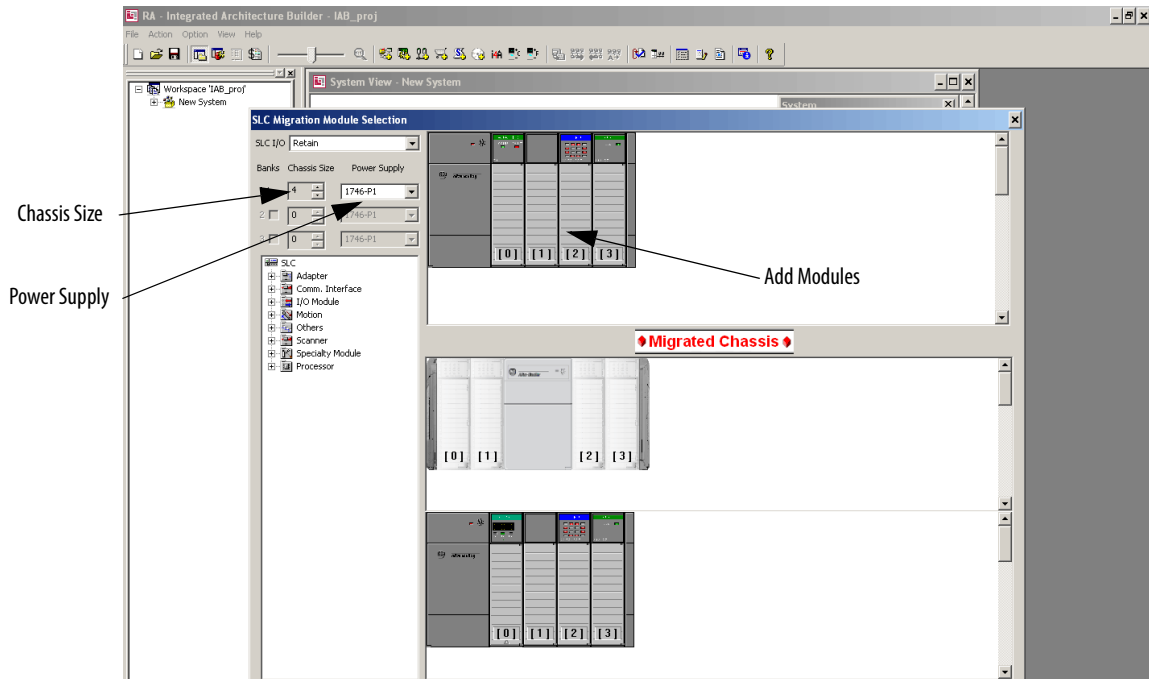

5. Add your remote I/O adapter module to slot 0 of the SLC chassis.

IMPORTANT IAB replaces the 1747-ASB adapter with a 1747-AENTR Ethernet adapter in the replacement SLC remote I/O chassis.

6. Add in the rest of your I/O modules.

TIP If you incorrectly place a module, simply right-click the module and click Remove Module to try again.

The majority of 1746 and 1747 discrete, analog, and specialty modules are compatible with the 1747-AENTR adapter.

For a list of supported and unsupported modules, see [I/O Modules on page 69](#).

If you have a module that is not compatible, the following warning occurs.

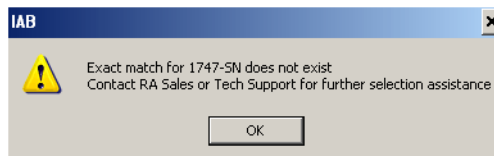

IMPORTANT Modules not supported as part of a retained I/O solution, when connected to a Logix controller, are not placed into the lower chassis in IAB.

7. Once the remote SLC chassis is complete, click OK.

8. In the SLC Migration Chassis Selection dialog box, click Generate Hardware to create the wizard-defined CompactLogix configuration in IAB.

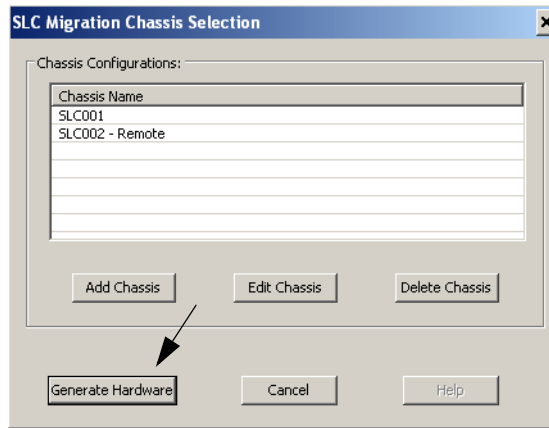

9. Click the Hardware tab  in the lower left corner of the IAB window.
10. Click on the SLC_Migration.1_SLC002 - Remote chassis to see the hardware.

This chassis contains all of the SLC I/O from the remote rack that you replaced. A 1747-AENTR module has been added to connect this I/O remotely over Ethernet to the CompactLogix controller that is replacing our SLC processor.

11. Click the save icon to save your project.

You have three options when converting the second, remote chassis:

- To convert the local SLC I/O, leave the remote SLC chassis in place, add the Ethernet wiring, and rebuild the BOM.
- Add the I/O modules from the second SLC chassis to the new local CompactLogix system.
- Swap out the remote SLC I/O chassis with a more cost-effective FLEX™ or POINT I/O system.

In either case, this is best done outside the wizard.

Network Connection Options for the Remote (SLC System) I/O Chassis

Connecting I/O systems to a controller is best accomplished by first creating a network connection on the controller itself. Because the remote SLC I/O chassis is configured with a 1747-AENTR Ethernet adapter you can connect it to the CompactLogix chassis by using an Ethernet network.

1. In the Hardware View for the SLC_Migration_SLC001.CpLX chassis, right-click the controller and choose **Connect > Connect 'Port 1' to a new EtherNet/IP Network > Standalone Device Level Linear**.

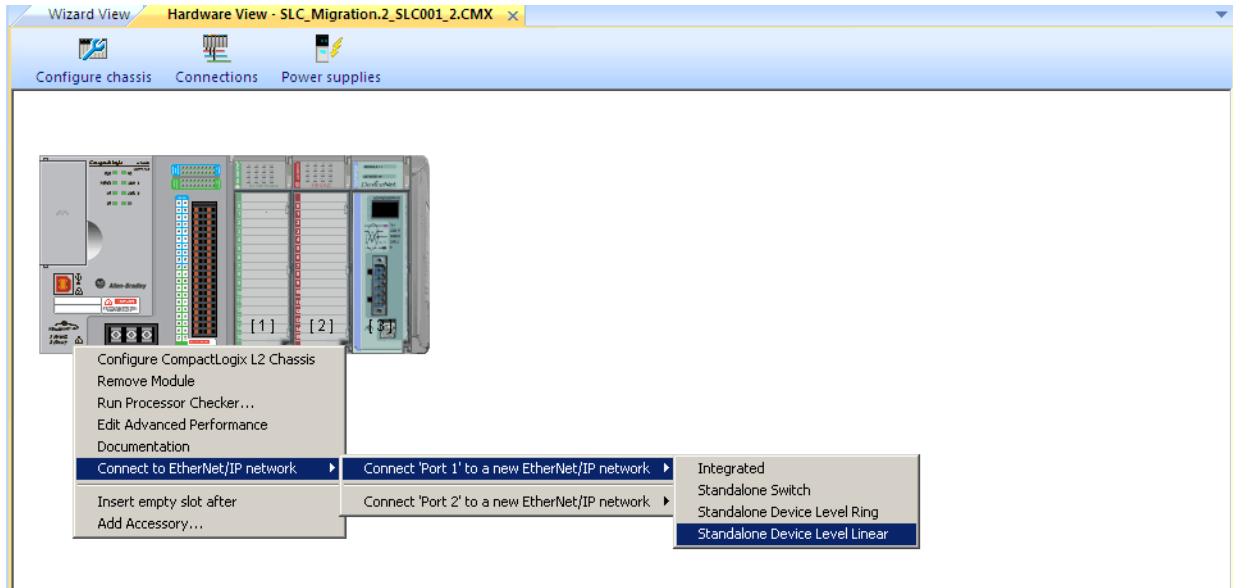

2. Click OK to accept the default network name.

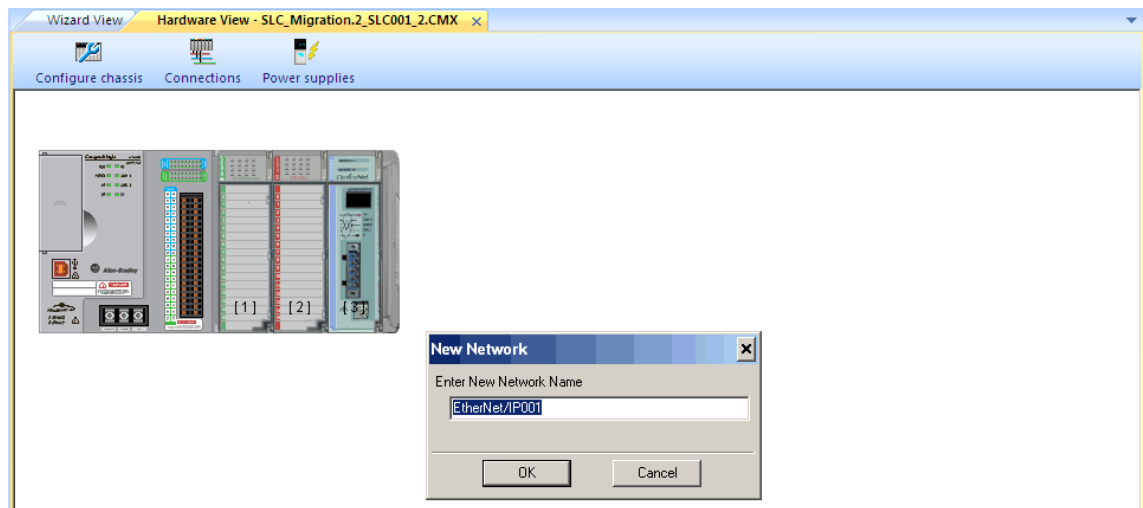

3. Click OK to choose default Copper media for the linear topology.

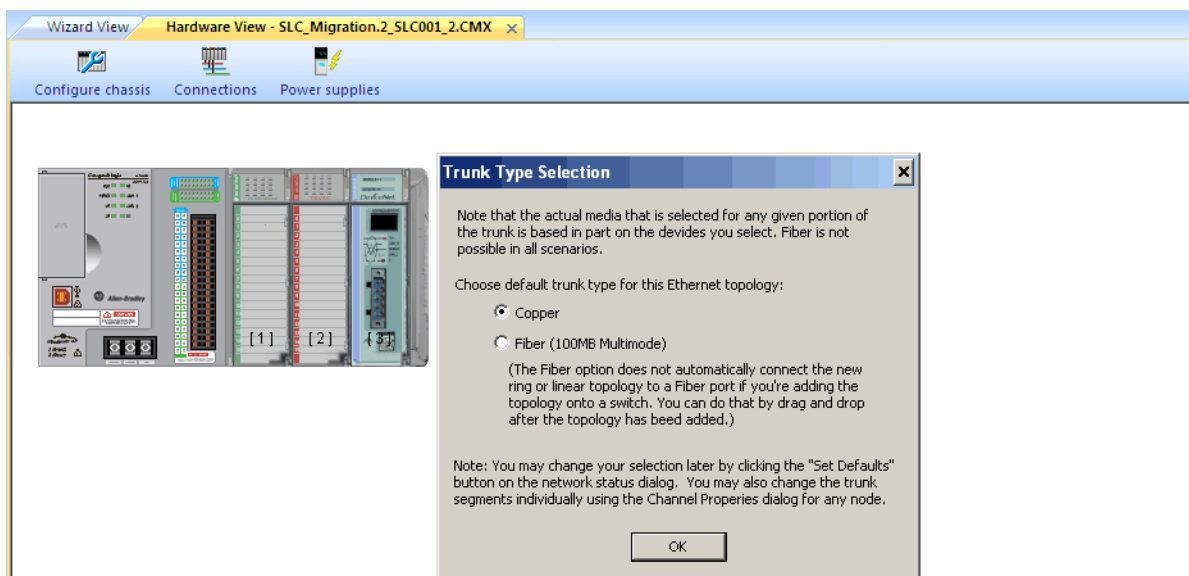

4. Set the IP address (reference only) of the CompactLogix controller and click OK.

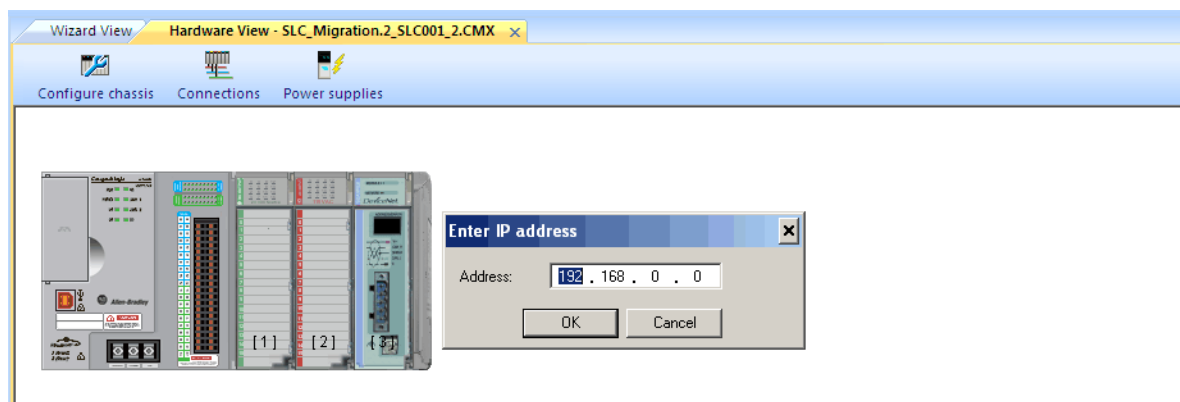

IAB indicates that new connections on this Ethernet network is connected to the CompactLogix controller.

5. Click OK.
6. Choose the Network tab.

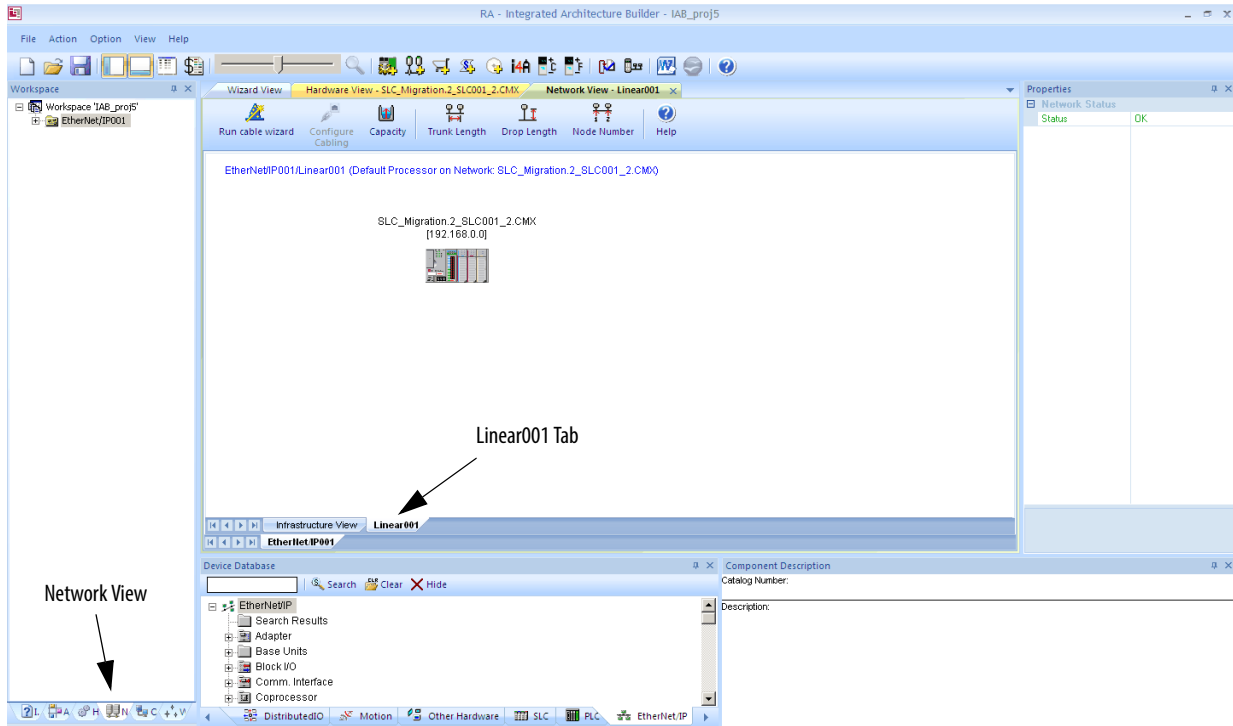

7. In the Network View, choose the Linear001 tab.

You see an icon representing the CompactLogix controller. You add your remote I/O devices in this view.

8. Select an I/O adapter from the Ethernet device list tab and drag it into the Network View window.

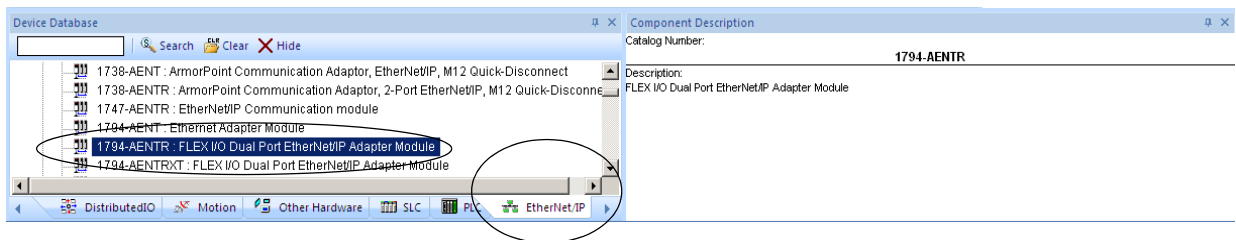

In this example we use the 1794-AENTR adapter module.

You can modify the characteristics of the adapter such as its IP address.

9. Right-click the FLEX adapter and choose Channel properties.

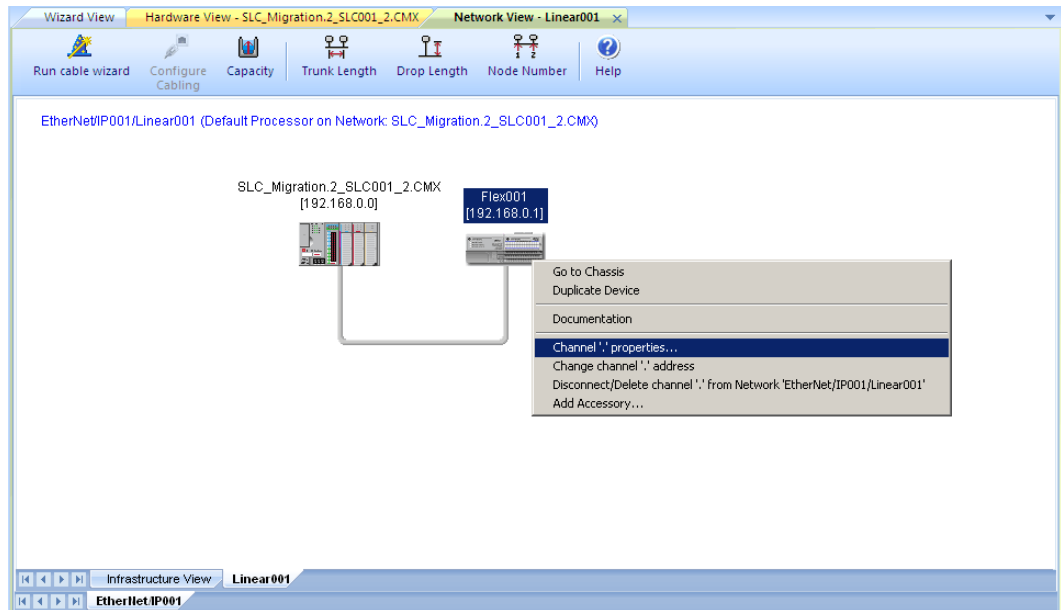

10. Configure the IP address of the FLEX adapter and click OK.

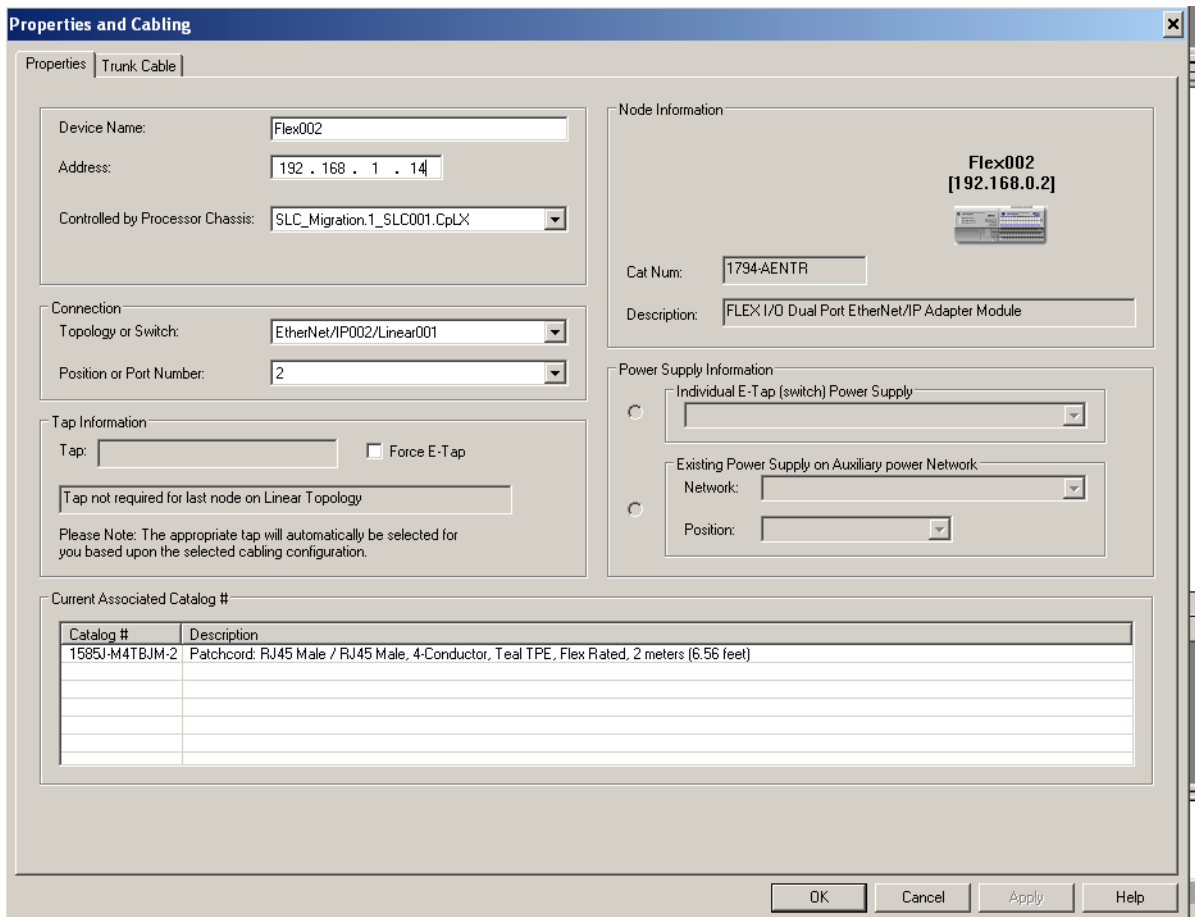

11. Add the I/O modules to this FLEX chassis.

If you need to expand the chassis size to accommodate your needs, follow these steps.

- a. Right-click the Flex001 adapter and choose Goto Chassis to reveal the FLEX adapter in the Hardware View.
- b. Right-click the FLEX adapter and choose Configure Chassis.

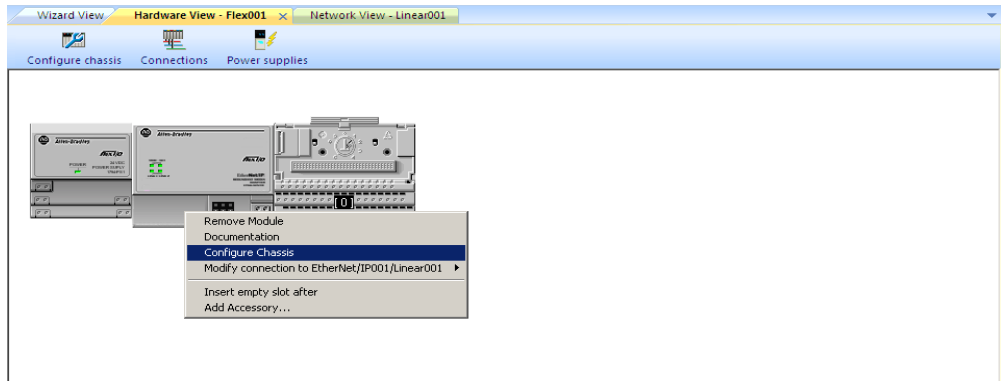

c. Set the value for the Number of Slots and click OK.

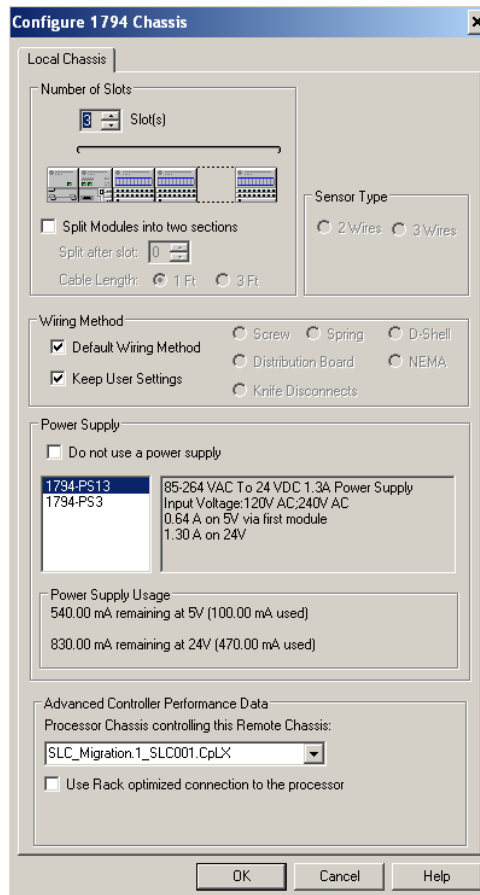

12. Save your project.

Create Project Bill of Material

Follow these steps to get an idea of how much your conversion is going to cost and what is needed.

1. From the Menu Bar, click the Project Bill of Material (BOM) icon.

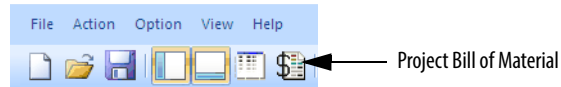

From this dialog box, we can get a clear view of the material necessary to make the conversion based on the chassis layouts.

Qty	Catalog #	Description	Unit Price	Price
Hardware				
SLC_Migration_1_SLC001				
001	1747-AENTR	EtherNet/IP Communication module	2050.00	2050.00
			Subtotal:	2050.00
SLC_Migration_1_SLC001.CpLX				
001	1769-ECR	Right End Cap Terminator	34.50	34.50
001	1769-L36ERM	CompactLogix 5370 L3 Controller, 3Mb Memory w/Supercap Backup, 16 Axis CIP Motion, up to 30 1769 I/O expansion modules, 48 EtherNet/IP a...	4500.00	4500.00
001	1769-PA2	120/240V AC Power Supply (5V @ 2.Amp)	277.00	277.00
			Subtotal:	4811.50
SLC_Migration_1_SLC002 - Remote				
001	1747-AENTR	EtherNet/IP Communication module	2050.00	2050.00
			Subtotal:	2050.00
			Total:	8911.50
The pricing provided is List Price. Please consult your local sales person to get your specific pricing.				

Show all slot numbers

Organized BOM
 Consolidated BOM
 Positional BOM

In addition, the radio buttons along the bottom of the dialog box let you manipulate the information either as a consolidated spreadsheet or by slot location. All of these arrangements incorporate pricing either with List or Custom pricing models.

2. Click Close to close the BOM window.

Notes:

Conversion

Introduction

The Logix Designer application includes a translation tool that converts an SLC 500 import/export file (SLC extension) into a complete import/export file (L5K extension) for the Logix Designer application.

TIP The Studio 5000 environment, which includes the Logix Designer application, was introduced in version 21. If you are using RSLogix 5000 software version 20, the steps are nearly identical.

This section describes the translation tool, Translate PLC-5/SLC 2.0, that comes with RSLogix 5000 programming software version 19 and later (Logix Designer application version 21 and later). This section also describes pre-translation file preparation and post-translation examples and tasks.

The translation tool can also be downloaded from the Rockwell Automation Knowledgebase within Answer ID 69790.

http://rockwellautomation.custhelp.com/app/answers/detail/a_id/6979

For a more detailed explanation of the translation tool, refer to Converting PLC-5 or SLC 500 Logic to Logix-based Logic, publication [1756-RM085](#).

IMPORTANT The process for converting an SLC system to a ControlLogix system is similar to converting to a CompactLogix system.

What to Expect from the Translation Tool

The goal of the translation tool is to reduce the amount of work involved in migrating an SLC 500 program to a Logix project. The translation tool automatically converts the program logic, but the tool is not the complete solution. Depending on the application, you may need to do additional work to make the converted logic work properly.

The translation tool produces a syntactically correct import/export file, but the exact intent of the original application could be lost. This loss could be due to differences in rules. (For example, rules of precedence, rules of indexed addressing, or rules of I/O addressing). When there is an error in the translation, the translation tool records the error in the rung of the Logix routine in which it occurred. You can use that error message to analyze and fix the error.



ATTENTION: After running the conversion process, the resulting import/export file still requires further manipulation. You have to map the I/O and use BT, MOV, or CPS instructions to place this mapped data into the structures created by the conversion process.

Application Code Conversion

The first step in a procedure of this type is to export the current SLC project into an ASCII text format.

1. From the desktop, double-click the RSLogix 500 programming software icon.



Or, choose Start > All Programs > Rockwell Software > RSLogix 500 > RSLogix 500.

2. From the File menu, choose Open to open the file you want to convert.

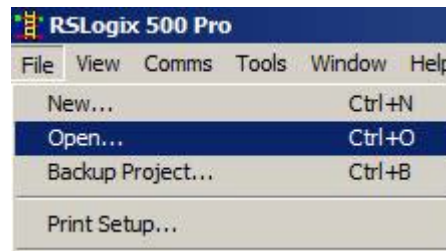

The first step is to export the current SLC project into an ASCII text format.

3. From the File menu, choose Save As.

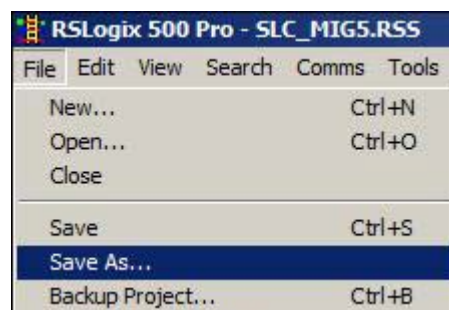

4. Browse to the folder where you are saving the converted program.

5. Check Export Database and click A.P.S. to select this format.

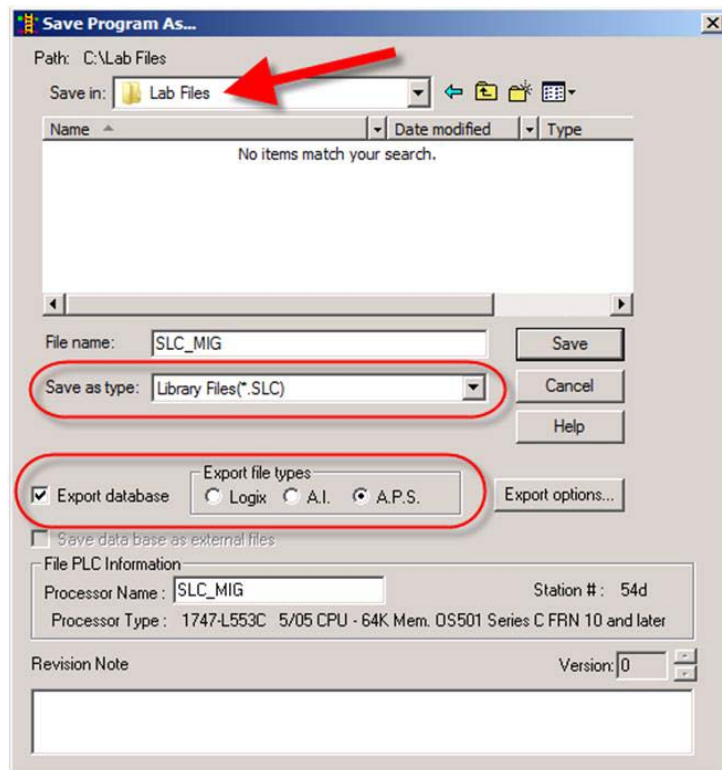

6. Set the file type to '.SLC'.

TIP When you change the file type to .SLC, the export database section becomes grayed out, which is fine as long as the export database is set to A.P.S.

The translation tool accepts projects that have been exported a .SLC file type.

IMPORTANT The database for these projects must also be exported for proper import into the Logix Designer (RSLogix 5000) translation tool. With this release of the translation tool, rung comments, address comments, and symbols must be exposed by using the Advanced Programming Software (APS) text format.

7. Click Save to continue.

Additional file export options are presented. For this example, we want to export the entire project, so the default settings here are fine.

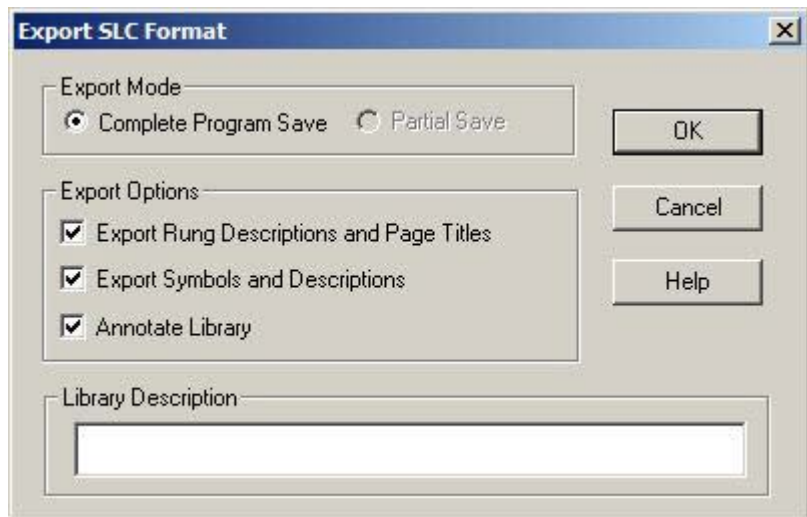

8. Click OK.

IMPORTANT This warning appears to indicate that some comments and symbols are truncated, which can lead to some duplication of database information. This is worth noting, especially if you want to edit the resulting text files before executing the translation.

9. Click OK.

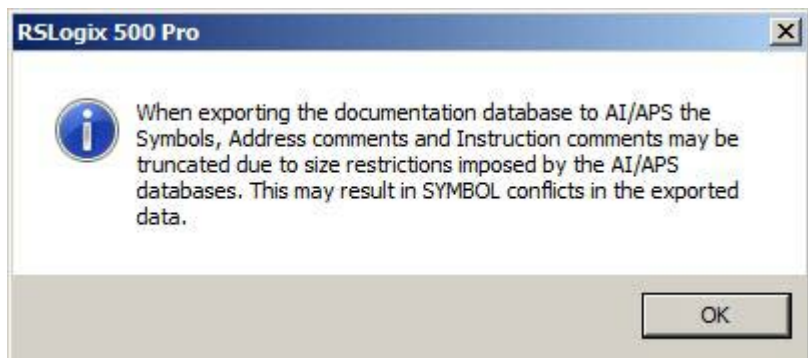

When the export has completed, the Export Results dialog box appears.

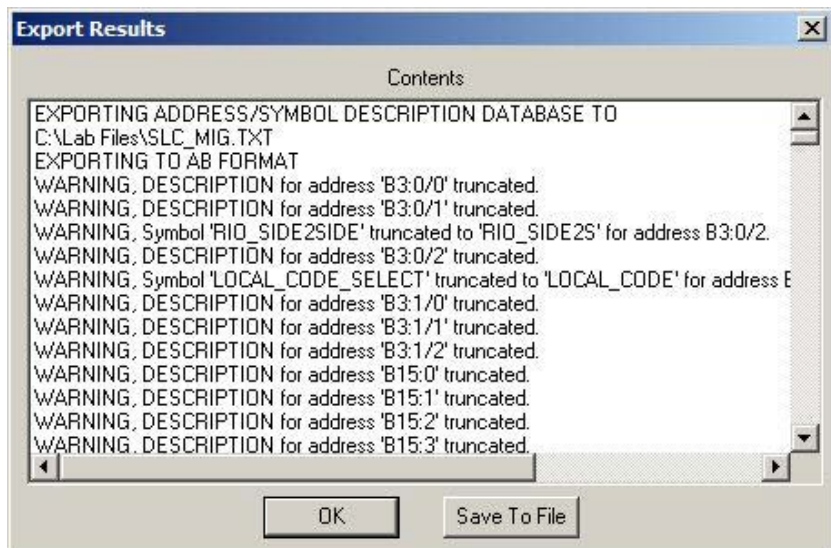

TIP You can scroll through the list of warnings that appear. You can also save the results to a file for reference when finalizing the code translation later.

10. Click OK.
11. Close the RSLogix 500 software.

Translate an RSLogix 500 Program to a Logix Designer Program

The Logix Designer translation tool is an optional install as part of the Logix Designer application installation procedure. Once you have the ASCII text file of the SLC 500 program file, you can convert the logic to its Logix equivalent. In the Logix Designer application, use the following steps.

1. Launch the tool from one of two locations:
 - From the Windows Start Menu: Start > Programs > Rockwell Software > Studio 5000 Tools > Translate PLC-5_SLC 2.0
 - From within the Logix Designer application: Tools > Translate PLC-5_SLC 2.0

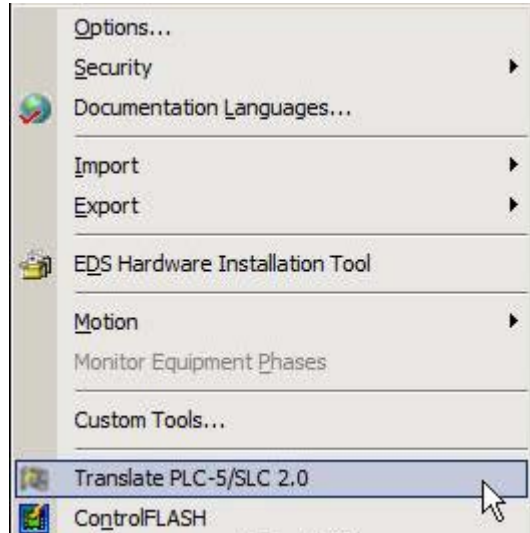

The initial dialog box for the Translation Wizard appears.

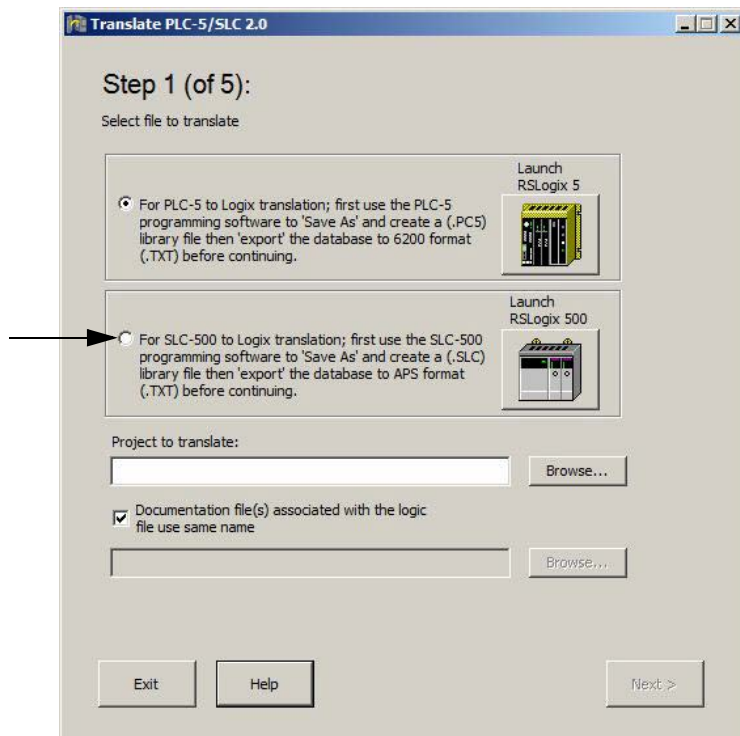

2. Click For SLC-500 to Logix translation.

3. Click Browse and locate .SLC file.
4. Click open.

By default, the wizard expects to use the default documentation file names that you exported earlier.

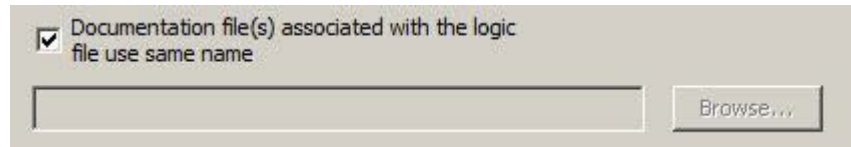

5. Click next.

In the second step of the translation process, you set the options for the new project you are creating. The output file is a text-based .L5K project that can be edited in any text editor if necessary and ultimately opened in the Logix Designer application. The output filename is satisfactory, but you need to select the controller type and version.

6. Use the pull-down menu to select the controller and version number.
For example, 1769-L24E controller with a version of 21.

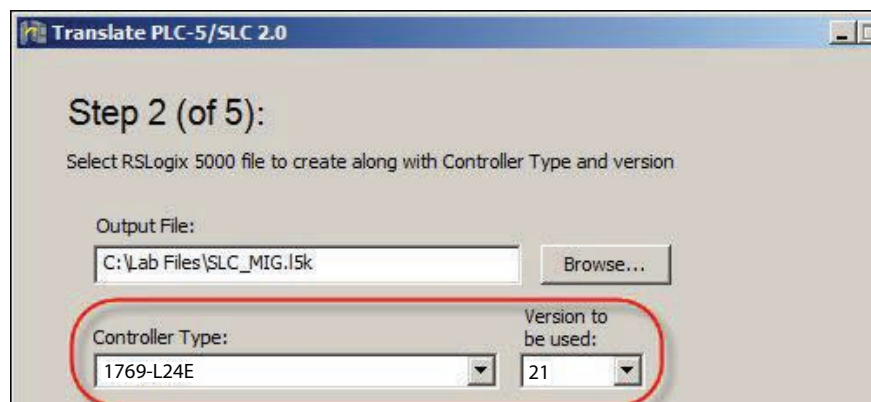

7. Click next.

In the third step of the translation process, the wizard provides you with selections for the creation of I/O and Symbol aliases. The resulting controller alias tags can be useful to users who otherwise have to modify tag names in the program code.

- Create Alias Tag for existing PLC-5/SLC *Physical Addresses*

This option creates alias tags for all I/O file addresses. For example, a PLC-5 address of O:1.7 has an alias tag of O_001_Bit07 created. An SLC address of I1.3/2 has an alias tag of I1_003_Bit02 created. This makes mapping legacy I/O data to the Logix platform easier because the aliases can be modified to point at the new I/O data without a change to the program logic.

- Create Alias Tag for PLC-5/SLC *Symbols*

This options creates alias tags for all symbols found in the database files. If this option is not selected, the symbols are added as tag comments to the converted legacy types.

TIP Details on how each of these settings affects the output project can be found by clicking the help button and scrolling down to the Translation Options section.

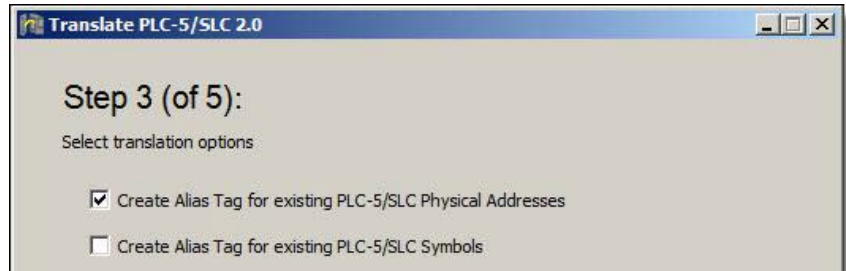

8. Click Translate.

If there are any syntax errors during translation, the Syntax Error dialog box appears, showing the line in which the syntax error occurred.

9. Resolve any syntax errors by using any of the following actions:

- Edit the error immediately at this dialog box and then click Save & Retry to restart the translation.
- Examine the original application to decide if the area where the syntax error is occurring is something that can be deleted permanently or if it is something that can be removed and then later be recreated in the Logix Designer application.
- Edit the SLC and TXT files by using Notepad.
- Review this table for the most common syntax errors and their descriptions.

The translation tool can run into syntax errors within the program and database files. If so, you must correct those errors so that the translation tool can continue the conversion. [Table 1](#) shows the more common errors.

Table 1 - Common Conversion Errors

Syntax Error	Description	How to Fix the Error
Invalid symbol name	The translation tool expects the symbol names to be alphanumeric. RSLogix 500 software enforces these rules, but using 6200 software or manually editing the database files can cause these rules to be broken.	Search for symbol names that are not alphanumeric.
" (quote) within a " (quote)	Quotes are used to denote the start and end of string values or rung/instruction/address comments. If a rung/instruction/address comment contains a quote, the translation tool doesn't know that it isn't the end of the string.	Either remove the quote or make it a double quote (""). The translation tool translates the double quote as a single quote within the Logix Designer application.
% within a %	% characters are used to denote the start and end of comments within the program file and occasionally in database files. This type of comment is ignored by the translation tool. If a comment contains another %, the translation tool doesn't know that it isn't the end of the comment.	Remove the extra % or make it a double %. The translation tool treats the double %% as consecutive comments.
Errant characters	The program or database file contains a random character or two that does not fit the syntax of the program or database files. This is more common with manually-edited files than a direct export from RSLogix 500 software.	Remove the errant characters.
Invalid rung syntax	The rung has invalid syntax, such as unmatched parentheses.	Check and fix the rung syntax.

10. Once these errors have been resolved, click Save & Retry.

The translation is completed as shown below.

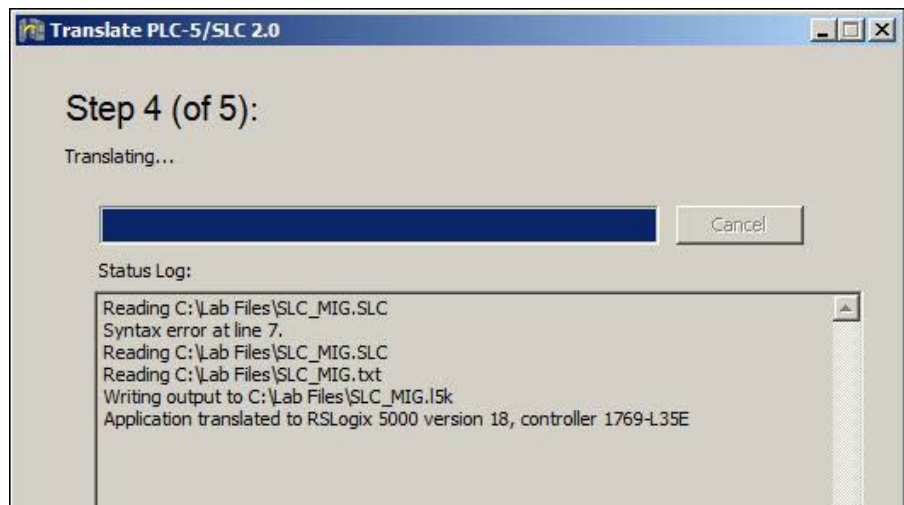

11. Click Launch RSLogix 5000 in the lower right corner of the dialog box.

12. Browse to find the folder and click Import.

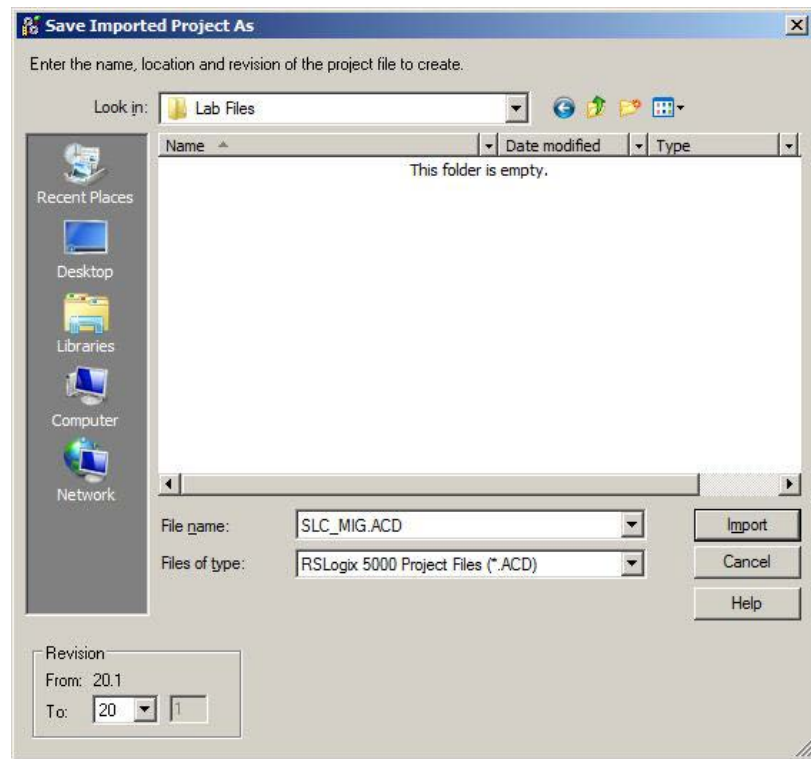

The file is being imported into the Logix Designer application automatically.

Once the files have finished importing, the Logix Designer application opens and the bottom of the dialog box displays the results. Double-click the errors in the results window to locate the PCE (Program Conversion Error) messages that the translation tool inserted within the rungs.

Resolve the Differences in the New Logix Program

Now that the SLC 500 program has been initially converted to a Logix program, you need to look at some of the most common elements that must be addressed for the CompactLogix project to properly control the installed 1746 I/O modules.

TIP See [Appendix B](#) for supported and unsupported I/O modules.

SLC Controllers Data Tables and Logix Controller Tags

The SLC 500 processors store all data in global data tables. You access this data by specifying the address of the data you want. A Logix controller supports data that is local to a program and data that is global to all the tasks within the controller. A Logix controller can also share data with other controllers, and instead of addresses, you use tags to access the data you want. Each SLC 500 data table file can store several words of related data. A Logix controller uses arrays to store related data. The translation tool converts the SLC 500 data table files into Logix arrays.

With a Logix controller, you use a tag (alphanumeric name) to address data (variables). The controller uses the tag name internally and does not need to cross-reference a physical address.

- In conventional programmable controllers, a physical address identifies each item of data.
 - Addresses follow a fixed, numeric format that depends on the type of data, such as N7:8, F8:3.
 - Symbols are required to make logic easier to interpret.
- In Logix controllers, there is no fixed, numeric format. The tag name itself identifies the data.
 - Organize your data to mirror your machinery.
 - Document (through tag names) your application as you develop it.

Resolve Program Code Issues

The translation tool inserts a Program Conversion Error (PCE) instruction within the appropriate ladder rung to help you identify possible errors with the conversion. To complete the conversion process, you want to locate, analyze, and fix any discrepancies involving the PCE instructions.

TIP For a complete list of the PCE instruction Message IDs and their descriptions, please refer to [Appendix A](#).

IMPORTANT After the correction of any errors, you must still spend time running and debugging the machine or process.

Locating PCE Instructions

You can locate all of the PCE instructions by verifying the logic. The Verify>Controller task compiles the Logix program and checks for errors. This is an easy way to see where all of the PCE instructions are because the error checking points them out. To locate the PCE instructions, use the following steps.

1. From the Logic menu, choose Verify> Controller.

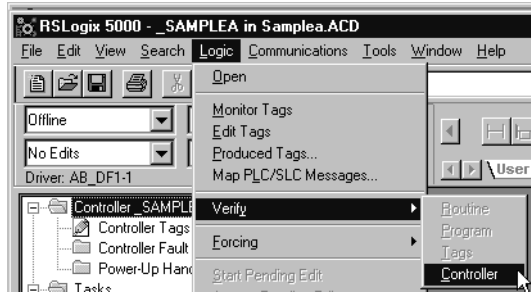

Or, from the menu bar, choose the Verify Routine icon.



The bottom of the dialog box displays results.

2. Double-click the error shown in the error window to go directly to the rung where the error occurred.

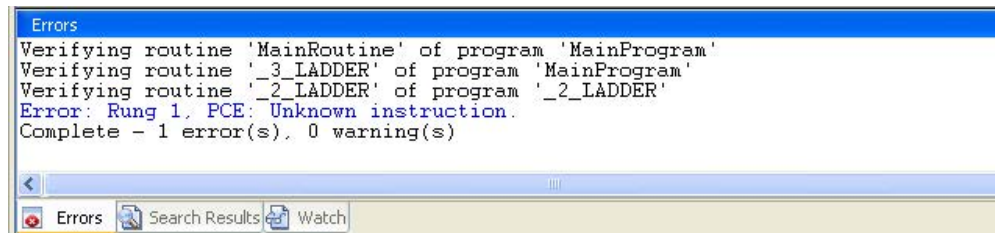

TIP Some Warnings reference bits that are used as outputs in more than one rung, Duplicate Destructive Bits. While using this type of coding is generally not recommended, with careful programming, using the same outputs on several different rungs can be done.

Recognizing the Instructions

Text is appended to the rung comments that have the PCE instruction. The message text begins with asterisks(*) and the words “Generated by Translation Tool”, and ends with asterisks.

An example of a PCE instruction follows:

```
*** Generated by Translation Tool: Source and destination types may differ *** ;
```

```
N: PCE(120, PCE011) COP(I1_008, N23[0], 4);
```

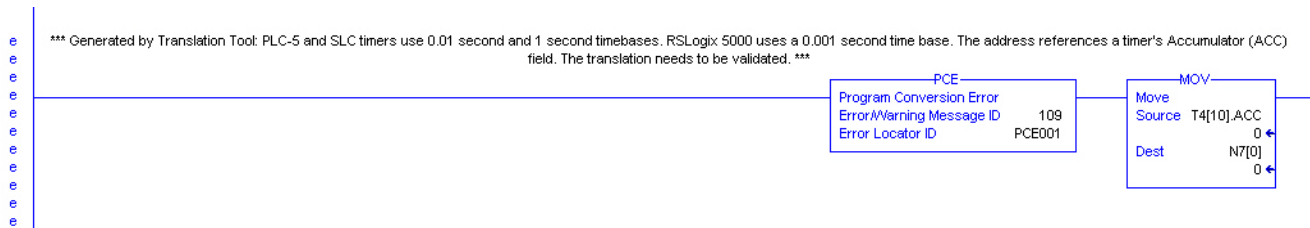

Resolving PCE Instructions

Once you import the converted Logix project, find each PCE instruction. A PCE instruction highlights a possible conversion error. Delete each PCE instruction and replace it with the appropriate, corrected logic.

Common PCE Issues

Translation greatly reduces the amount of work in a conversion; however, you may still get conversion errors that must be addressed individually.

- A very common error occurs with all Timer related instructions. The timer instruction and its associated elements are compatible between the SLC 500 controller and the Logix platform. However, the SLC 500 controller supports only a .01 or 1 second time base for timers. Logix controllers support a 1 ms time base. The code conversion resulted in an increase of the timer Preset value by an order of magnitude. That is, the original Preset in the SLC 500 controller for this timer was 32767 and now it has been changed to 327670. All related references to this timer have been adjusted automatically, except those that reference a specific bit within the Accum or Preset itself. This can lead to errors on any rung that addresses a Timer.PRE or Timer.ACC because the scaling can be off and can be corrected only by user intervention.
- Another common conversion tool error is related to MSG instructions. Not all SLC 500 MSG instructions convert completely and, after the conversion, you need to verify that the data and path in all MSG instructions are correct.
- Several other SLC instructions may not convert properly or may not have the intended behavior. Among the more significant SLC instructions that can have issues are serial port instructions, Block Transfer instructions, FBC, and PID.

Map PLC/SLC Messages

Map PLC/SLC Messages is a built-in feature of Logix controllers that lets older products that support a data table memory architecture, like PLC-2, PLC-5, and SLC controllers read/write to a Logix controller that has a tag-based memory architecture.

If after the conversion, legacy SLC controllers need to communicate to the converted Logix controller, Map PLC/SLC Messages can facilitate this. See the example below for an overview explaining PLC/SLC Mapping.

EXAMPLE If an incoming message from an SLC controller requests to read data from file N7:x, the Logix controller replies with data from tag SLC_Reads_This_LogixTag[x].

If an incoming message from an SLC controller requests to write data to file N10:x, the Logix controller places that data in tag SLC_Writes_to_This_LogixTag[x].

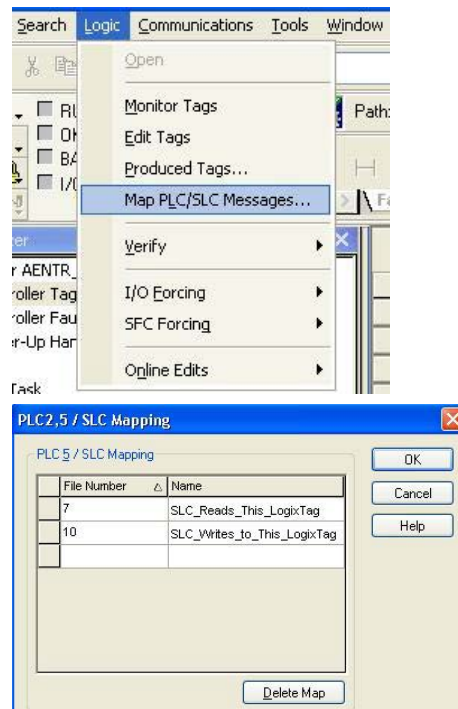

Resolving Issues with Physical I/O

Remember, in your new CompactLogix system, all of the 1746 I/O is considered remote, but you are not using remote I/O. Each SLC chassis is connected through the 1747-AENTR Ethernet adapters. This eliminates quite a bit of extra code otherwise required to communicate to remote I/O.

There are three options for resolving physical I/O issues:

- MOV instructions
- CPS instructions
- Aliasing instructions

Each has its advantages and drawbacks depending on the type of data. Ideally, the translation tool identifies I/O to be converted and offers you options during the conversion process rather than leaving this to you afterwards.

These examples illustrate situations you can encounter when translating your files.

MOV Example

This first rung is used to initialize the configuration for a 1746-NT4 module in slot 5 of the local SLC 500 chassis.

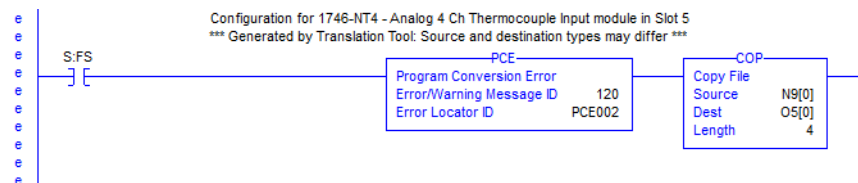

The Dest data location represents an integer array of at least 4 elements. To successfully configure multiple channels, the normally consecutive array elements must be transferred into non-consecutive structures built by the 1746-NT4 module data type.

The original rung can remain, but you need to create a new rung that moves the configuration for the channel to the corresponding module config tag.

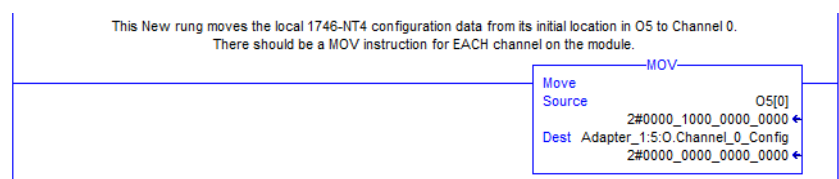

This resolves the issue for Channel 0. Additional MOV instructions are required if other channels are used.

CPS Example

In RSLogix 500 software in order for many specialty modules to transfer data over RIO, sophisticated instructions called Block Transfers were used. In the Logix Designer application, these Block Transfers were replaced with the MSG instructions shown below.

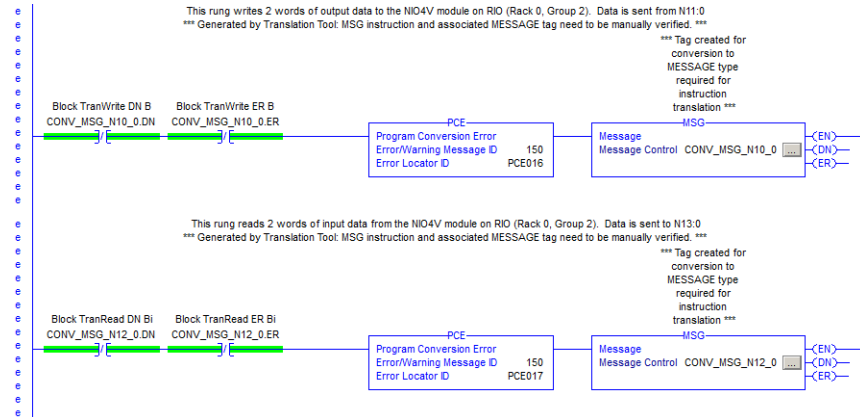

The need for messaging to/from these modules is no longer needed because the controller is communicating with them directly through the 1747-AENTR module.

Figure 3 - Original RSLogix 500 Software Block Transfer Instructions

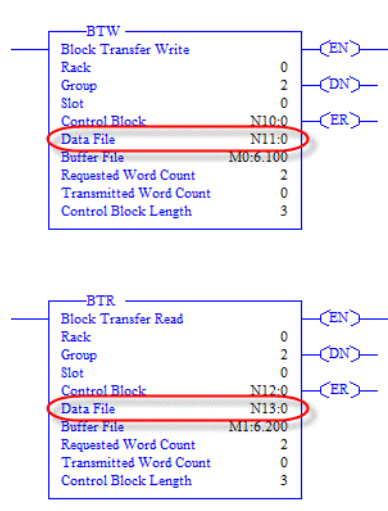

- Data to be written to the remote module in our example, was entered into N11:0 (2 words).
- Data to be read from the remote module into the controller was placed into N13:0 (2 words).

If consecutive I/O groups map to consecutive elements in an array, a CPS instruction must be used. Use a CPS instruction when you copy I/O or Produced/Consumed peer data of more than one DINT. This is the only information you need to create the instructions necessary to replicate the original program functionality.

IMPORTANT Extensive use of the CPS instruction can lock the tag database which could affect other processes.

You can delete the rungs containing the PCE and MSG instructions and replace them with CPS rungs.

The CPS instruction moves data from the array titled N11, which is used throughout the program, to the 1747-I/O module.

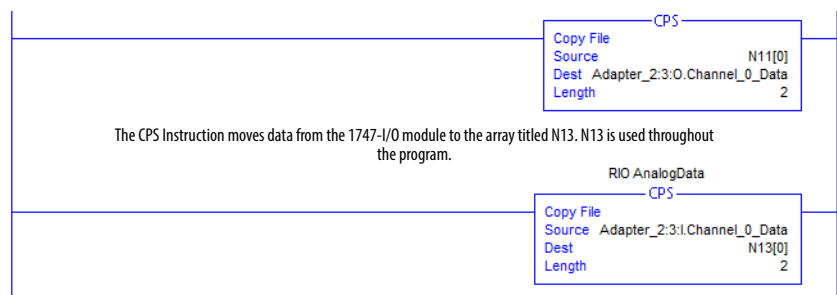

IMPORTANT The CPS instruction is intended to be used when copying I/O data or Produced/Consumed peer data to/from controller tags. For more information on the use of the CPS instruction, see Knowledgebase document KB ID 50235, contact your local Allen-Bradley distributor, or Rockwell Automation sales representative.

Alias Example

The rung in this routine uses a timer accumulator to simulate an analog output value for a 1746 I/O module. Although this is not very realistic, it does provide an instance in which aliasing can be most used.

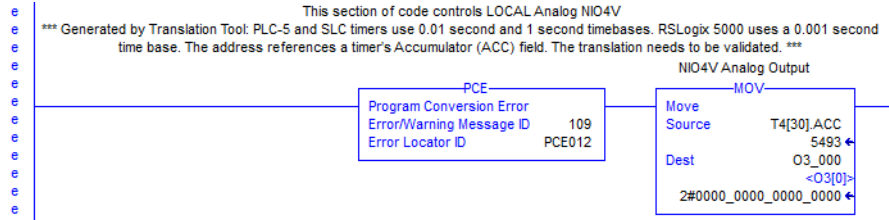

In the example rung, a value is being moved into the O3_000 'alias' tag generated by the translation tool. However, you need to actually tie this tag to a physical output address, namely the output location associated with the 1746 I/O module.

Aliasing the T4[30].ACC to the physical output address can seem like the right choice, but members of an array cannot be aliased in Logix. Because this instruction manipulates just a single word of data, you can modify the MOV instruction. Based on the I/O configuration, the base output data for the local 1746 I/O module is contained in the 'Adapter_1:x:O' tag.

You need to modify the Dest element of the MOV instruction and delete the PCE instruction.

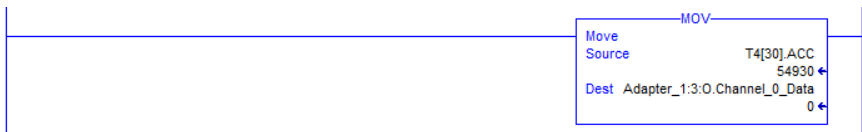

Replace SLC Processor and Adaptors

Mount and wire the CompactLogix system and replace the SLC first slot modules (SLC processor or communication adaptor module) with the SLC Ethernet adaptor, catalog number 1747-AENTR.

Set the Network Address Switches

The network address switches are set to 999 and DHCP enabled, by default. You can set the network Internet Protocol (IP) address in the following ways:

- Use the network address switches on the module.
- Use a Dynamic Host Configuration Protocol (DHCP) server, such as Rockwell Automation BootP/DHCP.
- Retrieve the IP address from nonvolatile memory.

The adapter reads the network address switches first to determine if the switches are set to a valid number. You set the node address by using the network address switches. Valid settings range from 001...254.

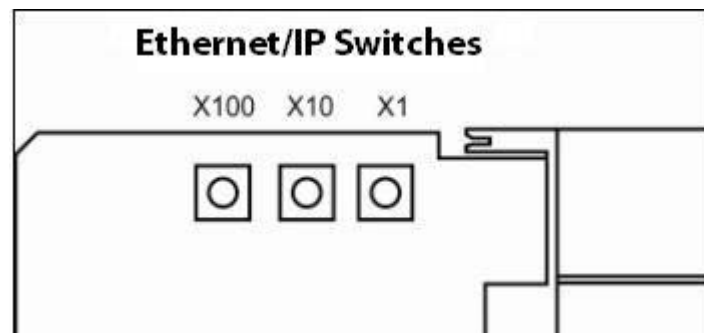

When the switches are set to a valid number, the adapter's IP address is 192.168.1.xxx (where xxx represents the number set on the switches).

The adapter's subnet mask is 255.255.255.0 and the gateway address is set to 0.0.0.0. The adapter does not have a host name assigned, or use any Domain Name System when using the network address switch settings.

If the switches are set to an invalid number (for example, 000 or a value greater than 254 excluding 888), the adapter checks to see if DHCP is enabled. Setting the switches to 888 restores default factory settings.

IMPORTANT

If you set the value of the adapter switch to 888 and then power cycle the module, the following occurs:

- The DHCP Enabled function is enabled (set to True).
- The Ethernet link is negotiated automatically. The Auto Negotiate function is set to True.
- The web server is enabled. The Disabled Web Server function is disabled.
- The Ethernet ports are disabled. Both ports are re-enabled once the switches are returned to their previous value and power is cycled.

DHCP Enabled and Not Enabled

DHCP Enabled and Not Enabled	
If DHCP is	Then the Adapter
Enabled	Asks for an address from a DHCP server. The DHCP server also assigns other Transport Control Protocol (TCP) parameters. The 1747-AENTR factory default is DHCP enabled. When you apply power, the module sends a message containing its hardware address to any DHCP server on the network. The server(s) replies by sending a message with an appropriate IP address for the adapter. The adapter responds by acknowledging to a server that the adapter will use the offered IP address.
Not enabled	Uses the IP address (along with other TCP configurable parameters) stored in nonvolatile memory. When the IP address assigned to the module, as indicated in the four-character dot matrix status display, is changed through the DHCP configuration utility, the DHCP is disabled. When power is cycled to the device, the device uses the new configuration and implements the new IP address.

See the chapter, [Configure the Adapter for Your EtherNet/IP Network](#) on page 11, for information on how to use your BootP/DHCP utility to configure your adapter for the network.

Determine Power Requirements

The Ethernet adapter requires 5V DC with current consumption of 470 mA. The power is supplied through backplane from SLC power supply. Remember to consider this requirement when planning your system configuration.

Install the Adapter Module in the Chassis

After you set the appropriate switch assemblies for your adapter module, follow these procedures for installation.

Refer to the Industrial Controller Wiring and Grounding Guidelines publication [1770-4.1](#) for proper grounding and wiring methods to use when installing your module.

1. Remove power from the I/O chassis before inserting (or removing) the module.

2. Align the circuit board with the chassis card guide in the left slot.

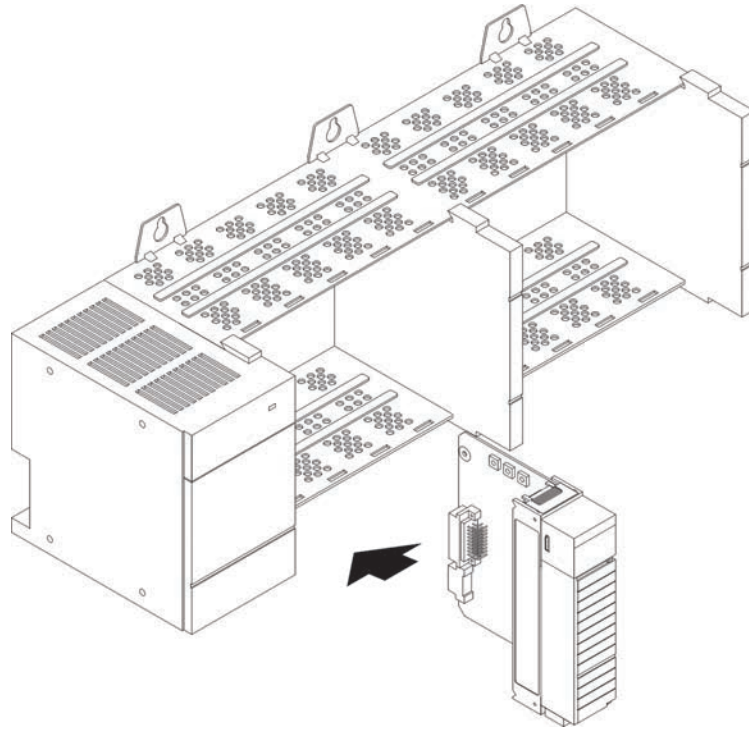

3. Install the module in slot 0 of the chassis by aligning the circuit board with the chassis card guide.

The 1747-AENTR module must be installed only in slot 0 (leftmost slot) of the chassis.

4. Press firmly and evenly to seat the module in its backplane connectors.

To remove the module, press the releases at the top and bottom of the module and pull it out.



ATTENTION: Do not force the module into the backplane connector. If you cannot seat the module with firm pressure, check the alignment. Forcing the module can damage the backplane connector or the module.

Connect Your Adapter to the Ethernet/IP Network through RJ45 Connection

Connect your 1747-AENTR adapter module to an Ethernet/IP network as shown below.

Wire the RJ45 connectors as shown.

	Signal
1	TxData+
2	TxData-
3	Recv Data+
4	Reserved
5	Reserved
6	Recv Data-
7	Reserved
8	Reserved

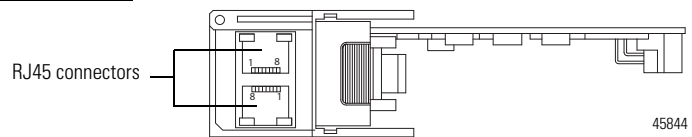
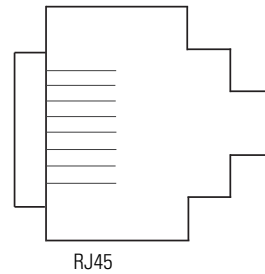

1747-AENTR module bottom view

To connect the module to the network, follow these steps.



WARNING: If you connect or disconnect the communication cable with power applied to this module or any device on the network, an electrical arc can occur. This could cause an explosion in hazardous location installations. Be sure that power is removed or the area is nonhazardous before proceeding.

1. Attach the cables with the RJ45 connectors to the two Ethernet ports on the bottom of the module.

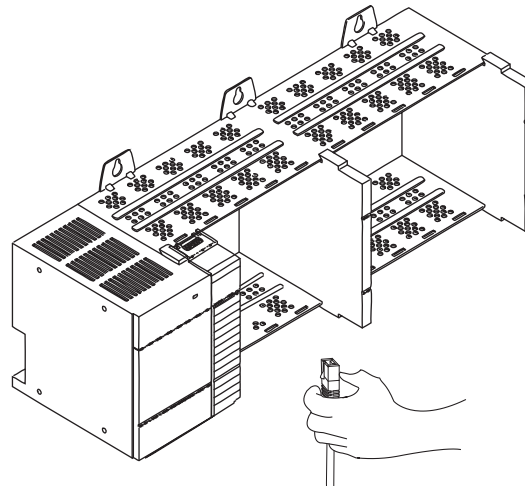

- Attach the other end of the cables to the devices in your network.

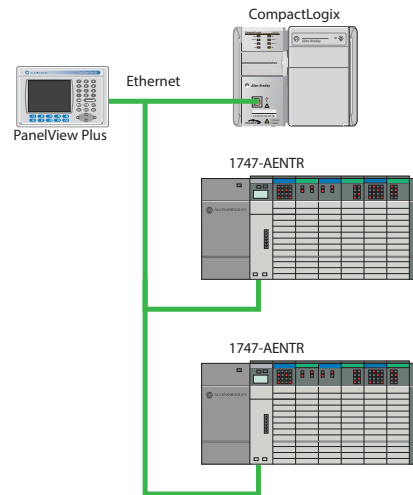

- Configure your 1747-AENTR adapter.

See publication [1747-UM076](#) for information on configuring and using your adapter.

Replace Other Components

If your control system has legacy or competitive operator interface, variable frequency drives, motion control, sensors, or motor control centers, you can migrate those products as well.

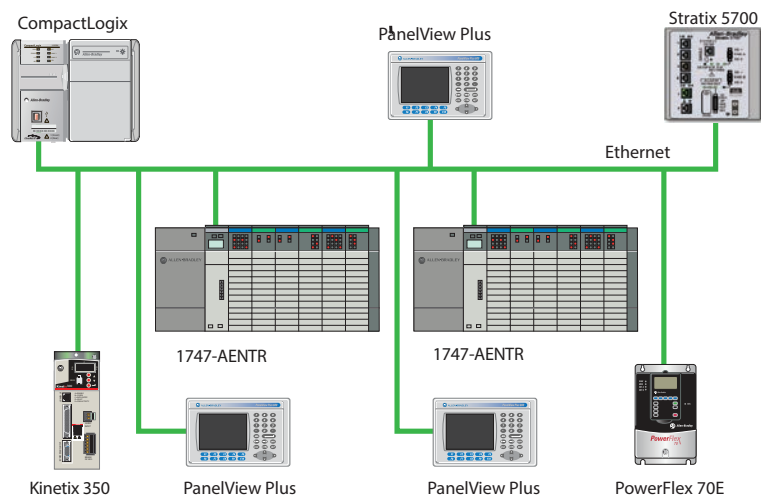

See the following publications for more information:

- PanelView Plus Terminals
 - For selecting your terminal: [VIEW-SG001](#)
 - For installing and operating your terminal: [2711P-UM001](#)
- PowerFlex Drives
 - For selecting your drive: [PLEX-SG002](#)
 - PowerFlex® 700S Adjustable Frequency AC Drive - Phase II Control (Frames 1...6) Installation Instructions, publication [20D-IN024](#). Provide information needed to install and wire a PowerFlex 700S Phase II Adjustable Frequency AC drive.
 - PowerFlex® 700H Adjustable Frequency AC Drive / PowerFlex 700S High Performance AC Drive, Frames 9...14 Installation Instructions, publication [PFLEX-IN006](#). Provides drive mounting and wiring information.
 - PowerFlex 700S High Performance AC Drive- Phase I Control Reference Manual, publication [PFLEX-RM002](#) Provides information on specifications and dimensions, mounting, and detailed drive operation for the PowerFlex 700S with Phase I control.
 - PowerFlex 700S High Performance AC Drive - Phase II Control Reference Manual, publication [PFLEX-RM003](#) Provides information on detailed drive operation for the PowerFlex 700S with Phase II control.
 - PowerFlex 700S High Performance AC Drive - Phase II Control Programming Manual, publication [20D-PM001](#) Provides information needed to start-up, program and troubleshoot PowerFlex 700S Phase II Adjustable Frequency AC drives.
 - PowerFlex 700S with Phase II Control Technical Data, publication [20D-TD002](#) Provides information on options, specifications, ratings, dimensions, derating data, and other product information.
 - PowerFlex 700H Adjustable Frequency AC Drive Programming Manual, publication [20C-PM001](#) Provides basic information needed to start-up, program and troubleshoot the PowerFlex 700H Adjustable Frequency AC Drive.
 - Wiring and Grounding Guidelines for Pulse Width Modulated (PWM) AC Drives, publication [DRIVES-IN001](#) Provides basic information needed to properly wire and ground PWM AC drives.
- Kinetix Motion Control
 - For information about motion control: [GMC-SG001](#)

Program Conversion Errors (PCE) Messages

Introduction

[Table 2](#) lists all of the messages that are generated with a PCE instruction. The text is appended to the rung comments that have the PCE instruction. The message text begins with asterisks (*) and the words “Generated by Translation Tool”, and ends with asterisks.

[Table 2](#) lists the message identifiers, descriptions, and when they are logged.

Table 2 - PCE Messages

ID	Text	When logged
101	The address references a counter's Update Accum (UA) bit field. This is not supported in the Logix Designer application.	Each time a reference to a counter's UA field is encountered (SLC only)
102	The address references a counter's Overflow(OV) or Underflow(UN) field. This has been translated but the translation needs to be validated.	Each time a reference to a counter's OV or UN field is encountered
103	Warning: Status files do not exist in the Logix Designer application. GSV instructions are used in the Logix Designer application to obtain controller information where applicable. This translation must be validated.	Each time a reference to the S file is encountered
105	The address references an indirect file number. It was not translated.	Each time an address reference with an indirect file number is encountered
107	The address reference may have an incorrect index. The translation needs to be validated.	Each time suitable index into the array could not be determined
108	The BTR, BTW or MSG instruction has been translated. However, the translation needs to be validated. These instructions have many parameters that cannot be directly translated and require review.	Each time a BTR, BTW or MSG instruction is translated
109	PLC-5 and SLC s use 0.01 second and 1 second timebases. the Logix Designer application uses a 0.001 second time base. The address references a 's Accumulator (ACC) field. The translation needs to be validated.	Each time a reference to a 's ACC field was encountered
110	PLC-5 and SLC s use 0.01 second and 1 second timebases. the Logix Designer application uses a 0.001 second time base. The address references a 's Preset (PRE) field. The translation needs to be validated.	Each time a reference to a 's PRE field was encountered
113	Follow the <FBC or DDT> instruction with MOV and FAL instruction on parallel branches to make sure the correct bits are being operated on.	Each FBC and DDT instruction
114	Although the PID instruction has been translated, the PID instruction has many parameters that do not translate directly to the Logix Designer application. The translation must be verified.	Each time a PID instruction is translated
115	16-bit parameters have been extended to 32-bit. Verify bit manipulation is correct.	Each time BSL, BSR, BTD instruction is translated
116	The structure of FOR/NXT/BRK statements has changed in the Logix architecture. In the PLC-5 processor, the FOR and NXT instruction enclosed a section of code that was to be iterated multiple times, while the BRK instruction provided a way to break out of the repeating code. In the RSLogix architecture, the FOR instruction calls a given routine a specific number of times, so a NXT instruction is not needed. The BRK instruction works in a similar fashion as in the PLC-5 processor. Because this architecture change is significant, you may need to restructure your logic.	Each time FOR/NXT/BRK instructions are encountered
117	AGA instruction not supported.	Each time a AGA instruction is found
119	CIR/COR not supported.	Each time a CIR or CIO instruction is found

Table 2 - PCE Messages

ID	Text	When logged
120	Source and destination types differ	When source and destination types differ in a COP instruction
121	DFA instruction not supported	Each time a DFA instruction is found
122	ERI/ERO instruction not supported.	Each time a ERI or ERO instruction is found
123	IDI/IDO instruction not supported.	Each time a IDI or IDO instruction is found
124	IIN/IOT instruction not supported.	Each time a IIN or IOT instruction is found
128	SFC routines aren't translated.	Each time a SFR or EOT instruction is found
129	Online edit instructions are not supported.	Each time a SDS, SJZ or SRZ instruction is found
130	User Interrupt instructions not supported.	Each time a UID, UIE or UIF instruction is found
131	DDV instruction not supported.	Each time a DDV instruction is found
132	High Speed Counter instructions not supported.	Each time a HSC/HSD/HSE/ SL or RHC/RAC/TDF instruction is found
133	I/O Interrupt Enable/Disable instructions not supported.	Each time a IID or IIE instruction is found
134	IIM/IOM instruction not supported.	Each time a IIM or IOM instruction is found
135	INT instruction not supported.	Each time a INT instruction is found
136	REF instruction not supported.	Each time a REF instruction (in SLC) is found
137	RPI instruction not supported.	Each time a RPI instruction is found
138	Selectable Timed Interrupt instructions not supported.	Each time a STD/STE or STS instruction is found
139	SUS instruction not supported.	Each time a SUS instruction is found
141	RMP instruction not supported.	Each time a RMP instruction is found
142	RPC instruction not supported.	Each time a RPC instruction is found
143	SVC instruction not supported.	Each time a SVC instruction is found
144	SWP instruction not supported.	Each time a SWP instruction is found
145	SQC instruction not supported.	Each time a SQC instruction is found
146	INV instruction not supported.	Each time a INV instruction is found
147	DCD/ENC instruction not supported.	Each time a DCD or ENC instruction is found
148	The CEM, DEM, or EEM instruction has been translated. However, the translation needs to be validated. These instructions have many parameters that cannot be directly translated and require review.	Each time a CEM, DEM or EEM instruction is found
149	Modbus messaging is not supported in the Logix Designer application.	If MSG instruction is configured for Modbus
150	MSG instruction and associated MESSAGE tag need to be manually verified.	Each time a MSG instruction is found
151	WARNING: Status files do not exist in the Logix Designer application. However this status file value is handled through the StatusFile routine.	S file type indexes that can be directly translated to functionality in the Logix Designer application
152	the Logix Designer application has a different fault handling mechanism than the PLC-5/SLC. This fault routine will not be called.	Start of identified legacy processor fault routine
153	This PII/DII routine is not used by the Logix Designer application.	Start of identified legacy processor PII/DII routine

I/O Modules

Supported I/O Modules

The majority of 1746 and 1747 discrete, analog, and specialty modules are compatible with the 1747-AENTR adapter.

[Table 3](#) provides a list of supported modules.

Table 3 - I/O Modules Supported by the 1747-AENTR Adapter

Catalog Number	Type	Catalog Number	Type
1746-IA4	AC Digital Input Module	1746-OG16	DC Digital Output Module
1746-IA8	AC Digital Input Module	1746-OV8	DC Digital Output Module
1746-IA16	AC Digital Input Module	1746-OV16	DC Digital Output Module
1746-IB8	DC Digital Input Module	1746-OV32	DC Output Module
1746-IB16	DC Digital Input Module	1746-OVP16	DC Digital Output Module
1746-IB32	DC Input Module	1746-OW4	AC/DC Relay Output Module
1746-IC16	DC Digital Input Module	1746-OW8	AC/DC Relay Output Module
1746-IG16	DC Digital Input Module	1746-OW16	AC/DC Relay Output Module
1746-IH16	DC Digital Input Module	1746-OX8	AC/DC Relay Output Module
1746-IM4	AC Digital Input Module	1746-FIO4I	Analog Combination Module
1746-IM8	AC Digital Input Module	1746-FIO4V	Analog Combination Module
1746-IM16	AC Digital Input Module	1746-INT4	Thermocouple Isolated Input Module
1746-IN16	AC/DC Digital Input Module	1746-NI4	Analog Input Module
1746-IO4	Digital Combination Module	1746-NI8 ⁽¹⁾	Analog Input Module
1746-IO8	Digital Combination Module	1746-NIO4I	Analog Combination Module
1746-IO12	Digital Combination Module	1746-NIO4V	Analog Combination Module
1746-IO12DC	Digital Combination Module	1746-NO4I	Analog Output Module
1746-ITB16	DC Digital Input Module	1746-NO4V	Analog Output Module
1746-ITV16	DC Digital Input Module	1746-NR4	RTD/Resistance Input Module
1746-IV8	DC Digital Input Module	1746-NT4	Thermocouple/mV Input Module
1746-IV16	DC Digital Input Module	1746-NI16V ⁽¹⁾	Analog Input Module
1746-IV32	DC Digital Input Module	1746-NI16I ⁽¹⁾	Analog Input Module
1746-OA8	AC Digital Output Module	1746-NR8 ⁽¹⁾	RTD/Resistance Input Module
1746-OA16	AC Digital Output Module	1746-NT8	Thermocouple/mV Input Module
1746-OAP12	AC Digital Output Module	1746-NO8I ⁽¹⁾	Analog Output Module
1746-OB6EI	DC Digital Output Module	1746-NO8V ⁽¹⁾	Analog Output Module
1746-OB8	DC Digital Output Module	1746-HSTP1	Stepper Controller Module

Table 3 - I/O Modules Supported by the 1747-AENTR Adapter

Catalog Number	Type	Catalog Number	Type
1746-OB16	DC Digital Output Module	1746-HSCE ⁽²⁾	High-Speed Counter Module
1746-OB16E	DC Digital Output Module	1746-HSCE2 ⁽¹⁾	Multi-Channel High-Speed Counter Module
1746-OB32	DC Digital Output Module	1746-QS ⁽²⁾	Synchronized Axes Control Module
1746-OB32E	DC Digital Output Module	1746-OBP16	DC Digital Output Module
1746-OBP8	DC Digital Output Module	1746-BAS/B ⁽¹⁾⁽²⁾	BASIC Module
		1746-BAS-T ⁽¹⁾⁽²⁾	BASIC Module

(1) This module supports multiple operating classes. The 1747-AENTR adapter automatically promotes multiclass modules to the highest supported class. The 1746-NI16I, 1746-NI16V, 1746-NR8, 1746-NI8, 1746-NO8I, 1746-NO8V modules are promoted from class 1 to class 3. The 1746-BAS/B, 1746-BAS-T, and 1746-HSCE2 modules are promoted from class 1 to class 4.

(2) This specialty module uses Advanced module connection. Refer to the user manual specific to the I/O module to learn about its connection configuration requirements.

Unsupported I/O Modules

[Table 4](#) lists unsupported modules. You can also have third-party SLC I/O modules in your system. Contact the third-party supplier to determine their product's compatibility. In general, third-party modules can be supported as long as the modules use fewer than 250 integer words and do not use G-files. However, a new EDS file needs to be developed to make the third-party module compatible with the 1747-AENTR adapter. If these modules are used in the current system, other plans must be made to incorporate the modules into a Logix system.

Consult the SLC EtherNet/IP Adapter Module user manual, publication [1747-UM076](#) for the latest list of supported and unsupported modules.

Table 4 - I/O Modules NOT Supported by the 1747-AENTR Adapter

Catalog Number	Type
1746-HSRV	Servo Control Module
1746-BTM ⁽¹⁾	Barrel Temperature Module
1747-DCM1 ⁽¹⁾	Direct Communication Modules
1747-DCM2 ⁽¹⁾	
1747-DCM3 ⁽¹⁾	
1747-DCM4 ⁽¹⁾	
1747-KE/A ⁽¹⁾	DH-485/RS-232C Interface Modules
1747-KE/B ⁽¹⁾	
1747-KFC15	ControlNet to RS-232C Interface Module
1747-SDN/D ⁽¹⁾	DeviceNet Scanner module
1747-SCNR ⁽¹⁾	ControlNet Scanner module
1747-SN	Remote I/O Scanner Module
1747-BSN	Back-Up Remote I/O Scanner Module
1746-QV	Open Loop Velocity Control Module
1746-BLM	Blow Molding Module
1746-MPM	Mold Pressure Module
1203-SM1 ⁽¹⁾	Scanport Module (Class 4 operation)

(1) The module is not supported by the 1747-AENTR but appears in the the Logix Designer application pick list (Select Module Type dialog box).

IMPORTANT Any 1746/1747 module that is not included in the lists of supported and unsupported modules is **not** supported by the 1747-AENTR, as of the date of writing of this user manual.

Consult the manufacturer of any third-party module to determine if the module is supported by the 1747-AENTR adapter.

Notes:

Performance Expectations

The data provided here was gathered by using real world testing and is provided as a guide to help you determine your expected results. The system consisted of a 1769-L36ERM module and a rack of 1746 I/O modules of different sizes and types. No two systems are alike and your system may be different than shown here. Use this data to help manage your performance expectations.

- Testing goal was to keep both the 1769-L36ERM % CPU and the 1747-AENTR % CPU under approximately 70%.
- Each user I/O module configuration is unique in terms of number and types of modules within the chassis. Test results vary based on exact chassis configuration.
- The data was gathered with all modules contained in a single 1746 chassis.
- RPIs of the various modules within the chassis do not need to be equal. You can adjust individual module RPIs to meet your application needs. The RPIs used in these tests were to extremely tax the system. Using RPIs of 2 and 4 mS is not considered typical.

Table 5 - Performance - For Reference Only

Modules in chassis, tested to max size chassis 13 slots 1 - 1747-AENTR module 12 - I/O modules	1 - 1746-IB16 1 - 1746-OB16 (best case throughput)	1 - 1746-BAS 2 - 1746-NT4 2 - 1746-IB16 2 - 1746-OB16	1 - 1746-BAS 2 - 1746-NT4 5 - 1746-IB16 4 - 1746-OB16
All modules configured for same RPI	2 ms	2 ms	4 ms
Total number of INPUT bytes transferred across backplane	12	212	244
Total number of OUTPUT bytes transferred across backplane	4	184	192
L36ERM % Ethernet CPU, I/O Comms Utilization (Actual)	20%	71.5%	60.8%
1747-AENTR % CPU	23%	68%	66%
1747-AENTR backplane scan time Max/Avg	2 ms/2 ms	5 ms/5 ms	5 ms/5 ms
Typical discrete throughput with minimal Logix program scan (less than 1 ms)	7...11 ms	11...19 ms	12...19 ms
Typical discrete throughput with 15 ms Logix program scan	7...39 ms	12...47 ms	12...50 ms
Typical discrete throughput with 30 ms Logix program scan	9...70 ms	12...76 ms	11...85 ms

While the Logix controller might not scan the I/O in the 1747-AENTR chassis as quickly as the SLC scans the I/O as local I/O, you may still see an overall performance improvement after the conversion to Logix because you are likely to see a significant program scan time decrease.

IMPORTANT Logix Designer application version 21 and later, and 1747-AENTR module firmware revision 2.001 and later, support configurations of multiple physical 1746 chassis connected by cables and scanned by a single 1747-AENTR module. Multi-chassis support lets you use up to 3 physical chassis, with a maximum of 30 I/O slots, scanned by a single 1747-AENTR module.

The 1747-AENTR firmware revisions prior to revision 2.001 support only a single physical chassis and 13 I/O slots maximum.

When the 1747-AENTR module is used in a multi-chassis system you can expect slower performance than the data presented in [Table 5](#). The backplane scan time can increase by as much as 35% especially in systems with a large number of Input and Output bytes transferred across the backplane. The minimum RPI is also affected by the number of I/O modules within the chassis. For a 30-I/O-module chassis, the RPI must be at least 11 mS.

IMPORTANT Performance is affected by the Logix controller % CPU, 1747-AENTR % CPU, number of bytes In/Out transferred across the 1746 backplane, 1746 backplane scan time and Ethernet bandwidth. Your results may vary from the data in the table. The data in the table is meant for reference only.

Advanced Modules

Use Advanced Modules in a Logix System

The SLC 500 EtherNet/IP Adapter user manual, publication [1747-UM076](#), has a section titled 'Add Specialty I/O Modules Using Advanced Connection' that covers using these modules. If your system has any of the advanced modules, you must review that section and plan accordingly.

Follow these steps to incorporate an advanced module in a Logix system.

1. On the General tab, configure the total size and type of data (SINT, INT, DINT, REAL) that exists in the SLC environment for your advanced module.

The values placed here determine the type and size of tag created in the Logix environment.

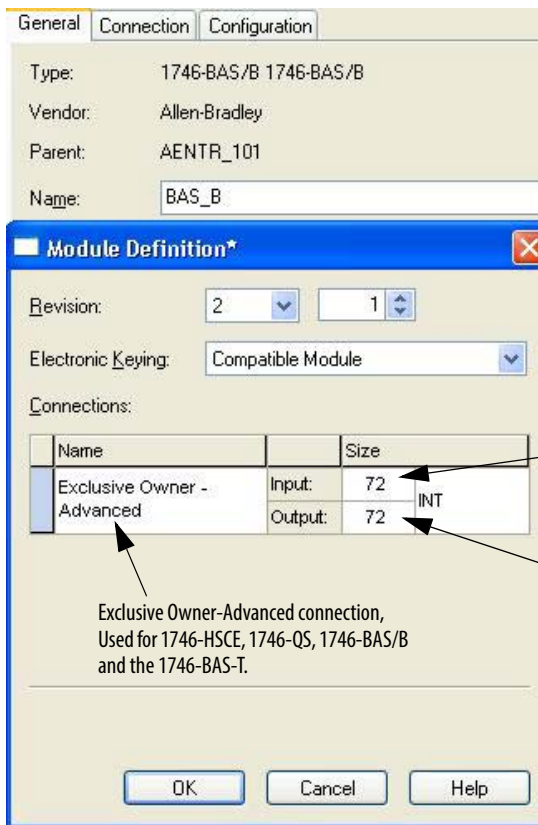

General concepts about using an Advanced Module

Input size includes 8 Input words and 64 M1 words for a total of 72.

Output size includes 8 Output words and 64 M0 words for a total of 72.

Exclusive Owner-Advanced connection, Used for 1746-HSCE, 1746-QS, 1746-BAS/B and the 1746-BAS-T.

- On the Configuration tab, you are directing the Logix controller where and how to place the data from the Advanced module into the Logix tag.

Remember the advanced module is actually supplying Input data, Output data, M1 data and M0 data. This tab configures how to distribute the Advanced module data into the Logix tag.

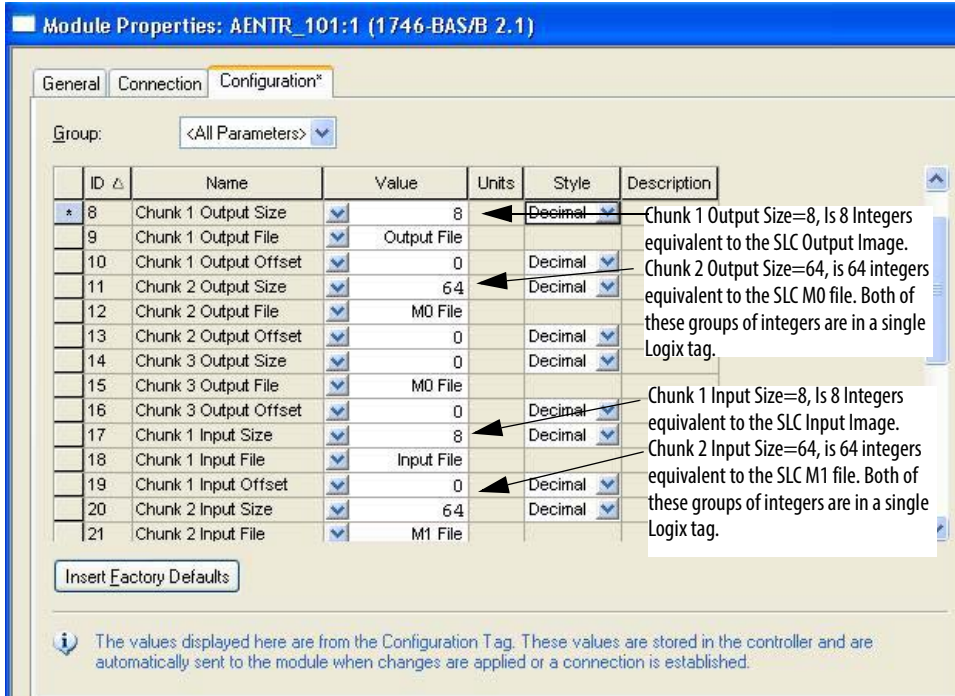

This Configuration dialog box maps Input data, Output data, M0, and M1 data from the SLC environment and places that data in a single Logix Input and Output tag.

This is the Logix tag created with the Advanced module. The tag is a simple array (no descriptive tag names) of the size specified on the Module Definition dialog box from the Configuration tab. All of the data to/from the 1746 module show up in this tag based on the mapping specified on the Configuration tab.

[-] AENTR_101:1:I	{...}			AB:1746_BASB_504289DA:1:0
[-] AENTR_101:1:I.ConnectionFaulted	0	Decimal		BOOL
[-] AENTR_101:1:I.Data	{...}	Decimal		INT[72]
[+] AENTR_101:1:I.Data[0]	0	Decimal		INT
[+] AENTR_101:1:I.Data[1]	0	Decimal		INT
[+] AENTR_101:1:I.Data[2]	0	Decimal		INT
[+] AENTR_101:1:I.Data[3]	0	Decimal		INT

A 72 Integer tag is created to hold the Input data and M1 data. This tag is a simple array with no descriptive tags.

[-] AENTR_101:1:O	{...}			AB:1746_BASB_7F28A5EE:0:0
[-] AENTR_101:1:O.Data	{...}	Decimal		INT[72]
[+] AENTR_101:1:O.Data[0]	0	Decimal		INT
[+] AENTR_101:1:O.Data[1]	0	Decimal		INT
[+] AENTR_101:1:O.Data[2]	0	Decimal		INT
[+] AENTR_101:1:O.Data[3]	0	Decimal		INT

A 72 Integer tag is created to hold the Output data and M0 data. This tag is a simple array with no descriptive tags.

Numerics

1746-BAS/B 18
1746-BAS-T 18
1746-HSCE 18
1746-QS 18
1747-AENTR 8
 1747-SDN 17
 1747-SN 12
 add I/O on-line 10
 advanced modules 75
 BTR 12
 BTW 12
 connect through RJ45 64
 connections 9
 install 62
 IP address 61
 local I/O 11
 power considerations 19
 rack optimization 9
 redundant system 10
 remote I/O 12
 supported I/O 69
 supported rack size 14
 unsupported I/O 70
1747-SDN 17

A

adapter 8
 connections 9
add I/O on-line 10
additional resources 6
advanced modules 18, 75
ASCII file 44
asynchronous scans 13

B

backplane
 power considerations 19
 power requirements 62
boot time 13
BootP/DHCP 61

C

chassis 63
code conversion 44
communication
 SLC to Logix 56
communication networks
 DH+ 18
 DH485 18
 Ethernet 18
 serial 18
CompactLogix system 26

connection types
 exclusive owner 9
 input only 9
 listen only 9
 none 9
conversion errors 51
converting
 messages 67
 verifying 54

D

device-level ring 17
DeviceNet network 17
DH+ communication 18
DH485 communication 18
DHCP 61
DHCP enabled 61
download
 Integrated Architecture Builder 7

E

EDS files 14
errors
 syntax 51
Ethernet network 18
 remote I/O connection 36
EtherNet/IP network
 connection 64
exclusive owner 9, 18

F

file conversion 44
file translation 43
future requirements 17
 device-level ring 17
 DeviceNet network 17

I

I/O
 asynchronous 13
 issues with I/O modules 57
 local rack 11
 remote rack 12
 retaining 14
 scan time 11
 synchronous 13
I/O tree 9, 14
I1 files 17
input only 9

Integrated Architecture Builder

- add a chassis 33
- bill of material 41
- download 7
- location 7
- network connection 36
- replace with CompactLogix 26
- retain I/O 20

integrated architecture builder 20**IP address 61****L****listen only 9****local I/O 11****Logix**

- boot time 13
- memory comparison 11
- scan time 11

Logix Designer 5**Logix I/O**

- I/O tree 9

M**M0 files 17, 18, 76****M1 files 17, 18, 76****map messages 56****memory comparison**

- SLC to Logix 11

message instructions 55**migration**

- add a chassis 33
- future requirement 17
- Integrated Architecture Builder 20
- integrated architecture builder 20
- replace with CompactLogix 26
- retain I/O 20

migration planner 15**migration wizard 20****module discovery 10****N****network address 61****network connection 64****none 9****O****00 files 17****overview 7**

- SLC EtherNet/IP adapter module 8

P**PCE**

- locating instructions 54
- message instructions 55
- recognizing instructions 55
- resolving 53, 55
- timer instructions 55

PCE message list 67**PCE messages 67****performance 12****performance expectations 73****power considerations 19****power requirements 62****program conversion error**

- locate 54
- recognizing instructions 55
- resolving 53, 55

project bill of material 41**R****rack optimization 9****redundant Logix system 10****remote I/O 12, 33**

- BTR 12
- BTW 12
- network connection 36
- scan time 12

replacing other components 66**requirements**

- power 62

resolving

- program conversion error 55

resources 6, 7**retain I/O 14, 20****RJ45**

- wire 64

RPI 11**RS232 port 19****RSLogix 5000 5**

- file translation tool 43

S**scan time comparison 11****scan times 73****serial communication 18****SLC**

- memory comparison 11
- replace with CompactLogix 26
- scan time 11

SLC EtherNet/IP adapter module

- connections 9
- overview 8

SLC I/O

- local rack size 14
- remote rack size 14

Studio 5000 5

support
add on-line 10
module discovery 10
supported I/O 69
supported rack size 14
switches
network 61
synchronous scans 13
syntax errors 51

T

TCP 62
timer issues 55
timer.ACC 55
timer.PRE 55
tools
file translation 43
integrated architecture builder 7
migration planner 15
translate program 48
translation tool
expectations 43
RSLogix 500 48
RSLogix 5000 48

U

unsupported I/O 70

V

verifying 54

Notes:

Rockwell Automation Support

Rockwell Automation provides technical information on the Web to assist you in using its products.

At <http://www.rockwellautomation.com/support>, you can find technical manuals, technical and application notes, sample code and links to software service packs, and a MySupport feature that you can customize to make the best use of these tools. You can also visit our Knowledgebase at <http://www.rockwellautomation.com/knowledgebase> for FAQs, technical information, support chat and forums, software updates, and to sign up for product notification updates.

For an additional level of technical phone support for installation, configuration, and troubleshooting, we offer TechConnectSM support programs. For more information, contact your local distributor or Rockwell Automation representative, or visit <http://www.rockwellautomation.com/support/>.

Installation Assistance

If you experience a problem within the first 24 hours of installation, review the information that is contained in this manual. You can contact Customer Support for initial help in getting your product up and running.

United States or Canada	1.440.646.3434
Outside United States or Canada	Use the Worldwide Locator at http://www.rockwellautomation.com/support/americas/phone_en.html , or contact your local Rockwell Automation representative.

New Product Satisfaction Return

Rockwell Automation tests all of its products to help ensure that they are fully operational when shipped from the manufacturing facility. However, if your product is not functioning and needs to be returned, follow these procedures.

United States	Contact your distributor. You must provide a Customer Support case number (call the phone number above to obtain one) to your distributor to complete the return process.
Outside United States	Please contact your local Rockwell Automation representative for the return procedure.

Documentation Feedback

Your comments will help us serve your documentation needs better. If you have any suggestions on how to improve this document, complete this form, publication [RA-DU002](#), available at <http://www.rockwellautomation.com/literature/>.

Rockwell Otomasyon Ticaret A.Ş., Kar Plaza İş Merkezi E Blok Kat:6 34752 İçerenköy, İstanbul, Tel: +90 (216) 5698400

www.rockwellautomation.com

Power, Control and Information Solutions Headquarters

Americas: Rockwell Automation, 1201 South Second Street, Milwaukee, WI 53204-2496 USA, Tel: (1) 414.382.2000, Fax: (1) 414.382.4444
Europe/Middle East/Africa: Rockwell Automation NV, Pegasus Park, De Kleetlaan 12a, 1831 Diegem, Belgium, Tel: (32) 2 663 0600, Fax: (32) 2 663 0640
Asia Pacific: Rockwell Automation, Level 14, Core F, Cyberport 3, 100 Cyberport Road, Hong Kong, Tel: (852) 2887 4788, Fax: (852) 2508 1846