

# Bulletin 1492 PLC I/O Wiring Conversion System for Allen-Bradley® 1771 to 1756 ControlLogix™ I/O

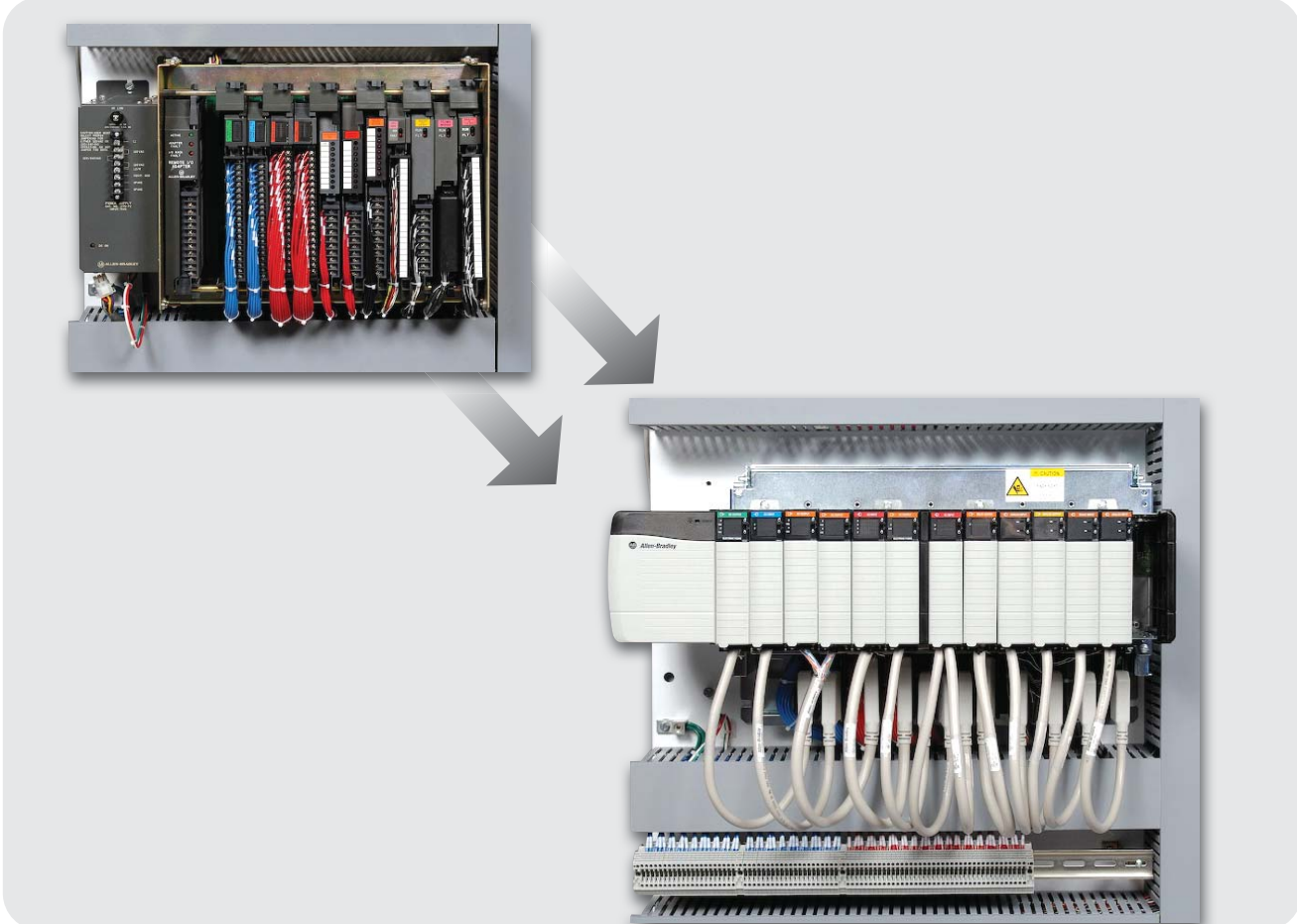

Selection Guide



LISTEN.  
THINK.  
SOLVE.®



# Bulletin 1771 to 1756 I/O Field Wiring Conversion System



## Bulletin 1771 PLC to ControlLogix 1756 I/O Field Wire Conversion System

### Field Wire Conversion System

The Bulletin 1492 PLC 1771 to ControlLogix 1756 I/O field wire conversion system provides a fast and efficient way to convert the existing I/O field wires from a bulletin 1771 I/O system to a Bulletin 1756 I/O system. The Bulletin 1492 conversion system enables the field wiring on a particular Bulletin 1771 I/O module terminal block (swing-arm) to be maintained, so there is no or very limited rewiring required to convert to a compatible 1756 I/O module. Conversion solutions are available for 22 of the most widely used 1771 I/O modules.

### Table of Contents

Time Saving Features....	this page
Conversion Modules and Cables .....	4
Conversion of the Bulletin 1771 I/O Housing.....	5
Selection Table for 1771-to-1756 Digital I/O Swing-Arm Conversion Modules and Pre-Wired Cables...	6
Typical Keys to Conversion Success: 1771-to-1756 Field Wire Conversion System .....	7
Conversion Module Specifications .....	8
Conversion Module Installation and Application Considerations .....	9

## Time Saving Features

The time to convert for example the field wiring for a 1771 8-slot I/O chassis without the conversion system can typically be between seven to nine hours.\*

This assumes time to:

- Unscrew and remove each I/O wire from each I/O module terminal block
- Remove the old I/O housing/rack from the control cabinet
- Drill new holes in the control cabinet for the new 1756 I/O chassis
- Mount the new I/O chassis
- Install the new I/O modules in the new I/O chassis
- Re-dress each I/O wire for each module
- Re-label each I/O wire
- Attach each wire to the I/O module terminal block
- Confirm operation: Once the conversion of field wires is complete the integrity of each connection has to be verified to ensure a wiring error wasn't made. This troubleshooting process may add 30 minutes or several hours to the conversion. The conversion system potentially reduces the 7 to 10 hours required to convert the field wiring for an 8-slot I/O housing/rack to one hour or less. In many applications, saving 6 to 8 hours of downtime can eliminate tens to hundreds of thousands of dollars of revenue. Multiply that savings by the number of 8-slot housings in your factory and you can see the benefit of the I/O conversion system.

## 1492 Conversion System BASICS

### Conversion Modules and Cables

The Bulletin 1492 conversion system virtually eliminates the rewiring process by using conversion modules. The conversion modules provide the mating connections to the specific 1771 I/O swing-arm with the attached field wires. It routes those field signals, via a 1492 wiring system connector and a 1492 pre-wired cable to the compatible terminals of the 1756 I/O module.



*Conversion Modules*



*Pre-wired 1492 Cables*

### Conversion Assembly Base-Plate

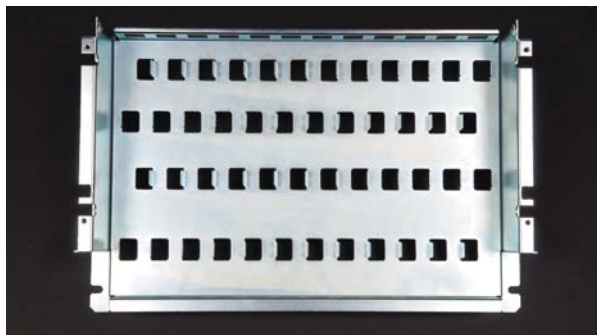

The conversion modules are housed in a conversion assembly base-plate which uses the same mounting footprint and panel mounting holes as the 1771 I/O Chassis it replaces. Therefore, no new holes need be drilled in the control cabinet.

### Conversion Assembly Cover-Plate



The conversion assembly cover-plate covers and protects the conversion modules, while providing the mounting platform for the Bulletin 1756 I/O chassis and associated I/O modules.

The cover-plate comes with pre-drilled and tapped holes, which allow mounting the 1756 chassis in several locations (left, center, or right).

NOTE: The total depth of the conversion assembly and mounted Bulletin 1756 chassis is approximately 10.5 inches.

# Bulletin 1771 to 1756 I/O Field Wiring Conversion System

## Conversion Systems Components - Exploded View

The following illustration provides an overview of the conversion components.

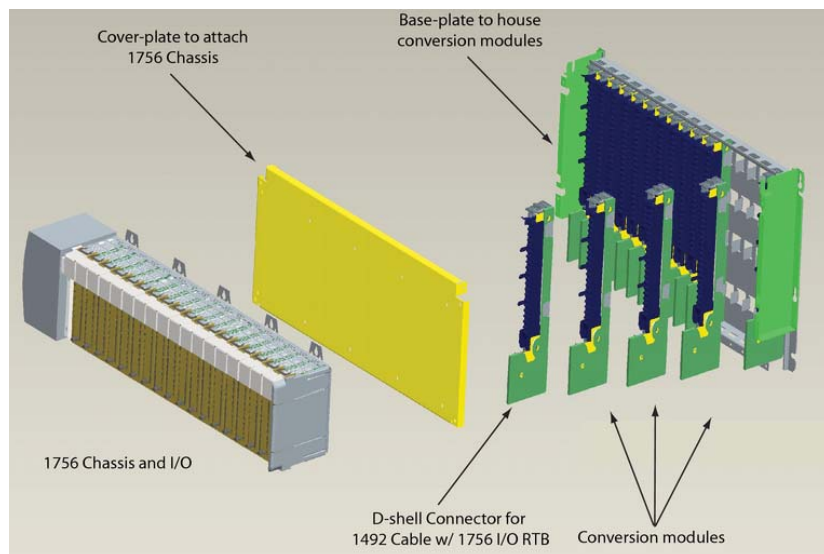

## Conversion of the Bulletin 1771 I/O Housing

Table 1 provides selection information for the conversion assembly base-plate and cover-plate. The selection process is based on the previously installed Bulletin 1771 housing. These components function as a matched set and therefore ship as a single catalog number.

## Bulletin 1771 to Bulletin 1756 Chassis Conversion System Selection Process

Step 1: Determine the number of 1771 I/O modules used in the 1771 I/O Chassis to be converted to 1756. NOTE: In some cases two 1756 modules may be required for one 1771 module. Select the applicable 1492 conversion modules from the Digital and Analog Conversion Selection Table Matrix (Table 2 and 3).

Step 2: Review the Max Slots for I/O and Chassis Width data from Table 1, and select a 1756 I/O Chassis which meets your conversion needs from Step 1. Ensure the information from the I/O Conversion module tables 2 and 3 on page 4 and 5 are reviewed first.

Step 3: Once the 1756 Chassis is selected, select the Conversion Assembly. The conversion assembly has the same dimensional foot-print as the 1771 chassis (without power supply) and can use the same mounting hardware. The assembly consists of a base-plate to hold the conversion modules and a cover-plate to protect the modules and to mount the selected 1756 chassis. The combined depth of the conversion assembly with the 1756 chassis mounted is 10.25 inches (Controller w/key) to 10.0 inches (controller w/o key).

Table 1: Bulletin 1771 to 1756 Chassis Conversion System Selection Process

Chassis Parameter *	Bulletin 1771 Chassis		Bulletin 1756 Equivalent Chassis		Bulletin 1771 Chassis		Bulletin 1756 Equivalent Chassis		Bulletin 1771 Chassis without Power Supply ‡	Equivalent 1756 Chassis	Bulletin 1771 Chassis without Power Supply ‡	Equivalent 1756 Chassis
	-A1B without PS	-A1B with PS	-A4 †	-A7	-A2B without PS	-A2B with PS	-A7 §	-A10	-A3B1	-A13 ¶	-A4B	-A17 >
Max Slots for I/O	4	4	3	6	8	8	6	9	12	12	16	16
Chassis Width ‡	9.01	12.61	10.35	14.49	14.01	17.61	14.49	19.02	19.01	23.15	24.01	29.06
Mounting Assembly	1492-MUA1B-A4-A7				1492-MUA2B-A7-A10				1492-MUA3-A10-A13		1492-MUA4-A13-A17	

\* 1771-A3B is not listed as it is used for 19 inch wide instrumentation panels.

‡ Two 1771 width dimensions are provided. The dimension without PS (power supply) is used when a 1771 chassis slot mounted power supply (e.g. 1771-P4S, -P6S, etc) is used. The dimension with PS includes a 1771 chassis left side mounted power supply (e.g. 1771-P1, -P2, etc.). Notice that in some cases the width dimension of the 1756 chassis (including its power supply) exceeds the width of the 1771 chassis with or without the 1771 chassis left side mounted supply. For conversion flexibility the conversion cover plate has pre-drilled and taped holes to allow mounting several different 1756 chassis to account for differences in I/O slot usage and width dimension. Cover plate hole locations allow the excess 1756 chassis width to be evenly distributed to both sides, or excess to right or left. Carefully consider this when mounting.

† 1756-A4 may work in a 1771-A1B application if four or less I/O slots were used. Conversion cover-plate is capable of mounting -A4 or -A7

§ 1756-A7 may work in a 1771-A2B application if six or less I/O slots were used. Conversion cover-plate is capable of mounting -A7 or -A10

¶ 1756-A10 may work in a 1771-A3B1 application if nine or less I/O slots were used. Conversion cover-plate is capable of mounting -A10 or -A13

> 1756-A13 may work in a 1771-A4B application if 12 or less I/O slots were used. Conversion cover-plate is capable of mounting -A13 or -A17

‡ An external power supply (eg. 1771-P2) adds 3.6 inches to the width dimension.

# Bulletin 1771 to 1756 I/O Field Wiring Conversion System

## Selection Table for 1771-to-1756 Digital I/O Swing-Arm Conversion Modules and Pre-Wired Cables

### How to use Table 2

Step 1: In the left most column, find the catalog number of the 1771 digital I/O module

Step 2: Follow that row to the right most column to find the compatible 1756 I/O module. In some cases more than one 1756 module exists. Review the table and wiring diagrams on pages 7-33 carefully and compare the 1771 and 1756 I/O module Installation Manuals with attention to the specifications to determine full compatibility.

Step 3: Find the column in the row you selected that contains a capital letter (e.g. X) and/or letters/numbers (XE & S1). The catalog number of the 1492 1771-to-1756 Converter is listed at the top of that column. The capital letters/letter or number/letter from the row and column intersection indicates the last character(s) of the catalog number for the 1492 cable that connects from the converter module to the 1756 I/O module (right most column). The FULL cable catalog number is 1492-CONCAB①xx, where xx is the above letter/letter or letter/number combination, except for XE selection (1492-C①②XE)

Table 2: Conversion of the I/O Modules - Digital

1771 Digital I/O Module	Cat. Numbers: 1492 Converter for 1771-to-1756 Digital I/O														Compatible 1756 Digital I/O Module
	1492-CM1771-LD001	1492-CM1771-LD002	1492-CM1771-LD003	1492-CM1771-LD004	1492-CM1771-LD005	1492-CM1771-LD006	1492-CM1771-LD007	1492-CM1771-LD008F*	1492-CM1771-LD009F*	1492-CM1771-LD010F*	1492-CM1771-LD011	1492-CM1771-LD012	1492-CM1771-LD013	1492-CM1771-LD014	
1771-IAD	X														1756-IA16
1771-IBD	X														1756-IB16
1771-IAD		Y													1756-IH16I
1771-IMD		Y													1756-IM16I
1771-IBN			Z												1756-IB32
1771-IAN			Z												1756-IA32
1771-ID16				Y											1756-IA16I
				Y											1756-IH16I
1771-IQ16				Y											1756-IB16I
1771-IVN					Z										1756-IV32
1771-OAD						X									1756-OA16
1771-OBBD						X									1756-OB16E
Two 1771-IA/IA2							XE‡								1756-IA16
1771-OBBD								S1§							Two 1756-OC8
1771-OBND									Z						1756-OB32
1771-OD16										Y					1756-OA16I
1771-OW16											Y				1756-OW16I
1771-OW												Y			1756-OX8I
1771-OAN													S3§		Two 1756-OA16
1771-OA														U	1756-OA8E

① Three digit number to indicates cable length in meters and tenths of meters (005=0.5 meters). Available lengths = 1.0 (010) and 0.5 (005) meters

② Three digit number to indicates cable length in meters and tenths of meters (005=0.5 meters). Available lengths = 1.0 (010) and 0.5 (005) meters

‡ One conversion module required for two (2) 1771-IA/IA2 modules. The 1492-C(1)(2)XE cable provides the two 1771 (8-pt) module into one 1756-IA16 (16-pt module) conversion.

§ The two 1756-OC8 (S1) or 1756-OA16 (S3) must be located directly next to each other in the 1756 chassis.

\* An F at the end of the conversion module catalog number indicates it is fused to match the functionality of the 1771 module being replaced.

> To understand any issues concerning I/O module compatibility refer to the conversion module wiring diagrams and the specific I/O module's Installation Manual especially the specification and wiring instruction sections.



# Bulletin 1771 to 1756 I/O Field Wiring Conversion System

## 1771 to 1756 Analog I/O Swing-Arm Conversion Modules and Pre-Wired Cables

### How to use Table 3

Step 1: In the left most column, find the catalog number of the 1771 analog I/O module.

Step 2: Follow that row to the right most column to find the compatible 1756 I/O module. Review the table and wiring diagrams on pages 9-33 and compare the 1771 and 1756 I/O module Installation Manuals with attention to the specifications to determine full compatibility.

Step 3: Find the column in the row you selected that contains a capital letter (e.g. A). The catalog number of the 1492 1771-to-1756 Converter is listed at the top of that column. The capital letter from the row and column intersection indicates the last character of the catalog number for the 1492 cable that connects from the converter module to the 1756 I/O module (right most column). The FULL cable catalog number is 1492-CONACAB⓪x, where x is the above letter.

**Table 3 - Conversion of the I/O Modules - Analog**

1771 Analog I/O Module	1492-CM1771-LA001	1492-CM1771-LA002	1492-CM1771-LA003	1492-CM1771-LA004	Compatible* 1756 Analog I/O Module
1771-IFE (S-ended voltage)	A				1756-IF16 (S-ended voltage)
1771-IFE (S-ended current)	B				1756-IF16 (S-ended current)
1771-IFE (Diff. voltage)		C			1756-IF16 (Diff. voltage)
1771-IFE (Diff. current)		D			1756-IF16 (Diff. current)
1771-OFE1			E		1756-OF6VI
1771-OFE2			E		1756-OF6CI
1771-IR				F	1756-IR6I

⓪ Three digit number to indicates cable length in meters and tenths of meters (005=0.5 meters). Available lengths = 1.0 (010) and 0.5 (005) meters.

\* To understand any issues concerning I/O module compatibility refer to the conversion module wiring diagrams and the specific I/O module's Installation Manual especially the specification and wiring instruction sections.

### Typical Keys to Conversion Success: 1771-to-1756 Field Wire Conversion System

Up front conversion planning and adequate conversion time budgeting are the key elements to field wire conversion success. The following are several points specific to these elements. There may be other points unique to your application or installation.

Typical keys to field wire conversion success are:

- Study and use Tables 1 - 3, select the correct 1492 conversion assemblies, modules and cables specific to your 1771 I/O system. If a 1492 conversion module is not listed in Tables 2 or 3, the 1756 I/O module needs to be manually converted/re-wired.
- Study and use the wiring diagrams specific to the 1771-to-1756 conversion modules being used. Pay particular attention to the Conversion Module Installation and Application Considerations that apply for each 1492 conversion module, especially items such as the PLC output module current load switching differences. In addition, compare the 1771 and 1756 I/O module specifications from the respective commercial, installation and/or user documents to ensure any implication of the differences are understood and appropriate system modifications are performed as part of the conversion.
- Order the 1492 conversion components—assembly, module, and cables, well in advance (8-12 weeks) of the shutdown scheduled to perform the conversion.
- When the 1492 conversion components arrive, inventory and physically inspect them to ensure nothing was damaged during shipment.

**Note:** It is recommended that several spares of each 1492 conversion module and cable be ordered to ensure a damaged component doesn't impact the scheduled date of the conversion due to possible shipment delay of the replacement component. The number of 1492 module X spares to order depends on how many of conversion module X is used in the conversion.

- Inspect the existing 1771 I/O swing-arm for any possible physical or electrical damage, prior to conversion. Damaged swing-arms should be replaced during the conversion to ensure reliable mechanical and electrical connection to the 1492 conversion modules.
- Fully review and understand the conversion system Installation Instruction manual. If possible, have assigned conversion personnel practice using the 1492 conversion hardware, so component assembly confusion is limited during the actual conversion.

## Conversion Module Specifications

Specifications *		Value
Dimensions (H x D x W)		300 x 111.25 x 38.1 mm (11.81 x 4.38 x 1.5 in.)
Approximate Shipping Weight (module dependant, refer to installation manual)		260g (0.57 lb)
Storage Temperature		-40...+85 °C (-40...+185 °F)
Operating Temperature		0...+60 °C (+32...+140 °F)
Operating Humidity		5...95% at +55 °C (+131 °F)
Shock	Non-operating	50 g
	Operating	30 g
Operational Vibration		2 g at 10...500 Hz
Agency Certifications		UL Classified (UL File No. E113724)
CE Certifications		Compliant for all applicable directives
Pollution Degree		2
Environmental Rating		IP20

\* Operating specifications are when installed in the conversion system base and cover plate assembly.

\* 1492-CABLE connection pins are limited to 2 A per pin. Note: Refer to the wiring diagrams for current limits for a specific configuration.

## Conversion Module Product Ratings and Capability Requirements

Catalog Number	Maximum Voltage	Current/Channel	Current/Mode	Require Fuse Holders	Maximum Fuse Rating
1492-CM1771-LD001	132V AC 47...63 Hz, 132 V DC	2A	2A		
1492-CM1771-LD002	240V AC 47...63 Hz, 240 V DC ‡	2A	2A		
1492-CM1771-LD003	132V AC 47...63 Hz, 132 V DC	2A	4A		
1492-CM1771-LD004	132V AC 47...63 Hz, 132 V DC	2A	12A		
1492-CM1771-LD005	30V DC	2A	4A		
1492-CM1771-LD006	132V AC 47...63 Hz, 132 V DC	2A	4A		
1492-CM1771-LD007	132V AC 47...63 Hz	2A	2A		
1492-CM1771-LD008F	60 V DC	2A	8A	1	10A
1492-CM1771-LD009F	32 V DC	2A	6A	4	4A
1492-CM1771-LD010F	132V AC 47...63 Hz	2A	12A	16	1.5A
1492-CM1771-LD011	240V AC 47...63 Hz, 240 V DC ‡	2A	12A		
1492-CM1771-LD012	132V AC 47...63 Hz, 132V DC	2A	12A		
1492-CM1771-LD013	240V AC 47...63 Hz ‡	2A	4A		
1492-CM1771-LD014	132V AC 47...63 Hz	2A	10A		
1492-CM1771-LA001	30V DC	2A	12A		
1492-CM1771-LA002	30V DC	2A	12A		
1492-CM1771-LA003	30V DC	2A	8A		
1492-CM1771-LA004	30V DC	2A	12A		

‡ UL listed for use at 160V AC maximum.

## Converting to ControlLogix Bulletin 1756 I/O - Application Considerations

From a functional and product features perspective; ControlLogix and Bulletin 1756 I/O are superior to the Bulletin 1771 I/O. However, there are some Bulletin 1756 I/O product differences such as in some cases lower output module current switching capability that need to be considered in your application **before** converting I/O platforms. The following drawings provide many of these key Application Considerations, along with the wiring or tough diagram from the 1771 I/O module terminal block, conversion module, pre-wired cable and up to the terminal block of the compatible Bulletin 1756 I/O module. This information must be well understood before the actual conversion. In addition, the specification section of the Bulletin 1771 and ControlLogix Bulletin 1756 I/O module installation and user manual should be compared to ensure there are no other considerations that critically impact your application.

# Bulletin 1771 to 1756 I/O Field Wiring Conversion System

## Conversion Module Installation and Application Considerations - Digital Conversion Modules

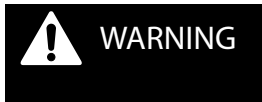

There are several key application considerations and system specifications (bottom of drawing) when using these components (conversion module, cable and input module). Read and understand these considerations before installation.

### Conversion: 1771-IAD to 1756-IA16 with 1492-CM1771-LD001

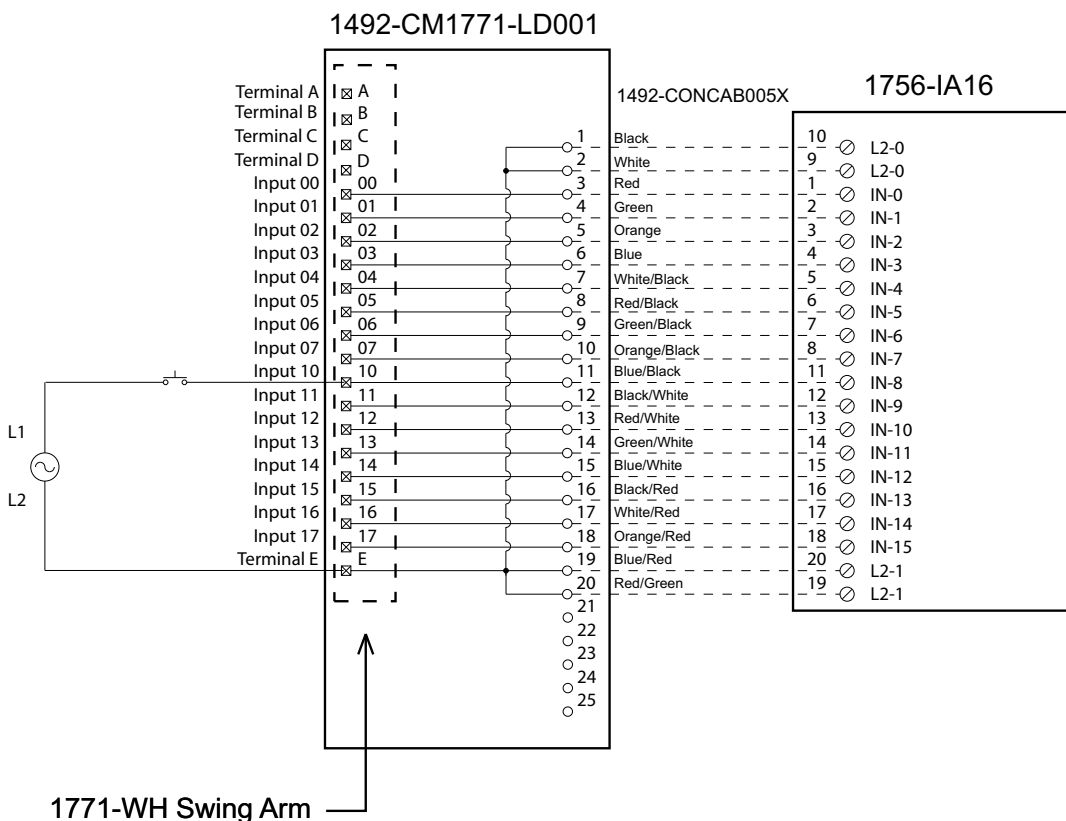

### CONVERSION MODULE INSTALLATION AND APPLICATION CONSIDERATIONS

- ① The input delay times for the 1771-IAD module versus the 1756-IA16 module are as follows:

	<b>1771-IAD</b>	<b>1756-IA16</b>
a) Off-to-On Delay	5ms (+/-3ms) @120V AC	10ms max (plus selectable filter)
b) On-to-Off Delay	25ms (+/-5ms)	8ms max (plus selectable filter)
- ② The 1771-IAD module is rated 79V to 138V AC or DC. The 1756-IA16 module is rated 74V to 132V AC. If the input source voltage is DC use a 1756-IH161 and 1492-CM1771-LD002 conversion module.
- ③ Refer to your 1771-IAD and 1756-IA16 Installation Manual wiring schematics and diagrams for more details.

41170-925 (1)

# Bulletin 1771 to 1756 I/O Field Wiring Conversion System

## Conversion Module Installation and Application Considerations - Digital Conversion Modules, continued

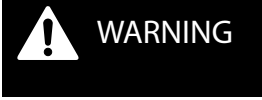

### WARNING

There are several key application considerations and system specifications (bottom of drawing) when using these components (conversion module, cable and input module). Read and understand these considerations before installation.

### Conversion: 1771-IBD to 1756-IB16 with 1492-CM1771-LD001

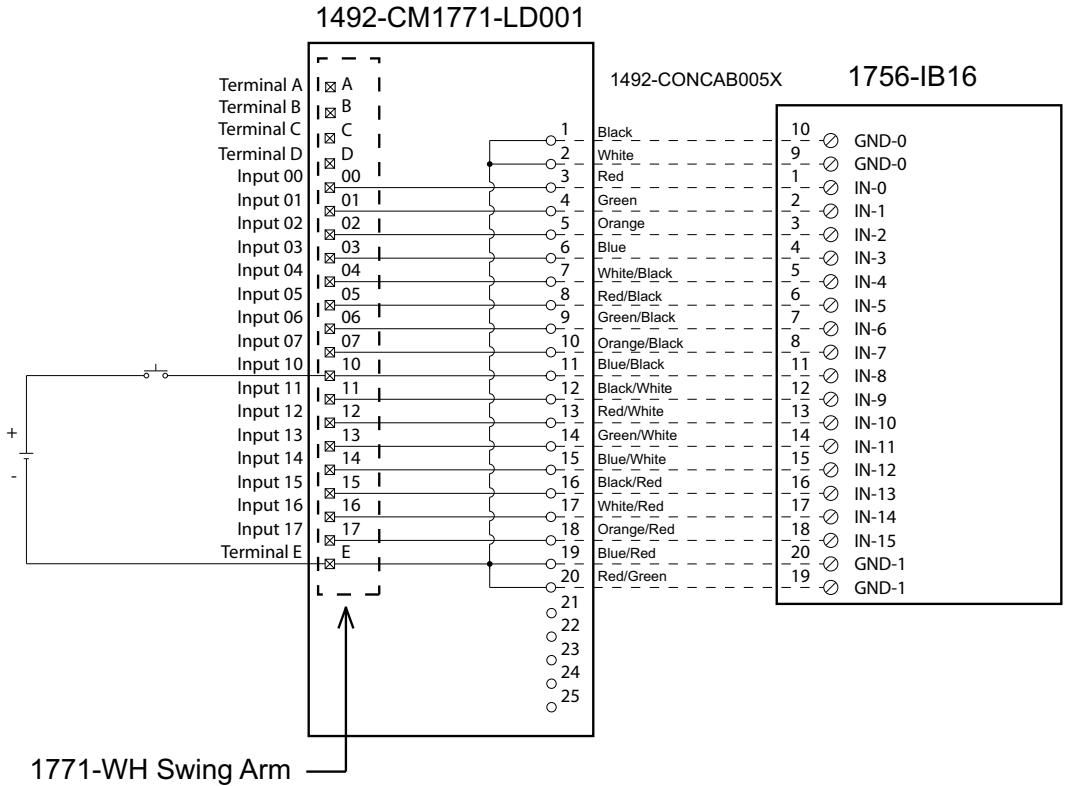

### CONVERSION MODULE INSTALLATION AND APPLICATION CONSIDERATIONS

- ① The input delay times for the 1771-IBD module versus the 1756-IB16 module are as follows:
 

	1771-IBD	1756-IB16
a) Off-to-On Delay	1ms	1ms (plus selectable filter)
b) On-to-Off Delay	1ms	2ms (plus selectable filter)
- ② Refer to your 1771-IBD and 1756-IB16 Installation Manual wiring schematics and diagrams for more details.

41170-926 (1)

# Bulletin 1771 to 1756 I/O Field Wiring Conversion System

## Conversion Module Installation and Application Considerations - Digital Conversion Modules, continued

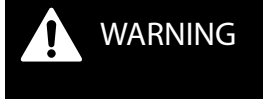

**WARNING**

There are several key application considerations and system specifications (bottom of drawing) when using these components (conversion module, cable and input module). Read and understand these considerations before installation.

### Conversion: 1771-IAD to 1756-IH16I with 1492-CM1771-LD002

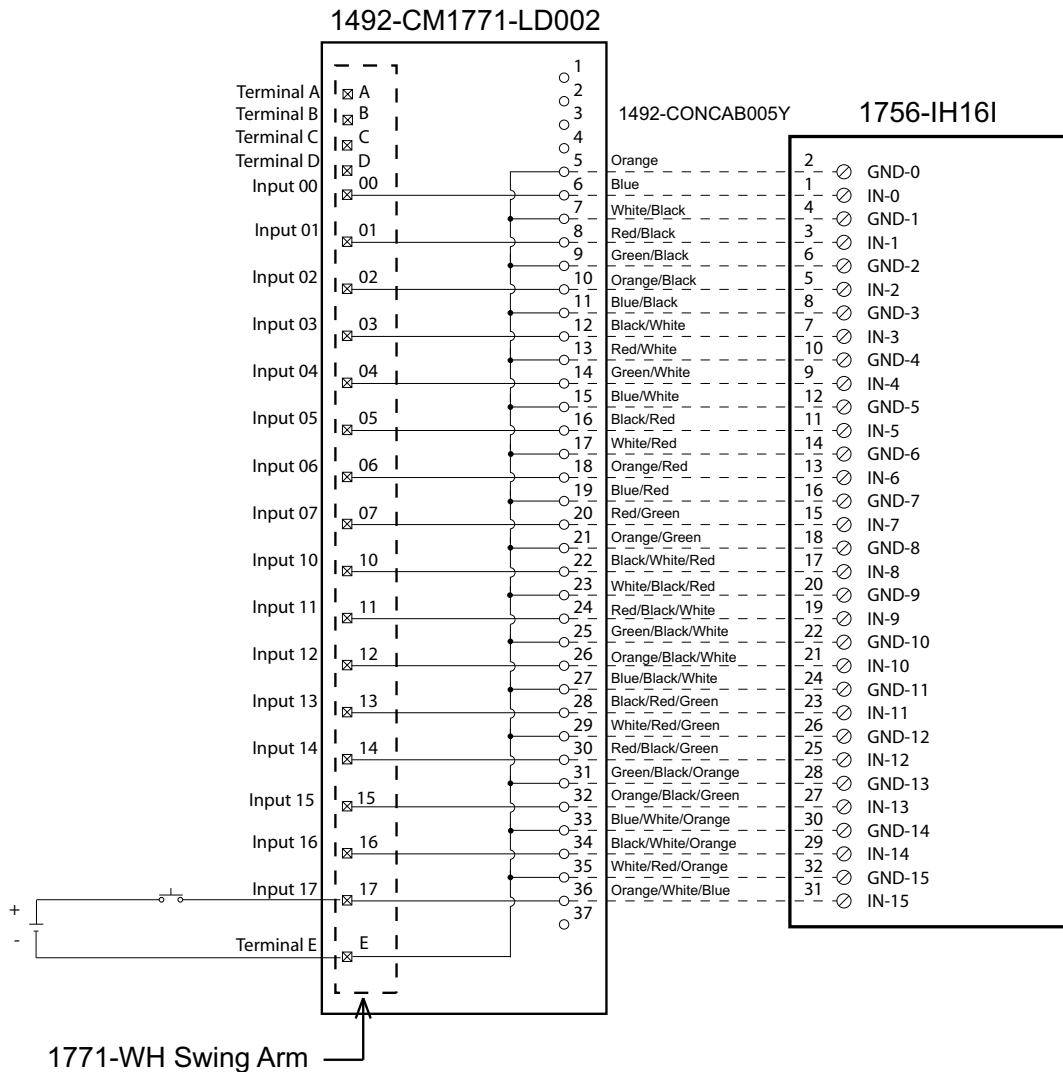

### CONVERSION MODULE INSTALLATION AND APPLICATION CONSIDERATIONS

- ① The input delay times for the 1771-IAD module versus the 1756-IH16I module are as follows:
 

	<b>1771-IAD</b>	<b>1756-IH16I</b>
a) Off-to-On Delay	3ms @120V DC	2ms (plus selectable filter)
b) On-to-Off Delay	25ms (+/-5ms)	6ms (plus selectable filter)
- ② The 1771-IAD module is rated 79V to 138V AC or DC. The 1756-IH16I module is rated 90V to 146V DC. If the input source voltage is AC use a 1756-IA16 and 1492-CM1771-LD001 conversion module.
- ③ Refer to your 1771-IAD and 1756-IH16I Installation Manual wiring schematics and diagrams for more details.

41170-927(1)

Conversion Module Installation and Application Considerations - Digital Conversion Modules, continued

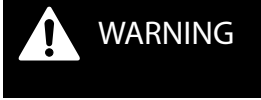

There are several key application considerations and system specifications (bottom of drawing) when using these components (conversion module, cable and input module). Read and understand these considerations before installation.

Conversion: 1771-IMD to 1756-IM16I  
with 1492-CM1771-LD002

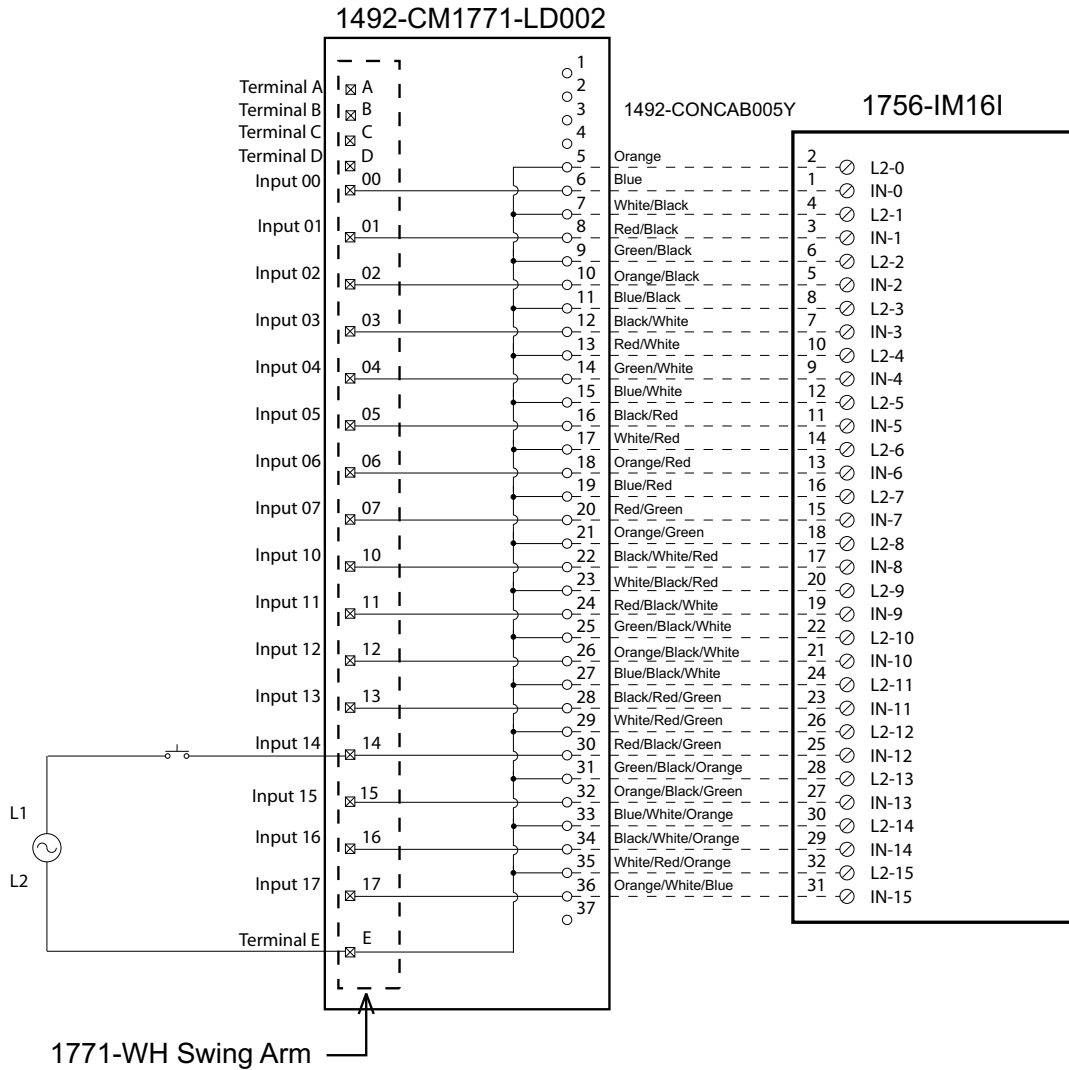

CONVERSION MODULE INSTALLATION AND APPLICATION CONSIDERATIONS

- ① The input delay times for the 1771-IMD module versus the 1756-IM16I module are as follows:
 

	1771-IMD	1756-IM16I
a) Off-to-On Delay	15ms (+/-8ms)	10ms (plus selectable filter)
b) On-to-Off Delay	172ms (+/-56ms)	8ms (plus selectable filter)
- ② The 1771-IMD module is rated 184V to 250V AC and 166V - 230V DC. The 1756-IM16I module is rated 159V to 265V AC. A 1756 input module with an equivalent DC voltage range to convert the 1771-IMD is not available.
- ③ Refer to your 1771-IMD and 1756-IM16I Installation Manual wiring schematics and diagrams for more details.

41170-928(1)

# Bulletin 1771 to 1756 I/O Field Wiring Conversion System

## Conversion Module Installation and Application Considerations - Digital Conversion Modules, continued



There are several key application considerations and system specifications (bottom of drawing) when using these components (conversion module, cable and input module). Read and understand these considerations before installation.

### Conversion: 1771-IBN to 1756-IB32 with 1492-CM1771-LD003

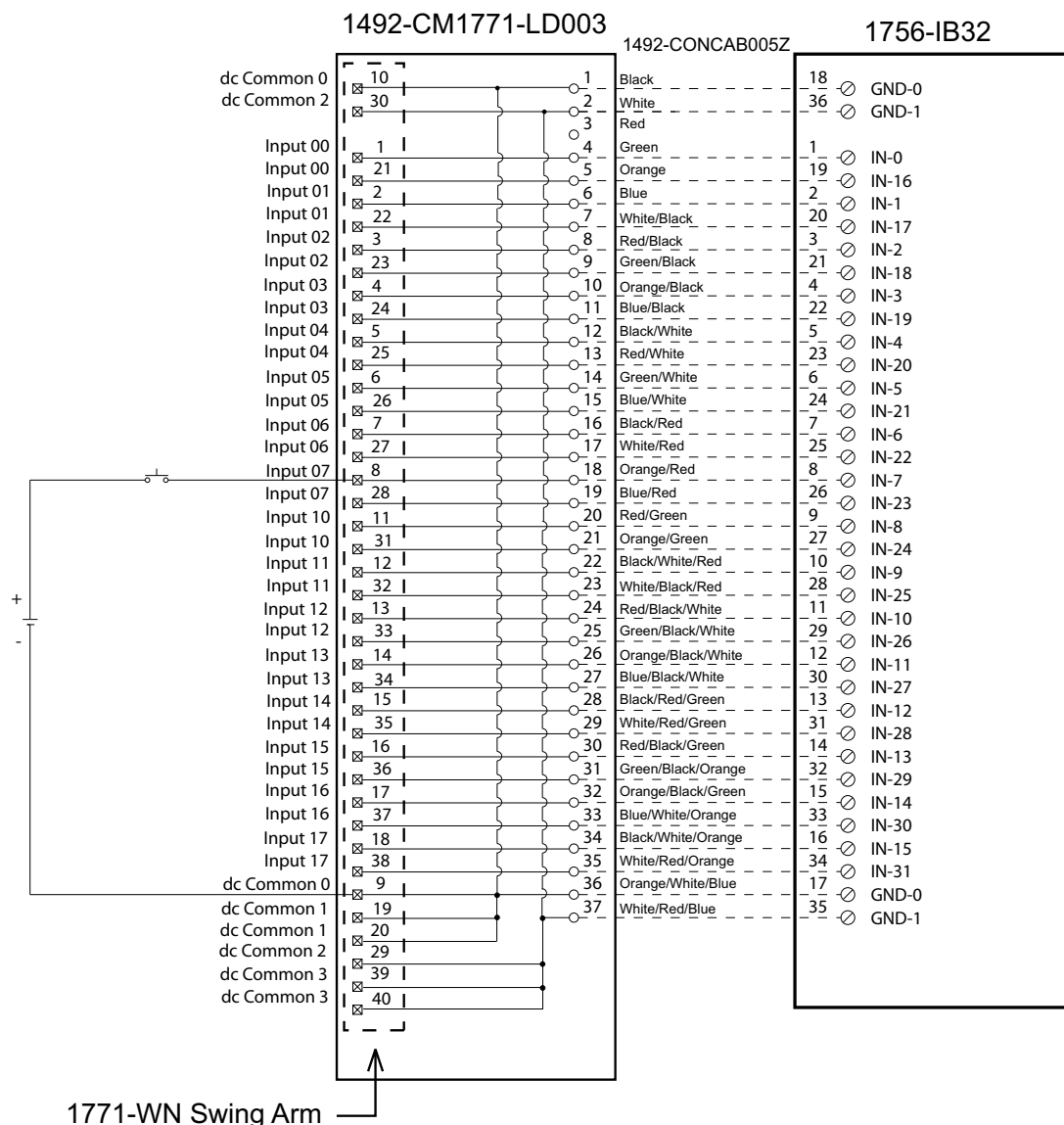

### CONVERSION MODULE INSTALLATION AND APPLICATION CONSIDERATIONS

- The input delay times for the 1771-IBN module versus the 1756-IB32 module are as follows:
 

	1771-IBN	1756-IB32
a) Off-to-On Delay	6ms (+/-2ms)	1ms (plus selectable filter)
b) On-to-Off Delay	6ms (+/-2ms)	1ms (plus selectable filter)
- The 1771-IBN has 4 groups (allowing 4 separate power supplies) and the 1756-IB32 has 2 groups. This module/cable combination ties Groups 0 & 1 from the 1771-IBN to Group 0 on the 1756-IB32 and it ties Groups 2 & 3 from the 1771-IBN to Group 1 on the 1756-IB32. Field wiring modification must be made to accommodate this if multiple supplies were used. If 4 supplies were used, 2 must be removed.
- Refer to your 1771-IBN and 1756-IB32 Installation Manual wiring schematics and diagrams for more details.

41170-929(1)

# Bulletin 1771 to 1756 I/O Field Wiring Conversion System

## Conversion Module Installation and Application Considerations - Digital Conversion Modules, continued

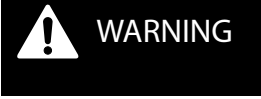

There are several key application considerations and system specifications (bottom of drawing) when using these components (conversion module, cable and input module). Read and understand these considerations before installation.

### Conversion: 1771-IAN to 1756-IA32 with 1492-CM1771-LD003

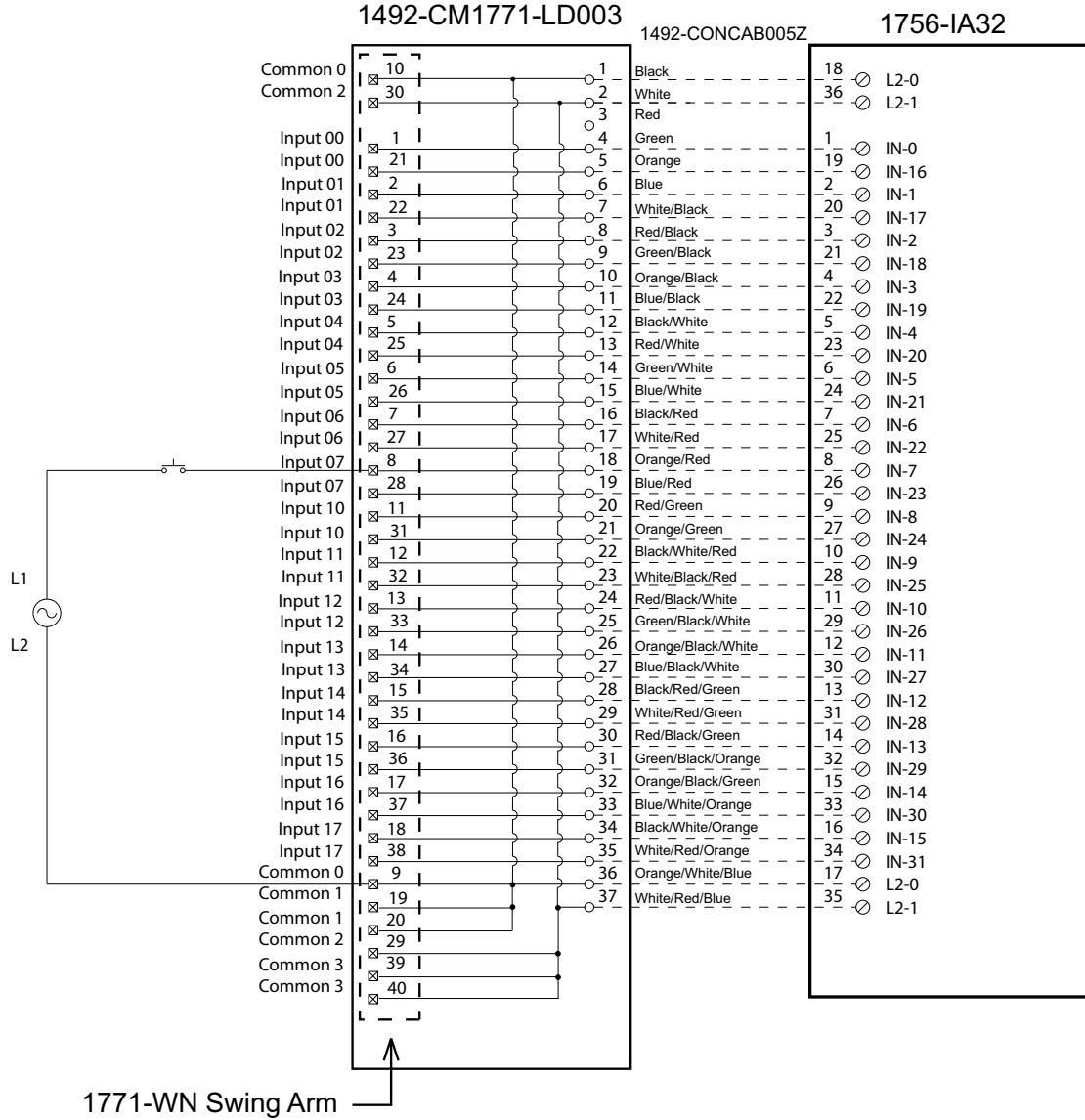

### CONVERSION MODULE INSTALLATION AND APPLICATION CONSIDERATIONS

① The input delay times for the 1771-IAN module versus the 1756-IA32 module are as follows:

	1771-IAN	1756-IA32
a) Off-to-On Delay	10ms (+/-7ms)	10ms max (plus selectable filter)
b) On-to-Off Delay	20ms (+/-15ms)	8ms max (plus selectable filter)

② The 1771-IAN has 4 groups (allowing 4 separate power supplies) and the 1756-IA32 has 2 groups. This module/cable combination ties Groups 0 & 1 from the 1771-IAN to Group 0 on the 1756-IA32 and it ties Groups 2 & 3 from the 1771-IAN to Group 1 on the 1756-IA32. Field wiring modification must be made to accommodate this if multiple supplies were used. If 4 supplies were used, 2 must be removed.

③ Refer to your 1771-IAN and 1756-IA32 Installation Manual wiring schematics and diagrams for more details.

41170-930(1)



# Bulletin 1771 to 1756 I/O Field Wiring Conversion System

## Conversion Module Installation and Application Considerations - Digital Conversion Modules, continued



There are several key application considerations and system specifications (bottom of drawing) when using these components (conversion module, cable and input module). Read and understand these considerations before installation.

### Conversion: 1771-ID16 to 1756-IA16I with 1492-CM1771-LD004

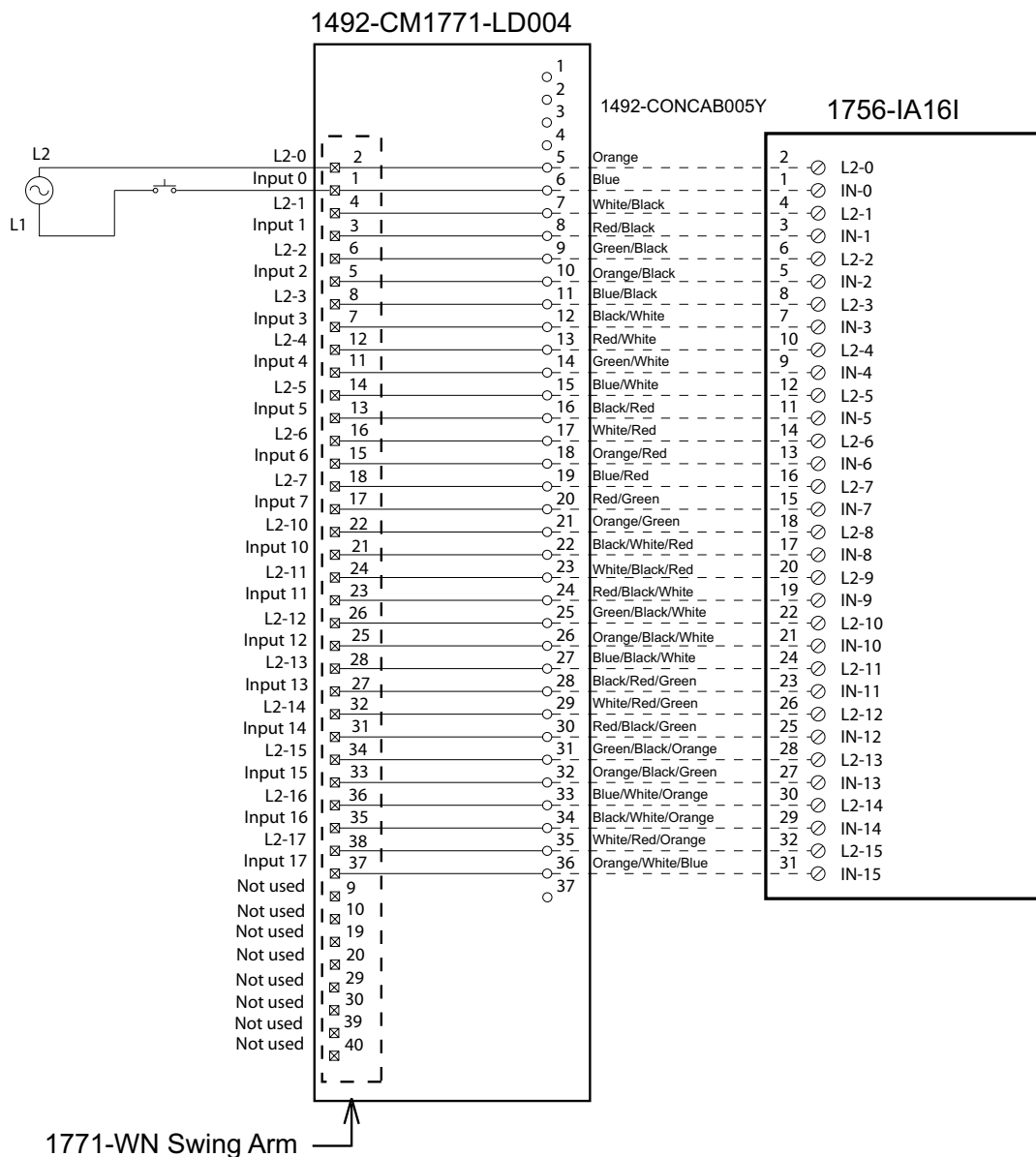

### CONVERSION MODULE INSTALLATION AND APPLICATION CONSIDERATIONS

- ① The input delay times for the 1771-ID16 module versus the 1756-IA16I module are as follows:
 

	<b>1771-ID16</b>	<b>1756-IA16I</b>
a) Off-to-On Delay	0.57ms	10ms max (plus selectable filter)
b) On-to-Off Delay	9ms or 18ms (selectable)	8ms max (plus selectable filter)
- ② The 1771-ID16 module is rated 74V to 138V AC and 105V to 138V DC. The 1756-IA16I is rated 79V to 132V AC. If the input source voltage is DC use a 1756-IH16I with this conversion module.
- ③ Refer to your 1771-ID16 and 1756-IA16I Installation Manual wiring schematics and diagrams for more details. 41170-931 (1)

Conversion Module Installation and Application Considerations - Digital Conversion Modules, continued



There are several key application considerations and system specifications (bottom of drawing) when using these components (conversion module, cable and input module). Read and understand these considerations before installation.

Conversion: 1771-ID16 to 1756-IH16I  
with 1492-CM1771-LD004

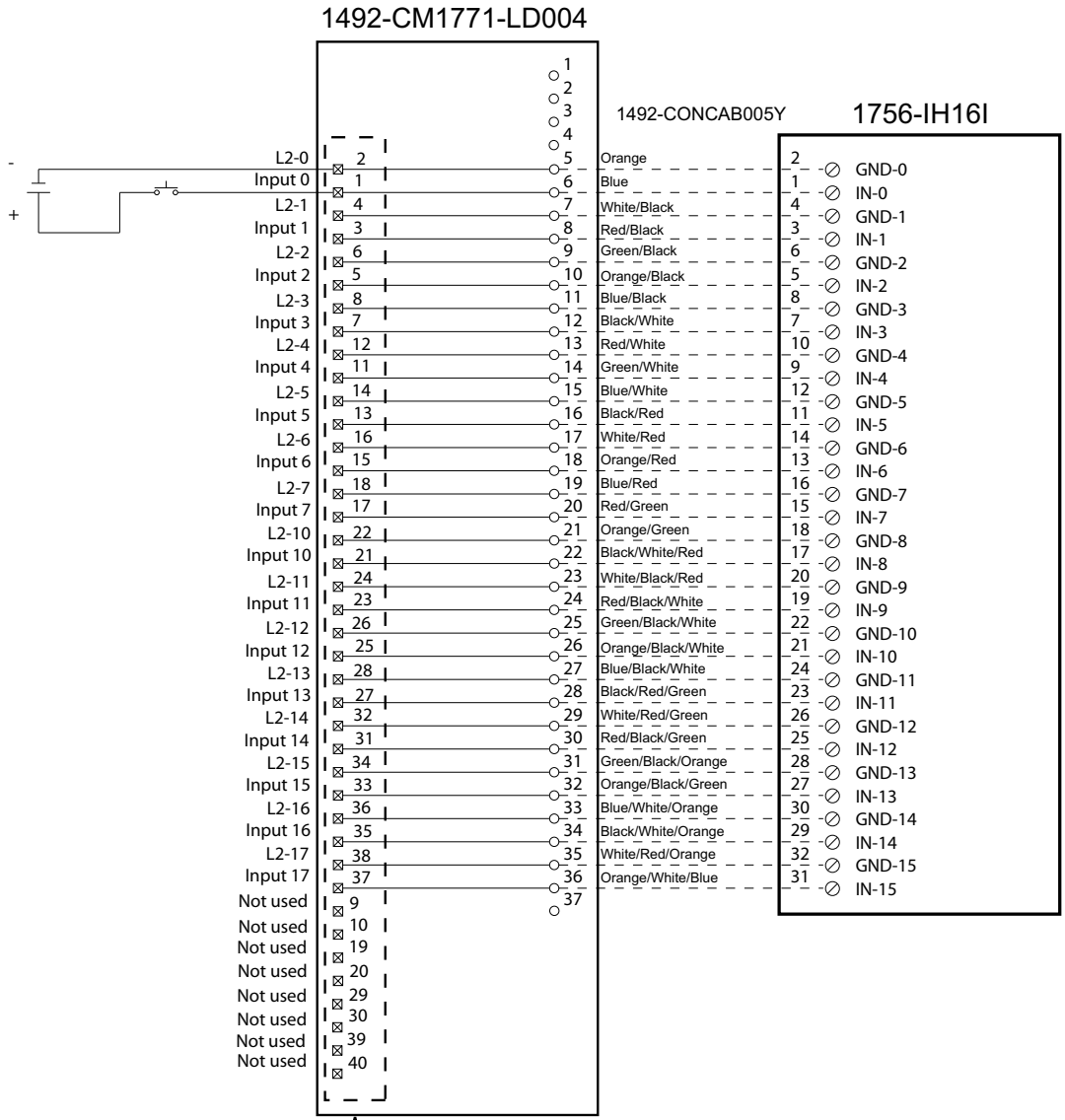

1771-WN Swing Arm

CONVERSION MODULE INSTALLATION AND APPLICATION CONSIDERATIONS

- ① The input delay times for the 1771-ID16 module versus the 1756-IH16I module are as follows:
 

	1771-ID16	1756-IH16I
a) Off-to-On Delay	0.57ms	2ms (plus selectable filter)
b) On-to-Off Delay	18ms (selectable)	6ms (plus selectable filter)
- ② The 1771-ID16 module is rated 74V to 138V AC and 105V to 138V DC. The 1756-IH16I is rated 90V to 146V DC. If the input source voltage is AC use a 1756-IA16I with this conversion module.
- ③ Refer to your 1771-ID16 and 1756-IH16I Installation Manual wiring schematics and diagrams for more details.

41170-932 (1)

# Bulletin 1771 to 1756 I/O Field Wiring Conversion System

## Conversion Module Installation and Application Considerations - Digital Conversion Modules, continued



**WARNING**

There are several key application considerations and system specifications (bottom of drawing) when using these components (conversion module, cable and input module). Read and understand these considerations before installation.

### Conversion: 1771-IQ16 to 1756-IB16I with 1492-CM1771-LD004

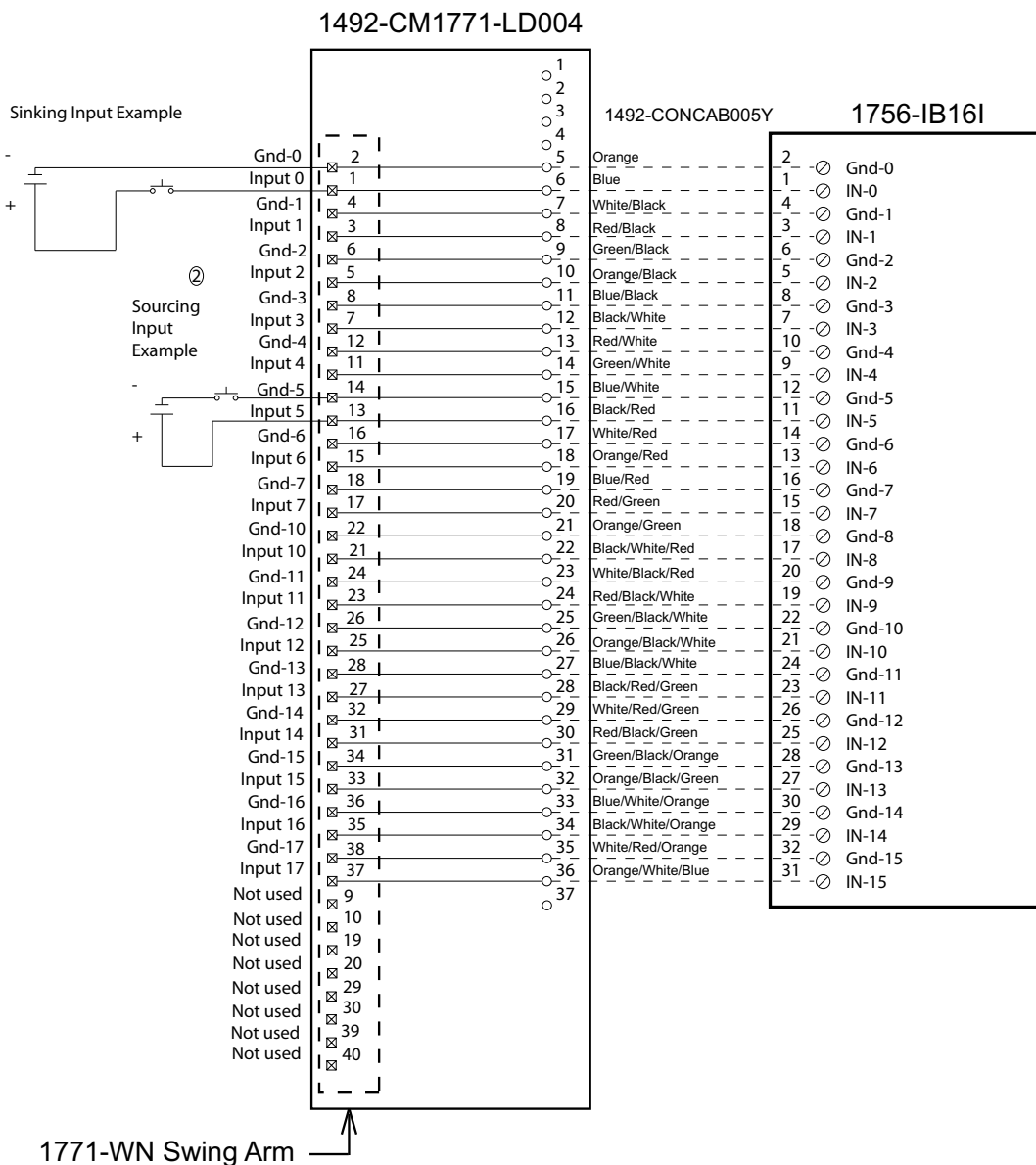

### CONVERSION MODULE INSTALLATION AND APPLICATION CONSIDERATIONS

- ① The input delay times for the 1771-IQ16 module versus the 1756-IB16I module are as follows:

	<b>1771-IQ16</b>	<b>1756-IB16I</b>
a) Off-to-On Delay	.57ms	1ms max (plus selectable filter)
b) On-to-Off Delay	.57ms	4ms max (plus selectable filter)
- ② Both the 1771-IQ16 and 1756-IB16I allow operation with sourcing inputs. Refer to Installation Instructions for details.
- ③ Refer to your 1771-IQ16 and 1756-IB16I Installation Manual wiring schematics and diagrams for more details.

41170-933 (1)

Conversion Module Installation and Application Considerations - Digital Conversion Modules, continued



There are several key application considerations and system specifications (bottom of drawing) when using these components (conversion module, cable and input module). Read and understand these considerations before installation.

Conversion: 1771-IVN to 1756-IV32  
with 1492-CM1771-LD005

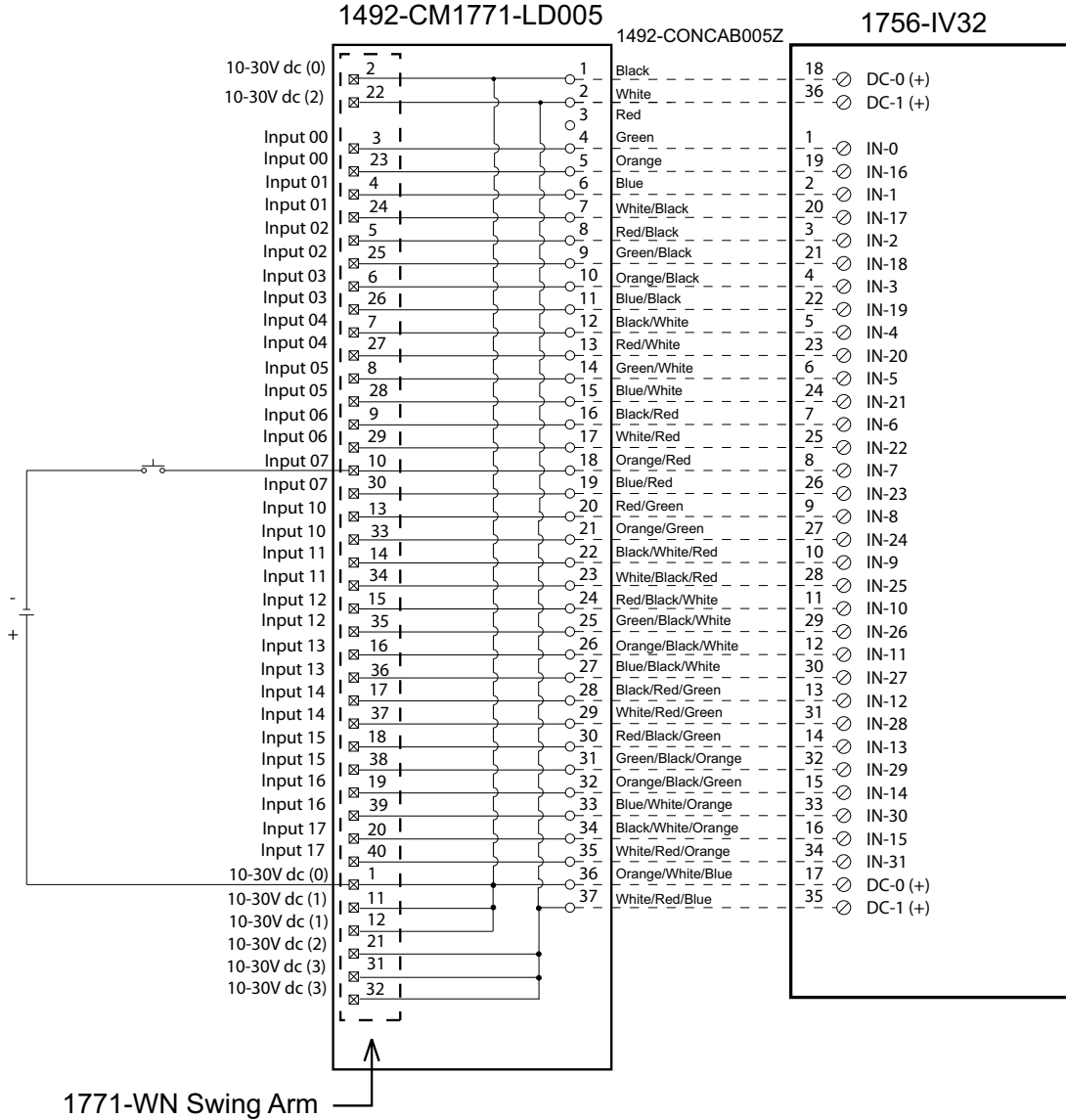

CONVERSION MODULE INSTALLATION AND APPLICATION CONSIDERATIONS

- ① The input delay times for the 1771-IVN module versus the 1756-IV32 module are as follows:
 

	1771-IVN	1756-IV32
a) Off-to-On Delay	6ms (+/-2ms)	1ms (plus selectable filter)
b) On-to-Off Delay	6ms (+/-2ms)	2ms (plus selectable filter)
- ② The 1771-IVN has 4 groups (allowing 4 separate power supplies) and the 1756-IV32 has 2 groups. This module/cable combination ties Groups 0 & 1 from the 1771-IVN to Group 0 on the 1756-IV32 and it ties Groups 2 & 3 from the 1771-IVN to Group 1 on the 1756-IV32. Field wiring modification must be made to accommodate this if multiple supplies were used. If 4 supplies were used, 2 must be removed.
- ③ Refer to your 1771-IVN and 1756-IV32 Installation Manual wiring schematics and diagrams for more details.

41170-934(1)

# Bulletin 1771 to 1756 I/O Field Wiring Conversion System

## Conversion Module Installation and Application Considerations - Digital Conversion Modules, continued



There are several key application considerations and system specifications (bottom of drawing) when using these components (conversion module, cable and output module). Read and understand these considerations before installation. In addition, refer to the current draw requirements of the existing loads for this configuration to ensure they are within the current ratings of the 1756 output module.

### Conversion: 1771-OAD to 1756-OA16 with 1492-CM1771-LD006

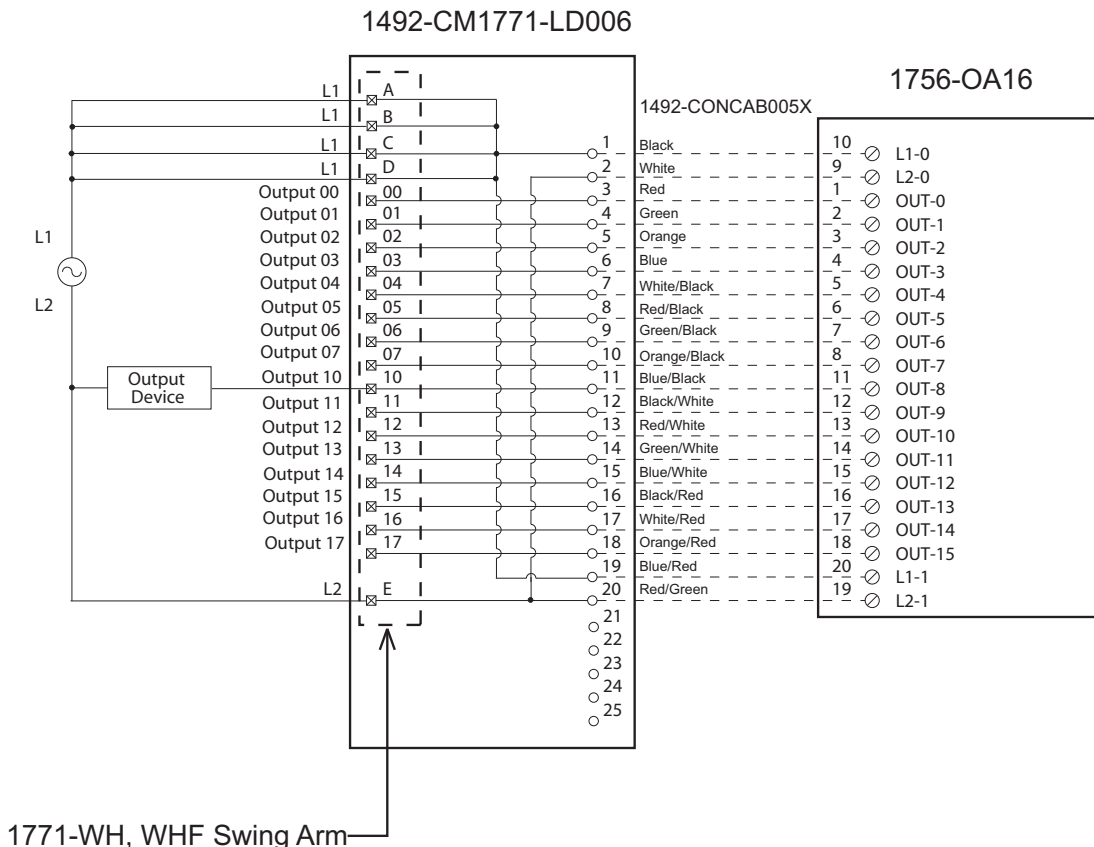

### CONVERSION MODULE INSTALLATION AND APPLICATION CONSIDERATIONS

- ① The 1771-OAD module output current limits versus 1756-OA16 limits are as follows:
 

	1771-OAD	1756-OA16 w/ 1492-CONCAB005X
a) Current/Point	2A	0.5A
b) Current/Module	8A	4A
c) Surge Current/Point	25A for 100ms	5A for 43ms
- ② The L2 terminal (Terminal E) on the 1771-OAD module was an optional connection, but it is required for the 1756-OA16. This connection must be added if it was not connected.
- ③ The 1492-CONCAB005X is limited to 3A per pin.
- ④ The 1771-OAD is rated 10V to 138V AC. The 1756-OA16 is rated 74V to 265V AC.
- ⑤ Refer to your 1771-OAD and 1756-OA16 Installation Manual wiring schematics and diagrams for more details. Ensure 1756 output module ratings are not exceeded.

41170-935 (0)

Conversion Module Installation and Application Considerations - Digital Conversion Modules, continued



There are several key application considerations and system specifications (bottom of drawing) when using these components (conversion module, cable and output module). Read and understand these considerations before installation. In addition, refer to the current draw requirements of the existing loads for this configuration to ensure they are within the current ratings of the 1756 output module.

Conversion: 1771-OBD to 1756-OB16E  
with 1492-CM1771-LD006

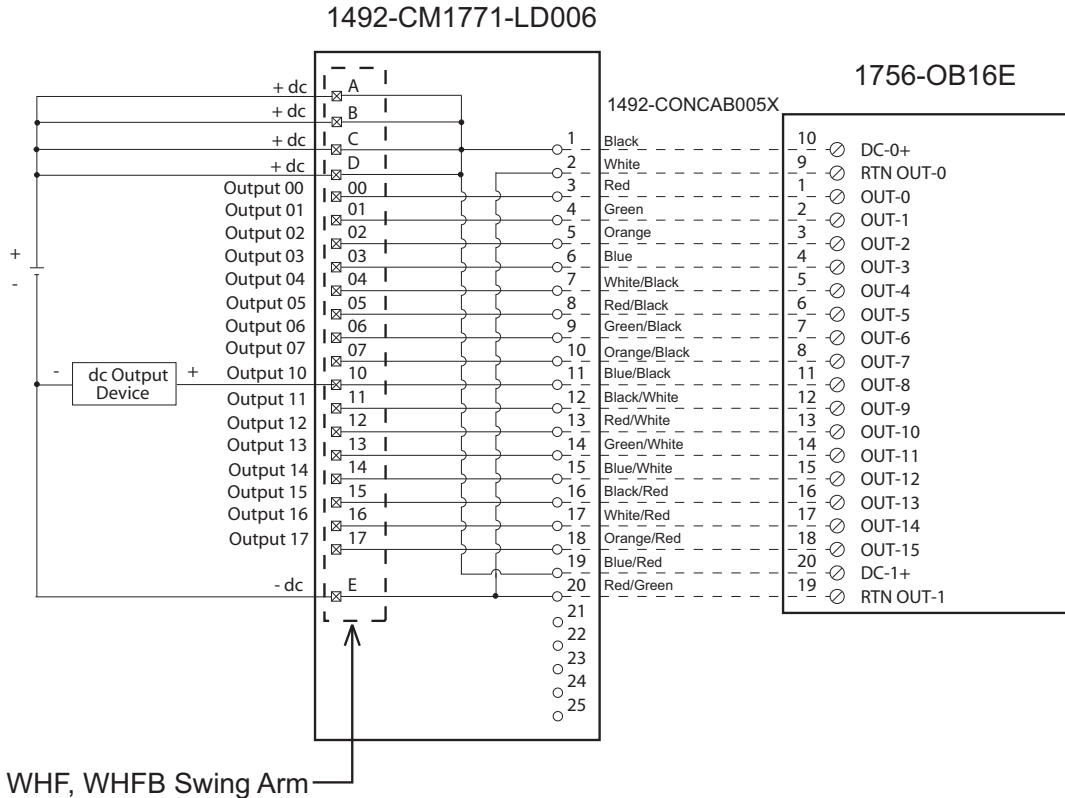

CONVERSION MODULE INSTALLATION AND APPLICATION CONSIDERATIONS

- ① The 1771-OBD module output current limits versus 1756-OB16E limits are as follows:
 

	1771-OBD	1756-OB16E w/ 1492-CONCAB005X
a) Current/Point	2A	1A
b) Current/Module	8A	4A
c) Surge Current/Point	4A for 10ms	2A for 10ms
- ② The 1771-OBD has a single 10A, 250V rectifier fuse (1/4 x 1 1/4 inch). The 1756-OB16E is electronically fused per group. Refer to the 1756-OB16E Installation Manual for details on electronic fusing.
- ③ The 1492-CONCAB005X is limited to 3A per pin.
- ④ The 1771-OBD is rated 10V to 60V DC. The 1756-OB16E is rated 10V to 31.2V DC. If the load source voltage is greater than 30V DC, then use the 1756-OC8 with the 1492-CM1771-LD008F conversion module.
- ⑤ Refer to your 1771-OBD and 1756-OB16E Installation Manual wiring schematics and diagrams for more details. Ensure 1756 output module ratings are not exceeded.

41170-936 (0)

# Bulletin 1771 to 1756 I/O Field Wiring Conversion System

## Conversion Module Installation and Application Considerations - Digital Conversion Modules, continued

Conversion: 1771-IA or 1771-IA2 to 1756-IA16 with 1492-CM1771-LD007



**WARNING**

There are several key application considerations and system specifications (bottom of drawing) when using these components (conversion module, cable and output module). Read and understand these considerations before installation.

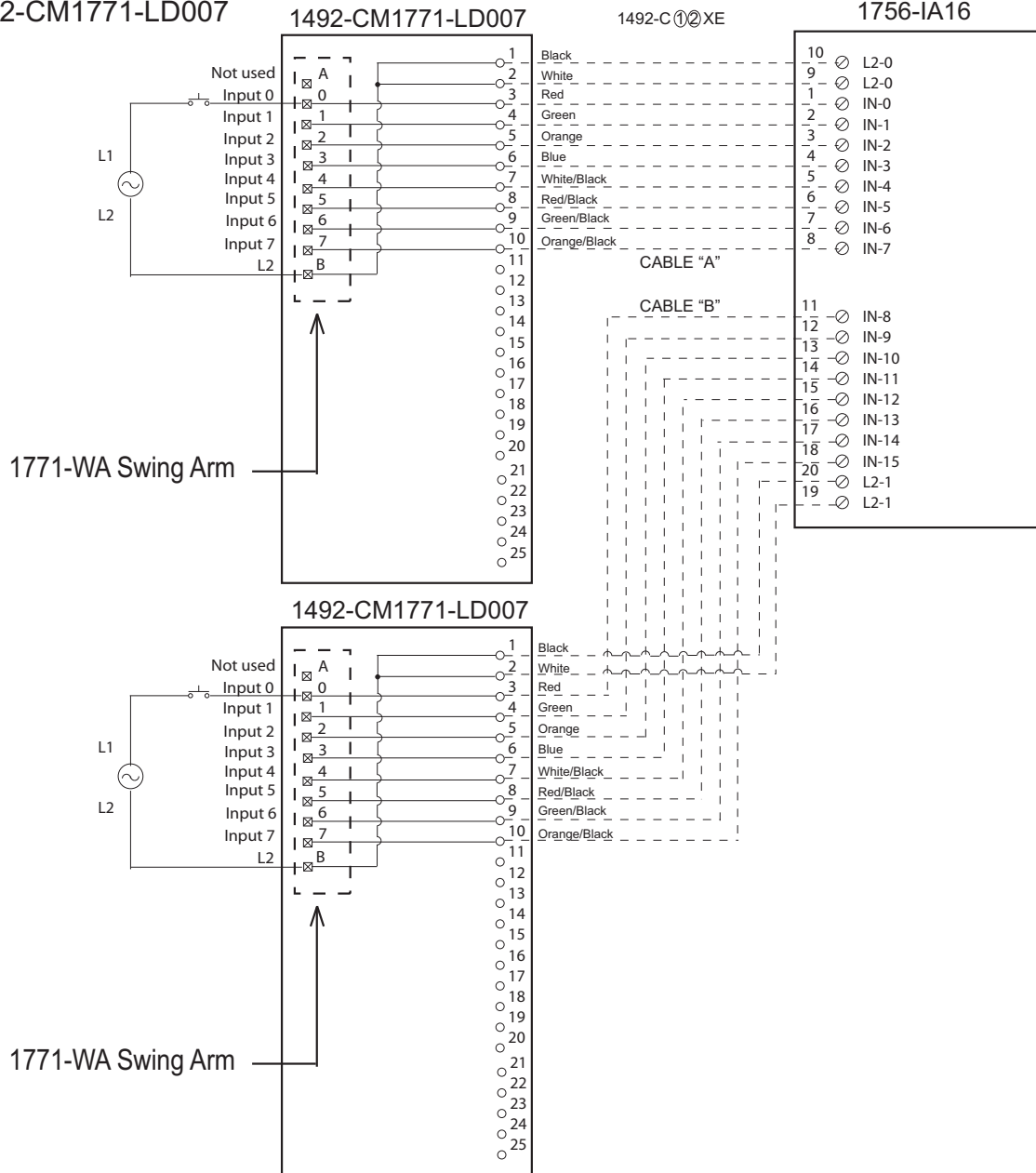

### CONVERSION MODULE INSTALLATION AND APPLICATION CONSIDERATIONS

- ①② This Bul. 1492 cable consists of 2 separate cables (cable "A" and "B") wired to one 1756-IA16 RTB. Each cable can be either 0.5M or 1.0M (005=0.5M, 010=1.0M). Ensure that cable A and cable B are connected to the correct module in the conversion.
- ③ The input delay times for the 1771-IA module versus the 1756-IA16 module are as follows:
 

	1771-IA	1756-IA16
a) Off-to-On Delay	24ms (+/-10ms)	10ms max (plus selectable filter)
b) On-to-Off Delay	24ms (+/-10ms)	8ms max (plus selectable filter)
- ④ The 1771-IA module is rated 87V to 138V AC and 97V to 138V DC. The 1756-IA16 module is rated 79V to 132V AC only.
- ⑤ Refer to your 1771-IA and 1756-IA16 Installation Manual wiring schematics and diagrams for more details.

41170-952 (0)

Conversion Module Installation and Application Considerations - Digital Conversion Modules, continued



**WARNING**

There are several key application considerations and system specifications (bottom of drawing) when using these components (conversion module, cable and output module). Read and understand these considerations before installation. In addition, refer to the current draw requirements of the existing loads for this configuration to ensure they are within the current ratings of the 1756 output module.

Conversion: 1771-OBD to 1756-OC8 Qty. 2  
with 1492-CM1771-LD008F

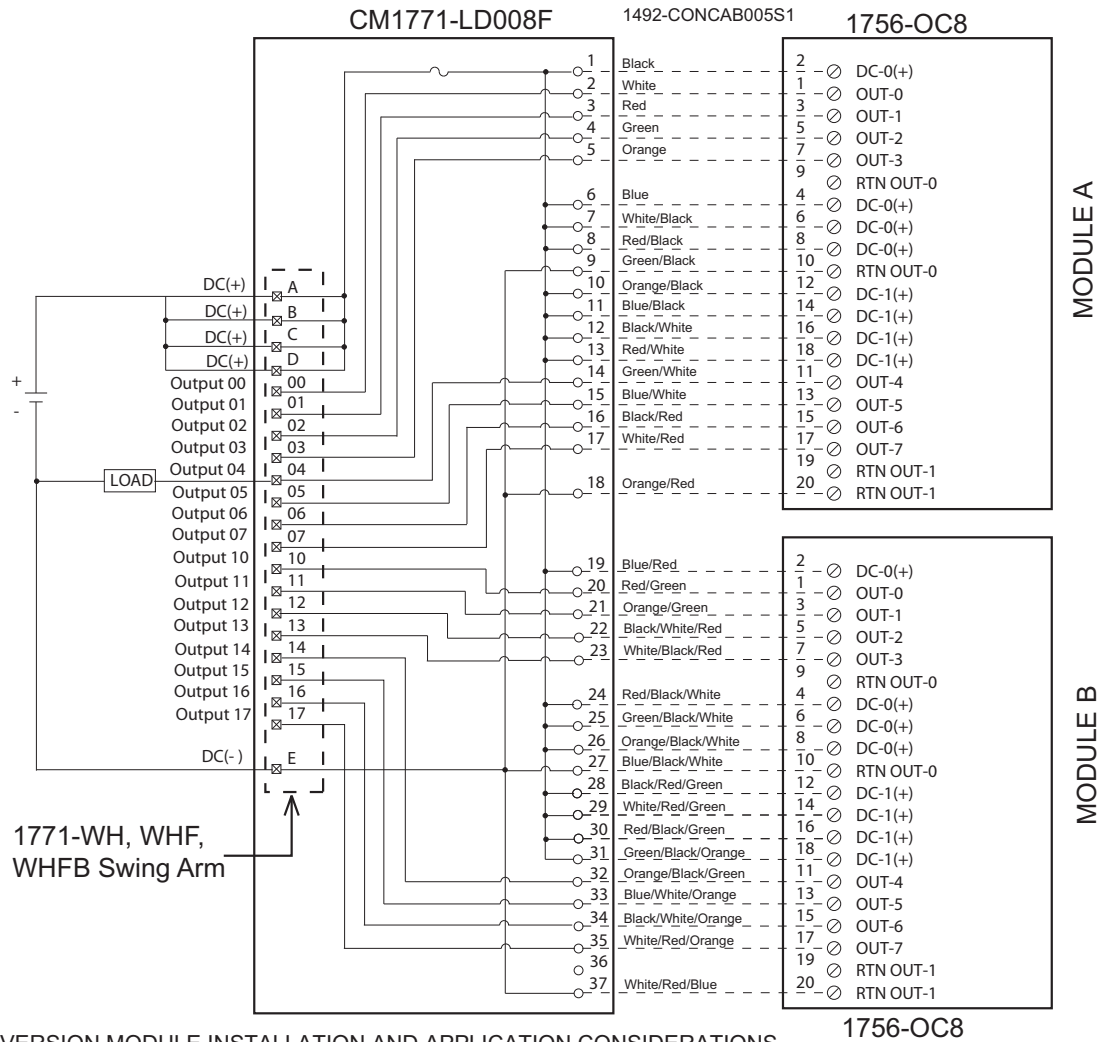

CONVERSION MODULE INSTALLATION AND APPLICATION CONSIDERATIONS

- ① The 1771-OBD module output current limits versus 1756-OC8 limits are as follows:
 

	1771-OBD	1756-OC8 w/ 1492-CONCAB005S1
a) Current/Point	2A	2A
b) Current/Module	8A	8A
c) Surge Current/Point	4A for 10ms	4A for 10ms
- ② The 1771-OBD has a single 10A, 250V rectifier fuse (1/4 x 1 1/4 inch). The 1756-OC8 is NOT fused, as such a 2AG fuse clip and 10A fuse is provided on the 1492-CM1771-LD008F conversion module.
- ③ The 1492-CONCAB005S1 is limited to 3A per pin.
- ④ The 1771-OBD is rated 10V to 60V DC. The 1756-OC8 is rated 30V to 60V DC. If the load source voltage is less than 30V DC, then use the 1756-OB16E with the 1492-CM1771-LD006 conversion module.
- ⑤ This configuration uses two (2) 1756-OC8 output modules to replace a single 1771-OBD output module. This may require the use of a larger 1756 I/O chassis and conversion mounting assembly. Ensure there is sufficient panel space to allow for this possibility.
- ⑥ Refer to your 1771-OBD and 1756-OC8 Installation Manual wiring schematics and diagrams for more details. Ensure 1756 output module ratings are not exceeded.

41170-937 (0)

# Bulletin 1771 to 1756 I/O Field Wiring Conversion System

## Conversion Module Installation and Application Considerations - Digital Conversion Modules, continued



**WARNING**

There are several key application considerations and system specifications (bottom of drawing) when using these components (conversion module, cable and output module). Read and understand these considerations before installation. In addition, refer to the current draw requirements of the existing loads for this configuration to ensure they are within the current ratings of the 1756 output module.

**Conversion: 1771-OBN to 1756-OB32 with 1492-CM1771-LD009F**  
**1492-CM1771-LD009F**

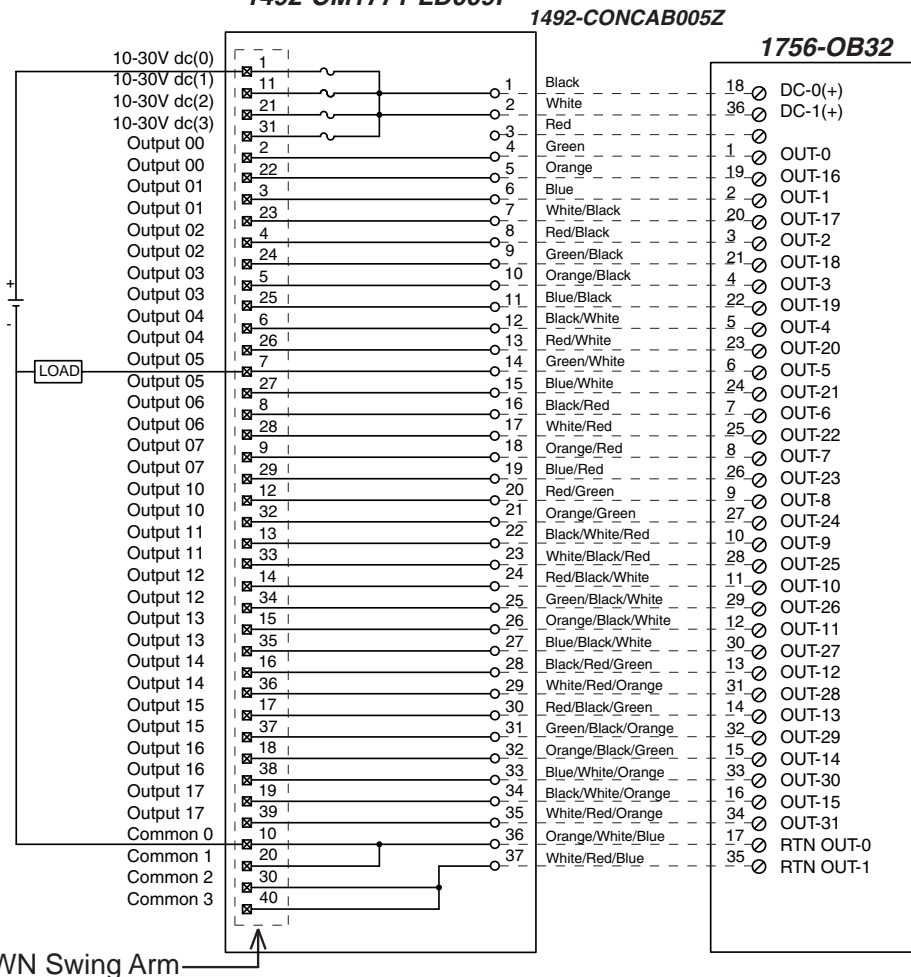

**Conversion Module Installation and Application Considerations**

① The 1771-OBN module output current limits versus 1756-OB32 limits are as follows:

	1771-OBN	1756-OB32w/1492-CONCAB005Z
a) Current/Point	0.5A	0.35A @ 60°C
b) Current/Module	8A	6A @ 60°C
c) Surge Current/Point	2A for 10ms	1A for 10ms

② The 1771-OBN has four (4) 4A, 250V rectifier fuses. The 1756-OB32 is NOT fused, as such four (4) 2AG fuse clips and 4A fuses are provided on the 1492-CM1771-LD009F conversion module.

③ The 1492-CONCAB005Z is limited to 3A per pin.

④ The 1771-OBN has 4 groups (allowing 4 separate power supplies) and the 1756-OB32 has 2 groups. This module/cable combination ties Groups 0 & 1 from the 1771-OBN to Group 0 on the 1756-OB32 and Groups 2 & 3 from the 1771-OBN to Group 1 on the 1756-OB32. Field wiring modification must be made to accommodate this if multiple supplies were used. If 4 supplies were used, 2 must be removed.

⑤ Refer to your 1771-OBN and 1756-OB32 Installation Manual wiring schematics and diagrams for more details. Ensure 1756 output module ratings are not exceeded.

[Reference Doc: 41170-938 (Version 00)]

# Bulletin 1771 to 1756 I/O Field Wiring Conversion System

## Conversion Module Installation and Application Considerations - Digital Conversion Modules, continued

**WARNING**

There are several key application considerations and system specifications (bottom of drawing) when using these components (conversion module, cable and output module). Read and understand these considerations before installation. In addition, refer to the current draw requirements of the existing loads for this configuration to ensure they are within the current ratings of the 1756 output module.

**Conversion: 1771-OD16 to 1756-OA16I with 1492-CM1771-LD010F**  
**1492-CM1771-LD010F**

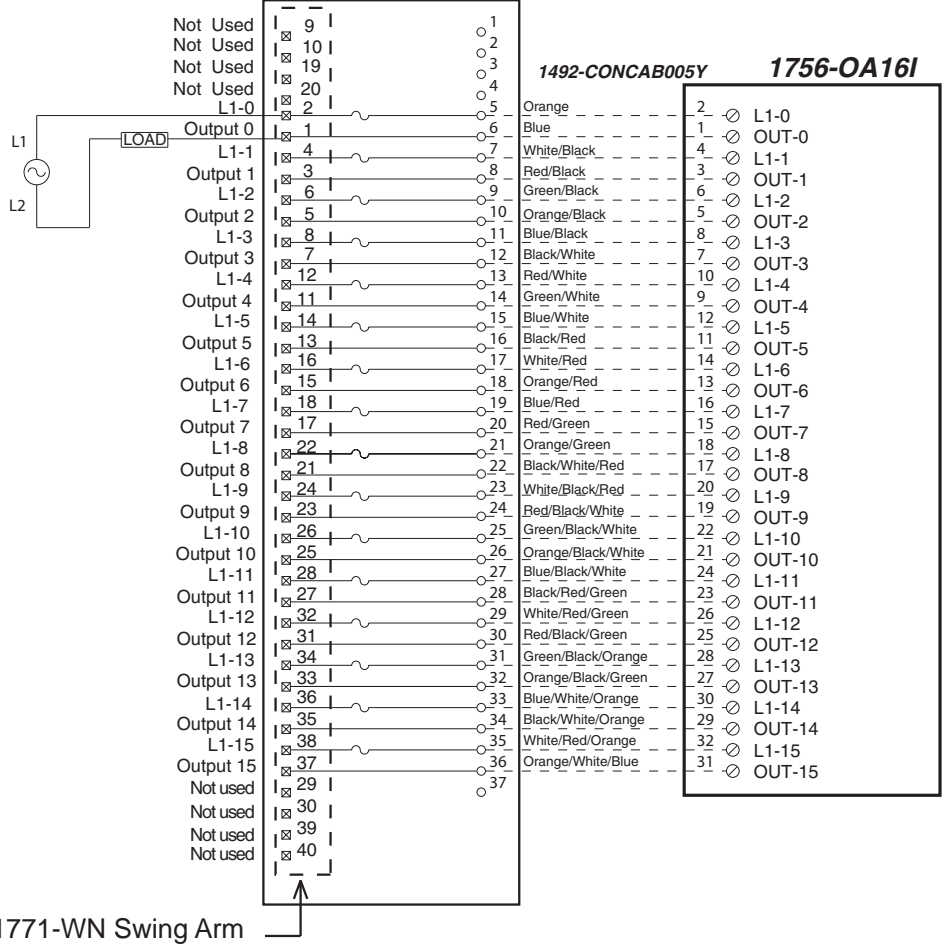

**Conversion Module Installation and Application Considerations**

- ① The 1771-OD16 module output current limits versus 1756-OA16I limits are as follows:
 

	<b>1771-OD16</b>	<b>1756-OA16Iw/1492-CONCAB005Y</b>
a) Current/Point	2A	1A
b) Current/Module	8A	4A
b) Surge Current/Point	20A for 100ms	20A for 43ms
- ② The 1771-OD16 has sixteen (16) 3A ,250V recifier fuses. The 1756-OA16I is NOT fused,as such sixteen (16) 2AG fuse clips are provided on the 1492-CM1771-LD010F conversion module. Max fuse rating is 1.5A based on 1756-OA16I.
- ③ The 1492-CONCAB005Y is limited to 3A per pin.
- ④ The 1771-OD16 is rated 74V to 138V AC and 105V to 138V DC. The 1756-OA16I is rated 74V to 265V AC. A1756 isolated output module with an equivalent DC voltage range to convert the1771 -OD16 is not available.
- ⑤ Refer to your 1771-OD16 and 1756-OA16I Installation Manual wiring schematics and diagrams for more details. Ensure 1756 output module rating are not exceeded. [Reference Doc: 41170-939 (Version 00)]

# Bulletin 1771 to 1756 I/O Field Wiring Conversion System

## Conversion Module Installation and Application Considerations - Digital Conversion Modules, continued



**WARNING**

There are several key application considerations and system specifications (bottom of drawing) when using these components (conversion module, cable and output module). Read and understand these considerations before installation. In addition, refer to the current draw requirements of the existing loads for this configuration to ensure they are within the current ratings of the 1756 output module.

**Conversion: 1771-OW16 to 1756-OW16I with 1492-CM1771-LD011**

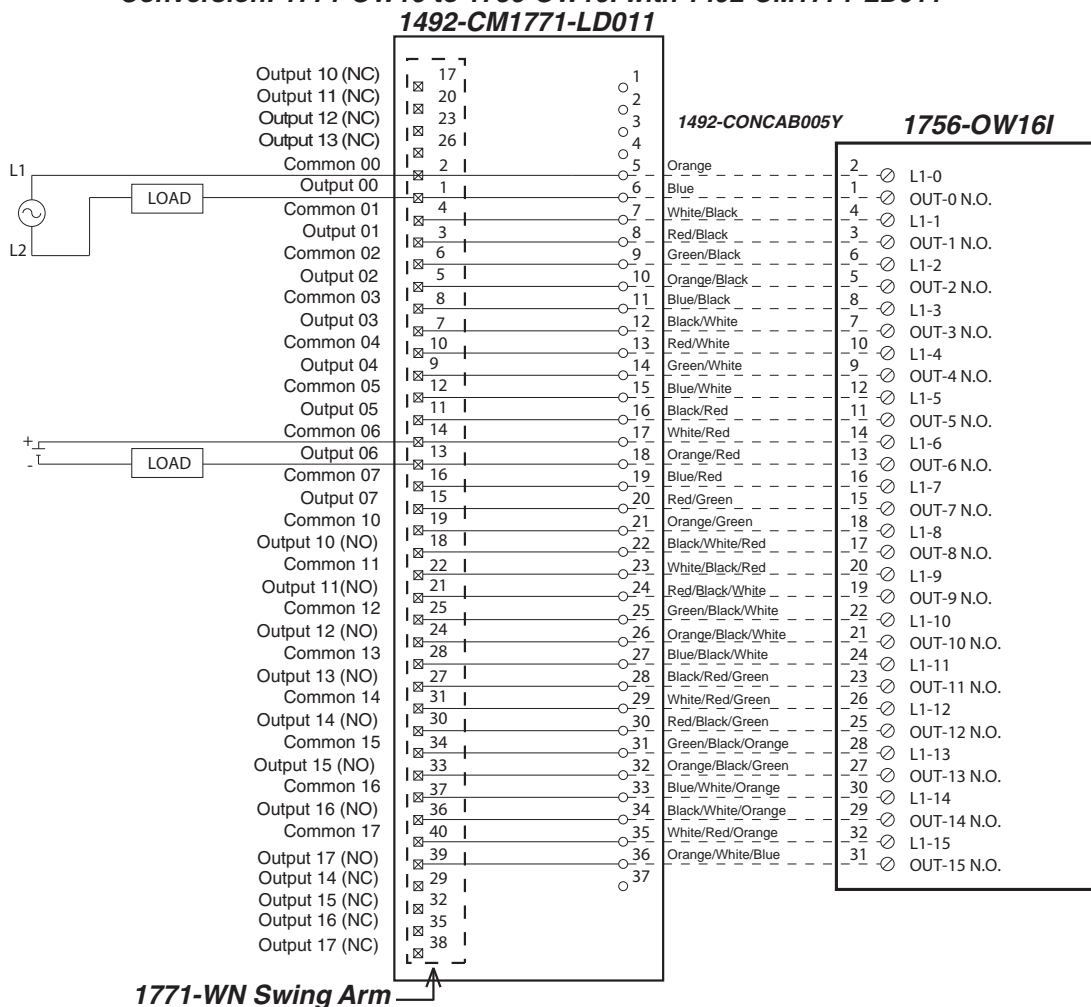

1771-WN Swing Arm

**Conversion Module Installation and Application Considerations**

① The 1771-OW16 module output resistive current limits versus 1756-OW16I limits are as follows:

	<b>1771-OW16</b>	<b>1756-OW16I w/ 1492-CONCAB005Y</b>
a) Current/Point	2A @ 250V AC 2A @ 30V DC 0.3A @ 150V DC	2A @ 240V AC 2A @ 30V DC 0.25A @ 125V AC

② The 1492-CONCAB005Y is limited to 3A per pin.

③ The 1771-OW16 has N.O. and N.C. relay contact outputs. The 1756-OW16I has N.O. relay contact outputs only. The conversion module does not convert the N.C. to N.O. contacts. If the 1771-OW16 N.C. outputs were being used, the installer must rewire the 1771-WN swing arm and move the N.C. wires to the N.O. output terminals. In addition, the control Logix programming will need to be changed to simulate a N.C. relay with this output.

④ Refer to your 1771-OW16 and 1756-OW16I Installation Manual wiring schematics and diagrams for more details.

Ensure 1756 output module ratings are not exceeded.

Reference Doc: 41170-940 (Version 00)]

Conversion Module Installation and Application Considerations - Digital Conversion Modules, continued



There are several key application considerations and system specifications (bottom of drawing) when using these components (conversion module, cable and output module). Read and understand these considerations before installation. In addition, refer to the current draw requirements of the existing loads for this configuration to ensure they are within the current ratings of the 1756 output module.

Conversion: 1771-OW to 1756-OX8I  
with 1492-CM1771-LD012  
1492-CM1771-LD012

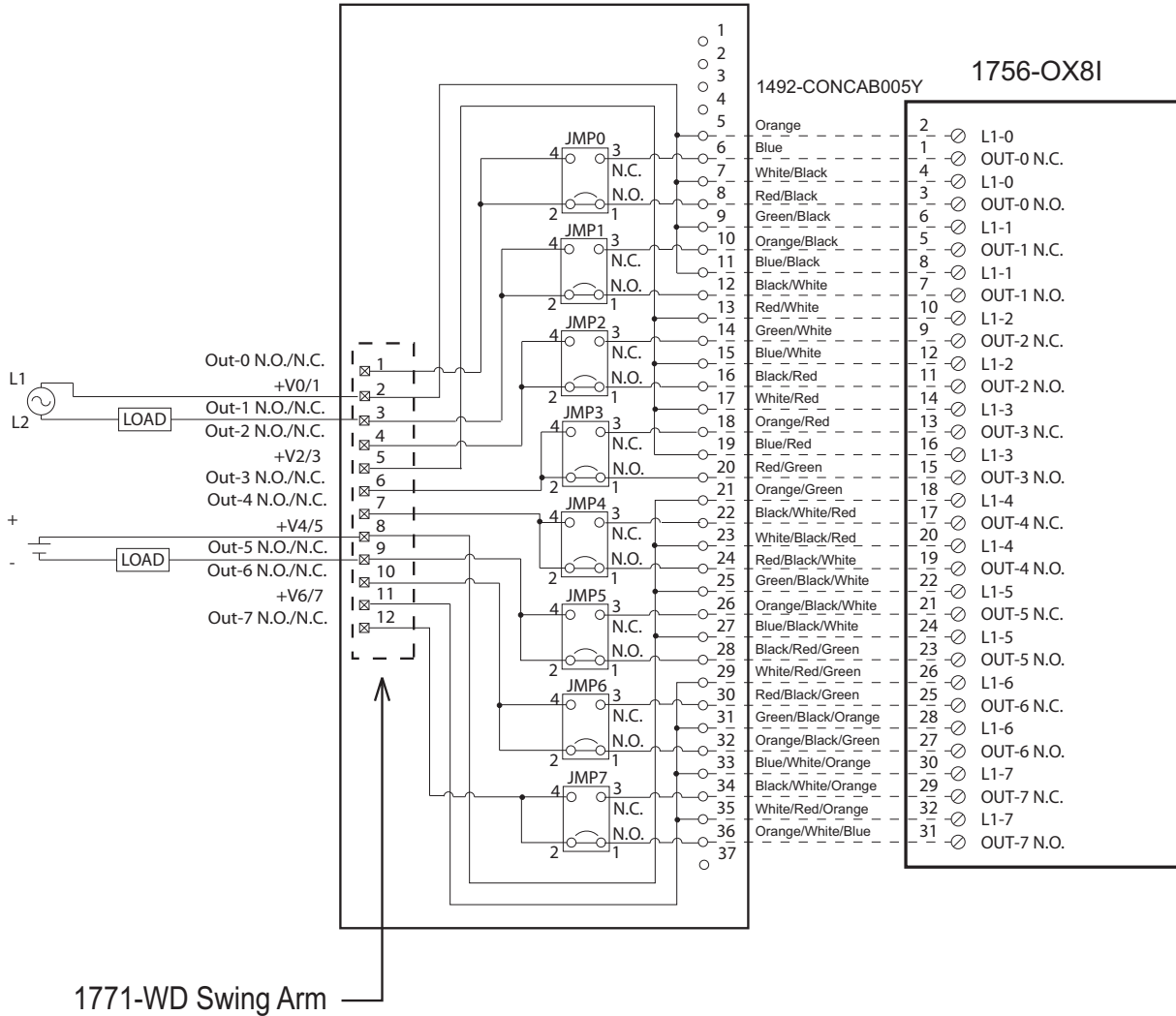

CONVERSION MODULE INSTALLATION AND APPLICATION CONSIDERATIONS

- ① The 1771-OW module output resistive current limits versus 1756-OX8I limits are as follows:  
(NOTE: for switching and inductive current ratings, refer to the modules Installation Instructions)

	1771-OW	1756-OX8I w/ 1492-CONCAB005Y
a) Current/Point	0.2A @ 138V AC	2A @ 240V AC
	1A @ 30V DC	2A @ 30V DC
	0.25A @ 125V DC	0.25A @ 125V DC

- ② The 1492-CONCAB005Y is limited to 3A per pin.
- ③ The 1771-OW module had a jumper selection of N.O. and N.C. outputs. The 1756-OX8I has both N.O. and N.C. relay outputs, but selection is by wiring termination on the 1756 swing arm. The 1492-CM1771-LD012 conversion module replaces the functionality of the 1771-OW jumpers with eight jumpers (JMP0 through JMP7). In the default position, the output will be N.O.. If a N.C. output is required, change the jumper from pins 1-2 to pins 3-4.
- ④ Refer to your 1771-OW and 1756-OX8I Installation Manual wiring schematics and diagrams for more details. Ensure 1756 output module ratings are not exceeded.

41170-941 (0)

# Bulletin 1771 to 1756 I/O Field Wiring Conversion System

## Conversion Module Installation and Application Considerations - Digital Conversion Modules, continued



### WARNING

There are several key application considerations and system specifications (bottom of drawing) when using these components (conversion module, cable and output module). Read and understand these considerations before installation. In addition, refer to the current draw requirements of the existing loads for this configuration to ensure they are within the current ratings of the 1756 output module.

### Conversion: 1771-OAN to 1756-OA16 Qty. 2 with 1492-CM1771-LD013

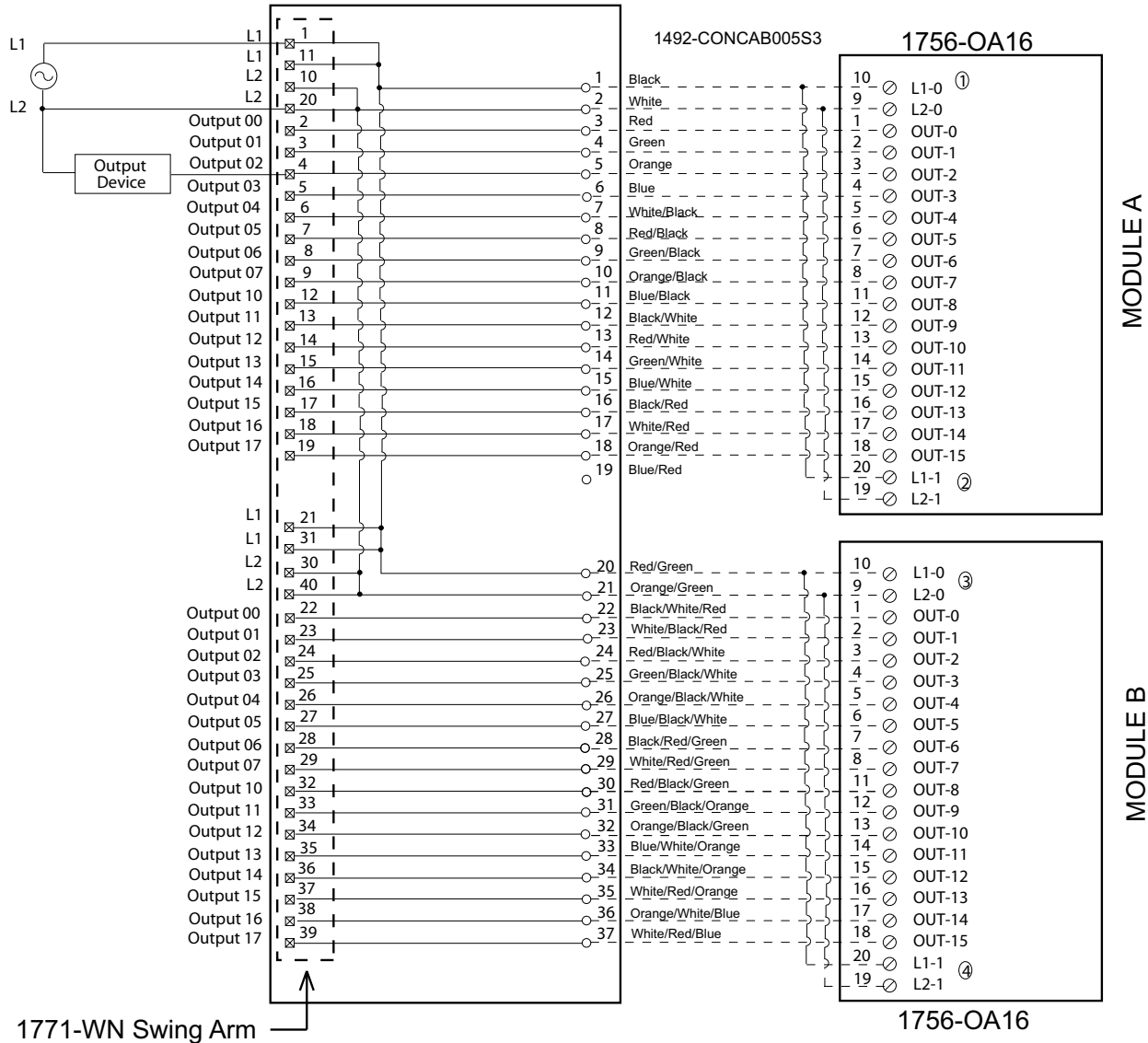

### CONVERSION MODULE INSTALLATION AND APPLICATION CONSIDERATIONS

1) The 1771-OAN module output current limits versus 1756-OA16 limits are as follows:

	1771-OAN	1756-OA16 w/ 1492-CONCAB005S3
a) Current/Point	1A	0.5A
b) Current/Module	8A (32 pts)	2A (16 pts)
c) Surge Current/Point	10A for 25ms	5A for 43ms

- 2) The 1771-OAN has 4 groups (allowing 4 separate power supplies). This module/cable combination ties all 4 groups from the 1771-OAN together. Field wiring modification must be made to accommodate this if multiple supplies were used. If more than 1 supply was used, all but 1 of the power supplies must be removed.
- 3) The 1492-CONCAB005S3 is limited to 3A per pin.
- 4) The 1771-OAN did not allow connections for L2, however the 1756-OA16 requires an L2 connection for proper operation. The 1771-OAN did not use terminals 10, 20, 30, 40. These terminals have been reassigned for an L2 connection in this application. The installer must rewire L2 to one of these terminals.
- 5) Refer to your 1771-OAN and 1756-OA16 Installation Manual wiring schematics and diagrams for more details. Ensure 1756 output module ratings are not exceeded.
- 6) This configuration uses two (2) 1756-OA16 output modules to replace a single 1771-OAN output module. This may require the use of a larger 1756 I/O chassis and conversion mounting assembly. Ensure there is sufficient panel space to allow for this possibility.

41170-942 (1)

# Bulletin 1771 to 1756 I/O Field Wiring Conversion System

## Conversion Module Installation and Application Considerations - Digital Conversion Modules, continued



There are several key application considerations and system specifications (bottom of drawing) when using these components (conversion module, cable and output module). Read and understand these considerations before installation. In addition, refer to the current draw requirements of the existing loads for this configuration to ensure they are within the current ratings of the 1756 output module.

### Conversion: 1771-OA to 1756 -OA8E with 1492-CM1771-LD014

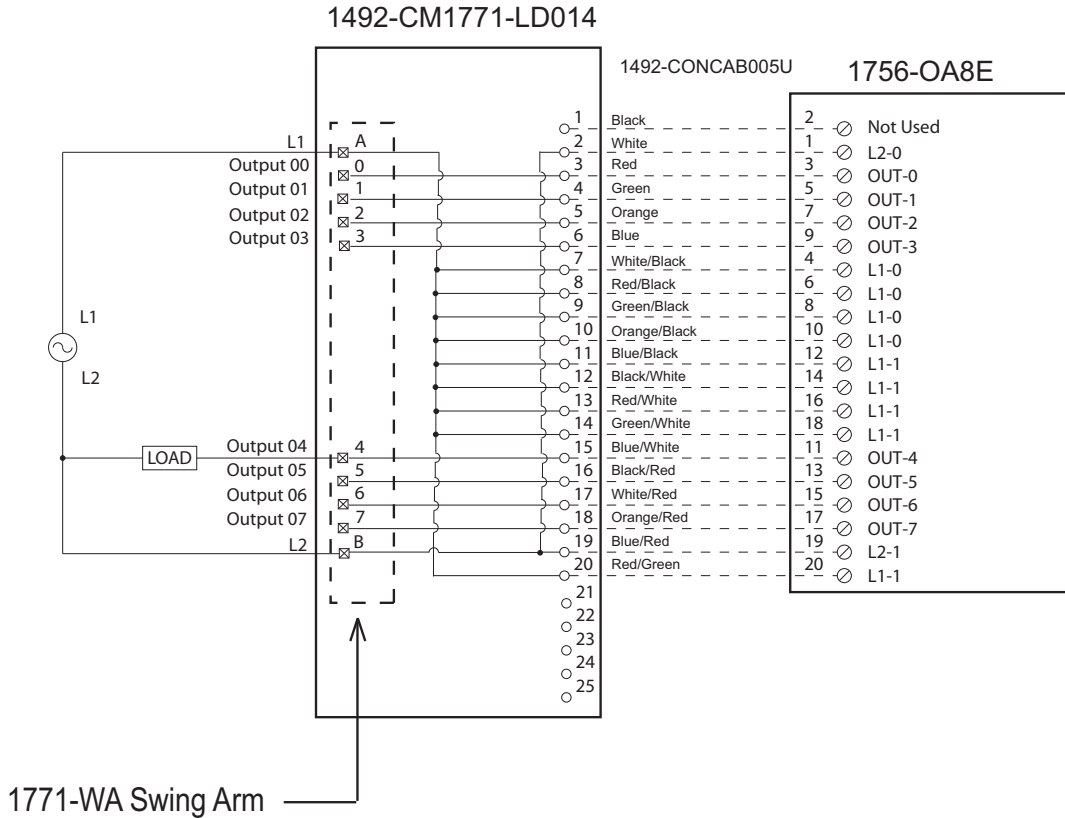

### CONVERSION MODULE INSTALLATION AND APPLICATION CONSIDERATIONS

- ① The 1771-OA module output current limits versus 1756-OA8E limits are as follows:
 

	1771-OA	1756-OA8E w/ 1492-CONCAB005U
a) Current/Point	1.5A	2A
b) Current/Module	6A	4A @ 60°C
c) Surge Current/Point	4A for 8.3ms	20A for 43 ms
- ② The 1771-OA has eight (8) 2A, 250V fuses - 1 per output. The 1756-OA8E is electronically fused per point. Refer to the 1756-OA8E Installation Manual for details on electronic fusing.
- ③ The 1492-CONCAB005U is limited to 3A per pin.
- ④ Refer to your 1771-OA and 1756-OA8E Installation Manual wiring schematics and diagrams for more details. Ensure 1756 output module ratings are not exceeded.

41170-943 (0)

# Bulletin 1771 to 1756 I/O Field Wiring Conversion System

## Conversion Module Installation and Application Considerations - Analog Conversion Modules

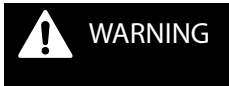

**WARNING**

There are several key application considerations and system specifications (bottom of drawing) when using these components (conversion module, cable and input module). Read and understand these considerations before installation.

### Conversion: 1771-IFE to 1756-IF16 (Single-ended Current) with 1492-CM1771-LA001

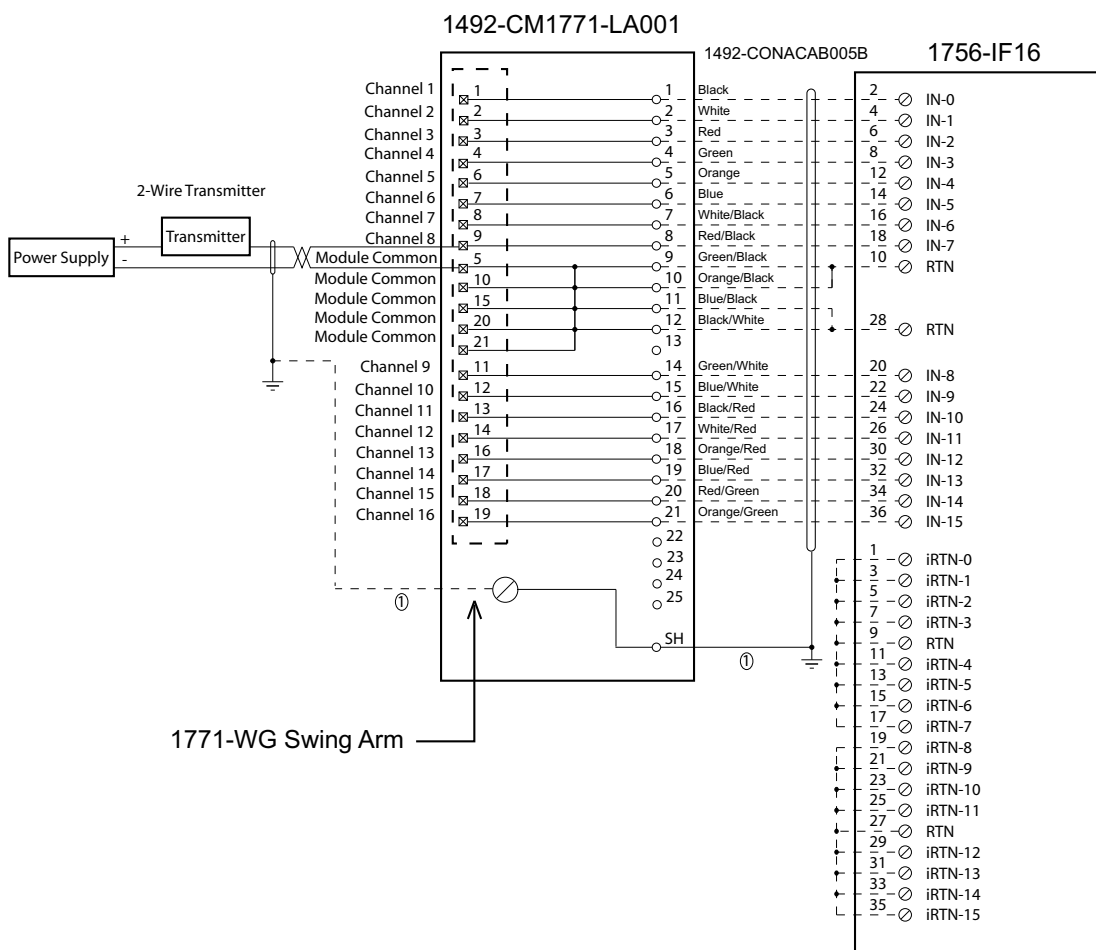

### CONVERSION MODULE INSTALLATION AND APPLICATION CONSIDERATIONS

- ① SHIELD GROUNDING: In some installations, the field wiring shield was grounded on the 1771 chassis. If this was the case, the installer must remove these shield connections from the 1771 chassis and they can be connected to the grounding stud on the 1492-CM1771-LA001 module. The pre-wired cable used between the 1492-CM1771-LA001 module and the 1756-IF16 [1492-CONACAB005B] provides a shield ground lug to ground the shield at the 1756 ControlLogix chassis, this must be connected. Do NOT connect this ground lug to the conversion module grounding stud.
- ② This design assumes that all inputs on the 1771-IFE were connected to current transmitters. If there was a mix of current and voltage transmitters, then modification of the pre-wired cable [1492-CONACAB005B] will need to occur at the 1756-IF16 terminal block. Refer to the 1756-IF16 Installation Manual for modification details.
- ③ The 1771-IFE analog input ranges were configured via software, as is the input range for the 1756-IF16. Please ensure the correct input range is configured in the 1756-IF16.
- ④ Refer to your 1771-IFE and 1756-IF16 Installation and User Manuals for additional information concerning comparisons of module wiring, features and configuration details.

41170-944 (1)



**WARNING**

There are several key application considerations and system specifications (bottom of drawing) when using these components (conversion module, cable and input module). Read and understand these considerations before installation.

**Conversion: 1771-IFE to 1756-IF16 (Single-ended Voltage)  
with 1492-CM1771-LA001**

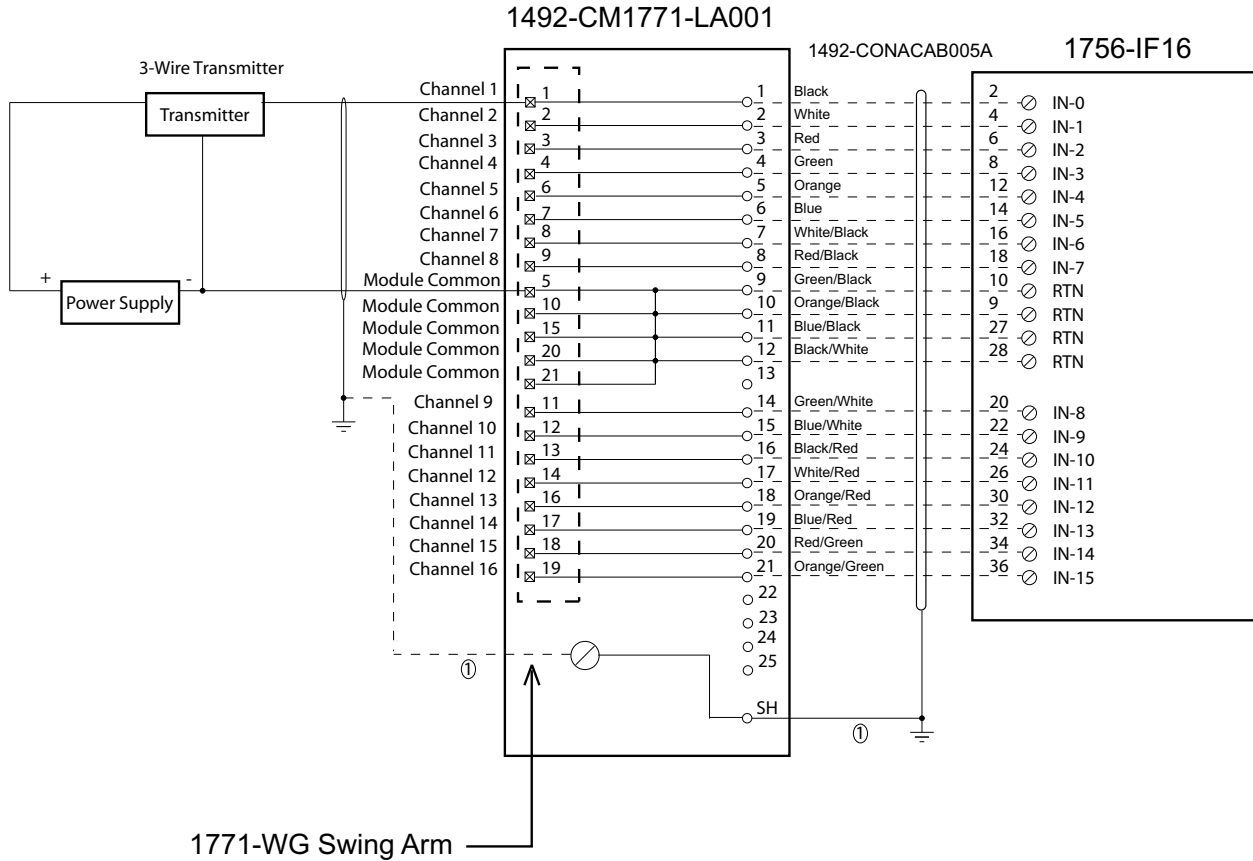

**CONVERSION MODULE INSTALLATION AND APPLICATION CONSIDERATIONS**

- ① SHIELD GROUNDING: In some installations, the field wiring shield was grounded on the 1771 chassis. If this was the case, the installer must remove these shield connections from the 1771 chassis and they can be connected to the grounding stud on the 1492-CM1771-LA001 module. The pre-wired cable used between the 1492-CM1771-LA001 module and the 1756-IF16 [1492-CONACAB005A] provides a shield ground lug to ground the shield at the 1756 ControlLogix chassis, this must be connected. Do NOT connect this ground lug to the conversion module grounding stud.
- ② This design assumes that all inputs on the 1771-IFE were connected to voltage transmitters. If there was a mix of current and voltage transmitters, then modification of the pre-wired cable [1492-CONACAB005A] will need to occur at the 1756-IF16 terminal block. Refer to the 1756-IF16 Installation Manual for modification details.
- ③ The 1771-IFE analog input ranges were configured via software, as is the input range for the 1756-IF16. Please ensure the correct input range is configured in the 1756-IF16.
- ④ Refer to your 1771-IFE and 1756-IF16 Installation and User Manuals for additional information concerning comparisons of module wiring, features and configuration details.

41170-945 (1)



# Bulletin 1771 to 1756 I/O Field Wiring Conversion System

## Conversion Module Installation and Application Considerations - Analog Conversion Modules, continued



**WARNING**

There are several key application considerations and system specifications (bottom of drawing) when using these components (conversion module, cable and input module). Read and understand these considerations before installation.

### Conversion: 1771-IFE to 1756-IF16 (Differential Current) with 1492-CM1771-LA002

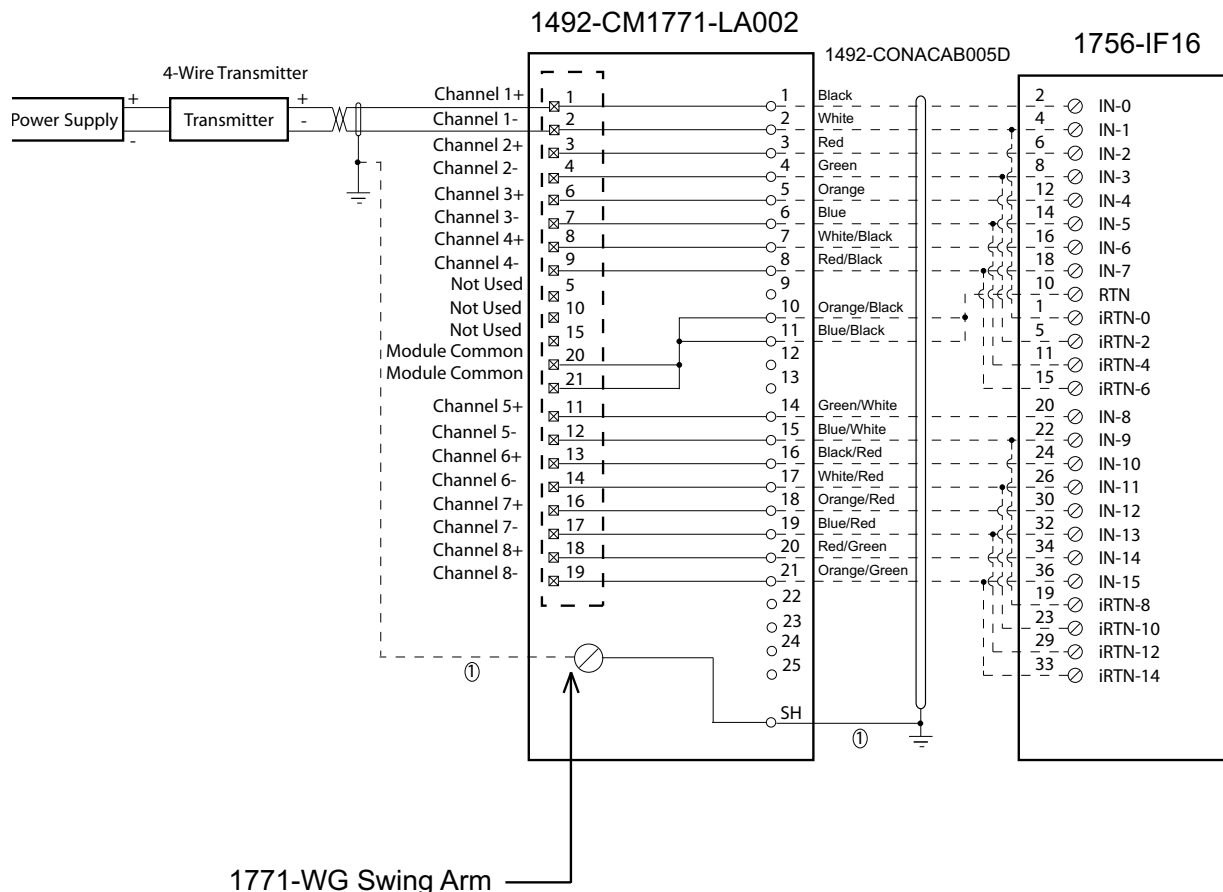

### CONVERSION MODULE INSTALLATION AND APPLICATION CONSIDERATIONS

- ① **SHIELD GROUNDING:** In some installations, the field wiring shield was grounded on the 1771 chassis. If this was the case, the installer must remove these shield connections from the 1771 chassis and they can be connected to the grounding stud on the 1492-CM1771-LA002 module. The pre-wired cable used between the 1492-CM1771-LA002 module and the 1756-IF16 [1492-CONACAB005D] provides a shield ground lug to ground the shield at the 1756 ControlLogix chassis, this must be connected. Do NOT connect this ground lug to the conversion module grounding stud.
- ② This design assumes that all inputs on the 1771-IFE were connected to current transmitters. If there was a mix of current and voltage transmitters, then modification of the pre-wired cable [1492-CONACAB005D] will need to occur at the 1756-IF16 terminal block. Refer to the 1756-IF16 Installation Manual for modification details.
- ③ The 1771-IFE analog input ranges were configured via software, as is the input range for the 1756-IF16. Please ensure the correct input range is configured in the 1756-IF16.
- ④ Refer to your 1771-IFE and 1756-IF16 Installation and User Manuals for additional information concerning comparisons of module wiring, features and configuration details.

41170-946 (1)

Conversion Module Installation and Application Considerations - Analog Conversion Modules, continued

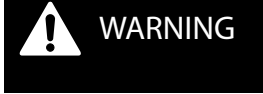

There are several key application considerations and system specifications (bottom of drawing) when using these components (conversion module, cable and input module). Read and understand these considerations before installation.

Conversion: 1771-IFE to 1756-IF16 (Differential Voltage) with 1492-CM1771-LA002

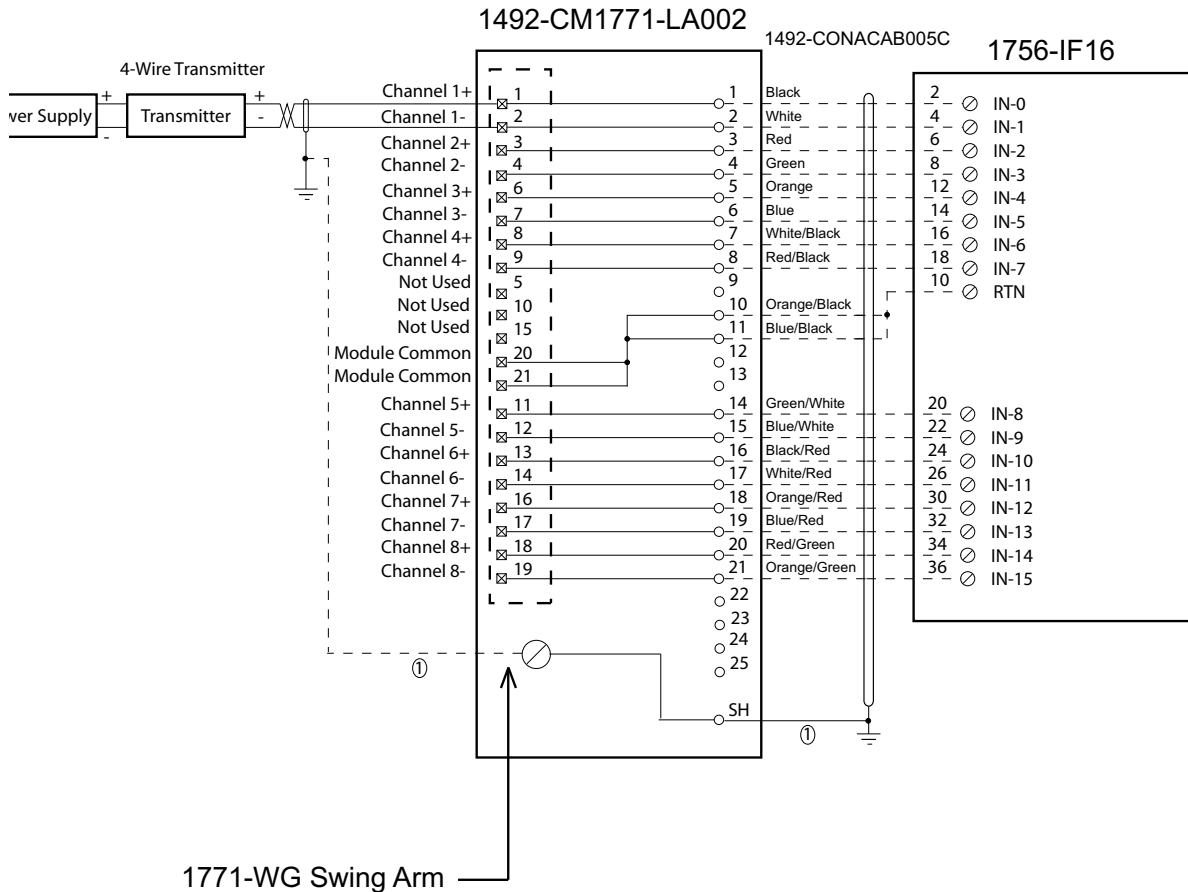

CONVERSION MODULE INSTALLATION AND APPLICATION CONSIDERATIONS

- ① SHIELD GROUNDING: In some installations, the field wiring shield was grounded on the 1771 chassis. If this was the case, the installer must remove these shield connections from the 1771 chassis and they can be connected to the grounding stud on the 1492-CM1771-LA002 module. The pre-wired cable used between the 1492-CM1771-LA002 module and the 1756-IF16 [1492-CONACAB005C] provides a shield ground lug to ground the shield at the 1756 ControlLogix chassis, this must be connected. Do NOT connect this ground lug to the conversion module grounding stud.
- ② This design assumes that all inputs on the 1771-IFE were connected to voltage transmitters. If there was a mix of current and voltage transmitters, then modification of the pre-wired cable [1492-CONACAB005C] will need to occur at the 1756-IF16 terminal block. Refer to the 1756-IF16 Installation Manual for modification details.
- ③ The 1771-IFE analog input ranges were configured via software, as is the input range for the 1756-IF16. Please ensure the correct input range is configured in the 1756-IF16.
- ④ Refer to your 1771-IFE and 1756-IF16 Installation and User Manuals for additional information concerning comparisons of module wiring, features and configuration details.

41170-947 (1)

## Bulletin 1771 to 1756 I/O Field Wiring Conversion System

## Conversion Module Installation and Application Considerations - Analog Conversion Modules, continued

**WARNING**

There are several key application considerations and system specifications (bottom of drawing) when using these components (conversion module, cable and output module). Read and understand these considerations before installation.

### Conversion: 1771-OFE2 to 1756-OF6CI with 1492-CM1771-LA003

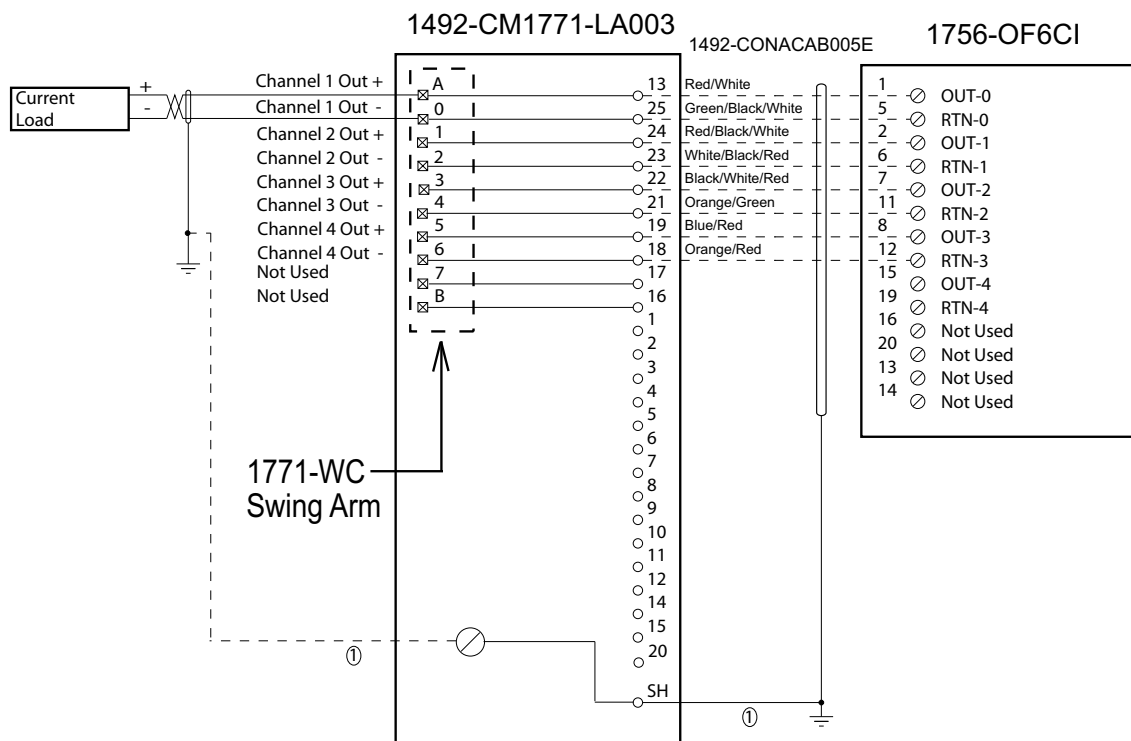

#### CONVERSION MODULE INSTALLATION AND APPLICATION CONSIDERATIONS

- ① **SHIELD GROUNDING:** In some installations, the field wiring shield was grounded on the 1771 chassis. If this was the case, the installer must remove these shield connections from the 1771 chassis and they can be connected to the grounding stud on the 1492-CM1771-LA003 module. The pre-wired cable used between the 1492-CM1771-LA003 module and the 1756-OF6CI [1492-CONACAB005E] provides a shield ground lug to ground the shield at the 1756 ControlLogix chassis, this must be connected. Do NOT connect this ground lug to the conversion module grounding stud.
- ② **IMPORTANT:** The 1771-OFE2 module required the use of an external power supply to drive the analog device. The 1756-OF6CI analog output provides the drive power to the analog device. ENSURE the external power supply is REMOVED from the current loop before applying power to the 1756-OF6CI module or the analog output module may be damaged.
- ③ The 1771-OFE2 analog output ranges were factory set, the output range for the 1756-OF6CI is software configured. Please ensure the correct output range is configured in the 1756-OF6CI.
- ④ The 1756-OF6CI module can drive a load up to 550 ohms with the standard pre-configured cable [1492-CONACAB005E]. If greater than a 550 ohm drive current is required, the pre-wired cable can be modified at the 1756-OF6CI terminal block to drive up to a 1000 ohms. Refer to the 1756-OF6CI Installation Manual for modification details.
- ⑤ Refer to your 1771-OFE2 and 1756-OF6CI Installation and User Manuals for additional information concerning comparisons of module wiring, features and configuration details.

41170-948 (1)



Conversion Module Installation and Application Considerations - Analog Conversion Modules, continued

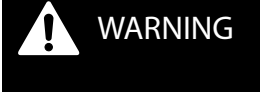

There are several key application considerations and system specifications (bottom of drawing) when using these components (conversion module, cable and output module). Read and understand these considerations before installation.

Conversion: 1771-OFE1 to 1756 -OF6VI  
with 1492-CM1771-LA003

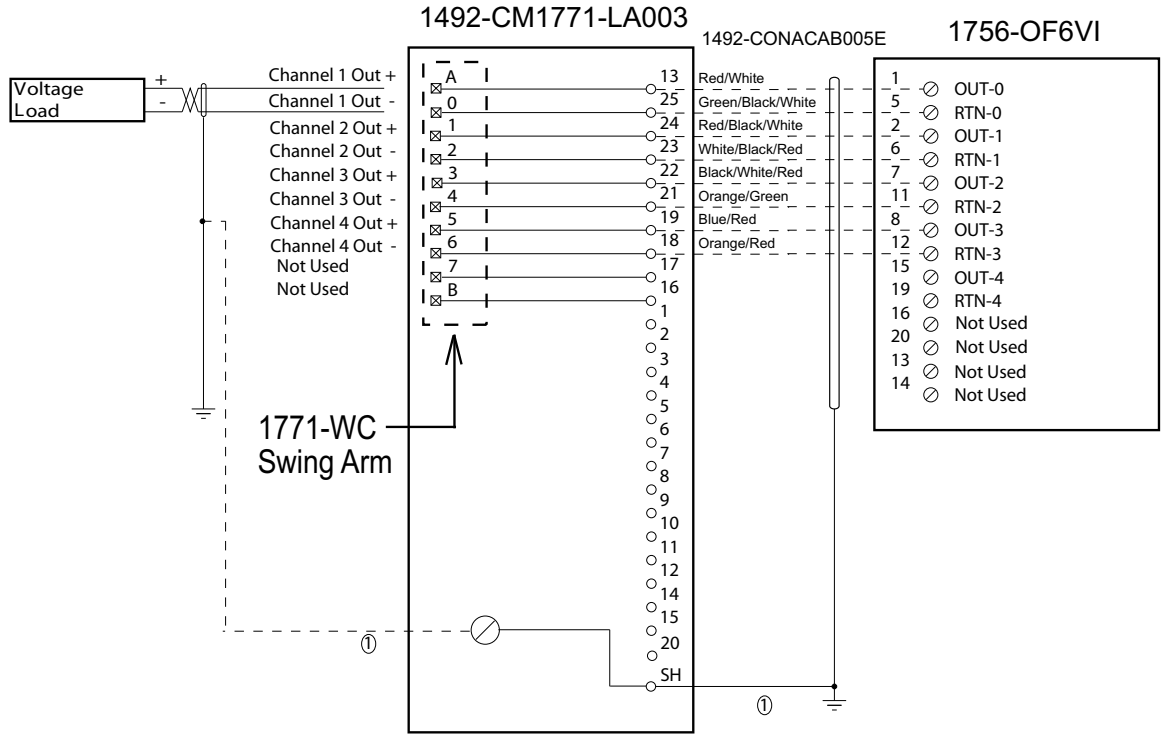

CONVERSION MODULE INSTALLATION AND APPLICATION CONSIDERATIONS

- ① SHIELD GROUNDING: In some installations, the field wiring shield was grounded on the 1771 chassis. If this was the case, the installer must remove these shield connections from the 1771 chassis and they can be connected to the grounding stud on the 1492-CM1771-LA003 module. The pre-wired cable used between the 1492-CM1771-LA003 module and the 1756-OF6VI [1492-CONACAB005E] provides a shield ground lug to ground the shield at the 1756 ControlLogix chassis, this must be connected. Do NOT connect this ground lug to the conversion module grounding stud.
- ② The 1771-OFE1 analog output range was configured by jumpers, the output range for the 1756-OF6VI is software configured. Please ensure the correct output range is configured in the 1756-OF6VI.
- ③ Refer to your 1771-OFE1 and 1756-OF6VI Installation and User Manuals for additional information concerning comparisons of module wiring, features and configuration details.

41170-949 (1)

# Bulletin 1771 to 1756 I/O Field Wiring Conversion System

## Conversion Module Installation and Application Considerations - Analog Conversion Modules, continued



### WARNING

There are several key application considerations and system specifications (bottom of drawing) when using these components (conversion module, cable and input module). Read and understand these considerations before installation.

### Conversion: 1771-IR to 1756-IR6I with 1492-CM1771-LA004

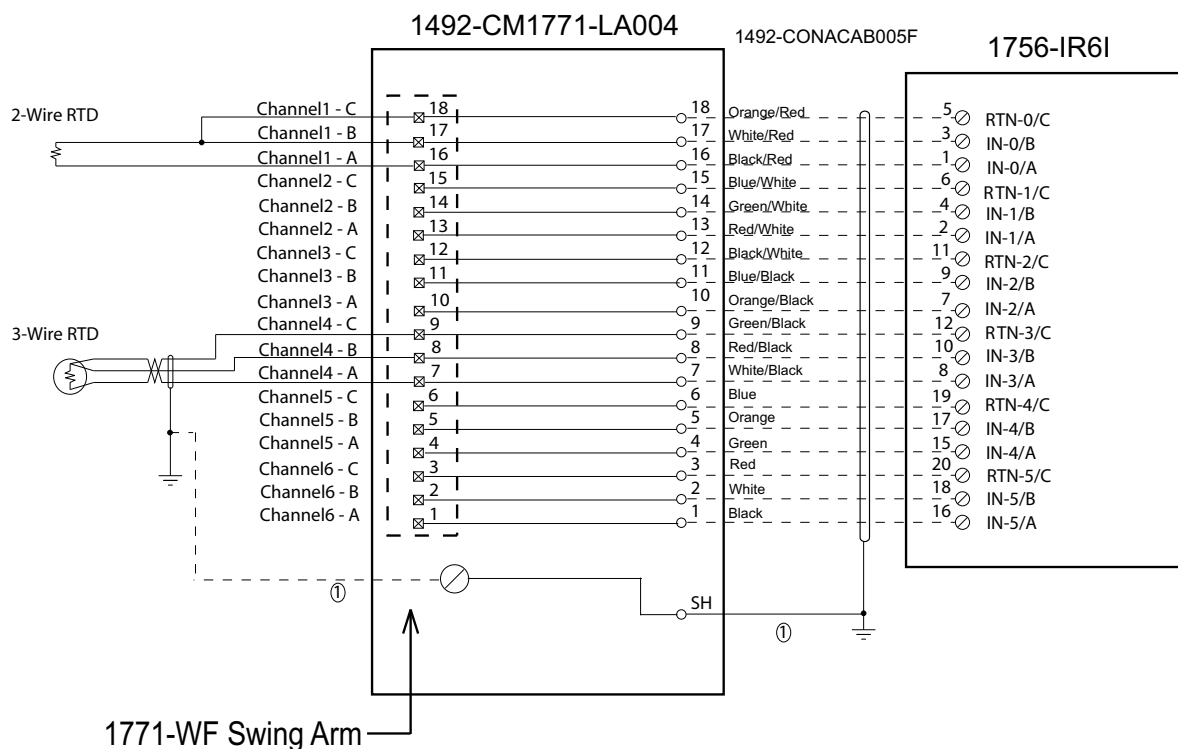

### CONVERSION MODULE INSTALLATION AND APPLICATION CONSIDERATIONS

- ① SHIELD GROUNDING: In some installations, the field wiring shield was grounded on the 1771 chassis. If this was the case, the installer must remove these shield connections from the 1771 chassis and they can be connected to the grounding stud on the 1492-CM1771-LA004 module. The pre-wired cable used between the 1492-CM1771-LA004 module and the 1756-IR6I [1492-CONACAB005F] provides a shield ground lug to ground the shield at the 1756 ControlLogix chassis, this must be connected. Do NOT connect this ground lug to the conversion module grounding stud.
- ② The 1771-IR input configuration was software configured, as is the 1756-IR6I. Please ensure the correct configuration in the 1756-IR6I.
- ③ Refer to your 1771-IR and 1756-IR6I Installation and User Manuals for additional information concerning comparisons of module wiring, features and configuration details.

41170-950 (1)



Allen-Bradley, Rockwell Software, and ControlLogix are trademarks of Rockwell Automation, Inc.

**[www.rockwellautomation.com](http://www.rockwellautomation.com)**

---

**Power, Control and Information Solutions Headquarters**

Americas: Rockwell Automation, 1201 South Second Street, Milwaukee, WI 53204 USA, Tel: (1) 414.382.2000, Fax: (1) 414.382.4444

Europe/Middle East/Africa: Rockwell Automation, Vorstlaan/Boulevard du Souverain 36, 1170 Brussels, Belgium, Tel: (32) 2 663 0600, Fax: (32) 2 663 0640

Asia Pacific: Rockwell Automation, Level 14, Core F, Cyberport 3, 100 Cyberport Road, Hong Kong, Tel: (852) 2887 4788, Fax: (852) 2508 1846