



BACnet® Protocol AYK550 AC Drives

USER'S MANUAL

New Release

Form:100.42-N1 (1204)

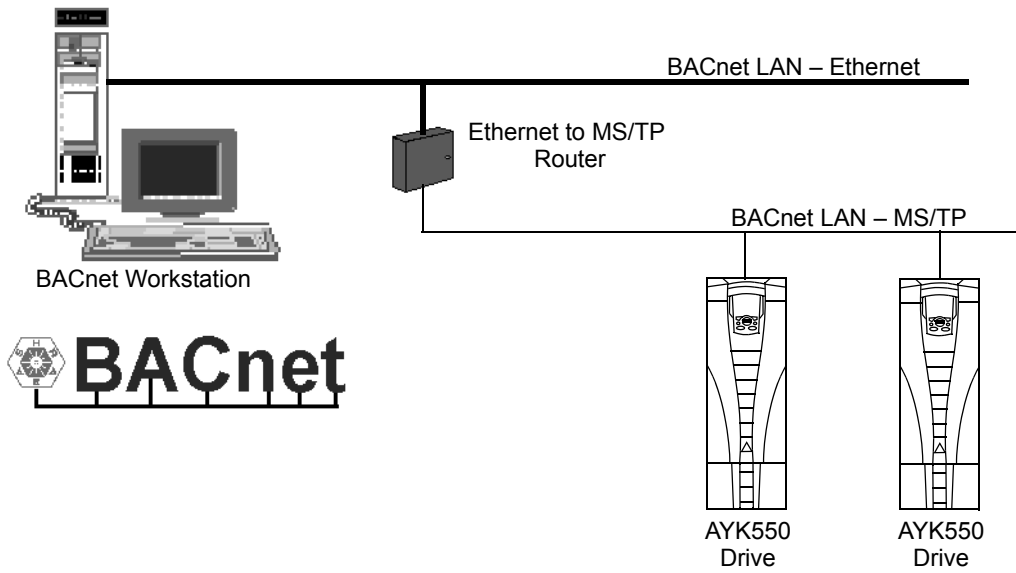

Note:

The AYK550 BACnet User's Manual is to be used with
AYK550 Air Modulator User's Manual 100.42-01 (604)

Safety



WARNING! The AYK550 adjustable speed AC drive should **ONLY** be installed by a qualified electrician.



WARNING! Even when the motor is stopped, dangerous voltage is present at the Power Circuit terminals U1, V1, W1 and U2, V2, W2 and, depending on the frame size, UDC+ and UDC-, or BRK+ and BRK-.



WARNING! Dangerous voltage is present when input power is connected. After disconnecting the supply, wait at least 5 minutes (to let the intermediate circuit capacitors discharge) before removing the cover.



WARNING! Even when power is removed from the input terminals of the AYK550, there may be dangerous voltage (from external sources) on the terminals of the relay outputs R01...R03.



WARNING! When the control terminals of two or more drive units are connected in parallel, the auxiliary voltage for these control connections must be taken from a single source which can either be one of the units or an external supply.



WARNING! The AYK550-01/U1 is not a field repairable unit. Never attempt to repair a malfunctioning unit; contact the factory or your local Authorized Service Center for replacement.



WARNING! The AYK550 will start up automatically after an input voltage interruption if the external run command is on.

Note! For more technical information, contact the factory or your local YORK sales representative.

Use of Warnings and Notes

There are two types of safety instructions throughout this manual:

- Notes draw attention to a particular condition or fact, or give information on a subject.
- Warnings caution you about conditions which can result in serious injury or death and/or damage to the equipment. They also tell you how to avoid the danger. The warning symbols are used as follows:



Dangerous voltage warning warns of high voltage which can cause physical injury and/or damage to the equipment.



General warning warns about conditions, other than those caused by electricity, which can result in physical injury and/or damage to the equipment.

Table of Contents

Safety

Use of Warnings and Notes	3
---------------------------------	---

Table of Contents

Installation

Introduction	7
Overview	7
Control Interface	7
Planning	8
Hardware Installation	8

Start-up

Communications Setup	10
Drive Parameter Group 53	10
Quick-Start Sequence	11
Activate Drive Control Functions	13
Controlling the Drive	13
Start/Stop Direction Control	13
Input Reference Select	13
Miscellaneous Drive Control	13
Relay Output Control	14
Analog Output Control	14
PID Control Setpoint Source	14
Communication Fault	15
Feedback from the Drive	15
Pre-defined Feedback	15
Mailbox Read/Write	15

Diagnostics

Fault Queue for Drive Diagnostics	17
Serial Communication Diagnostics	17
Diagnostic Situations	17

Technical Data

Protocol Implementation Conformance Statement (PICS)	20
PICS Summary	20
Statement	22
Object Definitions	24
Object/Property Support Matrix	24
Binary Input Object Instance Summary	25
Binary Output Object Instance Summary	25
Binary Value Object Instance Summary	26
Analog Input Object Instance Summary	28

Analog Output Object Instance Summary 28
Analog Value Object Instance Summary 29

Index

Installation

Introduction

Overview

The AYK550 can be set up to accept control from an external system using standard serial communication protocols. When using serial communication, the AYK550 can either:

- Receive all of its control information from the fieldbus, or
- Be controlled from some combination of fieldbus control and other available control locations, such as digital or analog inputs, and the control panel.

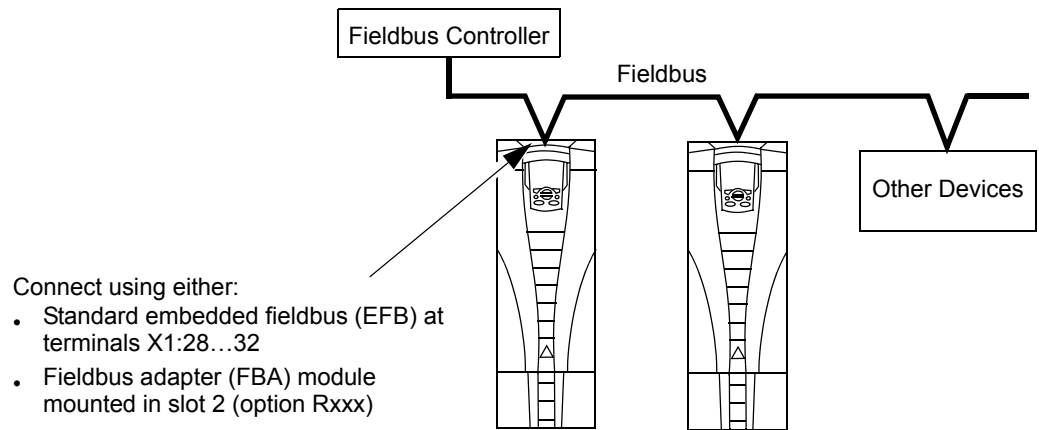

Two basic serial communications configurations are available:

- Embedded fieldbus (EFB) – Using the RS485 interface at terminals X1:28...32 on the control board, a control system can communicate through the drive's standard EFB using standard protocols, one of which is BACnet.
- Fieldbus adapter (FBA) – See the AYK550 User's Manual.

Control Interface

In general, the basic control interface between the fieldbus system and the drive consists of:

Protocol	Control Interface	Reference for more information
BACnet	<ul style="list-style-type: none"> • Device management • Binary output objects • Analog output objects • Binary input objects • Analog input objects 	"Technical Data"

Note! The words “output” and “input” are used as seen from the fieldbus controller point of view. For example an output describes data flow from the fieldbus controller to the drive and appears as an input from the drive point of view.

Planning

Network planning should address the following questions:

- What types and quantities of devices must be connected to the network?
- What control information must be sent down to the drives?
- What feedback information must be sent from the drives to the controlling system?

Hardware Installation



WARNING! Connections should be made only while the drive is disconnected from the power source.

Drive terminals 28...32 are for RS485 communications.

- Use Belden 9842 or equivalent. Belden 9842 is a dual twisted, shielded pair cable with a wave impedance of 120 Ω
- Use one of these twisted shielded pairs for the RS485 link. Use this pair to connect all A (-) terminals together and all B (+) terminals together.
- Use one of the wires in the other pair for the logical ground (terminal 31), leaving one wire unused.
- Do not directly ground the RS485 network at any point. Ground all devices on the network using their corresponding earthing terminals.
- As always, the grounding wires should not form any closed loops, and all the devices should be earthed to a common ground.
- Connect the RS485 link in a daisy-chained bus, without dropout lines.
- To reduce noise on the network, terminate the RS485 network using 120 Ω resistors at both ends of the network. Use the DIP switch to connect or disconnect the termination resistors. See following diagram and table.

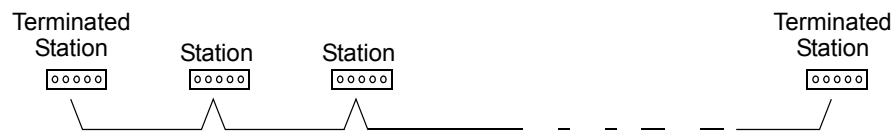

X1	Identification	Hardware Description	
28	Screen	RS485 Multidrop application	
29	B (Positive +)		28 SCR
30	A (Negative -)		29 B
31	AGND		30 A
32	Screen		31 AGND
		<p data-bbox="1214 264 1398 296">RS485 interface</p> <div data-bbox="1154 306 1458 495"> </div>	

- Connect the shield at each end of the cable to a drive. On one end, connect the shield to terminal 28, and on the other end connect to terminal 32. Do not connect the incoming and outgoing cable shields to the same terminals, as that would make the shielding continuous.
- For configuration information see the following:
 - "Communications Setup" on page 10.
 - "Activate Drive Control Functions" on page 13.
 - "Technical Data" on page 20.

Start-up

Communications Setup

Drive Parameter Group 53

Drive parameter Group 53 defines features unique to BACnet, as described below:

Parameter		Default Value	BACnet-specific Description
5301	EFB PROTOCOL ID	x5xx	This parameter indicates the active protocol and its revision. It should read x50xx if BACnet is properly loaded. If this is not the case, confirm that drive parameter 9802 = BACNET (5).
5302	EFB STATION ID	1	This parameter sets the drive's BACnet MS/TP MAC ID. A value of 0 places the protocol channel in reset.
5303	EFB BAUD RATE	9600	This parameter sets the BACnet MS/TP baud rate.
5304	EFB PARITY	0	This parameter sets the BACnet MS/TP character format as follows: 0 = 8N1 1 = 8N2 2 = 8E1 3 = 8O1.
5305	EFB CTRL PROFILE	-	This parameter indicates the active control profile. This parameter has no affect on BACnet behavior.
5306	EFB OK MESSAGES	-	This parameter indicates the number of valid messages received at this node. During normal operation, this value should be continually increasing.
5307	EFB CRC ERRORS	-	This parameter indicates the number of CRC errors detected, in either the header or data CRCs.
5308	EFB UART ERRORS	-	This parameter indicates the number of UART-related errors (framing, parity) detected.
5309	EFB STATUS	-	This parameter indicates the internal status of the BACnet channel as follows: <ul style="list-style-type: none"> • IDLE – BACnet channel is configured but not receiving messages. • TIMEOUT – Time between valid messages has exceeded the interval set by parameter 3019. • OFFLINE – BACnet channel is receiving messages NOT addressed to this drive. • ONLINE – BACnet channel is receiving messages addressed to this drive. • RESET – BACnet channel is in reset. • LISTEN ONLY – BACnet channel is in listen-only mode.
5310	EFB PAR 10	5	This parameter sets the BACnet MS/TP response turn-around time, in milliseconds.
5311	EFB PAR 11	0	This parameter sets the BACnet Device Object Instance. If 0, the MS/TP MAC ID (5302 above) "doubles" as the Device Object Instance.

Parameter		Default Value	BACnet-specific Description
5312	EFB PAR 12	1	This parameter sets the BACnet Device Object Max Info Frames property.
5313	EFB PAR 13	127	This parameter sets the BACnet Device Object Max Master property.
5314	EFB PAR 14	0	This parameter enables autobaud detection. 0 = DISABLE 1 = ENABLE
5315	EFB PAR 15		When autobaud detection is enabled, this parameter displays the detected baud rate.
5316 ... 5320	EFB PAR 16...20		N/A - Not supported with BACnet protocol.

Changes made to drive parameter Group 53, EFB Protocol, do not take affect until you perform one of the following:

- Cycle the drive power OFF and ON, or
- Set parameter 5302 to 0, and then back to a unique MAC ID, or
- Use the ReinitializeDevice service.

Quick-Start Sequence

The following steps summarize the process for enabling and configuring BACnet on the AYK550:

1. Enable BACnet protocol: Set drive parameter 9802, COMM PROTOCOL SEL = BACNET (5).

Note! If you cannot see the desired selection on the panel, your drive does not have that protocol software in the application memory.

2. Place the BACnet channel in "reset": Set drive parameter 5302, EFB STATION ID = 0.
 - This setting holds the BACnet communication channel in reset while remaining settings are completed.
3. Define the MS/TP baud rate.
 - If MS/TP baud rate is known: Set drive parameter 5303, EFB BAUD RATE = appropriate value.
 - If MS/TP baud rate is unknown: Set drive parameter 5314, EFB PAR 14 = 1 to enable autobaud detection.
4. Define the Device Object instance.
 - To define a specific device object instance value, set drive parameter 5311, EFB PAR 11, to the specific value (object instance values must be unique).

- To use the drive's MS/TP MAC ID as the device object instance value, set drive parameter 5311, EFB PAR 11 = 0.
5. Define a unique MS/TP MAC ID. Set drive parameter 5302, EFB STATION ID = appropriate value.
 - Once this parameter is set to a non-zero value, current BACnet settings are "latched" and used for communication until the channel is reset.
 - In order to participate in MS/TP token passing, the MAC ID used must be within the limits defined by other masters' "Max Master" property.
 6. Confirm proper BACnet communication.
 - When BACnet communication is operating properly, drive parameter 5306, EFB OK MESSAGES, should be continually increasing.
 - Drive parameter 5306, UART ERRORS, should be stable. (With autobaud detection, this parameter may increase until the proper baud rate is detected.)
 - With autobaud detection, once the proper baud rate is detected, drive parameter 5315 EFB PAR 15, shows the active baud rate.

Activate Drive Control Functions

Controlling the Drive

Fieldbus control of various drive functions requires configuration to:

- Tell the drive to accept fieldbus control of the function.
- Define as a fieldbus input, any drive data required for control.
- Define as a fieldbus output, any control data required by the drive.

The following sections describe the configuration required for each control function.

Start/Stop Direction Control

Using the fieldbus for start/stop/direction control of the drive requires:

- Drive parameter values set as defined below.
- Fieldbus controller supplied command(s) in the appropriate location.

Drive Parameter		Value	Description	BACnet Access Point
1001	EXT1 COMMANDS	COMM (10)	Start/Stop by fieldbus with Ext1 selected.	BV10
1002	EXT2 COMMANDS	COMM (10)	Start/Stop by fieldbus with Ext2 selected.	BV10
1003	DIRECTION	REQUEST (3)	Direction by fieldbus.	BV11

Input Reference Select

Using the fieldbus to provide input references to the drive requires:

- Drive parameter values set as defined below.
- Fieldbus controller supplied reference word(s) in the appropriate location.

Drive Parameter		Value	Description	BACnet Access Point
1102	EXT1/EXT2 SEL	COMM (8)	Reference set selection by fieldbus.	BV13
1103	REF1 SEL	COMM (8)	Input reference 1 by fieldbus.	AV16
1106	REF2 SEL	COMM (8)	Input reference 2 by fieldbus.	AV17

Miscellaneous Drive Control

Using the fieldbus for miscellaneous drive control requires:

- Drive parameter values set as defined below.
- Fieldbus controller supplied command(s) in the appropriate location.

Drive Parameter		Value	Description	BACnet Access Point
1601	RUN ENABLE	COMM (7)	Run enable by fieldbus.	BV12
1604	FAULT RESET SEL	COMM (8)	Fault reset by fieldbus.	BV14

Relay Output Control

Using the fieldbus for relay output control requires:

- Drive parameter values set as defined below.
- Fieldbus controller supplied, binary coded, relay command(s) in the appropriate location.

Drive Parameter		Value	Description	BACnet Access Point
1401	RELAY OUTPUT 1	COMM (35)	Relay Output 1 controlled by fieldbus.	BO0
1402	RELAY OUTPUT 2	COMM (35)	Relay Output 2 controlled by fieldbus.	BO1
1403	RELAY OUTPUT 3	COMM (35)	Relay Output 3 controlled by fieldbus.	BO2
1410 ¹	RELAY OUTPUT 4	COMM (35)	Relay Output 4 controlled by fieldbus.	BO3
1411 ¹	RELAY OUTPUT 5	COMM (35)	Relay Output 5 controlled by fieldbus.	BO4
1412 ¹	RELAY OUTPUT 6	COMM (35)	Relay Output 6 controlled by fieldbus.	BO5

1. More than 3 relays requires the addition of a relay extension module.

Note! Relay status feedback occurs without configuration as defined below.

Drive Parameter		Value	BACnet Access Point
0122	RO 1-3 STATUS	Relay 1...3 status.	BO0, BO1, BO2
0123	RO 4-6 STATUS	Relay 4...6 status.	BO3, BO4, BO5

Analog Output Control

Using the fieldbus for analog output control (e.g. PID setpoint) requires:

- Drive parameter values set as defined below.
- Fieldbus controller supplied analog value(s) in the appropriate location.

Drive Parameter		Value	Description	BACnet Access Point
1501	AO1 CONTENT SEL	135 (COMM VALUE 1)	Analog Output 1 controlled by writing to parameter 0135.	AO0
1507	AO2 CONTENT SEL	136 (COMM VALUE 2)	Analog Output 2 controlled by writing to parameter 0136.	AO1

PID Control Setpoint Source

Using the fieldbus for the PID control setpoint requires:

- Drive parameter values set as defined below.

- Fieldbus controller supplied setpoint value in the appropriate location. (As defined in "Analog Output Control" above.)

Drive Parameter		Value	Description	BACnet Access Point
4010	SETPOINT SEL	8 (COMM VALUE 1) 9 (COMM + AI1) 10 (COMM*AI1)	Setpoint is 0135 value (plus or times AI1)	See "Analog Output Control".

Communication Fault

When using fieldbus control, specify the drive's action if serial communication is lost.

Drive Parameter		Value	Description
3018	COMM FAULT FUNC	0 (NOT SEL) 1 (FAULT) 2 (CONST SP7) 3 (LAST SPEED)	Set for appropriate drive response.
3019	COMM FAULT TIME		Set time delay before acting on a communication loss.

Feedback from the Drive

Pre-defined Feedback

Inputs to the controller (drive outputs) have pre-defined meanings established by the protocol. This feedback does not require drive configuration. The following table lists a sample of feedback data. For a complete listing, see input word/point/object listings in the "Technical Data" section.

Drive Parameter		BACnet Access Point
0102	SPEED	AV0
0103	FREQ OUTPUT	AV1
0104	CURRENT	AV4
0105	TORQUE	AV5
0106	POWER	AV6
0107	DC BUS VOLT	AV2
0109	OUTPUT VOLTAGE	AV3
0115	KWH COUNTER	AV8
0118	DI1-3 STATUS	BI6, BI7, BI8
0122	RO1-3 STATUS	BI0, BI1, BI2

Mailbox Read/Write

The AYK550 provides a "Mailbox" function to access parameters that have not been pre-defined by the protocol. Using mailbox, any drive parameter can be identified and read. Mailbox can also be used to adjust parameter settings by writing a value to any parameter identified. The following table describes the use of this function.

Drive Parameter		BACnet Access Point
Mailbox Parameter	Enter the number of the drive parameter to access.	AV 25

Drive Parameter		BACnet Access Point
Mailbox Data	Contains the parameter value after a read, or enter the desired parameter value for a write.	AV 26
Mailbox Read	A binary value triggers a read – the value of the “Mailbox Parameter” appears in “Mailbox data”.	BV 15
Mailbox Write	A binary value triggers a write – the drive value for the “Mailbox Parameter” changes to the value in “Mailbox data”.	BV 16

Note! You must read and write mailbox values using the drive's internal scaling. For example, the parameter 2202, ACCEL TIME1, has a resolution of 0.1 sec., which means that, in the drive (and in the mailbox), the value 1 = 0.1 seconds. So, a mailbox value of 10 translates to 1.0 second, a mailbox value of 300 translates to 30.0 seconds, etc. Refer to the parameter listing in the AYK550 User's Manual for each parameter's resolution and units of measure.

Diagnostics

Fault Queue for Drive Diagnostics

For general AYK550 diagnostics information, see “Diagnostics” in the AYK550 User’s Manual. The three most recent AYK550 faults are reported to the fieldbus as defined below.

	Drive Parameter	BACnet Access Point
0401	Last Fault	AV 18
0412	Previous Fault 1	AV 19
0413	Previous Fault 2	AV 20

Serial Communication Diagnostics

Network problems can be caused by multiple sources. Some of these sources are:

- Loose connections
- Incorrect wiring (including swapped wires)
- Incorrect baud rate
- Bad grounding
- Duplicate station numbers
- Incorrect setup of drives or other devices on the network

The major diagnostic features for fault tracing on an EFB network include Group 53 EFB Protocol parameters 5306...5309. The “Parameter Descriptions” section, in the AYK550 User’s Manual, describes these parameters in detail.

Diagnostic Situations

The sub-sections below describe various diagnostic situations – the problem symptoms and corrective actions.

Normal Operation

During normal network operation, 5306...5309 parameter values act as follows at each drive:

- 5306 EFB OK MESSAGES advances (advances for each message properly received and addressed to this drive).
- 5307 EFB CRC ERRORS does not advance at all (advances when an invalid message CRC is received).
- 5308 EFB UART ERRORS does not advance at all (advances when character format errors are detected, such as parity or framing errors).
- 5309 EFB status value varies depending on network traffic.

Loss of Communication

The AYK550 behavior, if communication is lost, was configured earlier in "Communication Fault" on page 15. The parameters are 3018 COMM FAULT FUNC and 3019 COMM FAULT TIME. The "Parameter Descriptions" section in the AYK550 User's Manual describes these parameters in detail.

No Master Station on Line

If no master station is on line: Neither 5306, EFB OK MESSAGES, nor the errors (5307 EFB CRC ERRORS and 5308 EFB UART ERRORS) increase on any of the stations.

To correct:

- Check that a network master is connected and properly programmed on the network.
- Verify that the cable is connected, and is not cut or short circuited.

Duplicate Stations

If two or more stations have duplicate numbers:

- Two or more drives cannot be addressed.
- Every time there is a read or write to one particular station, the value for 5307 EFB CRC ERRORS or 5308 EFB UART ERRORS advances.

To correct: Verify the station numbers of all stations. Change conflicting station numbers.

Swapped Wires

If the communication wires are swapped (terminal A on one drive is connected to terminal B on another):

- The value of 5306 EFB OK MESSAGES does not advance.
- The values of 5307 EFB CRC ERRORS and 5308 EFB UART ERRORS are advancing.

To correct: Check that the RS-485 lines are not swapped.

Fault 28 – Serial 1 Err

If the drive's control panel shows fault code 28 "SERIAL 1 ERR", check for either of the following:

- The master system is down. To correct, resolve problem with master system.
- The communication connection is bad. To correct, check communication connection at the drive.
- The time-out selection for the drive is too short for the given installation. The master is not polling the drive within the specified time-out delay. To correct, increase the time set by parameter 3019 COMM FAULT TIME.

Faults 31...33 – EFB1...EFB3

The three EFB fault codes (fault codes 31...33) listed for the drive in the "Diagnostics" section of the AYK550 User's Manual are not used.

Incorrect Baud Rate

If the baud rate setting does not match the network's rate, the value of 5308, EFB UART ERRORS, increases and the value of 5306, EFB OK MESSAGES, remains fixed.

If uncertain of the segment baud rate, use the autobaud detection mode, as described in "Communications Setup".

Intermittent Off-line Occurrences

The problems described above are the most common problems encountered with AYK550 serial communication. Intermittent problems might also be caused by:

- Marginally loose connections.
- Wear on wires caused by equipment vibrations.
- Insufficient grounding and shielding on both the devices and on the communication cables.
- Missing network terminations (stations at both ends of a network require termination resistors).

Technical Data

Protocol Implementation Conformance Statement (PICS)

PICS Summary

BACnet Standard Device Profile

This version of AYK550 BACnet fully conforms to the 'Application-Specific Controller' standard device profile (B-ASC).

Services Supported

The following services are supported by the AYK550:

- I-Am (Response to Who-Is, also broadcast on power-up & other reset)
- I-Have (Response to Who-Has)
- ReadProperty
- WriteProperty
- DeviceCommunicationControl
- ReinitializeDevice

Data Link Layer

The AYK550 implements MS/TP (Master) Data Link Layer. All standard MS/TP baud rates are supported (9600, 19200, 38400 & 76800).

MAC ID / Device Object Instance

The AYK550 supports separate MAC ID and Device Object Instance parameters:

- Set the MAC ID using drive parameter 5302. Default: 5302 = 1.
- Set the Device Object Instance using drive parameter 5311. Default: 5311 = 0, which causes the MAC ID to “double” as the Device Object Instance. For a separate Device Object Instance value, set using a non-zero value for drive parameter 5311.

Automatic Baud Rate Detection

Set the communication baud rate using drive parameter 5303. However, this value is “overridden” if automatic baud rate detection is enabled and a different baud rate is detected. By default, autobaud detection is disabled – enable by setting drive parameter 5314 to 1. When autobaud detection is enabled, drive parameter 5315 displays the detected baud rate.

Note! Autobaud detection samples for, and adjusts to, only the standard MS/TP baud rates (9600, 19200, 38400 & 76800).

Max Info Frames Property

Configure the Device Object Max Info Frames property using drive parameter 5312.
Default: 5312 = 1.

Max Master Property

Configure the Device Object Max Master property using drive parameter 5313.
Default: 5313 = 127.

Statement

This statement is part of this Standard and is required for its use.

BACnet Protocol Implementation Conformance Statement	
Date:	June 1, 2004
Vendor Name:	YORK INTERNATIONAL
Product Name:	Low Voltage AC Motor Drive
Product Model Number:	AYK550
Applications Software Version:	0500
Firmware Revision:	201C
BACnet Protocol Revision:	2
Product Description:	The AYK550 is a high-performance adjustable frequency drive specifically designed for commercial automation applications. This product supports native BACnet, connecting directly to the MS/TP LAN. All standard MS/TP baud rates are supported, as well as master mode functionality. Over BACnet, the drive can be fully controlled as a standard adjustable frequency drive. In addition, up to 16 configurable I/O ports are available over BACnet for user applications.
BACnet Standardized Device Profile (Annex L):	<input type="checkbox"/> BACnet Operator Workstation (B-OWS) <input type="checkbox"/> BACnet Building Controller (B-BC) <input type="checkbox"/> BACnet Advanced Application Controller (B-AAC) <input checked="" type="checkbox"/> BACnet Application Specific Controller (B-ASC) <input type="checkbox"/> BACnet Smart Sensor (B-SS) <input type="checkbox"/> BACnet Smart Actuator (B-SA)
List all BACnet Interoperability Building Blocks Supported (Annex K):	DS-RP-B, DS-WP-B, DM-DDB-B, DM-DOB-B, DM-DCC-B, DM-RD-B.
Segmentation Capability:	<input type="checkbox"/> Segmented requests supported. Window Size ____ <input type="checkbox"/> Segmented responses supported. Window Size ____
Standard Object Types Supported: An object type is supported if it may be present in the device. For each standard Object Type supported provide the following data: 1) Whether objects of this type are dynamically creatable using the CreateObject service 2) Whether objects of this type are dynamically detectable using the DeleteObject service 3) List of the optional properties supported 4) List of all properties that are writable where not otherwise required by this standard 5) List of proprietary properties and for each its property identifier, datatype, and meaning 6) List of any property range restrictions	See table at "Object/Property Support Matrix" on page 24.

BACnet Protocol Implementation Conformance Statement	
Data Link Layer Options:	<input type="checkbox"/> BACnet IP, (Annex J) <input type="checkbox"/> BACnet IP, (Annex J), Foreign Device <input type="checkbox"/> ISO 8802-3, Ethernet (Clause 7) <input type="checkbox"/> ANSI/ATA 878.1, 2.5 Mb. ARCNET (Clause 8) <input type="checkbox"/> ANSI/ATA 878.1, RS-485 ARCNET (Clause 8), baud rate(s) ____ <input checked="" type="checkbox"/> MS/TP master (Clause 9), baud rate(s): 9600, 19200, 38400, 76800 <input type="checkbox"/> MS/TP slave (Clause 9), baud rate(s): ____ <input type="checkbox"/> Point-To-Point, EIA 232 (Clause 10), baud rate(s): ____ <input type="checkbox"/> Point-To-Point, modem, (Clause 10), baud rate(s): ____ <input type="checkbox"/> LonTalk, (Clause 11), medium: _____ <input type="checkbox"/> Other: _____
Device Address Binding: Is static device binding supported? (This is currently necessary for two-way communication with MS/TP slaves and certain other devices.)	<input type="checkbox"/> Yes <input checked="" type="checkbox"/> No
Networking Options:	<input type="checkbox"/> Router, Clause 6 - List all routing configurations, e.g., ARCNET-Ethernet, Ethernet-MS/TP, etc. <input type="checkbox"/> Annex H, BACnet Tunneling Router over IP <input type="checkbox"/> BACnet/IP Broadcast Management Device (BBMD)
Does the BBMD support registrations by Foreign Devices?	<input type="checkbox"/> Yes <input type="checkbox"/> No
Character Sets Supported: Indicating support for multiple character sets does not imply that they can all be supported simultaneously.	<input checked="" type="checkbox"/> ANSI X3.4 <input type="checkbox"/> IBM™/Microsoft™ DBCS <input type="checkbox"/> ISO 8859-1 <input type="checkbox"/> ISO 10646 (UCS-2) <input type="checkbox"/> ISO 10646 (UCS-4) <input type="checkbox"/> JIS C 6226
If this product is a communication gateway, describe the types of non-BACnet equipment/networks(s) that the gateway supports:	

Object Definitions

Object/Property Support Matrix

The following table summarizes the Object Types/Properties Supported:

Property	Object Type						
	Device	Binary Input	Binary Output	Binary Value	Analog Input	Analog Output	Analog Value
Object Identifier	✓	✓	✓	✓	✓	✓	✓
Object Name	✓	✓	✓	✓	✓	✓	✓
Object Type	✓	✓	✓	✓	✓	✓	✓
System Status	✓						
Vendor Name	✓						
Vendor Identifier	✓						
Model Name	✓						
Firmware Revision	✓						
Appl Software Revision	✓						
Protocol Version	✓						
Protocol Revision	✓						
Services Supported	✓						
Object Types Supported	✓						
Object List	✓						
Max APDU Length	✓						
Segmentation Support	✓						
APDU Timeout	✓						
Number APDU Retries	✓						
Max Master	✓						
Max Info Frames	✓						
Device Address Binding	✓						
Database Revision	✓						
Present Value		✓	✓	✓	✓	✓	✓
Status Flags		✓	✓	✓	✓	✓	✓
Event State		✓	✓	✓	✓	✓	✓
Out-of-Service		✓	✓	✓	✓	✓	✓
Units					✓	✓	✓
Priority Array			✓	✓*		✓	✓*
Relinquish Default			✓	✓*		✓	✓*
Polarity		✓	✓				
Active Text		✓	✓	✓			
Inactive Text		✓	✓	✓			

* For commandable values only.

Binary Input Object Instance Summary

The following table summarizes the Binary Input Objects supported:

Instance ID	Object Name	Description	Active/ Inactive Text	Present Value Access Type
BI0	RO 1 ACT	This point indicates the status of Relay Output 1.	ON/OFF	R
BI1	RO 2 ACT	This point indicates the status of Relay Output 2.	ON/OFF	R
BI2	RO 3 ACT	This point indicates the status of Relay Output 3.	ON/OFF	R
BI3	RO 4 ACT	This point indicates the status of Relay Output 4 (requires OREL-01 option).	ON/OFF	R
BI4	RO 5 ACT	This point indicates the status of Relay Output 5 (requires OREL-01 option)	ON/OFF	R
BI5	RO 6 ACT	This point indicates the status of Relay Output 6 (requires OREL-01 option)	ON/OFF	R
BI6	DI 1 ACT	This point indicates the status of Digital Input 1.	ON/OFF	R
BI7	DI 2 ACT	This point indicates the status of Digital Input 2.	ON/OFF	R
BI8	DI 3 ACT	This point indicates the status of Digital Input 3.	ON/OFF	R
BI9	DI 4 ACT	This point indicates the status of Digital Input 4.	ON/OFF	R
BI10	DI 5 ACT	This point indicates the status of Digital Input 5.	ON/OFF	R
BI11	DI 6 ACT	This point indicates the status of Digital Input 6.	ON/OFF	R

Note! For Present Value Access Types, R = Read-only, W = Writable, C = Commandable. Commandable values support priority arrays & relinquish defaults.

Binary Output Object Instance Summary

The following table summarizes the Binary Output Objects supported:

Instance ID	Object Name	Description	Active/ Inactive Text	Present Value Access Type
BO0	RO1 COMMAND	This point controls the output state of Relay 1. This control requires that parameter 1401 value = COMM.	ON/OFF	C
BO1	RO2 COMMAND	This point controls the output state of Relay 2. This control requires that parameter 1402 value = COMM.	ON/OFF	C
BO2	RO3 COMMAND	This point controls the output state of Relay 3. This control requires that parameter 1403 value = COMM.	ON/OFF	C

Instance ID	Object Name	Description	Active/Inactive Text	Present Value Access Type
BO3	RO4 COMMAND	This point controls the output state of Relay 4. This control requires that parameter 1410 value = COMM (also requires OREL-01 option).	ON/OFF	C
BO4	RO5 COMMAND	This point controls the output state of Relay 5. This control requires that parameter 1411 value = COMM (also requires OREL-01 option).	ON/OFF	C
BO5	RO6 COMMAND	This point controls the output state of Relay 6. This control requires that parameter 1412 value = COMM (also requires OREL-01 option).	ON/OFF	C

Note! For Present Value Access Types, R = Read-only, W = Writable, C = Commandable. Commandable values support priority arrays & relinquish defaults.

Binary Value Object Instance Summary

The following table summarizes the Binary Value Objects supported:

Instance ID	Object Name	Description	Active/Inactive Text	Present Value Access Type
BV0	RUN/STOP ACT	This point indicates the drive Run Status, regardless of the control source.	RUN/STOP	R
BV1	FWD/REV ACT	This point indicates the motor's rotation direction, regardless of the control source.	REV/FWD	R
BV2	FAULT ACT	this point indicates the drive's fault status.	FAULT/OK	R
BV3	EXT 1/2 ACT	This point indicates which control source is active: External 1 or External 2.	EXT2/EXT1	R
BV4	HAND/AUTO ACT	This point indicates whether the drive is under Hand or Auto control.	HAND/AUTO	R
BV5	ALARM ACT	This point indicates the drive's alarm status.	ALARM/OK	R
BV6	MAINT REQ	This point indicates the drive's maintenance status. Refer to Group 29 in the drive's parameter descriptions.	MAINT/OK	R
BV7	DRIVE READY	This point indicates whether the drive is ready to accept a run command.	READY/NOT READY	R
BV8	AT SETPOINT	This point indicates whether the drive is at the commanded setpoint.	YES/NO	R

Instance ID	Object Name	Description	Active/Inactive Text	Present Value Access Type
BV9	RUN ENA ACT	This point indicates the Run Enable command status, regardless of the control source.	ENABLE/ DISABLE	R
BV10	RUN/STOP CMD	This point commands a drive start. Control requires either: <ul style="list-style-type: none"> • Parameter 1001 value = COMM for control by EXT1 or • Parameter 1002 value = COMM for control by EXT2. 	RUN/STOP	C
BV11	FWD/REV CMD	This point commands a motor rotation direction change. Control requires either: <ul style="list-style-type: none"> • Parameter 1001 value = COMM for control by EXT1 or • Parameter 1002 value = COMM for control by EXT2. 	REV/FWD	C
BV12	RUN ENA CMD	This point commands Run Enable. Control requires parameter 1601 value = COMM.	ENABLE/ DISABLE	C
BV13	EXT 1/2 CMD	This point selects ext1 or ext2 as the active control source. Control requires parameter 1102 value = COMM.	EXT2/EXT1	C
BV14	FAULT RESET	This point resets a faulted drive. The command is rising-edge triggered. Control requires parameter 1604 value = COMM.	RESET/NO	C
BV15	MBOX READ	This point reads a parameter (defined by AV25 MBOX PARAM) and returns it in AV26 MBOX DATA.	READ/RESET	W
BV16	MBOX WRITE	This point writes the data value specified by AV26, MBOX DATA, to a parameter (defined by AV25, MBOX PARAM).	WRITE/RESET	W
BV17	LOCK PANEL	This point locks the panel and prevents parameter changes. The corresponding drive parameter is 1602.	LOCK/UNLOCK	W
BV18	CTL OVERRIDE CMD	This point commands the drive into BACnet Control Override. In this mode, BACnet takes drive control from the normal source. However, the control panel's HAND mode has priority over BACnet Control Override.	ON/OFF	C

Instance ID	Object Name	Description	Active/Inactive Text	Present Value Access Type
BV19	CTL OVERRIDE ACT	This point indicates whether the drive is in BACnet Control Override. (See BV18.)	ON/OFF	R

Note! For Present Value Access Types, R = Read-only, W = Writable, C = Commandable. Commandable values support priority arrays & relinquish defaults.

Analog Input Object Instance Summary

The following table summarizes the Analog Input Objects supported:

Instance ID	Object Name	Description	Units	Present Value Access Type
AI0	ANALOG INPUT 1	This point indicates the value of Analog Input 1. The corresponding drive parameter is 0120.	Percent	R
AI1	ANALOG INPUT 2	This point indicates the value of Analog Input 2. The corresponding drive parameter is 0121.	Percent	R

Note! For Present Value Access Types, R = Read-only, W = Writable, C = Commandable. Commandable values support priority arrays & relinquish defaults.

Analog Output Object Instance Summary

The following table summarizes the Analog Output Objects supported:

Instance ID	Object Name	Description	Units	Present Value Access Type
AO0	AO 1 COMMAND	This point controls Analog Output 1. The corresponding drive parameter is 0135, COMM VALUE 1. Control requires parameter 1501 value = 135.	Percent	C
AO1	AO 2 COMMAND	This point controls Analog Output 2. The corresponding drive parameter is 0136, COMM VALUE 2. Control requires parameter 1507 value = 136.	Percent	C

Note! For Present Value Access Types, R = Read-only, W = Writable, C = Commandable. Commandable values support priority arrays & relinquish defaults.

Analog Value Object Instance Summary

The following table summarizes the Analog Value Objects supported:

Instance ID	Object Name	Description	Units	Present Value Access Type
AV0	OUTPUT SPEED	This point indicates the calculated motor speed in RPM. The corresponding drive parameter is 0102.	RPM	R
AV1	OUTPUT FREQ	This point indicates the output frequency applied to the motor in Hz. The corresponding drive parameter is 0103.	Hertz	R
AV2	DC BUS VOLT	This point indicates the drive's DC bus voltage level. The corresponding drive parameter is 0107.	Volts	R
AV3	OUTPUT VOLT	This point indicates the AC output voltage applied to the motor. The corresponding drive parameter is 0109.	Volts	R
AV4	CURRENT	This point indicates the measured output current. The corresponding drive parameter is 0104.	Amps	R
AV5	TORQUE	This point indicates the calculated motor output torque as a percentage of nominal torque. The corresponding drive parameter is 0105.	Percent	R
AV6	POWER	This point indicates the measured output power in kW. The corresponding drive parameter is 0106.	Kilowatts	R
AV7	DRIVE TEMP	This point indicates the measured heatsink temperature in °C. The corresponding drive parameter is 0110.	°C	R
AV8	KWH (R)	This point indicates, in kW hours, the drive's accumulated energy usage since the last reset. The value can be reset to zero. The corresponding drive parameter is 0115.	kWh	W
AV9	KWH (NR)	This point indicates the drive's accumulated energy usage in kW hours. The value cannot be reset.	kWh	R
AV10	PRC PID FBCK	This point is the Process PID feedback signal. The corresponding drive parameter is 0130.	Percent	R
AV11	PRC PID DEV	This point is the Process PID output signal's deviation from its setpoint. The corresponding drive parameter is 0132.	Percent	R
AV12	EXT PID FBCK	This point is the External PID feedback signal. The corresponding drive parameter is 0131.	Percent	R
AV13	EXT PID DEV	This point is the External PID output signal's deviation from its setpoint. The corresponding drive parameter is 0133.	Percent	R
AV14	RUN TIME (R)	This point indicates, in hours, the drive's accumulated run time since the last reset. The value can be reset to zero. The corresponding drive parameter is 0114.	Hours	R

Instance ID	Object Name	Description	Units	Present Value Access Type
AV15	MOTOR TEMP	This point indicates the drive's motor temperature, as set up in parameter Group 35. The corresponding drive parameter is 0145.	°C	R
AV16	INPUT REF 1	This point sets Input Reference 1. Control requires parameter 1103 value = COMM.	Percent	C
AV17	INPUT REF 2	This point sets Input Reference 2. Control requires parameter 1106 value = COMM.	Percent	C
AV18	LAST FLT	This point indicates the most recent fault entered in the drive's fault log. The corresponding drive parameter is 0401.	None	R
AV19	PREV FLT 1	This point indicates the second most recent fault entered in the drive's fault log. The corresponding drive parameter is 0412.	None	R
AV20	PREV FLT 2	This point indicates the third most recent fault entered in the drive's fault log. The corresponding drive parameter is 0413.	None	R
AV21	AO 1 ACT	This point indicates Analog Output 1's level. The corresponding drive parameter is 0124.	Milliamps	R
AV22	AO 2 ACT	This point indicates Analog Output 2's level. The corresponding drive parameter is 0125.	Milliamps	R
AV23	ACCEL1 TIME	This point sets the Ramp1 acceleration time. The corresponding drive parameter is 2202.	Seconds	W
AV24	DECEL1 TIME	This point sets the Ramp1 deceleration time. The corresponding drive parameter is 2203.	Seconds	W
AV25	MBOX PARAM	This point defines the parameter to be read or written to by the mailbox function. See BV15 and BV16.	None	W
AV26	MBOX DATA	This point holds the mailbox function's parameter value – a value that was read, or is to be written. See BV15 and BV16.	None	W
AV27	EXT PID STPT	This point sets the External PID controller setpoint. The corresponding drive parameter is 4211. Control requires parameter 4210, PID SETPOINT SEL, value = 19 (INTERNAL).	Percent	C

Note! For Present Value Access Types, R = Read-only, W = Writable, C = Commandable. Commandable values support priority arrays & relinquish defaults.

Index

<p style="text-align: center;">A</p> <p>autobaud detection 20</p>	<p style="text-align: center;">I</p> <p>installation 7</p>
<p style="text-align: center;">B</p> <p>baud rate detection 20</p> <p>bus connections 8</p>	<p style="text-align: center;">M</p> <p>mac id 20</p> <p>mailbox, EFB comm 15</p> <p>max info frame property 21</p>
<p style="text-align: center;">C</p> <p>comm (EFB) analog output control, activate 14</p> <p> comm fault response 15</p> <p> configuration 10</p> <p> configure for loss of communication 18</p> <p> control interface 7</p> <p> drive control of functions, activate 13</p> <p> fault code 28 18</p> <p> fault code 31 18</p> <p> fault code 32 18</p> <p> fault code 33 18</p> <p> fault tracing parameters 17</p> <p> fault, duplicate stations 18</p> <p> fault, intermittent off-line 19</p> <p> fault, no master station on line 18</p> <p> fault, swapped wires 18</p> <p> feedback from drive 15</p> <p> feedback from drive, mailbox 15</p> <p> input ref. sel., activate 13</p> <p> mailbox, param. read/write 15</p> <p> misc. drive control, activate 13</p> <p> normal operation 17</p> <p> PID control setpoint source, activate 14</p> <p> relay output control, activate 14</p> <p> setup 10</p> <p> start/stop control, activate 13</p> <p> termination 8</p> <p>connections bus 8</p>	<p style="text-align: center;">N</p> <p>network planning 8</p>
<p style="text-align: center;">D</p> <p>data link layer 20</p> <p>diagnostics 17</p> <p>drive bus connections 8</p>	<p style="text-align: center;">O</p> <p>object analog inputs 28</p> <p> analog outputs 28</p> <p> analog values 29</p> <p> binary inputs 25</p> <p> binary outputs 25</p> <p> binary values 26</p> <p> definitions 24</p>
<p style="text-align: center;">F</p> <p>fault comm failure (EFB) 15</p> <p>fault code 28 serial 1 err 18</p>	<p style="text-align: center;">P</p> <p>pics statement 22</p> <p> summary 20</p> <p>PID setpoint source, EFB comm activate 14</p> <p>planning 8</p> <p>protocol implementation conformance statement see pics</p>
<p style="text-align: center;">G</p> <p>group 53 parameters 29</p>	<p style="text-align: center;">Q</p> <p>quick-start sequence 10</p>
<p style="text-align: center;">R</p> <p>RS485 comm 8</p>	<p style="text-align: center;">S</p> <p>serial 1 error (fault code 28) 18</p> <p>services supported 20</p> <p>start control, EFB comm 13</p> <p>start-up 10</p> <p>support matrix 24</p>
<p style="text-align: center;">T</p> <p>technical data 20</p> <p>termination 8</p>	

