



Trane Classic[®] Absorption Series

**Single-Stage Hot Water or
Steam-Fired Absorption Water Chillers
112-465 Tons**

Built for Industrial and Commercial Applications



Introduction



History of Trane Absorption Chillers

Trane has been the leader in absorption chiller design and manufacturing for 40 years. Dedicated to the advancement of absorption chiller technology, Trane is the only North American chiller manufacturer to commercialize double effect absorption over 25 years ago. Since then, Trane has manufactured and shipped over 10,000 absorbers to commercial, industrial and process applications worldwide. Innovations such as microelectronic controls, adaptive frequency drives and smart purge systems have modernized the technology, making it more capable, more reliable and in many applications, more economical.

Contents

Introduction	2
Features and Benefits Component Identification, Typical Single-Stage Steam Illustration, Refrigerant Cycle Overview	4
Application Considerations Operating Limits, Sound, Water Flow/Treatment, Combination Systems, Multiple Machines	7
Selection Procedure Computer Selection Procedure, Tube Fouling	8
Performance Data Capacity/COP/Steam Rate/Flow Rate, Pressure Drop Tables, Capacity vs. Chilled Water Supply Temperature, Energy Input vs. Capacity, Pressure Drop vs. Flow Rate	9
Electrical Data	11
Controls Data	12
Dimensions and Weights Physical Dimensions, Weights, Connection Sizes, Refrigerant Charging, Separated Machine Sections, Foundation Support, Rigging/Service Clearances, Chiller Isolation, Insulation Lengths	16
Jobsite Connections Typical Piping	20
Mechanical Specifications	25
Standard Conversion Table	27



Features and Benefits

General

Why Trane Absorption Makes Sense

Engineers and owners who are planning new chiller plants, expanding systems or processes, or replacing older refrigeration equipment, are more often considering the absorption option. The use of absorption chillers is on the rise due to their increased reliability and the benefits of hybrid chiller plant design. The absorption chiller has earned the reputation as a viable alternative to the electric chiller or in the example of a hybrid installation, a viable counterpart to the electric chiller.

Operates With Either Water or Steam Source

Absorption is particularly appropriate in cooling applications where there is a low-pressure steam or hot liquid source, a waste heat recovery option, or in areas where electric rates or demand charges are high. The Trane Classic single-stage absorption chiller is designed to use steam at pressures up to 14 psig and at temperatures to 340°F, or hot water temperatures up to 270°F. These chillers are ideal for situations requiring chilled water in the range of 40-50°F. They are a popular choice when an economic comparison of electrical rates versus fuel costs indicates an operating cost advantage for absorption.

The Classic single-stage absorption chiller features a time-tested design along with continuing advancements in component metallurgy and systems controls and control logic. This single-stage design is ideally suited for applications with low pressure steam or pressurized hot water. They are available in sizes from 112 to 465 tons and can be used in a wide range of process and comfort cooling applications, using either hot water or steam as an energy input. The chiller is a hermetic design and comes with a factory-mounted microprocessor-based control system. Units are available in voltages of 200, 380, 415, 460 or 575 VAC for either 60 or 50 Hz operation.

A full range economizer is standard for these units to precisely match the solution flow in proportion to the cooling



load on the machine. This reduces the amount of heat input required and can result in significant operating economies.

Ships Completely Assembled

All Trane single-stage absorption units are fully assembled in the factory and ship in one piece. When they arrive at the jobsite, they are ready to be set in place. In addition to simplified installation, full factory assembly makes it possible for the customer to benefit from a stringent factory mass spectrometer leak test.

The units are shipped under a vacuum to assure that hermetic integrity is maintained through installation. By comparing machine vacuum at the jobsite with the factory record, the contractor and owner can be confident that there has been no damage to the machine and it is airtight, dry and clean.

Low Temperature Input Designs

Making chilled water from comparatively low temperature inputs is particularly important for energy conserving applications such as waste heat recovery and co-generation equipment and solar energy powered cooling. The same reliability and performance proven in thousands of conventional applications

can be expected in low temperature applications.

Concentration Limit Control

A positive concentration limit (PCL) control is standard on all unit sizes. This system is designed to detect conditions where crystallization might occur and automatically pump dilute refrigerant into the system, and if crystallization continues, shut down the machine. This is valuable if the machine operates unattended and electrical power interruptions are common. It protects the machine from possible damage in the event the machine does not have the opportunity to go through the normal dilution cycle at shutdown.

UCP2™ Control Panel

The Classic absorption chiller is equipped with Trane's exclusive UCP2 control panel which includes microprocessor control capability and extensive unit diagnostics. It allows the chiller to continue to operate through a broad range of non-standard conditions, keeping chilled water supplied as long as possible. The unit diagnostics available as part of this control simplify troubleshooting and allow more efficient scheduled preventive maintenance.

Features and Benefits

General

The Absorption Refrigeration Cycle

The absorption cycle uses water as the refrigerant and heat as the energy input to create chilled water for comfort or process applications. In the absorption cycle, steam or hot water is used to boil a dilute solution of lithium bromide and water in a hermetic vessel. The water vapor produced is drawn through the condenser, where it gives up heat to the cooling tower water and through the absorption process, cools the system circulating water. This process is illustrated in the flow diagram on the reverse side.

Built/Designed In An ISO 9001 Quality Certified Facility

Trane absorption machines are built in an ISO 9001 quality certified facility in La Crosse, WI.

All Trane chillers include extensive aftermarket support. Training for unit operators is provided to assure that designated unit operators thoroughly understand absorption system operation and unit capabilities and limitations.

Factory-trained absorption service personnel are located throughout the country to support Trane chillers and perform periodic routine maintenance programs, as well as troubleshoot equipment if necessary. Records on the exact construction of each chiller are maintained by Trane. This assures that all appropriate parts are provided if service is necessary, and that the unit can be maintained exactly as it was intended.

Trane Absorption Leadership

Trane has been the market leader in absorption water chillers for over 40 years. The company is committed to research, development and application of absorption technology at its research facilities in La Crosse, Wisconsin. Since 1959, Trane has shipped over 10,000 absorption units for use around the world. Trane's commitment to absorption technology includes laboratory testing and factory training of technicians for start-up and warranty service and emergency service support.

Standard Specification

- Single shell design
- Long-life cupronickel tubes in the concentrator, evaporator and absorber
- Factory leak tested to help assure product integrity
- Tubes are individually replaceable from either end of machine
- Solution pump motor can be serviced without breaking vacuum or removing solution from machine
- Victaulic™ water connections
- Automatic decrystallization controls
- Start-up steam demand limit control

Optional Specification

- Special corrosion-resistant tubing
- Stainless steel evaporator pans
- Lithium bromide filter and valves
- Welded raised face flanges at all water connections
- NEMA 4 controls
- Chemically resistant epoxy paint
- Wooden pallets can be provided under each leg for handling at installation site or to facilitate international shipment

UCP2 Controls

- Improved reliability and performance
- Factory installed and commissioned
- Proportional integral derivative (PID) control. Adaptive Control™ strategies for stable, efficient, reliable and optimal chilled water temperature control
- Easy-to-use operator interface that includes
 - English or SI units
 - Standard and custom reports
 - Two-line, 40 character backlit LCD display in clear language
 - Over 200 diagnostics including time and date stamping.

Features and Benefits

Refrigeration Cycle

Classic Single-Stage Absorption Refrigerant Cycle

Refrigeration Cycle

The Trane Absorption Cold Generator® uses the proven lithium bromide and water absorption refrigeration cycle. It takes place in a sealed, hermetic vessel from which essentially all air has been evacuated. Consequently, the pressures within the shell are the vapor pressures of the liquids at their respective temperatures. In operation, the pressure in the concentrator and condenser sections is about 1/10 of an atmosphere. Pressure in the evaporator and absorber sections is about 1/100 of an atmosphere.

Generator

Heat energy from steam or hot water is used to boil a dilute solution of lithium bromide and water. This boiling results in release of water vapor, and in concentration of the remaining lithium bromide solution.

Condenser

The water, or refrigerant, vapor released in the concentrator is drawn into the condenser section. Cooling tower water flowing through the condenser tubes cools and condenses the refrigerant.

Evaporator

Liquid refrigerant flows through an orifice into the evaporator. As the refrigerant passes into the lower pressure evaporator, flashing takes place. The flashing cools the remaining liquid refrigerant to the saturation temperature of the refrigerant at the pressure present within the evaporator, approximately 40°F.

The chilled refrigerant falls into the evaporator pan and is circulated continuously to the evaporator spray trees by the evaporator pump. The sprayed refrigerant wets the evaporator tube bundle, chilling the system water within the bundle. The transfer of heat from the system water to the refrigerant causes the refrigerant to vaporize. The refrigerant vapor generated in this evaporative cooling process migrates downward to the absorber.

Figure FB-1 – Single-Stage Absorption Refrigeration Cycle

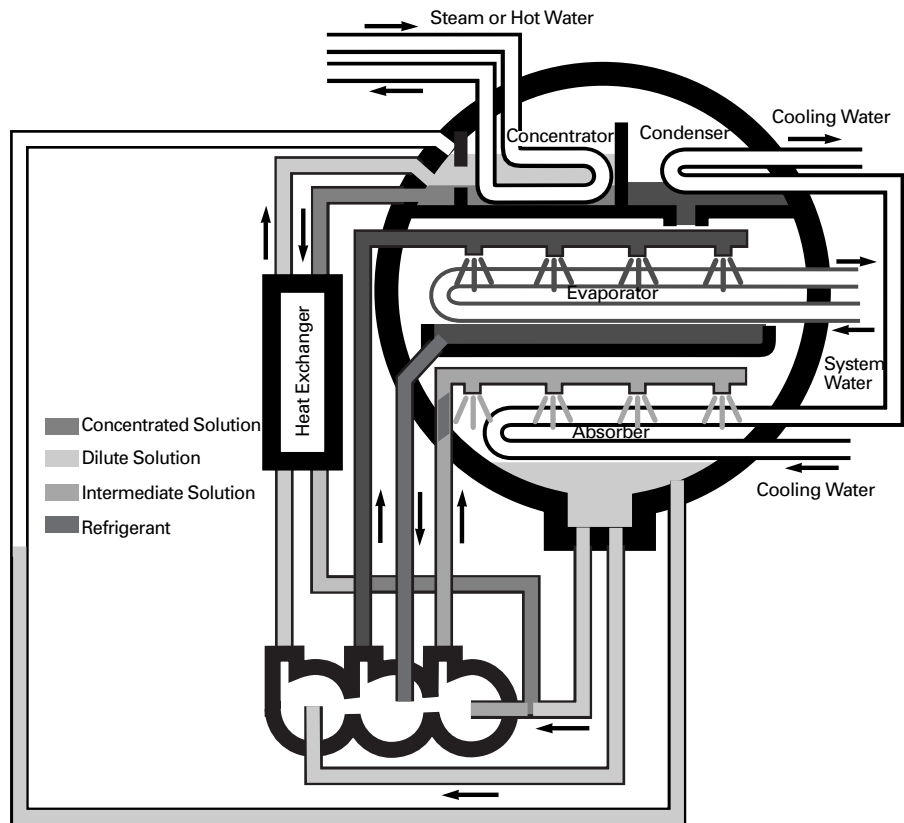

Absorber

The refrigerant vapor is drawn to the absorber section by the low pressure resulting from absorption of the refrigerant into the absorbent. In order to expose a large amount of lithium bromide solution surface to the water vapor, the solution is sprayed over the absorber tube bundle. Cooling tower water is used in this tube bundle to remove the heat of absorption that is released when the refrigerant vapor returns to the liquid state.

As the absorbent absorbs refrigerant vapor, the solution becomes increasingly dilute. It is necessary to continuously circulate this dilute solution back to the concentrator to keep the cycle continuous.

Solution Heat Exchanger

The heat exchanger exchanges heat between the relatively cool, dilute solution being transferred from the absorber to the concentrator section and the hot, concentrated, solution being returned from the concentrator to the absorber. Transferring heat from the concentrated solution to the dilute solution reduces the amount of heat that must be added to bring the dilute solution to a boil. Simultaneously, reducing the temperature of the concentrated solution decreases the amount of heat that must be removed from the absorber section. Efficient operation of the heat exchanger is extremely important to the economical operation of the lithium bromide-water cycle.

Application Considerations

General

General

The Classic single-stage steam-fired or hot water absorption chiller is designed to provide 40°F to 60°F (4.4°C - 15.6°C) chilled water for comfort or process cooling applications within all three market segments – commercial, industrial and institutional. They are most often used where an economic analysis of fuel costs versus electrical rates indicates an operating cost advantage.

In many process applications, they can be utilized to convert excess heat energy to provide chilled water for process or comfort applications.

Operating Limits

Classic single-stage absorption chillers operate with nominal 13 psig (0.83 bar) steam or nominal 270°F (132°C) hot water. In all applications, superheat should be limited so steam temperature does not exceed 340°F (171°C).

Water flows within the limits indicated on the appropriate selection table will ensure tube water velocities not exceeding 10 feet per second (3.05 m/sec) in copper tubes and 11 feet per second (3.35 m/sec) in cupronickel tubes. Changes in condenser water temperature should not exceed 1-degree F per minute between the range of 75-95°F (23.9°C - 35°C).

Sound and Vibration

Absorption units are well-suited for areas where low sound levels are required. The Trane Classic single-stage steam absorption chiller will operate under normal load conditions at less than 85 dBA sound pressure level. During operation there is no vibration of any components that could be damaging to the chiller or could transmit objectionable sound or vibration to the building.

Chiller Installation

The following should be taken into consideration when installing an absorption chiller:

- Rigging and service clearances
- Foundation support
- Chiller isolation for sound/vibration reduction
- Condensate handling
- Steam supply control
- Condenser water temperature control
- Chilled water flow control
- Chilled and condenser water flow limit
- Generator hot water application

Water Treatment

The use of untreated or improperly treated water may result in scaling, erosion, and corrosion, algae or slime. It is recommended that the services of a qualified water treatment specialist be used to determine what treatment, if any is advisable. The Trane Company assumes no responsibility for the results of untreated, or improperly treated water.

Combination Systems

Peak energy savings can be achieved when using a combination of electric chillers and absorption chillers for air conditioning loads. The absorption chiller is used to shave seasonal billable peak power demands during summer operation, and the electric chiller is run below the allowed demand limit, reducing costly demand charges. Trane offers both electric chillers and absorption chillers with the unit control panel (UCP2) as standard. Although the chillers have different features and modes of operation, the chiller control panel looks and acts the same across all chiller lines. Each control panel is programmed to monitor the particular chiller for which it was designed but maintenance and service personnel need only become familiar with one control panel. Combined with a Trane Tracer® system a chiller plant has almost unlimited operational flexibility and all equipment is supplied from a single source.

Multiple Machine Installations

The Trane absorption machine can be applied to series or parallel chilled water flow depending upon the design requirement. Which arrangement is best for an individual system should be based on an analysis of system water and temperature rise requirements, system and machine pressure drop characteristics, and installation cost.

Parallel flow allows minimum chilled water pressure drop through the machines. However, with one machine "off," it is not usually possible to maintain the design chilled water temperature unless one machine is valved-off and the chilled water flow decreased.

Series flow permits design chilled water temperature at light loads with one machine "off." However, at all operating conditions, the chilled water pressure drop through the machine is high.

Accurate chilled water temperatures can be maintained on individual machines between 100 percent and 10 percent of nominal chiller load which allows for a wide range of control options. Each chiller has a stand-alone control system to manage the desired water temperature and also the ability to receive remote commands to support various system demands from a control center. This versatility of control makes the management of more than one machine relatively easy.



Selection Procedure

Selection Procedure

Absorption refrigeration machines are usually selected to provide required refrigeration capacity with the smallest practical machine of sufficient size. Machine size is based on chilled water flow rates and temperatures specified for the air side of the system.

Total air conditioning system first cost can be minimized by a careful analysis of system operating parameters. The effect of flow rates and temperatures, on both the building air side and the refrigeration machine selections, should be investigated to establish the system that represents the best investment for the owner.

The information on the following pages provides performance data at ARI standard conditions for: capacity in tons, efficiency, flow rates, and water pressure drops. All capacities are in accordance with ARI 560 Standard and based on fouling factors of .00025 for the evaporator waterside tubing and .00025 for the absorber and condenser tubing.

Standard Fouling

Unit performance at non-standard fouling factors may vary from standard performance. Fouling factors estimate the heat transfer penalty that anticipates the effect of typical fouling in evaporator and absorber/condenser (cooling) water circuits. All selections should use the standard fouling factor to better estimate the chiller performance in an equipment room and to comply with ARI 560.

ARI Standard Fouling Factors

Evaporator/Condenser/Absorber
English Units – hr-ft²-F/Btu
0.00025
SI Units – m²-K/kW
0.044

Additional Fouling

Any selection that uses a fouling factor above 0.00025 is a more conservative estimate that should only be used if there is an abnormal amount of fouling contaminants in the water systems. ARI 560 Standard defines “additional fouling” as “Conditions such as water hardness, organic material, suspended solids and/or water velocity may necessitate the use of a greater field fouling allowance than that provided in the Standard Rating of equipment.” The Trane single-stage Classic (ABSC) Selection program should be used to determine the effect of nonstandard fouling factors. The following guidelines can be used for estimation prior to the selection:

Additional Fouling Guidelines

Evaporator/Condenser/Absorber
English Units – hr-ft²-F/Btu
0.00026 – 0.00075
SI Units – m²-K/kW
0.046

Part Load Performance

The Classic (ABSC) single-stage absorption chiller exhibits excellent part load performance characteristics. Air conditioning system loads are usually significantly less than full load design conditions. Therefore, the absorption chiller operates at full load a small percentage of the time. Part load absorption chiller operation is normally associated with reduced tower water temperatures. At part load operation, the heat rejected to the cooling tower is less than at full load operation. Also, part load operation is typically associated with reduced outside wet bulb temperatures, resulting in improved cooling tower performance. The net result of less heat rejection and lower wet bulb temperature is cooler tower water entering the chiller and improved unit performance.

Final Selection

A final selection must be done by the local Trane sales engineer using the Classic (ABSC) Single-Stage Absorption Selection Program. For application over 1600 feet (500 meters) above sea level, final selection requires review by Absorption Product Marketing. Prior to accessing the computer selection program, the following data inputs should be tabulated:

- Temperature or pressure of the hot water or steam
- Two of the following three values must be given¹:
 - Evaporator Delta T
 - Evaporator Flow
 - Cooling Capacity
- Leaving Evaporator Water Temperature
- Entering Absorber Water Temperature
- Cooling Water Flow
- Fouling factors, evaporator and tower water

Other options that may also be selected are:

- Type and thickness of tube material
- Type of solution flowing through the evaporator and tower loop².

¹ Any limitations or restrictions should also be given (i.e., pressure drop, gpm, etc.).

² Absorption chillers can be selected with a wide variety of media other than water (evaporator and absorber/condenser, or both). For media other than water, contact the local Trane sales office for chiller selections and information.



Performance Data

Table PD-1 — Performance Data at ARI Conditions

English Units*							
Model	Capacity (Tons)	Coefficient of Performance	Steam Rate (lbm/ton/hr)	Chilled Water		Cond/Abs Water	
				Flow Rate (gpm)***	Press. Drop (ft Wtr)	Flow Rate (gpm)***	Press. Drop (ft Wtr)
112	107.9	0.63	20.15	258	28.7	403	25.5
129	126.3	0.63	20.16	302	26.3	464	34.3
148	146.4	0.63	20.18	350	38	533	28.1
174	162.7	0.64	19.77	389	27.1	626	32.3
200	188.6	0.64	19.73	451	33	720	26
228	219	0.64	19.77	524	28.2	821	36
256	246.8	0.64	19.77	590	37.7	922	24.9
294	287.3	0.64	19.8	687	31.5	1058	35.1
354	338.2	0.61	20.74	809	21.1	1274	29.7
385	368	0.64	19.6	880	28.1	1386	29.5
420	398.7	0.64	19.6	954	18.6	1512	23.4
465	444.1	0.64	19.8	1063	19	1674	24.1

SI Units**							
Model	Capacity (kW)	Coefficient of Performance	Steam Rate (kg/kW-hr)	Chilled Water		Cond/Abs Water	
				Flow Rate (m ³ /hr)	Press. Drop (m wg)	Flow Rate (m ³ /hr)	Press. Drop (m wg)
112	380	0.63	2.60	58.6	8.75	91.5	7.78
129	444	0.63	2.60	68.6	8.02	105.3	10.46
148	515	0.63	2.60	79.5	11.59	121.0	8.57
174	572	0.64	2.55	88.3	8.27	142.1	9.85
200	663	0.64	2.55	102.4	10.07	163.4	7.93
228	770	0.64	2.55	118.9	8.60	186.4	10.98
256	868	0.64	2.55	133.9	11.50	209.3	7.59
294	1011	0.64	2.55	155.9	9.61	240.2	10.71
354	1190	0.61	2.68	183.6	6.44	289.2	9.06
385	1294	0.64	2.53	199.8	8.57	314.6	9.00
420	1402	0.64	2.53	216.6	5.67	343.2	7.14
465	1562	0.64	2.55	241.3	5.80	380.0	7.35

*3.6 gpm/nominal ton, Pstm = 12 psig, TctwS = 85°F, TcwS = 44°F, TcwR = 54°F, 0.00025 evap. fouling, 0.00025 cond/abs fouling
 **23 m³/nominal kWh, Pstm = 0.83 bar, TctwS = 29.4°C, TcwS = 6.67°C, TcwR = 12.2°C, 0.044 evap fouling, 0.044 cond/abs fouling

Pstm – Steam Pressure
 TctwS – Cooling Tower Water Supply Temperature
 TcwS – Chilled Water Supply Temperature
 TcwR – Chilled Water Return Temperature



Performance Data

Figure PD-1 — ABSC Part Load Performance – Energy Input vs. Capacity at Various Cooling Water Supply Temperatures; Chilled Water Supply Temperature = 44°F (7°C) (Fixed Chilled Water Flow) without Economizer

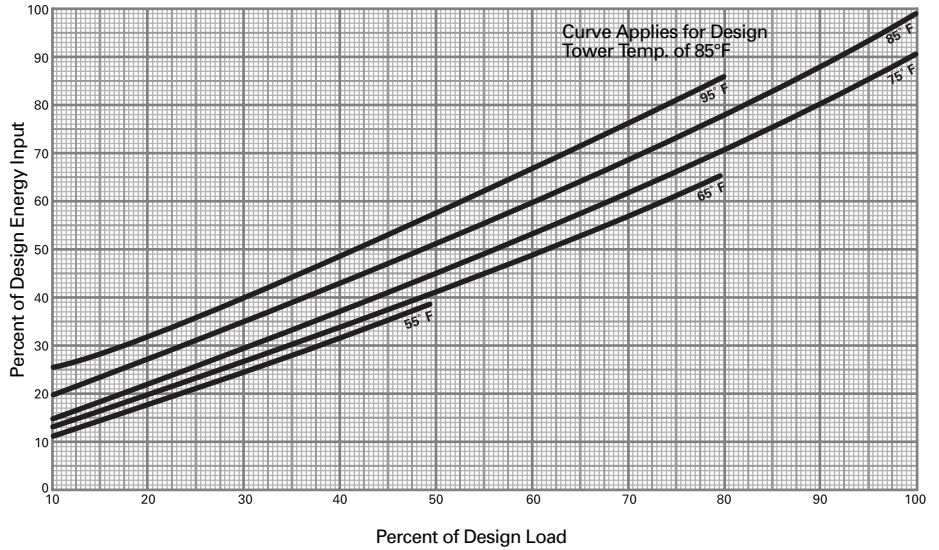
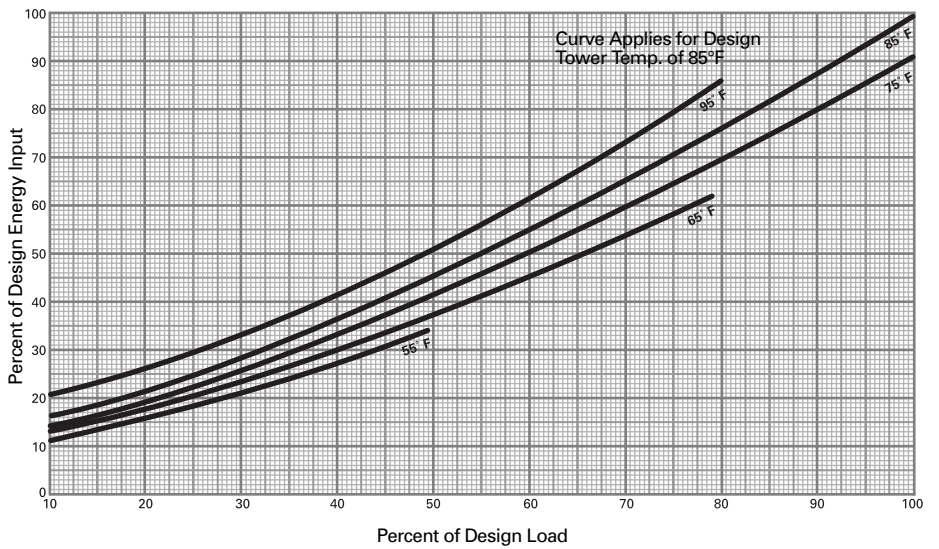

Figure PD-2 — ABSC Part Load Performance – Energy Input vs. Capacity at Various Cooling Water Supply Temperatures; Chilled Water Supply Temperature = 44°F (7°C) (Fixed Chilled Water Flow) with Economizer



Electrical Data

Electrical Data

Factory wired and mounted power control includes main power connections. Total kW includes solution and refrigerant pump, motors, purge pump motor and control panel. Units may be supplied for operation on 230,460 or 575 volt, 3 phase, 60 hertz power or 190, 220, 380, 415, 3 phase, 50 hertz power.

Table ED-1 – Electrical Data

60 Cycle, 3-Phase							
Model	Supply Voltage	FLA	Total Motor HP	Total Motor kW	Control Circuit Amps	MCA	Max Fuse Size Amps
112	200	27.8	7.5	6.4	4.0	40	45
thru	230	27.0	7.5	6.4	3.0	33	40
465 Tons	460	13.5	7.5	6.4	2.0	20	25
	575	*	7.5	6.4	1.0	*	*
Model	Supply Voltage	FLA	Total Motor HP	Total Motor kW	Control Circuit Amps	MCA	Max Fuse Size Amps
112	190	24.4	7.5	6.4	4.0	36	40
thru	220	29.0	7.5	6.4	3.0	39	40
174 Tons	380	12.2	7.5	6.4	2.0	18	20
	415	13.3	7.5	6.4	2.0	20	25
200	190	58.6	15.0	12.0	4.0	79	80
thru	220	65.6	15.0	12.0	3.0	85	90
465 Tons	380	29.3	15.0	12.0	2.0	40	45
	415	30.8	15.0	12.0	2.0	41	45

*Consult Factory

FLA = Full Load Amps

MCA = Minimum Capacity Amps

Controls Data

Setting The Standards

Trane sets the standard for unit microprocessor controls.

- Proportional Integral Derivative (PID) control strategies which provide stable operation and high accuracy for better performance along with feed forward plus.
- Adaptive Control™ to keep the chiller “on line” and at the same time keep the chiller away from a major failure;
- Software based safeties that do not depend on electromechanical hardware – hardware that means questionable reliability and added cost;
- Operator interface that accesses chiller information and control adjustments at the front of the panel.

Trane UCP2™ Unit Control Panel

UCP2 adds more flexibility, more reliability and better system performance than even our most demanding customers expect.

Flexibility

Trane offers the ability to adapt to changes easily and effectively without adding prohibitive cost. To provide flexibility, the controller responds to a wide variety of needs for:

- **System Designs** including equipment, operating conditions, and controls variations that are either existing or being considered for new installations.

Key to designing non-traditional systems is the ability to evaluate the cost and reliability issues of these systems in comparison to the more traditional systems. Trane recommends the use of C.D.S. Network Equipment Economics, the Trane Applications Manuals, and consultation with a Trane sales engineer for help in this analysis.

- **System Upgrades** including the ability to accommodate changes in the chilled water system design or equipment room requirements or to accommodate new technologies that become available.

Flexibility

- Modular structure of the UCP2 makes it possible for the designer to select the system controls and associated interfaces to Tracer® (or other building automation systems) that are required for the chiller plant design. With this modular concept, capability can be added or upgraded at any time — with only temporary interruption of chilled water production.
- The operator can quickly program a Custom Report — so that only what is considered to be the most frequently accessed/important reports are available — at any time, right at the front of the panel.
- With easy front panel programmability of Daily, Service Start-up and Machine Configuration settings and setpoints, the operator, serviceman, and system designer can customize the use of the micro controller to unique conditions of the chiller plant — whether the purpose of chilled water is for comfort cooling or for process cooling.
- All data that is necessary for the safe operation and easy serviceability of the chiller is provided as standard on all Classic absorption chillers. Options are available that provide additional controls/data that are required for: an industrial/process system design, applications outside of the typical chilled water system design, the need for redundant machine protection, or the desire for more system information.

Controls Data

Reliability

To most people, reliability means “dependable — giving the same result on successive trials.” However, to our customers it has come to mean “keep chilled water flowing.” In other words, “when I turn the switch on — cold water comes out.” In order to do this, the micro controller must be aware of what is happening in the system. But more importantly, it must be able to make decisions and adjustments to keep the chiller running as long as possible even when non-standard conditions exist. Conditions such as bad power or bad water (flow, temperature, fouling) or system component failure. Also the Trane UCP2 panel continuously monitors for noncondensables and purges automatically.

- With Enhanced Adaptive Control™ the controller does everything it can to avoid taking the chiller off line.
 - Senses evaporator temperature limit and high temperature limit
 - Displays a warning message about the potential condition/safety trip
 - Take the following corrective action sequentially as the condition worsens:
 - limits loading
 - prevents further loading
 - unloads until condition improves
 - takes chiller off line
- With more diagnostics and diagnostic history that are time/date stamped and with help messages, the operator or serviceman can take faster and more effective corrective action.

System Performance

“Chilled Water System” encompasses many levels of control: Standalone Chiller, Chiller Plant, Applied System, Central Building Automation System. However, regardless of the system level being design, the unit controls become critical not just in making every level operate reliably but in facilitating optimal performance. UCP2 provides more capability and more intelligence to make this operation/optimization possible.

Panel Features:

The absorption chiller Unit Control Panel (UCP2) incorporates the following features and components:

Control Functions

- Smart dilution cycle duration based on system requirements
- Adaptive evaporator leaving fluid temperature control
- Low evaporator temperature limit
- High solution temperature limit
- Solution flow control via AFD
- Softloading
- Nuisance trip prevention via Adaptive Control
- Chilled water reset
- Optimum concentration control
- Crystallization recovery via SDR

Controls Data

Safeties

- Smart shutdown sequence condenser/absorber loss of flow
- Low condenser/absorber water temperature
- High pressure cutout
- Evaporator leaving fluid temperature cutout
- Motor current overload
- High motor winding temperature
- Over/under voltage (optional)
- Purge limit
- Sensor failure detection

Monitored Points

Chiller information is available at the operator interface via a clear language display. Access to the information is through four dedicated report keys: Customer, Chiller, Cycle and Pump/Purge.

Custom Report

User defined custom report (operator may choose up to 20 points — from a list of over 100 choices).

Chiller Report

Status, fluid temperatures, and setpoints:

- Operating mode (i.e. run status)
- Chilled water setpoint
- Outdoor air temperature (optional)
- Chilled water reset
- Evaporator leaving water temperature
- Evaporator entering water temperature
- Absorber entering water temperature
- Absorber leaving water temperature
- Condenser leaving water temperature

Cycle Report

Refrigerant temperatures and pressures:

- Solution temperature leaving generator
- Solution temperature entering generator
- Generator leaving concentration
- Generator cutout and monitor temperature
- Crystallization detection temperature
- Crystallization trip temperature
- Saturated condenser refrigerant temperature
- Absorber entering concentration
- LiBr crystallization margin
- Solution temperature entering absorber
- Absorber spray temperature
- Solution temperature leaving absorber
- Saturated evaporator refrigerant temperature
- Evaporator leaving water temperature
- Evaporator entering water temperature
- Absorber entering water temperature
- Absorber leaving water temperature
- Condenser leaving water temperature
- Energy input auto/manual/slaved reported command
- Generator Steam Pressure

Pump/Purge Report

- Solution pump
 - Starts and hours counters
 - Motor phase currents
 - Motor phase voltages (optional)
- Purge Pump
 - Operating mode and status
 - Refrigerant suction temperature
 - Pumpout rate
 - Total pumpout time
 - Service log

Controls Data

Diagnostics

The absorption chiller Unit Control Panel (UCP2) provides over 70 different diagnostics such as:

- Water and refrigerant/solution temperatures out of range
- Loss of system water flows
- Sensor and switch faults
- Overload trips
- Over/under voltage (optional)
- Crystallization recovery
- Emergency stop
- Loss of communication to other modules
- Motor abnormal

Operator Interface

The Trane Classic (ABSC) steam-fired absorption chiller control panel, UCP2, is easy to use, understand, access information, read, change setpoints, diagnose problems, maintain, and to reset after shutdown.

Convenience

- Enunciation of all information is at the front panel display (including power, voltage, amps, purge pressures, and number of starts data).
- Messages displayed using clear language.

Ease of Use

- Two line, 40 character display that is easy to read from within a 60 degree angle
- LCD backlight so that the display can be read in a variety of equipment room lighting
- Seven languages available
- Metric (SI) units available
- Complete character human interface available
- Keypad programmability — no manual switches or setpoint potentiometers
- Logically arranged report groups with report header and setpoint groups
- Selectable security
- Variable points updated every two seconds
- Messages that direct user to problem source via a menu item
- Purge sequence of operation

Trane ICS Compatibility

The Trane Absorption chiller control panel, UCP2, is 100 percent compatible with the Trane Integrated Comfort™ systems, ICS, UCP2 easily integrates into the Tracer® family of flexible chiller plant system controllers with a single twisted-wire pair communications cable.

For more information on the Trane absorption chiller unit control panel, please contact your local Trane sales engineer.

Dimensions and Weights

Physical Dimensions/ Service Clearances

Table DW-1 - Unit Roughing-in Dimensions

Unit	A	B	C	D	E	F	G	H**	J	JJ	K	KK	L	M**	N	P	Q	R	S	T***	U	V	W	x
ABSC112	11'1"	5'10"	7'3"	7'11"	1'8"	3'4"	2'5"	1'6"	0'8"	-	0'6"	0'9"	5'2"	1'1"	3'11"	6'4"	6'2"	9'7"	0'9"	10'10"	3'8"	2'9"	1'7"	5'11"
ABSC129	12'6"	5'10"	7'3"	9'4"	1'8"	3'4"	2'5"	1'6"	0'8"	-	0'6"	-	5'2"	1'1"	3'11"	6'4"	6'2"	11'0"	0'9"	12'4"	3'8"	2'9"	1'7"	5'11"
ABSC148	14'1"	5'10"	7'3"	10'11"	8"	3'4"	2'5"	1'6"	0'8"	-	0'11"	-	5'2"	1'1"	3'11"	6'4"	6'2"	12'7"	0'9"	13'10"	3'8"	2'9"	1'7"	5'11"
ABSC174	12'6"	6'1"	7'8"	8'9"	1'9"	3'5"	2'9"	1'7"	0'9"	-	0'7"	-	5'5"	1'2"	4'0"	6'9"	6'6"	11'0"	0'9"	12'3"	3'8"	3'2"	1'9"	6'3"
ABSC200	14'1"	6'1"	7'8"	10'4"	1'9"	3'5"	2'9"	1'7"	0'9"	-	1'0"	-	5'5"	1'2"	4'0"	6'9"	6'6"	12'7"	0'9"	14'0"	3'8"	3'2"	1'9"	6'3"
ABSC228	16'0"	6'1"	7'8"	12'3"	1'9"	3'5"	2'9"	1'7"	0'9"	-	1'0"	-	5'5"	1'2"	4'0"	6'9"	6'6"	14'6"	0'9"	15'8"	3'8"	3'2"	1'9"	6'3"
ABSC256	14'5"	6'4"	8'2"	10'0"	2'1"	3'10"	3'1"	1'10"	0'10"	-	1'2"	-	5'7"	1'4"	4'0"	6'11"	6'9"	12'7"	0'11"	13'11"	3'8"	3'6"	1'11"	6'5"
ABSC294	16'4"	6'4"	8'2"	11'10"	2'1"	3'10"	3'1"	1'10"	0'11"	-	1'2"	-	5'7"	1'4"	4'0"	6'11"	6'9"	14'7"	0'11"	15'9"	3'8"	3'6"	1'11"	6'5"
ABSC354	19'3"	6'4"	8'2"	14'9"	2'1"	3'10"	3'1"	1'10"	0'10"	-	1'2"	-	5'7"	1'4"	4'0"	6'11"	6'9"	17'5"	0'11"	18'8"	3'8"	3'6"	1'11"	6'5"
ABSC385	16'7"	7'1"	8'10"	11'11"	2'1"	4'2"	3'5"	2'0"	1'0"	-	1'4"	-	5'11"	1'4"	4'2"	7'4"	7'3"	14'6"	0'11"	15'9"	3'9"	3'10"	2'3"	6'10"
ABSC420	19'6"	7'1"	8'10"	14'10"	2'1"	4'2"	3'5"	2'0"	1'0"	-	1'4"	-	5'11"	1'4"	4'2"	7'4"	7'3"	17'5"	0'11"	18'8"	3'9"	3'10"	2'3"	6'10"
ABSC465		7'1"																						

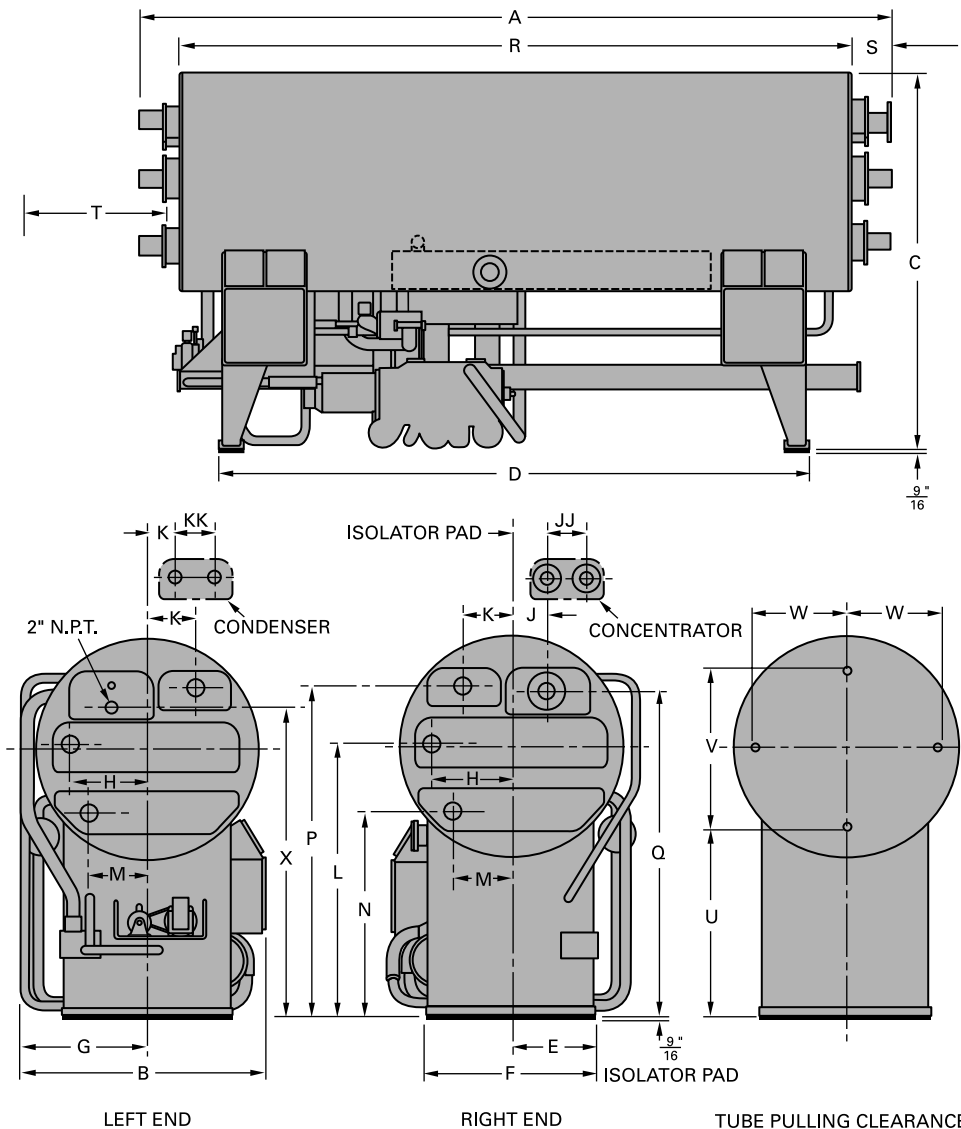

Dimensions and Weights

Service Clearances

⚠ WARNING

1. Use cables as slings only as shown. Other lifting arrangements may cause equipment damage or serious personal injury.
2. Each cable (sling) used to lift unit must be capable of supporting the entire weight of the chiller.

Figure DW-1 – Service Clearances

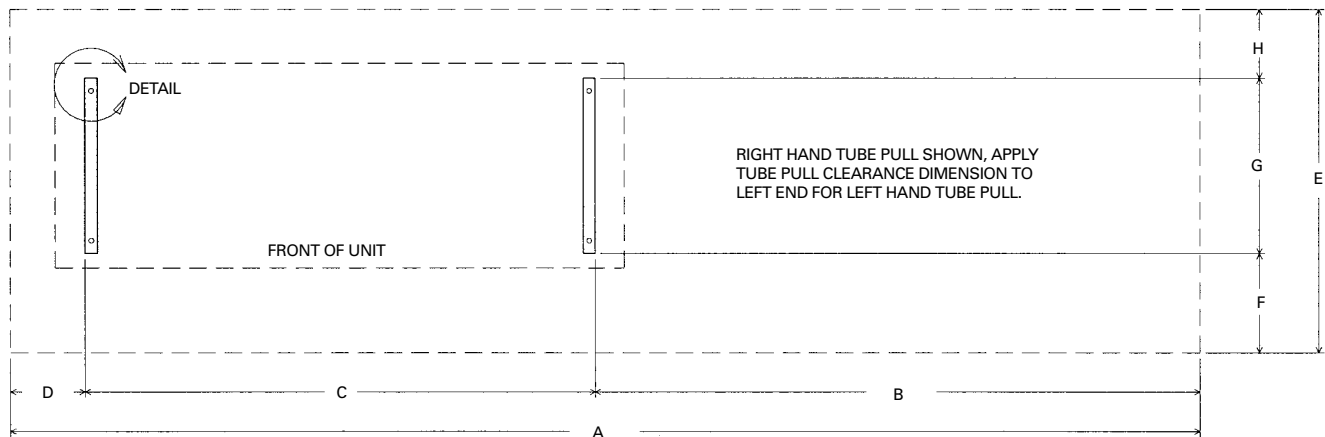
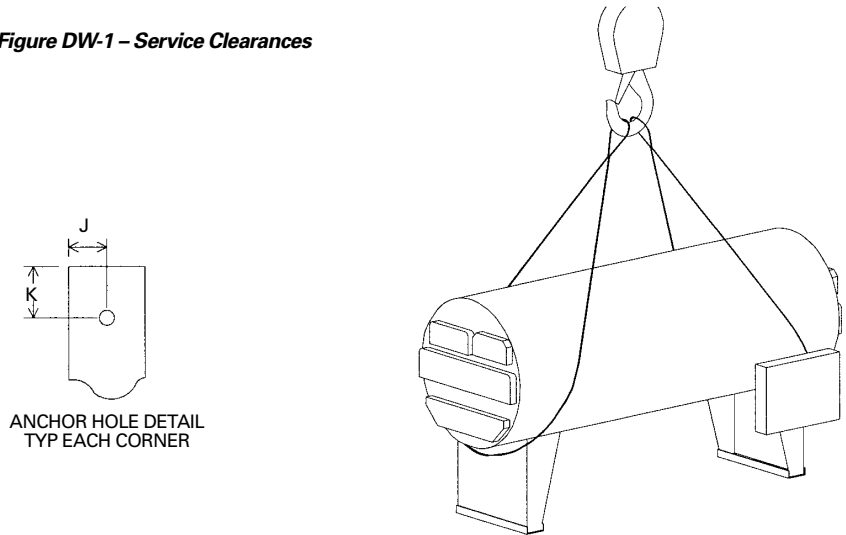

Table DW-4 – Service Clearances

Unit Size	A	B	C	D	E	F	G	H	J	K
112	23'4 3/4"	13'1 7/8"	9'4"	3'9 7/8"	10'2"	4'1"	3'4"	2'9"	2 3/8"	4 1/4"
129	26'3 3/4"	13'1 7/8"	9'4"	3'9 7/8"	10'2"	4'1"	3'4"	2'9"	2 3/8"	4 1/4"
148	29'4 3/4"	14'7 7/8"	1'	3'9 7/8"	10'2"	4'1"	3'4"	2'9"	2 3/8"	1 1/4"
174	26'2 3/4"	13'4 3/8"	8 3/4"	4'1 3/8"	10'5"	4'	3'5"	3'	2 3/8"	4 1/4"
200	29'6 3/4"	15'1 3/8"	10'4"	4'1 3/8"	10'5"	4'	3'5"	3'	2 3/8"	4 1/4"
228	33'1 3/4"	16'9 3/8"	12' 1/4"	4'1 3/8"	10'5"	4'	3'5"	3'	2 3/8"	4 1/4"
256	29'6"	15'2 1/2"	10'	4'3 1/2"	10'9"	4'	3'10"	3'	2 7/8"	5 1/2"
294	33' 1/4"	17' 1/2"	11'10"	4'3 1/2"	10'9"	4'	3'10"	3'	2 7/8"	5 1/2"
354	39'	19' 11 1/2"	14' 3/4"	4'3 1/2"	10'9"	4'	3'10"	3'	2 7/8"	5 1/2"
385	33'2"	17'	11'11"	4'3"	11'5"	3'10"	4'2"	3'5"	3"	6 3/4"
420	39'	19'11"	14'10"	4'3"	11'5"	3'10"	4'2"	3'5"	3"	6 3/4"
465	39"	19'11"	14'10"	4'3"	11'5"	3'10"	4'2"	3'5"	3"	6 3/4"



Dimensions and Weights

Insulation

Table DW-2 - Insulation Requirements

Unit	Square Feet Insulation	Unit	Square Feet Insulation
ABSC-01A, ABSC-01B, ABSC-01C, ABSC-01E	43	ABSC-05J, ABSC-06C, ABSC-070C	63
ABSC-01H, ABSC-02A, ABSC-02C	46	ABSC-08C, ABSC-09D, ABSC-11A	79
ABSC-02F, ABSC-02J, ABSC-03F	53	ABSC-12A, ABSC-14C, ABSC-16C	185
ABSC-03J, ABSC-04B, ABSC-04F, ABSC-05C	58		

Dimensions and Weights

Weights and Connection Sizes

Table DW-3— Weights and Connection Sizes

Model	English Units			
	Weights		Connection Sizes	
	Shipping [lbm]	Operating [lbm]	Cond [in]	Abs [in]
ABSC-112	8,900	11,260	3.5	4
ABSC-129	9,000	12,300	4	4
ABSC-148	10,000	13,440	4	4
ABSC-174	11,000	15,100	5	5
ABSC-200	12,000	16,350	5	5
ABSC-228	13,300	18,150	5	5
ABSC-256	15,000	19,150	6	6
ABSC-294	16,000	22,920	6	6
ABSC-354	17,000	24,700	6	6
ABSC-385	19,600	27,800	8	8
ABSC-420	22,000	30,300	8	8
ABSC-465	22,500	32,250	8	8

Jobsite Connections

Steam Supply and Condensate Piping

Steam Supply

Figure JC-1 illustrates a typical steam supply piping illustration that includes the appropriate hardware.

The steam supply piping should be designed in accordance with good design practice, providing strainers, unions and gate valves for ease of operation and maintenance. A properly sized steam modulating valve, based on design flow and pressure drop requirements, is provided by The Trane Company.

A hand valve in the steam supply piping is recommended when the machine will be out of operation for an extended period. The modulating steam valve may experience a small amount of leakage during shutdown. This leakage may result in heating of the equipment room unless the machine is properly valved off with a hand valve.

In all applications, it is recommended that the steam supply pressure to the control valve inlet not exceed design to assure proper valve close off. If steam supply pressures exceed design, a pressure reducing station should be used to control the steam pressure to the valve.

The unit control has adjustable features which minimize steam draw on start-up. The adjustable steam control feature allows the user to adapt the machine to the available steam source capability.

Figure JC-1 – Typical Steam Supply Piping

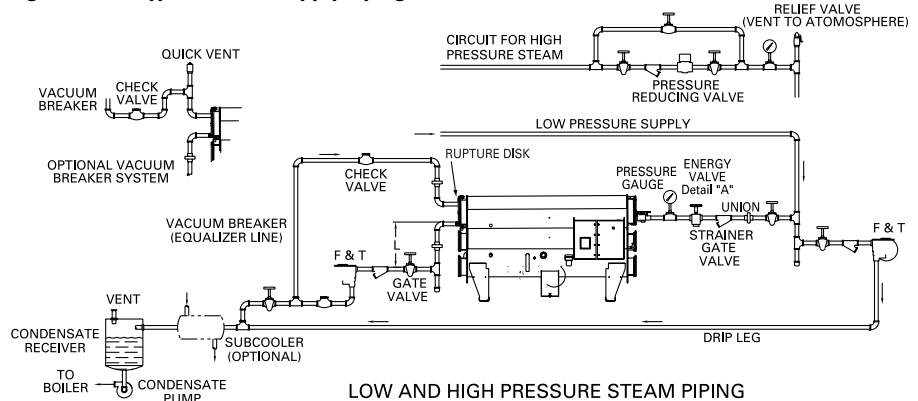

Detail "A" – Energy Valve

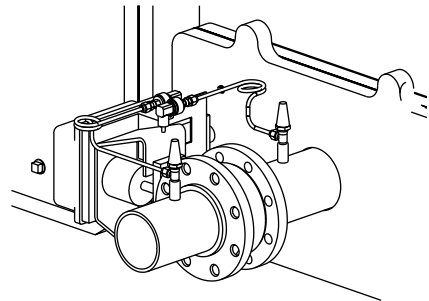

Table JC-1 – Steam Supply and Condensate Return Piping Responsibilities

Item	Material Provided By		Installed By	
	Trane	Other	Trane	Other
Energy Valve	X		X	
T-Type Strainer, Flanged connections, gate valve, drip leg w/dirt pocket, float and thermostatic trap, pressure gauge vent and valve, pressure reducing valve, pressure gauge, relief valve check valve, connecting piping.		X		X

Jobsite Connections

Steam Supply and Condensate Piping

Condensate Handling

Figure JC-1 illustrates a typical condensate system consisting of steam traps, condensate receivers and condensate pumps. Such systems provide the most economical method of returning condensate to a boiler. Properly sized float and thermostatic traps are required for proper operation. The use of bucket traps is not recommended.

Trane absorption machines use steam-throttling control. A maximum of three percent of the condensate may flash to a vented receiver at full load. This flashing decreases as the load decreases and is virtually nonexistent below 70 percent load. When the machine is operating at less than 70 percent load, the pressure in the generator tube bundle may be below atmospheric pressure. The temperature of the condensate leaving the machine under these conditions is less than 212°F (100°C), so flashing does not occur.

A subcooler may be installed ahead of the receiver to cool the condensate to a temperature below the saturation temperature at atmospheric pressure, thus eliminating flashing entirely. It is recommended that a cooling medium such as boiler feed water be used to keep this energy within the system. The pressure drop through the subcooler should be minimized.

Figure JC-1 indicates an equalizer line installed to avoid condensate backup in the machine. The swing check opens if a vacuum develops within the tube bundle under part-load operation.

This prevents development of a lower pressure in the concentrator than at the outlet of the trap.

Packaged Condensate Systems

Several manufacturers have available packaged condensate pump systems, designed for various condensate temperatures. A decision regarding the use of these systems with a Trane Absorption machine should be based on a thorough economic analysis of the particular installation. The following factors should be considered:

1. Condensate may flash in the receiver less than 20 percent of the total operating time in a typical installation. The amount of condensate which may flash varies from a maximum of three percent of full load to none at less than 70 percent load. A subcooler can be used to eliminate the small amount of flashing which may occur when the machine is operating under heavy load
2. The condensate system must prevent condensate from backing up into the machine at part load when the pressure in the generator tube bundle is below atmospheric pressure
3. The condensate system must not draw supply steam through the machine. This reduces the machine efficiency and may offset any potential energy savings, which might otherwise be realized by the use of the condensate return system. Also, reduced tube life would result due to erosion.

If the decision is made to use a packaged condensate pump system, follow the manufacturer recommendations regarding its application.

Jobsite Connections

Hot Water Piping

Hot Water Piping

The hot water system must be designed so as to avoid fluctuations in the pressure differences across the control valve. Trane absorption chillers for use with hot water may be used at entering hot water temperature of 270°F (132°C) or below. Piping for a typical hot water installation using a temperature of 270°F (132°C) or less is shown in Figure JC-2. In this arrangement a three-way energy valve is used to control capacity by varying the quantity of hot water flowing through the chiller while maintaining a constant supply and return flow rate. As shown in Figure JC-3, a two-way energy valve can also be used where the return and supply flow rates can vary. The generator design is rated to 150 psig (10.3 bar) with a 400 psig (27.6 bar) optional design available.

When the supply water temperature exceeds 270°F (132°C), a separate circulating pump is recommended in a run-around loop as shown in Figure JC-4. The hot water for the absorption machine should be taken from a header installed between the hot water supply and return mains. The flow of hot water through the machine is held constant, but the temperature of the circulating water is varied to meet load requirements by modulating the amount of high temperature supply water added to the loop. This is done by installing a two-way modulating valve at the loop outlet. The valve responds to the chilled water temperatures, but limits the water temperature entering the machine to a maximum of 270°F (132°C).

Hot Water Valves

Trane provides hot water temperature control valves with the machine for installation by the contractor at the job site. These valves are selected by The Trane company based on data provided by the contractor (*i.e. water flow to be used and the design pressure drop across the valve.)

It is desirable to use the smallest valve, with the highest pressure drop, appropriate to the design water flow and allowable pressure drop in the system. The smaller the valve, the better the control.

Figure JC-2– Hot Water Supply Temperature Piping – 270 F and Below with 3-Way Energy Valve

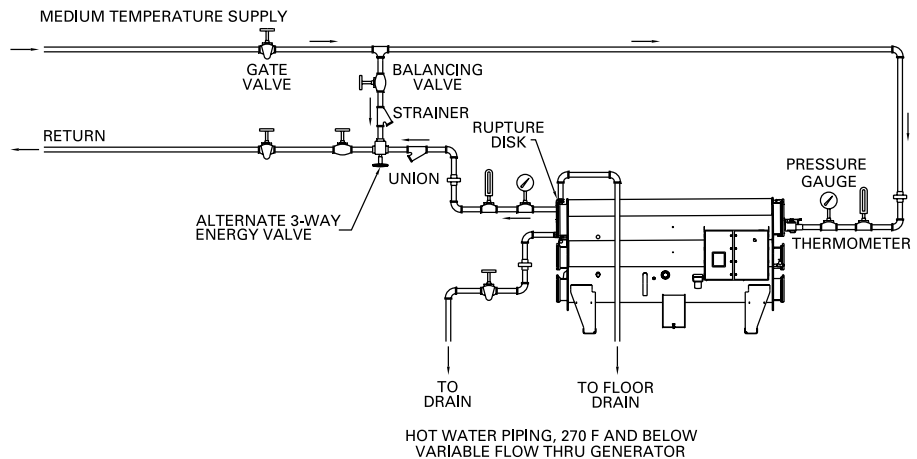
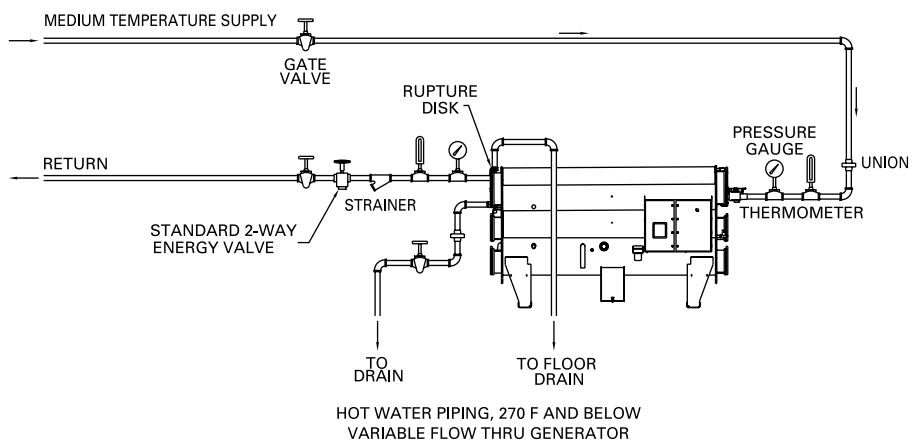

Figure JC-3 – Hot Water Supply Temperature Piping – 270 F and Below with 2-Way Energy Valve



Jobsite Connections

Hot Water Piping

Figure JC-4 – Hot Water Supply Temperature Piping Above 270 F

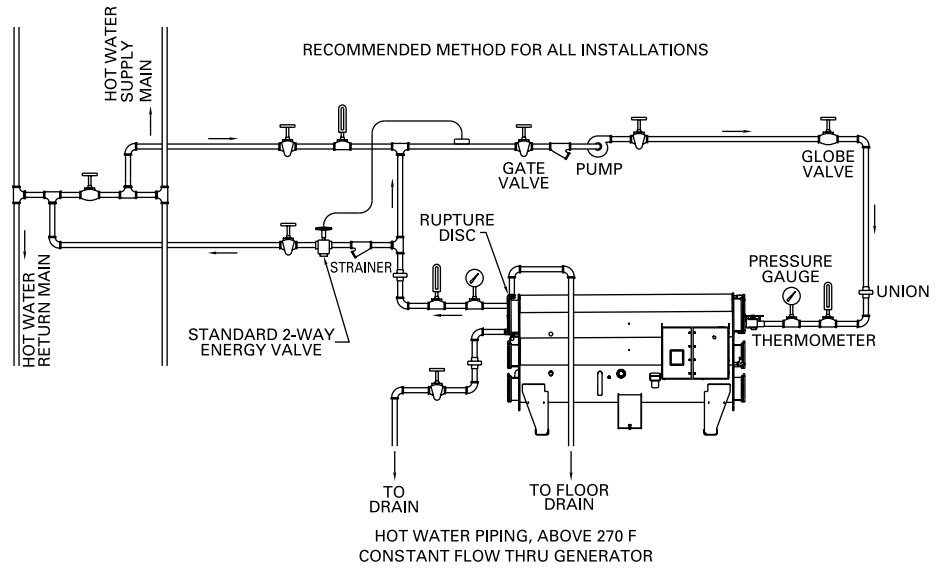

Table JC-2 – Hot Water Supply Piping Responsibilities

Item	Material Provided By		Installed By	
	Trane	Other	Trane	Other
Energy Valve (2-Way/3-Way)	X			X
Gate valve, balance valve, Y-type strainer w/valve, bypass circuit, check valve, thermometer, pressure gauge, vent shutoff valve, union or flanged connection circulating pump		X		X
Rupture Disk Assembly	X		X	
Rupture Disk Piping		X		X

Jobsite Connections

Cooling Water Piping

Cooling Water Piping

The cooling water piping design for absorption chillers differs from conventional reciprocating or centrifugal systems in that cooling water passes through the absorber section of the machine prior to entering the condenser.

The single stage absorption chiller is designed to start and operate with cooling water temperatures as low as 55°F (12.8°C). In typical applications, the machine is selected on the basis of the cooling water temperature that will be available at full-load and at the design outside conditions. In air conditioning applications utilizing a cooling tower, this is usually 85°F (29.4°C).

With a cooling tower sized at design conditions, the temperature of the cooling water supply to the unit will decrease with any decrease in cooling load or outside wet bulb temperature. The lower cooling water temperature would normally tend to increase the capacity potential of the unit. In the Trane design, the UCP2 adaptive controls will limit the energy input of the machine based on the entering cooling water temperature, thereby preventing overfiring of the machine.

In typical air conditioning applications, precise cooling water temperature control is not required. In process applications, however, where extremely close control of leaving chilled water is required, it is recommended that a tower valve be used to maintain cooling water temperature at a specified temperature. Constant cooling water temperature allows the unit control valve to more precisely control leaving chilled water temperature. Also, in applications where well water or other cooling water will be available at a temperature below 65°F (18.3°C), a control valve is recommended to maintain the temperature at 65°F (18.3°C) or above. Changes in condenser water temperature should not exceed 1 degree F per minute between the range of 75-95°F (23.9-35°C).

Figure JC-5 illustrates a typical air conditioning installation without a cooling tower control valve. Figure JC-6 illustrates typical cooling water piping in applications where a three-way valve may be required. Figure JC-7 illustrates typical cooling water piping utilizing well or river water.

Figure JC-5 – Cooling Water Piping with Cooling Tower

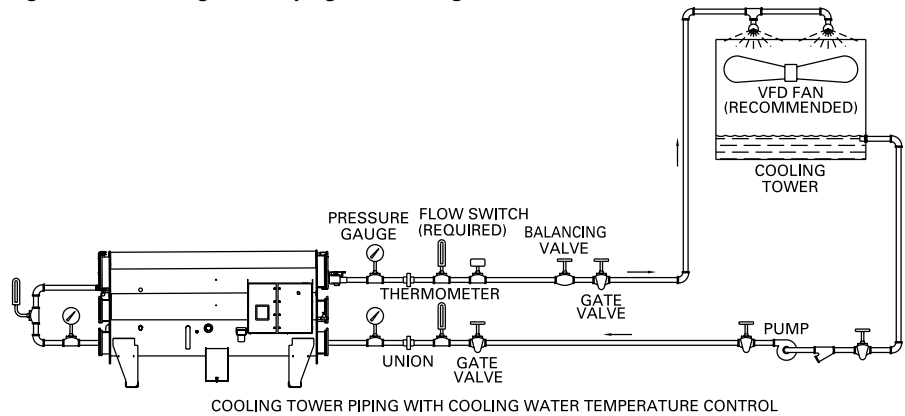

Figure JC-6 – Cooling Water Piping, Three-Way Mixing Valve

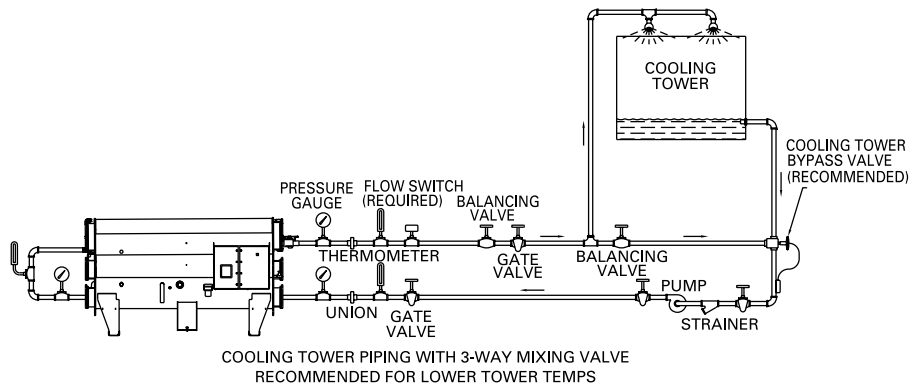

Figure JC-7 – Cooling Water Piping with Well or River Water

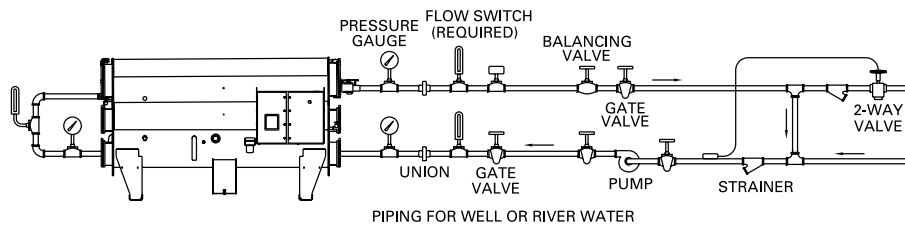

Table JC-3 – Condenser/Absorber Piping Responsibility

Item	Trane	Material Provided By		Installed By	
		Other	Trane	Trane	Other
Crossover Pipe	(factory installed option) X or	X	(factory installed option) X or		
Flow Switch	(optional) X or	X			X
Balancing valve, gate valve, thermometer (optional), pressure gauge vent and shutoff valve, Victaulic or flange connection, pipe stub, strainer, pump.		X			X

Mechanical Specifications

General

Unit is a complete single effect steam or hot water fired absorption chiller package built in an ISO 9001 environment. Chiller consists of generator/condenser section, evaporator/absorber section, controls, pumps, heat exchanger, and energy control valve. All units are of hermetic design, factory assembled and leak tested prior to shipment. Unit controls are factory mounted and wired including micro electronic control panel, sensors and purge system, energy valve can be factory mounted and wired as an option on steam fired units. Unit is painted prior to shipping with two coats of a water base air dry primer. Standard method of shipment is by truck from the USA.

Generator/Condenser-Evaporator/Absorber

The shell material is carbon steel. Standard generator tube material is cupro-nickel, evaporator is copper, absorber is cupro-nickel and condenser is copper. Tubes are mechanically rolled into the tube sheets and are replaceable from either end. Condenser, evaporator and absorber tube supports are fixed. Generator consists of fixed and floating tube supports to allow for even tube expansion.

Generator/Condenser-Evaporator/Absorber

Design working pressure for the water boxes is 150 psig (10.3 bar). All tube bundles are tested at 150 percent of design working pressure. All water boxes have gasketed removable covers for access. Water connections are provided with either victaulic or raised-face flanged connections.

Pumps

Each absorption machine is equipped with a single, hermetic pump motor assembly having three pump impellers on a common shaft. The pump bearings and the motor are cooled using distilled refrigerant water from the evaporator sump. There is a mechanical-magnetic strainer assembly in the pump motor cooling circuit. The pump motor is factory mounted and wired. The pump motor is removable without breaking the machine vacuum or removing solution from the machine. Also, pump bearing replacement is possible without removing solution or allowing air to enter the machine.

Purge System

Noncondensable gases are removed from the machine through a purge system termination in a cupronickel collection chamber located in the absorber section. This collection chamber is evacuated through an electrical motor driven vacuum pump. The purge system should be operated only as needed to remove any noncondensable gases that may be present. The machine is protected from re-entry of noncondensable gases by the discharge reed valve which provides a positive seal.

Generator

The shell is carbon steel. Tube sheets are steel and standard generator tubes are constructed of copper nickel. The generator has fixed and floating tube supports to allow for even tube expansion. For hot water as the energy source, the generator is ASME designed and stamped for 150 psi (10.3 bar). Generator/condenser includes rupture disk, which is sized to meet ANSI/ASHRAE B 15.

Optional Lithium Bromide Filter

The filter system consists of the filter assembly and the associated piping and filter isolation valves needed for operation and maintenance. The main filter body is stainless steel with a removable, cleanable, stainless steel internal 150-micron element. The filter isolation valves allow service of the filter assembly without disturbing operation of the rest of the machine.

Control Panel

The UCP2™ is a microprocessor-based chiller control system that provides complete stand-alone operation. It is a factory mounted package including a full compliment of controls to safely and efficiently operate the Absorption Liquid Chiller. The UCP2™ provides:

- Chilled water temperature control
- Concentration control

System Features and Functions

- User interface with a 40 character, 2 line display and a 16 key keypad, capable of displaying 7 languages and SI or English units
- Passwords for protection of unit setup and configuration
- Chilled water pump control
- Absorber/condenser pump control
- Automatic and manual control of solution and refrigerant pumps
- Economical solution flow control of the low temperature solution pump and absorber pump via an adjustable frequency drive
- Anti-crystallization through dilution control
- Automatic and manual purge system
- Chilled water reset
- Two-way valve assembly for hot water flow control or steam flow control
- Concentration control
- Steam adaptive flow control

Mechanical Specifications

Adaptive Limits

- Evaporator water temperature limit
- Low absorber/condenser limit
- Soft-loading control

System Protection

- Evaporator freeze protection
- Chilled water flow confirmation
- Cooling water flow confirmation
- Emergency stop/shutdown
- Under/over voltage detection

Monitor and Displays

- Chilled water temperature entering and leaving
- Absorber/condenser water temperature entering and leaving
- Solution concentrations
- Solution temperatures
- Total pump current
- Unit voltage
- Chiller run time and starts
- Purge operation and run time
- Alarm light
- Diagnostic messages
- Help screens
- Evaporator water flow (option)
- Cooling water flow (option)

Interfaces To UCP2™

- External machine manual reset alarm indication output
- External machine auto reset warning indication output
- External limit warning indication output
- Maximum capacity indication output
- External auto-stop/emergency shutdown
- Interface to Tracer Summit™
- External chilled water setpoint
- Tracer™ controlled relay
- Printer interface

Contractor Responsibilities

1. Install the unit on a level surface. Neoprene isolation pads supplied by the manufacturer shall be placed under the unit.
2. Connect unit control panel to all operating external safety and auxiliary control devices.
3. Insure that piping adjacent to the machine does not restrict removal of headers for inspection, cleaning and removing tubes.
4. Provide gauge cocks and optional thermometer wells for temperature and pressure readings at the inlet and outlet of the evaporator, at the inlet and outlet of the absorber, and at the outlet of the condenser.
5. Provide balancing valves in all external water circuits to allow balance and trim of the system.
6. Provide and install strainers ahead of all pumps and automatic modulating valves to insure proper pump and valve operation.
7. Insulate the chilled water headers and other portions of the unit, as pointed out in the manufacturer's installation literature to prevent condensation on cold surfaces and heat loss from hot surfaces to the equipment room. External unit pipes with surface temperatures sufficiently hot to constitute a danger to operating personnel shall also be insulated.
8. Provide and install a flow switch in the chilled water circuit and interlock it with the starting control circuit of the unit. Proof of flow is required prior to permitting unit operation. Provide and install a flow switch in

the tower water circuit, which shall be interlocked with the starting control circuit of the unit such that proof of flow is required to prevent machine damage

9. Provide necessary distilled or demineralized water for refrigerant charge, and trim charge.
10. Provide labor to charge the machine with lithium bromide solution and refrigerant water, and assist in machine starting and calibration under supervision of the manufacturer's representative.
11. Provide sufficient sized vacuum pump and personnel to evacuate the unit prior to charging (if required).
12. Install any control components provided by the manufacturer for installation external to the machine.
13. Furnish and install, external to the unit control panel, a separately fused disconnect switch, if not provided.
14. Install required power supply wiring to the control panel. Use copper wire only.

Insulation Required

Insulation is required on cold areas to prevent sweating. All insulation is installed in the field and provided/installed by others.

Insulation for cold insulation area should be ¾-inch (19 mm) Armaflex or equal should be applied to evaporator waterboxes, refrigerant storage tank, refrigerant pump and refrigerant piping.



Standard Conversion Table

To Convert From:	To:	Multiply By:	To Convert From:	To:	Multiply By:
Length			Energy and Power and Capacity		
Feet (ft)	meters (m)	.30481	British Thermal Units (BTUH)	Kilowatt (kW)	.000293
Inches (In)	millimeters (mm)	25.4	British Thermal Units (BTU)	KCalorie (Kcal)	.252
Area			Tons (refrig. effect)	Kilowatt (refrig. effect)	3.516
Square Feet (ft ²)	square meters (m ²)	.093	Tons (refrig. effect)	Kilocalories per hour (Kcal/hr)	3024
Square Inches (In ²)	square millimeters (mm ²)	645.2	Horsepower	Kilowatt (kW)	.7457
Volume			Pressure		
Cubic Feet (ft ³)	Cubic meters (m ³)	.0283	Feet of water (ftH ₂ O)	Pascals (PA)	2990
Cubic Inches (In ³)	Cubic mm (mm ³)	16387	Inches of water (inH ₂ O)	Pascals (PA)	249
Gallons (gal)	litres (l)	3.785	Pounds per square inch (PSI)	Pascals (PA)	6895
Gallons (gal)	cubic meters (m ³)	.003785	PSI	Bar or KG/CM ²	6.895 × 10 ⁻²
Flow			Weight		
Cubic feet/min (cfm)	cubic meters/second (m ³ /s)	.000472	Ounces (oz)	Kilograms (kg)	.02835
Cubic feet/min (cfm)	cubic meters/hr (m ³ /hr)	1.69884	Pounds (lbs)	Kilograms (kg)	.4536
Gallons/minute (GPM)	cubic meters/hr (m ³ /hr)	.2271	Fouling factors for heat exchangers		
Gallons/minute (GPM)	litres/second (l/s)	.06308	.00075 ft ² °F hr/BTU	= .132 m ² ° K/kW	
Velocity			.00025 ft ² °F hr/BTU	= .044 m ² ° K/kW	
Feet per minute (ft/m)	meters per second (m/s)	.00508			
Feet per second (ft/s)	meters per second (m/s)	.3048			

Temperature — Centigrade (°C) Versus Fahrenheit (°F)

Note: The center columns of numbers, referred to as BASE TEMP., is the temperature in either degrees Fahrenheit (°F) or Centigrade (°C), whichever is desired to convert into the other. If degrees Centigrade is given, read degrees Fahrenheit to the right. If degrees Fahrenheit is given, read degrees Centigrade to the left.

Temperature			Temperature			Temperature			Temperature			Temperature		
°C	C or F	°F	°C	C or F	°F	°C	C or F	°F	°C	C or F	°F	°C	C or F	°F
-40.0	-40	-40.0	-15.0	+5	+41.0	+10.0	+50	+122.0	+35.0	+95	+203.0	+60.0	+140	+284.0
-39.4	-39	-38.2	-14.4	+6	+42.8	+10.6	+51	+123.8	+35.6	+96	+204.8	+60.6	+141	+285.8
-38.9	-38	-36.4	-13.9	+7	+44.6	+11.1	+52	+125.6	+36.1	+97	+206.6	+61.1	+142	+287.6
-38.3	-37	-34.6	-13.3	+8	+46.4	+11.7	+53	+127.4	+36.7	+98	+208.4	+61.7	+143	+289.4
-37.8	-36	-32.8	-12.8	+9	+48.2	+12.2	+54	+129.2	+37.2	+99	+210.2	+62.2	+144	+291.2
-37.2	-35	-31.0	-12.2	+10	+50.0	+12.8	+55	+131.0	+37.8	+100	+212.0	+62.8	+145	+293.0
-36.7	-34	-29.2	-11.7	+11	+51.8	+13.3	+56	+132.8	+38.3	+101	+213.8	+63.3	+146	+294.8
-36.1	-33	-27.4	-11.1	+12	+53.6	+13.9	+57	+134.6	+38.9	+102	+215.6	+63.9	+147	+296.6
-35.6	-32	-25.6	-10.6	+13	+55.4	+14.4	+58	+136.4	+39.4	+103	+217.4	+64.4	+148	+298.4
-35.0	-31	-23.8	-10.0	+14	+57.2	+15.0	+59	+138.2	+40.0	+104	+219.2	+65.0	+149	+300.2
-34.4	-30	-22.0	-9.4	+15	+59.0	+15.6	+60	+140.0	+40.6	+105	+221.0	+65.6	+150	+302.0
-33.9	-29	-20.2	-8.9	+16	+60.8	+16.1	+61	+141.8	+41.1	+106	+222.8	+66.1	+151	+303.8
-33.3	-28	-18.4	-8.3	+17	+62.6	+16.7	+62	+143.6	+41.7	+107	+224.6	+66.7	+152	+305.6
-32.8	-27	-16.6	-7.8	+18	+64.4	+17.2	+63	+145.4	+42.2	+108	+226.4	+67.2	+153	+307.4
-32.2	-26	-14.8	-7.2	+19	+66.2	+17.8	+64	+147.2	+42.8	+109	+228.2	+67.8	+154	+309.2
-31.7	-25	-13.0	-6.7	+20	+68.0	+18.3	+65	+149.0	+43.3	+110	+230.0	+68.3	+155	+311.0
-31.1	-24	-11.2	-6.1	+21	+69.8	+18.9	+66	+150.8	+43.9	+111	+231.8	+68.9	+156	+312.8
-30.6	-23	-9.4	-5.5	+22	+71.6	+19.4	+67	+152.6	+44.4	+112	+233.6	+69.4	+157	+314.6
-30.0	-22	-7.6	-5.0	+23	+73.4	+20.0	+68	+154.4	+45.0	+113	+235.4	+70.0	+158	+316.4
-29.4	-21	-5.8	-4.4	+24	+75.2	+20.6	+69	+156.2	+45.6	+114	+237.2	+70.6	+159	+318.2
-28.9	-20	-4.0	-3.9	+25	+77.0	+21.1	+70	+158.0	+46.1	+115	+239.0	+71.1	+160	+320.0
-28.3	-19	-2.2	-3.3	+26	+78.8	+21.7	+71	+159.8	+46.7	+116	+240.8	+71.7	+161	+321.8
-27.8	-18	-0.4	-2.8	+27	+80.6	+22.2	+72	+161.6	+47.2	+117	+242.6	+72.2	+162	+323.6
-27.2	-17	+1.4	-2.2	+28	+82.4	+22.8	+73	+163.4	+47.8	+118	+244.4	+72.8	+163	+325.4
-26.7	-16	+3.2	-1.7	+29	+84.2	+23.3	+74	+165.2	+48.3	+119	+246.2	+73.3	+164	+327.2
-26.1	-15	+5.0	-1.1	+30	+86.0	+23.9	+75	+167.0	+48.9	+120	+248.0	+73.9	+165	+329.0
-25.6	-14	+6.8	-0.6	+31	+87.8	+24.4	+76	+168.8	+49.4	+121	+249.8	+74.4	+166	+330.8
-25.0	-13	+8.6	.0	+32	+89.6	+25.0	+77	+170.6	+50.0	+122	+251.6	+75.0	+167	+332.6
-24.4	-12	+10.4	+0.6	+33	+91.4	+25.6	+78	+172.4	+50.6	+123	+253.4	+75.6	+168	+334.4
-23.9	-11	+12.2	+1.1	+34	+93.2	+26.1	+79	+174.2	+51.1	+124	+255.2	+76.1	+169	+336.2
-23.3	-10	+14.0	+1.7	+35	+95.0	+26.7	+80	+176.0	+51.7	+125	+257.0	+76.7	+170	+338.0
-22.8	-9	+15.8	+2.2	+36	+96.8	+27.2	+81	+177.8	+52.2	+126	+258.8	+77.2	+171	+339.8
-22.2	-8	+17.6	+2.8	+37	+98.6	+27.8	+82	+179.6	+52.8	+127	+260.6	+77.8	+172	+341.6
-21.7	-7	+19.4	+3.3	+38	+100.4	+28.3	+83	+181.4	+53.3	+128	+262.4	+78.3	+173	+343.4
-21.1	-6	+21.2	+3.9	+39	+102.2	+28.9	+84	+183.2	+53.9	+129	+264.2	+78.9	+174	+345.2
-20.6	-5	+23.0	+4.4	+40	+104.0	+29.4	+85	+185.0	+54.4	+130	+266.0	+79.4	+175	+347.0
-20.0	-4	+24.8	+5.0	+41	+105.8	+30.0	+86	+186.8	+55.0	+131	+267.8	+80.0	+176	+348.8
-19.4	-3	+26.6	+5.5	+42	+107.6	+30.6	+87	+188.6	+55.6	+132	+269.6	+80.6	+177	+350.6
-18.9	-2	+28.4	+6.1	+43	+109.4	+31.1	+88	+190.4	+56.1	+133	+271.4	+81.1	+178	+352.4
-18.3	-1	+30.2	+6.7	+44	+111.2	+31.7	+89	+192.2	+56.7	+134	+273.2	+81.7	+179	+354.2
-17.8	0	+32.0	+7.2	+45	+113.0	+32.2	+90	+194.0	+57.2	+135	+275.0	+82.2	+180	+356.0
-17.2	+1	+33.8	+7.8	+46	+114.8	+32.8	+91	+195.8	+57.8	+136	+276.8	+82.8	+181	+357.8
-16.7	+2	+35.6	+8.3	+47	+116.6	+33.3	+92	+197.6	+58.3	+137	+278.6	+83.3	+182	+359.6
-16.1	+3	+37.4	+8.9	+48	+118.4	+33.9	+93	+199.4	+58.9	+138	+280.4	+83.9	+183	+361.4
-15.6	+4	+39.2	+9.4	+49	+120.2	+34.4	+94	+201.2	+59.4	+139	+282.2	+84.4	+184	+363.2

FOR INTERPOLATION IN THE ABOVE TABLE USE:

BASE TEMPERATURE (°F or °C):	1	2	3	4	5	6	7	8	9	10
DEGREES CENTIGRADE:	0.56	1.11	1.67	2.22	2.78	3.33	3.89	4.44	5.00	5.56
DEGREES FAHRENHEIT:	1.8	3.6	5.4	7.2	9.0	10.8	12.6	14.4	16.2	18.0

ISO 9001
Quality System
Certified



La Crosse
Business Unit



The Trane Company
An American Standard Company
www.trane.com

For more information contact
your local sales office or
e-mail us at comfort@trane.com

Literature Order Number ABS-PRC005-EN

File Number PL-RF-ABS-000-PRC005-EN-0301

Supersedes New

Stocking Location La Crosse

Since The Trane Company has a policy of continuous product and product data improvement, it reserves the right to change design and specifications without notice.