

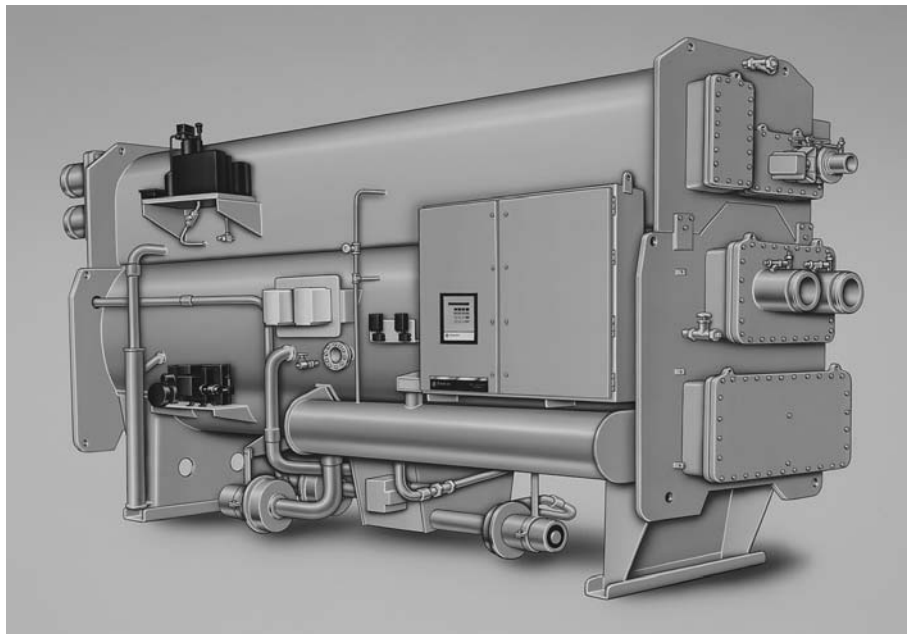

Trane Horizon[®] Absorption Series

**Single-Stage Hot Water or
Steam-Fired Absorption Water Chillers
500-1350 Tons**

Built for Industrial and Commercial Applications



Introduction



Hybrid Chiller Plant

A chiller plant design that allows the operator to choose between multiple energy sources is referred to as a hybrid design. Hybrid chiller plants are receiving increasing attention as valuable options for facility owners. There are various types of hybrid plant designs. They encompass different combinations of electric chillers and other chiller types, including gas or steam absorption chillers. The advantages of having a choice of energy sources will become even more viable as we move further into the new millennium.

Today we hear about utility deregulation. For the first time, building owners can negotiate power supply and natural gas contracts with their traditional supplier, as well as with new suppliers in the market. The fuel-switching flexibility of the hybrid plant puts the owner in a much stronger negotiating position. Similarly, many electric utilities offer attractive off-peak or dual fuel electric rates for applications which are not operating during peak electric system demand, most commonly in the summer months. This represents an opportunity for building owners who can switch to a gas or steam system.

Contents

Trane Horizon® Absorption Series

Trane has led in absorption chiller design and manufacturing for four consecutive decades. In fact, Trane is the only North American chiller manufacturer to commercialize double-effect absorption, over 25 years ago. With over 10,000 absorption chillers manufactured and shipped, Trane serves the commercial, industrial and process worldwide markets. Microelectronic controls, adaptive frequency drives and smart purge systems have modernized the technology, making it more capable, more reliable and, in many applications, more economical.

Performance

- Produces colder chilled water to 40°F [4.4°C].
- Starts with low 55°F [12.8°C] tower-water temperatures.
- Operates reliably with low 65°F [18.3°C] tower-water temperatures.

Easier Installation

- Rigging eyes built-in as standard.
- Shell disassembly option.
- Crossover pipe and steam valve available as an option.

Reliability

- Adaptive microprocessor controls.
- 50,000 hours life-extended pumps.
- Constructed of corrosion-resistant alloy materials.

Design Diversity

- Marine water boxes on cooling-water connections available as an option.
- Custom design options available.

Introduction

2

Features and Benefits

4

Component Identification, Typical Single-Stage Steam Illustration, Refrigerant Cycle Overview

Application Considerations

8

Operating Limits, Sound, Water Flow/Treatment, Combination Systems, Multiple Machines

Selection Procedure

9

Computer Selection Procedure, Tube Fouling, Product Coding Description

Performance Data

12

Capacity/COP/Steam Rate/Flow Rate, Pressure Drop Tables, Capacity vs. Chilled Water Supply Temperature, Energy Input vs. Capacity, Pressure Drop vs. Flow Rate

Electrical Data

17

Controls Data

20

Dimensions and Weights

24

Physical Dimensions, Weights, Connection Sizes, Refrigerant Charging, Separated Machine Sections, Foundation Support, Rigging/Service Clearances, Chiller Isolation, Insulation Lengths

Jobsite Connections

34

Typical Piping

Mechanical Specifications

40

Standard/Optional/Design Special Features

42

Standard Conversion Table

43



Features and Benefits

General

Trane Horizon® Absorption Series, Single-Stage Hot Water- or Steam-Fired Absorption Water Chillers, 500-1350 Tons

Technology You Can Trust

In the early 1990's, with the assistance of the Gas Research Institute, Trane began developing an innovative series of absorption chillers. In 1995, Horizon chillers began shipping from the Trane manufacturing facility in La Crosse, Wisconsin. The Horizon chiller is so advanced, it redefined industry standards for absorption system integrity. Horizon chiller performance, efficiency and reliability far exceed that of past and present absorption chillers.

Dynamic By Design

Because uninterrupted chiller service is critical to your operation, Horizon chillers are designed to make chilled water reliably, even in the harshest industrial application. Water-tower systems and load requirements can challenge the long-term operation of many standard-grade chillers. The industrial-grade construction of the Horizon chiller accounts for varying load and water-temperature changes, as well as dirty tower water. They are built with corrosive-resistant alloy metals, and precision welded in an ISO 9001 quality-certified facility. Only extended-life pumps, valves and water boxes are manufactured into their design. For further dynamics, Horizon UCP2 adaptive microprocessor controls react precisely to system diversification. Quality construction, long-life components and adaptive controls are what make the Horizon dynamic by design.

Operates With Energy-Saving, Low-Pressure Steam or Hot Water

The Horizon family includes a single-stage, hot water- or steam-fired chiller line. Able to produce chilled water in the range of 40 to 60°F [4.4 to 15.6°C], these machines use 12 psig [0.83 bar] low-grade steam or 270°F [132°C] hot water.

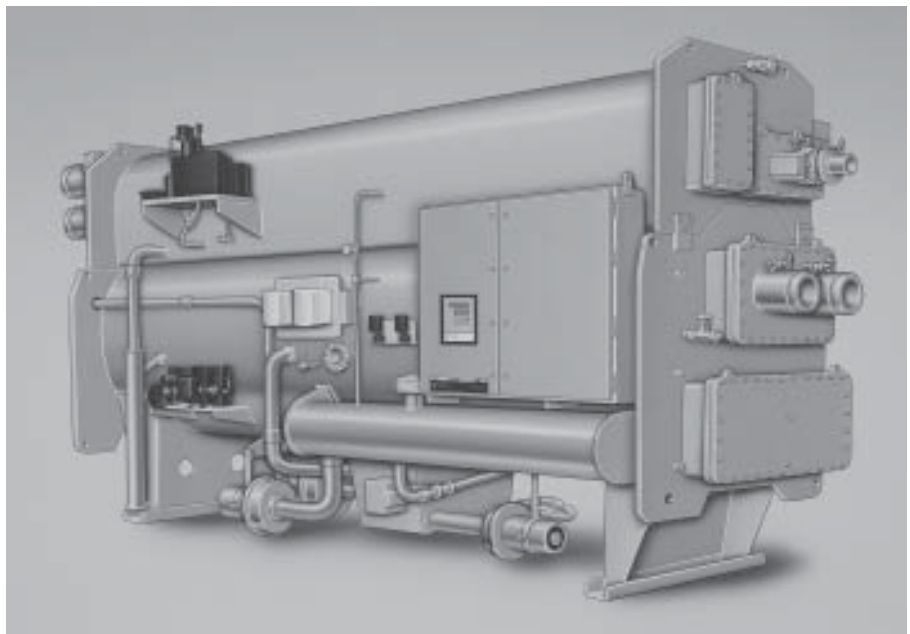
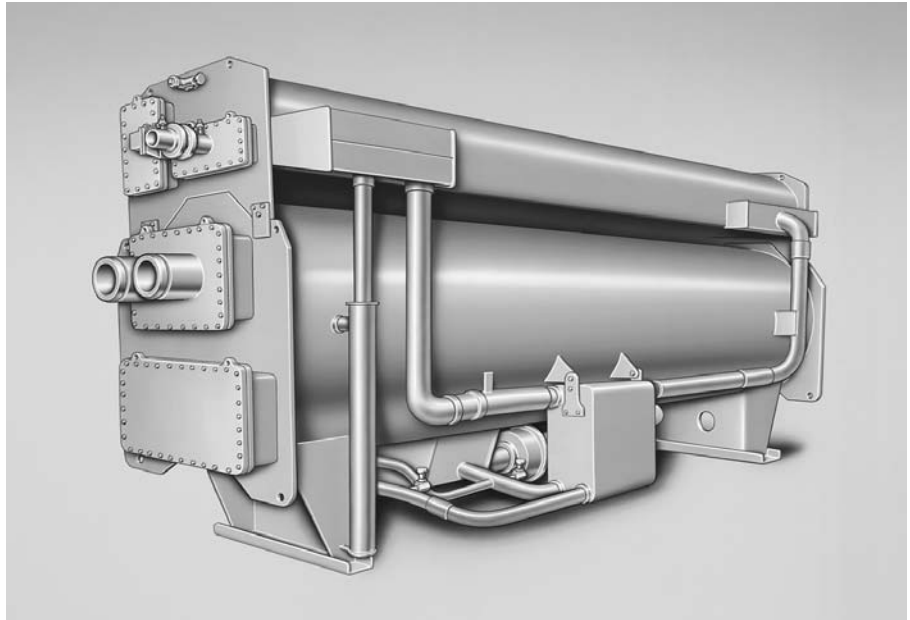

Making chilled water from these comparatively low-temperature inputs is particularly important for energy conserving applications, such as waste-heat recovery, co-generation equipment and solar-energy-powered cooling.

Using refrigerant water helps eliminate refrigerant management or availability concerns. Additionally, absorption technology reduces the use of electric energy.

Features and Benefits

General

Sophisticated Reliability

Horizon controls meet specifications for stand alone or hybrid chiller control. UCP2 adaptive controls are critical to reliable operation. Trane controls are compatible with Integrated Comfort™ Systems (ICS), and are easily integrated into the Tracer® family of flexible chiller-plant system controllers with a single twisted-pair communications cable.

Ideal for Process and Commercial Applications

With Horizon chillers, the application possibilities for the absorption machine are expanded. Capabilities such as lower tower flow, variable evaporator flow, lower chilled-water temperatures and advanced control capabilities make the single-stage Horizon absorption chiller ideal for both process and comfort applications.

When Long-lived Reliability Is Important

Trane has been a long-time proponent of the use of high-quality materials in absorption chiller designs. The lithium bromide temperatures and water refrigerant, typical of all absorbers, can more quickly corrode lower-grade metals in the presence of air. Trane recommends and uses industrial-grade materials to provide long-lived, reliable cooling.

A Global Network of Absorption Expertise

When you specify a Trane Horizon chiller, you're getting the knowledge, expertise and assistance of a pool of experts that have decades of absorption expertise. Making The Trane Company part of your management team gives you access to refrigeration, air conditioning and facility control-system applications specialists, and a unique breadth of innovative solutions to satisfy your facilities needs for today and tomorrow.

Standard Specification For Single-Stage Horizon Chillers

- C.O.P. 0.70
- Victaulic™ water connections
- Fully-automatic purge system
- Industrial-grade tubes
 - Generator .028" wall, 90/10 Cupro-nickel
 - Evaporator .025" wall copper (enhanced)
 - Absorber 500-800 tonnages .022" wall 95/5 Cupro-nickel 975-1350 tonnages .028" wall copper
 - Condenser .028" wall copper
- Advanced cycle-management system with Adaptive Frequency™ drive solution control
- 150 psig [10.3 bar] evaporator, absorber and condenser sections
- Industrial-grade energy valve
- Rigging eyes for easy installation
- Advanced microprocessor control system with adaptive control functions
- 2-line, 40-character clear-language interface to unit functions and diagnostic information
- Fixed and floating generator tube supports prevent thermal stress
- Efficient stainless steel brazed plate solution heat exchanger
- Long-life solution pumps
- Molybdate inhibitor system
- Factory-installed and-commissioned controls
- Individually replaceable tubes
- Removable absorber and evaporator spray trees

Optional Specification For Single-Stage Horizon Chillers

- Removable absorber and evaporator spray trees 150 psig [10.3 bar] raised face flanges for the evaporator, condenser, and absorber water connections
- Disassembled unit — eases disassembly and reassembly of major components at the job site
- Lithium bromide filter
- Condenser and absorber marine style water boxes
- Factory installed cooling-water crossover pipe absorber to condenser
- Factory mounted energy valve
- Choice of tube materials and other chiller options
- Stainless steel evaporator pan

Absorption Cooling —

A Sound Decision

Life-cycle costing has become a primary concern for chiller buyers who have long-term investment opportunity in mind. Changes in the distribution and pricing of electricity have made the absorption water chiller a popular choice when alternative energy use makes sense. Ask your local Trane representative for a comprehensive analysis of your facility, and the energy-saving opportunities Trane offers for the design of Heating, Ventilating and Air Conditioning systems and controls.

Features and Benefits

Component Identification

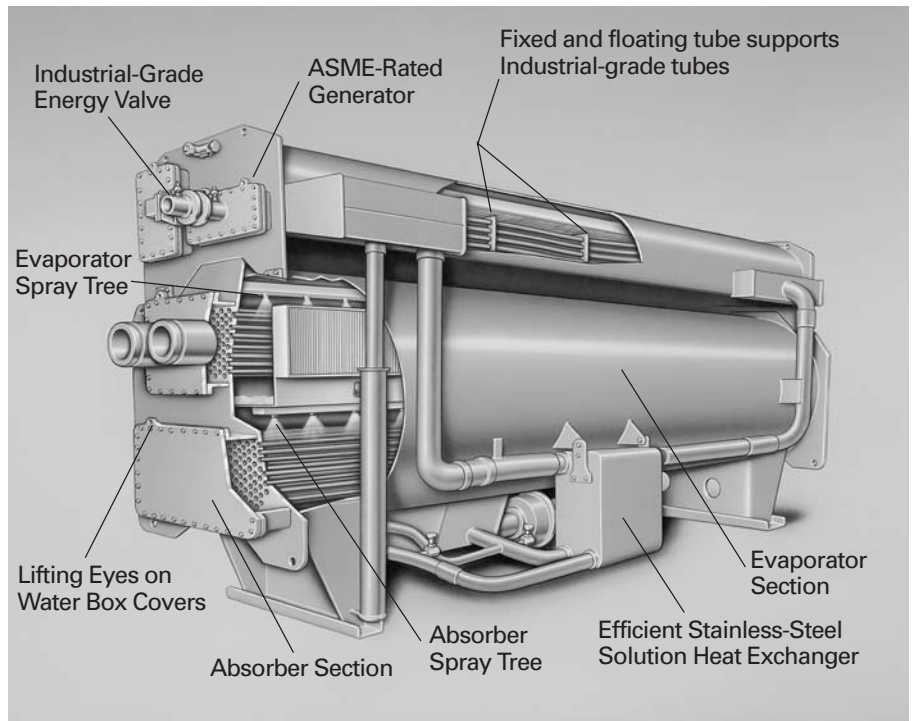
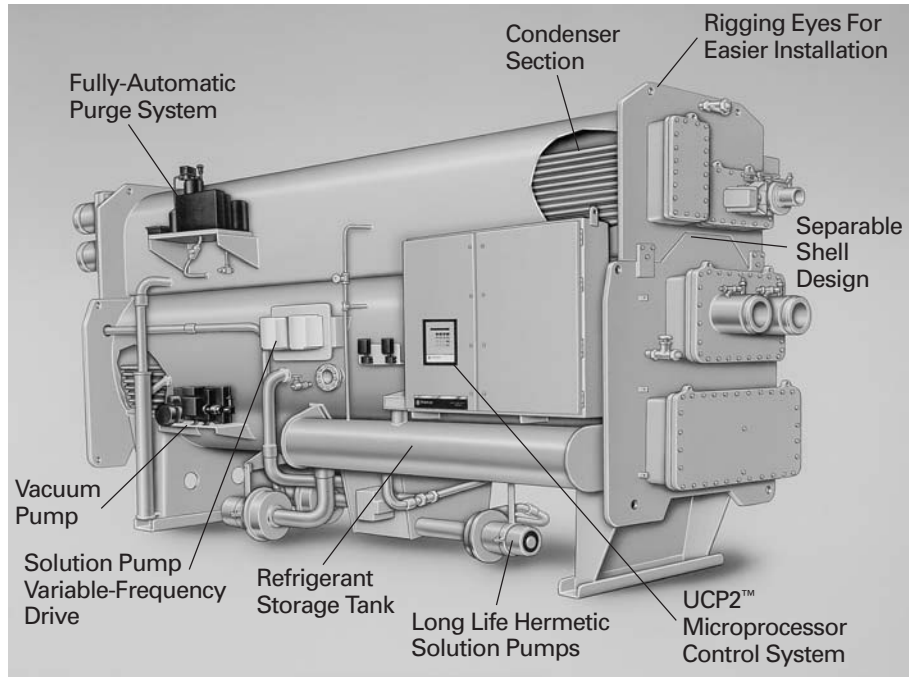

Features and Benefits

Refrigeration Cycle

Horizon Single-Stage Absorption Refrigeration Cycle

Refrigeration Cycle

This is an example of typical machine operation at a standard rating point condition (i.e., 85°F [29.4°C] tower, 44°F [6.7°C] leaving chilled water) at full load. Dilute solution has a relatively high refrigerant content and low lithium bromide content. An intermediate solution is a mixture of dilute and concentrated solutions. A concentrated solution is one with a relatively low refrigerant content and high lithium bromide content.

Generator (1)

Dilute solution is pumped into the generator, where it is boiled by the steam or hot water in the tube bundle, creating refrigerant vapor. The refrigerant vapor flows to the condenser (2). The now-concentrated solution flows by gravity, through the solution heat exchanger to the absorber spray system, where it is mixed with dilute solution from the absorber and sprayed on the absorber tube bundle.

Condenser (2)

Refrigerant vapor, produced by the generator, enters the condenser and changes to a liquid through condensation. The heat of condensation is rejected to the cooling water inside the tube bundle.

Evaporator (3)

The liquid refrigerant leaves the condenser through a J tube, where the pressure/temperature is reduced through expansion for delivery to the evaporator at 41°F [5°C]. System water runs through the tube bundle where its heat is transferred to the refrigerant, causing the refrigerant to vaporize/boil. The refrigerant vapor flows to the slightly lower pressure in the absorber.

Absorber (4)

Refrigerant vapor is absorbed by the lithium bromide solution. The now-dilute solution is pumped through the solution heat exchanger and on to the generator. The heat of vapor absorption is rejected via the cooling water inside the tube bundle.

Figure FB-1. Single-stage absorption refrigeration cycle

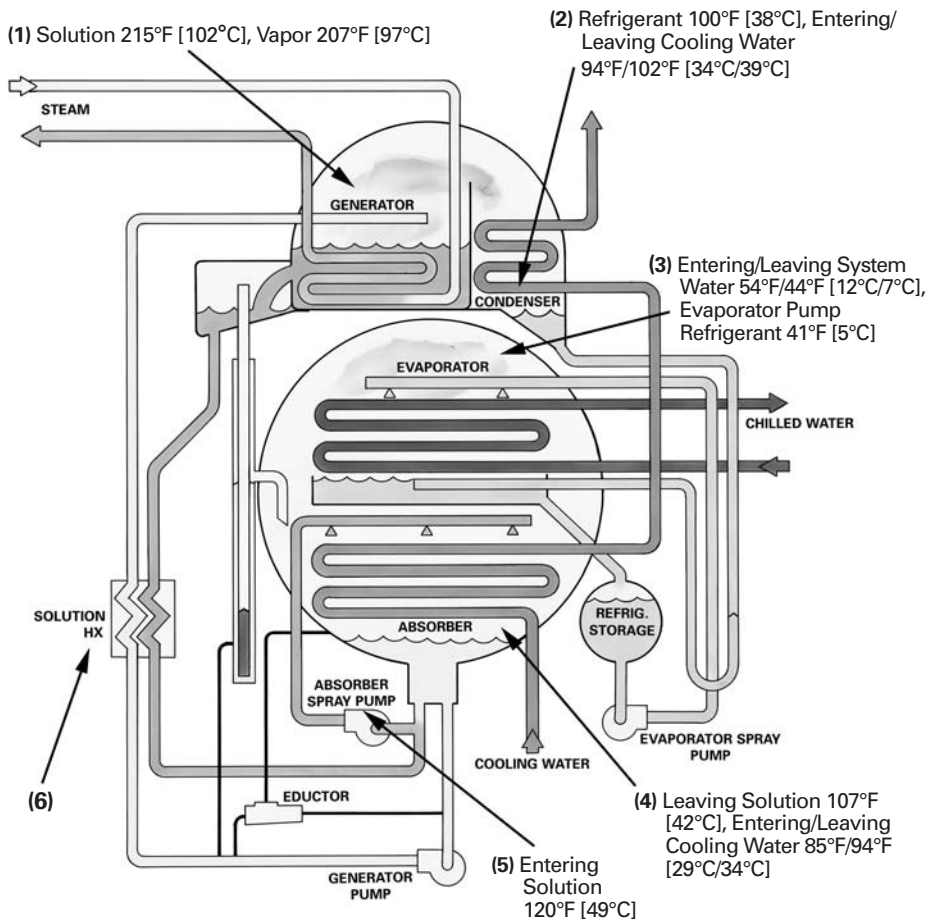

Absorption Process (5)

Solution (concentrated) enters the spray system from the generator and enters the spray system, wetting the tubes and providing a liquid surface for the refrigerant vapor (from the evaporator) to absorb into the lithium bromide solution. The solution temperature/concentration sprayed in the absorber controls the absorber pressure, thereby controlling the evaporator refrigerant temperature.

Solution Heat Exchanger (6)

Solution flows through the heat exchanger to be preheated, reducing the heat energy required to induce boiling within the generator, and to decrease the temperature of the solution being returned to the absorber, thus decreasing the load on the cooling tower.



Application Considerations

General

General

The Horizon single-stage steam-fired or hot water absorption chiller is designed to provide 40°F to 60°F [4.4°C to 15.6°C] chilled water, for comfort or process cooling applications, within all three market segments – commercial, industrial and institutional. They are most-often used where an economic analysis of fuel costs versus electrical rates indicates an operating cost advantage.

In many process applications, they can be utilized to convert excess heat energy to provide chilled water for process or comfort applications.

Operating Limits

Trane single-stage absorption chillers operate with nominal 12 psig [0.83 bar] steam or nominal 270°F [132°C] hot water. In all applications, superheat should be limited so steam temperature does not exceed 340°F [171°C].

Waterflows that are within the limits indicated on the appropriate selection table will ensure tube water velocities not exceeding 10 feet per second [3.05 m/sec] in copper tubes and 11 feet per second [3.35 m/sec] in cupronickel tubes. Changes in condenser water temperature should not exceed 1°F per minute in the range from 75°F to 95°F [23.9°C to 35°C].

Sound and Vibration

Absorption units are well-suited for areas where low sound levels are required. The Trane Horizon single-stage steam absorption chiller will operate under normal load conditions at less than 85 dBA sound pressure level. During operation there is no vibration of any components that could be damaging to the chiller or that could transmit objectionable sound or vibration to the building.

Chiller Installation

The following should be considered when installing an absorption chiller:

- Rigging and service clearances
- Foundation support
- Chiller isolation for sound/vibration reduction
- Condensate handling
- Steam supply control
- Condenser-water temperature control
- Chilled-water flow control
- Chilled- and condenser-water flow limit
- Generator hot-water application

Cooling-Tower Water Flow

The ARI standard gpm/ton for single-stage absorption chillers is 3.6, however, lower flow through the condenser and absorber section will present an opportunity for a smaller tower, smaller piping, and smaller condenser pump. For more information on lower flows in the cooling tower water circuit, refer to the appropriate Trane engineering bulletin, available from your local Trane representative.

Water Treatment

The use of untreated or improperly treated water may result in scaling, erosion, and corrosion, algae or slime. It is recommended that the services of a qualified water-treatment specialist be used to determine what treatment, if any, is advisable. The Trane Company assumes no responsibility for the results of untreated or improperly treated water.

Combination Systems

Peak energy savings can be achieved when using a combination of electric chillers and absorption chillers for air conditioning loads. The absorption chiller is used to shave seasonal, billable peak-power demands during summer operation, and the electric chiller is run below the allowed demand limit, reducing costly demand charges. Trane offers both electric chillers and absorption chillers with the unit control panel (UCP2) as standard. Although the

chillers have different features and modes of operation, the chiller control panel looks and acts the same when used with any chiller model. Each control panel is programmed to monitor the particular chiller for which it was designed, however, maintenance and service personnel only need to become familiar with one control panel. Combined with a Trane Tracer® system, a chiller plant has almost unlimited operational flexibility, and all equipment is supplied from a single source.

Multiple Machine Installations

The Trane absorption machine can be applied to series or parallel chilled-water flow, depending upon the design requirement. The arrangement that is best for an individual system should be based on an analysis of system water and temperature rise requirements, system and machine pressure-drop characteristics, and installation cost.

Parallel flow allows minimum chilled-water pressure drop through the machines. However, with one machine “off,” it is not usually possible to maintain the design chilled-water temperature unless one machine is isolated with shut off valves and the chilled-water flow decreased.

Series flow permits design chilled-water temperature at light loads with one machine “off.” However, at all operating conditions, the chilled-water pressure drop through the machine is high.

Accurate chilled-water temperatures can be maintained on individual machines between 100 percent and 10 percent of nominal chiller load, which allows for a wide range of control options. Each chiller has a stand-alone control system to manage the desired water temperature, and also the ability to receive remote commands to support various system demands from a control center. This versatility of control makes the management of more than one machine relatively easy.

Selection Procedure

Selection Procedure

Absorption refrigeration machines are usually selected to provide the required refrigeration capacity with the smallest practical machine of sufficient size. Machine size is based on chilled-water flow rates and temperatures specified for the air side of the system.

Total air-conditioning system first cost can be minimized by a careful analysis of system operating parameters. The effect of flow rates and temperatures, on both the building air side and the refrigeration machine selections, should be investigated to determine which system represents the best investment for the owner.

The information on the following pages provides performance data, at ARI standard conditions, for capacity in tons, efficiency, flow rates and water pressure drops. All capacities are in accordance with the expected ARI 560 Standard revision, and are based on fouling factors of .0001 for the evaporator waterside tubing and .00025 for the absorber and condenser tubing.

Standard Fouling

Unit performance at non-standard fouling factors may vary from standard performance. Fouling factors estimate the heat transfer penalty that coincides with the effect of typical fouling in evaporator and absorber/condenser (cooling) water circuits. All selections should use the standard fouling factor to more accurately estimate the chiller performance in an equipment room and to comply with ARI 560.

ARI Standard Fouling Factors

Evaporator	Condenser/Absorber
English Units – hr-ft²-F/Btu	
0.0001	0.00025
SI Units – m²-K/kW	
0.018	0.044

Additional Fouling

Any selection that uses a fouling factor greater than 0.0001 for the evaporator tubes, and 0.00025 for the condenser/absorber tubes, is a more conservative estimate that should only be used if there is an abnormal amount of fouling contaminants in the water systems. The ARI 560 Standard defines “additional fouling” as “Conditions such as water hardness, organic material, suspended solids and/or water velocity may necessitate the use of a greater field fouling allowance than that provided in the Standard Rating of equipment.” The Trane single-stage Horizon Selection program should be used to determine the effect of nonstandard fouling factors. The following guidelines can be used for estimation prior to the selection:

ARI Standard Fouling Factors For Additional Fouling

Evaporator	Condenser/Absorber
English Units – hr-ft²-F/Btu	
0.0002	0.00026 – 0.00075
SI Units – m²-K/kW	
0.035	0.046

Part Load Performance

The Horizon® single-stage absorption chiller exhibits excellent part-load performance characteristics. Air conditioning system loads are usually significantly less than full-load design conditions. Therefore, the absorption chiller operates at full load a small percentage of the time. Part-load absorption chiller operation is normally associated with reduced tower-water temperatures. At part-load operation, the heat rejected to the cooling tower is less than at full-load operation. Also, part-load operation is typically associated with reduced outside wet-bulb temperatures, resulting in improved cooling tower performance. The net result of less heat rejection and lower wet-bulb temperature is cooler tower water entering the chiller and improved unit performance.

Final Selection

A final selection must be done by the local Trane sales engineer using the Trane Horizon® Single-Stage Absorption Selection Program. For applications higher than 1600 feet [500 meters] above sea level, final selection requires review by Absorption Product Marketing. Prior to accessing the computer selection program, the following data inputs should be tabulated:

- Temperature or pressure of the hot water or steam
- Two of the following three values must be provided¹:
 - Evaporator Delta-T
 - Evaporator Flow
 - Cooling Capacity
- Leaving-Evaporator Water Temperature
- Entering-Absorber Water Temperature
- Cooling Water Flow
- Chilled water and tower water fouling factors

Other options that may also be selected are:

- Type and thickness of tube material
- Type of solution flowing through the evaporator and tower loop².

¹ Any limitations or restrictions should also be given (i.e., pressure drop, gpm etc.).

² Absorption chillers can be selected with a wide variety of media other than water (evaporator and absorber/condenser, or both). For media other than water, contact the local Trane sales office for chiller selections and information.



Selection Procedure

Product Coding Description

Selection

Product Coding Description

The coding block precisely identifies all characteristics of any Horizon® Single-Stage Steam-Fired or Hot Water Absorption Chiller.

Table S-1. Product coding description

MODL	Absorption Unit Model
ABSD	Single Stage Absorption
NTON	Unit Nominal Tonnage
500	500 Nominal Tons
600	600 Nominal Tons
700	700 Nominal Tons
800	800 Nominal Tons
975	975 Nominal Tons
1100	1100 Nominal Tons
1225	1225 Nominal Tons
1350	1350 Nominal Tons
VOLT	Unit Voltage
190	190 Volt - 50 HZ
200	200 Volt - 60 HZ
220	220 Volt - 50 HZ
230	230 Volt - 60 HZ
380	380 Volt - 50 HZ
415	415 Volt - 50 HZ
460	460 Volt - 60 HZ
575	575 Volt - 60 HZ
ENSR	Unit Energy Source
STM	Steam Energy Source
HOTW	Hot Water Energy Source
ENPR	Unit Energy Pressure
50	Steam Energy Pressure - 50 PSIG ASME Required
150	Hot Water Energy Pressure - 150 PSIG - ASME Required
400	Hot Water Energy Pressure - 400 PSIG - ASME Required
PVCN	Pressure Vessel Construction
STD	Standard Construction Standard construction (includes ASME LTGN)
PURG	Purge System
AUTO	Automatic Purge System
LGTM	Generator Tubes
SB04	.028 Wall 90-10 CUNI Smooth Surface
SB05	.035 Wall 90-10 CUNI Smooth Surface
SB06	.049 Wall 90-10 CUNI Smooth Surface
SB16	.028 wall 409 SST smooth surface
CDTM	Condenser Tubes
SB09	.028 Wall Copper Smooth Surface
SB10	.035 Wall Copper Smooth Surface
SB04	.028 Wall 90-10 CUNI Smooth Surface
SB05	.035 Wall 90-10 CUNI Smooth Surface
SB06	.049 Wall 90-10 CUNI Smooth Surface
SB17	.028w 316L SST Smooth Surface

EVTM Evaporator Tubes

ES12	.025 Wall Copper Enhanced Surface
ES11	.025 Wall 90-10 CUNI Enhanced Surface
ES05	.035 Wall 90-10 CUNI Enhanced Surface

ABTM Absorber Tubes

SB00	.022 Wall 95-5 CUNI Smooth Surface
SB01	.028 Wall 95-5 CUNI Smooth Surface
SB02	.035 Wall 95-5 CUNI Smooth Surface
SB03	.049 Wall 95-5 CUNI Smooth Surface
SB04	.028 Wall 90-10 CUNI Smooth Surface
SB05	.035 Wall 90-10 CUNI Smooth Surface
SB06	.049 Wall 90-10 CUNI Smooth Surface
SB09	.028 Wall Copper Smooth Surface
SB17	.028 Wall 316L SST Smooth Surface

GNWA LTGN - Generator Water Box Arrangement

GN02	1-Pass Non-Marine RF Flange
GN04	2-Pass Non-Marine RF Flange

CAWA Condenser and Absorber Water Box Arrangement

CA17	150 PSI Marine Victaulic
CA18	150 PSI Marine RF Flange
CA19	150 PSI Non-Marine Victaulic
CA20	150 PSI Non-Marine RF Flange

EVWA Evaporator Water Box Arrangement

EV31	1-Pass 150 PSI Non-Marine Victaulic
EV32	1-Pass 150 PSI Non-Marine RF Flange
EV01	2-Pass 150 PSI Non-Marine Victaulic
EV02	2-Pass 150 PSI Non-Marine RF Flange

CAWC Condenser and Absorber Water Connections

RERE	In right-hand end – out right-hand end (700, 800, 1000, 1100, 1200 tons)
LELE	In left-hand end – out left-hand end (500 tons)
LERE	In left-hand end – out right-hand end (600 and 900 tons)

EVWC Evaporator Water Connections

LEBK	Inlet Connection Left Back
LEFR	Inlet Connection Left Front
REBK	Inlet Connection Right Back
REFR	Inlet Connection Right Front
LEND	In left end, out the other end
REND	In right end, out the other end

CAFT Condenser and Absorber Water Box Fluid Type

WTR	Water
EGLY	Ethylene Glycol Solution
PGLY	Propylene Glycol Solution
EVFT	Evaporator Water Box Fluid Type
WTR	Water
EGLY	Ethylene Glycol Solution
PGLY	Propylene Glycol Solution

Selection Procedure

Product Coding Description

EVLV	Unit Energy Valve	ELPP	Electrical Protection Package
BF02	2-Way 3" 150# Wafer Btrfly	SELP	Standard Electrical Package
BF03	2-Way 4" 150# Wafer Btrfly	PCPO	Control Panel Power Connection
BF04	2-Way 6" 150# Wafer Btrfly	CB	Circuit Breaker
BF05	2-Way 8" 150# Wafer Btrfly	FDS	Fused Disconnect Switch
BF22	3-Way 3" 150# Flanged tee Wafer Btrfly	NFDS	Non-Fused Disconnect Switch
BF23	3-Way 4" 150# Flanged tee Wafer Btrfly	TB	Terminal Block
BF24	3-Way 6" 150# Flanged tee Wafer Btrfly	LCLD	Local Clear Language Display
BF32	3-Way 3" 300# Flanged tee Wafer Btrfly	CLDC	Clear Language Display – Complex Character
BF33	3-Way 4" 300# Flanged tee Wafer Btrfly	CLDO	Clear Language Display – Suitable for Outdoor Use
BF34	3-Way 6" 300# Flanged tee Wafer Btrfly	TRIM	Tracer Interface Control Module
BF42	2-Way 3" 150# Flanged Btrfly	TRMI	Tracer 100 Interface Module (com3)
BF43	2-Way 4" 150# Flanged Btrfly	TRMS	Tracer Summit Interface Module (com4)
BF44	2-Way 6" 150# Flanged Btrfly	PRIM	Printer Interface Control Module
BF45	2-Way 8" 150# Flanged Btrfly	YES	Printer Interface Module
VB01	2-Way 2" 150# Wafer V-Ball	ACWR	Ambient Chilled Water Reset
VB02	2-Way 3" 150# Wafer V-Ball	YES	Ambient Chilled Water Reset
VB03	2-Way 4" 150# Wafer V-Ball	WVUO	Under/Over Phase Voltage Protection
VB11	2-Way 2" 300# Wafer V-Ball	YES	Under/over Voltage Protection
VB12	2-Way 3" 300# Wafer V-Ball	CTWF	Chiller/Tower Water Flow Display
VB13	2-Way 4" 300# Wafer V-Ball	YES	Differential Water Pressure Transducers
VB41	2-Way 2" 150# Flanged V-Ball	OPTM	Options Control Module
VB42	2-Way 3" 150# Flanged V-Ball	YES	Options Module
VB43	2-Way 4" 150# Flanged V-Ball	AFDS	Adjustable frequency drive
EVIN	Unit Energy Valve Installation	YES	Frequency drive
FLD	Field-installed Energy Valve	FLSW	Flow Switches
FACT	Factory-installed Energy Valve	1FS1	150 PSI NEMA 1 Flow Switch - QTY of 1
EVPN	Evaporator Pan construction	1FS2	300 PSI NEMA 1 Flow Switch - QTY of 1
STD	Evaporator Pan – Steel	1FS3	150 PSI NEMA 4 Flow Switch - QTY of 1
SSTL	Evaporator Pan – Stainless Steel	1FS4	300 PSI NEMA 4 Flow Switch - QTY of 1
UPNT	Unit Paint	2FS1	150 PSI NEMA 1 Flow Switch - QTY of 2
SFPT	Standard Factory Paint – Entire Unit	2FS2	300 PSI NEMA 1 Flow Switch - QTY of 2
CSPT	Customer Specified Paint – Entire Unit	2FS3	150 PSI NEMA 4 Flow Switch - QTY of 2
WCNM	Water Chiller Nameplate	2FS4	300 PSI NEMA 4 Flow Switch - QTY of 2
SNMP	Standard ABS Water Chiller Nameplate	LBMF	Lithium Bromide Filter
BNMP	Decorative Brass ABS Water Chiller Nameplate	Yes	Lithium Bromide Filter
SPKG	Unit Shipping Package	UINS	Unit Insulation
DAU	Domestic – Assembled Unit	CINS	Cold Unit Insulation Only
DDG	Domestic – 2-Piece Disassembled Unit	CRPI	Condenser Cross-Over pipe
DAGF	Domestic – Assembled - 2-Piece Field Disassembly	Yes	Condenser cross-over pipe, factory installed
EAU	Export – Assembled Unit		
EDG	Export – 2-Piece Disassembled Unit		
EAGF	Export – Assembled - 2-Piece Field Disassembly		



Performance Data

Table PD-1. Performance data at ARI conditions

Model	Capacity (Tons)	Coefficient of Performance	Steam Rate (lbm/ton/hr)	English Units*			
				Chilled Water		Cond/Abs Water	
				Flow Rate (gpm)	Press. Drop (ft Wtr)	Flow Rate (gpm)***	Press. Drop (ft Wtr)
ABSD500	571	0.71	17.71	1366	19.7	1800	27.4
ABSD600	670	0.72	17.45	1603	30.2	2160	26.6
ABSD700	738	0.71	17.68	1766	22.3	2520	12.2
ABSD800	859	0.72	17.62	2054	32.6	2880	16.6
ABSD975	998	0.71	17.91	2387	18.8	3510	33.5
ABSD1100	1105	0.70	17.98	2643	24.6	3960	20.1
ABSD1225	1238	0.70	17.95	2960	32.7	4410	25.7
ABSD1350	1371	0.71	17.90	3279	42.2	4860	32.2

* 3.6 gpm/nominal ton, Pstm = 12 psig, TctwS = 85°F, TcwS = 44°F, TcwR = 54°F, 0.0001 evap fouling, 0.00025 cond/abs fouling

Model	Capacity (kW)	Coefficient of Performance	Steam Rate (kg/kW-hr)	SI Units**			
				Chilled Water		Cond/Abs Water	
				Flow Rate (m ³ /hr)	Press. Drop (m wg)	Flow Rate (m ³ /hr)	Press. Drop (m wg)
ABSD500	2008	0.71	2.28	310	6.0	409	8.3
ABSD600	2356	0.72	2.25	364	9.2	491	8.1
ABSD700	2595	0.71	2.28	401	6.8	572	3.7
ABSD800	3021	0.72	2.27	466	9.9	654	5.1
ABSD975	3510	0.71	2.31	542	5.7	797	10.2
ABSD1100	3886	0.70	2.32	600	7.5	899	6.1
ABSD1225	4354	0.70	2.31	672	10.0	1002	7.8
ABSD1350	4821	0.71	2.31	745	12.9	1104	9.8

** 0.23 m³/nominal kWh, Pstm = 0.83 bar, TctwS = 29.4°C, TcwS = 6.67°C, TcwR = 12.2°C, 0.018 evap fouling, 0.044 cond/abs fouling

Performance Data

Figure PD-1. ABSD 500-800 capacity vs. chilled-water supply temperature at various cooling-water supply temperatures

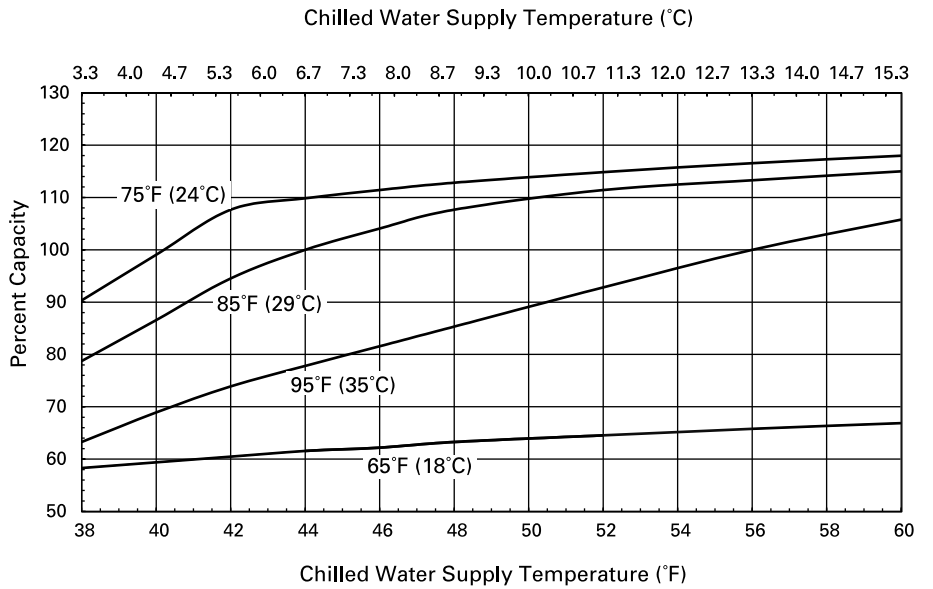
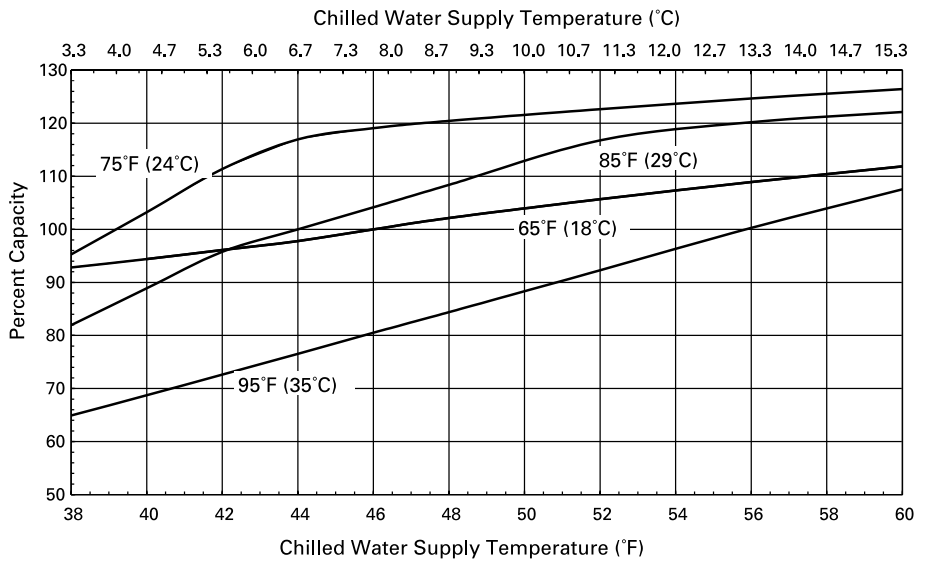
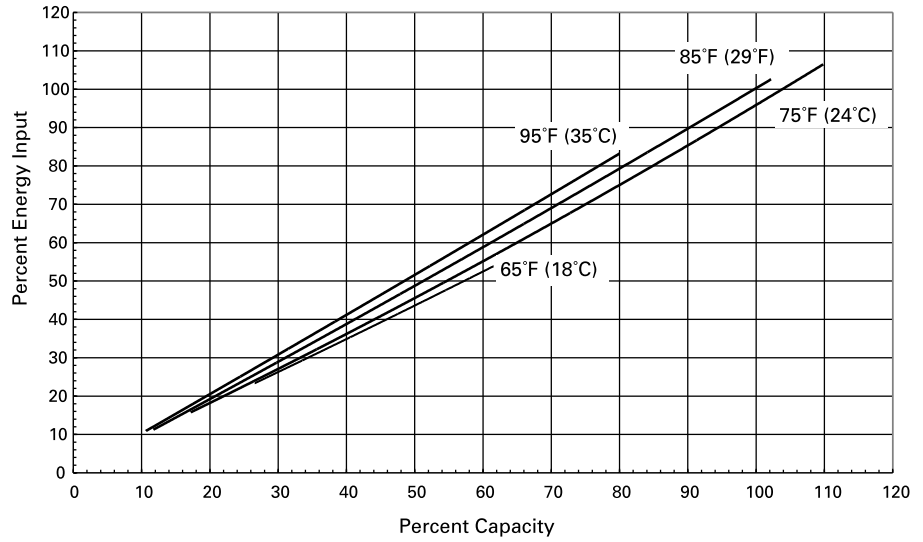

Figure PD-2. ABSD 975-1350 capacity vs. chilled water supply temperature at various cooling water supply temperatures



Performance Data

**Figure PD-3. ABSD 500-800 part load performance - energy input vs. capacity at various cooling water supply temperatures:
chilled water supply temperature = 44°F (7°C)**



**Figure PD-4. ABSD 975-1350 part load performance - energy input vs. capacity at various cooling water supply temperatures:
chilled water supply temperature = 44°F (7°C)**

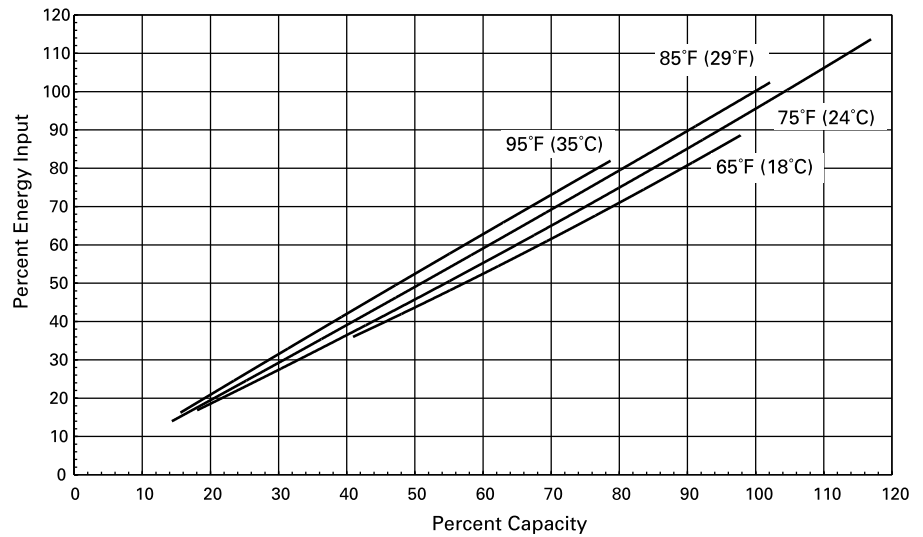

Performance Data

Pressure Drop vs. Water Flow Rate

Figure PD-5. ABSD 500-800 pressure drop vs. chilled water flow rate – English and SI Units

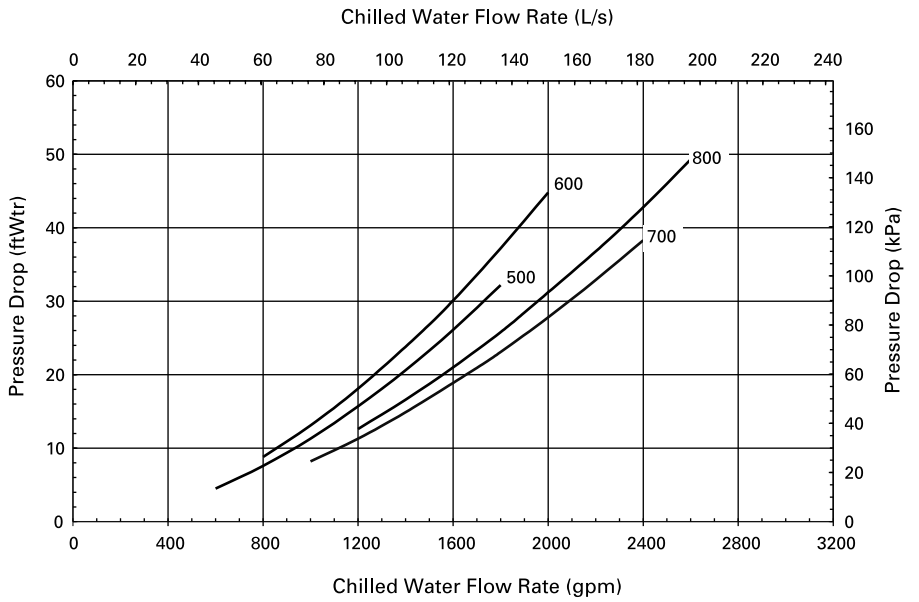
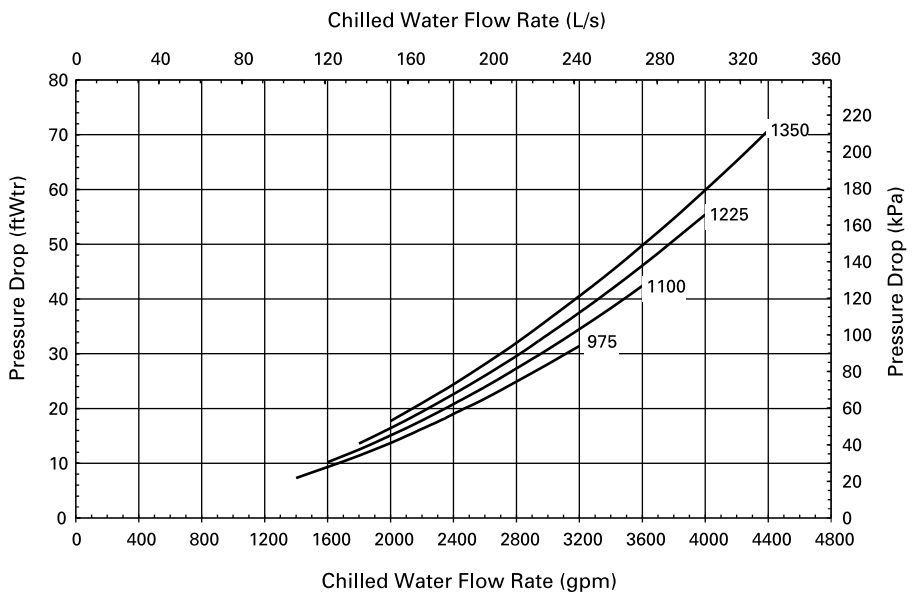

Figure PD-6. ABSD 975-1350 pressure drop vs. chilled water flow rate – English and SI Units





Performance Data

Pressure Drop vs. Water Flow Rate

Figure PD-7. ABSD 500-800 pressure drop vs. cooling water flow rate – English and SI Units

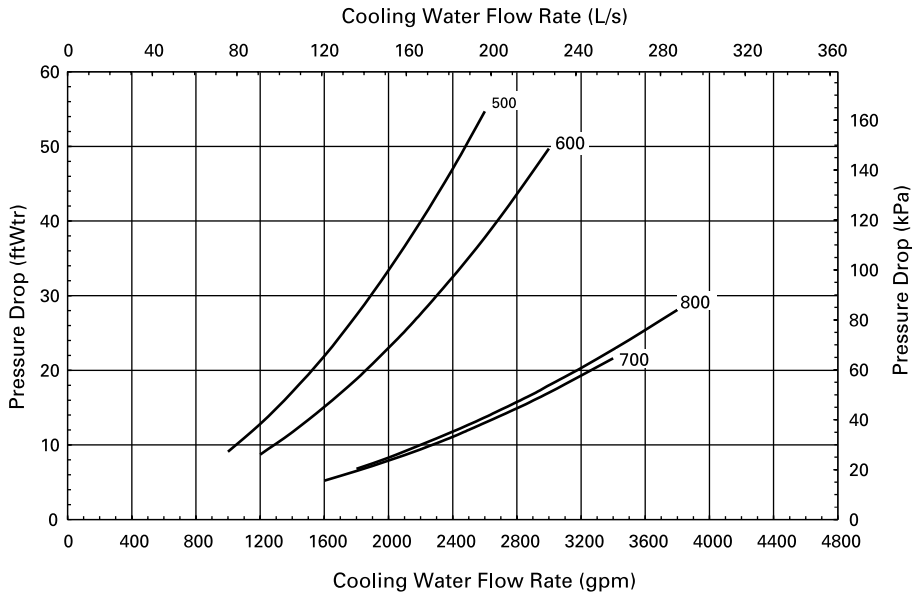
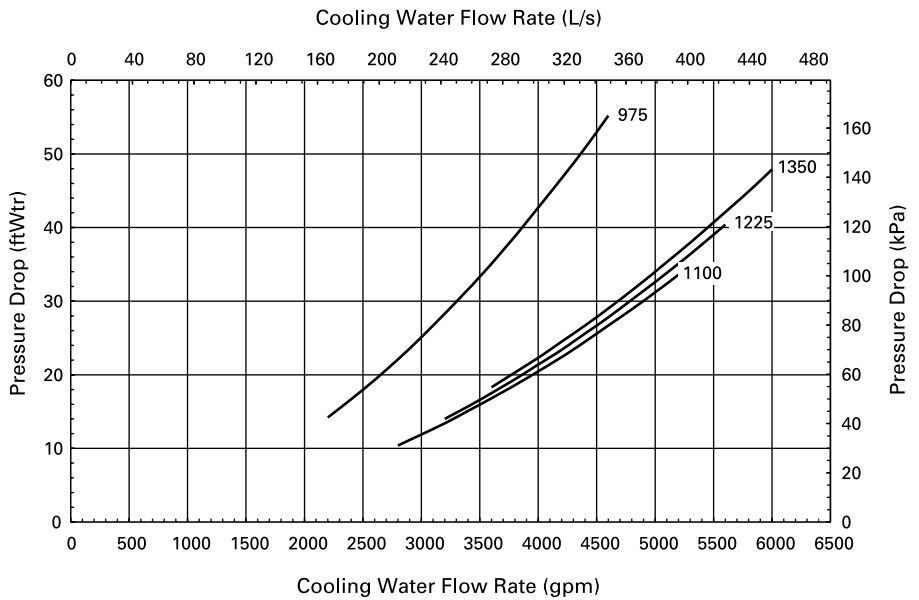

Figure PD-8. ABSD 975-1350 pressure drop vs. cooling water flow rate – English and SI Units



Electrical Data

Electrical Data

Factory-wired and-mounted power control includes main power connections. Total kW includes solution and refrigerant pump, motors, purge pump motor and control panel. Units may be supplied for operation on 230,460 or 575 volt, 3-phase, 60-hertz power, or 190, 220, 380 or 415 volt, 3-phase, 50-hertz power.

Table ED-1. Electrical data

60 Hertz, 3-Phase							
Model	Supply Voltage	FLA	Total Motor HP	Total Motor kW	Control Circuit Amps	MCA	Max Fuse Size Amps
500	200	69.0	13.0	9.7	10.0	86	90
thru	230	60.0	13.0	9.7	8.7	75	80
600	460	30.0	13.0	9.7	4.4	37	40
	575	25.0	13.0	9.7	3.5	31	35
700	200	90.0	17.5	13.0	10.0	109	110
thru	230	78.0	17.5	13.0	8.7	94	100
800	460	39.0	17.5	13.0	4.4	47	50
	575	32.0	17.5	13.0	3.5	39	40
975	200	90.0	17.5	13.0	10.0	109	110
	230	78.0	17.5	13.0	8.7	94	100
	460	39.0	17.5	13.0	4.4	47	50
	575	32.0	17.5	13.0	3.5	39	40
1100	200	96.0	20.0	14.9	10.0	115	125
thru	230	84.0	20.0	14.9	8.7	100	110
1350	460	42.0	20.0	14.9	4.4	50	60
	575	34.0	20.0	14.9	3.5	41	45
50 Hertz, 3-Phase							
Model	Supply Voltage	FLA	Total Motor HP	Total Motor kW	Control Circuit Amps	MCA	Max Fuse Size Amps
500	190	62.0	13.0	9.7	10.5	79	80
thru	220	52.4	13.0	9.7	9.1	67	70
600	380	30.0	13.0	9.7	5.3	38	40
	415	27.5	13.0	9.7	4.8	35	35
700	190	67.0	15.5	11.6	10.5	85	90
thru	220	57.4	15.5	11.6	9.1	73	80
800	380	33.0	15.5	11.6	5.3	42	45
	415	30.5	15.5	11.6	4.8	39	40
975	190	80.0	17.5	13.0	10.5	98	100
	220	68.0	17.5	13.0	9.1	84	90
	380	39.0	17.5	13.0	5.3	48	50
	415	36.0	17.5	13.0	4.8	44	45
1100	190	85.0	20.0	14.9	10.5	103	110
thru	220	73.0	20.0	14.9	9.1	89	90
1350	380	42.0	20.0	14.9	5.3	51	60
	415	39.0	20.0	14.9	4.8	47	50

Electrical Data

Wiring

GENERAL NOTES:

1. THIS DRAWING IS TO BE USED FOR THE PURPOSE OF ESTIMATING FIELD WIRING REQUIREMENTS. CHECK SALES ORDER TO DETERMINE WHICH OPTIONS ARE SPECIFIED AND REFER TO FIELD CONNECTION WIRING DIAGRAM FOR ACTUAL FIELD WIRING REQUIRED. DASHED LINES INDICATE DEVICES AND FIELD WIRING SUPPLIED BY CUSTOMER.
2. ALL FIELD WIRING MUST BE IN ACCORDANCE WITH THE NATIONAL ELECTRIC CODE OR STATE AND LOCAL REQUIREMENTS WHICH APPLY. ALL CUSTOMER CONTROL CIRCUIT WIRING MUST HAVE A MINIMUM RATING OF 150 VOLTS.
3. DO NOT ROUTE LOW VOLTAGE (30 VDC MAXIMUM) WIRING IN THE SAME CONDUIT AS CONTROL VOLTAGE (115 VAC) WIRING AND DO NOT POWER-UP UNIT UNTIL CHECK-OUT AND START-UP PROCEDURES HAVE BEEN COMPLETED.
4. THE MAIN UNIT CONTROL PANEL PROVIDES A CONTACT CLOSURE TO CONTROL THE INDICATED CUSTOMER CONNECTED DEVICE. CUSTOMER TO PROVIDE 115 VAC POWER TO EACH DEVICE. MAXIMUM FUSE SIZE IS 15 AMPS.

REQUIRED WIRING NOTES:

5. TRANE PROVIDES A TERMINAL BLOCK, FUSED OR NON-FUSED DISCONNECT SWITCH OR A CIRCUIT BREAKER IN THE MAIN UNIT CONTROL PANEL FOR LINE VOLTAGE CONNECTION WHICH REQUIRES THE USE OF COPPER CONDUCTORS ONLY. CHECK SALES ORDER TO DETERMINE WHICH OPTION IS SPECIFIED. WIRING SIZED PER NATIONAL ELECTRIC CODE BASED ON NAMEPLATE MINIMUM CIRCUIT AMPACITY RATING.
6. EVAPORATOR AND CONDENSER FLOW SWITCHES ARE TO BE INSTALLED AND WIRED TO THE MAIN UNIT CONTROL PANEL BY THE INSTALLING CONTRACTOR. THE PURCHASE OF FLOW SWITCHES FROM TRANE IS OPTIONAL. EACH FLOW SWITCH CIRCUIT REQUIRES TWO WIRES, 115 VAC. MINIMUM CONTACT RATING AT 115 VAC IS 4.8 MA.
7. CHILLED AND CONDENSER-ABSORBER WATER FLOW MUST BE PROVEN PRIOR TO CHILLER OPERATION. CONDENSER-ABSORBER WATER PUMP MUST BE CONTROLLED BY THE MAIN UNIT CONTROL PANEL FOR CHILLER SAFETY.
8. CIRCUIT REQUIRES TWO WIRES, 115 VAC. MAXIMUM MODULE CONTACT RATING AT 115 VAC OR 30 VDC IS 2.88 AMPS INDUCTIVE, 1/3 HP.

OPTIONAL WIRING NOTES:

9. OPTIONAL CONTROL FOR A CUSTOMER SPECIFIED OR INSTALLED LATCHING TRIP-OUT. THE CHILLER WILL RUN NORMALLY WHEN THE CONTACT IS CLOSED AND TRIP THE CHILLER OFF WITH A MANUALLY RESETTABLE DIAGNOSTIC WHEN THE CONTACT OPENS. MANUAL RESET IS ACCOMPLISHED WITH THE DIAGNOSTIC KEY ON THE FRONT OF THE MAIN UNIT CONTROL PANEL. CUSTOMER SUPPLIED SILVER CONTACTS ARE REQUIRED FOR 24 VDC, 12 MA RESISTIVE LOAD. CIRCUIT REQUIRES TWO WIRES, 30 VDC MAXIMUM. DO NOT ROUTE IN CONDUIT WITH HIGHER VOLTAGE CIRCUITS.
10. OPTIONAL CONTROL FOR A CUSTOMER SPECIFIED OR INSTALLED REMOTE AUTO-STOP FUNCTION. THE CHILLER WILL RUN NORMALLY WHEN THE CONTACT IS CLOSED AND STOP THE CHILLER WHEN THE CONTACT OPENS. RECLOSURE OF THE CONTACT WILL PERMIT THE CHILLER TO AUTOMATICALLY RETURN TO NORMAL OPERATION. CUSTOMER SUPPLIED SILVER CONTACTS ARE REQUIRED FOR 24 VDC, 12 MA RESISTIVE LOAD. CIRCUIT REQUIRES TWO WIRES, 30 VDC MAXIMUM. DO NOT ROUTE IN CONDUIT WITH HIGHER VOLTAGE CIRCUITS.
11. CIRCUIT REQUIRES TWO WIRES, 115 VAC. NORMALLY OPEN MAXIMUM MODULE CONTACT RATING AT 115 VAC OR 30 VDC IS 2.88 AMPS INDUCTIVE, 1/3 HP.
12. CIRCUIT REQUIRES SHIELDED WIRE PAIR, 30 VDC MAXIMUM. BELDON TYPE 8760 RECOMMENDED. MAXIMUM LENGTH OF 5000 FEET.
13. TRANE PROVIDES STEAM PRESSURE TRANSDUCER SHIELDED CABLE ASSEMBLIES FOR FIELD INSTALLATION BY CUSTOMER.

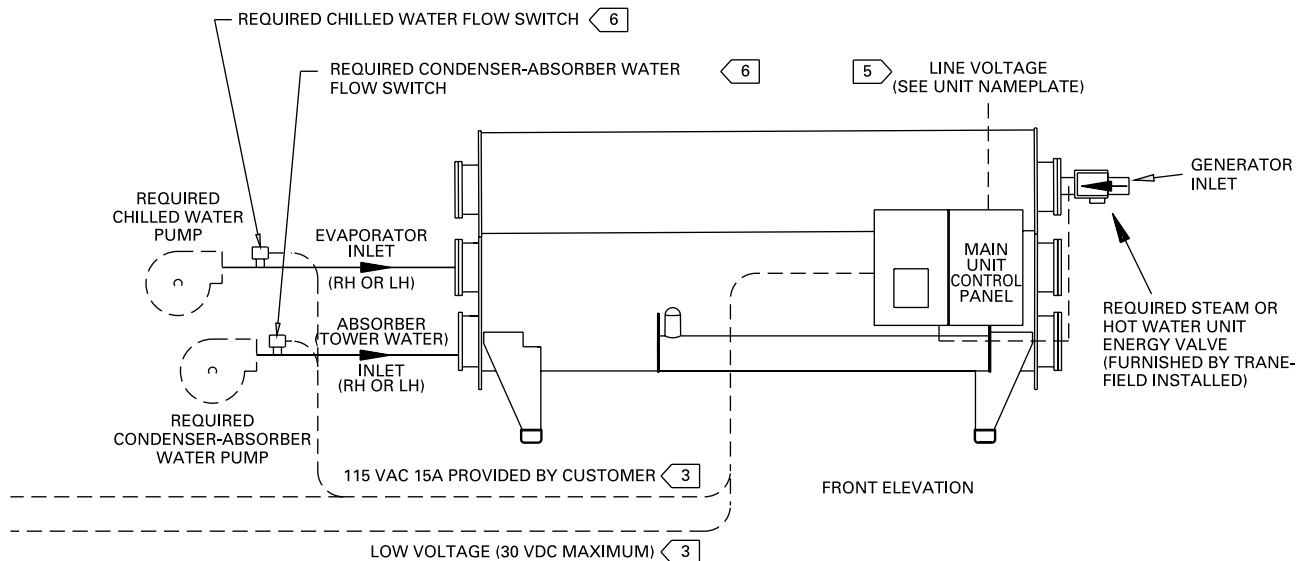

Controls Data

Setting The Standards

Trane set the standard for unit microprocessor controls in 1985 with the first generation of Unit Control Panel.

Associated with this standard have been:

- Proportional Integral Derivative (PID) control strategies, which provide stable operation and high accuracy for better performance, along with feed forward plus;
- Adaptive Control™ to keep the chiller “on line” and at the same time keep the chiller away from a major failure;
- Software based safeties that do not depend on electromechanical hardware – hardware that means questionable reliability and added cost;
- Operator interface that accesses chiller information and control adjustments at the front of the panel.

UCP2™

UCP2 adds more flexibility, more reliability and better system performance than even our most demanding customers expect.

Flexibility

Trane offers the ability to adapt to changes easily and effectively without adding prohibitive cost. To provide flexibility, the controller responds to a wide variety of needs for:

- **System Designs**, including equipment, operating conditions and controls variations that are either existing or being considered for new installations.

Key to designing non-traditional systems is the ability to evaluate the cost and reliability issues of these systems in comparison to the more traditional systems. Trane recommends the use of C.D.S. Network Equipment Economics, the Trane Applications Manuals and consultation with a Trane sales engineer for help in this analysis.

- **System Upgrades**, including the ability to accommodate changes in the chilled-water system design or equipment room requirements, or to accommodate new technologies that become available.

- Modular structure of the UCP2 makes it possible for the designer to select the system controls and associated interfaces to Tracer® (or other building automation systems) that are required for the chiller plant design. With this modular concept, capability can be added or upgraded at any time, with only temporary interruption of chilled-water production.
- The operator can quickly program a Custom Report — so that only what are considered to be the most frequently accessed/important reports are available — at any time, right at the front of the panel.
- With easy front panel programmability of Daily, Service Start-up and Machine Configuration settings and setpoints, the operator, serviceman and system designer can customize the use of the micro controller to unique conditions of the chiller plant — whether the purpose of chilled water is for comfort cooling or for process cooling.
- All data that is necessary for the safe operation and easy serviceability of the chiller is provided as standard on all Horizon® absorption chillers. Options are available that provide additional controls/data that are required for: an industrial/process system design, applications outside of the typical chilled water system design, the need for redundant machine protection or the desire for more system information.

Controls Data

Reliability

To most people, reliability means “dependability — giving the same result on successive trials.” To our customers, however, it has come to mean “keep chilled water flowing.” In other words, “when I turn the switch on, cold water comes out.” In order to do this, the micro controller must be aware of what is happening in the system. But more importantly, it must be able to make decisions and adjustments to keep the chiller running as long as possible, even when non-standard conditions exist — conditions such as bad power, bad water (flow, temperature, fouling) or system component failure. Also, the Trane UCP2 panel continuously monitors for noncondensables and purges automatically.

- With Enhanced Adaptive Control™ the controller does everything it can to avoid taking the chiller offline.
 - Senses evaporator temperature limit and high temperature limit
 - Displays a warning message about the potential condition/safety trip
 - Takes the following corrective action sequentially as the condition worsens:
 - limits loading
 - prevents further loading
 - unloads until condition improves
 - takes chiller offline
- With more diagnostics and diagnostic history that are time/date stamped and with help messages, the operator or serviceman can take faster and more effective corrective action.

System Performance

“Chilled Water System” encompasses many levels of control: Standalone Chiller, Chiller Plant, Applied System, Central Building Automation System. However, regardless of the system level being designed, the unit controls become critical, not just in making every level operate reliably but also in facilitating optimal performance. UCP2 provides more capability and more intelligence to make this operation/optimization possible.

Panel Features:

The absorption chiller Unit Control Panel (UCP2) incorporates the following features and components:

Control Functions

- Smart dilution-cycle duration based on system requirements
- Adaptive evaporator leaving-fluid temperature control
- Low evaporator-temperature limit
- High solution-temperature limit
- Solution flow control via AFD
- Soft loading
- Nuisance trip prevention via Adaptive Control
- Chilled-water reset
- Optimum concentration control
- Crystallization recovery via SDR

Controls Data

Safeties

- Smart shutdown sequence: condenser/absorber loss of flow
- Low condenser/absorber water temperature
- High-pressure cutout
- Evaporator leaving-fluid temperature cutout
- Motor current overload
- High motor-winding temperature
- Over/under voltage (optional)
- Purge limit
- Sensor failure detection

Monitored Points

Chiller information is available at the operator interface via a clear language display. Access to the information is through four dedicated report keys: Customer, Chiller, Cycle and Pump/Purge.

Customer Report

User-defined custom report (operator may choose up to 20 points from a list of over 100 choices).

Chiller Report

Status, fluid temperatures, and setpoints:

- Operating mode (i.e. run status)
- Chilled-water setpoint
- Evaporator entering/leaving water temperatures
- Absorber entering/leaving water temperatures
- Condenser leaving-water temperature
- outdoor air temperature
- Evaporator leaving-water temperature
- Chilled-water reset

Cycle Report

Refrigerant temperatures and pressures:

- Solution temperature leaving generator
- Solution temperature entering generator
- Generator-leaving concentration
- Generator cutout and monitor temperature
- Crystallization detection temperature
- Crystallization trip temperature
- Saturated condenser refrigerant temperature
- Absorber-entering concentration
- LiBr crystallization margin
- Solution temperature entering absorber
- Absorber spray temperature
- Solution temperature leaving absorber
- Saturated evaporator refrigerant temperature
- Evaporator leaving-water temperature
- Evaporator entering-water temperature
- Absorber entering-water temperature
- Absorber leaving-water temperature
- Condenser leaving-water temperature
- Solution pump auto/manual speed command
- Energy input auto/manual/slaved reported command
- Steam Supply Pressure
- Generator Steam Pressure

Pump/Purge Report

- Solution pump
 - Counters for starts and hours
 - Motor phase currents
 - Motor phase voltages (optional)
- Purge Pump
 - Operating mode and status
 - Refrigerant suction temperature
 - Pumpout rate
 - Total pumpout time
 - Service log

Controls Data

Diagnostics

The absorption chiller Unit Control Panel (UCP2) provides over 70 different diagnostics such as:

- Water and refrigerant/solution temperatures out of range
- Loss of system waterflows
- Sensor and switch faults
- Overload trips
- Over/under voltage (optional)
- Crystallization recovery
- Emergency stop
- Loss of communication to other modules
- Motor abnormal

Operator Interface

The Trane Horizon® steam-fired absorption chiller control panel, UCP2, is easy to use, understand, access information, read, change setpoints, diagnose problems, maintain, and to reset after shutdown.

Convenience

Enunciation of all information is at the front panel display (including power, voltage, amps, purge pressures, and number of starts data). Messages are displayed using clear language.

Readability

- Two-line, 40-character display that is easy to read from within a 60-degree angle
- LCD backlight so that the display can be read in a variety of equipment-room lighting
- Seven languages available
- Metric (SI) units available
- Complete character human interface available

Ease of Use

- Keypad programmability — no manual switches or setpoint potentiometers
- Logically arranged report groups with report header and setpoint groups
- Selectable security
- Variable points updated every two seconds
- Messages that direct user to problem source via a menu item

Trane ICS Compatibility

The Trane absorption chiller control panel, UCP2, is 100 percent compatible with the Trane Integrated Comfort™ systems, ICS, UCP2 easily integrates into the Tracer® family of flexible chiller-plant system controllers with a single twisted-wire pair communications cable.

For more information on the Trane absorption chiller unit control panel, please contact your local Trane sales engineer.

Dimensions and Weights

Physical Dimensions

ABSD 500, 600, 700, 800 Physical Dimensions English and SI Units

This section provides the overall dimensions of the Horizon absorption chiller. See unit submittal drawings for configured water nozzle connection dimensions. A 500 Ton 2 pass absorber and condenser is illustrated. All catalog dimensional drawings are subject to change. Current submittal drawings should be referred to for detailed dimensional information. Contact the local Trane sales office for submittal and template information.

Table DW-1. Dimensional data

Unit	English Units					
	A	B	C	D	E	F
500	13'-9½"	14'-5½"	1'-7 ² / ₈ "	17'-9¾"	14'-2 ¹ / ₈ "	8'-0 ⁷ / ₈ "
600	16'-5½"	17'-1½"	1'-8 ⁷ / ₈ "	20'-7¼"	16'-10 ¹ / ₈ "	10'-8 ⁷ / ₈ "
700	19'-1 ³ / ₈ "	19'-9½"	1'-8 ⁷ / ₈ "	23'-3¼"	19'-6 ¹ / ₈ "	13'-11 ¹ / ₈ "
800	21'-9 ³ / ₈ "	22'-5½"	1'-8 ⁷ / ₈ "	25'-11¼"	22'-2 ¹ / ₈ "	16'-10 ⁷ / ₈ "
Unit	SI Units					
	A	B	C	D	E	F
500	4204	4407	492	5429	4321	2461
600	5017	5220	530	6280	5134	3273
700	5826	6033	530	7093	5947	4245
800	6639	6845	530	7906	6760	5153

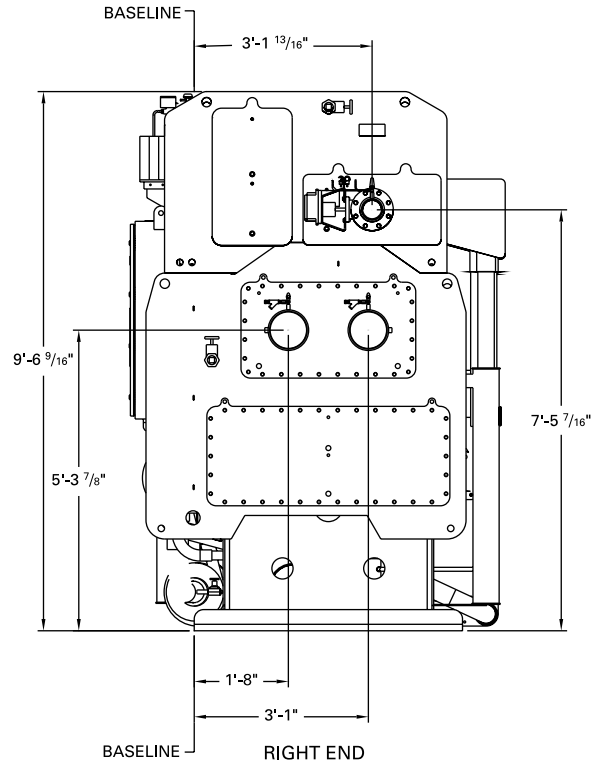
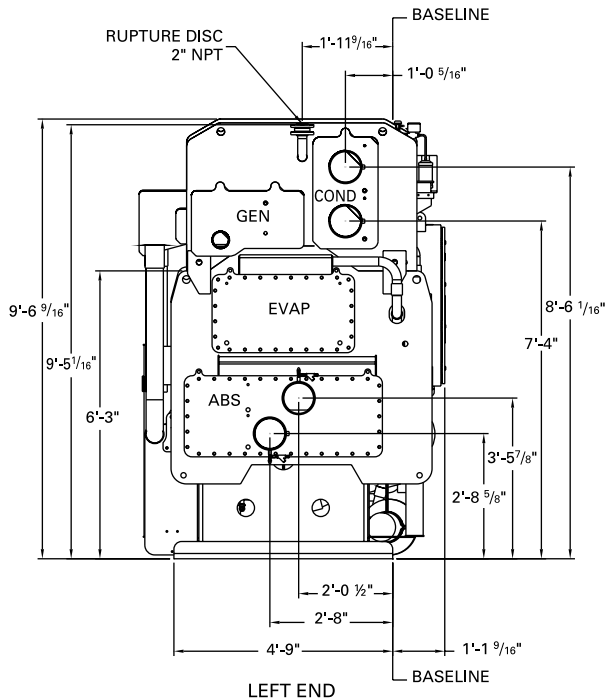

Dimensions and Weights

Physical Dimensions

**Table DW-2. English to SI Units
Cross Reference
Conversion Chart
(Ft. to mm)**

English Units	SI Units
1 7/8"	48
2"	51
1' 0 5/16"	313
1' 1 1/2"	343
1' 1 9/16"	344
1' 3 1/2"	394
1' 8"	508
1' 8 7/8"	530
1' 11 9/16"	598
2' 0 1/2"	622
2' 8"	813
2' 8 5/8"	829
3' 1"	940
3' 1 3/4"	959
3' 1 13/16"	960
3' 5 7/8"	1064
3' 6"	1067
3' 9"	1143
4' 0 1/8"	1222
4' 6"	1372
4' 9"	1448
5' 3 7/8"	1622
6' 3"	1905
7' 4"	2235
7' 5 7/16"	2272
8' 6 1/16"	2593
9' 5 1/16"	2886
9' 6 9/16"	2910

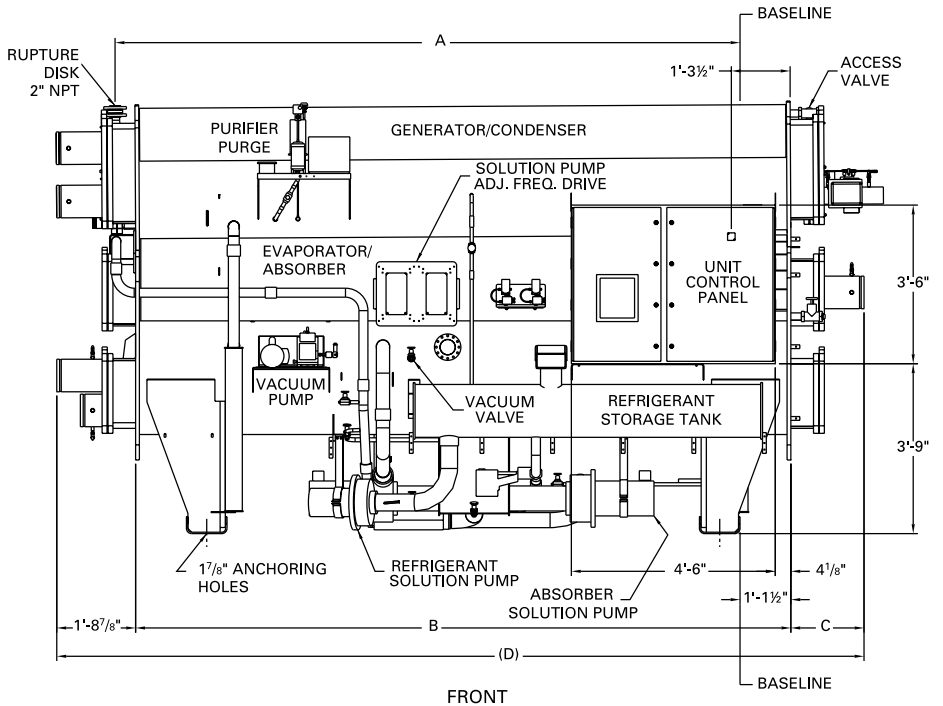
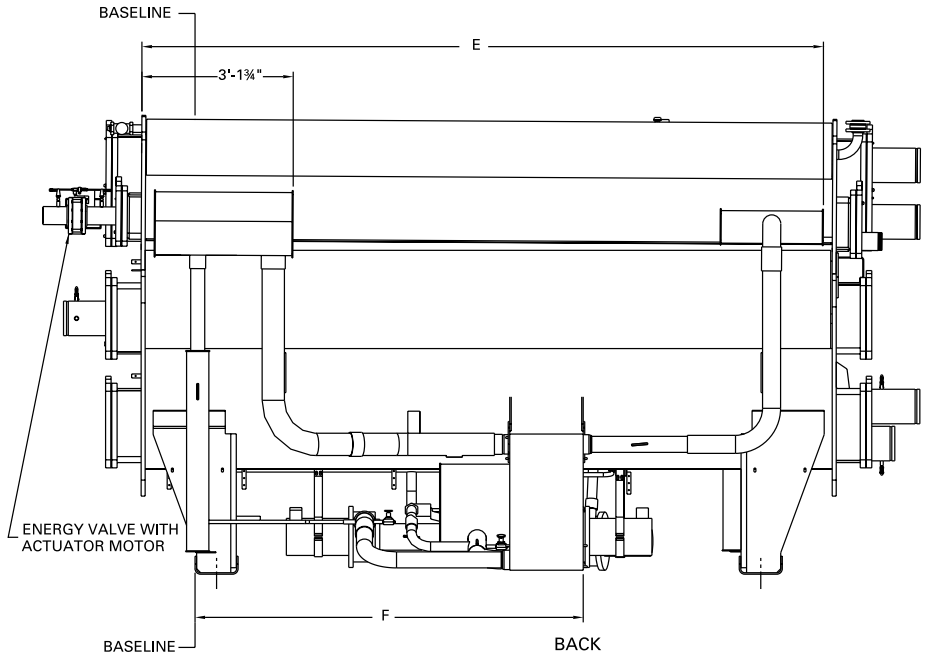



Dimensions and Weights

Physical Dimensions

ABSD 975, 1100, 1225, 1350 Physical Dimensions English and SI Units

This section provides the overall dimensions of the Horizon absorption chiller. See unit submittal drawings for configured water nozzle connection dimensions. All catalog dimensional drawings are subject to change. Current submittal drawings should be referred to for detailed dimensional information. Contact the local Trane sales office for submittal and template information.

Table DW-3. Dimensional data

English Units					
Unit	A	B	D	E	F
975	17' - 7 1/2"	18' - 0"	21' - 8"	17' - 3"	N/A
1100	19' - 7 1/2"	20' - 0"	23' - 8"	19' - 3"	N/A
1225	21' - 7 1/2"	22' - 0"	25' - 8"	21' - 3"	N/A
1350	23' - 7 1/2"	24' - 0"	27' - 8"	23' - 3"	N/A
SI Units					
Unit	A	B	D	E	F
975	5372	5486	6604	5258	N/A
1100	5982	6096	7214	5868	N/A
1225	6591	6705	7823	6477	N/A
1350	7201	7315	8433	7087	N/A

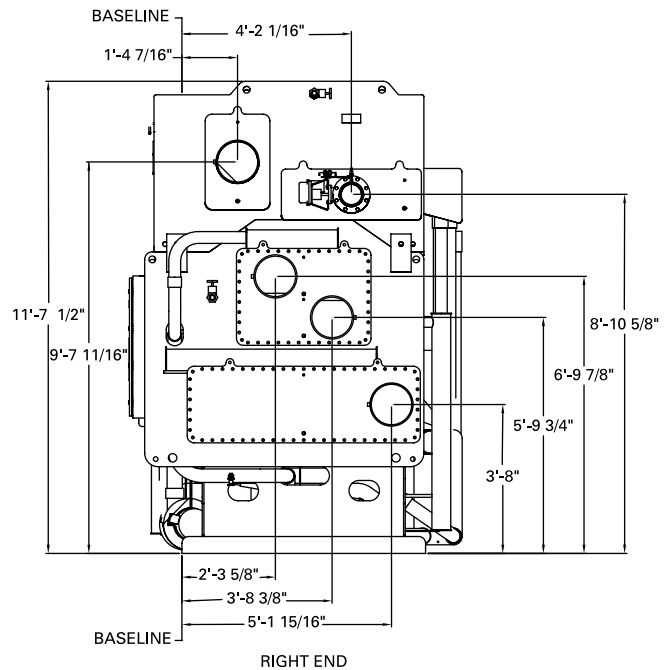
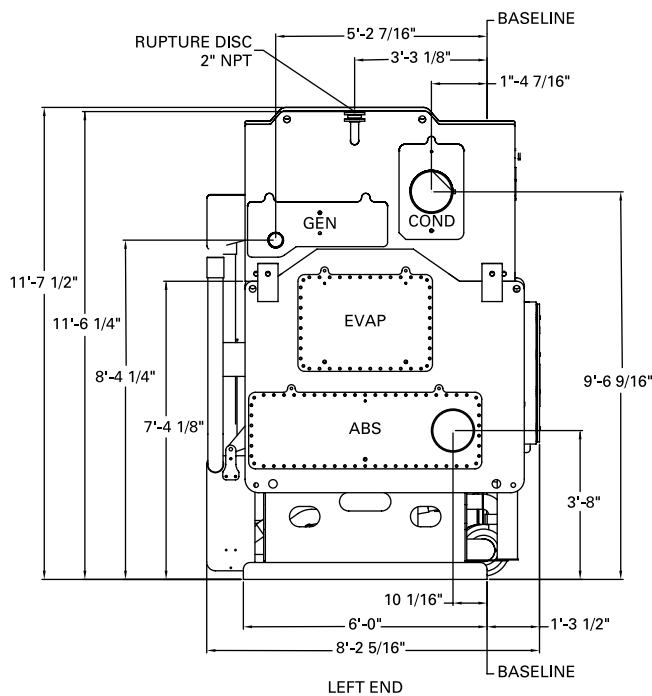

Dimensions and Weights

Physical Dimensions

**Table DW-4. English to SI Units
Cross Reference**

Conversion Chart (Ft. to mm)	
English Units	SI Units
4' - 2 1/16"	50
2"	51
3 1/4"	83
9 1/2"	241
10 1/16"	256
1' - 2 3/4"	375
1' - 3 1/2"	394
1' - 4 7/16"	418
1' - 9 7/8"	556
2' - 3 5/8"	702
3' - 3 1/8"	994
3' - 4"	1016
3' - 6"	1067
3' - 8"	1118
4' - 6"	1372
5' - 1 15/16"	1573
5' - 2 7/16"	1586
5' - 9 3/4"	1772
6' - 0"	1829
6' - 9 7/8"	2080
7' - 4 1/8"	2238
8' - 2 5/16"	2497
8' - 4 1/4"	2546
8' - 10 5/8"	2708
9' - 6 9/16"	2910
9' - 7 11/16"	2938
11' - 6 1/4"	3512
11' - 7 1/2"	3543

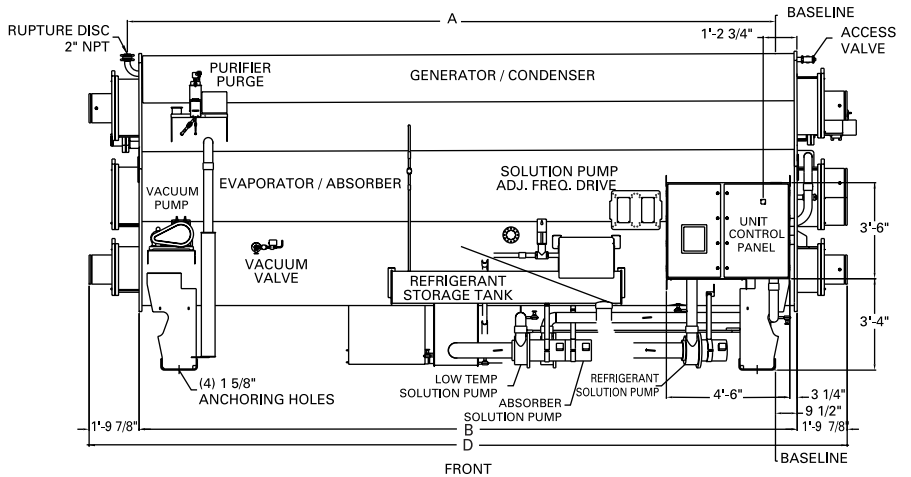
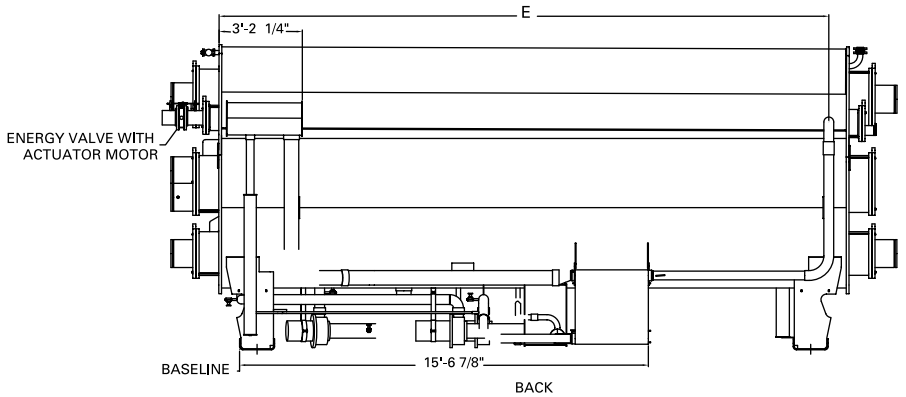

Dimensions and Weights

Disassembly Options

Separated Machine Sections

Disassembled machines can ship to the job site in two main sections, the evaporator/ absorber as a section and the low temperature generator/ condenser as a separate section. Contact the local Trane sales office for current submittal information.

Figure DW-1. Disassembly options – right end view

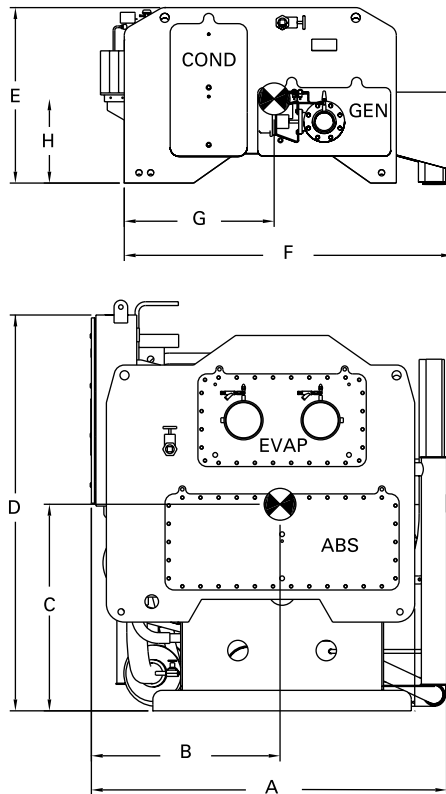

Table DW-5. Disassembly and center of gravity dimensions

Unit Size	500	600	700	800	975	1100	1225	1350
English Units								
A	5' 11 1/4"	5' 11 1/4"	5' 11 1/4"	5' 11 1/4"	8'-2 3/8"	8'-2 3/8"	8'-2 3/8"	8'-2 3/8"
B	3' 5 5/8"	3' 5 5/8"	3' 5 5/8"	3' 5 5/8"	3'-11 1/4"	3'-11 1/4"	3'-11 1/4"	3'-11 1/4"
C	3' 9 3/8"	3' 10"	3' 10 1/8"	3' 10 3/8"	4'-8 3/4"	4'-8 3/4"	4'-8 3/4"	4'-8 3/4"
D*	7' 3"	7' 3"	7' 3"	7' 3"	8'-2 5/8"	8'-2 5/8"	8'-2 5/8"	8'-2 5/8"
E	3' 2 5/8"	3' 2 5/8"	3' 2 5/8"	3' 2 5/8"	4'-2 3/8"	4'-2 3/8"	4'-2 3/8"	4'-2 3/8"
F	6' 0 3/8"	6' 0 3/8"	6' 0 3/8"	6' 0 3/8"	7'-7"	7'-7"	7'-7"	7'-7"
G	2' 9"	2' 9"	2' 9"	2' 9"	3'-8 1/2"	3'-8 1/2"	3'-8 1/2"	3'-8 1/2"
H	1' 6 1/2"	1' 6 1/2"	1' 6 1/2"	1' 6 1/2"	2'-0 3/8"	2'-0 3/8"	2'-0 3/8"	2'-0 3/8"
SI Units (mm)								
A	1810	1810	1810	1810	2499	2499	2499	2499
B	1057	1057	1057	1057	1200	1200	1200	1200
C	1153	1168	1172	1178	1441	1441	1441	1441
D	2210	2210	2210	2210	2505	2505	2505	2505
E	981	981	981	981	1280	1280	1280	1280
F	1838	1838	1838	1838	2311	2311	2311	2311
G	838	838	838	838	1130	1130	1130	1130
H	470	470	470	470	619	619	619	619

*Indicates overall height of chiller. The top of the evaporator shell is the highest point on chiller sizes 975-1350 tons. The top of the control panel is the highest point on chillers 800 tons and below.

Dimensions and Weights

Rigging

Foundation Support

The foundation must be level, smooth, and capable of supporting the machine weight. The machine legs should be positioned over isolation pads. A housekeeping pad or support rail is recommended to elevate the machine for maintenance. Any foundation pad should provide adequate structural support and keep the installed machine level within 1/16-inch [1.6 mm] by length and width for reliable operation. Leveling marks on the evaporator and absorber tube sheet can be used to check the machine after it is positioned on the pad.

Chiller Isolation

Isolation pads are provided with each unit. The purpose of the isolation pad is to distribute the machine weight and minimize sound and vibration transmission through the building structure.

Figure DW-2. Typical machine rigging points

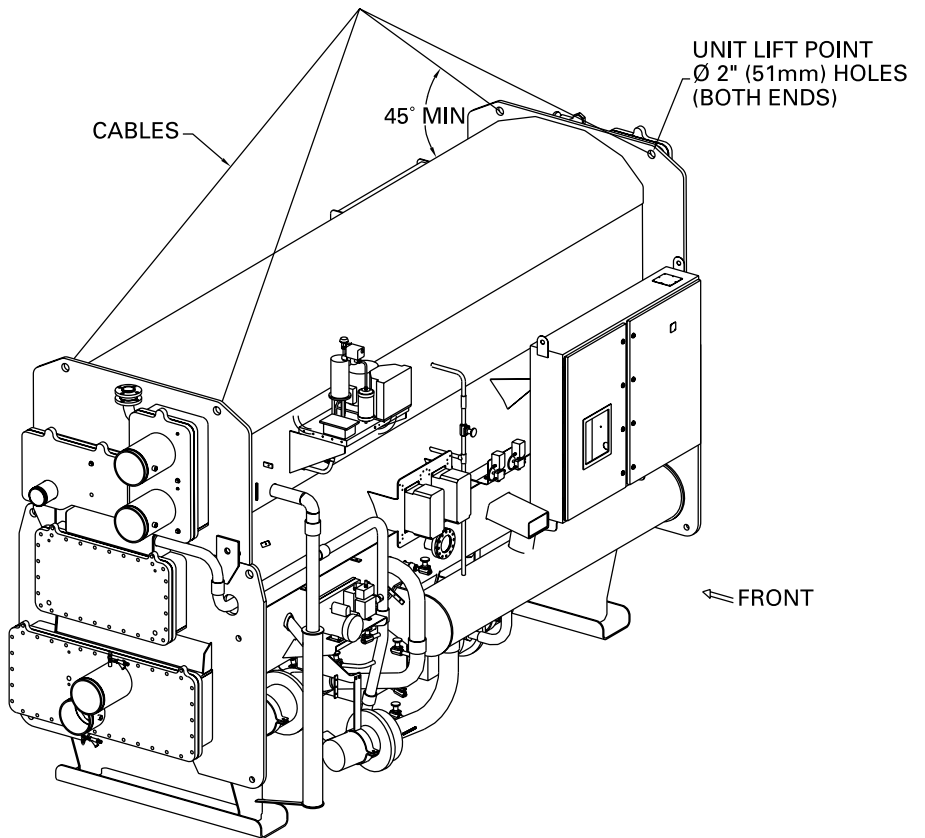
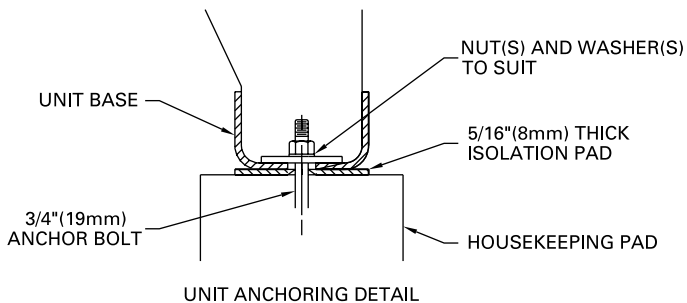

Figure DW-3. Unit anchoring detail - all sizes



Dimensions and Weights

Service Clearances

Figure DW-4. Service clearances

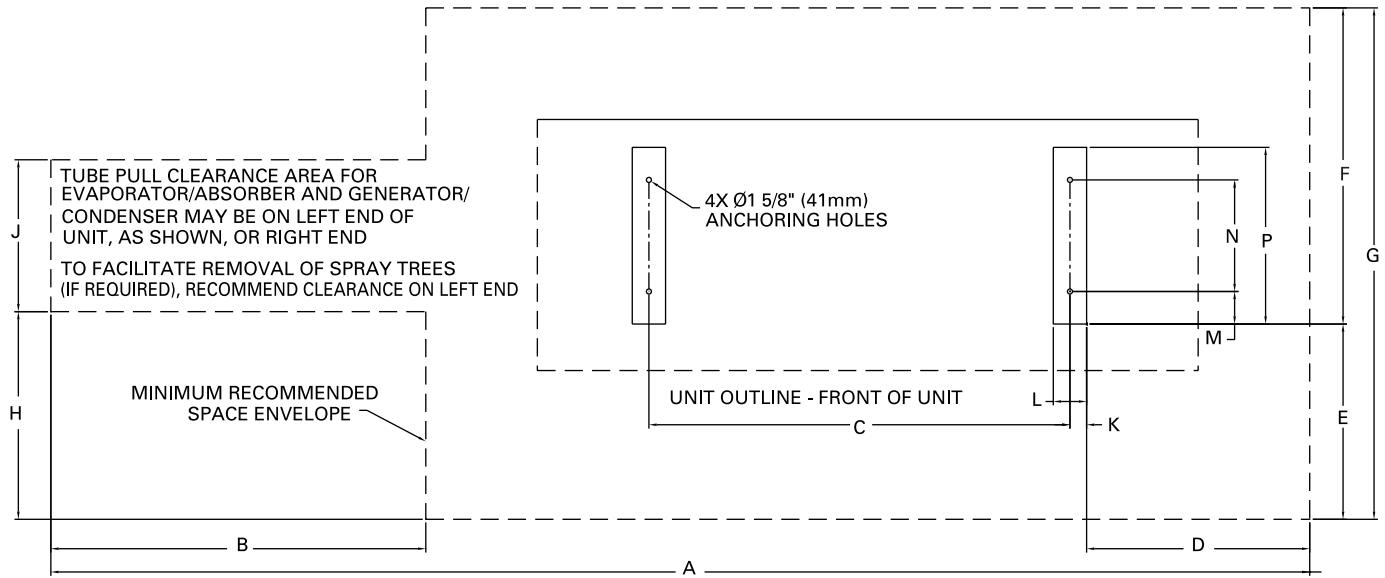

Dimensions and Weights

Service Clearances

Table DW-6. Service clearances

English Units								
Unit Size	500	600	700	800	975	1100	1225	1350
A	33' - 10 1/4"	39' - 2 1/4"	44' - 6 1/4"	49' - 10 1/4"	40' - 11 7/8"	44' - 11 7/8"	48' - 11 7/8"	52' - 11 7/8"
B	10' - 1"	12' - 9"	15' - 5"	18' - 1"	13' - 4 1/8"	15' - 4 1/8"	17' - 4 1/8"	19' - 4 1/8"
C	11' - 3 7/8"	13' - 11 7/8"	16' - 7 7/8"	19' - 3 7/8"	15' - 1"	17' - 1"	19' - 1"	21' - 1"
D	6' - 0"	6' - 0"	6' - 0"	6' - 0"	5' - 7 3/8"	5' - 7 3/8"	5' - 7 3/8"	5' - 7 3/8"
E	5' - 3"	5' - 3"	5' - 3"	5' - 3"	5' - 3 1/2"	5' - 3 1/2"	5' - 3 1/2"	5' - 3 1/2"
F	8' - 6"	8' - 6"	8' - 6"	8' - 6"	9' - 10 1/8"	9' - 10 1/8"	9' - 10 1/8"	9' - 10 1/8"
G	13' - 9"	13' - 9"	13' - 9"	13' - 9"	15' - 2 3/8"	15' - 2 3/8"	15' - 2 3/8"	15' - 2 3/8"
H	5' - 7"	5' - 7"	5' - 7"	5' - 7"	5' - 7 3/8"	5' - 7 3/8"	5' - 7 3/8"	5' - 7 3/8"
J	4' - 1"	4' - 1"	4' - 1"	4' - 1"	5' - 4 1/4"	5' - 4 1/4"	5' - 4 1/4"	5' - 4 1/4"
K	5 3/8"	5 3/8"	5 3/8"	5 3/8"	8"	8"	8"	8"
L	10 3/4"	10 3/4"	10 3/4"	10 3/4"	16"	16"	16"	16"
M	10 1/2"	10 1/2"	10 1/2"	10 1/2"	10"	10"	10"	10"
N	3' - 0"	3' - 0"	3' - 0"	3' - 0"	4' - 4"	4' - 4"	4' - 4"	4' - 4"
P	4' - 9"	4' - 9"	4' - 9"	4' - 9"	6' - 0"	6' - 0"	6' - 0"	6' - 0"
SI Units (mm)								
Unit Size	500	600	700	800	975	1100	1225	1350
A	10319	11944	13570	15196	12494	13713	14932	16151
B	3073	3886	4699	5512	4067	4677	5286	5896
C	3451	4264	5077	5890	4597	5207	5817	6426
D	1829	1829	1829	1829	1711	1711	1711	1711
E	1600	1600	1600	1600	1613	1613	1613	1613
F	2591	2591	2591	2591	3019	3019	3019	3019
G	4191	4191	4191	4191	4632	4632	4632	4632
H	1702	1702	1702	1702	1711	1711	1711	1711
J	1245	1245	1245	1245	1632	1632	1632	1632
K	137	137	137	137	203	203	203	203
L	273	273	273	273	406	406	406	406
M	267	267	267	267	254	254	254	254
N	914	914	914	914	1321	1321	1321	1321
P	1448	1448	1448	1448	1829	1829	1829	1829

Rigging and Service Clearances

Service clearance is required on all sides of the machine. Pay particular attention to the control panel door clearance and the clearance at one end for tube service.

Figure DW-4 and Table DW-6 illustrate the recommended clearances for normal service and tube replacement. When sufficient overhead clearance exists, we recommend placing a 6-8 inch (150-200 mm) extension underneath the machine legs for additional access under the chiller.

Overhead lift is the recommended method when moving a machine. Before lifting the machine, determine the approximate location of the center of gravity.

Dimensions and Weights

Cold Insulation

Low Temperature Insulation (Cold Insulation Type)

Cold insulation can be ordered as a factory-installed option. The quantity and the areas to be covered are illustrated in Table DW-7 and Figure DW-5.

Figure DW-5. Cold insulation

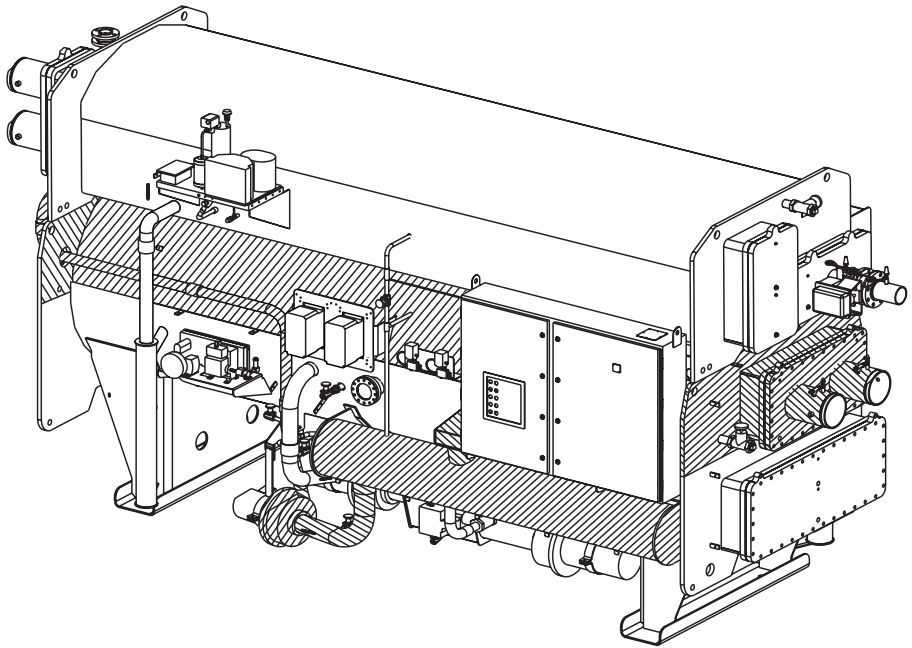

Table DW-7. Cold insulation area and length

English Units						
Refrigerant Storage Tank Circuit	Evaporator Shell	Tubesheets & Water Boxes	2" Pipe	4.50" Pipe		
500T	45.01 sq. ft	500T 97.65 sq. ft	500T-800T 11.19 LN FT	500T-800T 2.625 LN FT		
600T	55.53 sq. ft	600T 115.87 sq. ft				
700T	66.04 sq. ft	700T 134.12 sq. ft				
800T	76.55 sq. ft	800T 152.32 sq. ft				
Refrigerant Storage Tank Circuit	Evaporator Shell	Tubesheets & Water Boxes	3.50" Pipe	4.00" Pipe	4.50" Pipe	
975T-1350T	64.876 sq. ft	975T-1350T 164.32 sq. ft	975T-1350T 5.97 LN FT	975T-1350T 2.92 LN FT	975T-1350T 2.24 LN FT	
		1100T 171.58 sq. ft				
		1225T 188.91 sq. ft				
		1350T 206.26 sq. ft				
SI Units						
Refrigerant Storage Tank Circuit	Evaporator Shell	Tubesheets & Water Boxes	2" Pipe	4.50" Pipe		
500T	4.18 sq. m	500T 9.07 sq. m	500T-800T 3411 mm	500T-800T 800 mm		
600T	5.16 sq. m.	600T 10.76 sq. m.				
700T	6.14 sq. m.	700T 12.46 sq. m.				
800T	7.11 sq. m.	800T 14.15 sq. m.				
Refrigerant Storage Tank Circuit	Evaporator Shell	Tubesheets & Water Boxes	3.50" Pipe	4.00" Pipe	4.50" Pipe	
975T-1350T	6.03 sq. m	975T 14.33 sq. m	975T-1350T 1820 mm	975T-1350T 890 mm	975T-1350T 683 mm	
		1100T 15.94 sq. m.				
		1225T 17.55 sq. m.				
		1350T 19.16 sq. m.				

Dimensions and Weights

Weights and Connection Sizes

Table DW-8. Weights and connection sizes

English Units						
Model	Weights		Connection Sizes		Unit Charging	
	Shipping [lbm]	Operating [lbm]	Evap [in]	Cond/Abs [in]	54.7% Brine [lbm]	Refrigerant [gal]
ABSD 500	22900	31800	8	8	3620	150
ABSD 600	25500	35700	8	8	4040	190
ABSD 700	28000	40100	10	10	4620	230
ABSD 800	30600	44200	10	10	5140	270
ABSD 975	36305	49910	12	12	5080	162
ABSD 1100	38769	53487	12	12	5499	179
ABSD 1225	41450	57262	12	12	5880	197
ABSD 1350	43941	60776	12	12	6215	213

SI Units						
Model	Weights		Connection Sizes		Unit Charging	
	Shipping [kg]	Operating [kg]	Evap [mm]	Cond/Abs [mm]	54.7% Brine [kg]	Refrigerant [l]
ABSD 500	10400	14400	203	203	1642	568
ABSD 600	11500	16200	203	203	1833	719
ABSD 700	12700	18200	254	254	2096	871
ABSD 800	13900	20100	254	254	2331	1022
ABSD 975	16468	22639	305	305	2304	613
ABSD 1100	17585	24262	305	305	2494	679
ABSD 1225	18802	25974	305	305	2667	745
ABSD 1350	19931	27568	305	305	2819	805

Job Site Connections

Steam Supply and Condensate Piping

Steam Supply

Figure JC-1 illustrates a typical steam-supply piping illustration that includes the appropriate hardware.

The steam supply piping should be designed in accordance with good design practice, providing strainers, unions and gate valves for ease of operation and maintenance. A properly sized steam-modulating valve, based on design flow and pressure drop requirements, is provided by The Trane Company.

A hand valve in the steam supply piping is recommended when the machine will be out of operation for an extended period. The modulating steam valve may experience a small amount of leakage during shutdown. This leakage may result in heating of the equipment room unless the machine is properly isolated with a hand valve.

In all applications, it is recommended that the steam supply pressure to the control valve inlet not exceed design to ensure that the valve closes properly. If steam supply pressures exceed design, a pressure reducing station should be used to control the steam pressure to the valve.

The unit control has adjustable features that minimize steam draw on start-up. The adjustable steam-control feature allows the user to adapt the machine to the available steam source capability.

Figure JC-1. Typical steam supply piping

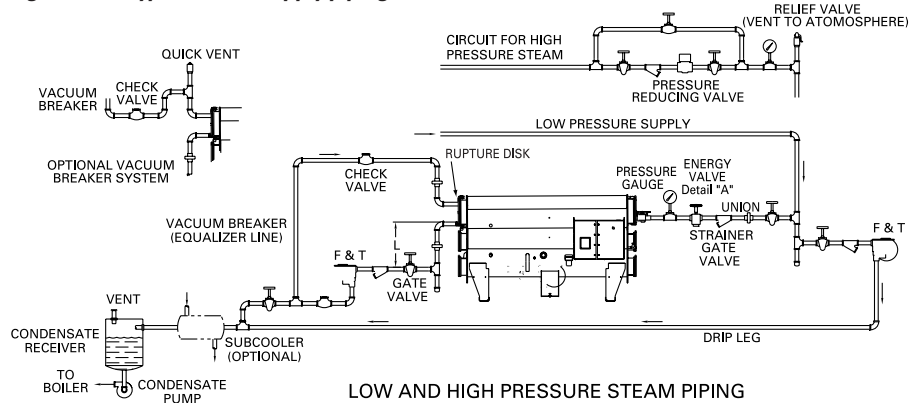

Table JC-1. Steam supply and condensate return piping responsibilities

Item	Material Provided By		Installed By	
	Trane	Other	Trane	Other
Energy Valve	X		X	
T-Type Strainer, Flanged connections, gate valve, drip leg w/dirt pocket, float and thermostatic trap, pressure gauge vent and valve, pressure reducing valve, pressure gauge, relief valve check valve, connecting piping.		X		X
Rupture Disk Assembly	X		X	
Rupture Disk Piping		X		X

Job Site Connections

Steam Supply and Condensate Piping

Condensate Handling

Figure JC-1 illustrates a typical condensate system consisting of steam traps, condensate receivers and condensate pumps. Such systems provide the most economical method for returning condensate to a boiler. Properly-sized float and thermostatic traps are required for proper operation. The use of bucket traps is not recommended.

Trane absorption machines use steam-throttling control. A maximum of three percent of the condensate may flash to a vented receiver at full load. This flashing decreases as the load decreases, and is virtually nonexistent below 70 percent load. When the machine is operating at less than 70 percent load, the pressure in the generator tube bundle may be below atmospheric pressure. The temperature of the condensate leaving the machine under these conditions is less than 212°F [100°C], so flashing does not occur.

A subcooler may be installed ahead of the receiver to cool the condensate to a temperature below the saturation temperature at atmospheric pressure, thus eliminating flashing entirely. It is recommended that a cooling medium, such as boiler feed water, be used to keep this energy within the system. The pressure drop through the subcooler should be minimized.

Figure JC-1 indicates an equalizer line installed to avoid condensate backup in the machine. The swing check opens if a vacuum develops within the tube bundle under part-load operation.

This prevents development of a lower pressure in the concentrator than at the outlet of the trap.

Packaged Condensate Systems

Several manufacturers have available packaged condensate-pump systems, designed for various condensate temperatures. A decision regarding the use of these systems with a Trane absorption machine should be based on a thorough economic analysis of the particular installation. The following factors should be considered:

1. Condensate may flash in the receiver less than 20 percent of the total operating time in a typical installation. The amount of condensate that may flash varies from a maximum of three percent at full load, to none at less than 70 percent load. A subcooler can be used to eliminate the small amount of flashing that may occur when the machine is operating under heavy load.
2. The condensate system must prevent condensate from backing up into the machine at part load when the pressure in the generator tube bundle is below atmospheric pressure.
3. The condensate system must not draw supply steam through the machine. This reduces the machine efficiency and may offset any potential energy savings that might otherwise be realized by the use of the condensate return system. Also, reduced tube life would result due to erosion.

If the decision is made to use a packaged condensate-pump system, follow the manufacturer's recommendations regarding its application.

Job Site Connections

Hot Water Piping

Hot Water Piping

The hot water system must be designed such that it will avoid fluctuations in the pressure differences across the control valve. Trane absorption chillers for use with hot water may be used at an entering hot-water temperature of 270°F [132°C] or below. Piping for a typical hot water installation using a temperature of 270°F [132°C] or less is shown in Figure JC-2. In this arrangement, a three-way energy valve is used to control capacity by varying the quantity of hot water flowing through the chiller, while maintaining a constant supply and return flow rate. As shown in Figure JC-3, a two-way energy valve can also be used where the return and supply flow rates can vary. The generator design is rated to 150 psig [10.3 bars] with a 400 psig [27.6 bars] optional design available.

When the supply-water temperature exceeds 270°F [132°C], a separate circulating pump is recommended in a run-around loop as shown in Figure JC-4. The hot water for the absorption machine should be taken from a header installed between the hot-water supply and return mains. The flow of hot water through the machine is held constant, but the temperature of the circulating water is varied to meet load requirements by modulating the amount of high-temperature supply water added to the loop. This is done by installing a two-way modulating valve at the loop outlet. The valve responds to the chilled-water temperatures, but limits the water temperature entering the machine to a maximum of 270°F [132°C].

Hot Water Valves

Trane provides hot-water temperature-control valves with the machine for installation by the contractor at the job site. These valves are selected by The Trane company based on data provided by the contractor (*i.e. water flow to be used and the design pressure-drop across the valve.)

It is desirable to use the smallest valve, with the highest pressure drop, appropriate to the design water flow and allowable pressure drop in the system. The smaller the valve, the better the control.

Figure JC-2. Hot water supply piping – 270°F and below with 3-way energy valve

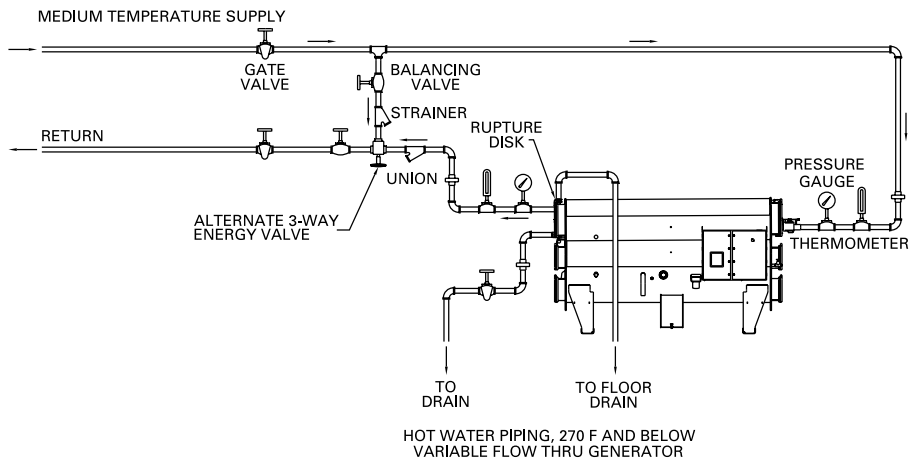
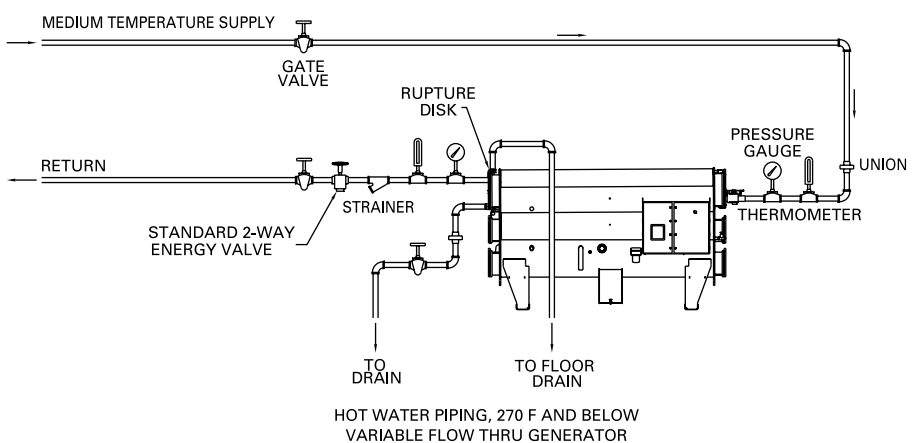

Figure JC-3. Hot water supply piping – 270°F and below with 2-way energy valve



Job Site Connections

Hot Water Piping

Figure JC-4. Hot water supply temperature piping above 270°F

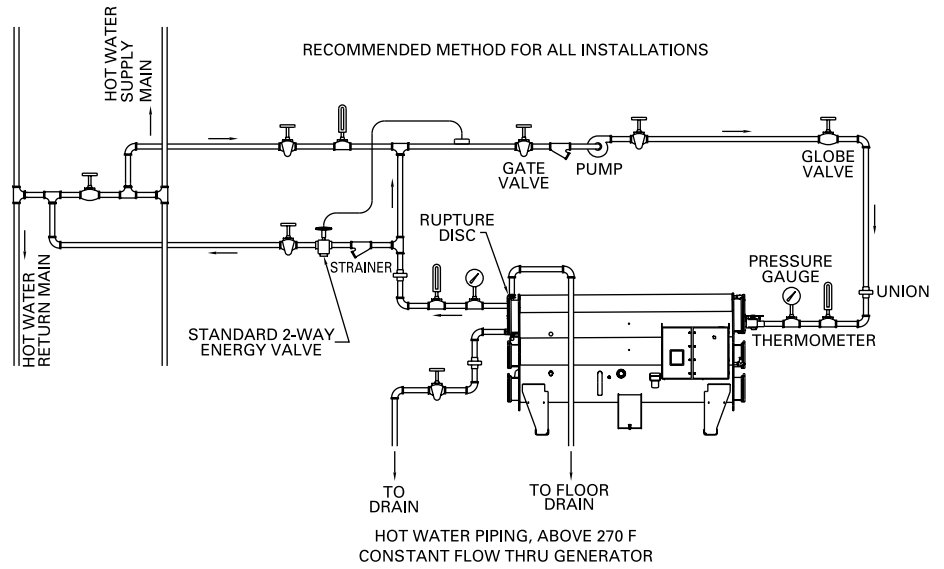

Table JC-2. Hot water supply piping responsibilities

Item	Material Provided By		Installed By	
	Trane	Other	Trane	Other
Energy Valve (2-Way/3-Way)	X			X
Gate valve, balance valve, Y-type strainer w/valve, bypass circuit, check valve, thermometer, pressure gauge, vent shutoff valve, union or flanged connection circulating pump		X		X
Rupture Disk Assembly	X		X	
Rupture Disk Piping		X		X

Job Site Connections

Cooling Water Piping

Cooling Water Piping

The cooling water piping design for the Horizon series of absorption chillers differs from conventional reciprocating or centrifugal systems, in that cooling water passes through the absorber section of the machine prior to entering the condenser.

The Horizon Single Stage absorption chiller is designed to start and operate with cooling-water temperatures as low as 55°F [12.8°C]. In typical applications, the machine is selected on the basis of the cooling-water temperature that will be available at full-load and at the design outside conditions. In air conditioning applications utilizing a cooling tower, this is usually 85°F [29.4°C].

With a cooling tower sized at design conditions, the temperature of the cooling-water supply to the unit will decrease with any decrease in cooling load or outside wet-bulb temperature. The lower cooling-water temperature would normally tend to increase the capacity potential of the unit. In the Trane design, the UCP2 adaptive controls will limit the energy input of the machine based on the entering cooling water temperature, thereby preventing overfiring of the machine.

In typical air-conditioning applications, precise cooling-water temperature control is not required. In process applications, however, where extremely close control of leaving chilled-water is required, it is recommended that a tower valve be used to maintain cooling-water temperature at a specified temperature. Constant cooling-water temperature allows the unit control valve to more precisely control leaving chilled-water temperature. Also, in applications where well water or other cooling water will be available at a temperature below 65°F [18.3°C], a control valve is recommended to maintain the temperature at 65°F [18.3°C] or above. Changes in condenser water temperature should not exceed 1°F per minute in the range of 75°F to 95°F [23.9 to 35°C].

Figure JC-5 illustrates a typical air-conditioning installation without a cooling-tower control valve. Figure JC-6 illustrates typical cooling-water piping in applications where a three-way valve may be required. Figure JC-7 illustrates typical cooling-water piping utilizing well or river water.

Figure JC-5. Cooling-water piping with cooling tower

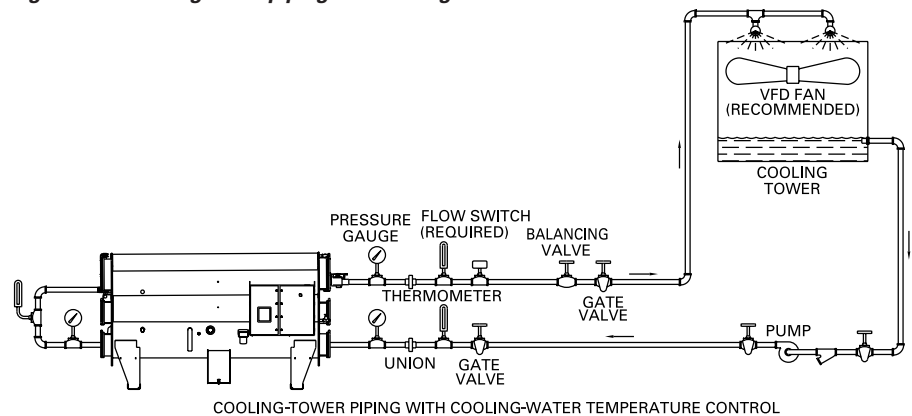
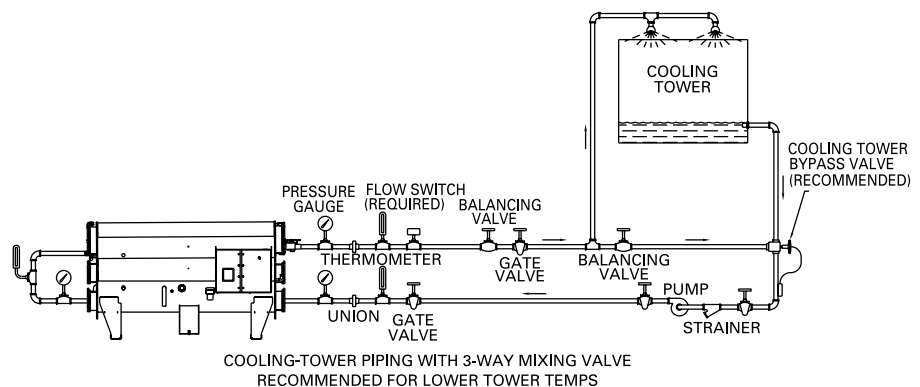

Figure JC-6. Cooling-water piping, three-way mixing valve



Job Site Connections

Cooling Water Piping

Figure JC-7. Cooling-water piping with well or river water

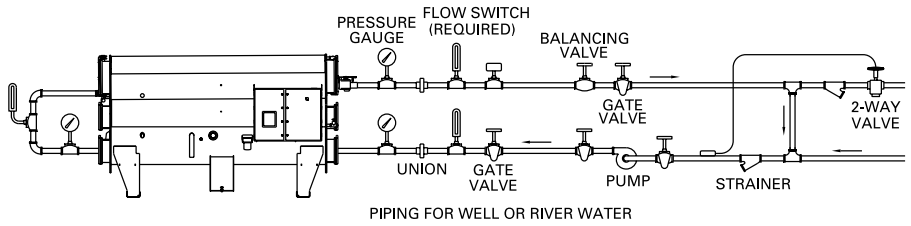

Table JC-3. Condenser/absorber piping responsibility

Item	Trane	Material Provided By		Installed By	
		Other	Trane	Other	Other
Crossover Pipe	(factory installed option) X or	X	(factory installed option) X or		
Flow Switch	(optional) X or	X			X
Balancing valve, gate valve, thermometer (optional), pressure gauge vent and shutoff valve, Victaulic or flange connection, pipe stub, strainer, pump.		X			X



Mechanical Specifications

General

The unit is a complete, single-effect steam- or hot-water-fired absorption chiller package, built in an ISO 9001 environment. The chiller consists of generator/condenser section, evaporator/absorber section, controls, pumps, heat exchanger, and energy control valve. All units are of hermetic design, factory-assembled and leak-tested prior to shipment. Units can be separated and shipped disassembled for rigging purposes. Unit controls are factory mounted and wired, including microelectronic control panel, sensors and purge system. An energy valve can be factory mounted and wired as an option on steam-fired units. The unit is painted prior to shipping with two coats of a water-base air-dry primer. Standard method of shipment is by truck.

Generator/Condenser-Evaporator/Absorber

The shell material is carbon steel. The standard generator tube material is cupro-nickel, the evaporator is copper, absorber is cupro-nickel or copper and the condenser is copper. Tubes are mechanically rolled into the tube sheets and are replaceable from either end. The condenser, evaporator and absorber tube supports are fixed. The generator consists of fixed and floating tube supports to allow for even tube expansion. Solution spray systems are replaceable from one end of the unit without sacrificing the hermetic integrity of the unit.

Design working pressure for the water boxes is 150 psig [10.3 bars]. All tube bundles are tested at 150 percent of design working pressure. All water boxes have gasketed, removable covers for access. Optional marine-type water boxes can be provided on the condenser and absorber. Water connections are provided with either victaulic or raised-face flanged connections.

Heat Exchangers

A brazed-plate solution heat exchanger is provided to reduce energy use and improve unit performance. Heat exchanger surfaces are 300 series stainless steel.

Pumps

Solution and refrigerant are circulated by means of three hermetic, single-stage centrifugal pumps. The pump impellers are cast iron, with a steel shaft supported by two tapered carbon bearings. The bearings are lubricated and the motor is cooled via the pumped fluid. Adjustable-frequency drives are provided on the generator pump and absorber pump to provide solution flow control.

Automatic Purge System

The purge system utilizes an eductor for moving noncondensables to the condenser, Purifier™ Purge to collect the noncondensables in an external storage tank, and a vacuum pump for removal of the noncondensables. The purge operates automatically to remove noncondensables from the unit during periods of chiller operation and shutdown. Logging of purge information is provided via the unit control panel.

Generator

The shell is carbon steel. Tube sheets are steel and standard generator tubes are constructed of copper nickel. The generator has fixed and floating tube supports to allow for even tube expansion. The steam side of the generator is designed and stamped for 50 psi ASME construction. For hot water as the energy source, the generator is ASME designed and stamped for 150 or 400 psi [10.3 or 27.6 bars]. The generator/condenser includes a rupture disk, which is sized to meet ANSI/ASHRAE B 15.

Optional Lithium Bromide Filter

The filter system consists of the filter assembly and the associated piping and filter-isolation valves needed for operation and maintenance. The main filter body is stainless steel with a removable, cleanable, stainless steel internal 150-micron element. The filter isolation valves allow service of the filter assembly without disturbing the operation of the rest of the machine.

Control Panel

The UCP2™ is a microprocessor-based chiller control system that provides complete stand-alone operation. It is a factory-mounted package, including a full complement of controls to safely and efficiently operate the absorption liquid chiller. The UCP2™ provides:

- Chilled-water temperature control
- Concentration control

System Features and Functions

- User interface with a 40-character, 2-line display capable of displaying 7 languages and SI or English units, and a 16 key keypad
- Passwords for protection of unit setup and configuration
- Chilled-water pump control
- Absorber/condenser pump control
- Automatic and manual control of solution and refrigerant pumps
- Economical solution-flow control of the low-temperature solution pump and absorber pump via an adjustable-frequency drive
- Anti-crystallization through dilution control
- Automatic and manual purge system
- Chilled-water reset
- Two-way valve assembly for hot-water flow control or steam flow control
- Concentration control
- Steam adaptive flow control

Mechanical Specifications

Adaptive Limits

- Evaporator-water temperature limit
- Low absorber/condenser limit
- Soft-loading control

System Protection

- Evaporator freeze protection
- Chilled-water flow confirmation
- Cooling-water flow confirmation
- Emergency stop/shutdown
- Under/over voltage detection

Monitor and Displays

- Chilled-water temperature entering and leaving
- Absorber/condenser water temperature entering and leaving
- Solution concentrations
- Solution temperatures
- Total pump current
- Unit voltage
- Chiller run-time and starts
- Purge operation and run time
- Alarm light
- Diagnostic messages
- Help screens
- Evaporator-water flow (option)
- Cooling-water flow (option)

Interfaces To UCP2™

- External machine manual-reset alarm indication output
- External machine auto-reset warning indication output
- External limit warning-indication output
- Maximum capacity indication output
- External auto-stop/emergency shutdown
- Interface to Tracer Summit™
- External chilled-water setpoint
- Tracer™ controlled relay
- Printer interface

Contractor Responsibilities

1. Install the unit on a level surface. Neoprene isolation pads supplied by the manufacturer shall be placed under the unit.
2. Connect the unit control panel to all operating external safety and auxiliary control devices.
3. Insure that piping adjacent to the machine does not restrict removal of headers for inspection, cleaning and removing tubes.
4. Provide gauge cocks and optional thermometer wells for temperature and pressure readings at the inlet and outlet of the evaporator, at the inlet and outlet of the absorber, and at the outlet of the condenser.
5. Provide balancing valves in all external water circuits to allow balance and trim of the system.
6. Provide and install strainers ahead of all pumps and automatic modulating valves to insure proper pump and valve operation.
7. Insulate the chilled-water headers and other portions of the unit, as pointed out in the manufacturer's installation literature, to prevent condensation on cold surfaces.
8. Provide and install a flow switch in the chilled-water circuit, and interlock it with the starting control circuit of the unit. Proof of flow is required prior to permitting unit operation. Provide and install a flow switch in the tower-water circuit, which shall be interlocked with the starting control circuit of the unit such that proof of flow is required to prevent machine damage.
9. Provide necessary distilled or demineralized water for refrigerant charge and trim charge.
10. Provide labor to charge the machine with lithium bromide solution and refrigerant water, and assist in machine starting and calibration under supervision of the manufacturer's representative.

11. Provide an appropriately-sized vacuum pump and personnel to evacuate the unit prior to charging (if required).
12. Field assemble machines (if required) and leak test in accordance with instructions in the manufacturer's installation bulletin.
13. Connect the rupture disc to an appropriate floor drain or retention chamber. The vent piping shall be supported and connected by a flexible connector to prevent stress at the connection.
14. Install any control components provided by the manufacturer for installation external to the machine.
15. Furnish and install, external to the unit control panel, a separately-fused disconnect switch, if not provided.
16. Install required power supply wiring to the control panel. Use copper wire only.

Insulation Required

Insulation is required on cold areas to prevent sweating. Insulation is available as a factory provided, factory installed option.

Insulation for cold insulation area should be ¾-inch [19 mm] Armaflex or equivalent, and should be applied to evaporator waterboxes, refrigerant storage tank, refrigerant pump and refrigerant piping.

Cold insulation area on ABSD requires _____ per unit.

Cold insulation area for pipes on requires _____ linear ft. of pipe insulation.



Standard/Non-Standard/Design Special Options

Standard Features

- Victaulic water connections
- Variable-speed drives on solution pumps
- 50,000 hours design life solution pumps
- Corrosion resistant alloy tubes
 - Generator – .028 wall, 90/10 cupro-nickel
 - Evaporator – .025 copper
 - Absorber 500-800 tonnages – .022" wall 95/5 cupro-nickel
 - 975-1350 tonnages .028" wall copper
 - Condenser – .028" wall copper
- Factory-mounted and-tested microprocessor controls
- 150 psig [10.3 bar] water boxes
- Environmentally friendly inhibitor
- Fixed and floating tube supports which allow for expansion of tubes without problems of high stress
- Designed, manufactured and tested for superior hermetic integrity
- Fully automatic purge

Options

- Marine water boxes on the condenser and absorber sections
- Factory installed cooling-water crossover pipe
- Industrial duty factory mounted energy valve
- 150 psig [10.3 bar] raised face flanges for the evaporator, condenser and absorber water connections
- Major component disassembly in two pieces for installations that can benefit from the handling of smaller components.
- Lithium bromide filter
- Stainless steel evaporator pan

Design Special Options

In addition to the options already available, Trane's design department is able to supply custom features for many special requirements.

Examples are:

- Factory provided, factory installed cold insulation
- Heavy wall tubes
- 90/10 CuNi, stainless steel and titanium tubes
- 300 psig [20.7 bar] water boxes
- NEMA 4 and 4X for additional chiller protection against outdoor elements or water impingement from various directions
- Alternate pass arrangements
- Marine-style evaporator water boxes
- Epoxy paint system for added protection against outdoor elements or corrosive environments such as chemical plants or salt water locations
- Custom color paints
- Sacrificial anodes for use where corrosive water is present
- Gantries for "swing out" water box covers for easy tube-cleaning capability
- Custom control configurations
- Specials for international code compliance
- Special packaging requirements
- Options for using non-standard heat sources
- Hinged water box covers



Standard Conversion Table

To Convert From:	To:	Multiply By:	To Convert From:	To:	Multiply By:
Length			Energy and Power and Capacity		
Feet (ft)	meters (m)	0.30481	British Thermal Units (BTUH)	Kilowatt (kW)	0.000293
Inches (In)	millimeters (mm)	25.4	British Thermal Units (BTU)	KCalorie (Kcal)	0.252
Area			Tons (refrig. effect)	Kilowatt (refrig. effect)	3.516
Square Feet (ft ²)	square meters (m ²)	0.093	Tons (refrig. effect)	Kilocalories per hour (Kcal/hr)	3024
Square Inches (In ²)	square millimeters (mm ²)	645.2	Horsepower	Kilowatt (kW)	0.7457
Volume			Pressure		
Cubic Feet (ft ³)	Cubic meters (m ³)	0.0283	Feet of water (ftH ₂ O)	Pascals (PA)	2990
Cubic Inches (In ³)	Cubic mm (mm ³)	16387	Inches of water (inH ₂ O)	Pascals (PA)	249
Gallons (gal)	litres (l)	3.785	Pounds per square inch (PSI)	Pascals (PA)	6895
Gallons (gal)	cubic meters (m ³)	0.003785	PSI	Bar or KG/CM ²	6.895 x 10 ⁻²
Flow			Weight		
Cubic feet/min (cfm)	cubic meters/second (m ³ /s)	0.000472	Ounces (oz)	Kilograms (kg)	0.02835
Cubic Feet/min (cfm)	cubic meters/hr (m ³ /hr)	1.69884	Pounds (lbs)	Kilograms (Kg)	0.4536
Gallons/minute (GPM)	cubic meters/hr (m ³ /hr)	0.2271	Fouling factors for heat exchangers		
Gallons/minute (GPM)	litres/second (l/s)	0.06308	0.00075 ft ² °F hr/BTU	= 0.132 m ² °K/kW	
Velocity			0.00025 ft ² °F hr/BTU	= 0.044 m ² °K/kW	
Feet per minute (ft/m)	meters per second (m/s)	0.00508			
Feet per second (ft/s)	meters per second (m/s)	0.3048			

Temperature – Centigrade (°C) Versus Fahrenheit (°F)

Note: The center columns of numbers, referred to as BASE TEMP, is the temperature in either degrees Fahrenheit (°F) or Centigrade (°C), whichever is desired to convert into the other. If degrees Centigrade is given, read degrees Fahrenheit to the right. If degrees Fahrenheit is given, read degrees Centigrade to the left.

Temperature			Temperature			Temperature			Temperature			Temperature		
°C	C or F	°F	°C	C or F	°F	°C	C or F	°F	°C	C or F	°F	°C	C or F	°F
-40.0	-40	-40.0	-15.0	+5	+41.0	+10.0	+50	+122.0	+35.0	+95	+203.0	+60.0	+140	+284.0
-39.4	-39	-38.2	-14.4	+6	+42.8	+10.6	+51	+123.8	+35.6	+96	+204.8	+60.6	+141	+285.8
-38.9	-38	-36.4	-13.9	+7	+44.6	+11.1	+52	+125.6	+36.1	+97	+206.6	+61.1	+142	+287.6
-38.3	-37	-34.6	-13.3	+8	+46.4	+11.7	+53	+127.4	+36.7	+98	+208.4	+61.7	+143	+289.4
-37.8	-36	-32.8	-12.8	+9	+48.2	+12.2	+54	+129.2	+37.2	+99	+210.2	+62.2	+144	+291.2
-37.2	-35	-31.0	-12.2	+10	+50.0	+12.8	+55	+131.0	+37.8	+100	+212.0	+62.8	+145	+293.0
-36.7	-34	-29.2	-11.7	+11	+51.8	+13.3	+56	+132.8	+38.3	+101	+213.8	+63.3	+146	+294.8
-36.1	-33	-27.4	-11.1	+12	+53.6	+13.9	+57	+134.6	+38.9	+102	+215.6	+63.9	+147	+296.6
-35.6	-32	-25.6	-10.6	+13	+55.4	+14.4	+58	+136.4	+39.4	+103	+217.4	+64.4	+148	+298.4
-35.0	-31	-23.8	-10.0	+14	+57.2	+15.0	+59	+138.2	+40.0	+104	+219.2	+65.0	+149	+300.2
-34.4	-30	-22.0	-9.4	+15	+59.0	+15.6	+60	+140.0	+40.6	+105	+221.0	+65.6	+150	+302.0
-33.9	-29	-20.2	-8.9	+16	+60.8	+16.1	+61	+141.8	+41.1	+106	+222.8	+66.1	+151	+303.8
-33.3	-28	-18.4	-8.3	+17	+62.6	+16.7	+62	+143.6	+41.7	+107	+224.6	+66.7	+152	+305.6
-32.8	-27	-16.6	-7.8	+18	+64.4	+17.2	+63	+145.4	+42.2	+108	+226.4	+67.2	+153	+307.4
-32.2	-26	-14.8	-7.2	+19	+66.2	+17.8	+64	+147.2	+42.8	+109	+228.2	+67.8	+154	+309.2
-31.7	-25	-13.0	-6.7	+20	+68.0	+18.3	+65	+149.0	+43.3	+110	+230.0	+68.3	+155	+311.0
-31.1	-24	-11.2	-6.1	+21	+69.8	+18.9	+66	+150.8	+43.9	+111	+231.8	+68.9	+156	+312.8
-30.6	-23	-9.4	-5.5	+22	+71.6	+19.4	+67	+152.6	+44.4	+112	+233.6	+69.4	+157	+314.6
-30.0	-22	-7.6	-5.0	+23	+73.4	+20.0	+68	+154.4	+45.0	+113	+235.4	+70.0	+158	+316.4
-29.4	-21	-5.8	-4.4	+24	+75.2	+20.6	+69	+156.2	+45.6	+114	+237.2	+70.6	+159	+318.2
-28.9	-20	-4.0	-3.9	+25	+77.0	+21.1	+70	+158.0	+46.1	+115	+239.0	+71.1	+160	+320.0
-28.3	-19	-2.2	-3.3	+26	+78.8	+21.7	+71	+159.8	+46.7	+116	+240.8	+71.7	+161	+321.8
-27.8	-18	-0.4	-2.8	+27	+80.6	+22.2	+72	+161.6	+47.2	+117	+242.6	+72.2	+162	+323.6
-27.2	-17	+1.4	-2.2	+28	+82.4	+22.8	+73	+163.4	+47.8	+118	+244.4	+72.8	+163	+325.4
-26.7	-16	+3.2	-1.7	+29	+84.2	+23.3	+74	+165.2	+48.3	+119	+246.2	+73.3	+164	+327.2
-26.1	-15	+5.0	-1.1	+30	+86.0	+23.9	+75	+167.0	+48.9	+120	+248.0	+73.9	+165	+329.0
-25.6	-14	+6.8	-0.6	+31	+87.8	+24.4	+76	+168.8	+49.4	+121	+249.8	+74.4	+166	+330.8
-25.0	-13	+8.6	0.0	+32	+89.6	+25.0	+77	+170.6	+50.0	+122	+251.6	+75.0	+167	+332.6
-24.4	-12	+10.4	+0.6	+33	+91.4	+25.6	+78	+172.4	+50.6	+123	+253.4	+75.6	+168	+334.4
-23.9	-11	+12.2	+1.1	+34	+93.2	+26.1	+79	+174.2	+51.1	+124	+255.2	+76.1	+169	+336.2
-23.3	-10	+14.0	+1.7	+35	+95.0	+26.7	+80	+176.0	+51.7	+125	+257.0	+76.7	+170	+338.0
-22.8	-9	+15.8	+2.2	+36	+96.8	+27.2	+81	+177.8	+52.2	+126	+258.8	+77.2	+171	+339.8
-22.2	-8	+17.6	+2.8	+37	+98.6	+27.8	+82	+179.6	+52.8	+127	+260.6	+77.8	+172	+341.6
-21.7	-7	+19.4	+3.3	+38	+100.4	+28.3	+83	+181.4	+53.3	+128	+262.4	+78.3	+173	+343.4
-21.1	-6	+21.2	+3.9	+39	+102.2	+28.9	+84	+183.2	+53.9	+129	+264.2	+78.9	+174	+345.2
-20.6	-5	+23.0	+4.4	+40	+104.0	+29.4	+85	+185.0	+54.4	+130	+266.0	+79.4	+175	+347.0
-20.0	-4	+24.8	+5.0	+41	+105.8	+30.0	+86	+186.8	+55.0	+131	+267.8	+80.0	+176	+348.8
-19.4	-3	+26.6	+5.5	+42	+107.6	+30.6	+87	+188.6	+55.6	+132	+269.6	+80.6	+177	+350.6
-18.9	-2	+28.4	+6.1	+43	+109.4	+31.1	+88	+190.4	+56.1	+133	+271.4	+81.1	+178	+352.4
-18.3	-1	+30.2	+6.7	+44	+111.2	+31.7	+89	+192.2	+56.7	+134	+273.2	+81.7	+179	+354.2
-17.8	0	+32.0	+7.2	+45	+113.0	+32.2	+90	+194.0	+57.2	+135	+275.0	+82.2	+180	+356.0
-17.2	+1	+33.8	+7.8	+46	+114.8	+32.8	+91	+195.8	+57.8	+136	+276.8	+82.8	+181	+357.8
-16.7	+2	+35.6	+8.3	+47	+116.6	+33.3	+92	+197.6	+58.3	+137	+278.6	+83.3	+182	+359.6
-16.1	+3	+37.4	+8.9	+48	+118.4	+33.9	+93	+199.4	+58.9	+138	+280.4	+83.9	+183	+361.4
-15.6	+4	+39.2	+9.4	+49	+120.2	+34.4	+94	+201.2	+59.4	+139	+282.2	+84.4	+184	+363.2

FOR INTERPOLATION IN THE ABOVE TABLE USE:

BASE TEMPERATURE (°F or °C)	1	2	3	4	5	6	7	8	9	10
DEGREES CENTIGRADE:	0.56	1.11	1.67	2.22	2.78	3.33	3.89	4.44	5.00	5.56
DEGREES FAHRENHEIT:	1.8	3.6	5.4	7.2	9.0	10.8	12.6	14.4	16.2	18.0



Trane
A business of American Standard Companies
www.trane.com

Literature Order Number	ABS-PRC001-EN
File Number	PL-RF-ABS-000-PRC001-EN-0603
Supersedes	ABS-PRC001-EN 0501
Stocking Location	Inland

For more information contact your local sales office
or e-mail us at comfort@trane.com

Trane has a policy of continuous product and product data improvement and reserves the right to change
design and specifications without notice.