

ACH 502

Installation & Start-up Manual

ACH 502/504
Adjustable Frequency
AC Drives 60 to 400 HP, Series B

ACH 502-04F
EFFECTIVE 8/31/95
SUPERSEDES 9/1/94

ABB Drives



ACH 502/504
Adjustable Frequency AC Drives
60 to 400 HP, Series B

Installation & Start-up Manual

ACH 502-04F

EFFECTIVE: 1995-08-31:
SUPERSEDES: 1994-09-01:

Safety Instructions

General Safety Instructions

Warnings in this manual appear in either of two ways:

- *Dangerous voltage warnings*, preceded by a Dangerous Voltage symbol, indicate the presence of voltages which may cause death or serious injury. These warnings describe procedures to avoid death or serious injury.
- *General warnings*, preceded by a General Warning symbol, indicate situations or conditions which may cause death or serious injury. These warnings describe procedures to avoid death or serious injury.

CAUTIONS inform you of situations or conditions which will damage machinery or cause additional motor-operation down-time if you do not take suggested steps to correct or address such situations or conditions.

Note: Notes provide you with additional and useful information. Although less urgent than cautions and warnings, notes are important and should not be ignored.

Warning Symbols

For your own safety please pay special attention to instructions containing these symbols:



This warning symbol indicates the presence of dangerous voltage. This symbol informs you of high voltage conditions, situations, and locations that may cause death or serious injury if you do not follow precautions and proper steps.



This warning symbol indicates a general warning.



This warning symbol indicates an electrostatic discharge hazard.

**Warnings, Cautions,
and Notes**



WARNING! Your drive contains dangerous voltages when connected to the line power. Always check that the ACH 502/504 is safe, after disconnecting the power, by measuring the DC bus voltage and line input voltage. Failure to check voltages could cause death or serious injury. Only a qualified electrician should carry out the electrical installation.

Note that the Motor Control Card of the ACH 502/504 is at DC bus voltage potential.

The DC bus capacitors contain dangerous DC voltage levels ($1.35 \times V_{IN}$). After disconnecting the supply, wait at least five minutes after the display readout on the control panel has disappeared before taking any measurements.

Dangerous external control voltages may be present on the relay outputs of the Control Interface Card and Option Cards.



CAUTION: Electrostatic Discharge (ESD) can damage electronic circuits. Do not handle any components without following the proper ESD precautions.

Table of Contents

Chapter 1 – Introduction

- How To Use This Manual 1-1
- Intended Audience 1-2
- Conventions Used In This Manual 1-2
 - Control Panel Display 1-2
 - Control Panel Keys 1-2
 - Main 1-2
 - Group 1-2
 - Parameter 1-2
 - Press 1-2
 - Terminal Block 1-3
- Warranty and Liability Information 1-3
- Related Publications 1-3

Chapter 2 – Overview of the ACH 502/504

- Nameplate Identification 2-1
 - Types and Ratings of the ACH 502/504 2-3
 - ACH 502 Control Identification 2-3
- General Information About Your ACH 502/504 2-5
 - Functional Description 2-5
- Control Panel Operation 2-7
 - Control Panel Display 2-7
 - Control Panel Keys 2-8
- Application Macros Overview 2-10
- Hardware Description 2-10
 - Inverter Module 2-10
 - Features and Functions 2-13
- Custom Options 2-16
 - Control Options 2-16
 - Input Options 2-16
 - Bypass Options 2-17
 - Meters 2-23

Chapter 3 – ACH 502 Installation Instructions

- Grounding and Ground Faults 3-1
- Pre-Installation Planning 3-1
 - Environment 3-1
 - Mounting Area 3-2
 - Installation Site Power 3-2
 - Conduit Size 3-3
 - Power Wiring 3-4
 - Output Power Wiring 3-5

Table of Contents

Power Connections 3-6
 Input Wiring 3-6
 Output Wiring 3-7
Control Connections 3-8
 Available Control Locations 3-8
 Terminal Block Connections 3-9

Chapter 4 – ACH 504 Installation Instructions

Pre-Installation Planning 4-1
Environment 4-7
 Inverter Modules 4-7
 Control Unit 4-8
Power Wiring 4-9
 Input and Output Power Wiring 4-9
 Checking the Motor Insulation 4-13
Control Connections 4-13
 Available Control Locations 4-13
 X50 4-14
Control Interface Card Connections 4-16

Chapter 5 – Start-up Procedure

Safety Precautions 5-1
Installation Inspection 5-2
Start-up Data Parameters 5-3
Keypad Control Tests 5-4
 Motor Disconnected from the ACH 502 5-4
 Motor Connected to the ACH 502 5-5
 Keypad Control vs. External Control 5-6
Default Drive Parameters 5-7
Customizing Application Macro Parameters 5-7
Password Protection (Parameter Lock) 5-8

Chapter 6 – Fault Tracing

Warning and Fault Messages 6-1
 Warning messages of ACH 502/504 6-1
 Fault messages of ACH 502/504 6-2

Appendix A – ACH 502/504 Technical Data

Input Power A-1
Output Power A-1
Analog Inputs A-1
Auxiliary Voltage (for Controls) A-2
Digital Inputs A-2
Analog Outputs A-2

Digital Relay Outputs	A-2
Environmental Limits	A-2
Enclosures	A-2
Glossary	G-1
Index	I-1

This page intentionally left blank.

Chapter 1 – Introduction

This chapter describes the purpose and contents of this manual, describes the intended audience, explains conventions used in this manual, and lists related publications.

How To Use This Manual

The purpose of this manual is to provide you with the information necessary to install, start-up, and service an ACH 502/504 Adjustable Frequency AC Drive rated 60 to 400 hp. This manual also describes features and functions of the drives and requirements such as external drive control connections, wiring, and cable sizes and routing.

ACH 502/504 user documentation also includes the *ACH 500 Adjustable Frequency AC Drives 2 to 400 HP Programming Manual Including Application Macros* which is provided with the drive.

Chapter 1 – Introduction, the chapter you are reading now, introduces you to the *ACH 502/504 Adjustable Frequency AC Drives 60 to 400 HP Installation & Start-up Manual* and conventions used throughout the manual.

Chapter 2 – Overview of the ACH 502/504 describes drive components and provides a brief introduction to Control Panel operation, the drive parameter menu system, and drive Application macros.

Chapter 3 – ACH 502 Installation Instructions describes planning for ACH 502 drive installation, new drive inspection, and drive installation. This chapter also includes requirements and connections for input and output wiring and external control wiring.

Chapter 4 – ACH 504 Installation Instructions describes planning for ACH 504 chassis installation, new drive inspection, and drive installation. This chapter also includes requirements and connections for input and output wiring and external control wiring.

Chapter 5 – Start-up Procedure describes safety, installation inspection, how to check default parameters and set start-up parameters, and how to test the drive with the motor disconnected and connected.

Chapter 6 – Fault Tracing describes troubleshooting procedures through fault messages, resetting faults, accessing stored information in the fault history, and tracing faults to their origins.

Appendix A – ACH 502/504 Technical Data lists input and output voltages, amperage, and other useful data for each drive rated 60 to 400 hp.

Glossary lists and defines terms common to all ACH 502/504 drives.

Index helps you locate the page numbers of topics contained in this manual.

Intended Audience

The audience for this manual has:

- Knowledge of standard electrical wiring practices, electronic components, and electrical schematic symbols.
- Minimal knowledge of ABB product names and terminology.
- No experience or training in installing, operating, or servicing the ACH 502/504.

The audience for this manual will install, start-up, and service the ACH 502/504.

Conventions Used In This Manual

Listed below are terms and language conventions used in this manual. These terms and conventions are defined here to help you understand their meanings and applications throughout this manual. For a complete listing of ACH 502/504 terms, refer to the *Glossary* at the end of this manual.

Control Panel Display

The Control Panel display is an LCD readout of drive functions, drive parameter selections, and other drive information. Letters or numbers appear in the display according to which Control Panel keys you press.

Control Panel Keys

Control Panel keys are flat, labeled, push-button-type devices that allow you to monitor drive functions, select drive parameters, and change drive macros and settings.

Main

A main is the first level of programming. The Mains organize the Parameters into four main functional groups. A Main in this manual is the number corresponding to Group access. All Groups in the 10s range are accessed on the Control Panel through CONTROL CONNECTIONS/MAIN 10. Access Groups in the 20s range through DRIVE PARAMETERS/MAIN 20. Access Groups in the 30s range through PROTECTION PARAMETER/MAIN 30, and access Groups in the 40's range through APPLIC PARAMETERS/MAIN 40.

Group

A Group is a sub-set of a Main. Groups are grouped within Mains according to their 10s, 20s, 30s, or 40s range. For example, Groups numbered 30.1, 30.2, 30.3, and 30.4 are found in PROTECTION PARAMETER/MAIN 30. Parameters are accessed through Groups.

Parameter

A parameter is a sub-set of a Group, selected through the Control Panel keys. Parameters in this manual often are expressed as a number, a decimal (.), another number, a decimal, and another number. The first number at the left represents the Main. The number between the decimals represents the Group, for example, 20.2 (Start/Stop). The number at the right represents a Parameter within that group, for example, 4 (Brake Chopper). In this manual, Parameter 4 in Group 20.2 is expressed as Parameter 20.2.4.

Press

Press a key on the Control Panel to achieve a desired result. In this manual, individual Control Panel keys are enclosed in square brackets. For example, the Setting mode key is expressed as [*]. Refer to *Chapter 2 – Overview of the ACH 502/504, Control Panel Operation*, for details.

Terminal Block

A terminal block is a group of wire connections on a drive. This manual expresses specific terminal blocks and connections as a letter, usually X, a number, a colon (:), and another number. The letter and number to the left of the colon represent the name of the terminal block, for example, X25. The number to the right of the colon represents the terminal connection, for example 16, on the terminal block. In this manual, a terminal connection numbered 16, located on a terminal block named X25, is expressed as X25:16.

Warranty and Liability Information

The warranty for your ABB drive covers manufacturing defects. The manufacturer carries no responsibility for damage due to transport or unpacking.

In no event and under no circumstances shall the manufacturer be liable for damages and failures due to misuse, abuse, improper installation, or abnormal conditions of temperature, dust, or corrosives, or failures due to operation above rated capacities. Nor shall the manufacturer ever be liable for consequential and incidental damages.

The period of manufacturer's warranty is 12 months, and not more than 18 months, from the date of delivery.

Extended warranty may be available with certified start-up. Contact your local distributor for details.

Your local ABB Drives company or distributor may have a different warranty period, which is specified in their sales terms, conditions, and warranty terms.

If you have any questions concerning your ABB drive, contact your local distributor or ABB Drives office.

The technical data and specifications are valid at the time of printing. ABB reserves the right to subsequent alterations.

Related Publications

For related information, refer to the *ABB ACH 500 Adjustable Frequency AC Drives 3 to 400 HP Programming Manual Including Application Macros (ACH 500-05)*.

This page intentionally left blank.

Chapter 2 – Overview of the ACH 502/504

The ACH 502 and ACH 504 are adjustable frequency AC drives for 60 to 400 hp variable torque applications. The ACH 504 is an open chassis, designed for mounting into a customer's enclosure. The ACH 502 is a complete enclosed assembly (including the ACH 504 module) ready for operation.

This chapter describes the features and functions of the ACH 502, and includes illustrations and block diagrams. It also describes the ACH 502 hardware components and the Control Panel displays and keys. This chapter also presents an overview of the Parameters menu system and Application macros.

Nameplate Identification

Figure 2-1 explains the base drive part number used to derive the drive code printed on the nameplate, located at on the right side of the enclosure, or inside the door of the ACH 502, or on the left side below the brake terminals on the ACH 504.

Figure 2-1 Explanation of ACH 502/504 Drive Code

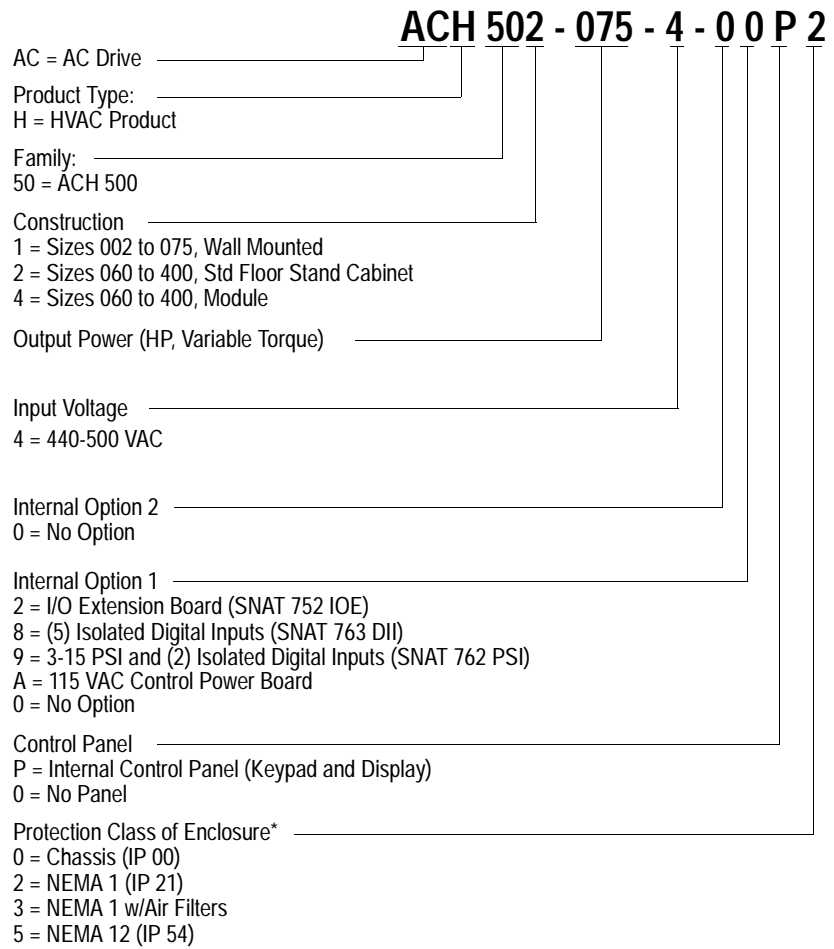

*Not all Protection Classes are available for all units.

Types and Ratings of the ACH 502/504

Table 2-1 shows the type series and ratings of the ACH 504.

Table 2-1 Rating Table for ACH 502 and ACH 504, 440 – 500 VAC

Drive Type	Variable Torque			I_N	Dimension Reference
	hp	Amps (Current Rating of Drive)			
		I_{RSQ}	I_{INSQ}		
ACH50X-060-4-	60	77	69	65	R6
ACH50X-075-4-	75	96	87	84	
ACH50X-100-4-	100	124	111	112	
ACH50X-125-4-	125	156	141	135	R7
ACH50X-150-4-	150	180	159	164	
ACH50X-200-4-	200	240	214	200	R8
ACH50X-250-4-	250	302	269	240	
ACH50X-300-4-	300	361	328	300	R9
ACH50X-350-4-	350	414	376	365	
ACH50X-400-4-	400	460	418	365	

Table 2-2 shows the definitions for symbols used in this manual.

Table 2-2 Symbol Definitions

Symbol	Definition
V_{IN}	Rated supply voltage [V]. The actual voltage is set by a parameter.
I_{INSQ}	Approximate input current when shaft power is P_{RSQ} , line voltage is 480 V and the motor is a standard NEMA motor. This is the maximum thermal input current [RMS Amps].
I_{RSQ}	Rated output current in squared torque applications [RMS Amps].
P_{RSQ}	Maximum motor nominal shaft power in squared torque applications for 2-, 4-, and 6-pole standard motors [hp].
I_N	The output current on which the drive's internal trips and settings are based [Amps].

ACH 502 Control Identification

The numbers and letters in the last seven spaces of the ACH 502 Model Number stand for the specific options included with your drive. Locate the Control Nameplate on the right side of the enclosure or inside the door of the ACH 502 and use Figure 2-2 to verify the options included with your drive. The first part of the part number is derived from Figure 2-1 by removing the letters AC in the first two places and the dashes (-).

Figure 2-2 Nameplate Codes

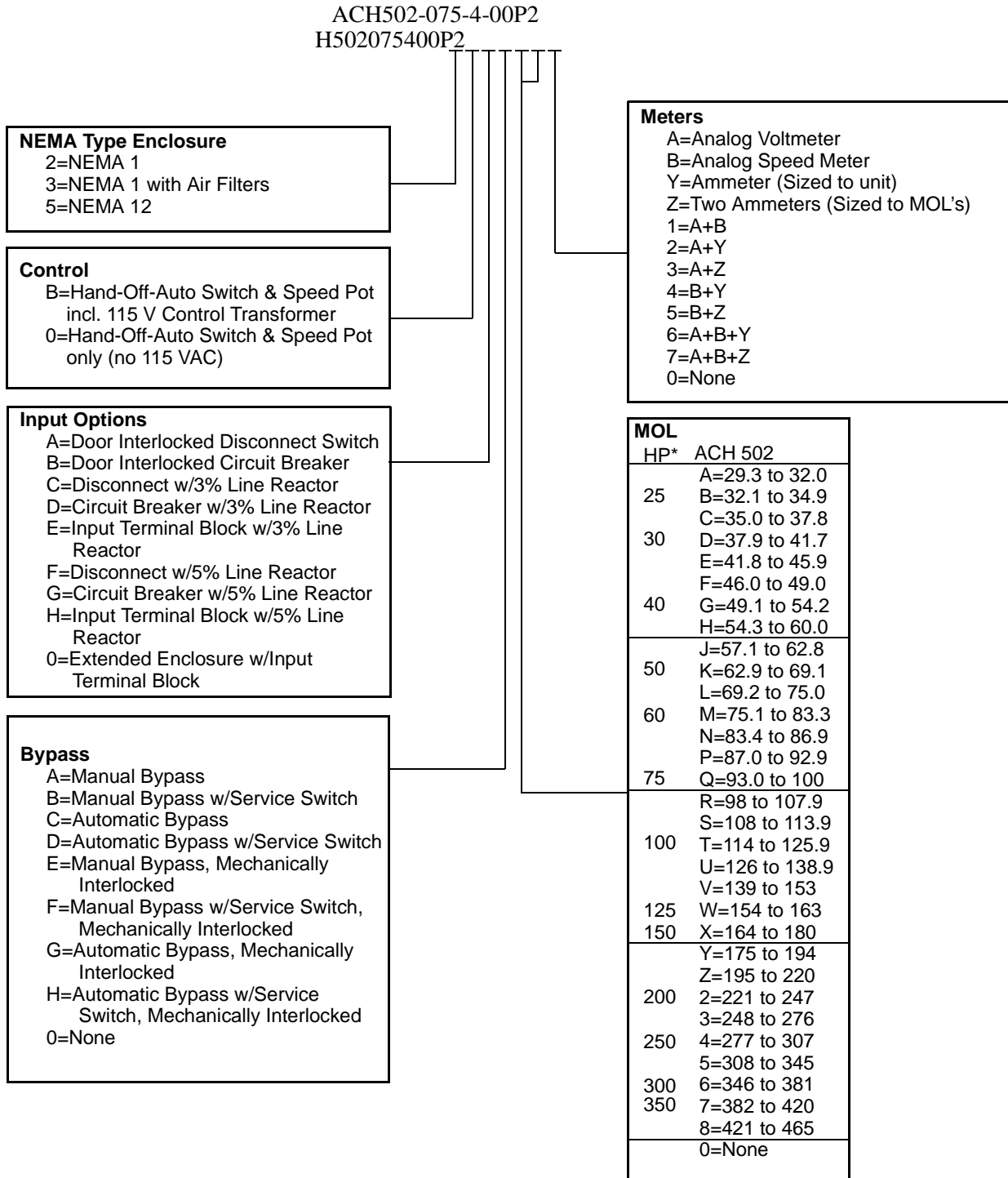

* Horsepowers listed are estimated only.
MOL's MUST be sized for the specific motor.

General Information

About Your ACH 502/504

Functional Description

Power-on sequence

When line voltage is switched on, the capacitor bank is charged first via the charging circuit. The charging takes less than one second. During this time, the thyristors on the rectifier bridge are not conducting.



GENERAL WARNING! The maximum permissible number of chargings in one minute is four. If the DC bus is charged more often, the charging resistor may fail due to excess heat. Therefore, it is recommended that you do not use the input power switching on and off as a Start/Stop command.

The power supply of the ACH 504 comes from the capacitor bank. The power supply turns on when the voltage on the capacitors has reached about 300 VDC. Subsequently, the Control Interface Card, Motor Control Card and Main Circuit Interface Card are energized.

When the DC-voltage has reached 80% of its nominal value, the microprocessor on the Motor Control Card energizes the Input Protection Card. The thyristors are gated fully conducting and the thyristor-diode rectifier behaves like a normal 6-pulse diode bridge.

The cooling fan turns on at initial power-on. To prolong the useful life of the fan bearings, the fan is automatically turned off after one minute, unless:

- The drive has a RUN command, or
- Heatsink temperature is above 113°F (45°C).

Control

In normal duty the drive follows commands and references either from the keypad or the terminal block on the Control Interface Card. The control signal source selection and the way the drive interprets these signals are configured by parameters.

Power section

Power flow through the drive in normal duty is from AC-input line through the rectifier bridge to the DC-filter capacitors which sustain a constant DC-voltage. The nominal value for this voltage is $1.35 \times V_{IN}$.

The Inverter consists of six power semiconductor switches whose operation is controlled by the Motor Control Card via the Main Circuit Interface Card. Turning these switches on and off in a certain sequence is called modulation. The modulation frequency in the ACH 504 is about 3 kHz at maximum and cannot be altered.

The potential at any terminal U_2 , V_2 , W_2 (T_1 , T_2 , T_3) of the inverter can only be high or low. The modulation determines which one. At any instant, the line to line output voltage is either 0 V when the switches in these phases are in the same position or $\pm 1.35 \times V_{IN}$ when the corresponding switches are in different positions.

The output voltage waveform is a pulse-train. The widths of the pulses depend on the modulation. The purpose of the modulation is to create the fundamental voltage wave (its amplitude and frequency), e.g., according to the law $V_{\text{out}} / f_{\text{out}} = \text{constant (V/Hz)}$.

The distortion of the output voltage from the sinusoidal fundamental creates corresponding harmonics in the motor current. However, since the motor is highly inductive and the modulation frequency is relatively high, the current waveform is nearly sinusoidal.

Protective features

Should something adverse happen during power-up or normal duty, the drive incorporates the following features to protect itself:

- Internal overtemperature (warning and trip)
- Overcurrent (two current limits and trip)
- Input line phase loss / unbalance (trip)
- Overvoltage (trip at 130% nominal DC-voltage)
- Undervoltage (trip at 60% nominal DC-voltage)
- Starting at overvoltage (>117% of nominal DC-voltage inhibits start)
- Ground Fault (>2.5 amps)

In addition, the drive identifies various internal and external hardware faults and displays a diagnostic message.

Ground fault detection test is performed each time a start command is given.

The ACH 504 also has a variety of protective features for the motor, such as:

- Stall (warning and trip)
- Overload (warning and trip)
- Underload (warning and trip)

Power-off sequence

A high voltage remains on the capacitor bank after the line voltage is disconnected. This voltage is discharged through discharging resistors (R11) within five minutes. Always use a voltage measurement to determine that the voltage has dropped before performing any service or making main circuit connections. Measure between terminals UDC+ and UDC-; also measure between UDC+ and chassis ground. The meter must be capable of withstanding 1000 VDC.

Control Panel Operation

Control Panel Display The Control Panel, located on top of the Control Interface Card, has a 2x20 character alphanumeric LCD and a keypad.

The operation information, parameters and fault indications are displayed in nine languages: English, German, Italian, Spanish, Dutch, French, Danish, Finnish, and Swedish. The language selection is made in Start-up Data, Parameter A (Language).





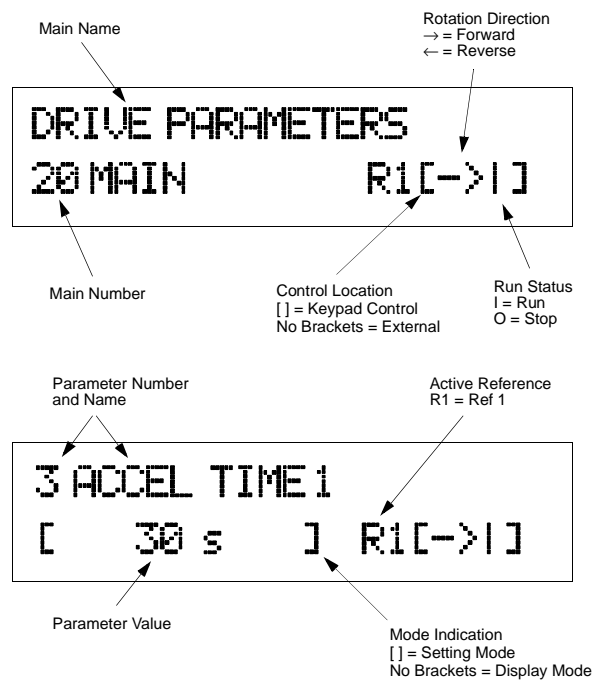

Figure 2-3 shows control panel display indications.

Figure 2-3 Control Panel Displays



Control Panel Keys Table 2-3 illustrates each Control Panel Key, how the keys are used in this manual’s text, and describes the function of each key.

Table 2-3 Control Panel Keys

Control Panel Key	Text Reference	Function
	[*]	Selects the Setting mode and saves the selected parameter value.
 	[Right Arrow] [Left Arrow]	Steps between levels. Selects between Operating Data, Main, Group, and Parameter levels. and In Setting Mode, returns to the Display mode without changing the Parameter value.
 	[Up Arrow] [Down Arrow]	Steps through choices within a level. In Display mode, selects the next/previous Main, Group, or Parameter. and In Setting mode, increases/decreases parameter value.
	[Fwd/Rev]	Changes the rotation direction in Keypad control (refer to parameter 10.1.3).
	[Start/Stop]	Starts and stops the motor in Keypad control. Resets faults, warnings, and supervision indications.

Note: To accelerate the change of parameter value, press and hold the [Up Arrow] or [Down Arrow] button.

Figure 2-4 shows how to set Parameter 20.1.1 (Minimum Frequency) to 3 Hz.

Figure 2-4 Parameter Settings

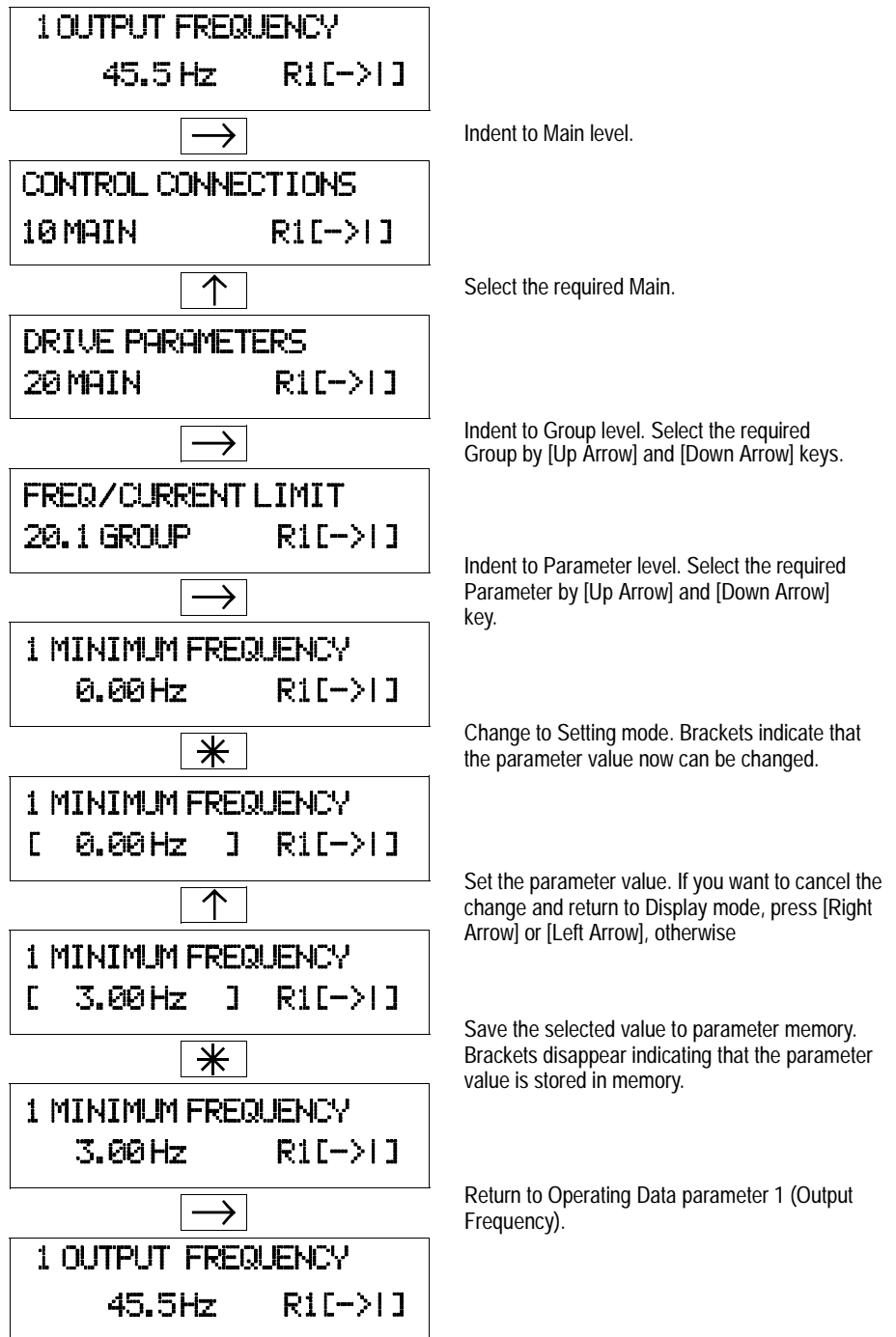

Adjusting Display Contrast The contrast of the LCD can be adjusted for optimal viewing. This can be done when the display is in the Main or Group level.

To adjust contrast, press and hold [*] and then press [Up Arrow] or [Down Arrow].

You may need to adjust the display contrast if the ACH 502 has been installed in a location with high ambient temperatures. The factory default setting is optimum for an ambient temperature between 59°F and 86°F (15°C and 30°C).

Application Macros Overview

Application macros are complete sets of default parameter settings for some typical applications. This allows all of the parameters to be set with the touch of a button.

When you select an Application macro, the parameters listed in the *ACH 500 Adjustable Frequency AC Drives 3 to 350 HP Programming Manual Including Application Macros* are set to a value suitable for a particular application. The parameters which are not included in the Application macro retain the factory settings. If you must adjust the parameter values, refer to the instructions in the *ACH 500 Adjustable Frequency AC Drives 3 to 350 HP Programming Manual Including Application Macros*.

Hardware Description

The ACH 504 chassis units consist of a Control Unit and an Inverter Module. These communicate via a multi-conductor cable.

The ACH 502 series drives consist of an ACH 504 chassis unit mounted in an enclosure.

Inverter Module

Figure 2-5 shows the components of the ACH 504. Table 2-4 gives the description of the components.

Figure 2-5 ACH 504 Components

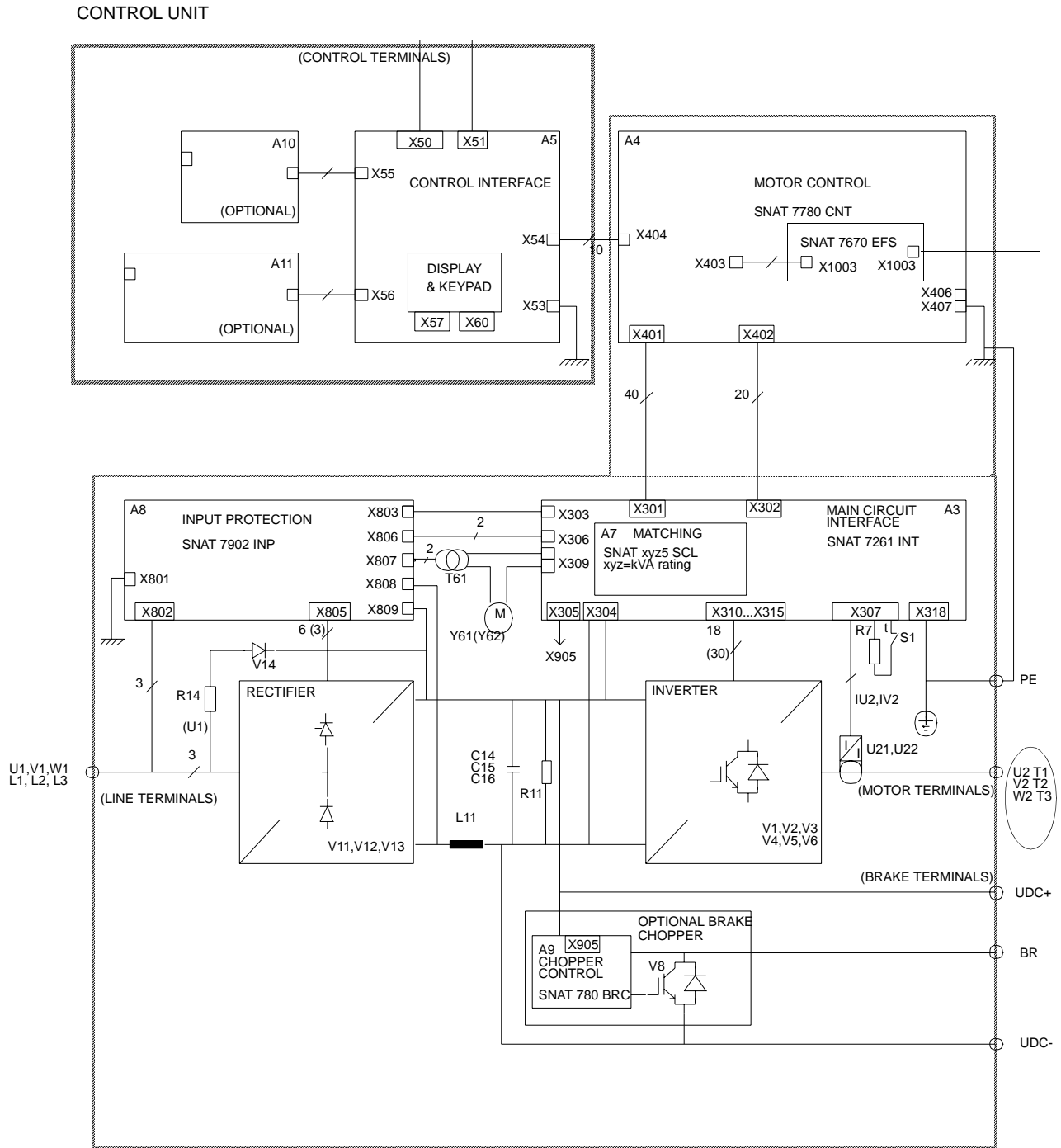

INVERTER MODULE

acsblkus.drw

Table 2-4 ACH 504 Inverter Module Component Description

Component	Component Description
R14, V14	Pre-charging circuit for limiting the current surge when power is first applied.
V11, V12, V13	Rectifier bridge. This is a half-controlled thyristor bridge. During pre-charging, the thyristors are blocked and thereafter they are gated fully conducting.
A8	Input Protection Card SNAT 7902 INP. This contains gate trigger circuits for the rectifier thyristors, capacitors, and varistors to protect the bridge. It also contains fuses to protect the fan.
L11, C14 – C16, R11	DC-filter choke and capacitors with discharge resistors.
V1 – V6	Inverter insulated gate bipolar transistors (IGBT) and clamp circuits.
A3	Main Circuit Interface Card SNAT 7261 INT. This card contains the power supply, transistor gate trigger circuits, and DC-voltage and motor current measurement circuits.
A7	Small card on top of SNAT 7261 INT. This contains the power range programming information for the ACH 504 hardware. (SNAT xyz5 SCL, where xyz is the kVA rating of the Module).
U21, U22	Current transducers for motor current measurement.
Y61, Y62	Cooling fan(s) and associated transformer (T61). Note: the transformer connection must be made according to the actual supply voltage. Supply voltage is set to 500 V at the factory.
R7	Measures the temperature of the heatsink. The thermostat (S1) provides thermal protection for those parts that are not covered by R7.
(V8, A9)	Optional braking chopper: transistor and its control card SNAT 780 BRC. The braking resistor is outside the module.
A5	Control Interface Card contains the display, keypad, and terminal block X50 for control wiring. RS485 terminals X51, X52, and the programming jumpers for analog inputs are on this card.
A4	Motor Control Card SNAT 777 CNT.
(A10, A11)	Option cards.



GENERAL WARNING! The ACH 504 Inverter Module does not include fuses within the module. Fuses are supplied for separate mounting.



WARNING! Parts within the Inverter Module are at main circuit potential. The printed circuit boards within the Control Unit are grounded. The signal isolation takes place in the Inverter Module.

Features and Functions

The ACH 502 is an enclosed, floor-standing adjustable frequency AC drive. Depending on the options chosen, the ACH 502 provides motor overload protection, disconnect switch or circuit breaker, bypass, analog meters, indicator lights, and external control connections.

Figure 2-6 shows the door of the ACH 502 and indicates all possible options. Your drive may not look exactly like the illustration.

Figure 2-6 ACH 502 Front Door

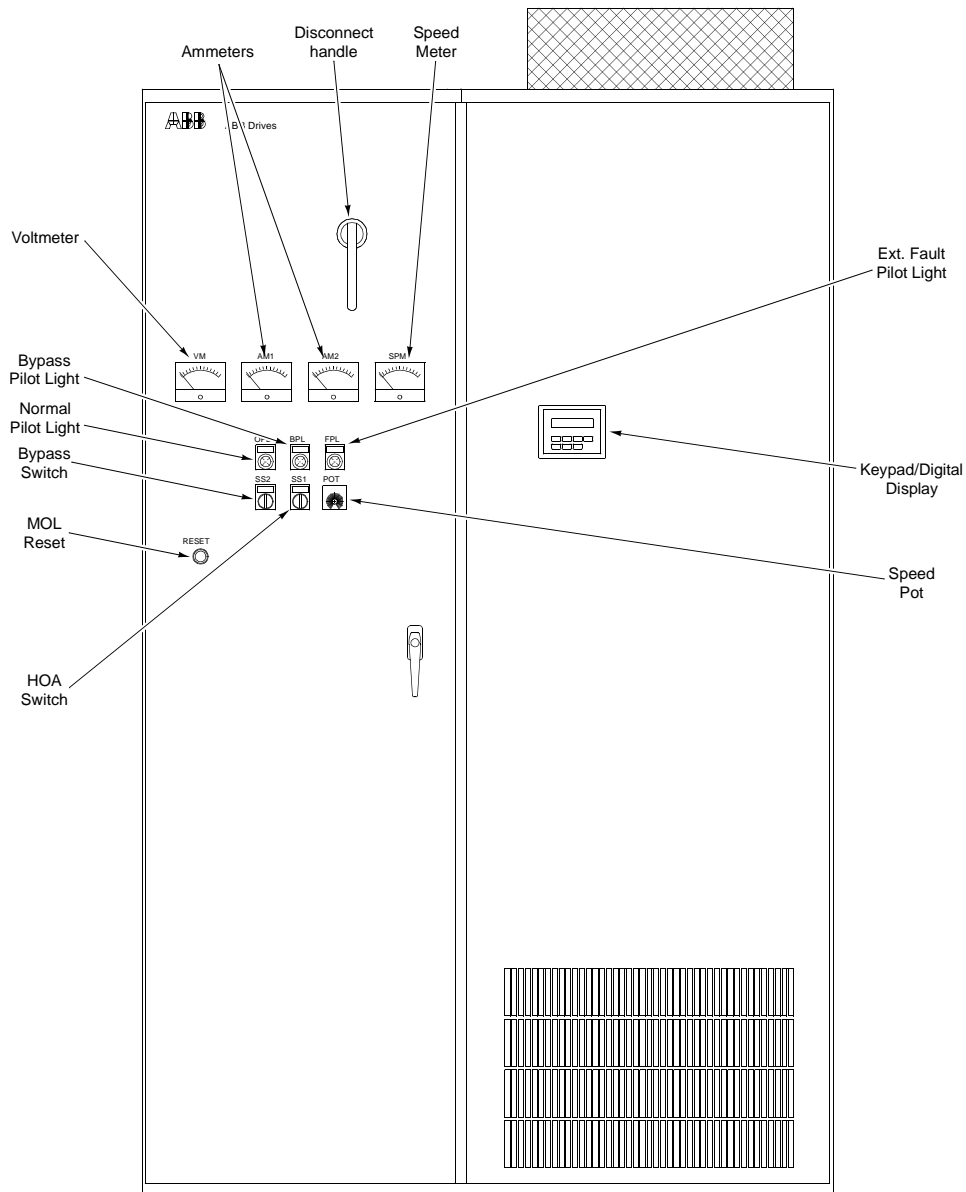
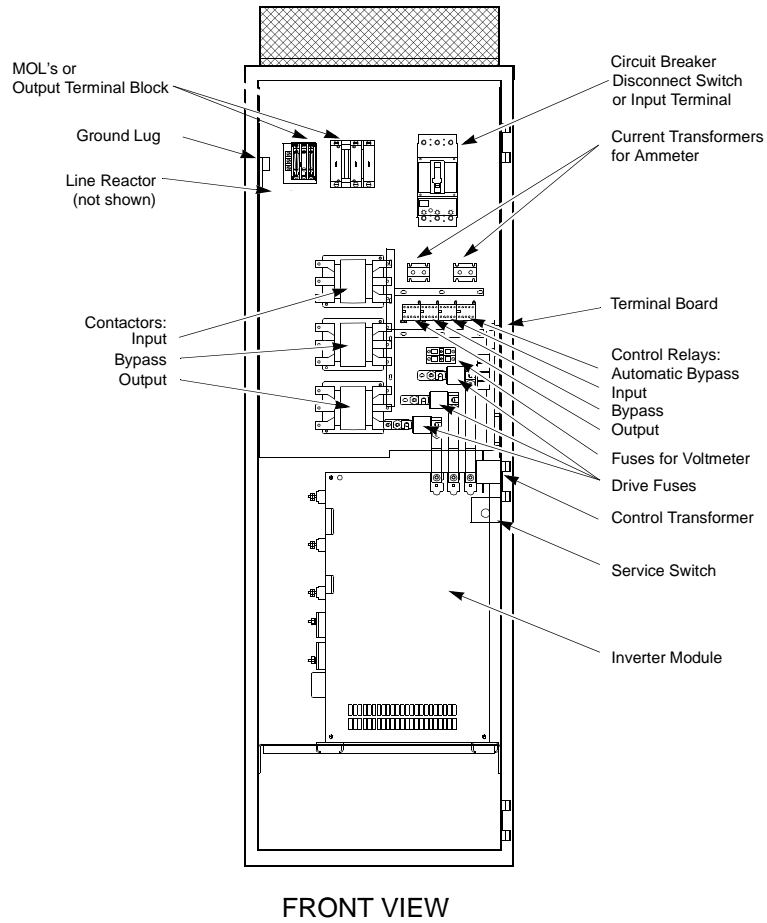

Figure 2-7 and Figure 2-8 show the interiors of the ACH 502 and indicate all possible options. Your drive may not look exactly like the illustration.

Figure 2-7 ACH 502 R6 and R7 with Bypass Interior



a312.dxf

Figure 2-8 ACH 502 R8 with Bypass and R9 Interior

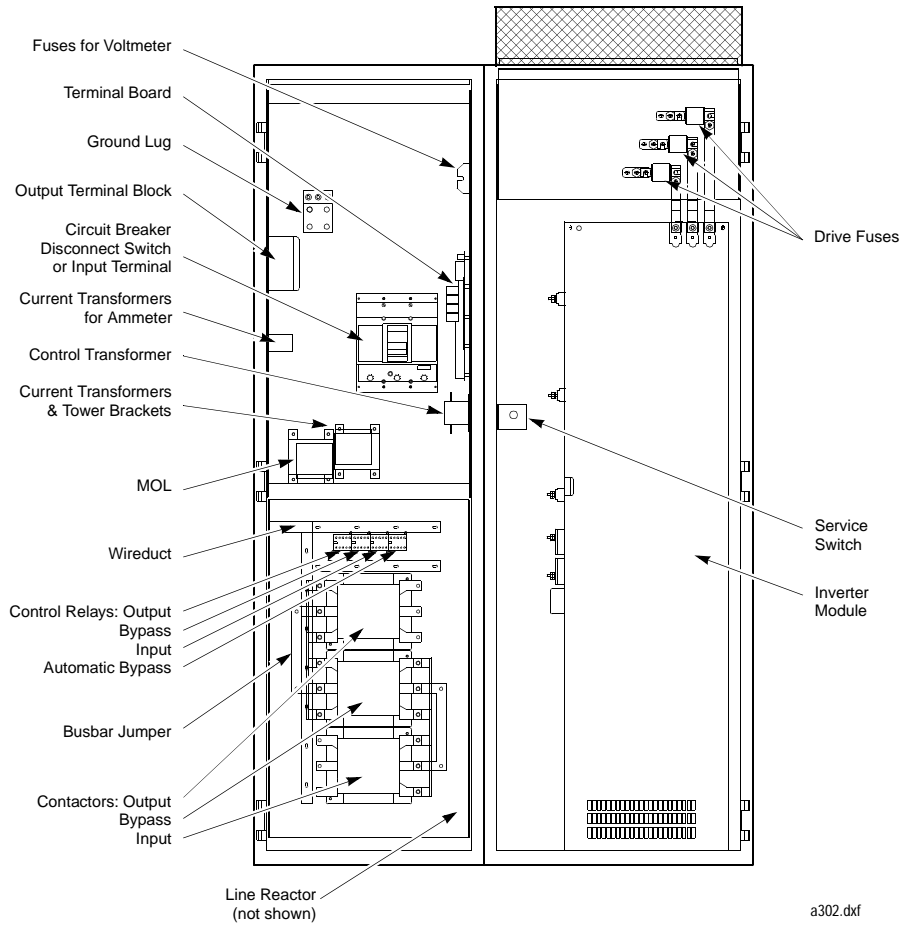

Custom Options

Custom options for the ACH 502 fall into five main categories:

- Control Options
- Input Options
- Bypass Options
- Thermal Overload Relays
- Meters

Control Options

The Control Options are Hand/Off/Auto with Speed Potentiometer including 115 VAC control power and control power transformer and Hand/Off/Auto with Speed Potentiometer only (no 115 VAC).

When Hand/Off/Auto with Speed Potentiometer only is ordered, the top half of the terminal board is not used. This board (illustrated in *Chapter 3 – ACH 502 Installation Instructions* in this manual) is the location of Terminal Block TB1, to which all connections are made. Terminal Board connections are described in this manual. 115 VAC Control is required with all Bypass options.

Hand/Off/Auto with Speed Potentiometer incl. 115 VAC

Hand/Off/Auto with Speed Potentiometer including 115 VAC control power includes a door mounted switch and potentiometer, wired at the factory. This switch allows you to select one of three modes. In the Hand mode, the Drive Enable signal enables the drive and the door mounted speed potentiometer controls the speed. In the Off mode, the drive is disabled even if you use an external speed reference or if you attempt to start the drive via the keypad. In the Auto mode, a remote contact closure starts the drive, provided you have connected a remote contact. A remote signal (voltage or current) controls speed. The remote signal controlling speed can also be pneumatic, but requires an option board. The 115 VAC control transformer provides control voltage.

Hand/Off/Auto with Speed Potentiometer Only

Hand/Off/Auto with Speed Potentiometer is the same as Hand/Off/Auto with Speed Potentiometer above except the 115 VAC control transformer is not supplied. The Hand/Off/Auto switch is wired into the +24 VDC circuits instead of the 115 VAC control transformer.

Input Options

The Disconnect Options are the Door Interlocked Disconnect Switch and the Door Interlocked Circuit Breaker.

Door Interlocked Disconnect Switch

The Door Interlocked Disconnect Switch is a non-fused disconnect switch. Fuses are provided as standard, mounted separately.

Door Interlocked Circuit Breaker

The Door Interlocked Circuit Breaker is a thermal magnetic, molded case circuit breaker.

Both options are a thru-the-door interlock design and can be padlocked in the OFF position.

Input Line Reactor

3% or 5% input line reactors to reduce the harmonics to the power line.

Bypass Options

The Bypass Options are:

- Manual Bypass,
- Manual Bypass with Service Switch,
- Automatic Bypass, and
- Automatic Bypass with Service Switch.

Manual Bypass

The Manual Bypass option is a selector switch which transfers the motor to line power and allows the motor to operate at full speed.

Note: If motor overload is not provided, one must be installed external to the drive and sized in accordance with NEC.

The Manual Bypass option has two contactors, electrically interlocked and controlled by a three position, door-mounted switch. Switch positions are NORMAL, TEST, and BYPASS. In the NORMAL position, the Bypass contactor is open, the Output contactor is closed, and the Normal indicator light is illuminated. In the TEST position, both contactors are open. In the BYPASS position, the Output contactor is open, the Bypass contactor is closed, the drive is disabled, and the Bypass indicator light is illuminated. A circuit breaker protects the motor in the Bypass mode.

An External Fault indicator light is included. The External Fault indicator light illuminates if any of the safety interlocks (FREEZE, FIRE, SMOKE) open, or if the Thermal Motor Overload Relay trips.

CAUTION: When changing from Bypass to Normal, place the Bypass Switch in the TEST position for five seconds before selecting Normal. Failure to do so could result in damage to the ACH 502.

Note: The ACH 502 is disabled when BYPASS is selected. If the drive is to be run while in BYPASS, a connection must be made between TB1:42 and TB1:43. This should be done by a qualified service technician only.

CAUTION: Remove the jumper before switching from BYPASS to NORMAL. Failure to do so could result in damage to the ACH 502.

Note: The Output contactor opens when the drive receives a stop command, which will cause the motor to coast to a stop. If ramp to a stop is required by the application, it will be necessary to install wires from TB1:25 to TB1:40 and from TB1:26 to TB1:41. This will cause the Output contactor to remain closed until the output frequency reaches 0 Hz when a stop command is received.

CAUTION: If BYPASS is selected, and the motor is not running because a stop command is given, the motor will start when the drive is started.

*Manual Bypass with
Service Switch*

The Manual Bypass with Service Switch option is the same as the Manual Bypass option with the addition of another switch, and a third (input) contactor on the line power side of the drive. The additional switch allows you to apply power to, or remove power from the drive for servicing while the motor continues to operate on line power. In the BYPASS position, the Drive Input contactor opens and removes power from the drive. The Drive Input contactor is also controlled by the three position Service Switch, with the positions labeled NORMAL, OFF, and TEST. This switch is mounted inside the enclosure. In the NORMAL position, the Bypass switch controls the Drive Input contactor. In the TEST position, the Drive Input contactor is closed. In the OFF position, the Drive Input contactor is open.

Note: The Drive Input contactor opens when BYPASS is selected, removing power from the drive. The service switch will energize the input contactor in the TEST position to allow the drive to be powered while in BYPASS for servicing.

Note: The ACH 502 is disabled when BYPASS is selected. If the drive is to be run while in BYPASS, a connection must be made between TB1:42 and TB1:43. This should be done by a qualified service technician only.

CAUTION: Return the service switch to Normal and remove the jumper from TB1:42 to TB1:43 before switching from BYPASS to NORMAL. Failure to do so could result in damage to the ACH 502.

Note: The Output contactor opens when the drive receives a stop command, which will cause the motor to coast to a stop. If ramp to a stop is required by the application, it will be necessary to install wires from TB1:25 to TB1:40 and from TB1:26 to TB1:41. This will cause the Output contactor to remain closed until the output frequency reaches 0 Hz when a stop command is received.

CAUTION: If BYPASS is selected, and the motor is not running because a stop command is given, the motor will start when the drive is started.

Automatic Bypass An Automatic Bypass may be added to the Manual Bypass or Manual Bypass with Service Switch. The Automatic Bypass automatically transfers the motor to line power when the drive shuts down on a protective trip. If Automatic Restart is enabled on the drive, the drive will attempt to automatically restart before the motor transfers to line power. Bypass transfer occurs when the drive is in a fault condition and will not reset. When an automatic transfer occurs, the Bypass indicator light illuminates.

Thermal Motor Overload Relays The Thermal Motor Overload Relay Options are relays rated 30, 60, 100, or 180 amps in-line with the output power, and 26 amp relay with 500:5 current transformers for ratings from 180 to 500 amps. These options are standard, manually resettable, bimetallic motor overload relays with a Class 20 trip curve. The relays provide thermal motor protection when operating a motor from the drive. If a Bypass Option is included, the relays also provide thermal motor protection across the line power. If the overload trips, power is removed from the motor whether in Normal or Bypass mode. When the drive has the Bypass option, an external fault indicator is included. This indicator will illuminate if the overload relay trips. The overload relay is reset by a pushbutton on the enclosure door.

Thermal Motor Overload Relays have heater elements to determine the trip level of the overload relay. The heater element type is stamped on the element. If the overload is not sized properly for the motor, purchase new heaters of the correct size. See the following tables for heater sizes. Table 2-5 shows heater sizes for the 30, 60, 100, and 180 amp Furnas relays. Table 2-6 is for ratings over 180 amps, which are Square D devices. Your ACH 502 may have either one or two overload relays, depending upon how many motors the drive controls.

Table 2-5 Heater Sizes for Furnas Relays

Furnas Heater Code	Amps 30	60	100	180
E3 E4 E5 E6 E7	.30 – .32 .33 – .35 .36 – .38 .39 – .41 .42 – .44			
E8 E9 E11 E12 E13	.45 – .49 .50 – .54 .55 – .58 .59 – .63 .64 – .67			
E14 E16 E17 E18 E19	.68 – .73 .74 – .81 .82 – .87 .88 – .94 .95 – 1.00			
E23 E24 E26 E27 E28	1.10 – 1.10 1.11 – 1.26 1.27 – 1.40 1.41 – 1.58 1.59 – 1.74			
E29 E31 E32 E33 E34	1.75 – 1.85 1.86 – 1.99 2.00 – 2.11 2.12 – 2.31 2.32 – 2.59			
E36 E37 E38 E39 E41	2.60 – 2.75 2.76 – 2.95 2.96 – 3.21 3.22 – 3.48 3.49 – 3.89			
E42 E44 E46 E47 E48	3.90 – 4.35 4.36 – 4.73 4.74 – 5.21 5.22 – 5.74 5.75 – 6.05			
E49 E50 E51 E52 E53	6.06 – 6.46 6.47 – 6.95 6.96 – 8.09 8.10 – 9.29 9.30 – 10.4			
E54 E55 E56 E57 E60	10.5 – 10.9 11.0 – 12.0 12.1 – 14.5 14.6 – 16.8			

Furnas Heater Code	Amps 30	60	100	180
E61 E62 E65 E66 E67	16.9 – 18.4 18.5 – 20.9 21.0 – 22.5 22.6 – 24.3 24.4 – 27.2	16.9 – 18.4 18.5 – 20.9 21.0 – 22.5 22.6 – 24.7 24.8 – 27.2	27.1 – 30.0	
E69 E70 E71 E72 E73	27.3 – 29.2 29.3 – 30.0	27.3 – 29.2 29.3 – 32.0 32.1 – 34.9 35.0 – 37.8	30.1 – 33.2 33.3 – 35.7 35.8 – 39.4 39.5 – 43.4 43.5 – 46.9	
E73A E74 E76 E77 E78		37.9 – 41.7 41.8 – 45.9 46.0 – 49.0 49.1 – 54.2 54.3 – 60.0	47.0 – 51.5 51.6 – 57.0 57.1 – 62.8 62.9 – 69.1	
E79 E80 E88 E89 E91			69.2 – 75.0 75.1 – 83.3	50.0 – 55.9 56.0 – 60.9 61.0 – 65.9
E92 E93 E94 E96 E97			83.4 – 86.9 87.0 – 92.9	66.0 – 69.9 70.0 – 75.9 76.0 – 81.9 82.0 – 86.9 87.0 – 92.9
E98 E99 E101 E102 E103			93.0 – 100.0	93.0 – 97.9 98.0 – 107.9 108.0 – 113.9 114.0 – 125.9 126.0 – 138.9
E104 E106 E107				139.0 – 153.0 154.0 – 163.0 164.0 – 180.0

Table 2-6 Heater Sizes for Square D Relays

Heater Code	Amps
AR .45	28.0 – 30.0
AR .49	31.0 – 33.0
AR .54	34.0 – 36.0
AR .59	37.0 – 39.0
AR .65	40.0 – 42.0
AR .71	43.0 – 46.0
AR .78	47.0 – 50.0
AR .86	51.0 – 52.0
AR .95	53.0 – 56.0
AR 1.05	57.0 – 60.0
AR 1.15	61.0 – 66.0
AR 1.26	67.0 – 73.0
AR 1.39	74.0 – 81.0
AR 1.53	82.0 – 90.0
AR 1.68	91.0 – 105.0
AR 1.85	106.0 – 115.0
AR 2.04	116.0 – 125.0
AR 2.24	126.0 – 135.0
AR 2.46	136.0 – 147.0
AR 2.71	148.0 – 158.0
AR 2.98	159.0 – 174.0
AR 3.28	175.0 – 194.0
AR 3.62	195.0 – 220.0
AR 3.98	221.0 – 247.0
AR 4.37	248.0 – 276.0
AR 4.80	277.0 – 307.0
AR 5.3	308.0 – 345.0
AR 5.8	346.0 – 381.0
AR 6.4	382.0 – 420.0
AR 7.0	421.0 – 465.0

Meters The Meter Options are Output Voltmeter, Output Speed Meter, and Output Ammeter. A total of four analog meters can be installed in the ACH 502.

Output Voltmeter The Output Voltmeter indicates motor voltage on a 0 – 500 VAC scale connected directly to the drive output.

Output Speed Meter The Output Speed Meter is calibrated in percent of maximum speed with a 0 – 100 percent scale connected to one of the analog outputs.

Note: This option uses one of the analog outputs on the ACH 502.

Output Ammeters The Ammeters have six calibration sizes ranging from 100 to 500 amps. Depending on the number of motors driven, one or two Output Ammeters can be installed in the ACH 502. If two ammeters are ordered, two Thermal Motor Overload Relays must be ordered; the ammeters are sized to the Thermal Motor Overload Relays. If two Thermal Motor Overload Relays are ordered and only one ammeter is ordered, the ammeter will indicate the sum of the current at the two relays.

This page intentionally left blank.

Chapter 3 – ACH 502 Installation Instructions

This chapter explains how to install the ACH 502 and connect all power, motor, and control wiring. It also describes the initial inspection procedures.

Grounding and Ground Faults

The ACH 502 must always be grounded through a ground conductor connected to the ground terminal.

If the ACH 502 is connected to a system without system ground, the ground fault protection must be capable of starting at ground fault currents containing high frequency and DC components. The ACH 502 ground fault protection guards the variable frequency drive against ground faults occurring in the motor or the motor wiring.

Fault current protective switches do not necessarily operate properly with variable frequency drives. When using such switches their function should be checked at possible ground fault currents arising in a fault situation.

Pre-Installation Planning

This drive has been tested in accordance with UL508. The drives are suitable for use on a circuit capable of delivering not more than 42,000 rms Amperes, 500 Volts maximum. When output chokes are supplied, all units are suitable for use on a circuit capable of delivering not more than 65,000 rms Amperes, 500 Volts.

When circuit breakers are supplied, the drive package is limited to the rating of the circuit breaker, which is 18,000 rms Amperes for the 60 & 75 HP units; 25,000 for the 100 - 150 HP units; and 30,000 for the 200 & 400 HP units.

The ACH 502 is supplied with fast acting semiconductor fuses with an interrupting rating of 200,000 rms symmetrical Amperes.

Environment

These drives are to be used in a heated, indoor controlled environment that is relatively free of moisture and conductive contaminants such as condensation, carbon dust, and the like.

The maximum ambient temperature allowed is 104°F (40°C) for an ACH 502 in a NEMA 1 enclosure for variable torque loads, when the load current is lower than or equal to the continuous maximum load current (I_{RSQ}).

The cooling air must be clean and free from corrosive materials. When necessary the required cooling should be provided by using clean, dry air.

If the cooling air contains dust, clean the cooling surfaces of the unit regularly using compressed air and a brush.

Conduit Size Figure 3-2 and Figure 3-3 show top views of the ACH 502 and conduit entry area. The panels must be removed from the drive before being drilled and punched to prevent metal particles from falling into the drive.

Figure 3-2 ACH 502 Conduit Entry Area for One Door Enclosure

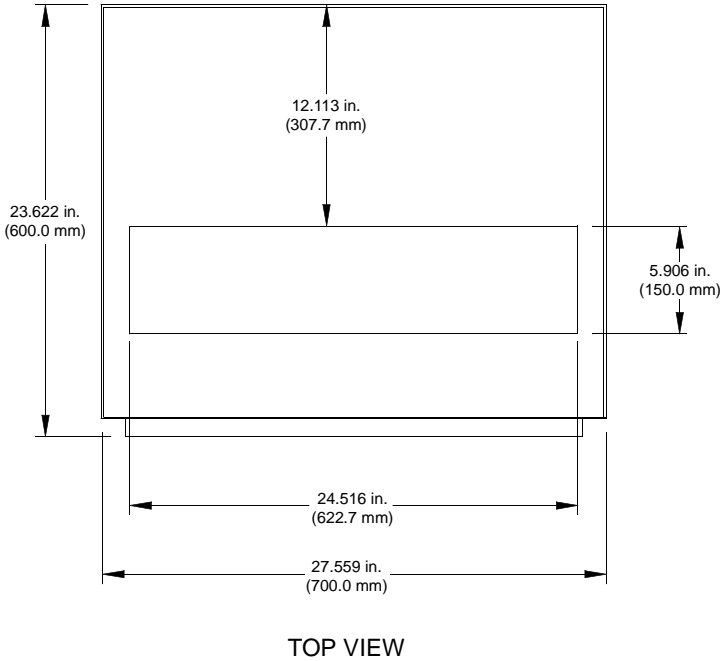

Figure 3-3 ACH 502 Conduit Entry Area for Two Door Enclosure

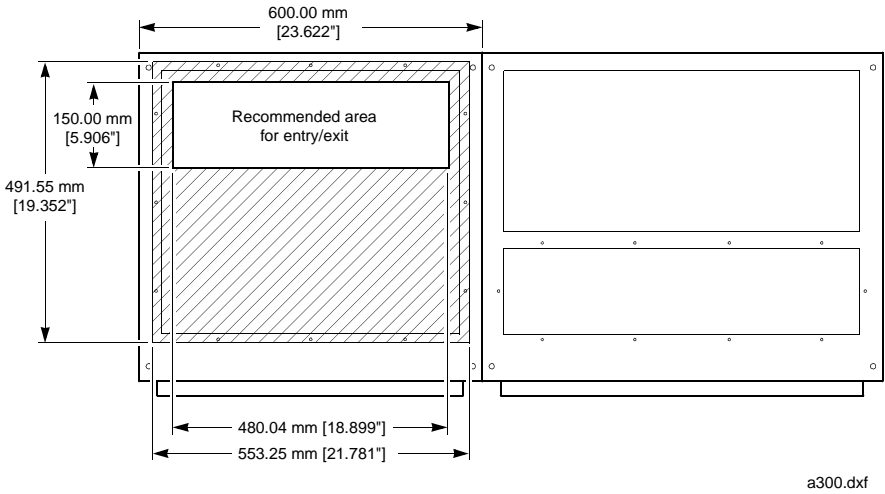

Figure 3-3 shows the left bay at the enclosure only.

Power Wiring All field wiring shall be rated for 167°F (75°C).

Install the motor wiring away from other wire routes. Avoid long parallel runs with other wires.

The tightening torque for the input power connections to the circuit breaker should be 275 in.-lbs. Tightening torques to other termination points should be as labeled on the device.

Table 3-1 shows the allowable input wire sizes for the ACH 502.

Table 3-1 ACH 502 Input Wire Sizes

Drive Type	Terminal Block	Disconnect	Circuit Breaker
ACH 502-060 – ACH 502-150	#6-4/0	#6-4/0	#2-4/0
ACH 502-200 – ACH 502-250	* #6-4/0	* #2-4/0	* 3/0-4/0
ACH 502-300 – ACH 502-400	* #6-500MCM	* #2-500MCM	* 250MCM-500MCM

* Indicates 2 pole per phase for terminal information and 2 conductor for wire size information.

Table 3-2 shows the fuse ratings UL R/C (JFHR2), for the ACH 502.

Table 3-2 ACH 502 Fuse Ratings

Drive Type	Fuse Ratings			Bussmann Type
	A	kA ² s	V	
ACH 502-060-4	160	16	600	170M1369
ACH 502-075-4	200	28	600	170M1370
ACH 502-100-4	200	28	600	170M1370
ACH 502-125-4	400	105	600	170M3019
ACH 502-150-4	400	105	600	170M3019
ACH 502-200-4	550	190	600	170M5011
ACH 502-250-4	550	190	600	170M5011
ACH 502-300-4	700	405	600	170M5013
ACH 502-350-4	700	405	600	170M5013
ACH 502-400-4	700	405	600	170M5013

Output Power Wiring Table 3-3 shows the output wire sizes for the ACH 502.

Table 3-3 ACH 502 Output Wire Sizes

Amp Range	Overload	Terminal Block
29.3 – 60.0	#12 – #2	#6-250MCM
57.1 – 100.0	#10 – 2/0	#6-250MCM
98.0 – 180.0	#6 – 250MCM	#6-250MCM
175.0 – 220.0	* #6 – 4/0	* #6-4/0
221.0 – 465.0	* #6 – 4/0	* #6-4/0

* Indicates 2 pole per phase for terminal information and 2 conductor for wire size information.

Table 3-4 shows ground lug sizes for the ACH 502.

Table 3-4 ACH 502 Ground Lug Sizes

Drive Type	Ground Lug
ACH 502-060 to ACH 502-400	#6-350MCM

Power Connections

Input Wiring

The R6 and R7 ACH 502 units are suitable for use on a circuit capable of delivering not more than 10,000 rms Amperes, 500 Volts maximum. The R8 and R9 units are suitable for use on a circuit capable of delivering not more than 18,000 rms Amperes, 500 Volts maximum.

The ACH 502 is supplied with fast acting semiconductor fuses with an interrupting rating of 200,000 rms symmetrical Amperes.

Four conductors (three phase plus a ground wire) are required for the input and output wiring. Use copper conductor rated for 167°F (75°C). Input and output conductors and branch circuit protection must be sized to local codes.



WARNING:

- Do not connect or disconnect input or output power wiring, or control wires, when power is applied.
- Never connect line voltage to drive output Terminals U₂, V₂, and W₂ (T₁, T₂, T₃).
- Do not make any voltage tolerance tests (Hi Pot or Meggar) on any part of the unit. Disconnect motor wires before taking any measurements in the motor or motor wires.
- Make sure that power factor correction capacitors are not connected between the drive and the motor.

The terminal sizes and tightening torques of the power terminals are shown in the drive. Table 3-1 shows minimum current ratings and maximum I²t ratings for the input fuses to be used with the drive.

Check that the supply capacity is adequate for the drive (P_{RSQ}).

Figure 3-4 shows input power wiring for the ACH 502.

Figure 3-4 Input Power Wiring

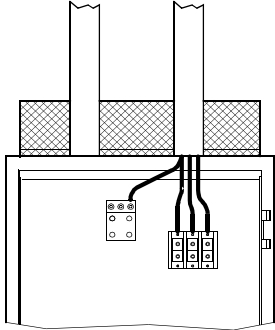

R6 & R7 (all) and R8 w/o bypass

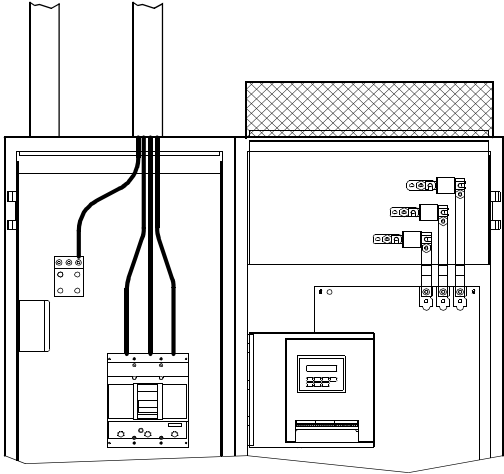

R8 w/bypass and R9 (all)

a317.dxf
a318.dxf

Output Wiring Sizing is the same as for the input wiring.

Figure 3-5 shows output power wiring for the ACH 502.

Figure 3-5 Output Power Wiring

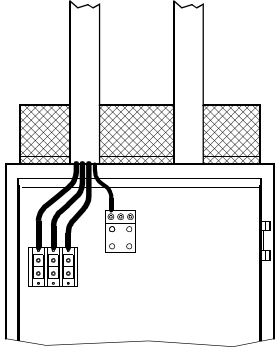

R6 & R7 (all) and R8 w/o bypass

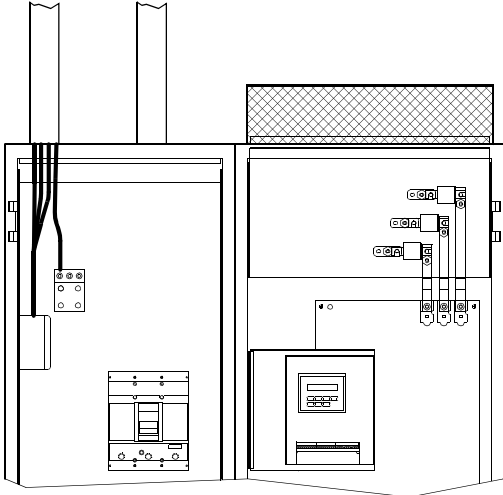

R8 w/bypass and R9 (all)

a317.dxf
a318.dxf

Control Connections

Available Control Locations

The ACH 502 can be controlled from the Keypad or HOA switch and speed pot located on the front of the enclosure or with an external control device.

External control devices, for example a DDC or remote operator devices, can be connected to Terminal Block TB1. These control devices can be Analog or Digital. Refer to *Terminal Block Connections* in this chapter.

When planning control wiring from ACH 502 and external control devices consider the following:

1. All external control wiring to TB1:1 to TB1:20 must be done with shielded cable and must not be run in the same conduit or raceway with any high power wiring. The shield connection must be terminated at the chassis ground lug provided. The other end of the shield should be cut and taped back at the signal source.
2. TB1 terminals 2 and 8 are “GND 2” (circuit common). TB1 terminals 4, 6, 18, and 20 are also connected to circuit common.
3. These terminals are optically isolated from power and isolated from chassis ground by a 10 megohm resistor. They are not isolated from one another.
4. Refer to the *Terminal Block Connections* section in this chapter for an outline of control signal requirements when selecting an Application macro.

Terminal Block Connections

The Terminal Block TB1 is located on the terminal board. Figure 3-6 shows the Terminal Block TB1 connections. Terminals TB1:1 through TB1:29 are the same as terminals X50:1 through X50:29. Refer to the *ACH 500 Adjustable Frequency AC Drives 3 to 350 HP Programming Manual Including Application Macros* to determine the functions of these terminals based on the Application macro selected.

Figure 3-6 Terminal Block TB1 Connections

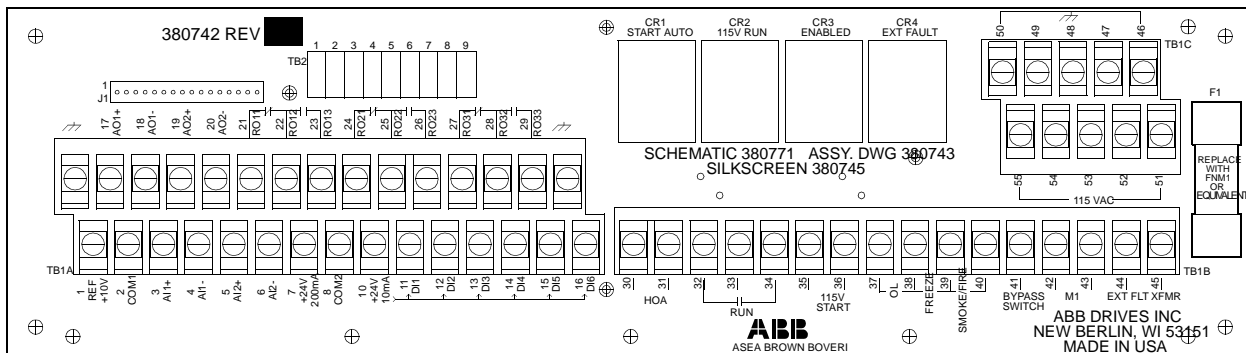

Terminals TB1:1 through TB1:20 are low voltage terminals (24 VDC maximum). Terminals TB1:21 through TB1:29 are relay output terminals.

Ground terminals are located next to TB1:17 and TB1:29. These are to be used to connect the shields of shielded cables.

Terminals TB1:30 through TB1:55 are 115 VAC control. These terminals are not used when the 115 VAC Control Transformer is not supplied.

Connection to all of these terminals is described in the following paragraphs.

Note: When 115 VAC Control Transformer is supplied, the Option Pack macro must be used so the terminal board connections operate properly.

Terminal Block TB1 Terminal Block TB1 can accept wire sizes from 12 – 22 AWG. All connections to Terminals TB1:1 to TB1:20 should be made with shielded cables.

TB1:2, 4, 6, 18, and 20 are circuit common. They are optically isolated from the power line potential and from chassis ground by a 10 megohm resistor. The common points are not isolated from each other.

Figure 3-7 shows connections TB1:1 through TB1:29.

Figure 3-7 TB1:1 Through TB1:29

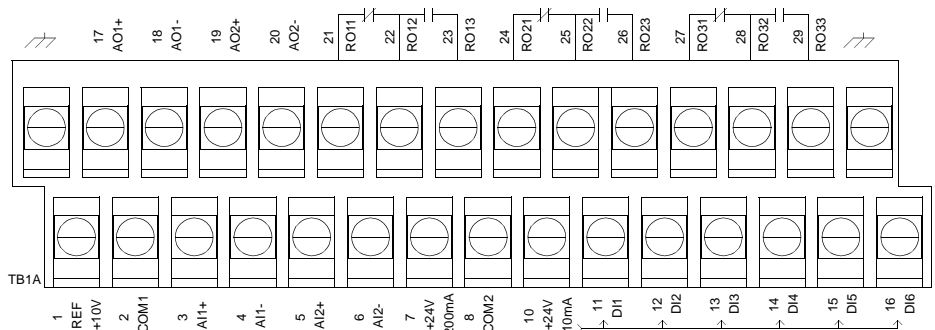

Potentiometer A manual speed potentiometer is connected to the reference at TB1:1 (+10 VDC) and TB1:2 (common), and to one of the analog inputs. The speed potentiometer supplied from the factory for manual (Hand) operation is connected to AI2 (TB1:5).

Analog Inputs The ACH 502 has two analog inputs. AI1 is on Terminals TB1:3 and TB1:4. AI2 is on TB1:5 and TB1:6, and is used by the Manual Speed Potentiometer.

The analog inputs can accept a voltage signal (0 – 10 VDC) or a current signal (0 – 20 mA). Jumpers S1 and S2, located on the Control Interface Board in the ACH 502 (S1 for AI1 and S2 for AI2), determine the signal type.

Place the jumper in the “V” position for voltage or the “I” position for current. Orientation may vary with different versions of the control board. Figure 3-8 shows jumper positions. The shaded areas represent jumper positioning.

Figure 3-8 Jumper Positions

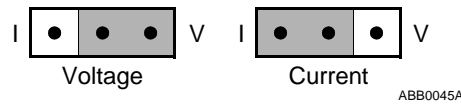

Note: These jumpers are set in the voltage position from the factory. The control interface board assembly is mounted on the door, and is hinged for easy access. To change the jumpers, remove the two screws on the fixed side of the assembly.

Auxiliary 24 VDC An auxiliary +24 VDC supply is available on Terminals TB1:7 and TB1:8. This supply can drive auxiliary devices whose total current draw is less than 200 mA.

Digital Inputs TB1 has six digital inputs, DI1 through DI6 on Terminals TB1:11 through TB1:16 respectively. The digital inputs use 24 VDC logic from terminal TB1:10 and are active high.

DI1, DI2, DI5, and DI6 are used by the logic on the Terminal Board when the 115 VAC control transformer is supplied. DI3 and DI4 can be used for Preset Speeds or floating point control.

When the 115 VAC control transformer is not supplied, DI5 is used for Run Enable. This is used to shut the drive down (i.e., for a contact from a thermal motor overload relay). A contact must be made from X50:10 to X50:15 before the ACH 502 can start. The start signal (dry contact, 2-wire start) is connected from X50:10 to X50:16.

Analog Outputs TB1 has two analog output signals. AO1 is on Terminals TB1:17 and TB1:18. AO2 is on TB1:19 and TB1:20. These signals are 0 – 20 mA (or 4 – 20 mA), and can operate into a maximum 500 ohm load. When the Speed Meter is supplied, it uses AO1.

Digital (Relay) Outputs Three relay outputs are each Form C. Relay RO1 is on Terminals TB1:21, TB1:22, and TB1:23. Relay RO2 is on Terminals TB1:24, TB1:25, and TB1:26. Relay RO3 is on Terminals TB1:27, TB1:28, and TB1:29.

The first terminal for each relay is the normally closed (NC) terminal, the second is the common, and the third is the normally open (NO) terminal.

Maximum Switching Voltage: 300 VDC / 250 VAC.

Maximum Switching Current/Power: 8 A @ 24 VDC, 0.4 A @ 250 VDC, or 2000 VA @ 250 VAC.

Maximum Continuous Current: 2 A rms.

If the relay outputs are used to control inductive loads, such as the coils of relays or contactors, some form of noise suppression must be provided at the load. This is to reduce the electrical noise that could interfere with the electronics in the drive, as well as increase the life of the contacts in the relay.

AC coils should be suppressed with an MOV (metal oxide varistor) or a Series-

Connected RC (resistor capacitor) network, as illustrated below:

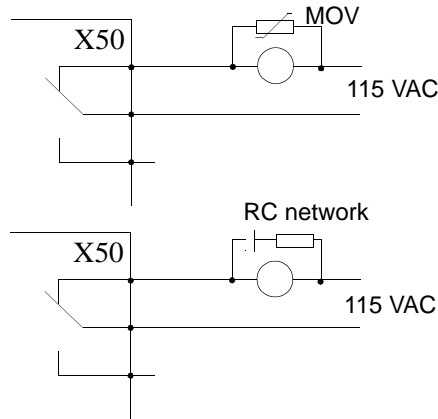

MOV should be rated 120 VAC - 240 VAC for 115 VAC circuits, 240 VAC - 320 VAC for 230 VAC circuits, minimum 10 joules. Values for the RC Network vary, as they effect the opening and closing time. Contact the contactor manufacturer for recommended values.

DC coils should be suppressed with a diode, although this is not required because of the small amount of noise generated by these type of circuits. If a diode is used, it should have a voltage rating greater than or equal to the supply voltage, and be connected as shown below:

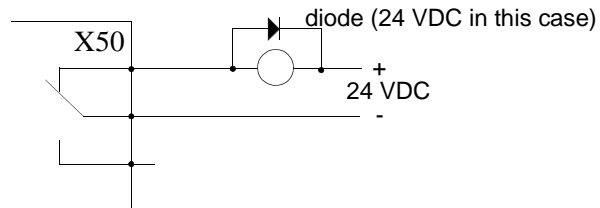
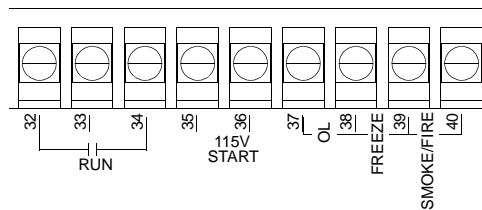

Figure 3-9 shows connections TB1:32 through TB1:40.

Note: The 115 VAC control transformer must be supplied for these terminals to be active.

Figure 3-9 TB1:32 Through TB1:40



**Two-Wire Start
(Dry Contact)**

To start the ACH 502 by dry contact (maintained), connect contact to TB1:32 and TB1:34. This will start the drive in Auto when HOA is supplied, and will start and stop the motor in Bypass when Bypass is supplied. Refer to *Digital Inputs* in this chapter for start command connection when the 115 VAC control transformer is not supplied.

115 VAC Start To start the ACH 502 by applying 115 VAC, connect the 115 VAC signal to TB1:35 and TB1:36. Operation is the same as Two-Wire Start.

Freeze/Fire/Smoke Protection Safety interlocks, such as Freeze, Fire, and Smoke protection are normally closed dry contacts connected in series between TB1:38, TB1:39, and TB1:40. Remove the jumper wire before making your connection. When the contact opens, the motor will stop, whether in NORMAL or BYPASS. When the External Fault indicator is provided (supplied with Bypass Option), the indicator will illuminate when any of these contacts open.

115 VAC Auxiliary Power 115 VAC is available for customer use. There is approximately 100 VA available. TB1:46 through TB1:50 are ground, and TB1:51 through TB1:55 are hot.

Figure 3-10 shows connections TB1:46 through TB1:55.

Figure 3-10 TB1:46 Through TB1:55

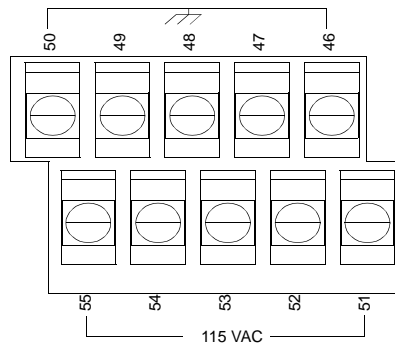

Chapter 4 – ACH 504 Installation Instructions

This chapter explains how to properly install an ACH 504 chassis unit

The ACH 504 chassis includes:

- ACH 504 Inverter Module
- Control Unit including cable (6 feet)
- Control Unit Brackets
- Input Fuses (supplied loose)
- Fuse Holder (supplied loose)
- Control Label (supplied loose)
- Ground Fault Current Transformer

Pre-Installation Planning

This drive has been tested in accordance with UL508. The drives are suitable for use on a circuit capable of delivering not more than 42,000 rms Amperes, 500 Volts maximum. When output chokes are supplied, all units are suitable for use on a circuit capable of delivering not more than 65,000 rms Amperes, 500 Volts.

The ACH 502 is supplied with fast acting semiconductor fuses with an interrupting rating of 200,000 rms symmetrical Amperes.

Careful planning is required to insure proper operation of the ACH 504. The information provided in this chapter includes all dimensions, cooling requirements, and wiring information.

Figure 4-1 shows the dimensional drawings of the ACH 504 Inverter Module and Figure 4-3 shows the dimensional drawings of the ACH 504 Control Unit. Figure 4-2 shows the foot print dimensional drawing of the Inverter Module. Table 4-1 gives the approximate weights of the Inverter Module. Table 4-2 gives the dimensions of the Inverter Module.

Figure 4-1 shows the dimensions of the Inverter Modules. Dimensions marked with letters and numbers are found in Table 4-2. Numbers are in inches (mm).

Figure 4-1 Inverter Module Dimensions

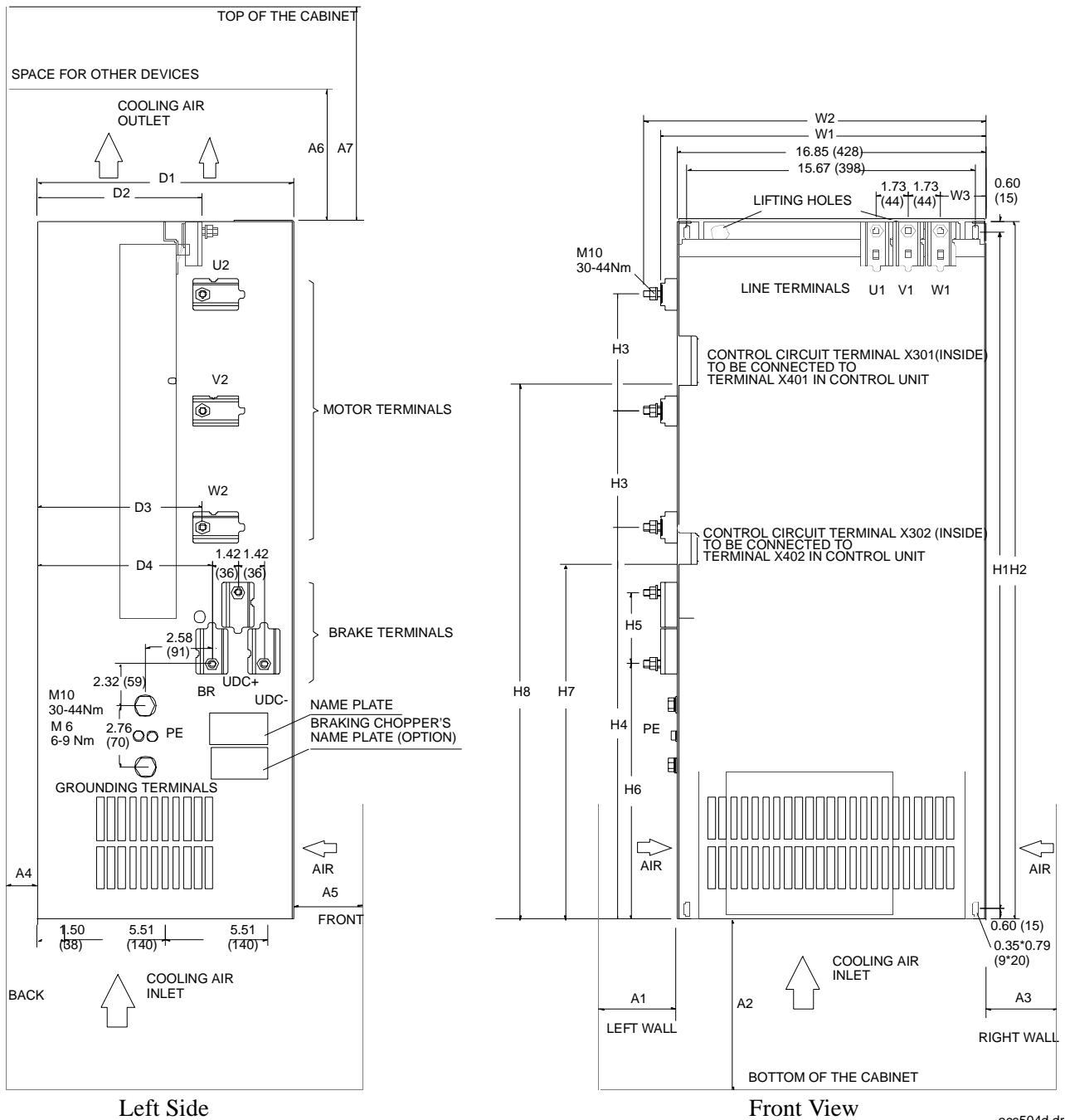

acs504d.dr

Table 4-1 ACH 504 Inverter Module Weights

	R6	R7	R8	R9
Weight (lb)	137	196	278	364
Weight (kg)	62	89	126	165

Table 4-2 shows the dimensions of the Inverter Modules.

Table 4-2 ACH 504 Inverter Module Dimensions

Code	R6		R7		R8		R9	
	mm	in	mm	in	mm	in	mm	in
H1	675	26.57	959	37.76	1255	49.41	1608	63.31
H2	705	27.76	989	38.94	1285	50.59	1638	64.49
H3	125	4.92	165	6.50	205	8.07	265	10.43
H4	390	15.35	557	21.93	720	28.35	928	36.54
H5	101	3.98	101	3.98	101	3.98	99	3.90
H6	214	8.43	363	14.29	538	21.18	717	28.23
H7	350	13.78	535	21.06	775	30.51	1080	42.52
H8	570	22.44	755	29.72	994	39.13	1300	51.18
W1	451	17.76	451	17.76	482	18.98	482	18.98
W2	473	18.62	473	18.62	512	20.16	512	20.16
W3	50	1.97	64	2.52	50	1.97	50	1.97
D1	385	15.28	385	15.28	415	16.34	415	16.34
D2	228	8.98	228	8.98	260	10.24	260	10.24
D3	229	9.02	229	9.02	259	10.20	259	10.20
D4	242	9.53	242	9.53	272	10.71	272	10.71
A1 – A7	Refer to Table 4-3							

Figure 4-2 shows the footprint of the Inverter Modules.

Figure 4-2 Inverter Module Footprint

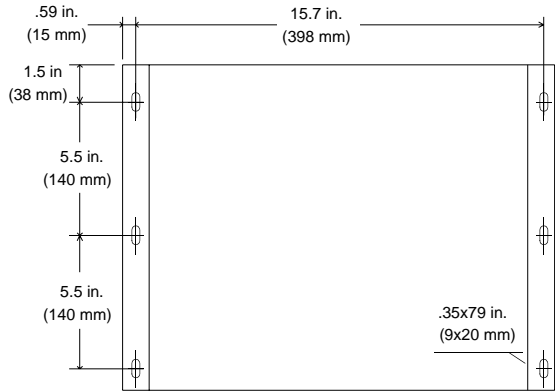

acs504ft.drw

Figure 4-3 shows the dimensions of the Control Unit. The control unit can be mounted inside the enclosure per the illustration below. The control unit is also supplied with two brackets to allow it to be mounted to the door of the enclosure. Refer to Figure 4-4 for an example. Figure 5-5 shows the dimensions of the window required and the dimensions required to mount the brackets in the correct location with respect to the window.

Figure 4-3 Control Unit Dimensions

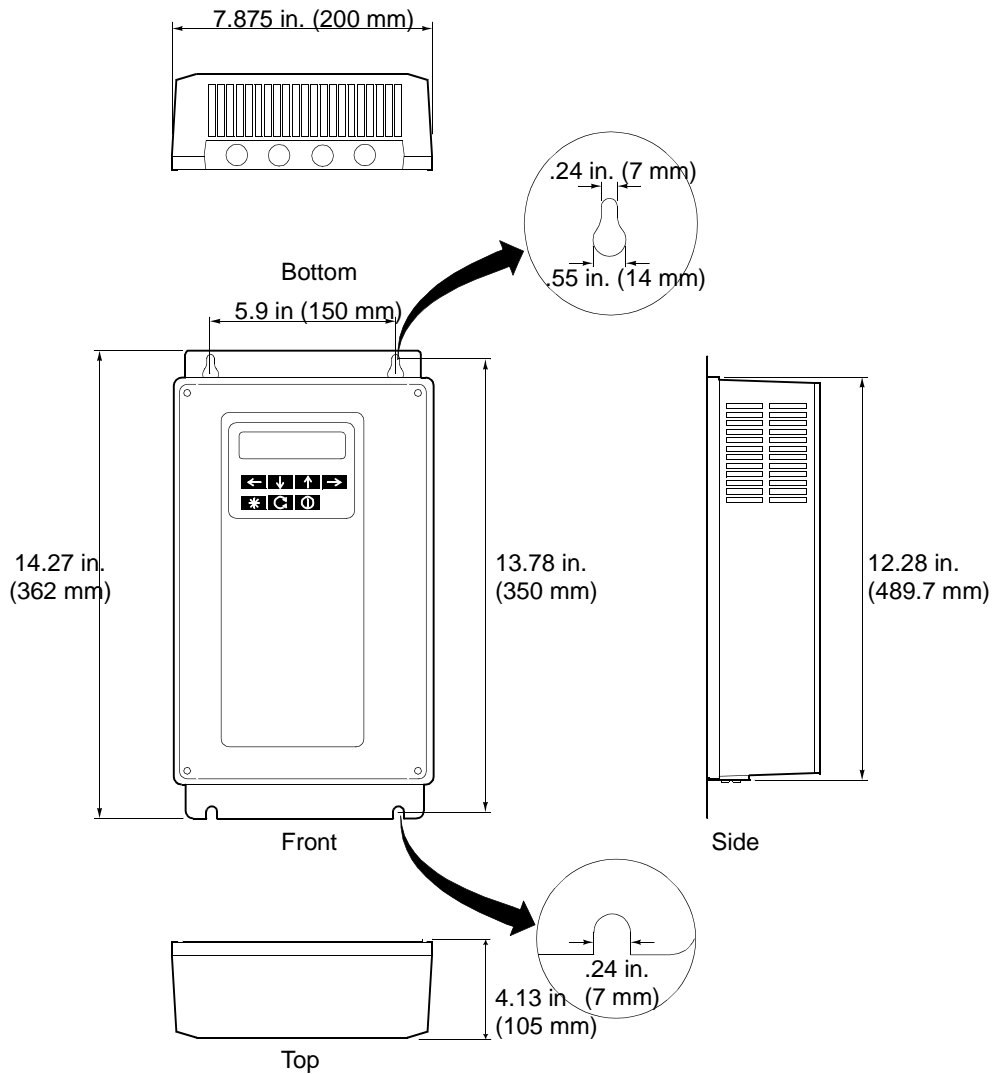

Figure 4-4 Example of Control Box Mounting

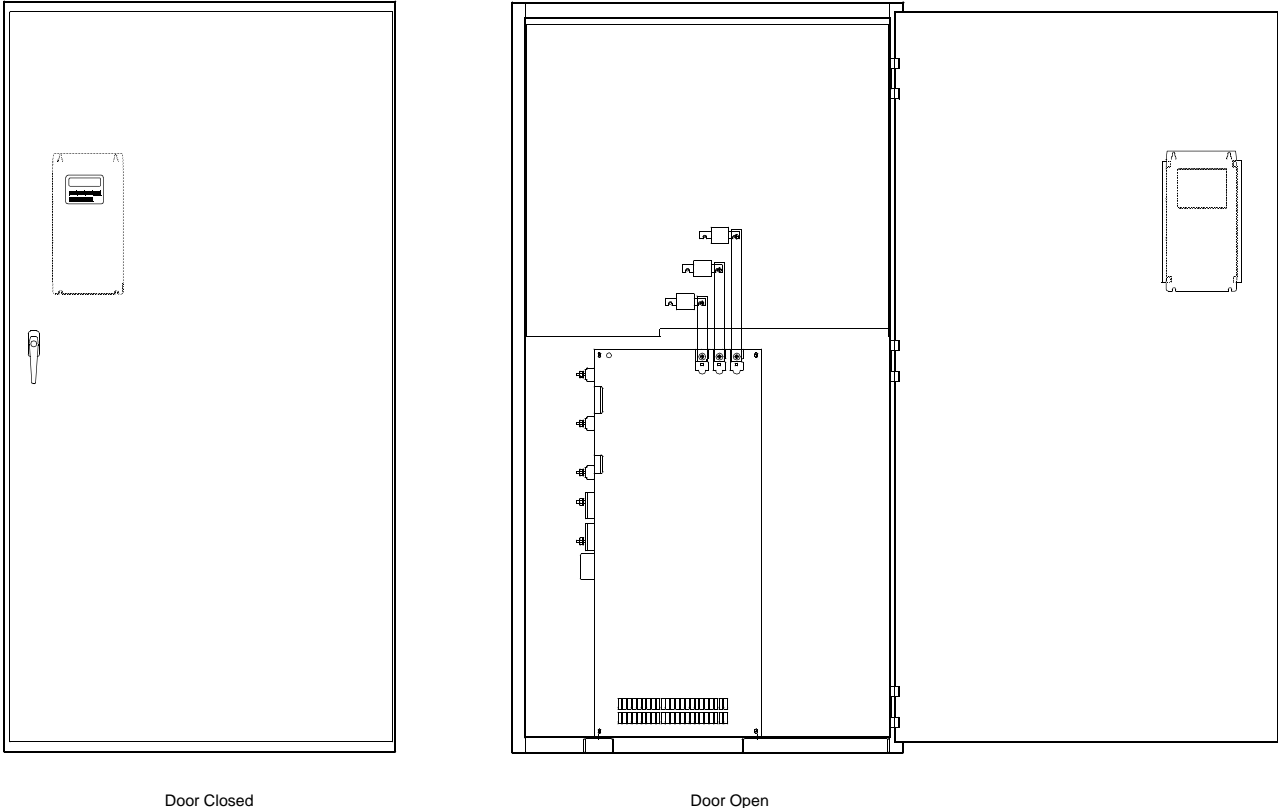

Figure 4-5 Mounting Bracket location in relation to window cut-out

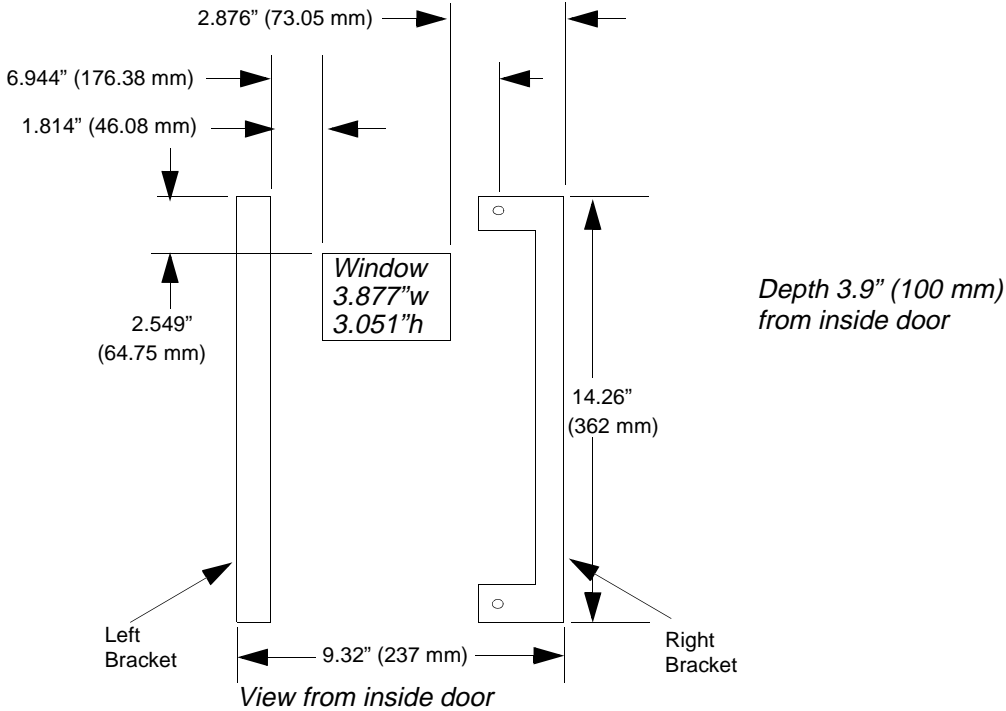

Table 4-3 shows power losses and cooling air volumes with free space requirements for ACH 504 Inverter Modules.

Table 4-3 ACH 504 Cooling Requirements

Drive Type	Losses	Air Volumes		Free Space Requirements								Opening Areas		
	Watts	Unit	Volume	Unit	A1	A2	A3	A4	A5	A6	A7	Unit	Inlet	Outlet
ACH 504-060-4	1750	m ³ /hr	300	mm	150	100	50	100	-	150	400	cm2	600	800
		CFM	177	in.	6	4	2	4	-	6	16	sq in.	93	124
ACH 504-075-4	2500	m ³ /hr	570	mm	150	100	50	100	-	150	400	cm2	800	1000
		CFM	335	in.	6	4	2	4	-	6	16	sq in.	124	155
ACH 504-100-4	3000	m ³ /hr	570	mm	150	100	50	100	-	150	400	cm2	800	1000
		CFM	335	in.	6	4	2	4	-	6	16	sq in.	124	155
ACH 504-125-4	3500	m ³ /hr	690	mm	150	-	50	100	50	150	400	cm2	1000	1500
		CFM	406	in.	6	-	2	4	2	6	16	sq in.	155	233
ACH 504-150-4	4250	m ³ /hr	690	mm	150	-	50	100	50	150	400	cm2	1000	1500
		CFM	406	in.	6	-	2	4	2	6	16	sq in.	155	233
ACH 504-200-4	5250	m ³ /hr	950	mm	150	-	50	100	50	150	400	cm2	1200	1800
		CFM	559	in.	6	-	2	4	2	6	16	sq in.	186	279
ACH 504-250-4	6500	m ³ /hr	950	mm	150	-	50	100	50	150	400	cm2	1200	1800
		CFM	559	in.	6	-	2	4	2	6	16	sq in.	186	279
ACH 504-300-4	8000	m ³ /hr	1350	mm	150	-	50	100	50	150	400	cm2	1400	2000
		CFM	795	in.	6	-	2	4	2	6	16	sq in.	217	310
ACH 504-350-4 and 400-4	10000	m ³ /hr	1350	mm	150	-	50	100	50	150	400	cm2	1400	2000
		CFM	795	in.	6	-	2	4	2	6	16	sq in.	217	310

Figure 4-6 shows the cooling requirements of the ACH 504.

Figure 4-6 ACH 504 Cooling Requirements (side view)

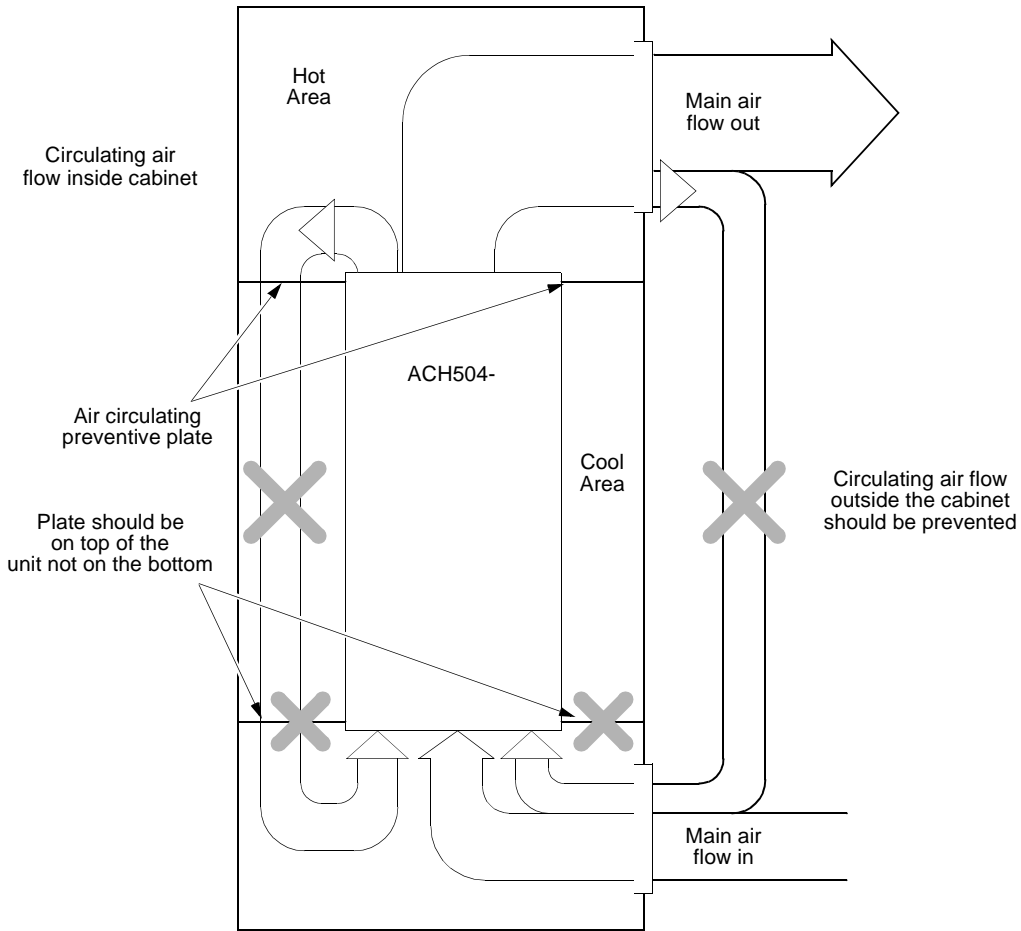

Environment

Inverter Modules

The Inverter Modules are provided with one or more cooling fans which are located on the bottom of the unit.

The maximum allowed ambient temperature, the temperature of the air entering the unit, is 104°F (40°C).

The cooling air must be clean and free from corrosive agents (according to ISA G1). When necessary the required cooling should be arranged by using specially filtered air.

The maximum total power losses of the modules and required cooling air volumes with free space requirements are shown in Table 4-3. For dimensional reference for the free space around the module, see Figure 4-1.

Included in Table 4-3 are recommendations for total open areas in the enclosure walls or door for cooling air inlet and outlet. If the total open areas are smaller or if the air path is very curved, the cooling capacity may be reduced due to reduced air flow.

The losses shown in the preceding table occur when the output current is I_{NSQ} and input current is I_{INSQ} . The temperature rise of the cooling air with these air volumes and losses is below 64°F (18°C).

Note: Dimension A7 is given with the assumption that the air exhaust is on top part of the door or side walls. This dimension may be reduced if the opening is on the roof of the cabinet.



GENERAL WARNING! When planning or inspecting the installation of ACH 504, pay special attention to the cooling air flow. Prevent the air from circulating from the outlet of the unit back to the inlet. Improper layout and inadequate channelling may lead to re-circulating air flow and excessive temperature rise within the enclosure. It may be necessary to install a horizontal baffle at the Inverter Module top level to keep the cool and warm air separate.

If the cooling air contains dust, clean the cooling surfaces of the unit regularly using compressed air and a brush. If there are filters at the air inlet of the enclosure, check their condition regularly and replace if needed.

If the cooling ability is reduced too much or if the ambient temperature exceeds 104°F (40°C), the thermal protection of the drive will operate causing an overtemperature warning and eventual tripping. The tripping temperature of the heatsink is 185°F (85°C). The drive can be started again when the temperature of the heatsink is below 167°F (75°C). (A faster way to start would be to disconnect the power, wait for the display to turn off, and power up again.)

The temperature of the heatsink can be read from the control panel display.

The temperature difference between the heatsink and ambient is an indication of the prevailing cooling conditions and can be utilized in preventive maintenance or in installation inspection. When the ACH 504 has been running at I_R for more than an hour, the difference should be less than 77°F (25°C). When the ACH 504 has been running at I_{RSQ} (f_{OUT} at 60Hz) for more than an hour, the difference should be less than 86°F (30°C).

Note: When planning or inspecting the installation of your ACH 504, pay special attention to the cooling air flow. Do not let the air circulate from the outlet of the drive to the inlet. This is especially important when you install a module in an area where improper lay-out and inadequate channelling may lead to re-circulating air flow and excessive temperature rise within the cubicle.

Control Unit

When planning the installation of the Control Unit in an enclosure, ensure that the temperature of the air surrounding the Control Unit does not exceed 122°F (50°C). Do not block the openings on the cover of the unit. Direct the warm exhaust air away from the Inverter Module so that it does not heat the Control Unit.

Power Wiring

Input and Output Power Wiring

Four conductors (three phase plus a ground wire) are required for the input and output wiring. Use copper conductor rated for 167°F (75°C). Input and output conductors and branch circuit protection must be sized to local codes.



WARNING:

- Do not connect or disconnect input or output power wiring, or control wires, when power is applied.
 - Never connect line voltage to drive output Terminals U₂, V₂, and W₂ (T₁ T₂, T₃).
 - Do not make any voltage tolerance tests (Hi Pot or Meggar) on any part of the unit. Disconnect motor wires before taking any measurements in the motor or motor wires.
 - Make sure that power factor correction capacitors are not connected between the drive and the motor.
-

Figure 4-7 and Figure 4-8 show the connections of the ACH 504.

Figure 4-7 ACH 504 Input and Output Power Connections

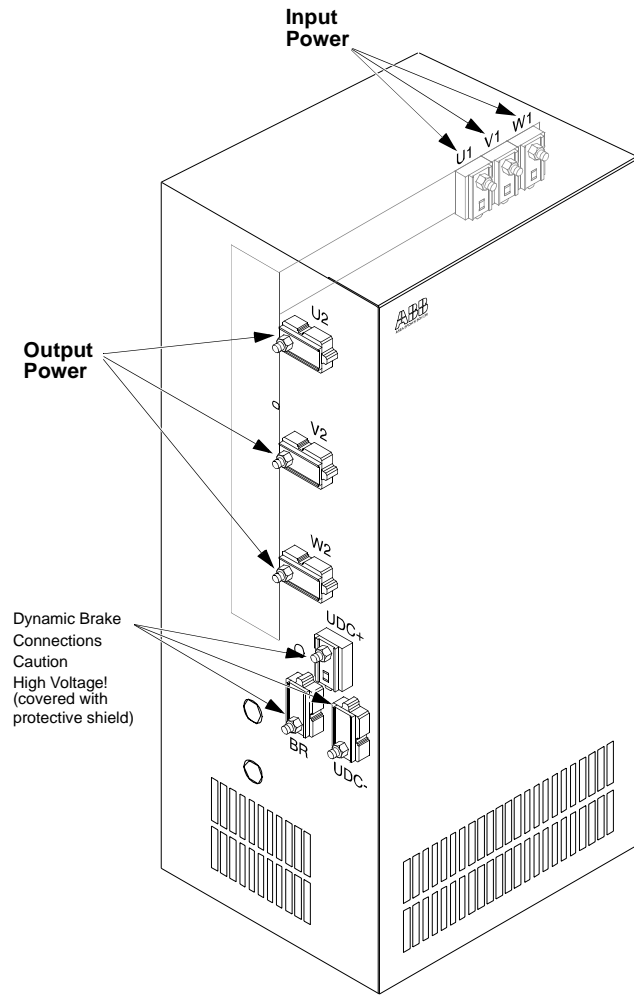
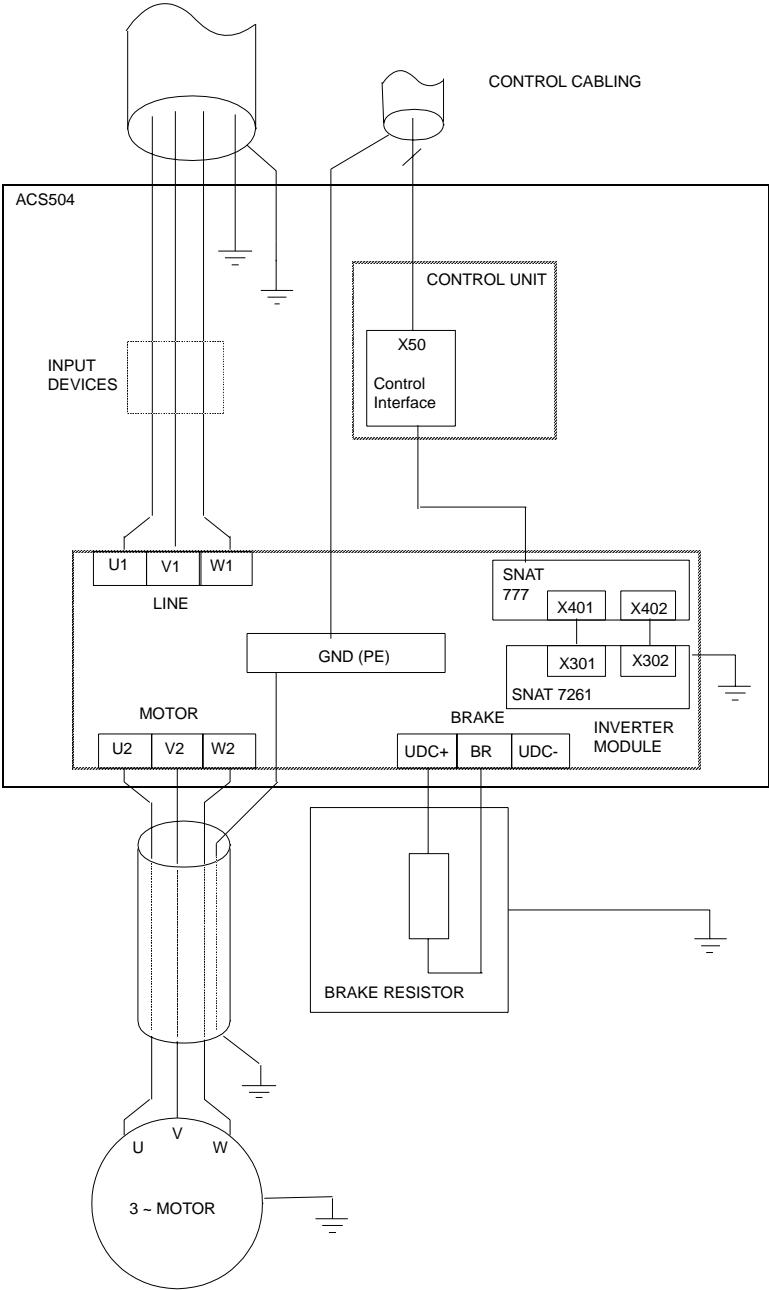

Figure 4-8 ACH 504 Connections



acs504cn.drw



GENERAL WARNING! When retrofitting an old motor with ACH 504, make sure there is no other circuitry connected to the motor. In particular, remove power factor correction capacitors and star/delta starters.

The terminal sizes and tightening torques of the power terminals are shown in Table 4-4, which also includes minimum current ratings and maximum I²t ratings for the input fuses to be used with the module (see page 3-4 for fuse types).

Check that the supply capacity is adequate for the drive (P_R or P_{RSQ}).

Table 4-4 ACH 504 Electrical Specifications

Drive Type	Power terminals U ₁ , V ₁ , W ₁ and U ₂ , V ₂ , W ₂			Ground terminal (PE)			Fuse Ratings		
	Size	Torque in Nm	Torque in lb-in.	Size	Torque in Nm	Torque in lb-in.	A	kA ² s	V
ACH 504-060-4	M10	30 – 44	260 – 380	M10	30 – 44	260 – 380	160	16	660
ACH 504-075-4	M10	30 – 44	260 – 380	M10	30 – 44	260 – 380	200	28	660
ACH 504-100-4	M10	30 – 44	260 – 380	M10	30 – 44	260 – 380	200	28	660
ACH 504-125-4	M10	30 – 44	260 – 380	M10	30 – 44	260 – 380	400	105	660
ACH 504-150-4	M10	30 – 44	260 – 380	M10	30 – 44	260 – 380	400	105	660
ACH 504-200-4	M12	50 – 75	435 – 650	M10	30 – 44	260 – 380	550	190	660
ACH 504-250-4	M12	50 – 75	435 – 650	M10	30 – 44	260 – 380	550	190	660
ACH 504-300-4	M12	50 – 75	435 – 650	M10	30 – 44	260 – 380	700	405	660
ACH 504-350-4	M12	50 – 75	435 – 650	M10	30 – 44	260 – 380	700	405	660
ACH 504-400-4	M12	50 – 75	435 – 650	M10	30 – 44	260 – 380	700	405	660

Precautions with Motor Cable

Install the motor cable away from other cable routes. Avoid parallel runs with other cables.



WARNING! The brake control terminals carry a dangerous DC voltage (>600V). No device other than an ABB Drives dynamic braking device may be connected to the UDC+, BR, and UDC- terminals.

Connecting the Control Unit to the Inverter Module

The cable coming out of the Control Unit is to be connected to connector X604 on the Inverter Module. The connector must be secured with the thumb screws. The cable provided is 6 feet long, and should not be extended.

The yellow/green grounding wire that is connected to one of the PE terminals on the left side of the Inverter Module is also to be connected to the Control Unit Chassis (PE2).

Connecting the Ground Fault Current Transformer

The ACH 504 is supplied with a current transformer (CT) to provide the ground fault protection. This CT should be installed on the input of the drive by running all three line wires through the CT (do not run the ground wire through the CT). The polarity of the CT is important. The current should flow

from the side labeled H1 to the side labeled H2.

The wires on the CT should be connected to the grey cable on the left side of the inverter module. The wires should be connected as follows: black - black; white - clear. The shield is connected at the drive end, and should not be connected at the CT end. Avoid running the signal wires parallel to the power wires.

Note: Polarity is critical in this installation. Ensure that the WHITE lead from the CT is connected to X1001:2 and the BLACK lead is connected to X1001:1 on SNAT7670EFS card.

Checking the Motor Insulation

Do not make insulation checks on the ACH 504 unless there is reason to suspect an isolation failure. Every unit has been tested for isolation between main circuit and chassis (2500 VAC for 1 minute) at the factory.

Before proceeding with the insulation resistance measurements, make sure that the ACH 504 is disconnected from the input line and then disconnect the output conductors from terminals U₂, V₂ and W₂.

Check that the motor cable is disconnected from the motor.

Measure the insulation resistance in the motor. The voltage range of the insulation resistance meter must be at least equal to the input line voltage but not exceeding 1000 V. The insulation resistance must be greater than 1 Mohm.

Measure the insulation resistance of the output conductors between the phases and between each phase and ground. The insulation resistances must be greater than 1 Mohm.

Control Connections

Available Control Locations

The available control locations for the ACH 504 are the:

- ACH Keypad located on the front of the drive.
- X50 screw terminals on the Control Interface Card SNAT-759.

Figure 4-9 shows the control interface card SNAT-759 with terminal and control locations.

Figure 4-9 SNAT-759 Connections

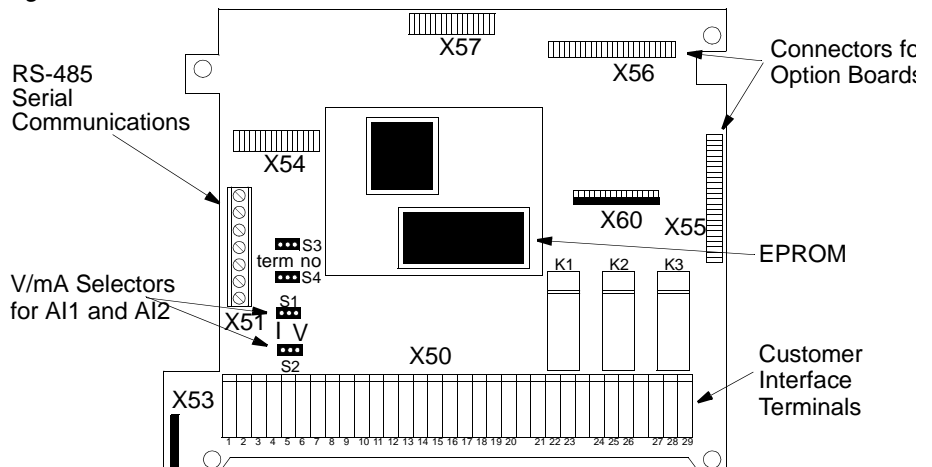

External control devices, for example a DDC or remote operator devices, are connected to Terminal Block X50 according to the connection diagram of each Application macro or according to the programming of the parameters in Main 10, Control Connections. The connection diagrams of Application macros are presented in the *ACH 500 Adjustable Frequency AC drives 2 to 350 HP Programming Manual Including Application Macros*. The X50 connection diagram based on factory settings is presented in Figure 4-9 (Control Interface Card SNAT-759 connections). The terminal functions can be altered by means of parameter settings.

X50 Terminal Block X50 can accept wire sizes from 16 – 22 AWG. All connections to terminals X50:1 to X50:20 should be made with shielded cables.

X50:2, 4, 6, 8, 18, and 20 are circuit common. They are optically isolated from the power line potential, and from chassis ground by a 10 megohm resistor. The common points are not isolated from each other.

Potentiometer A manual speed potentiometer is connected to the reference at X50:1 (+ 10 VDC) and X50:2 (common), and to one of the analog inputs.

Analog Inputs There are two analog inputs. AI1 is on terminals X50:3 and X50:4. AI2 is on X50:5 and X50:6.

The analog inputs can accept a voltage signal (0 – 10 VDC) or a current signal (0 – 20 mA), as selected by jumpers S1 and S2 (S1 for AI1 and S2 for AI2).

The jumper is placed in the “V” position for voltage and the “I” position for current. Figure 4-10 shows jumper positions. Orientation may vary with different versions of the control interface board.

Figure 4-10 Jumper Positions

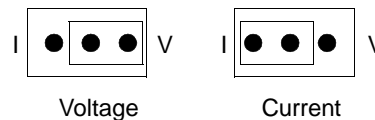

Auxiliary 24 VDC An auxiliary +24 VDC supply is available on terminals X50:7 and X50:8. This supply can drive auxiliary devices whose total current draw is less than 200 mA.

Digital Inputs There are six digital inputs, DI1 through DI6 on terminals X50:11 through X50:16 respectively. The digital inputs use 24 VDC logic from terminal X50:10, and are active high.

Analog Outputs There are two analog output signals. AO1 is on terminals X50:17 and X50:18. AO2 is on X50:19 and X50:20. These signals are 0 – 20 mA (or 4 – 20 mA), and can operate into a maximum 500 ohm load.

Digital (Relay) Outputs

There are three relay outputs which are each Form C. Relay RO1 is on terminals X50:21, X50:22, and X50:23; Relay RO2 is on terminals X50:24, X50:25, and X50:26; Relay RO3 is on terminals X50:27, X50:28, and X50:29.

The first terminal for each relay is the normally closed terminal (NC), the second is the common, and the third is the normally open (NO).

Maximum Switching Voltage: 300 VDC / 250 VAC

Maximum Switching Current/Power: 8 A @ 24 VDC, 0.4 A @ 250 VDC, or 2000 VA @ 250 VAC

Maximum Continuous Current: 2 A rms

If the relay outputs are used to control inductive loads, such as the coils of relays or contactors, some form of noise suppression must be provided at the load. This is to reduce the electrical noise that could interfere with the electronics in the drive, as well as increase the life of the contacts in the relay.

AC coils should be suppressed with an MOV (metal oxide varistor) or a Series-Connected RC (resistor capacitor) network, as illustrated below:

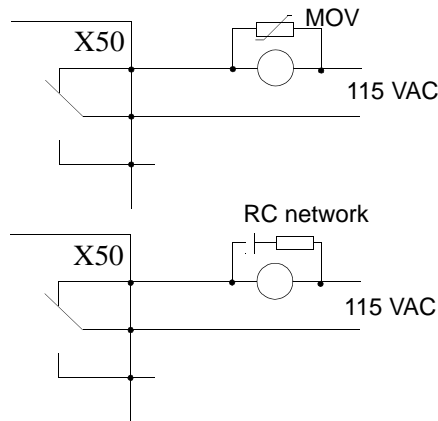

MOV should be rated 120 VAC - 240 VAC for 115 VAC circuits, 240 VAC - 320 VAC for 230 VAC circuits, minimum 10 joules. Values for the RC Network vary, as they effect the opening and closing time. Contact the contactor manufacturer for recommended values.

DC coils should be suppressed with a diode, although this is not required because of the small amount of noise generated by these type of circuits. If a diode is used, it should have a voltage rating greater than or equal to the supply voltage, and be connected as shown below:

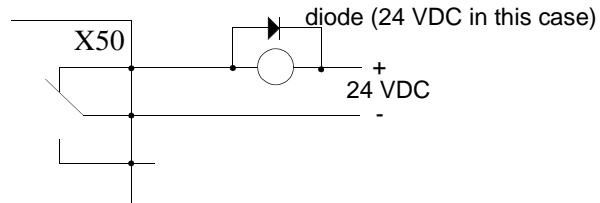

Control Interface Card Connections

Figure 4-11 shows Control Interface connections for factory-set parameter values, and indicates proper connection of a Hand/Off/Auto switch.

Figure 4-11 Control Interface Connections and Parameter Values

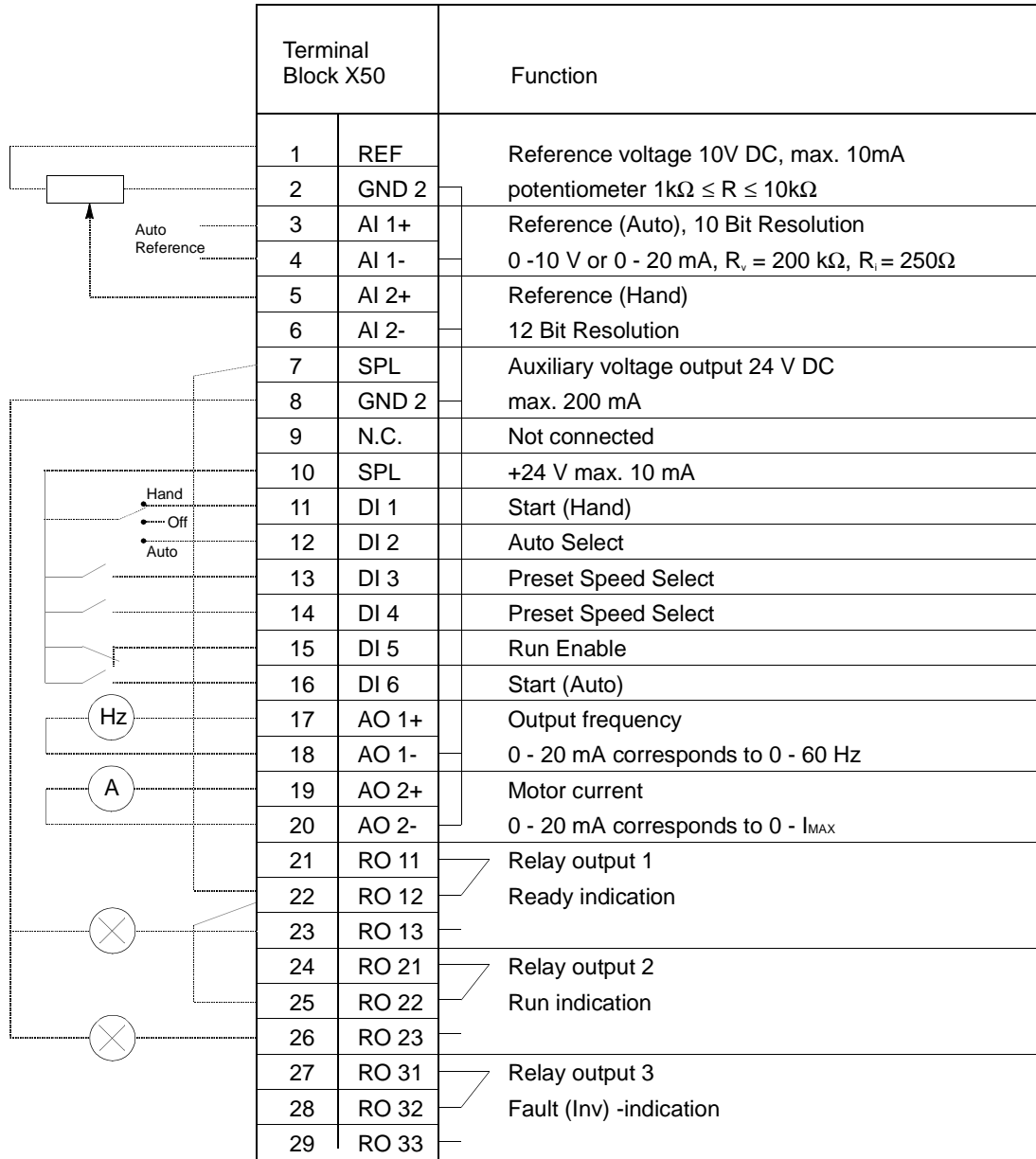

Chapter 5 – Start-up Procedure

This chapter explains how to inspect the installation and how to start-up the ACH 502. Prerequisite information required for start-up was provided in *Chapter 2 – Overview of the ACH 502/504*.

Safety Precautions

Before start-up, observe the following:

The components inside the converter module are at DC Bus potential ($1.35 \times V_{IN}$) when the ACH 502 is connected to supply voltage. This voltage is extremely dangerous and can cause death or serious injury.

When the supply voltage is disconnected from the input terminals U_1 , V_1 , W_1 (L_1 , L_2 , L_3), it will take about five minutes before the DC Bus capacitors are discharged to a safe voltage.

To ensure that the voltage level is safe, measure the voltage between positive (+) and negative (-) DC Bus Terminals UDC+ and UDC- (refer to Figure 4-8). Meter must be rated for 1000 VDC. Also measure between UDC+ and chassis ground.

The Control Interface Card and Option Cards are isolated from the main circuit, but dangerous voltages may be present at relay contact terminals. Always check for high voltage at Terminals X50:21 – 29 before working on the Control Interface or Option Cards.



WARNING! When the ACH 502 is connected to the line power, the Motor Terminals U_2 , V_2 , and W_2 (T_1 , T_2 , T_3) and the Brake Terminals UDC+, UDC-, and BR are live even if the motor is not running. Do not make any connections when the ACH 502 is connected to the line. Disconnect and lock out power to the drive before servicing the drive. Failure to disconnect power may cause death or serious injury.

Figure 5-1 shows the start-up checklist.

Figure 5-1 Start-up Checklist

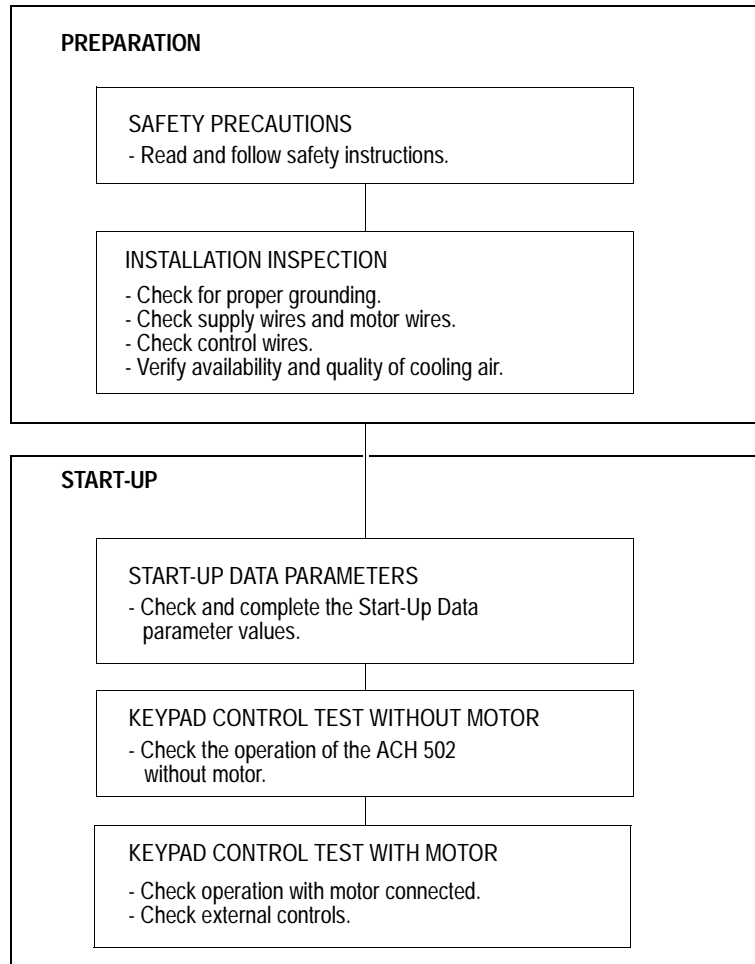

Installation Inspection

Inspect the mechanical and electrical installation of the ACH 502 for compliance with the prevailing electrical installation regulations and codes.

Note: Do not connect the motor wires before proceeding with the Keypad Control Test, Motor Disconnected. Refer to Keypad Control Tests in this chapter.

After installation, inspect the following:

- Grounding of the ACH 502 and the motor.
- Supply and motor wires (selection of the wire size, connections).
- Control cables (connections, wire shields grounding, location as far as possible from the power wires).
- Quantity and quality of cooling air for the ACH 502.
- Verify that it is safe to run the motor.
- Connect the ACH 502 to supply voltage. Check that the voltage between $L_1 - L_2$, $L_2 - L_3$, and $L_1 - L_3$ ($U_1 - V_1$, $U_1 - W_1$, and $V_1 - W_1$) is $V_N \pm 10\%$.

Start-up Data Parameters

Power up the ACH 502. The display shows Operating Data Parameter 1 (Output Frequency). Before proceeding with the start-up, check and complete the Start-up Data Parameter values. Do not change parameters at this time except as described in the following steps.

While viewing Parameter 1 (Output Frequency) press and hold [*], then press [Right Arrow]. The display shows Parameter A (Language) in Setting mode.

- A LANGUAGE** Press [Up Arrow] or [Down Arrow] to select your preferred language. The ACH 502 displays all information in the language you select. Press [*] to confirm the selection and move to the next parameter. The available languages are: English, German, Italian, Spanish, Dutch, French, Danish, Finnish, and Swedish.
- B APPLICATIONS** Leave this in the factory setting to perform the start-up procedure. If anything other than HVAC displays, press [Up Arrow] or [Down Arrow] to change the parameter to HVAC. Press [*] to confirm the selection and move to the next parameter.
- C APPLIC. RESTORE** This parameter restores all parameters of the current application to factory-set parameter values. Set this to YES by pressing [Up Arrow]. Press [*] to confirm the selection and move to the next parameter.
- D SUPPLY VOLTAGE** This parameter offers choices of 440, 460, 480, and 500 VAC for 480-volt units.
- Press [Up Arrow] or [Down Arrow] to select the voltage value matching line voltage providing power to your ACH 502. Press [*] to confirm the selection and move to the next parameter.
- E USER DISPLAY SCALE** This parameter is used to set the scaling factor for Operating Data Parameter 2 (Speed). When set to 0, the speed display will show RPM. When set to 100, the speed display will show %. When set to any other value from 0 – 10000, the display will show this value (minus slip unless slip compensation is ON) when the output frequency is at the frequency set by Start-up Data Parameter I (Motor Base Frequency).
- Press [Up Arrow] or [Down Arrow] to set the desired value of the speed display. Press [*] to confirm the selection and move to the next parameter.
- F MOTOR CURRENT -FLA** This parameter matches the ACH 502 to the rated motor current, adjustable between 0 and 1000 amps. The drive uses this parameter for motor overload protection and current (amperage) information displays.
- Press [Up Arrow] or [Down Arrow] to select the current (amperage) value for your motor. Press [*] to confirm the selection and move to the next parameter.

G MOTOR POWER This parameter matches the motor rated power, adjustable between 0.7 hp and 1340 hp. The drive uses this parameter for motor overload and kWh information displays. The left key switches the display between hp and kWh. To change the display, press and hold the left key for two seconds.

Press [Up Arrow] or [Down Arrow] to select the motor power value for your motor. Press [*] to confirm the selection and move to the next parameter.

H MOTOR POWER FACTOR This parameter matches the motor power factor (at rated speed and load on sinusoidal power), adjustable between 0.10 and 1.0. The drive uses this parameter for motor torque and power information displays.

Press [Up Arrow] or [Down Arrow] to select the motor power factor value for your motor. Press [*] to confirm the selection and move to the next parameter.

I MOTOR BASE FREQUENCY This parameter is used to set the designed frequency of the motor, adjustable from 30 Hz to 500 Hz in 10 Hz increments. Changing this value will automatically set the Field Weakening Point (FWP) to the same value.

Press [Up Arrow] or [Down Arrow] to select the base frequency value for your motor. Press [*] to confirm the selection and move to the next parameter.

J MOTOR BASE R.P.M. This parameter is used to set the nameplate speed of the motor and is adjustable from 200 to the maximum 2 pole motor speed based on Start-up Data Parameter I (Motor Base Frequency).

Press [Up Arrow] or [Down Arrow] to set the motor nameplate speed value for your motor. Press [*] to confirm the selection and move to the next parameter.

K MOTOR NOM. VOLTAGE The default is 460 V for 480-volt units. Changing this parameter automatically changes the Maximum Output Voltage.

Press [Up Arrow] or [Down Arrow] to select the motor rated voltage for your motor. Press [*] to confirm the selection and return to Operating Data Parameter 1 (Output Frequency).

Keypad Control Tests

Motor Disconnected from the ACH 502

After setting the Start-up Data parameters, test the drive as follows:

1. Disconnect and lock out power from the ACH 502. Wait at least five minutes after disconnecting power. Verify that the DC Bus voltage is at a safe level by measuring the voltage between positive (+) and negative (-) on Brake Terminals UDC+ and UDC-. Check for zero volts at Terminals X50:21 – 29 before continuing.
2. Disconnect the motor from the ACH 502.
3. Power up the ACH 502.
4. Press [Start/Stop] to issue a start command. The Run Status indicator on the LCD Display displays the Start (I) symbol.

5. Press [*] to enter setting mode. Press [Up Arrow] until the frequency display shows 60 Hz, then press [*] to enter the value.
6. Press [Up Arrow] or [Down Arrow] to scroll through and check the Operating Data parameters. Check that Operating Data Parameter 7 (Output Voltage) is equal to the input voltage. Verify that Operating Data Parameter B (Motor Current) is less than 3% of the drive rated current (I_R).

If the drive operates according to these steps, disconnect and lock out power to the ACH 502 to prepare for the next test.



WARNING! Wait at least five minutes after disconnecting power from the drive before you attempt to service the drive. Bus capacitors in the intermediate DC circuit must discharge before servicing the drive. Check for zero volts at Terminals TB1:21 – 29, UDC+, and UDC-. Your measuring meter must be rated for 1000 VDC. Failure to check voltages may result in death or serious injury.

If the drive does not operate according to these steps, refer to *Chapter 6 – Fault Tracing* in this manual for additional information.

Motor Connected to the ACH 502

After successfully testing the drive with the motor disconnected, continue testing the drive as follows:

1. Disconnect and lock out power from the ACH 502. Check for zero volts at Terminals X50:21 – 29 and X2:(+) and (-) before continuing.
If a Bypass option is supplied, set the Drive Switch to NORMAL and the Bypass Switch to NORMAL.
2. Connect the motor to the ACH 502.
3. Power up the ACH 502.
4. Set Operating Data Parameter 10 (Keypad Ref 1) to 0.5 Hz.

CAUTION: Check motor rotation direction as soon as the motor begins to move. If motor rotation direction is critical and the motor does not run in the direction indicated by the Rotation Direction indicator on the ACH 502 LCD Display:

- Shut down the drive.
- Disconnect and lock out power to the drive.
- Wait five minutes.
- Check for zero volts at Terminals UDC+ and UDC-.

When the drive has reached zero volts, swap any two *motor output* wires at the Output Terminals. Incorrect motor rotation direction may cause equipment damage.

5. Press [Start/Stop] to issue a start command. The Run Status indicator on the LCD Display displays the Start (I) symbol.

6. Check the monitored values of Operating Data Parameters 1 – 8 for normal drive and motor operation.
7. Return to Operating Data Parameter 1 (Output Frequency).
8. Slowly increase the frequency value of Parameter 1. Verify that motor speed varies as frequency varies.
9. Increase the Parameter 1 frequency value to 60 Hz and return to Display mode.
10. Measure the output current in all three phases. The current should be balanced, and should not exceed the motor or drive rating.
11. If a Bypass option is supplied, check the motor rotation in bypass. Set the Bypass switch to BYPASS, then to TEST. If the motor turns in the wrong direction, swap any two *input* power wires.

If the drive operates according to these steps, your ACH 502 is ready to use with preset or modified macro adjustments.

If the drive does not operate according to these steps, refer to *Chapter 6 – Fault Tracing* in this manual.

Note: *If you plan to use an external control device for your drive, you must wire the control to the drive according to the wiring scheme of the macro you select.*

Refer to the *Chapter 2 – Overview of the ACH 502/504, Control Panel Operation* for more information on accessing and changing parameters.

Keypad Control vs. External Control

The ACH 502 can be controlled from the Control Panel keypad, or with the HOA switch and speed pot located on the front of the enclosure, or with an external control device. Refer to the *ACH 500 Adjustable Frequency AC Drives 3 to 350 HP Programming Manual Including Application Macros, Chapter 4 – Control Operation*, for additional information. The selection between KEYPAD and EXTERNAL is made through Operating Data Parameter 9 (Control Location).

KEYPAD R1 is a direct frequency reference, set by Operating Data Parameter 10 (Keypad Ref 1). KEYPAD PI goes through an application block, where it can be manipulated when the PI-controller is selected, set by Operating Data Parameter 11 (Keypad PI (REF 2)). Refer to the *ACH 500 Adjustable Frequency AC Drives 3 to 350 HP Programming Manual Including Application Macros, Chapter 4 – Control Operation*, for additional information.

External control devices, for example a DDC or remote operator devices, can be connected to Terminal Block TB1, when supplied, or Terminal Block X50. These control devices can be Analog or Digital. EXTERNAL selection will cause the ACH 502 to follow commands connected to X50 (or TB1), such as a manual speed pot, HOA switch, Automatic Start, and Speed Signals, etc. Refer to *Chapter 3 – ACH 502 Installation Instructions* or *Chapter 4 – ACH 504 Installation Instructions* for additional information.

Default Drive Parameters

Now that you have tested and started the drive using the Factory macro settings, check the Factory macro default drive parameters. Refer to the *ACH 500 Adjustable Frequency AC Drives 3 to 350 HP Programming Manual Including Application Macros* for additional information about Factory macro default settings.

ACH 502 external control wiring schemes vary according to the macro you choose and the parameter values you change. If you plan to change the ACH 502 macros or parameter values, and if you plan to use an external control device, refer to the *ACH 500 Adjustable Frequency AC Drives 3 to 350 HP Programming Manual Including Application Macros* for information on control wiring, application macros, and modifying macro parameters.

To complete the start-up, select the appropriate application macro, and make any necessary parameter changes. Connect all external wiring based on the configuration selected, and test all external interfacing.

Customizing Application Macro Parameters

At some point during the installation of your ACH 502 you may select one of the pre-set application macros closely suited to your application. You select application macros from Start-up Data Parameter B (Applications). You also may need to modify the macro to custom-fit your application. For example, if you select the HVAC macro for your application, the HVAC macro default for Start-up Data Parameter D (Supply Voltage) is 480 V. If your supply voltage is 460 V, you need to change this parameter in the macro accordingly.

To customize the macro for your application you must change certain parameter values. In each macro, certain parameters are more likely to be changed than other parameters, but the application determines which parameters, and in which macro, changes will be required.

Note: *If you plan to use an external control device for your drive, you must wire the control to the drive according to the wiring scheme of the macro you select. Refer to the ACH 500 Adjustable Frequency AC Drives 3 to 350 HP Programming Manual Including Application Macros for more information on specific macro external control wiring schemes.*

Refer to the *ACH 500 Adjustable Frequency AC Drives 3 to 350 HP Programming Manual Including Application Macros* for more information on accessing and changing parameters.

Note: *If you use RUN ENABLE Digital Input from the screw terminals, the keypad's START/STOP function becomes disabled until a run enable signal is present.*

Note: *The direction is fixed in FORWARD by Parameter 10.1.3 (Loc/Ext Direction) in the factory default settings for safety purposes. If the application requires reversing, change Parameter 10.1.3 accordingly.*

**Password Protection
(Parameter Lock)**

Parameter Lock prevents unauthorized persons from altering the parameters. When Parameter Lock is active the Setting mode cannot be selected and ACH 502 parameters can not be changed. The ACH 502 Parameter Lock can be controlled with the Keypad (Operating Data Parameter 20 (Parameter Lock)) or a digital input. Parameter 10.4.3 (Param. Lock Sel) (Keypad, DI1 – DI6) selects the control location. To activate the Parameter Lock, set operating Data Parameter 20 (Parameter Lock) to LOCKED xxx if the control location is the Keypad or activate the selected digital input if the control location is a DI setting.

The Parameter Lock control location is indicated in Operating Data Parameter 20 (Parameter Lock). Characters xxx after the parameter value (OPEN xxx , LOCKED xxx) indicate that the current control location is Keypad.

To open the Parameter Lock, you must enter the correct combination. The combination for all ACH 502 units is 358. When viewing Parameter Lock, enter setting mode and set the xxx to 358. Press [*] to open the Parameter Lock. Refer to the *ACH 500 Adjustable Frequency AC Drives 3 to 350 HP Programming Manual Including Application Macros, Chapter 4 – Control Operation*, for detailed setting instructions.

Chapter 6 – Fault Tracing

Warning and Fault Messages

The following tables provides explanations of the ACH 502 and ACH 504 warning and fault messages.

Warning messages of ACH 502/504

Warning message	Possible reason	Remedy
1 OVER TEMP	The heatsink temperature is > 149°F (>65°C). An OVER TEMP warning is normal if the ambient temperature and load are near the upper limits. If the ambient temperature and load are not near the upper limits, then the following should be checked: Restricted air flow caused by dust or inappropriate installation, overloading, or a component failure (fan, fuse, power semiconductors). If this warning comes at the start, it is possible that terminal X307 on the Main Circuit Interface Card is loose.	Check that ambient temperature is < 104°F (< 40°C). Check that the drive was not overloaded for a long time. Check the fan and air flow. Check the fuses on SNAT 7902 INP. Check that T61 primary and secondary connections are OK. Check the heatsink fins and remove any dust or dirt. If the fault persists, contact a service representative.
2 MOT STALL	Parameter 30.18.8 (Stall Func) is set to WARNING.	Refer to Fault 3 (Mot Stall).
3 MOTOR TEMP	Parameter 30.1.3 (Mot Temp Flt Func) is set to WARNING.	Refer to Fault 4 (Motor Temp).
6 UNDER LOAD	Parameter 30.1.10 (Underload Func) is set to WARNING.	Refer to Fault 7 (Under Load).
7 AI < MIN	Parameter 30.1.2 (AI < Min Func) is set to WARNING.	Refer to Fault 11 (AI < Min).
8 EEPROM WR	Parameter storing to the EEPROM has failed.	Try to store again. If warning occurs again, try to restore factory settings. If the warning persists, contact ABB Technical Support.

**Fault messages of
ACH 502/504**

Fault message	Possible reason	Remedy
1 START/STOP	The start/stop reference from Control Interface Card is different from the start/stop state of the Motor Control Card.	Check the connection between Control Interface and Motor Control Cards. If the fault persists, contact ABB Technical Support.
2 OVER TEMP	The heatsink temperature has been above 185°F (85°C) and has not fallen below 167°F (75°C). Restricted air flow caused by dust or inappropriate installation; overloading or a component failure (fan, power semiconductors). If the display shows a negative temperature, when the ambient (and heatsink) is obviously warmer, the thermostat S1 has probably opened (due to Rectifier bridge overtemperature). If this fault appears at start, it is possible that terminal X307 on Main Circuit Interface Card is loose.	Check that ambient temperature is < 104°F (< 40°C). Check that the drive was not overloaded for too long. Check the fan and air flow. Check the fuses on SNAT 7902 INP. Check that T61 primary and secondary connections are OK. Check heatsink fins, remove any dust or dirt. If the fault persists, contact a service representative. If the temperature display was negative, check the line fuses.
3 MOT STALL	The ACH 502/504 has determined that the motor is operating in the stall region. Refer to Parameter 30.1.10 (Stall Time/Freq). The motor is not turning because of increased load torque. Motor may be too small for the application.	Remove mechanical problem causing increased load torque. If the motor shaft is rotating and the motor is not overheating, increase stall limit parameters. Check dimensioning, use larger drive and motor if necessary.
4 MOTOR TEMP	The ACH 502/504 has determined that there is a high probability that the motor is overheated. Because the temperature rise is calculated from the motor current and not measured directly, the motor may be within temperature rise specification.	Check the motor temperature. If it is within temperature rise specification, increase Parameter 30.1.5 (Motor Load Curve) and/or Parameter 30.1.4 (Motor Therm Time) and restart. If the motor temperature is above rated temperature, improve motor cooling or resize the motor.
7 UNDER LOAD	The motor load has dropped below the supervision limit set by Parameters 30.1.12 and 30.1.13.	Remove mechanical problem causing underload. Check motor load cycle and increase Parameter 30.1.12 (Underload Time) or change Parameter 30.1.13 (Underload Curve).
8 OVERCURR1	The output current instantaneous value has exceeded 375% of I_N . Too short acceleration time relative to load inertia is the most common cause of an overcurrent trip. Also sudden shocks in the load torque may cause this trip. If the field weakening point is set too low or if there is too much IR-compensation, an overcurrent trip may follow. An oversized motor, a short circuit, or other hardware failure in the motor, motor cable, or in the drive itself may also cause this trip.	Check the load torque conditions and accelerating time. Make sure that there is no short circuit or ground fault in the motor circuit. See that there is no other load than the motor (especially capacitors) connected to the power output.
8 OVERCURR3	This trip originates from the supervisory circuits on the gate pulse channels on the Main Circuit Interface Card. An undervoltage at any of the gate pulse channels' auxiliary +/- 15 V supply will cause this trip.	If the fault persists after resetting, it is most probably due to undervoltage at a pulse channel. Replace the Main Circuit Interface Card. If the fault persists after starting the drive once, contact ABB Service. Do not try to restart the drive several times, since this may lead to other hardware failures.

Fault message	Possible reason	Remedy
9 OVER VOLT	DC bus voltage has exceeded 130% nominal voltage. Most common cause for this is overvoltage (static or transient) in the input line. Overvoltage can also result, when the motor runs as a generator in drives where the load inertia is extremely high and the deceleration time is set low.	Check the input line for static or transient overvoltages, e.g., generating loads or large power factor correction capacitors upstream. Use longer deceleration time or use coasting stop function if it is compatible with the application. If short deceleration time is needed, use Dynamic Braking Device.
10 UNDER V 1	DC bus voltage has gone below 60% of the nominal voltage. Most common reason for low voltage trip is failure in the input line, e.g., loss of one phase due to a fuse clearance. A sudden load spike or vibrations in the load may also cause this trip. Internal failure in the ACH 502/504 can cause this trip.	Check input line fuses and supply. If they are OK, an internal failure has occurred. Contact ABB Technical Support.
11 AI < MIN	Analogue input less than the minimum as set by Parameters 10.5.1 and 10.5.5.	Input reference has failed or control wire is broken. Check the reference circuit.
16 PWR RNGE	Power range programming does not match after replacing the Control Interface or the Main Circuit Interface Card.	Check the Matching Card which is on top of the Main Circuit Interface Card. Check that the start-up data is given accordingly for the new Control Interface Card. Remove power, wait one minute, then restore power. If the fault persists, contact ABB Technical support.
19 IN COMMS	Failure in serial communication within the Control Interface and/or Motor Control Cards.	Check the cabling between the Control Interface and the Motor Control Cards. If the fault persists, contact ABB Technical Support.
20 CON INT	This fault is related to components in the Control Interface Card.	Remove power, wait one minute, then restore power. If the problem persists, call ABB Technical Support.
21 MOT CONTX	This fault is related to components in the Motor Control Card or in the Converter Module.	The number replacing the X in the fault message conveys the following information: 1 = U_2 phase current measurement problem 2 = V_2 phase current measurement problem 3 = DC-voltage measurement problem 4 = Serial communication problem 5 = Power supply problem on SNAT 777 6 = Too high ripple content in DC-voltage, possibly caused by an input line fuse failure or phase loss/unbalance. Check these areas. Also make sure that the load is not vibrating. If the fault persists, check the Input Protection Card and/or rectifier modules. For faults 1 – 5, remove power, wait one minute, then restore power. If the problem persists, call ABB Technical Support. Record the specific fault code (X), you may be asked for it.
22 PAR REST	Parameter restoring error. Parameter checksum does not match.	Reset fault display. (The display is reset allowing the scrolling of parameters, but the fault is not reset.) Check all parameter settings or reset the factory settings. Remove power, wait one minute, then restore power and check that the fault has disappeared.

Fault message	Possible reason	Remedy
23 UNDER V 2	DC bus voltage does not rise over 80% of its nominal value ($1.35 \times V_{IN}$) in 5 sec. after connecting the input line. This fault message is also displayed if the Start command is active and voltage drops below 60% and does not increase above 80% within 40 sec.	Check input line fuses and supply. If they are OK, an internal failure has occurred. Contact ABB Technical Support.
24 GND FAULT	Current at start is more than 5% of the nominal current I_N . There may be a ground fault or a voltage source in the motor circuit. This message may also appear if the motor is switched from bypass to ACS 502/504 too quickly, so that the motor flux generates the current.	Disconnect the input line, wait 5 minutes and check that the DC-voltage is zero, then disconnect the motor cables and check the motor circuit isolations. If there is no ground fault, check the ACS 502/504. The running ground fault detection circuit is factory set to 2.5 amps by jumper S1 on the ground fault sensing card (SNAT 7670 EFS). The settings on the card are as follows: A - 2.5 A B - 5.0 A C - 7.5 A D - 10.0 A
	Ground fault circuit measured current greater than 2.5A. There may be a ground fault or a voltage source in the motor circuit.	

Other Fault Situations

There may be other fault situations that need to be corrected. For example, if nothing happens when power is applied to the ACH 502/504, refer to the following flowchart for assistance.

If parameter 20.4.10 (Voltage Limit) is set to YES, the internal logic of ACH 502/504 prevents starting the drive if the DC bus voltage is over 117% of its nominal value as derived from the Start-Up Data Parameter D (Supply Voltage). The limit for preventing is $1.17 \times 1.35 \times V_{IN}$. If in doubt, check these parameters and the DC bus voltage.

Figure 6-2 shows the troubleshooting procedure if the display is not activated when power is applied.

Figure 6-2 Troubleshooting Procedure

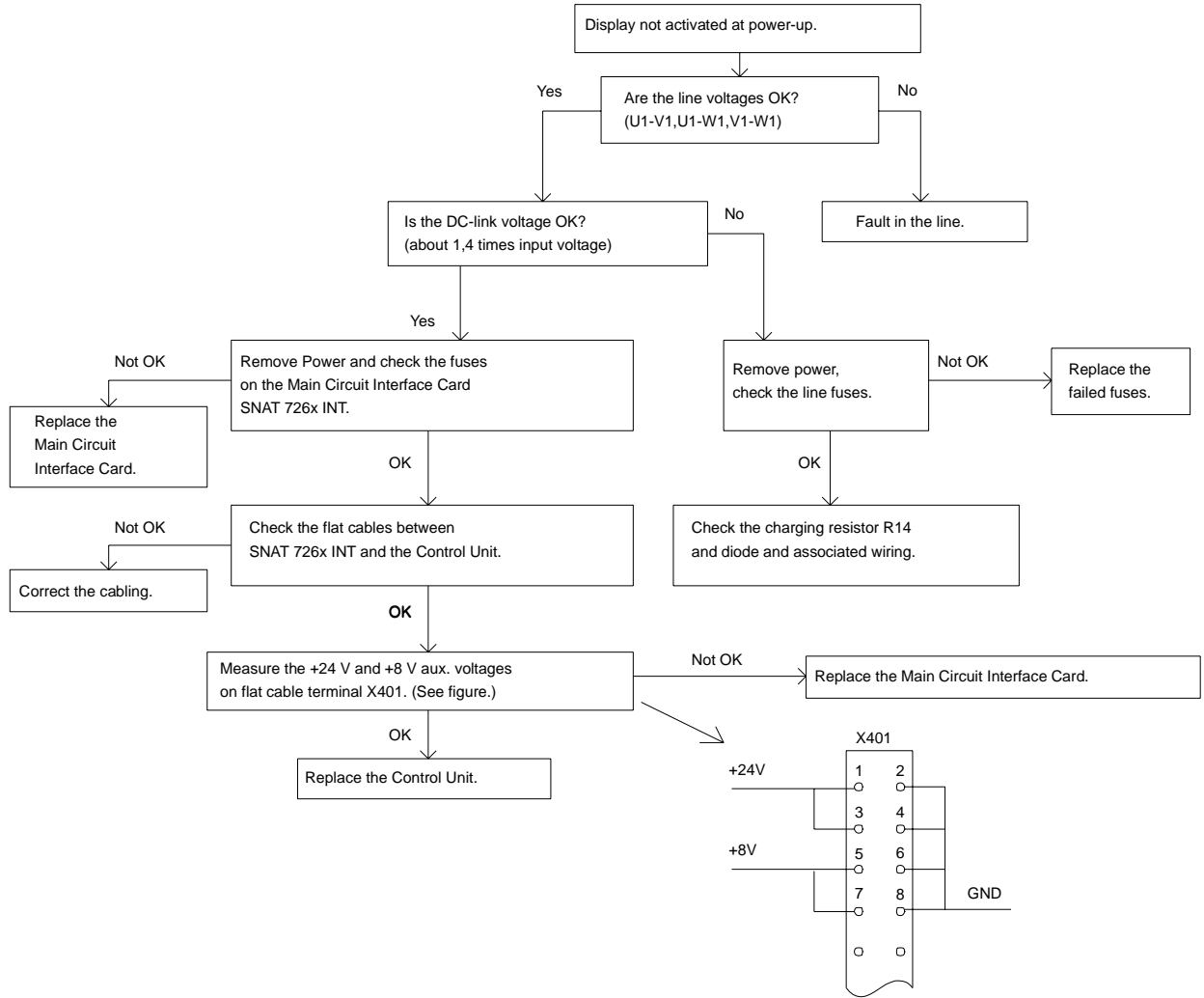

flow.drw

This page intentionally left blank.

Appendix A – ACH 502/504 Technical Data

Input Power

Voltage: 440/460/480/500 VAC \pm 10% for 480 VAC units

380/400/415 VAC \pm 10% for 380 VAC units

Frequency: 48 – 63 Hz

Displacement Power Factor: > 0.98

Line Imbalance: $\pm 3\%$ of V_R

Output Power

Voltage: 0 – V_N , three-phase (full voltage at field weakening point)

Frequency: 0 – 120 Hz

Frequency Resolution: 0.01 Hz

Continuous Current (variable torque): $1.0 \times I_{RSQ}$

Maximum Current (1 min/every 10 min): $1.1 \times I_{RSQ}$

Short Time Overload (2 sec/every 1 min): $1.4 \times I_{RSQ}$

Overcurrent Trip: $3.75 \times I_N$ instantaneous, $2.65 \times I_N$ (RMS)

Field Weakening Point: 30 – 180 Hz

Continuous Loadability of Motor: 100% at rated speed (for F class motor)

Modulation Frequency: 3 kHz

Analog Inputs

Two programmable analog inputs.

Current Reference: 0 – 20 mA, $R_I = 250$ ohms

- Minimum: 0 mA / 4 mA / 0 – 20 mA
- Maximum: 0 – 20 mA

Voltage Reference: 0 - 10 V, $R_I = 200K$ ohms

- Minimum: 0 V / 2 V / 0 – 10 V
- Maximum: 0 – 10 V

Potentiometer: 1K – 10K ohms

Potentiometer Reference Voltage: 10 V, 10 mA

Resolution: AI1 = 10 Bit; AI2 = 12 Bit

Accuracy:

- Analog Control: $\pm 0.5\%$
- Digital Control: $\pm 0.01\%$

Reference Signal Update: < 20 mSec

**Auxiliary Voltage
(for Controls)**

24 VDC $\pm 10\%$, 200 mA

Digital Inputs

Six programmable digital inputs.

< 4.0 V is logical 0

> 18 V is logical 1

Updating of Start/Stop Signal: < 5 mSec

Updating of Other Signals: < 20 mSec

Analog Outputs

Two programmable analog outputs.

0 – 20 mA or 4 - 20 mA, R_L less than or equal to 500 ohms, floating.

Digital Relay Outputs

Three programmable relay outputs, Form C contacts.

Maximum Switching Voltage: 300 VDC / 250 VAC

Maximum Switching Current/Power: 8 A @ 24 VDC, 0.4 A @ 250 VDC,
or 2000 VA @ 250 VAC

Maximum Continuous Current: 2 A rms

Environmental Limits

Ambient Operating Temperature:

- Constant Torque 32° to 113°F (0° to 45°C) NEMA 1
- Variable Torque 32° to 104°F (0° to 40°C) NEMA 1

Storage Temperature: - 40°F to + 158°F (-40°C to +70°C)

Relative Humidity: less than 95%, non-condensing

Continuous Vibration Level: less than 0.5 G

Altitude: 3300 ft (1000 m) above sea level, derate 1% for every 330 ft (100 m) above 3300 ft (1000 m)

Enclosures

NEMA 1, NEMA 12, CHASSIS

Analog Input (AI)	<p>An Analog Input is an input to the ACH 502/504 for a user-supplied DC signal. The signal may be a speed reference or a process feedback. This signal can be from:</p> <ul style="list-style-type: none">• Manual speed pot• DC voltage (0 to 10 VDC)• DC current (0 to 20 mADC) <p>Analog inputs on the ACH 502/504 Keypad Display are abbreviated AI.</p>
Converter	<p>The ACH 502/504 series adjustable frequency drive (AFD) uses a three-phase diode bridge to convert the applied AC line voltage to rectified DC.</p>
DC Bus	<p>The DC Bus is comprised of the:</p> <ul style="list-style-type: none">• DC potential source (internal rectifier bridge or external source),• DC link inductor (connecting the DC bus capacitors to the DC potential source), and• DC bus capacitors that, together with the DC link inductor, provide filtration of the DC source potential and provide some buffering between the DC source and the power inverter section. <p>The DC Bus voltage is $1.35 \times \text{Supply Voltage (V}_{IN})$.</p>
Default	<p>A default is a pre-programmed value for a parameter. When you first install and start your ACH 502/504 drive, all application macro parameter values appearing on the Keypad Display are default settings. You may change these default settings in the process of customizing your drive for your particular drive application.</p>
Digital Input (DI)	<p>The Digital Inputs (DI) receive bistable (two-state On-Off) control signals from the outside world. An example of such would be a two-position Start-Stop selector switch. Digital inputs on the ACH 502/504 Keypad Display are abbreviated DI.</p>
EEPROM	<p>EEPROM is an acronym for Electrically Erasable Programmable Read Only Memory. The EEPROM is the non-volatile memory that stores all parameters, even when power is removed.</p>
ESD	<p>ESD is an acronym for Electrostatic Discharge. ESD cautions indicate situations in which static electricity can damage circuit boards on the ACH 502/504 drive. Follow the precautions listed in the <i>Safety</i> section at the beginning of this manual when installing or removing circuit boards.</p>

Field Weakening Point	This is the point at which the output voltage no longer increases as the output frequency is increased. Operation above this point results in reduced motor torque capability while the output kVA remains constant. Refer to Parameter 20.4.4 (Field Weak Point).
Group	A Group is the second of three display levels in ACH 502/504 programming. Groups group parameters by their functionality, and provide access to them in the same way that Mains provide access to Groups. Groups appear within their respective Mains. For example, if you need to access Group 20.4 or Group 20.3, you must first select Main 20 using specific Keypad procedures. Refer to <i>Chapter 2 – Overview of the ACH 502/504</i> .
IGBT	An IGBT is a fast switching power transistor. ACH 502/504 drives use these in the inverter section as part of the process of changing DC voltage to AC voltage.
I_{RSQ}	This notation abbreviates the rated variable drive output current, in amperes, of an ACH 502/504.
I_N	This notation abbreviates the current which the drive trips and on which settings are based.
Inverter	The inverter changes DC power to AC power for application to the motor windings. Control of the inverter affords variable frequency and voltage to be applied to the motor for control of motor speed and direction.
IR Compensation	IR Compensation is a parameter that provides the motor with extra torque at motor speeds between 0.1 Hz and the set Field Weakening Point. Refer to Parameter 20.4.4 (Field Weak Point) and <i>Field Weakening Point</i> in this glossary.
Joystick Control	Joystick control allows you to use a joystick for external speed and direction drive control through analog input AI1. Refer to Parameter 10.2.2 (External Ref1 Sel).
Line Voltage	Line voltage in this manual means the input voltage that provides power to the ACH 502/504. Line voltage is connected to the ACH 502/504 Terminals L ₁ , L ₂ , and L ₃ . Refer to Start-up Data Parameter D (Supply Voltage). Refer to <i>Supply Voltage</i> in this glossary.
Living Zero	The Living Zero function allows the ACH 502/504 to detect a loss of reference signal. Set Parameter 10.5.1 (Minimum AI1) to a value greater than 0.3 V/0.6 mA for a Living Zero function. You can then supervise the presence of a control signal by setting Parameter 30.1.2 (AI < Min Function) to WARNING or FAULT. A Warning or Fault message will then display if the analog input falls below the set minimum.

Macro A macro is a pre-programmed set of defaults for all of the parameters, which are typical for the specified application. When you select a macro from Start-up Data Parameter B (Applications), you select the macro that most closely defines the drive functions necessary for your particular application. After selecting the macro, you can modify or customize the macro to specifically conform to your application.

Refer to the *ACH 500 Adjustable Frequency AC Drives 3 to 350 HP Programming Manual Including Application Macros* for information on macro applications, functions, and parameter values.

Main A Main is the first of four display levels in the ACH 502/504 programming. Mains provide access to Groups in the same way that Groups provide access to Parameters. For example, to access Main 10 while viewing any of the 28 Operating Data Parameters, press [Right Arrow] on the Control Panel Keypad. From the Main 10 display, press [Up Arrow] to access Main 20, Main 30, and Main 40. Refer to *Chapter 2 – Overview of the ACH 502/504*.

Meggar Test A Meggar Test measures an insulation system's resistance. This test passes a low current, high voltage through a capacitor and measures the resistance of the insulation system. Meggar test results are usually expressed in megohms.

CAUTION: The ACH 502/504 must not be subjected to testing of this type as damage could result. Any wires connected to the ACH 502/504 **MUST** be disconnected from the ACH 502/504 before being subjected to this type of test.

Memory The ACH 502/504 memory provides computer storage for program data and instructions.

Multimeter A multimeter measures electric component functions and values such as voltage (volts), resistance (ohms), and current (amperes). Some multimeters also test diodes.

Operating Data Operating Data defines ACH 502/504 Parameters 1 (Output Frequency) through 28 (Act Value 2 (PFC)) located at the first of four display levels.

Many Operating Data parameters simply display information such as drive temperature and motor speed, and some parameter values can be changed according to drive application needs.

Parameter A Parameter is the last of four display levels in the ACH 502/504 programming. In most cases, Groups provide access to Parameters, and Parameters allow you to modify macros, change start-up settings, and monitor drive and motor functions. Refer to *Chapter 2 – Overview of the ACH 502/504*.

P_R This notation abbreviates the rated constant torque output power rating of an ACH 502/504.

P_{RSQ} This notation abbreviates the rated variable torque output power rating of an ACH 502/504.

Rectifier	A rectifier is a device that permits current flow in one direction and blocks the flow of current in the other direction. In today's technology, rectifiers are of the silicon diode type. The ACH 502/504 uses six rectifiers, configured into a three-phase bridge configuration, as the power converter section of the drive.
Slip Compensation	Slip compensation is a feature in the ACH 502/504 that allows the drive to compensate for motor slip caused by increased load.
Start-up Data	<p>Start-up Data parameters allow you to set certain parameter values prior to starting the ACH 502/504. You set these parameters according to the language you want the drive to display (such as German, Spanish, or English), the supply voltage providing power to the drive, and so on. In most cases, these parameters are one-time settings made only during the drive installation process.</p> <p>Start-up Data parameters are not accessed through the same display levels as Operating Data parameters, Main level, or Group level. Instead, you must first view Operating Data Parameter 1 (Output Frequency), press and hold [*] on the Control Panel Keypad, then press [Right Arrow]. Only this procedure accesses Start-up Data parameters on the ACH 502/504.</p>
Supply Voltage	Supply voltage in this manual means the input voltage that provides power to the ACH 502/504. Supply voltage is connected to ACH 502/504 Terminals L ₁ , L ₂ , and L ₃ . Refer to Start-up Data Parameter D (Supply Voltage). Refer to <i>Line Voltage</i> and V_{IN} in this glossary.
T_R	This notation abbreviates the rated output torque of the motor.
V_{IN}	This notation abbreviates the input voltage to the drive. Refer to <i>Supply Voltage</i> in this glossary.
V_N	This notation abbreviates the voltage for which the drive is programmed.
V_R	This notation abbreviates the rated input voltage, in volts, of an ACH 502/504.

Numerics		D	
115 VAC auxiliary power		DC bus capacitors	iv
ACH 502 connections	3-12	Digital inputs	
115 VAC start		ACH 502 connections	3-11
ACH 502 connections	3-12	ACH 504 connections	4-14
A		Digital outputs	
Ambient temperature for ACH 502	3-2	ACH 502 connections	3-11
Analog inputs		ACH 504 connections	4-15
ACH 502 connections	3-10	Dimensions of ACH 502	3-2
ACH 504 connections	4-14	Dimensions of ACH 504	4-2
Analog outputs		Display contrast, adjusting	2-10
ACH 502 connections	3-11	Display indications	2-7
ACH 504 connections	4-14	Drive code, nameplate identification	2-1
APPLIC. RESTORE	5-3	E	
Application macros		ESD warning	iv
customizing	5-7	External control	5-6
default settings	2-10	F	
overview	2-10	Fault messages	6-1
APPLICATIONS	5-3	Fault tracing	5-5
Audience, intended	1-2	Faults	6-4
Auxiliary 24 VDC		Freeze/fire/smoke	
ACH 502 connections	3-10	ACH 502 connections	3-12
C		G	
Cautions, definition	iii	Ground lug sizes for ACH 502	3-5
Control connections for ACH 502		Group, defined	1-2
external control	3-8	I	
TB1	3-9	Input power	
Control connections for ACH 504		wire sizes for ACH 502	3-4
SNAT-759	4-13, 4-16	wire sizes for ACH 504	4-9
X50	4-13	K	
Control interface card, ESD warning	iv	Keypad control	
Control panel		definition	5-6
display	1-2, 2-7	Keypad functions	2-8
keys	1-2, 2-8	Keys, control panel	1-2
LCD display illustration	2-7		
operation	2-7		
table of keypad functions	2-8		
using the keys	1-2		
Conventions used in this manual	1-2		
Cooling requirements for ACH 502	3-1		

V

Voltage tolerance tests	
hi pot warning	3-6, 4-9
Meggar warning	3-6, 4-9

W

Warning messages	6-1
Warranty information	1-3
Wire sizes for ACH 502	
power	3-4
Wire sizes for ACH 504	
power	4-9
Wiring	
control	5-6

X

X50	
ACH 504 connections	4-14

This page intentionally left blank.



ABB Industrial Systems Inc.
16250 West Glendale Drive
New Berlin, WI 53151
Telephone: (414) 785-3416
Fax: (414) 785-0397

ACH 502-04D
EFFECTIVE 8/31/95
SUPERSEDES 9/1/94

ACS 501 Adjustable Frequency AC Drives 2 to 50 HP

ACS 501-04
EFFECTIVE 4/1/92
NEW