

# ***WELCH-ILMVAC***

## **OWNER'S MANUAL FOR DUOSEAL® VACUUM PUMP MODELS: 1402N, 1402N-01, 1402N-10, 1402N-50, 1402N-53, 1402N-60, 1402N-63, 1402N-90 & 6D735**



### **WARNING**

Never block the Exhaust Port.

If the exhaust port is blocked, pressure will build-up in the pump with the potential of the pump body bursting and causing possible injury to personnel in the area.

Welch-Ilmvac  
5621 W. Howard Street  
Niles, IL 60714  
Phone: (847) 676-8800 (Technical Support)  
Fax: (847) 677-8606  
E-Mail: [gdwelchvacuum@gardnerdenver.com](mailto:gdwelchvacuum@gardnerdenver.com)  
Web-Page: [www.welchvacuum.com](http://www.welchvacuum.com)

Part No. 67-2094 R1.0  
Printed in USA

INSTRUCTION  
WARNING AND CAUTION  
PLEASE READ BEFORE OPERATION

While reading your manual, please pay close attention to areas labeled:  
WARNING AND CAUTION.

The description of each is found below.

WARNING

Warnings are given where failure to observe instruction could result in injury or death to people.

CAUTION

Cautions are found where failure to observe the instruction could result in damage to the equipment, associated equipment and process.

These units conform to the SI International system of units of measurement.

The following symbols (with recommendation of IEC1010 ) of warning will be found on the pump.



Caution - Refer to accompanying documents



Caution - Risk of electrical shock



Caution - Hot surface

WARNING

Motor includes a self resetting thermal cutout and the pump could restart without actuation under fault condition.

## TABLE OF CONTENTS

Section	Page
Section 01 - Installation	
1.10 Introduction	4
Section 02 - Operation	
2.10 Starting Procedures	6
2.20 Operation and System Optimization	7
2.21 High Pressure Operation	7
2.22 Gas Ballast Principles and Usage	7
2.23 System Leaks - Impact and Detection	8
2.30 Shutdown Procedure	8
Section 03 - Maintenance	
3.10 Vacuum Problems	9
3.20 Oil Changes and Oil Level	9
3.30 Shaft Seal Replacement	10
3.40 Repairing Oil Leaks	11
3.50 Repairing Vacuum Leaks	11
3.60 Drive Problems	11
Section 04 - Trouble Shooting Guide	
4.10 Poor Vacuum Readings	12
4.20 Noisy Pump	12
4.30 Excessive Oil Mist	12
Section 05 - Quick Reference Chart	
Chart	13
Section 06 - Dimensional Drawings (with rotation)	
Vacuum Pump	14
Section 07 - Pumping Speed Curves	
Speed Curves	15
Section 08 - Exploded Views and Parts Lists	
Vacuum Pump	16
Section 09 - Accessory Section	
Chart	19
Section 10 - MSDS - Sheets for DIRECTORR® OIL	
MSDS-Sheet for 1407K	21

# Section 1: INSTALLATION

## 1.10 Introduction

This manual has been compiled not only for the care and maintenance of the DUOSEAL pump now in your possession but as a helpful reference and guide for many problems which are usually associated with mechanical vacuum pumps. Take time to read these instructions carefully and preserve this manual for future reference; we think it will be useful to you.

## 1.11 Unpacking

Carefully remove the pump from the shipping case and unfasten and remove the wooden skid. Preserve all paper work and inspection tags for future reference. If damage has occurred from shipment a claim must be filed with the carrier immediately; preserve the shipping container for inspection by the carrier. If you are required to communicate with your dealer or with Welch Vacuum be sure to include your order numbers for quick identification. Do not return the pump to the factory without first completing the on-line request form for returned goods authorization at [www.welchvacuum.com](http://www.welchvacuum.com).

## 1.12 Pump Mounting

### 1.121 Mounted Pumps

Rubber bumpers are supplied with most of our mounted pumps, either loosely or attached. Bumpers are excellent for applications involving a semi-flexible surface such as a bench top; they help to isolate noise and eliminate creeping. For more rigid requirements, the pump base may be bolted directly to a firm foundation with or without the bumpers. All DUOSEAL pumps should be mounted in a horizontal plane.

### 1.122 Unmounted Pumps

If you have purchased an unmounted pump, refer to parts list for information concerning the motor, motor pulley and belt necessary to drive your particular pump at the recommended speed.

## 1.13 Pump Location

The pump should be located preferably in a clean and well ventilated area and adequate space should be provided wherever possible for routine maintenance such as changes of oil and belt adjustments and replacements. Above all, the pump should be located as closely as possible to its system in order to utilize it most efficiently. Its location should include such determining factors as the length and size of connections, the number of bends and the type of exhaust connections.

## 1.14 Exhaust Provisions (See Accessory section in back of this manual.)

Exhaust connections will be determined by the type of system to be exhausted and the desired cleanliness of the atmosphere surrounding the pump. Under normal conditions of mild evacuation nothing more than the dust cap will be necessary to cover the port. Where relatively high gas flows are involved or where the presence of oil vapor is objectionable an exhaust filter may be fastened to the exhaust port in place of the dust cap. The exhaust filters used on our pumps are capable of absorbing and restricting any vapor particle larger than 0.1 micron.



### WARNING

Never block the Exhaust Port. If the exhaust port is blocked, pressure will build-up in the pump with the potential of the pump body bursting and causing possible injury to personnel in the area.

Where extreme exhaust conditions are encountered it is best to pipe the exhaust direct out of the building. Welch recommended wire reinforced PVC, metal pipe or thick walled rubber hose be used as exhaust lines to avoid potential of line becoming crimped or collapsing resulting in the exhaust port being clogged. Be sure to call Welch technical service prior to start-up at 847-676-8800 if you have any questions.

## 1.15 Electrical Power

### 1.151 Power Source Review

Review the power source and the motor rating to be sure they agree in voltage, phase and frequency. On three-phase applications the direction of rotation of the motor must be considered. Make a momentary check rotation at the time of power installation and wiring. Momentary backward rotation of the pump is not harmful. Check the layout drawings for proper direction of rotation.



#### CAUTION

Make certain the power settings on the pump match your power source before attempting to operate the pump

### 1.152 Overload Protection

Motor thermal overload protection is made available by the motor manufacturer as an aid to minimizing motor failure. Overload protection is a standard feature on all single-phase 60Hz motors. Single-phase motors will normally have automatic overload protection. Motors of 1-1/2 horsepower or larger supplied with DUOSEAL pumps contain no overload protection. Installations of such equipment must comply with local electrical codes which dictate appropriate starter and protection devices. It is strongly suggested that you familiarize yourself with the protection supplied with your motor so that you may react accordingly in the event of an emergency. Automatic reset protection is designed to reset itself after a predetermined cooling period. If the fault to the drive remains unaltered, the motor will cycle on and off until the fault is corrected. The motor data plate will indicate the presence of thermal protection.

## 1.16 Vacuum Connections (See Accessory Section in back of this manual.)

### 1.161 Choice of Connections

The choice of connections and fitting can have a very marked effect on the pumping speed at the vacuum chamber. Any connection placed between the pump and the chamber creates an impedance to the flow of gas. This is particularly true at low pressures in the millitorr range where the gas flow is substantially molecular in character. The gas flow is then dependent upon the kinetic activity of the molecules to bring it to the intake of the pump.

### 1.162 The Effects of Conductance

It has been shown that the conductance of a tube is proportional to the cube of its radius and inversely proportional to its length. Therefore it is imperative that the connecting lines be as large in diameter and as short in length as practical. For best results the diameter of the connecting tube should be at least as large as the diameter of the pump intake. To avoid a large reduction in pumping speed at the vacuum chamber, it is clear that the conductance of the line must be considerably greater than the speed of the pump.

### 1.163 Metal Joints

If metal piping or tubing is used, it is preferable to solder or braze all of the connections. Where threaded joints must be used, coat the threads with Loctite® Thread Sealant with PTFE, or Leak Lock and screw together tightly. Flanged connections with elastomer gaskets make excellent demountable joints. Modular vacuum piping and fittings are now extensively used.

### 1.164 Rubber Tubing Joints

Where metal tubing is used between the system and the pump intake, joints can be made by butting the ends of the two sections together in a short section of vacuum hose. Worm-screw band clamps are useful for securing the hose to the tubing. Whatever the joint you choose to use, cleanliness should be of utmost importance.

### 1.165 Valves and Stopcocks

Metal valves or stopcocks may be used in the connecting line between the system and the pump to provide a means of isolating the pump from the system. To minimize the impedance of flow, the valve openings should be as large as possible. Lubricate the rotating plug of the stopcock with a film of vacuum grease sufficiently thick enough to prevent seizure.

1.17 Traps (See Accessory section in the back of this manual.)

1.171 The need for a Trap

Where corrosive vapors or large quantities of condensable vapors are evolved from vacuum processing, a cold trap may be used in the connecting line to the pump. It will help prevent damage to the pump mechanism and reduce oil contamination. The cold trap, immersed in a suitable Dewar flask, is installed so that the vapors may come in contact with the surfaces of the trap and condense. Commonly used refrigerants are liquid nitrogen or dry ice and acetone. The refrigerant to be used depends upon the freezing point of the contaminations. A variety of cold traps are available from Welch-Ilmvac.

1.172 The care of a Trap

When using a cold trap the refrigerant should be maintained at a high level in the flask to keep the trap at a uniformly low temperature. If the trap is re-warmed it may allow re-evaporation of the condensate. The refrigerant add tube on the liquid nitrogen trap should not be obstructed as the refrigerant boil-off can produce dangerously high pressures. If the trap becomes saturated it should be disconnected from the system, drained and cleaned. An increase in pressure in the vacuum system will normally indicate that the trap has become saturated. To clean the trap, remove the trap from the system, allow the trap to warm up and rinse off the condensate with a suitable solvent in a fume hood. Thoroughly clean and dry the trap before reinstalling in the system.

## Section 2: OPERATION

2.10 Starting Procedures

2.101 Starting a DUOSEAL Pump

Before attaching the pump to a system it is well to familiarize yourself with the function and action of the pump which you have now required. Remove the intake and exhaust port plugs and temporarily provide a stopper for the intake and a dust cap for the exhaust. Review the power requirements as described in Section 1.4.



### CAUTION

Do not run this pump with the intake open directly to the atmosphere. The pump will overheat, excessive oil mist will be emitted from the exhaust and the pump will eventually seize.

2.103 Cleanliness

Take every precaution to prevent foreign from entering the pump. A fine mesh screen is provided for this purpose in the intake passage of all DUOSEAL pumps.

2.104 Oil Level Determination

The amount of oil suitable for efficient and satisfactory performance should be determined after the pump has reached its operating temperature. Initially, however, the pump should be filled with fresh oil while the pump is idle. Fill the pump until the oil level falls half way of the oil level window. If after a short period of operation the level should fall, it is likely the result of oil entering some of the interior pockets of the pump. If the oil level rises, this signifies oil has drained into the pump cavity while pump was idle. Shut off pump, then drain oil down to proper level.

If a gurgling sound occurs, additional oil must be added. Mechanical pumps will gurgle in varying degrees under four conditions of performance: [a] when operating at high pressure as in the beginning cycles of evacuation of a chamber; [b] when the oil level in the pump reservoir is lower than required; [c] when a large leak is present in the system; and [d] when the gas ballast is open. Awareness of the possibilities will save time in setting up a system. Best performance of a mechanical pump is generally obtained after sufficient time has been allowed for the pump to come to operating temperature.

## 2.20 Operation and System Optimization

### 2.21 High Pressure Operation

DUOSEAL two-stage pumps are designed to be most efficient when operated at or near their ultimate blanked off pressure. The pump is designed to remove air from a vacuum system at atmospheric pressure to a deep vacuum. When the pump is operated at elevated pressures up to about 10 Torr for long periods of time, the pump will run hotter. At elevated ambient temperatures under these conditions, the thermal protection switch on single phase motors may cut out. Use of an exhaust filter with coalescing element is required.



#### CAUTION

Do not run this pump for prolonged periods of time at or above 10 Torr. The pump will overheat, excessive oil mist will be emitted from the exhaust and the pump will eventually seize.

Leaky vacuum systems, too large a vacuum chamber for pump size or high gas loads to the vacuum systems are causes for extended runs of the pump at elevated pressure. If you need additional information, please contact Welch Vacuum at 847-676-8800, extension 1, for further information and precautions.

### 2.22 Principle of Gas Ballast

#### 2.221 Effects of Unwanted Vapor

Systems which contain undesirable vapors cause difficulty both from the standpoint of attaining desirable ultimate pressures as well as contamination of the lubricating medium. A vapor is defined as the gaseous form of any substance which is usually a liquid or a solid. Water, oil and a mercury vapors are three of the more common vapors encountered in typical vacuum systems. When such vapors exist in a system, the vapors or mixtures of gas and vapor are subject to condensation within the pump; the precipitated liquid may thus ultimately dissolve or become emulsified with the lubricating medium. This emulsion is recirculated to the chambers of the pump where it is again volatilized causing increased pressure within the system.

#### 2.222 Presence and Removal of Condensate

Condensation takes place particularly in the compression stroke of the backing or second stage of a two-stage pump. The compression stroke is that portion of the cycle during which the gas drawn from the intake port is compresses to the pressure necessary to expel it past the exhaust valve. Condensation takes place when the ratio between the initial pressure and the end pressure of the compression is high, that is, when the mixture of vapor and gas drawn from the intake port is compressed from a low pressure to high pressure. By adding air though the gas ballast valve to the mixture of vapor and gas being compressed, the pressure required for delivery past the exhaust valve is reached with a considerably smaller reduction of the volume of the mixture; this, depending upon the amount of air added, condensation of the vapor is wither entirely avoided or substantial reduced.

#### 2.223 Pump Function With Gas Ballast

In a pump functioning on a contaminated system and operating without the gas ballast, compression within the stage takes place in the normal manner until the saturation pressure of the contaminating vapor contained within the mixture of gas and vapor is reached. The saturation pressure of water vapor is that pressure and corresponding temperature at which the dew point of the vapor is reached and condensation occurs. The saturation pressure of water vapor at an ambient temperature of 20°C is 17.5 Torr, while at 60°C, the approximate operating temperature of a pump, the saturation pressure is 149 Torr. The external side of the exhaust valve is subjected to atmospheric pressure. Consequently a compressive force somewhat greater than atmospheric pressure is required to open the valve and permit expulsion of the gas. Sometime during increased compression of the mixture of gas and vapors, the saturation pressure of 149 Torr for the water vapor is reached and the vapor condenses. The condensate is then allowed to emulsify with the oil which is recirculated within the pump stages this providing continued contamination of the system.

#### 2.224 Pump Function With Gas Ballast

On the other hand, when ballast air at atmospheric pressure is supplied to the compression stroke by means of the gas ballast, the partial pressure of the unwanted vapor becomes a very small part of the total pressure of the mixture of gas, vapor and newly supplied air. The vapor is thus prevented from reaching its saturation pressure corresponding to the temperature of the pump and is finally expelled form the pump as a vapor.

#### 2.225 Controlled Ballast Flow

Some degree of variation in ballast flow may be obtained by the amount of opening applied tot he gas ballast. Two or more turns of the gas ballast are sufficient to open it wide. With the gas ballast open, the sound of the exhaust is similar to that of a pump operating against a large leak. Because of the increased pressure introduced into the compression stroke, the pump must work a little hard to function, thus resulting in an increased operating temperature of approximately 8°C over a prolonged period of time. Tests have shown that continuous and prolonged operation for several weeks under these conditions is not injurious to the pump.

## 2.226 Other Forms of contamination control

The application of the gas ballast is a moderate and very successful method for the removal of condensable vapors. For very heavily laden systems, other means of removal such as oil separators may be required. For mild cases of contamination the simple expedient of a cold trap or a change of oil serve the purpose.

## 2.23 System Leaks - Impact & Detection

### 2.231 Large Leaks

The importance of eliminating all leaks in a vacuum system is obvious when it is realized that a leak into the system, at atmospheric pressure, expands in volume by a factor of 750,000 to 10,000,000 or more. The pump must remove this added volume to maintain the desired vacuum. Fortunately a number of effective techniques for leak detection have been developed. Large leaks can be located by pressurizing the system and painting the suspected area with a thick soap solution. Escaping air will produce soap bubbles.

### 2.232 Small Leaks

Small leaks may also be detected by spraying a suspected area with acetone or gases rich in hydrogen, and observing a sudden change in pressure on an electrical gauge. The difference in calibration of these gauges, for air and other gases, will produce a distinct change in the pressure reading. To use this method of detection, the system must be under vacuum and the gauge sensing tube must be located between the pump and the area to be probed. Use extreme caution, as these materials are highly flammable!

### 2.233 Fine Leaks

Locating very fine leaks requires a helium-sensitive, mass-spectrometer leak detector. This instrument will locate leaks which cannot be detected by any other method. Numerous fine leaks can have the total effect of a large leak.

## 2.30 Shutdown Procedures

### 2.301 DUOSEAL Shutdown

A few simple precautions are all that is necessary when shutdown is in order. If a gauge is connected to the system, first isolate the gauge, then turn off the power and open the system to atmosphere. If the pump is removed from the system, cover the intake port with a rubber stopper or suitable cover to protect the pump against contamination and loose particles. If the pump has been contaminated in service and is going to be shelved for a prolonged period it is best to drain the oil and refill with a fresh charge.

## Section 3: MAINTENANCE

### 3.10 Vacuum Problems

#### 3.101 Pressure Determinations

Leakage, contamination and unusual outgassing are the general causes of problems associated with poor vacuum. To operate at maximum efficiency a system must be thoroughly clean. If the system is completely clean and free from leaks, and unwarranted vacuum problems still exist, the pump should be checked. A simple criterion for the condition of a mechanical pump is a determination of its ultimate pressure capability. This can be accomplished by attaching a gauge directly to the pump. The gauge may be any suitable type provided consideration is given to the limitations of the gauge being used. Refer to Paragraph 1-8 for further suggestions. If the pressure is unusually high, the pump may be badly contaminated, low on oil or malfunctioning. On the other hand, if the pressure is only slightly higher than the guaranteed pressure of the pump, an oil change may be all that is required.

#### 3.102 Oil Contamination

The most common cause of a loss in efficiency in a mechanical pump is contamination of oil. It is caused by condensation of vapors and by foreign particles. The undesirable condensate emulsifies with the oil which is recirculated and subject to re-evaporation during the normal cycle of pump activity thus reducing the ultimate vacuum attainable. Some foreign particles and vapors may form a sludge with the oil, impair sealing and lubrication and cause eventual seizure. A gas ballast valve is helpful in removing vapors, especially water, but it is not equally effective on all foreign substances; therefore, periodic oil changes are necessary to maintain efficient operation of the system. The required frequency of changes will vary with the particular system. Experiences with the process will help you determine the normal period of operation before an oil change is required.

#### 3.103 Oil Overheating

This pump is designed to operate continuously below 10 Torr. Continuous operation of this pump above 10 Torr will lead to overheating and eventual pump failure. See Section 2.21, High Pressure Operation.



#### WARNING

Solvents, such as acetone, used to clean different pumps are extremely hazardous. Inhalation may be fatal or harmful. Acetone is also extremely flammable. Never use acetone near heat or open flame. Use only in a well ventilated area.

### 3.20 Oil Changes and Oil Level

#### 3.201 Developing a Maintenance Schedule

After studying many examples of pump failure, Welch has found the most common reason is poor condition of the oil. This is why a regular maintenance schedule for the oil is critical to obtain the longest service life out of your DUOSEAL pump. Welch recommends that you examine the condition of the oil on a daily basis in the early days of a new process or experiment. You want to look for discoloration of the oil and whether the oil level is rising. The discoloration can indicate deterioration of the oil and a rising oil level can indicate condensation of vapors is occurring in the pump. When changes occur, the oil needs to be changed. If no changes in the oil level or color are observed, extended pump service life is obtained if the oil is changed every three to four months.

#### 3.202 Forced Oil Flushing

When you drain oil through the drain valve, you are not removing the oil and contaminants that are inside the pumping mechanism. You are removing oil only from the oil case. Welch recommends a forced oil flush of DUOSEAL pumps be performed at the regular maintenance oil change. The procedure for the forced oil flush is given below.

### 3.203 Forced Oil Flushing Procedure

1. Check the oil level, if the oil level is well above the fill mark (This may indicate either the pump has been overfilled with oil or has ingested a liquid or a large amount of vapor water or organic solvents). Please go to step 2. If the oil level is even with the fill mark and you do NOT suspect corrosive gases or particulates (hence forth called contaminants) ingested have damaged the mechanism, run the pump for 15 minutes to allow the pump oil to warm up before going to step 2.

2. Turn off motor for the vacuum pump. Drain the oil into a clear plastic container (may need pliers to open drain valve). Look for contaminations settling to the bottom of container. If you see contaminants, you will need to repeat step 3 through 5 several times until the oil comes out clear. The oil you drained from the pump came from the oil case only. There may be contaminants in the pumping mechanism. To be sure all contaminants have been removed, the pump mechanism needs to be flushed.

3. Make sure the belt guard is installed before proceeding further. Attach a short hose to the drain valve which runs into a clear plastic container.

4. Flushing the pump is carried out by adding a cup of DUOSEAL vacuum pump oil through the intake port (IN) while the pump is turned on for 15 to 20 seconds. While adding the pump oil, the palm of your hand is placed lightly over the exhaust port (OUT). Look for water coming out of the drain. Turn off the pump.

5. Repeat step 4 until clean oil comes out of the drain hose.

6. Close the drain valve and fill the pump with the amount of DUOSEAL vacuum pump oil your pump needs.

7. Plug the intake (IN) port with a rubber stopper. Turn the pump on and run the pump for 10 minutes. Close the gas ballast.

8. Check the vacuum reading of the pump by connecting a thermocouple gauge tube to the pump's intake. If the pump is running nearly as good as when it was new, the total pressure reading you will read on either of these two gauges will be at least 10 micron.

A simple way to connect the gauge tube to the pump is to run the threaded tip of tube through a hole in a rubber stopper. Use pump oil as a lubricant for inserting the tube. The stopper chosen should be bigger than the outer diameter of the intake flange.

### 3.204 Refilling The Pump

After you are satisfied that the pump has been thoroughly flushed, refill the pump by pouring new DUOSEAL oil into the exhaust port. Fill to the indicated level and start the pump with the intake closed. A gurgling noise is characteristic when high pressure air is drawn through the pump. It should disappear quickly as the pressure within the pump is reduced. If gurgling continues, add sufficient additional oil through the exhaust port until gurgling ceases.

### 3.30 Shaft Seal Replacement

To replace the shaft seal of a pump, drain the oil and remove the pump pulley and key. Remove the screws securing the old seal and pry it loose with a screwdriver or similar wedge, being careful not to mar the surface of the pump body against which the seal fits. Discard the seal and its gasket, inspect all surfaces and repair any damages with a fine abrasive stone. Wipe all sealing areas clean and place a film of DUOSEAL oil on both the shaft and the inside bore of the new shaft seal. Using a new gasket, carefully slide the new seal into position and center it on the shaft. It is not necessary to apply any sealant to the gasket. Tighten the mounting screws uniformly and refill the pump with DUOSEAL oil. Follow instructions included in repair kit.

### 3.40 Repairing Oil Leaks

#### 3.41 Location, Cause and Effect

Oil leaks may develop wherever two mating faces are sealed with a gasket. Such seams may fail as the result of deterioration of the gasket material, loosening of the screws caused by temperature variations, or improper care as the result of previous reassembly. Typical gaskets seams in a mechanical pump are located at the oil level window, the shaft seal, the oil drain, and the mating faces of such mechanical surfaces as the intake chamber cover, the oil case, and the exhaust chamber cover. The importance of a gasket seam is determined principally by its function. If it is a vacuum seal, the ultimate performance of the pump is dependent upon it. If it is an oil seal, the pump may be operated satisfactorily for some time without loss of function. Eventually, of course, a great loss of oil may cause harmful damage.

#### 3.402 Repairing Techniques

An oil seam may be sealed by any of several methods. When an O-ring is employed, the surfaces of the O-ring and its groove should be wiped clean. If the O-ring is not badly deformed or scratched it may be reused by sealing with a slight film of vacuum oil or vacuum grease. Thin composition gaskets are generally used for large irregularly shaped areas. A replacement joint of this type should be thoroughly cleaned of all previous gasket material and the mating surfaces cleaned of any nicks.

### 3.50 Repairing Vacuum Leaks

#### 3.501 Surface Preparation

Good Vacuum seals are an essential and important attribute of a good mechanical pump. A good seal is dependent upon the quality of the mating surfaces as well as the sealant and its preparation. The mating faces should be carefully inspected for any projections or foreign particles which might interfere with proper mating. Slight projections such as nicks and burrs are most easily removed by rubbing with a fine abrasive stone. The surface of the mating parts may be washed with a solvent or alcohol after which they must be thoroughly dried.

#### 3.502 Temporary Repair

Temporary vacuum repairs are often made by covering the known leak with an industrial sealant such as Loctite with PTFE. Such a practice, however, is not recommended for seals of a permanent nature.

### 3.60 Drive Problems

If for any reason the pump will not operate, turn off the power and check the fuse and electrical connections. Then try the power to the motor only by removing the belt. If the motor operates properly try hand-rotating the pump in the proper direction with the pump intake port open. If both turn freely then replace the belt and check the belt tension. The tension should be sufficient to drive the pump without visible slippage. Any greater tension will cause noise and possible damage to the bearings of both the motor and pump. Make certain that both pulley grooves are clean and free from oil. The pulleys must be fastened securely on their respective shafts, and in parallel alignment.

## Section 4: TROUBLE-SHOOTING GUIDE

### 4.10 Poor Vacuum Readings

1. Disconnect vacuum pump from your vacuum system.
2. Obtain 1 gallon of DUOSEAL oil, 1 gallon or larger clear plastic container, clear drain hose (1/4 inch ID by at least 2.5 feet long), rubber gloves, goggles, apron and pliers.
3. Carry out a forced oil flush (See Section 3.3b) if motor can turn pumping mechanism without excessive noise. If pumping mechanism cannot be turned by motor, have pump sent into factory repair center.
4. Check ultimate vacuum with thermocouple gauge. If reading is still unsatisfactory, consult with Welch Technical Service after checking for leaks in your connections.

### 4.20 Noisy Pump

1. Locate noise source on your vacuum pump (motor, belt, pump).
2. If motor makes noise:
  - . Check for loose bolts on motor mount.
  - . Motor may need to be replaced
3. If belt makes noise:
  - . Pulley may be bent. If so, replace.
  - . Loose belt, tighten by loosening bolts on motor and moving motor away from pump until belt exhibits a 1/2 inch deflection.
4. If pump makes noise: vanes may be sticking, carry out a forced oil flush.
5. If noise level is still unsatisfactory, consult with WELCH Technical Service at (847)676-8800.

### 4.30 Excessive Oil Mist

1. Check oil level. Maintain the level between the two lines on the oil window during operation. Too high a level will cause excess oil mist.
2. Determine the vacuum level in your system with a thermocouple gauge or manometer. Be sure the pump is operating at a pressure of 10 Torr or lower for continuous operation.



**CAUTION**  
If not, discuss application with Welch Technical service before proceeding to prevent oil from overheating and breaking down resulting pump failing.

3. A system leak(s) or degassing can cause excessive oil mist. Locate and seal the vacuum leaks. High vapor loads may require a larger pump to compensate.
4. An oil eliminator can be installed for coalescing the oil mist from the exhaust gases. If an oil mist eliminator is already installed, the element may need to be replaced if saturated with oil. Open up oil mist eliminator and examine the element; replace if needed.
5. Check the oil condition for any visible change in color or consistency. Contaminants in the oil can add to the amount of oil exhausted. Carry out a forced oil flush if contamination is discovered. (See Section 3.3b.).

## Section 5: QUICK REFERENCE CHART

Motor Options	1402
Wired for 115V, 60Hz, 1Ph	1402N-01
Wired for 230V, 60Hz, 1Ph	1402N-61
Wired for 230V, 50Hz, 1Ph	1402N-50

Replacement Parts	
Shaft Seal: Lip Seal	1401D -01
Shaft Seal: Mechanical Seal	1401D
Air Filter Screen	41-0660
Intake Chamber Cover Gasket	41-0234
Oil Case Gasket	41-0403
Drain Plug	61-2278
Oil Window	61-2229A
Large Vane	41-0959
Small Vane	41-1487
Large Vane Spring	41-1304
Small Vane Spring	41-1304
Large Vane Spring Holder	41-1685
Small Vane Spring Holder	41-1685
Shaft	41-2093
Upper Exhaust Valve	41-2153
Lower Exhaust Valve	41-2154
Pressure Release Valve	41-0992
Optional Exhaust Filter	1417P-10
Optional Exhaust Filter Element	1417G
Pump Pulley	41-2074
Standard Belt	1405A
Standard Hose Barb Fitting	1393K
Standard Flange Adapter Fitting	1393G

Specifications	
Free Air Displacement, L/M (CFM)	160 (5.6)
Gas Ballast	Yes
Ultimate Pressure, Torr (mbar)	1 (1.3)x10 <sup>-4</sup>
Rotational Pump (RPM)	525
Oil Capacity, quarts (Liters)	2.25 (2.1)
Net Wt. Unmounted Pump, lb (Kg)	82 (37)
Net Wt. Mounted Pump, lb (Kg)	112 (51)
Tubing Needed (I.D. Inches)	13/16
Standard Flange Size	NW25
Intake Thread Size	1-20
Exhaust Thread Size	1-20
Electrical Requirements 1	115V/230V
Electrical Requirements 2	60Hz
Electrical Requirements 3	1 Phase

Repair Kits	
Minor Repair Kit	1402K-05
Major Repair Kit	1402K-06
Base and Belt Guard Kit	1371A-01

# Section 6: DIMENSIONAL DRAWING

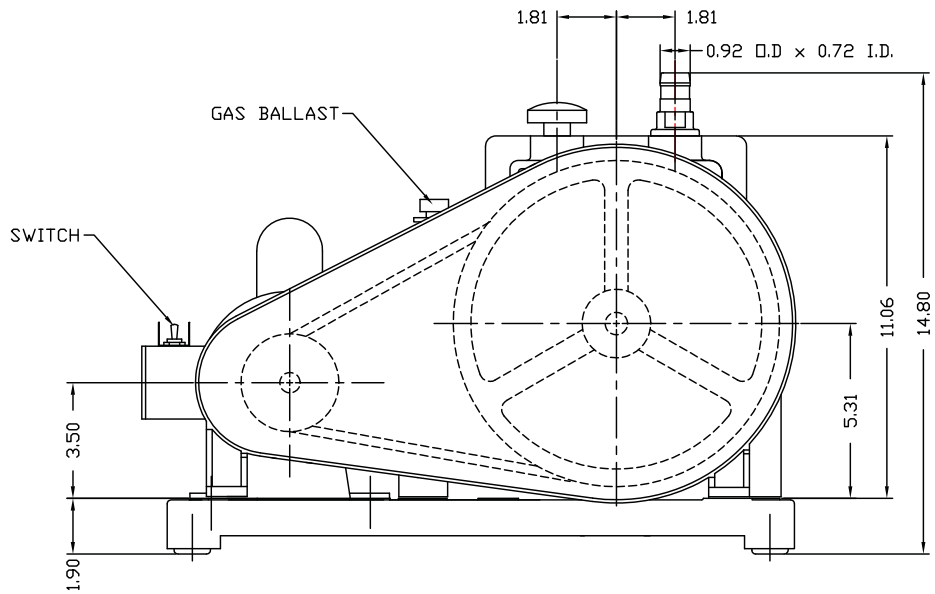
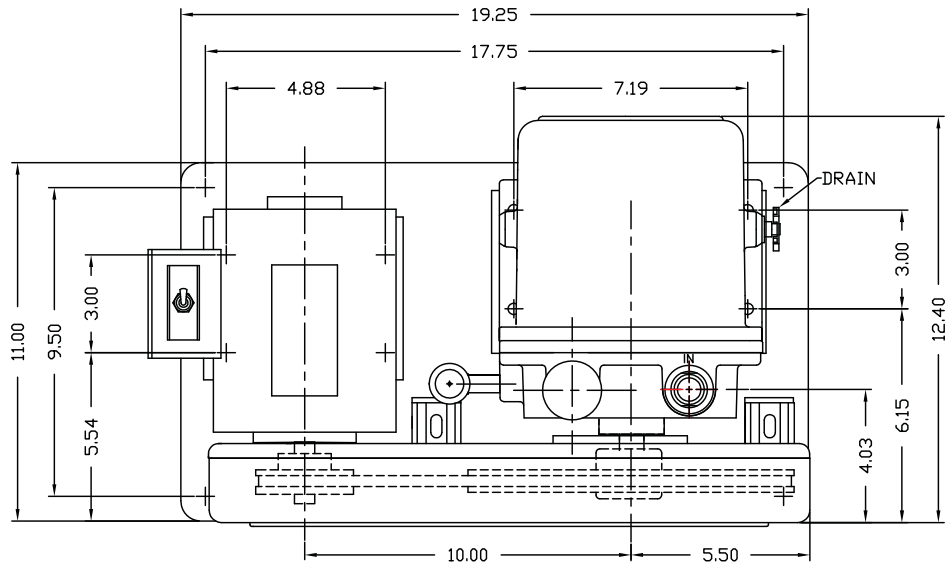

## Section 7: PUMPING SPEED CURVES

### HIGH EFFICIENCY PUMPING CHARACTERISTIC OF DUOSEAL® PUMPS

The low RPM design of DUOSEAL vacuum pumps makes it possible to maintain high pumping efficiencies into the low micron range. High RPM direct drive vacuum pumps, on the other hand, experience a rapid fall off of pumping speed below 100 microns.

A comparison of the DUOSEAL pumping speed curves shown below, versus high RPM pump speed curves conclusively illustrates the superior performance of the DUOSEAL pump.

What does that mean for the vacuum pump user? DUOSEAL pumps provide considerable faster pump down time in the low micron range.

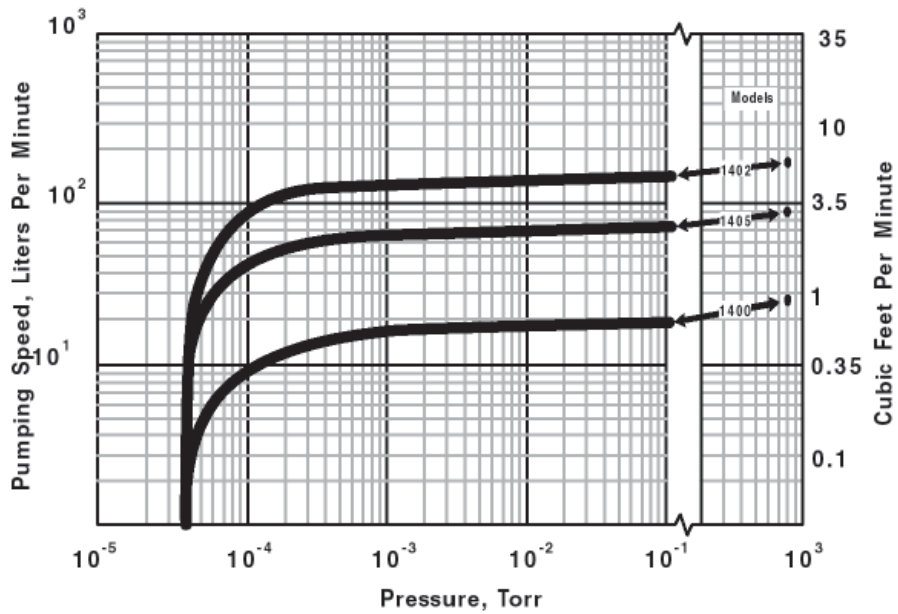

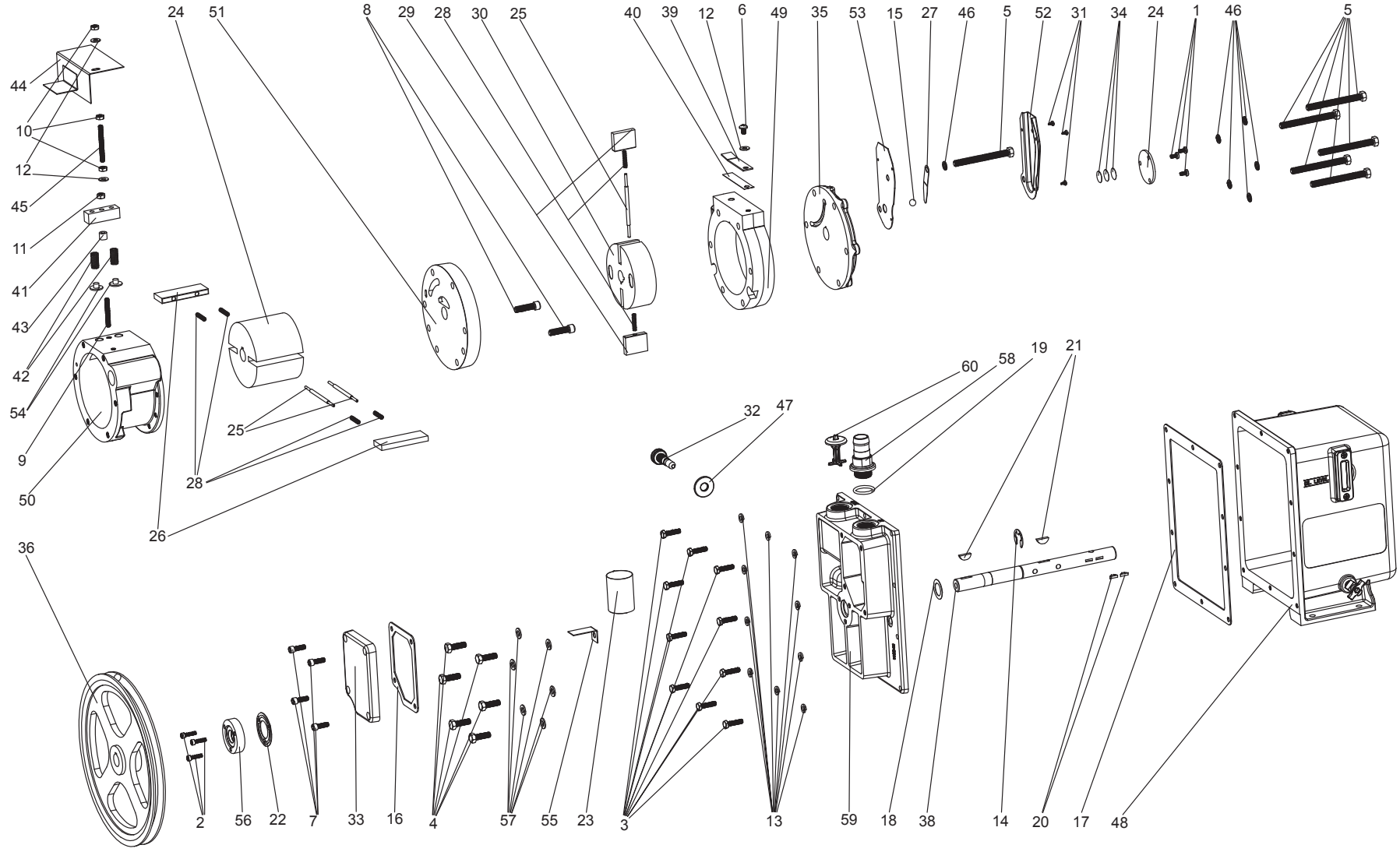

## PARTS LIST

ITEM	QTY	P/N	A*	B*	DESCRIPTION	ITEM	QTY	P/N	A*	B*	DESCRIPTION
1	3	2-00-2706			SCREW PAN HD 10-32 x 3/8" LG.	31	3	62-0259			SCREW #6-1/4 SELF TAPPING
2	3	2-00-6712			SCREW SOCKET HD 10-32 x 3/4" LG.	32	1	41-1736	1	1	GAS BALLAST VALVE
3	10	2-01-0114			SCREW HEX HD 1/4"-20 X 7/8" LG.	33	1	61-8670			COVER, FINISHED
4	6	2-01-0316			SCREW HEX HD 5/16-18 x 1" LG.	34	3	41-1766	1	1	THRUST DISK
5	6	2-01-0356			SCREW HEX HD 5/16-18 x 3-1/4" LG.	35	1	41-2045			SMALL END PLATE, FINISHED
6	2	2-01-5106			SCREW SOCKET HD 1/4-20 x 3/8" LG.	36	1	41-2074			PULLEY w/ SET SCREW
7	4	2-01-6112			SCREW SOCKET HD 1/4-20 x 3/4" LG.	37	1	41-2092			ROTOR, INTAKE
8	2	2-01-6320			SCREW SOCKET HD 5/16-18 x 1-1/4"	38	1	41-2093			SHAFT
9	1	2-01-8123			SETSCREW 1/4-20 X 1-3/4" LG.	39	1	41-2153	1	1	EXHAUST VALVE, UPPER
10	3	2-31-0112			HEX NUT 1/4-20, STEEL	40	1	41-2154	1	1	EXHAUST VALVE, LOWER
11	1	2-36-9900			HEX LOCK NUT 1/4-20	41	1	61-8313A			VALVE BLOCK
12	3	2-61-0000			WASHER, STEEL 3/16	42	2	41-2158	2	2	VALVE SPRING
13	10	2-63-0193			WASHER, LOCK 1/4" MEDIUM	43	1	61-8315A	1	1	VALVE BLOCK SPACER
14	1	4-06-0754	1	1	ROTOR CLIP	44	1	61-8316A			BAFFLE ASSEMBLY
15	1	4-40-1200	1	1	STEEL BALL 3/8" DIA.	45	1	41-2175			SETSCREW 1/4-20 x 2.25" LG
16	1	61-8278B	1	1	GASKET, INTAKE CHAMBER COVER	46	6	41-2363			WASHER 5/16 ID x 1/2 OD
17	1	61-8279B	1	1	GASKET, OIL CASE	47	1	41-2757			LOCK NUT
18	1	41-0508	1	1	WASHER, THRUST	+ 48	1	61-8319B			OIL CASE ASSEMBLY
19	3	61-9284A	1	1	O-RING #214 Fluoroelastomer	49	1	61-8108D			EXHAUST RING
20	2	41-0613	2	2	WOODRUFF KEY #404	50	1	61-8113C			INTAKE RING
21	2	41-0624	2	2	WOODRUFF KEY	51	1	61-8250C			CENTER PLATE
22	1	41-0643			GASKET, SEAL	52	1	61-8309B			PRESSURE RELEASE TUBE #1
23	1	41-0660	1	1	INTAKE SCREEN	53	1	61-8310A			PRESSURE RELEASE TUBE #2
24	1	41-0672			SHAFT END PLATE	54	2	61-8314A			VALVE
25	3	41-1685	3	3	SPRING HOLDER	55	1	61-8329A			BRACKET, INTAKE SCREEN
26	2	41-0959	2		VANE, LARGE	56	1	61-8107A			SHAFT SEAL ASSEMBLY
27	1	41-0992	1	1	PRESSURE RELEASE VALVE	57	6	61-8456A	6	6	WASHER 5/16, COPPER
28	6	61-8559A	4	4	VANE SPRING	58	1	501262			HOSE ADAPTER NW25
29	2	41-1487	2	2	VANE SMALL	59	1	61-8669			LARGE END PLATE
30	1	41-1518			EXHAUST ROTOR	N/S		1401D	1	1	MECHANICAL SEAL OPTION
N/S		1-99-5282	1	1	SEALANT 6cc	N/S		1-99-5282	1	1	SEALANT, 6cc
N/S		1401D	1	1	MECHANICAL SEAL OPTION						

A\*: Major Repair Kit Catalog # 1402K-06

B\*: Minor Repair Kit Catalog # 1402K-05

\*\*1401D is a Mechanical Seal Kit-includes Mechanical Seal, Gasket and 3 screws.

+ Item #48 exploded view shown on page 18

## VIEW AND PARTS LIST FOR MODEL 61-8319B

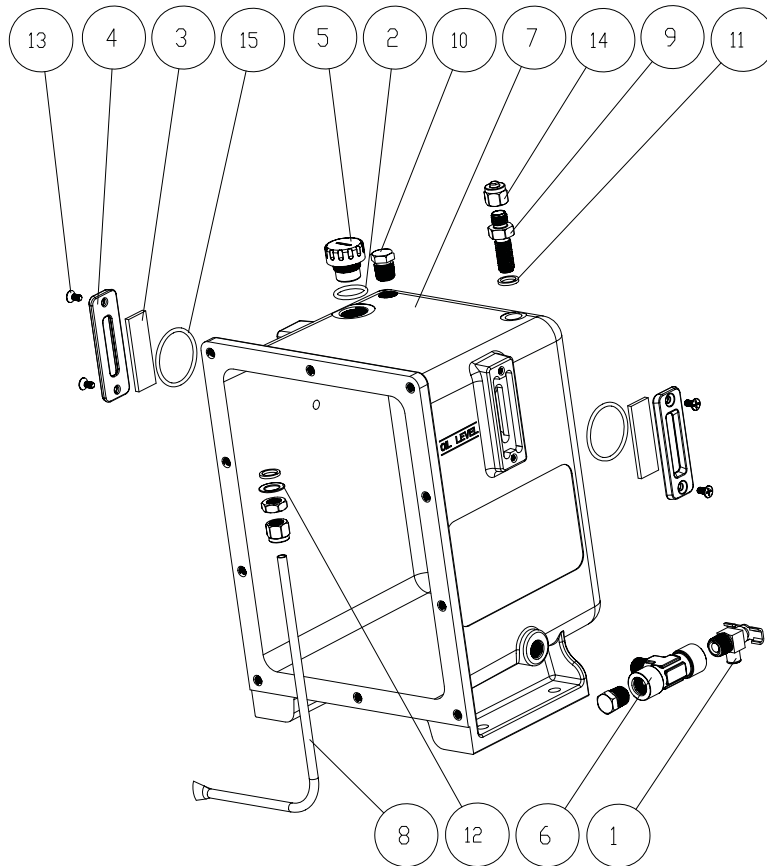

Parts List for Model 61-8319B			
Item	Qty.	P/N	Description
1	1	61-2278	Drain Valve Black/Zinc Plated
2	1	61-2159	O-Ring Fluoroelastomer #116
3	2	61-2229A	Sight Glass Window
4	2	61-2370	Oil Window Cover
5	1	61-2372	Oil Fill Plug
6	1	62-8266	Tee-1/4" NPT Male-Female-Female
7	1	61-8320B	Oil Case
8	1	61-8321B	Plastic Bubbler Tube
9	1	61-8382	Union Bulkhead 1/4" SS
10	2	61-8384	Pipe Plug
11	2	62-0118	O-ring, Tetraseal
12	1	62-0121	Washer
13	4	62-1014	Screw
14	1	62-1141	Nickel Plated Cap
15	2	66-0304	O-Ring Aflas #127

## Section 9: ACCESSORY SECTION

### Exhaust Filter

Filters oil mist from pump exhaust / Easy Replacement  
Reduces pump noise / Filters to 0.3 micron particle size

Standard Exhaust Filter				
Use with pump model	Dimension		Catalog Number	
	Diameter	Height	Filter	Replacement Element
1392, 1399, 1400	2.5	2.5	1417	1417L
1376,1380, 1402,1400	5	6.25	1417P-10	1417G
1397,1374	5	9	1417P-20	1417H-01

### Directional Exhaust Filter

Large, high capacity / Screw-in type / 360 Swivel outlet with tubing connector

Directional Exhaust Filter				
Use with pump model	Dimension		Catalog Number	
	Diameter	Height	Filter	Replacement Element
1392, 1399, 1400	2.5	2.5	1417L	1417L
1376,1380, 1402,1400	5	6.25	1417G	1417G
1397,1374	5	9	1417H-01	1417H-01

### Exhaust Mist Eliminator

Exhaust oil recyclers capture oil mist expelled from the pump, separated air from oil, and return collected oil to the pump via a line connected to the gas ballast inlet. This process effectively reduces oil consumption and minimizes maintenance requirements by extending the time between oil changes.

Catalog Number	Use with pump model
1416H-01	1400
1416C-01	1405, 1376, 1380, 1400

Requires gas ballast connection kit: Cat. No. 141601 - For models 1400,1405,1376,1380,1402

## Coaxial Traps

Reduces oil back streaming / Stainless steel construction / Easy Replacement of Element

ISO Size	Capacity	Diameter	Height	A2	Cat.No.1
NW16	to 4 CFM (140 L/min)	3.75	5.25	8.25	541001
Stainless Steel Element for ISO NW 16 Trap 1					541921
Stainless Steel Element for ISO NW 25 and NW 40 Traps1					541922

Cat. No.1. Element must be ordered with trap.

A2. Distance between ISO NW inlet and outlet connections

## Dry Ice Cold Traps

Removable 3 quarter center well for dry ice/alcohol slurry (do not use acetone) / Visible trapping surface

Cold temperature up to 12 hours depending on vapor / Available with straight tube connections

ISO Size	Diameter	Height	A1	I/O Offset	Cat. No	Replacement Seal Cat. No.
<b>Straight Tube</b>						
1/2 O.D.	10.00	8.25	10.75	3.5	1420H-14	545200

A1. Distance between ISO NW inlet and outlet connections

## Section 10: MSDS-Sheet for DUOSEAL® OIL



### MATERIAL SAFETY DATA SHEET FOR: 1407K DUOSEAL VACUUM PUMP OIL

HMIS Rating: Health: 0 Flammability: 1 Reactivity: 0 Special: X

#### SECTION 1 - IDENTIFICATION

Chemical Name: Highly-Refined Petroleum Lubricant Oils

Synonyms: 1407K DUOSEAL Vacuum Pump Oil

Formula: N/A

Manufacturer's Name: Gardner Denver Thomas, Inc., Welch Vacuum Technology  
4601 Central Avenue  
Monroe, LA 71203

Date Prepared: March 31, 2009

Telephone Number for  
General Information: (847) 676-8800

#### SECTION 2 - HAZARDOUS INGREDIENTS/IDENTITY

##### Exposure Limits in Air

<u>Component</u>	<u>CAS No.</u>	<u>OSHA PEL</u>	<u>ACGIH TVL</u>
Highly-Refined Petroleum Lubricant Oils	64741-88-4	NO	NO

*To the best of our knowledge, the above listed component is not hazardous according to OSHA (1910.1200) or one or more state right-to-know lists.*

#### SECTION 3 - HAZARDS IDENTIFICATION

**Major Route of Entry:** Skin contact

##### **Signs and Symptoms of Acute Exposure**

**Inhalation:** No significant adverse health effects are expected to occur upon short-term exposure to this product. Aspiration of liquid into the lungs can cause severe lung damage or death.

**Eye Contact:** Minimal eye irritation may result from short term contact with liquid, mist, and/or vapor.

**Skin Contact:** This material can cause mild skin irritation from prolonged or repeated skin contact. Injection under the skin, in muscle, or into the blood stream can cause irritation, inflammation, swelling, fever, and systemic effects and mild central nervous system depression. Injection of pressurized hydrocarbons can cause severe, permanent tissue damage. Initial symptoms may be minor. Injection of petroleum hydrocarbons requires immediate medical attention.

THE INFORMATION HEREIN IS GIVEN IN GOOD FAITH, BUT NO WARRANTY, EXPRESS OR IMPLIED, IS MADE.

Revision Date: 03/31/09

Rev. A

P/N: 67-0254 1 of 7



**Ingestion:** If swallowed, large volumes of material can cause generalized depression, headache, drowsiness, nausea, vomiting and diarrhea. Smaller doses can cause a laxative effect. If aspirated into the lungs, liquid can cause lung damage.

**Chronic Health Effects Summary:** Contains a petroleum-based mineral oil. Prolonged or repeated skin contact can cause mild irritation and inflammation characterized by drying, cracking, (dermatitis) or oil acne. Inhalation of petroleum-based mineral oils can cause respiratory irritation or other pulmonary effects after repeated or prolonged inhalation of oil mists at concentrations above applicable workplace exposure levels.

**Conditions Aggravated by Exposure:** Personnel with pre-existing disorders should avoid repeated or prolonged contact with this product.  
**Target Organs:** Skin  
**Carcinogenic Potential:** This product does not contain any components at concentrations above 0.1% which are considered carcinogenic by OSHA, IARC, or NTP.

#### SECTION 4 - FIRST AID MEASURES

**Take proper precautions to ensure your own health and safety before attempting rescue or providing first aid. For more specific information, refer to Exposure Controls and Personal Protection in Section 8 of this MSDS.**

**Inhalation:** Vaporization is not expected at ambient temperatures. This material is not expected to cause inhalation-related disorders under anticipated conditions of use. In case of overexposure, move the person to fresh air.

**Eye Contact:** Check for and remove contact lenses. Flush eyes with cool, clean, low-pressure water while occasionally lifting and lowering eyelids. Seek medical attention if excessive tearing, redness, or pain persists.

**Skin Contact:** Remove contaminated shoes and clothing. Wipe off excess material. Wash exposed skin with soap and water. Seek medical attention if tissue appears damaged or if irritation persists.  
 Thoroughly clean contaminated clothing before reuse. Discard contaminated leather goods. If material is injected under the skin, into muscle, or into the blood stream, seek medical attention immediately.

**Ingestion:** Do not induce vomiting unless directed to by a physician. Do not give anything to drink unless directed to by a physician. Never give anything by mouth to a person who is not fully conscious. If large amounts are swallowed or irritation or discomfort occurs, seek medical attention immediately.

**Notes to Physician:** The viscosity range of the product(s) represented by this MSDS is 100 to 400 SUS at 100°F. Accordingly, upon ingestion there is a low to moderate risk of aspiration. Careful gastric lavage may be considered to evacuate large quantities of material. Subcutaneous or intramuscular injections requires prompt surgical debridement.

THE INFORMATION HEREIN IS GIVEN IN GOOD FAITH, BUT NO WARRANTY, EXPRESS OR IMPLIED, IS MADE.

<b>Revision Date: 03/31/09</b>	<b>Rev. A</b>	<b>P/N: 67-0254</b> 2 of 7
--------------------------------	---------------	----------------------------



## SECTION 5 - FIRE FIGHTING MEASURES

### NFPA Flammability

**Classification:** OSHA/NFPA Class-IIIB combustible liquid. Slightly combustible!  
**Flash Point/Method:** CLOSED CUP: 210°C(410°F). (Pensky-Martens (ASTM D-93)) OPEN CUP: 238°(460°F) (Cleveland.).  
**Lower Flammable Limit:** No data  
**Upper Flammable Limit:** No data  
**Auto-Ignition Temp.:** Not available

### Hazardous Combustion Products:

Carbon Dioxide, carbon monoxide, smoke fumes, unburned hydrocarbons and trace oxides of Sulfur and/or nitrogen.

### Special Properties:

When heated above its flash point temperature, this material will release vapors which, if exposed to an ignition source, can ignite. In enclosed spaces vapors can ignite with explosive force. Mists or sprays may burn at temperatures below the flash point.

### Extinguishing Media:

Use dry chemical, foam, Carbon Dioxide or water fog.

### Fire Fighting Protective

#### Clothing:

Firefighters must use full bunker gear including NIOSH-approved positive pressure self-contained breathing apparatus to protect against potential hazardous combustion or decomposition products and oxygen deficiencies.

## SECTION 6 - ACCIDENTAL RELEASE MEASURES

Take proper precautions to ensure your own health and safety before attempting spill control or clean-up. For more specific information, refer to Emergency Overview on Page 1, Exposure Controls and Personal Protection in Section 8, and Disposal Considerations in Section 13 of this MSDS.

Do not touch damaged containers or spilled material unless wearing appropriate protective equipment. Slipping hazard; do not walk through spilled material. Stop leak if you can do so without risk. For small spills, absorb or cover with dry earth, sand, or other inert non-combustible absorbent material and place into waste containers for later disposal. Contain large spills to maximize product recovery or disposal. Prevent entry into waterways or sewers. In urban area, cleanup spill as soon as possible. In natural environments, seek cleanup advice from specialists to minimize physical habitat damage. This material will float on water. Absorbent pads and similar materials can be used. Comply with all laws and regulations.

## SECTION 7 - HANDLING AND STORAGE

### Handling:

Avoid water contamination and extreme temperatures to minimize product degradation. Empty containers may contain product residues that can ignite with explosive force. Do not pressurize, cut, weld, brase solder, drill, grind or expose containers to flames, sparks, heat or other potential ignition sources. Consult appropriate federal, state and local authorities before reusing, reconditioning, reclaiming, recycling or disposing of empty containers and/or waste residues of this product.

### Storage:

Keep container closed. Do not store with strong oxidizing agents. Do not store at temperatures above 120°F or in direct sunlight for extend periods of time. Consult appropriate federal, state, and local authorities before reusing, reconditioning, reclaiming, recycling or disposing of empty containers or waste residues of this product.

THE INFORMATION HEREIN IS GIVEN IN GOOD FAITH, BUT NO WARRANTY, EXPRESS OR IMPLIED, IS MADE.

Revision Date: 03/31/09

Rev. A

P/N: 67-0254 3 of 7



<b>SECTION 8 - EXPOSURE CONTROLS AND PERSONAL PROTECTION</b>
--

- Engineering Controls:** Provide exhaust ventilation or other engineering controls to keep the airborne concentrations of mists and/or vapors below the recommended exposure limits (see below). An eye wash station and safety shower should be located near the work-station.
- Personal Protective Equipment:** Personal protective equipment should be selected based upon the conditions under which this material is used. A hazard assessment of the work area for PPE requirements should be conducted by a qualified professional pursuant to OSHA regulations. For certain operations, additional PPE may be required.
- Eye Protection:** Safety glasses equipped with side shields should be adequate protection under most Conditions of use. Wear goggles and/or face shield if splashing or spraying is likely, especially if material is heated above 125°F (or 51°C). Have suitable eye wash water available.
- Hand Protection:** Use gloves constructed of chemical resistant materials such as neoprene or heavy nitrile rubber if frequent or prolonged contact is expected. Use heat-protective gloves when handling product at elevated temperatures.
- Body Protection:** Use clean and impervious protective clothing (e.g., neoprene or Tyvek®) if splashing or spraying conditions are present. Protective clothing may include long-sleeve outer garment, apron, or lab coat. If significant contact occurs, remove oil-contaminated clothing as soon as possible and promptly shower. Launder contaminated before reuse or discard. Wear heat protective boots and protective clothing when handling material at elevated temperatures.
- Respiratory Protection:** Vaporization or misting is not expected at ambient temperatures. Therefore, the need for Respiratory protection is not anticipated under normal use conditions and with adequate ventilation. If elevated airborne concentrations above applicable workplace exposure levels are anticipated, a NIOSH-approved organic vapor respirator equipped with a dust/mist prefilter should be used. Protection factors vary depending upon the type of respirator used. Respirators should be used in accordance with OSHA requirements (29 CFR 1910.134).
- General Comments:** Use good personal hygiene practices. Wash hands and other exposed skin areas with plenty of mild soap and water before eating, drinking, smoking, use of toilet facilities, or leaving work. DO NOT use gasoline, kerosene, solvents, or harsh abrasive skin cleaners. Since specific exposure standards/control limits have not been established for this product, the "Oil Mist, Mineral" exposure limits shown below are suggested as minimum control guidelines.
- Occupational Exposure Guidelines Substance:** Oil mist, mineral
- Applicable Workplace Exposure Levels:**
- TWA: 5 (mg/M<sup>3</sup>) from ACGIH (United States)
  - STEL: 10 (mg/M<sup>3</sup>) ACGIH (United States)
  - TWA: 5 (mg/M<sup>3</sup>) from OSHA (United States)

THE INFORMATION HEREIN IS GIVEN IN GOOD FAITH, BUT NO WARRANTY, EXPRESS OR IMPLIED, IS MADE.

<b>Revision Date: 03/31/09</b>	<b>Rev. A</b>	<b>P/N: 67-0254</b> 4 of 7
--------------------------------	---------------	----------------------------



### SECTION 9 – PHYSICAL AND CHEMICAL PROPERTIES

<b>Physical State:</b>	Liquid	<b>Color:</b>	Light Amber to Amber
<b>Odor:</b>	Mild Petroleum Odor	<b>Specific Gravity:</b>	0.88(Water = 1)
<b>pH:</b>	N/A	<b>Vapor Density:</b>	GT 1 (Air = 1)
<b>Boiling Point/Range:</b>	N/A	<b>Melting/Freezing Point:</b>	N/A
<b>Vapor Pressure:</b>	0.01mm of Hg (20°C)	<b>Viscosity (cSt @ 40°C):</b>	65
<b>Density:</b>	7.30 Lbs/gal.	<b>Solubility in Water:</b>	Insoluble in cold water
<b>Viscosity</b>	(ASTM D2161) = 339 SUS @ 100°F	<b>Volatile Characteristics:</b>	Negligible volatility
<b>Additional Properties:</b>	Gravity, API (ASTM D287) = 30.0 @ 60°F		

### SECTION 10 – STABILITY AND REACTIVITY

<b>Chemical Stability:</b>	Stable
<b>Hazardous</b>	
<b>Polymerization:</b>	Not expected to occur.
<b>Conditions to Avoid:</b>	Keep away from extreme heat, sparks, open flame and strong oxidizing conditions.
<b>Materials Incompatibility:</b>	Strong oxidizers
<b>Hazardous</b>	
<b>Decomposition Products:</b>	No additional hazardous decomposition products were identified other than the combustion products identified in section 5 of this MSDS.

### SECTION 11 – TOXICOLOGICAL INFORMATION

For other health-related information, refer to the Emergency Overview on Page 1, and the Hazards identification in Section 3 of this MSDS.

<b>Toxicity Data:</b>	<b>Distillates, petroleum, solvent-refined heavy paraffinic:</b>
ORAL (LD50):	Acute: >5000 mg/kg [Rat].
DERMAL (LD50):	Acute: >2000 mg/kg [Rabbit].

**Distillates, petroleum, solvent-refined heavy paraffinic:**

Mineral oil mists derived from highly refined oils are reported to have low acute and sub-acute toxicities in animals. Effects from single and short-term repeated exposures to high concentrations of mineral oil mists well above applicable workplace exposure levels include lung inflammatory reaction, lipoid granuloma formation and lipoid pneumonia. In acute and sub-acute studies involving exposures to lower concentrations of mineral oil mists at or near current work place exposure levels produced no significant toxicological effects. In long term studies (up to two years) no carcinogenic effects have been reported in any animal species tested. Analyses conducted by method IP346 indicate that the polycyclic aromatic concentration of this mineral oil is below 3.0 weight percent.

### SECTION 12 – ECOLOGICAL INFORMATION

<b>Eco-toxicity:</b>	Analysis for ecological effects has not been conducted on this product. However, if spilled, this product and any contaminated soil or water may be harmful to human, animal, and aquatic life. Also, the coating action associated with petroleum and petroleum products can be harmful or fatal to aquatic life and waterfowl.
<b>Environmental Fate:</b>	An environmental fate analysis has not been conducted on this specific product. However, plants and animals may experience harmful or fatal effects when coated with petroleum-based products. Petroleum-based (mineral) lube oils will normally float on water. In stagnant or slow-flowing waterways, an oil layer can cover a large surface area. As a result, this oil layer might limit or eliminate natural atmospheric oxygen transport into the water. With time, if not removed, oxygen depletion in the waterway might be enough to cause a fish kill or create an anaerobic environment.

THE INFORMATION HEREIN IS GIVEN IN GOOD FAITH, BUT NO WARRANTY, EXPRESS OR IMPLIED, IS MADE.

<b>Revision Date: 03/31/09</b>	<b>Rev. A</b>	<b>P/N: 67-0254</b> 5 of 7
--------------------------------	---------------	----------------------------



**SECTION 13 – DISPOSAL CONSIDERATIONS**

**Hazard characteristic and regulatory waste stream classification can change product use. Accordingly, it is the responsibility of the user to determine the proper storage, transportation, treatment and/or disposal methodologies for spent materials and residues at the time of disposition.**

Conditions of use may cause this material to become a hazardous waste, as defined by Federal or State regulations. It is the responsibility of the user to determine if the material is a hazardous waste at the time of disposal. Transportation, treatment, storage and disposal of waste material must be conducted in accordance with RCRA regulations (see 40 CFR 260 through 40 CFR 271). State and/or local regulations may be more restrictive. Contact the RCRA/Superfund Hotline at (800) 424-9346 or your regional US EPA office for guidance concerning case specific disposal issues.

**SECTION 14 – TRANSPORT INFORMATION**

- DOT Status:** Not regulated by the U.S. Department of Transportation as a hazardous material.
- Proper Shipping Name:** Not regulated
- Hazard Class:** Not regulated
- Packing Group(s):** Not applicable
- UN/NA ID:** Not regulated
- Reportable Quantity:** A Reportable Quantity (RQ) has not been established for any components of this material.
- Placards:** Not applicable.
- Emergency Response Guide No.:** Not applicable.
- HAZMAT STCC No.:** 2911990
- MARPOL III Status:** Not a DOT “Marine Pollutant” per 49 CFR 171.8

**SECTION 15 – REGULATORY INFORMATION**

- TSCA Inventory:** This product and/or its components are listed on the Toxic Substance Control Act (TSCA) Inventory.
- SARA 302/304:** The Superfund Amendments and Reauthorization Act of 1986 (SARA) Title III requires Facilities subject to Subparts 302 and 304 to submit emergency planning and notification information based on Threshold Planning Quantities (TPQs) and Reportable Quantities(RQs) for “Extremely Hazardous Substances” listed in 40 CFR 302.4 and 40 CFR 355. No components were identified.
- SARA 311/312:** The Superfund Amendments and Reauthorization Act of 1989 (SARA) Title III Requires facilities subject to this subpart to submit aggregate information on chemicals by “Hazard Category” as defined in 40 CFR 370.2. This material would be classified under the following hazard categories :No SARA 311/312 Hazard categories identified.
- SARA 313:** This product contains the following components in concentrations above the minimis levels that are listed as toxic chemicals in 40 CFR Part 372 pursuant to the requirements of Section 313 of SARA: No components were identified.
- CERCLA:** The Comprehensive Environmental Response, Compensation, and Liability Act of 1980 (CERCLA) requires notification of the National Response Center concerning release of quantities of “hazardous substances” equal to or greater than the reportable quantities (RQs) listed in 40 CFR 302.4. As defined by CERCLA, the term “hazardous substance” does not include petroleum, including crude oil or any fraction thereof which is not otherwise specifically designated in 40 CFR 302.4. This product or refinery stream is not known to contain chemical substances subject to this statute. However, it is recommended that you contact state and local authorities to determine if there are any other reporting requirements in the event of a spill.

THE INFORMATION HEREIN IS GIVEN IN GOOD FAITH, BUT NO WARRANTY, EXPRESS OR IMPLIED, IS MADE.

<b>Revision Date: 03/31/09</b>	<b>Rev. A</b>	<b>P/N: 67-0254</b> 6 of 7
--------------------------------	---------------	----------------------------



WELCH-ILMVAC  
Vacuum Pump Repair Facility

5621 W. Howard Street  
Niles, IL 60714

Phone: (847) 676-8800 (Technical Support)

Fax: (847) 677-8606

E-Mail: [gdwelchvacuum@gardnerdenver.com](mailto:gdwelchvacuum@gardnerdenver.com)

Web-Page: [www.welchvacuum.com](http://www.welchvacuum.com)

This document contains confidential and trade secret information which is the property of Welch Vacuum Technology and receipt or possession does not convey any rights to loan, sell, or otherwise disclose said information, reproduction or use of said information for any purpose other than that in connection with said information was supplied may not be made without express written permission of Welch. This document is to be returned to Welch upon request and in all events upon completion of the purpose for which it is loaned.

Copyright© 2008 Gardner Denver Thomas, Inc.  
Welch Vacuum Technology

Welch is a registered trademark of Gardner Denver Thomas, Inc.