

WELCH-ILMVAC

CAPTURE[®] PUMP MODELS CRR-1, AND CRR-2 for Total Refrigerant Recovery and Recycling Systems

Contents: Installation
Operation
Maintenance
Parts List
Accessories
Warranty



WARNING
Do not operate CAPTURE pump model
numbers
CRR-1A, -1B, -2A, -2B, at discharge pressures
above 30 PSIG.

Welch-Ilmvac
5621 W. Howard Street
Niles, IL 60714
Phone: (847) 676-8800 (Technical Support)
Fax: (847) 677-8606
E-Mail: gdwelchvacuum@gardnerdenver.com
Web-Page: www.welchvacuum.com

Part No. 67-0382AR2.2
Printed in the U.S.A

Section 1: INSTALLATION

1.1 Introduction

This manual has been compiled not only for the care and maintenance of the CAPTURE™ pump now in your possession, but as a helpful reference guide for many problems which are usually associated with CAPTURE pumps. Take time to read these instructions carefully and preserve this manual for future reference, we think it will be useful to you.

1.2 Unpacking

Carefully remove the CAPTURE pump from the shipping case and unfasten and remove the wooden skid. Preserve all paper work and inspection tags for future reference. If damage has occurred from shipment a claim must be filed with the carrier immediately; preserve the shipping container for inspection by the carrier. If you are required to communicate with your CFC Recovery System Supplier or with Welch Vacuum Technology, Inc. be sure to include your order numbers for quick identification. Do not return the pump to the factory without first calling for a Return Goods Number (RGA) number.

1.3 CAPTURE Pump Mounting

1.3a Mounted CAPTURE Pumps

All CAPTURE pumps should be mounted in a horizontal plane.

1.3b Unmounted Pumps

If you have purchased an unmounted CAPTURE pump, refer to drive requirements table in this manual for information concerning the motor, motor pulley and belt necessary to drive your model CAPTURE pump at the recommend speed.

1.4 Pump Location

The Recovery and/or Recycling System containing the CAPTURE pump should be located preferably in a clean and well ventilated area.

1.5 Discharge Provisions

The discharge connection on CRR-1 is 1 inch female NPT. The discharge connection on CRR-2 is 1-1/2 inch female NPT. An oil separator needs to be attached to the discharge of the CAPTURE pump. The oil return on the oil separator must be connected to the flare fitting located near the suction port. Welch offers an oil separation/return kit for both CAPTURE pumps. For CRR-1, the part number for the oil separation/return kit is 1417K-01. For CRR-2, the part number for the oil separation/return kit is 1417K-05. Figure 1 and Figure 2 illustrate how to connect the oil separator to both CAPTURE pumps.

Both models of CAPTURE pumps should not be run at discharge pressures above 30 PSIG when using a 1HP motor with CRR-1, and 1-1/2 HP motor with CRR-2.



WARNING

The recovery and/or recycling system containing a CAPTURE pump must employ some type of safety device to prevent the CAPTURE pump from running higher than 30 PSIG.

All models of CAPTURE pumps have pump shells rated at 100PSIG. Do **NOT** allow pumps to pressurize above 100 PSIG.

1.6 Electrical Power

1.6a Power Source Review

Review the power source and the motor rating to be sure they agree in voltage, phase and frequency. On three-phase applications the direction of rotation of the motor must be considered. Make a momentary check of rotation at the time of power installation and wiring. Momentary backward rotation of the pump is not harmful. Check the dimensional diagrams in this manual for proper direction of rotation for both CAPTURE pumps.

1.6b Overload Protection

Motor thermal overload protection is made available by the motor manufacturer as an aid to minimizing motor failure. Overload protection is a standard feature on all single-phase 60 Hz motors. Single-phase motors have automatic overload protection.

Welch strongly suggests that you familiarize yourself with the protection supplied with your motor so that you may react accordingly in the event of an emergency. Automatic reset protection is designed to reset itself after a predetermined cooking period. If the fault is corrected. The motor data plate will indicate the presence of thermal protection.

1.7 Suction Port Connections

1.7a Choice of Connections

The choice of piping and valves can have a very marked effect on the pumping speed. Long, small diameter piping or valves connecting the chiller will reduce the CAPTURE pumps rated pumping speed. Lower pumping speeds will increase the time needed to recover the refrigerant vapor to 29 inHg.

Welch strongly recommends that the recovery and/or recycling system should have as few valves as possible between the suction port and the chiller. The valves employed must fully open and be sized for the thread used on the suction port.

It has been show that the conductance of a tube is proportional to the cube of its diameter and inversely proportional to its length. Therefore it is imperative that the connecting lines be as large in diameter and as short in length as practical. For best results the diameter of the connecting tube should be at least as large as the diameter of the suction port. To avoid a large reduction in pumping speed at the chiller, the tubing connecting the chiller to the recovery and/or recycling system be as large in diameter and short as possible.

1.7b Metal Joints

When metal piping or tubing is used, it is preferable to solder or braze all the connections. Where threaded joints must be used, coat the threads with Loctite Pipe Sealant with Teflon and screw together tightly. Flanged connections with elastomer gaskets make excellent demountable joints.

1.8 Vacuum and Pressure Gauges

Two dual vacuum and pressure dial gauge marked off in inches of Hg (or Torr) and PSIG (or Pascal) should be located both on the discharge and suction ports. The gauges can act to visually warn an operator if excessive pressure build-up is occurring and how good a vacuum the chiller is under.

An automatic high pressure limit switch is still required even when two dual vacuum and pressure dial gauges are used.

1.9 Type of Lubricant

All CAPTURE pumps are tested with DUOSEAL® brand oil and shipped with a full charge to prevent unnecessary contamination. The oil acts both as a lubricant and the vacuum seal between the rotating components. An additional supply of oil is furnished with each pump with instructions to drain and discard the oil contaminated in the pump and replace with the fresh oil. DUOSEAL® oil has been especially prepared and is ideally suited for use in CAPTURE pumps because of its desirable viscosity, low vapor pressure and chemical stability. The vacuum guarantee on all CAPTURE pumps applies only when DUOSEAL oil is used.

Section 2: OPERATION

2.1 Starting Procedures

2.1a Starting a CAPTURE Pump

Before installing the CAPTURE pump in a recovery and/or recycling system it is well to familiarize yourself with the function and action of the pump which you have now acquired. Remove the suction and discharge port plugs and temporarily provide a stopper for the suction. The suction port is marked **IN**. The discharge port is marked **OUT**. Review the power requirements as described in Paragraph 1.6.

2.1b Cleanliness

Take every precaution to prevent foreign particles from entering the pump. A fine mesh screen is provided for this purpose in the intake passage of all CAPTURE pumps.

2.1c Oil level Determination

The amount of oil suitable for efficient and satisfactory performance should be determined after the pump has reached its operating temperature. Initially, however, the pump should be filled with fresh oil while the pump is idle. Fill the pump through the oil fill port (see parts exploded view diagram) until the oil level falls half way in the oil level window. If after a short period of operation the level should fall, it is likely the result of oil entering some of the interior pockets of the pump. If the oil level rises, this signifies oil had drained into the pump cavity while pump was idle. Shut off pump, then drain oil down to proper level.

If a gurgling sound occurs, additional oil must be added. CAPTURE pumps will gurgle in varying degrees under four conditions of performance: (a.) when operating at high pressure as in the beginning cycles of evacuation of a chiller; (b.) when the oil level in the pump reservoir is lower than required; and (c.) when a large leak is present in the system. Awareness of the possibilities will save time in setting up a system.

CAUTION: Best performance of a CAPTURE pump is obtained after sufficient time has been allowed for the pump to come to operating temperature. If refrigerant vapor is pumped through the pump before the pump is warmed up, a large quantity of refrigerant will dissolve in the oil. The dissolved refrigerant will superheat and boil off violently as the pump approaches its operating temperature. Excessive oil loss will result. Intake valve should be open gradually to prevent sudden refrigerant rush to the pump.

2.2 Leak Detection

2.2a Large Leaks

The importance of eliminating all leaks in a recovery and recycling system is obvious when it is realized that a leak into the system, at atmospheric pressure, expands in volume by a factor of well over 1000. The CAPTURE pump must remove this added volume to maintain the desired vacuum. Fortunately a number of effective techniques for leak detection have been developed. Large leaks can be located by pressurizing the system and painting the suspected area with a thick soap solution. Escaping air will produce soap bubbles.

2.2b Small Leaks

Small leaks may be detected by spraying area with acetone or gases rich in hydrogen, and observing a sudden change in pressure on a thermocouple gauge. The difference in calibration of these gauges, for air and other gases, will produce a distinct change in the pressure reading. To use this method of detection, the system must be under vacuum and the gauge sensing tube must be located between the pump and the area to be probed. Use extreme caution, as these materials are highly flammable!

2.2c Fine Leaks

Locating very fine leaks requires a helium-sensitive, mass-spectrometer leak detector. This instrument will locate leaks which cannot be detected by any other method. Numerous fine leaks can have the total effect of a large leak.

2.3 Shutdown Procedures

2.3a CAPTURE Pump Shutdown

A few simple precautions are all that is necessary when a shutdown is in order. Turn off the power and open the recovery and/or recycling system to the atmosphere. Be sure the suction port and discharge port of the CAPTURE pump are brought up to atmospheric pressure at the same time. This step will prevent oil from being blown out of the CAPTURE pump.

If the pump is removed from the system, place over the suction and discharge ports a rubber stopper or suitable cover to protect the pump against loose particles falling into the CAPTURE pump. If the pump has been contaminated in service and is going to be shelved for a prolonged period it is best to drain the oil and refill with a fresh charge.

Section 3: MAINTENANCE

3.1 Suction and Discharge Pressure Problems

3.1a Pressure Determinations

Leakage, oil contamination, V-belt and low oil level are four major causes of insufficient suction or discharge pressure. If the recovery and/or recycle system is free from leaks, and unwarranted suction problems still exist. The pump should be checked. A simple criterion for the condition of a CAPTURE pump is a determination of its ultimate pressure capability. This can be accomplished by attaching a dial vacuum gauge directly to the pump. Refer to Paragraph 1.8 for further suggestions. If the suction obtainable is very poor the pump may be badly contaminated, low on oil or malfunctioning. On the other hand, if the pressure is only slightly higher than the guaranteed ultimate pressure of the pump, an oil change may be all that is required.

If the recovery and/or recycle system is free from leaks and sufficient suction exists, but the discharge pressure is insufficient, there are several sources to the problem. A simple explanation is there is an insufficient flow or refrigerant vapor into the CAPTURE pump. Check to see that the tubing connecting the suction port to the chiller are not obstructed. A low oil level or v-belt slippage can cause the same symptoms. If there is a leak in the oil case of the CAPTURE pump, this can also cause insufficient discharge pressure. If none of these explanations fit the observations, the pump may be malfunctioning and should be sent back to a Welch repair facility.

3.1b Oil Contamination

The most common cause of a loss in efficiency in a CAPTURE pump is contamination of oil. It is caused by condensation of vapors and by foreign particles. The undesirable condensate emulsifies with the oil which is recirculated and subjected to re-evaporation during the normal cycle of pump activity thus reducing the ultimate vacuum attainable. Some foreign particles and vapors may form sludges with the oil, impair sealing and lubrication and cause eventual seizure. Periodic oil changes are necessary to maintain efficient operation of the system. The required frequency of changes will vary with the particular system. Experience with the process will help you determine the normal period of operation before an oil change is required.

3.2 Oil Changes and Oil Level

3.2a Draining the CAPTURE pump

An oil change is most easily accomplished with when the capture pump is warm and the oil is less viscous. Use a large container and open the drain valve. A thorough job may be accomplished by tipping the pump slightly if this is possible. The small residue remaining in the pump may be forced out by hand-rotating the pump pulley with the discharge port partially closed and the suction port open. Closing the discharge port completely under these conditions will create excessive pressure at the drain valve which may cause the oil being drained to splatter.

3.2b Flushing the CAPTURE Pump

After removing all the oil, close the drain and pour about four ounces of clean DUOSEAL® oil into the oil fill port (see exposed view drawing for your model CAPTURE PUMP). Open the discharge port and operate the pump for about a minute with the suction port alternately opened and closed to agitate and circulate the fresh oil. Again stop the pump, drain the flushing oil and force out the residue as before.

The amount of flushing oil and the number of flushes will be determined by the extent of contamination and the color of the oil. Under no circumstances should anything other than DUOSEAL oil be used for flushing a CAPTURE pump. The higher vapor pressures of other types of oil will cause difficulty later in the attainment of a vacuum.

3.2c Refilling the CAPTURE Pump

After you are satisfied that the pump has been thoroughly flushed, refill the pump by pouring new DUOSEAL oil into the discharge port. Fill to the recommended level and start the pump with the suction closed. A gurgling noise is characteristic when high pressure air is drawn through the pump. It should disappear quickly as the pressure within the pump is reduced. If gurgling continues, add sufficient additional oil through the oil fill port until gurgling ceases.

3.3 Shaft Seal Replacement

To replace the shaft seal of a pump, drain the oil and remove the pump pulley and key. Remove the screws securing the old seal and pry it loose with a screwdriver or similar wedge, being careful not to mar the surface of the pump body against which the seal fits. Discard the seal and its gasket. Inspect all surfaces and repair any damages with a fine abrasive stone. Wipe all sealing areas clean and place a film of DUOSEAL oil on both the shaft and the inside bore of the new shaft seal. Using a new gasket, carefully slide the new seal into position and center it on the shaft. It is not necessary to apply any sealant to the gasket. Tighten the mounting screws uniformly and refill the pump with DUOSEAL oil. Follow instructions included in repair kit.

3.4 Repairing Oil Leaks

3.4a Location, Cause and Effect

Oil leaks may develop wherever two mating faces are sealed with a gasket. Such seams may fail as the result of deterioration of the gasket material, loosening of the screws caused by temperature variations, or improper care as result of previous reassembly. Typical gasketed seams in a CAPTURE pump are located at the shaft seal and the mating faces of such mechanical surfaces as the suction chamber cover, the oil case, and the discharge chamber cover. The important of a gasketed seam is determined principally by its function. If it is a vacuum seal, the ultimate performance of the pump is dependent upon it. If it is an oil seal, the pump may be operated satisfactorily for some time without loss of function. Eventually, of course, a great loss of oil may cause harmful damage.

3.4b Repairing Technique

Thin composition gaskets are generally used for large irregularly shaped areas. A replacement joint of this type should be thoroughly cleaned of all previous gasket material and the mating surfaces cleaned of any nicks.

3.5 Repairing Vacuum Leaks

3.5a Surface Preparation

Good vacuum seals are an essential and important attribute of a CAPTURE pump. A good seal is dependent upon the quality of the mating surfaces as well as the sealant and its preparation. The mating faces should be carefully inspected for any projections or foreign particles which might interfere with proper mating. Slight projections such as nicks and burrs are most easily removed by rubbing with

a fine abrasive stone. The surface of the mating parts may be washed with a solvent or alcohol after which they must be thoroughly dried.

3.5b Temporary Repair

Temporary vacuum repairs are often made by covering the known leak with an industrial sealant such as Loctite with teflon. Such a practice, however, is not recommended for seals of a permanent nature.

3.6 Drive Problems

If for any reason the pump will not operate, turn off the power and check the fuse and electrical connections. Then try the power to the motor only by removing the belt. If the motor operates properly try hand-rotating the pump in the proper direction with the pump suction port open. If both turn freely then replace the belt and check the belt tension. The tension should be sufficient to drive the pump without visible slippage. Any greater tension will cause noise and possible damage to the bearings of both the motor and pump. Make certain that both pulley grooves are clean and free from oil. The pulleys must be fastened securely on their respective shafts, and in parallel alignment.

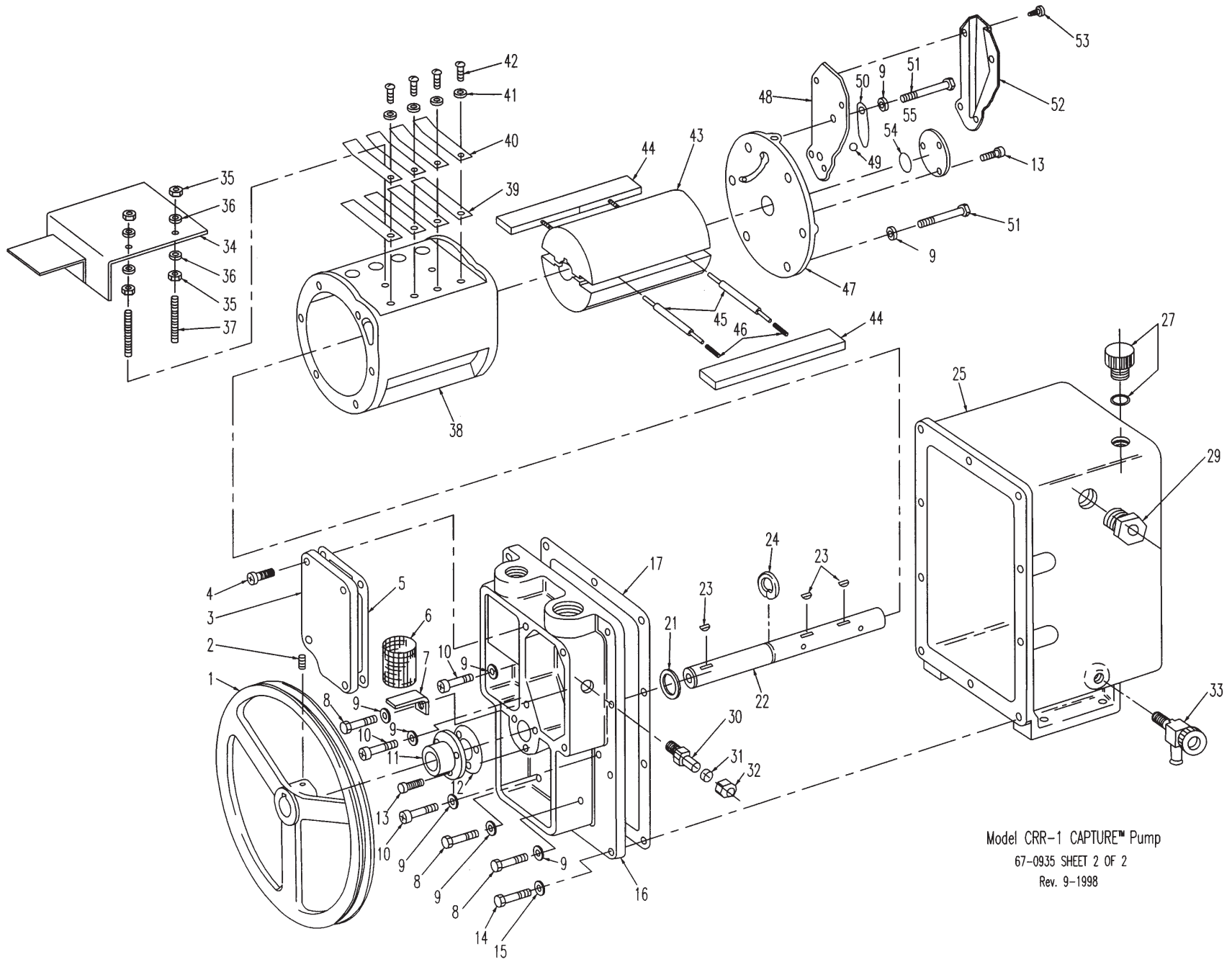

Model CRR-1 CAPTURE™ Pump
67-0935 SHEET 2 OF 2
Rev. 9-1998

PARTS LIST
MODEL 1373A - CRR-1 CAPTURE™ PUMP

<u>ITEM</u>	<u>QTY</u>	<u>PART. NO.</u>	<u>DESCRIPTION</u>
1	1	41-2074	Pulley incl. Item 2
2	1	2-01-9306	Soc Hd Set Screw 5/16-18x3/8
3	1	61-8671	Intake Cover Chamber
4	4	2-01-6112	Soc Hd Screw 1/4-20x3/4
5	1	41-0234	Intake Cover Gasket
6	1	41-1692	Air Filter
7	1	41-0663	Air Filter Bracket
8	3	2-01-0316	Hex Hd Screw 5/16-18x1
9	6	61-8456A	Washer, Copper 5/16
10	13	2-01-6316	Soc Hd Screw 5/16-18x1
11	1	41-2069	Shaft Seal
12	1	41-0643	Seal Gasket
13	6	2-00-2706	Fil Hd Screw 10-32x3/8
14	10	2-01-0114	Hex Hd Screw 1/4-20x7/8
15	10	2-63-0356	Split Lock Washer 5/16
16	1	61-8416D	Large End Plate
17	1	41-0403	Oil Case Gasket
21	1	41-0508	Thrust Washer
22	1	41-1762	Shaft
23	3	41-0624	Woodruff Key
24	1	4-06-0754	Retaining Ring
25	1	61-8417D	Oil Case incl. Items 27, 29 & 33
27	1	41-3035	Oil Filler Plug
29	2	61-8482	Oil Sight
30	1	61-8481	Connector 1/4 NTP x 1/4 Flare
31	1	61-8423	Copper Seal Cap
32	1	61-8422	Short Nut
33	1	41-1734	Drain Valve
34	1	61-8499B	Baffle Plate
35	4	2-31-0112	Hex Nut 1/4-20
36	4	2-61-3100	Steel Washer 1/4
37	2	2-01-8132	Set Screw 1/4-20x2
38	1	41-1760	Ring
39	4	41-1768	Lower Exhaust Valve
40	4	41-1779	Upper Exhaust Valve
41	4	2-61-0000	Steel Washer 3/16
42	4	2-01-5106	Rd Hd Screw 1/4-20x3/8
43	1	41-1761	Rotor
44	2	41-1684	Vane
45	2	41-1685	Vane Spring Holder
46	4	41-1304	Vane Spring
47	1	41-2045	Small End Plate
48	1	41-1005	Pressure Release Tube No.2
49	1	4-40-1200	Steel Ball 3/8
50	1	41-0992	Pressure Release Valve
51	6	2-01-0320	Hex Hd Screw 5/16-18x1-1/4
52	1	41-0986	Pressure Release Tube No.1
53	3	62-0259	Self Tapping Screw #6x1/4
54	1	41-1766	Thrust Disk
55	1	41-0672	End Cap

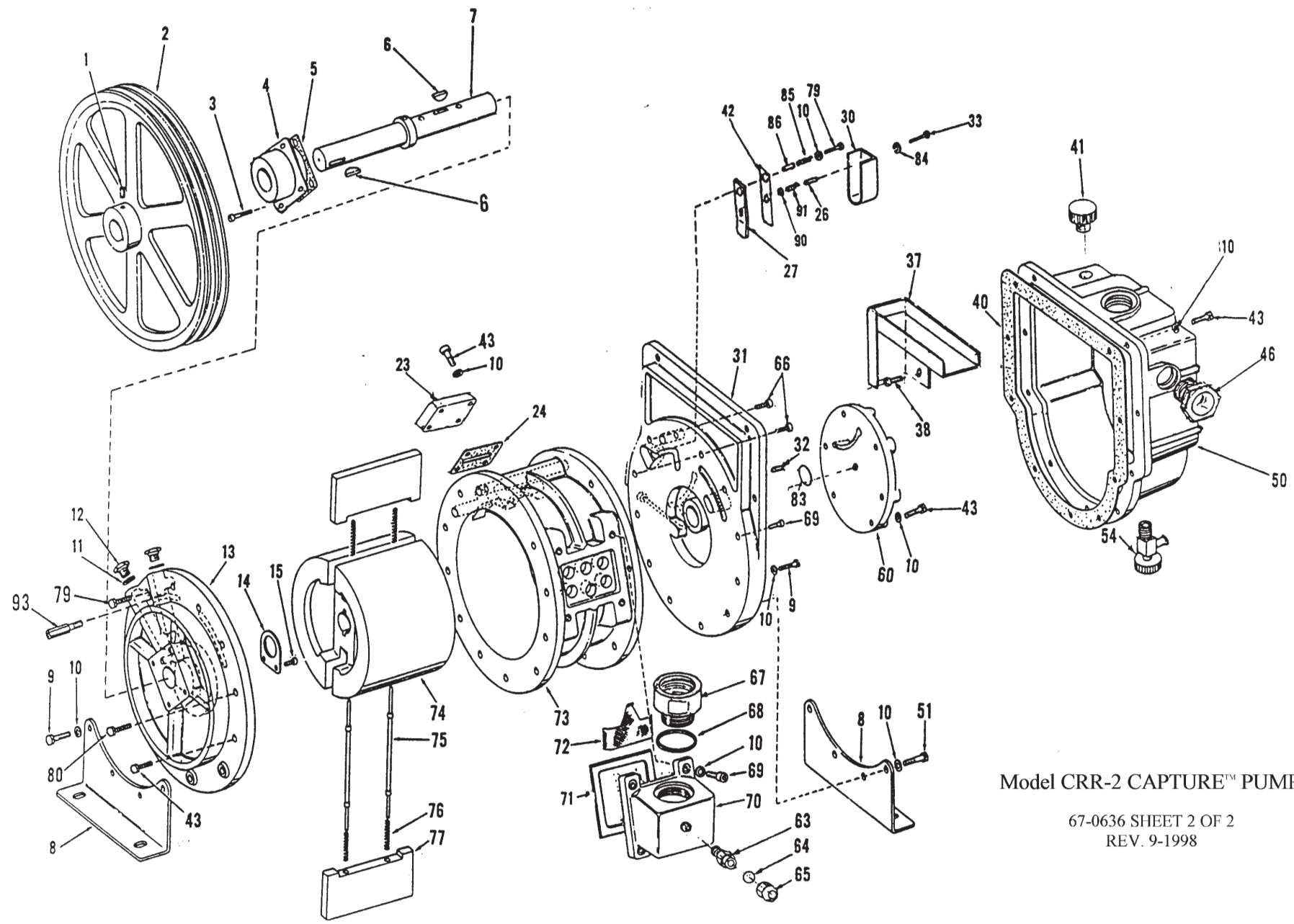

Model CRR-2 CAPTURE™ PUMP

67-0636 SHEET 2 OF 2
REV. 9-1998

PARTS LIST
MODEL 1377A - CRR2 CAPTURE™ PUMP

<u>ITEM</u>	<u>QTY</u>	<u>PART NO.</u>	<u>DESCRIPTION</u>
1	1	2-01-9306	Set Screw 5/16-18x3/8
2	1	41-1492	Pulley incl. Item 1
3	4	2-01-0108	Soc Hd Screw 1/4-20x1
4	1	1401F	Shaft Seal
5	1	41-1494	Seal Gasket
6	2	41-1490	Woodruff Key
7	1	61-8437B	Shaft & Collar
8	2	41-1486	Leg
9	10	2-01-0324	Hex Hd. Screw 5/16-18x1-1/2
10	51	41-2363	Steel Washer
11	3	41-1137	Plug Washer
12	2	41-1136	Plug
13	1	61-8770	Large End Plate
14	1	41-0055	Spacer
15	2	2-00-2704	Fil Hd Screw 10-32x1/4
23	1	61-8483A	Cover
24	1	41-1508	Valve Gasket
26	1	41-2258	Hardened Sleeve 1/4 Size
27	1	61-8538A	Valve Backer
30	1	41-2253	Discharge Valve Cover
31	1	61-8432D	Center Plate
32	1	61-8442A	Orifice.042"
33	2	2-01-0120	Hex Hd Screw 1/4-20x1-1/4
37	1	61-8440A	Baffle Assembly
38	4	2-00-6706	Soc Hd Screw 10-32x3/8
40	1	41-1496	Oil Case Gasket
41	1	41-3035	Oil Fill Plug
42	1	61-8539A	Valve Flapper
43	12	2-01-0316	Hex Hd Screw 5/16-18x1
46	1	61-8441	Oil Sight
50	1	61-8439A	Oil Case Assy. incl Items 37, 38, 41, 46 & 54
51	4	2-01-0328	Hex Hd Screw 5/16-18x1-3/4
54	1	41-1734	Drain Valve
60	1	61-8433C	Small End Plate
63	1	61-8421	Male Connector
64	1	61-8423	Copper Seal Cap
65	1	61-8422	Short Nut
66	13	2-01-6316	Soc Hd Screw 5/16-18x1
67	1	61-8274B	Intake Fitting
68	1	41-0961	Aluminum Washer
69	9	2-01-6314	Soc Hd Screw 5/16-18x7/8
70	1	61-8438A	Intake Chamber
71	1	41-1495	Intake Chamber Gasket
72	1	41-0937	Screen Filter
73	1	41-8691	Ring
74	1	41-1478	Rotor
75	2	41-1489	Spring Holder
76	4	41-1488	Vane Spring
77	2	41-1477	Vane Metal
79	1	2-01-0320	Hex Hd Screw 5/16-18x1-1/4
83	1	41-1469	Spacer Disk
84	1	2-63-0193	Split Lock Washer 1/4
85	1	41-2256	Coil Spring
86	1	41-2257	Sleeve 5/16 Size
90	1	2-69-7007	SS Washer 11/32x11/16x1/16
91	1	41-2259	Coil Spring
93	1	41-2165	Guard Stud

67-0936 sheet 1 of 2
Rev. 7-1998

CRR-1A and CRR-1B Dimensional Diagram

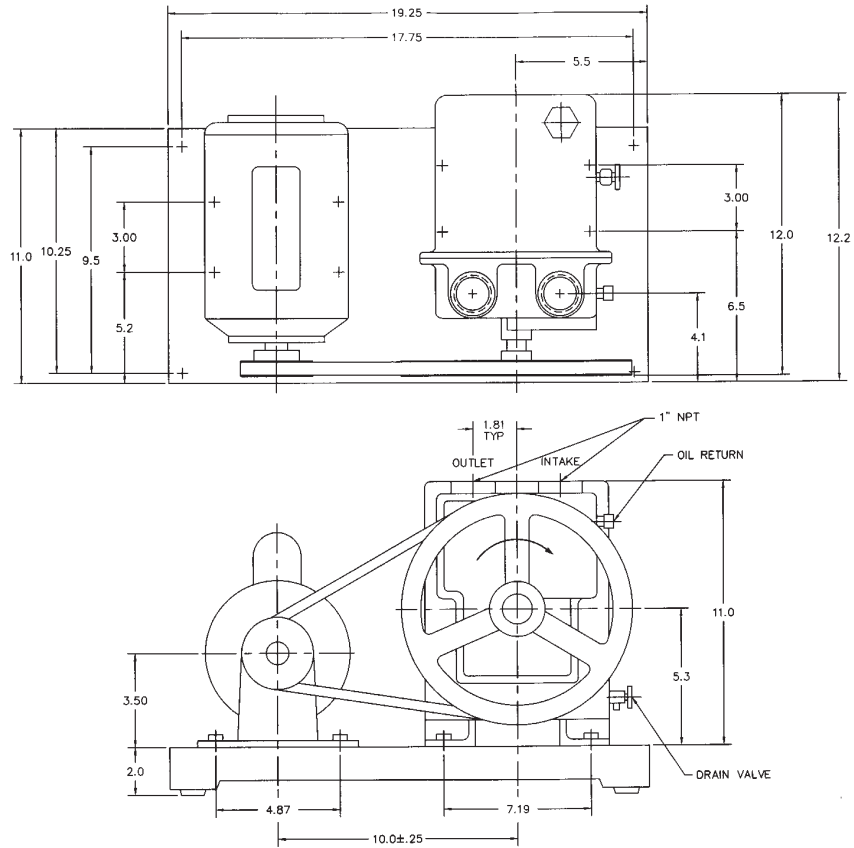

CRR-2A and CRR-2B Dimensional Diagram

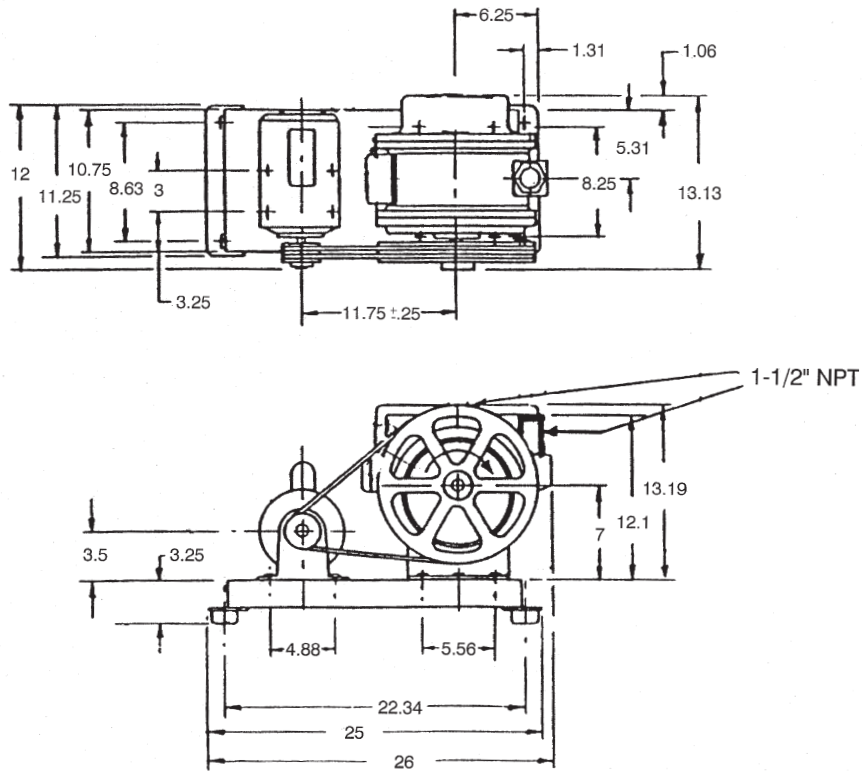

MODEL CRR-1, AND CRR-2 DRIVE REQUIREMENTS

Cat. No.	Belt No.	Motor Pulley Number	Motor No. HP	Volts	Hz	PH	RPM	Remarks
CRR-1A	41-0710	41-0668	41-1940 1 HP	115/230 V	60 HZ	1	1,725	Wired for 115V
CRR-1B	41-0713	41-0667	61-8552A 1 HP	110/220 V	50 Hz	1	1,425	
CRR-2A	41-0715	41-0995	41-1925 1-1/2 HP	115/230 V	60 Hz	1	1,725	
CRR-2B	41-0716	41-0996	41-1992 2 HP	110/220 V	50 Hz	1	1,425	

SPECIFICATIONS

CRR-1A,1B

CRR-2A,2B

Vapor Pumping Rate at
atmospheric pressure, CFM
L/min

10.6
300

17.7
500

Ultimate Pressure, inch of Hg
Torr
Pascal

29.9+
0.030
4

29.9+
0.030
4

Maximum Discharge Pressure, PSIG
Pascal

30
3.1 x 10⁵

30
3.1 x 10⁵

Maximum Discharge Pressure, PSIG
Pascal

30
3.1 x 10⁵

30
3.1 x 10⁵

Pressure Rating of Pump Shell, PSIG
Pascal

100
7.9 x 10⁵

100
7.9 x 10⁵

Suction Connection 0 Female NPT, inch
Discharge Connection - Female NPT, inch
Oil Return Connection 45° Flare
Fitting Size, inch

1
1
¼

1.5
1.5

Minimum Size of System Piping - NPT, inch
Oil Capacity (qts/1)
Pump RPM

1
2.5/2.4
525

1.5
1.5/1.4
400

Dimensions(in/cm)

Length
Width
Height

19.25/48.9
12.31/31.3
11.1/28.1

26/66
13.7/34.8
18.75/47.6

Capture Pump Accessories

<u>Welch Catalog Number</u>	<u>Description</u>
-----------------------------	--------------------

Oil Separation/Return Kit

1417K-01	Kit for CRR-1, 1A, or 1B
1417K-05	Kit for CRR-2, 2A, or 2B

Pump Oil

1407K-11	1 Quart Oil for CAPTURE Pump
1407K-15	1 Gallon Oil for CAPTURE Pump
1407K-20	5 Gallon Container Oil for CAPTURE Pump
1407K-25	55 Gallon Drum, Oil for CAPTURE Pump

Instruction For Assembling Catalog #1417K-01 and 1417K-05 Oil Separator/Return Kits To Welch CAPTURE Pump CRR-1A, CRR-1B, CRR-2A, and CRR-2B.

To install Catalog #1417K-01 or 1417K-05 Oil Separator the following steps should be taken:

1. See Figure 1 for mounting 1417K-01 onto CRR-1A and Fig 2 for mounting 1417K-05 onto CRR-2A.
2. Mount Oil Separator bracket to pump.
3. Install Oil Separator to mounting bracket. Don't tighten bottom nut at this time.
4. Line up Oil Separator inlet port with pump discharge port. Make sure that Oil Separator ports orientation will allow you to make oil return line connection and discharge connection to the system.
5. Using solder fittings and hard copper tubing (cut tubing to required length during assembly) connect Oil Separator inlet port with pump discharge port. Tighten Oil Separator bottom nut to approximately 15 ft lb torque.
6. Before soldering read instructions supplied with Oil Separator:
 - Precharge Oil Separator with pump oil. Use outlet port. Amount of oil required is listed on the Oil Separator label and with instruction included with it.
 - Use a silver solder with a flow point of no higher than 1250 F.
 - Care should be taken not to burn joints.
 - Place a wet rag on the Oil Separator header plate to keep it cool while soldering.
7. Install oil return ¼ soft copper tubing (SAE Connections) between Oil Separator and pump suction chamber.

Figure 1

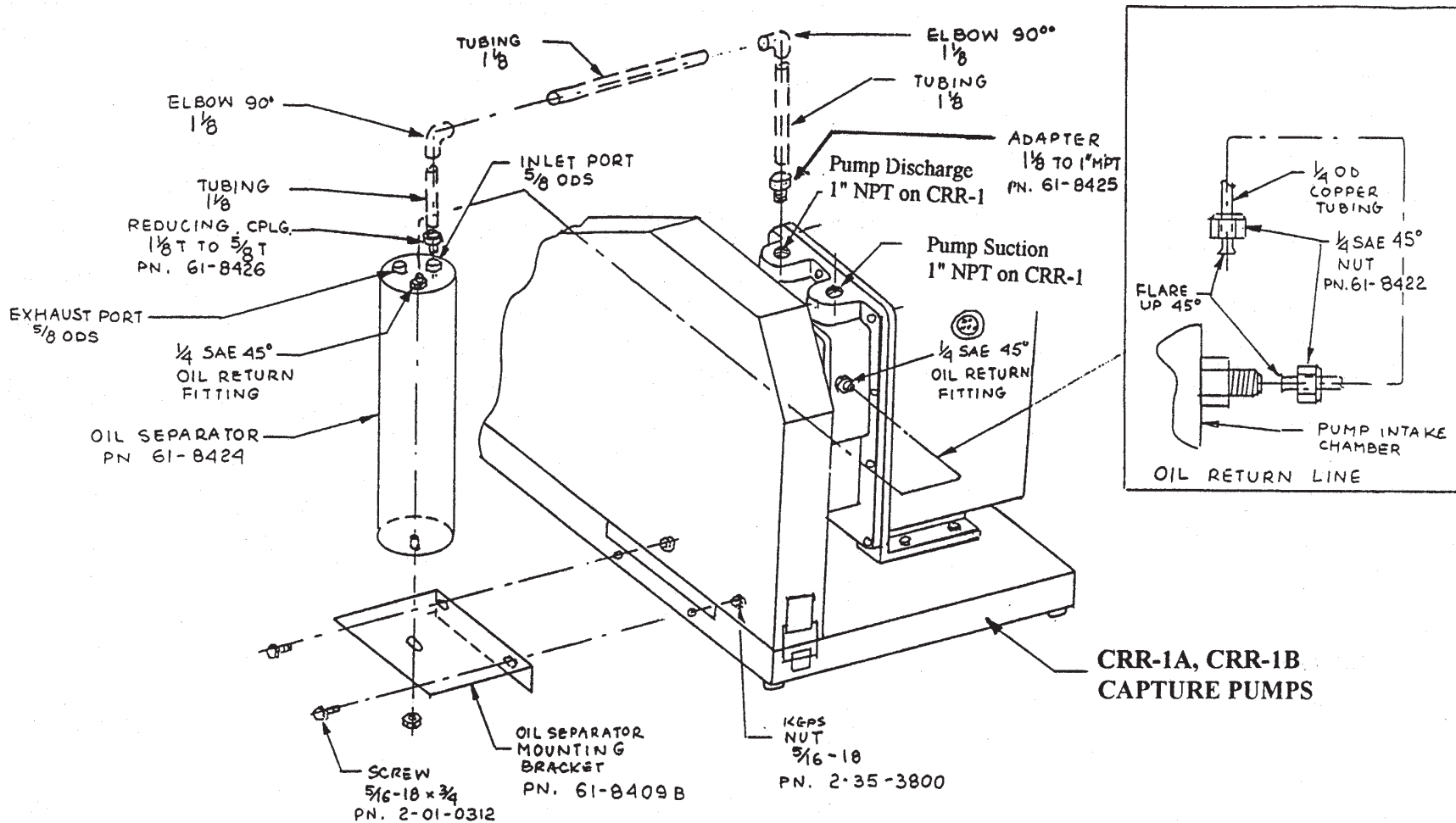

NOTES:

SOLDER ELBOWS AND COPPER TUBING SUPPLIED BY CUSTOMER

Figure 2

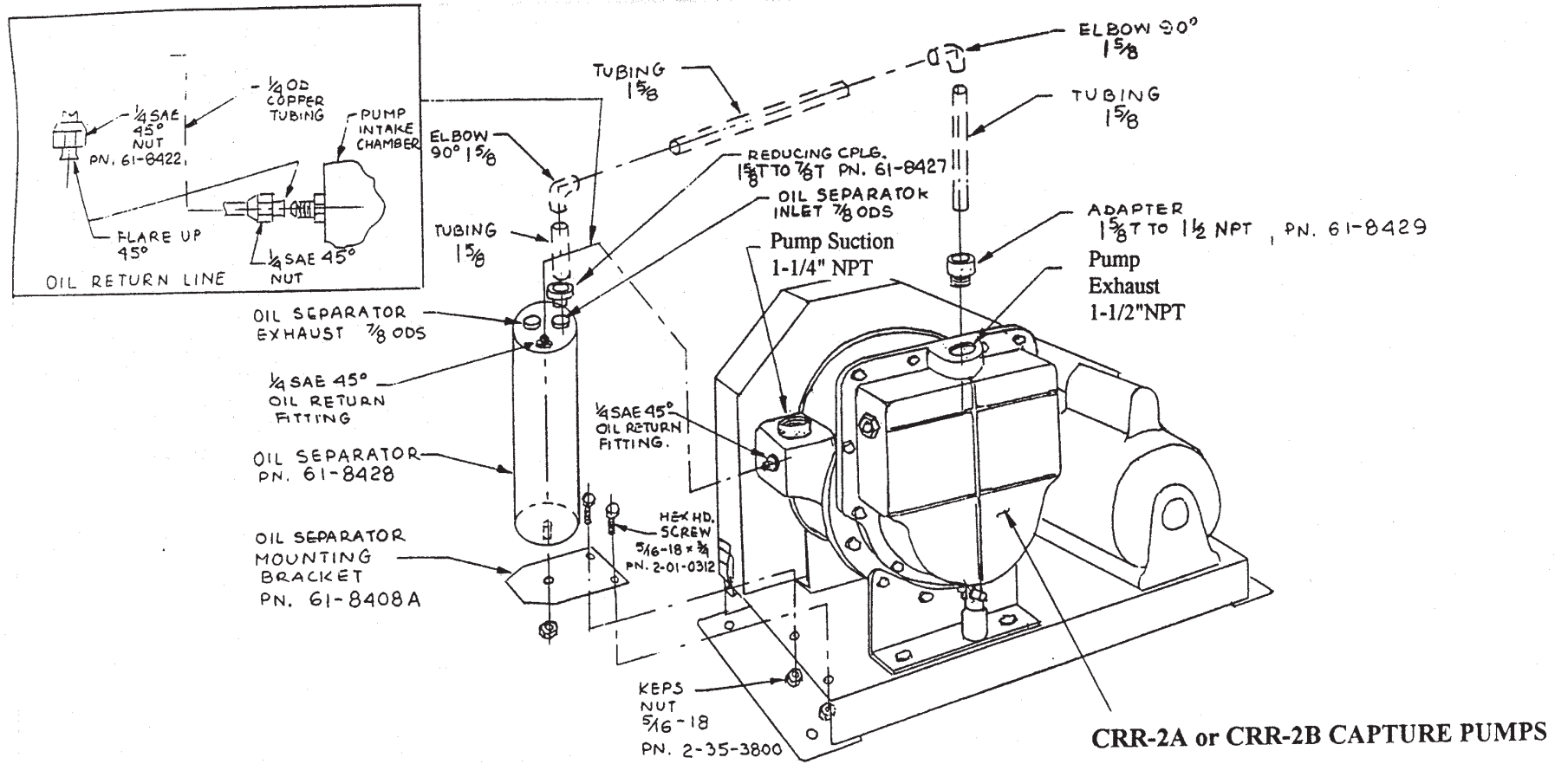

NOTES:

SOLDER ELBOWS AND COPPER TUBING SUPPLIED BY CUSTOMER.

WARRANTY

This Welch-IImvac product is warranted to be free from defects in material and workmanship. The liability of Welch-IImvac under this warranty is limited to servicing, adjusting, repairing or replacing any unit or component part which in the judgment of Welch-IImvac has not been misused, abused or altered in any way or damaged by ingestion of foreign material causing impaired performance or rendering it inoperative. Foreign materials includes solids, liquids, corrosive gases and recondensed water or solvent vapor. No other warranty: servicing, adjusting, repairing or replacing shall be at the discretion of Welch-IImvac. Vacuum pumps that have been operated within vacuum system, or other system, for any period, however short, will be repaired under this warranty rather than be replaced.

The warranty is effective for one year from the date of original purchase when:

1. The warranty card has been completed and returned.
2. The product is returned to the factory or other designated service centers, prepaid.
3. The product in our judgment is defective through no action or fault of the user.

If the product has become defective through misuse, abuse, alteration or ingestion of foreign material, repairs will be billed regardless of the age of the product. In this event, an estimate of the repair costs will be submitted and authorization of these charges will be required before the product is repaired and returned.

WELCH-ILMVAC
Vacuum Pump Repair Facility

5621 W. Howard Street

Niles, IL 60714

Phone: (847) 676-8800 (Technical Support)

Fax: (847) 677-8606

E-Mail: gdwelchvacuum@gardnerdenver.com

Web-Page: www.welchvacuum.com

OWNER'S MANUAL
For
CAPTURE® PUMPS
MODELS CRR-1, & CRR-2
Part No. 67-0382A

CAPTURE, WELCH and DUOSEAL are registered trademarks of Welch-Ilmvac