

Measurement data	
Filename	E315 CHILLER #10 (GACM127699)
Measurement date	3/22/18 15:11
Report generated from file	10.3 UCPL_hor_2018-03-22 15-11-00.5. Kevin Frazee.XML
Report generated date	3/26/18 23:48
Operator	Kevin Frazee
Measurement Program	EASY-LASER® Shaft Horizontal AX3
Measurement Unit	mils
Serial no. Display / detector(s)	43278 / 43331 / 43305 / 0
Compressor Temperature	130 F
Compressor Pressure	70 PSIG

Distances	(Inch)
Coupling diameter	8.0
SC	8.0
SM	9.5
M - MF1	14.3
MF1 - MF2	36.0

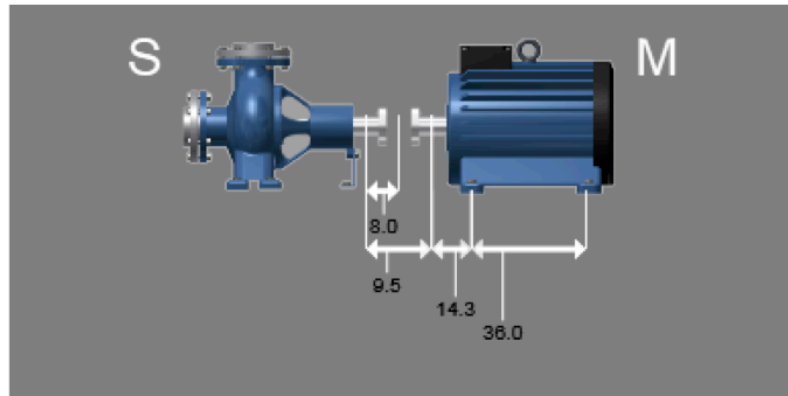

Machine data	Stationary Machine S	Movable Machine M
Name	Compressor	Motor
Movable pair of feet	0	4
Locked pair of feet	4	0
Softfoot measured	No	No

Thermal compensation	Stationary Machine S	Movable Machine M
Vertical offset		+ 1.250 mils (above Comp)
Horizontal offset		0
Vertical angle		0
Horizontal angle		0

Tolerance			
Offset	+ / - 6.000 mils	Angle	+ / - 0.500 mils/Inch

### Result Vertical

Result		Within tolerance
Offset	-6.850 mils	NO
Angle	0.400 mils/Inch	YES

Feet values	(mils)
MF1	-0.530
MF2	13.870

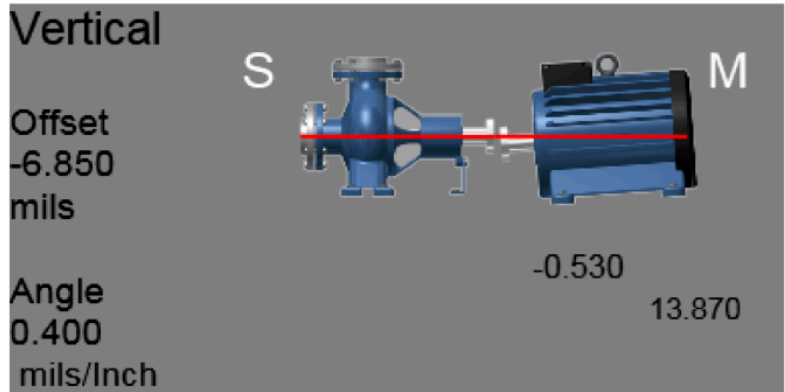

### Result Horizontal

Result		Within tolerance
Offset	-3.100 mils	YES
Angle	0.050 mils/Inch	YES

Feet values	(mils)
MF1	-19.550
MF2	-37.550

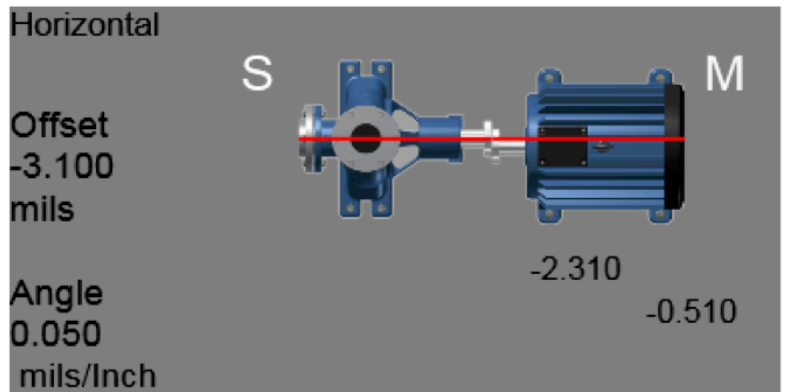

**Notes:**

All readings are pre-adjustment.

Date: 3/26/2018

Sign: \_\_\_\_\_