

5.0 V, 16 Kbit (2 Kb x 8) TIMEKEEPER[®] SRAM**Features**

- Integrated, ultra low power SRAM, real-time clock, and power-fail control circuit
- BYTEWIDE[™] RAM-like clock access
- BCD coded year, month, day, date, hours, minutes, and seconds
- Typical clock accuracy of ± 1 minute a month, at 25 °C
- Software controlled clock calibration for high accuracy applications
- Automatic power-fail chip deselect and WRITE protection
- WRITE protect voltages (V_{PFD} = power-fail deselect voltage):
 - M48T02: $V_{\text{CC}} = 4.75$ to 5.5 V;
 $4.5 \text{ V} \leq V_{\text{PFD}} \leq 4.75 \text{ V}$
 - M48T12: $V_{\text{CC}} = 4.5$ to 5.5 V;
 $4.2 \text{ V} \leq V_{\text{PFD}} \leq 4.5 \text{ V}$
- Self-contained battery and crystal in the CAPHAT[™] DIP package
- Pin and function compatible with JEDEC standard 2 K x 8 SRAMs
- RoHS compliant
 - Lead-free second level interconnect

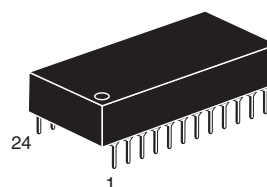

PCDIP24
battery/crystal
CAPHAT[™]

Contents

- 1 Description 5**
- 2 Operation modes 7**
 - 2.1 READ mode 7
 - 2.2 WRITE mode 9
 - 2.3 Data retention mode 10
- 3 Clock operations 12**
 - 3.1 Reading the clock 12
 - 3.2 Setting the clock 12
 - 3.3 Stopping and starting the oscillator 13
 - 3.4 Calibrating the clock 13
 - 3.5 V_{CC} noise and negative going transients 16
- 4 Maximum ratings 17**
- 5 DC and AC parameters 18**
- 6 Package mechanical data 21**
- 7 Part numbering 22**
- 8 Environmental information 23**
- 9 Revision history 24**

List of tables

Table 1.	Signal names	5
Table 2.	Operating modes	7
Table 3.	READ mode AC characteristics	8
Table 4.	WRITE mode AC characteristics	10
Table 5.	Register map	13
Table 6.	Absolute maximum ratings	17
Table 7.	Operating and AC measurement conditions	18
Table 8.	Capacitance	18
Table 9.	DC characteristics	19
Table 10.	Power down/up AC characteristics	20
Table 11.	Power down/up trip points DC characteristics	20
Table 12.	PCDIP24 – 24-pin plastic DIP, battery CAPHAT™, package mech. data	21
Table 13.	Ordering information scheme	22
Table 14.	Document revision history	24

List of figures

Figure 1.	Logic diagram	5
Figure 2.	DIP connections	6
Figure 3.	Block diagram	6
Figure 4.	READ mode AC waveforms	8
Figure 5.	WRITE enable controlled, WRITE AC waveform	9
Figure 6.	Chip enable controlled, WRITE AC waveforms	9
Figure 7.	Checking the BOK flag status	11
Figure 8.	Crystal accuracy across temperature	15
Figure 9.	Clock calibration	15
Figure 10.	Supply voltage protection	16
Figure 11.	AC testing load circuit	18
Figure 12.	Power down/up mode AC waveforms	19
Figure 13.	PCDIP24 – 24-pin plastic DIP, battery CAPHAT™, package outline	21
Figure 14.	Recycling symbols	23

1 Description

The M48T02/12 TIMEKEEPER[®] RAM is a 2 Kb x 8 non-volatile static RAM and real-time clock which is pin and functional compatible with the DS1642.

A special 24-pin, 600 mil DIP CAPHAT[™] package houses the M48T02/12 silicon with a quartz crystal and a long life lithium button cell to form a highly integrated battery-backed memory and real-time clock solution.

The M48T02/12 button cell has sufficient capacity and storage life to maintain data and clock functionality for an accumulated time period of at least 10 years in the absence of power over the operating temperature range.

The M48T02/12 is a non-volatile pin and function equivalent to any JEDEC standard 2 Kb x 8 SRAM. It also easily fits into many ROM, EPROM, and EEPROM sockets, providing the non-volatility of PROMs without any requirement for special WRITE timing or limitations on the number of WRITES that can be performed.

Figure 1. Logic diagram

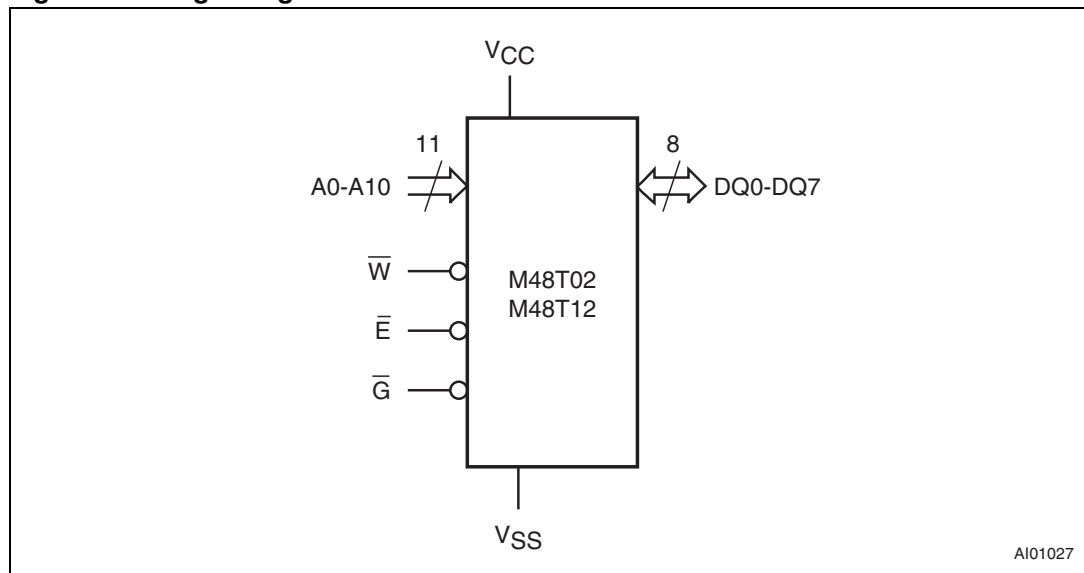

AI01027

Table 1. Signal names

A0-A10	Address inputs
DQ0-DQ7	Data inputs / outputs
\bar{E}	Chip enable
\bar{G}	Output enable
\bar{W}	WRITE enable
V _{CC}	Supply voltage
V _{SS}	Ground

Figure 2. DIP connections

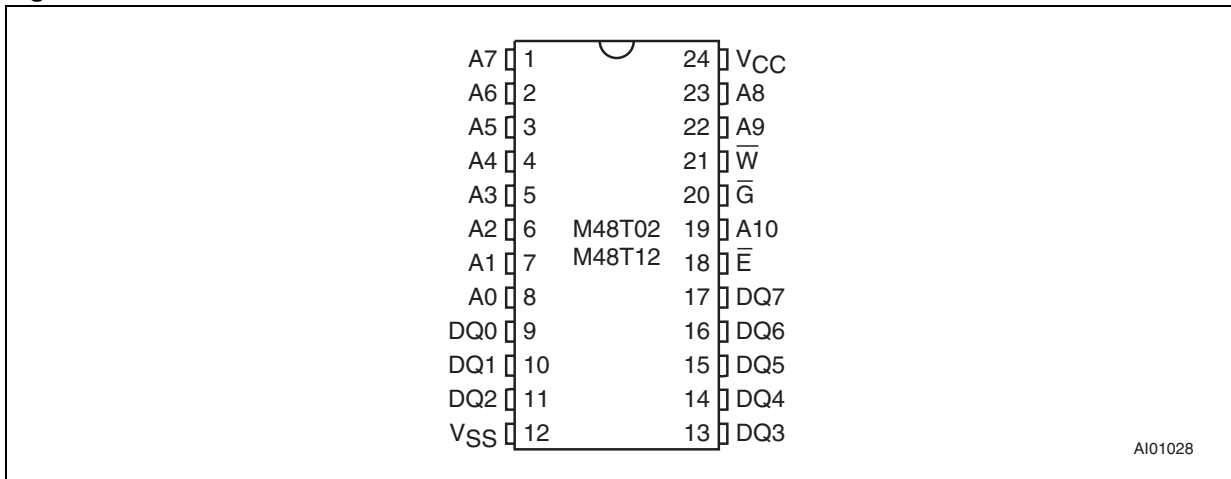
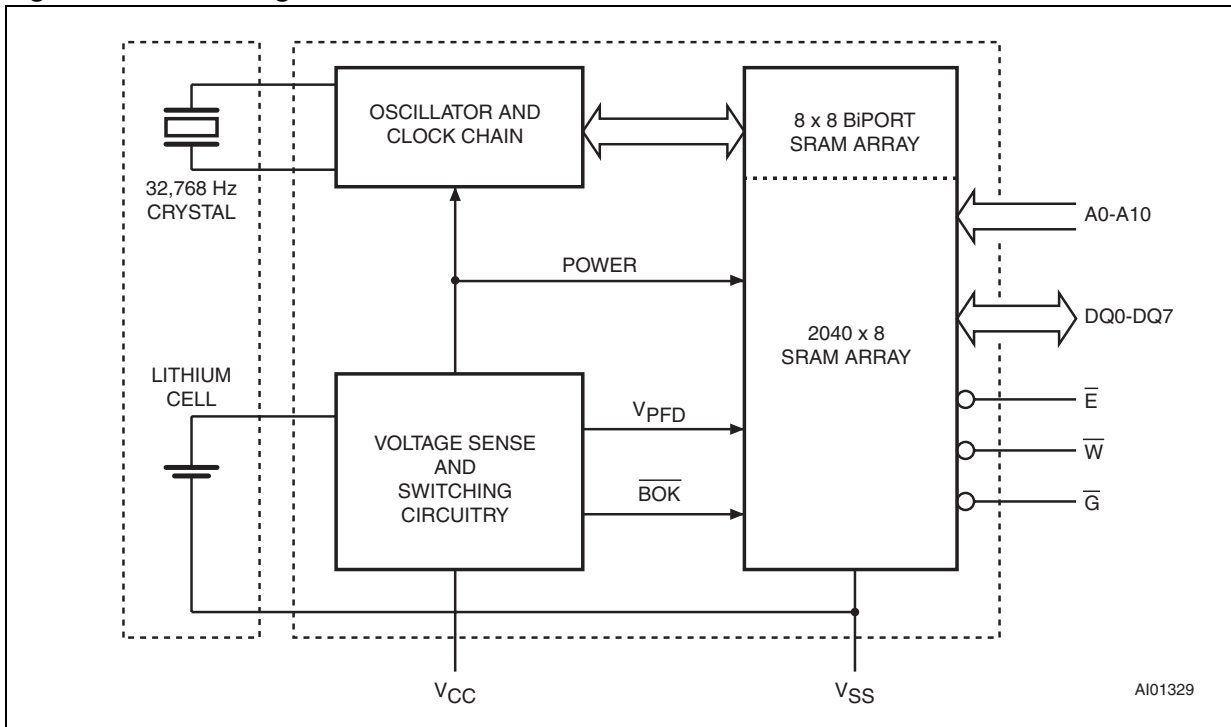

Figure 3. Block diagram



2 Operation modes

As [Figure 3 on page 6](#) shows, the static memory array and the quartz controlled clock oscillator of the M48T02/12 are integrated on one silicon chip. The two circuits are interconnected at the upper eight memory locations to provide user accessible BYTEWIDE™ clock information in the bytes with addresses 7F8h-7FFh. The clock locations contain the year, month, date, day, hour, minute, and second in 24-hour BCD format. Corrections for 28, 29 (leap year - valid until 2100), 30, and 31 day months are made automatically.

Byte 7F8h is the clock control register. This byte controls user access to the clock information and also stores the clock calibration setting.

The eight clock bytes are not the actual clock counters themselves; they are memory locations consisting of BiPORT™ READ/WRITE memory cells. The M48T02/12 includes a clock control circuit which updates the clock bytes with current information once per second. The information can be accessed by the user in the same manner as any other location in the static memory array.

The M48T02/12 also has its own power-fail detect circuit. The control circuitry constantly monitors the single 5 V supply for an out of tolerance condition. When V_{CC} is out of tolerance, the circuit write protects the SRAM, providing a high degree of data security in the midst of unpredictable system operation brought on by low V_{CC} . As V_{CC} falls below approximately 3 V, the control circuitry connects the battery which maintains data and clock operation until valid power returns.

Table 2. Operating modes

Mode	V_{CC}	\bar{E}	\bar{G}	\bar{W}	DQ0-DQ7	Power
Deselect	4.75 to 5.5 V or 4.5 to 5.5 V	V_{IH}	X	X	High Z	Standby
WRITE		V_{IL}	X	V_{IL}	D_{IN}	Active
READ		V_{IL}	V_{IL}	V_{IH}	D_{OUT}	Active
READ		V_{IL}	V_{IH}	V_{IH}	High Z	Active
Deselect	V_{SO} to $V_{PFD(min)}^{(1)}$	X	X	X	High Z	CMOS standby
Deselect	$\leq V_{SO}^{(1)}$	X	X	X	High Z	Battery backup mode

1. See [Table 11 on page 20](#) for details.

Note: $X = V_{IH}$ or V_{IL} ; V_{SO} = Battery backup switchover voltage.

2.1 READ mode

The M48T02/12 is in the READ mode whenever \bar{W} (WRITE enable) is high and \bar{E} (chip enable) is low. The device architecture allows ripple-through access of data from eight of 16,384 locations in the static storage array. Thus, the unique address specified by the 11 Address Inputs defines which one of the 2,048 bytes of data is to be accessed. Valid data will be available at the data I/O pins within address access time (t_{AVQV}) after the last address input signal is stable, providing that the \bar{E} and \bar{G} access times are also satisfied. If the \bar{E} and \bar{G} access times are not met, valid data will be available after the latter of the chip enable access time (t_{ELQV}) or output enable access time (t_{GLQV}).

The state of the eight three-state data I/O signals is controlled by \bar{E} and \bar{G} . If the outputs are activated before t_{AVQV} , the data lines will be driven to an indeterminate state until t_{AVQV} . If the address inputs are changed while \bar{E} and \bar{G} remain active, output data will remain valid for output data hold time (t_{AXQX}) but will go indeterminate until the next address access.

Figure 4. READ mode AC waveforms

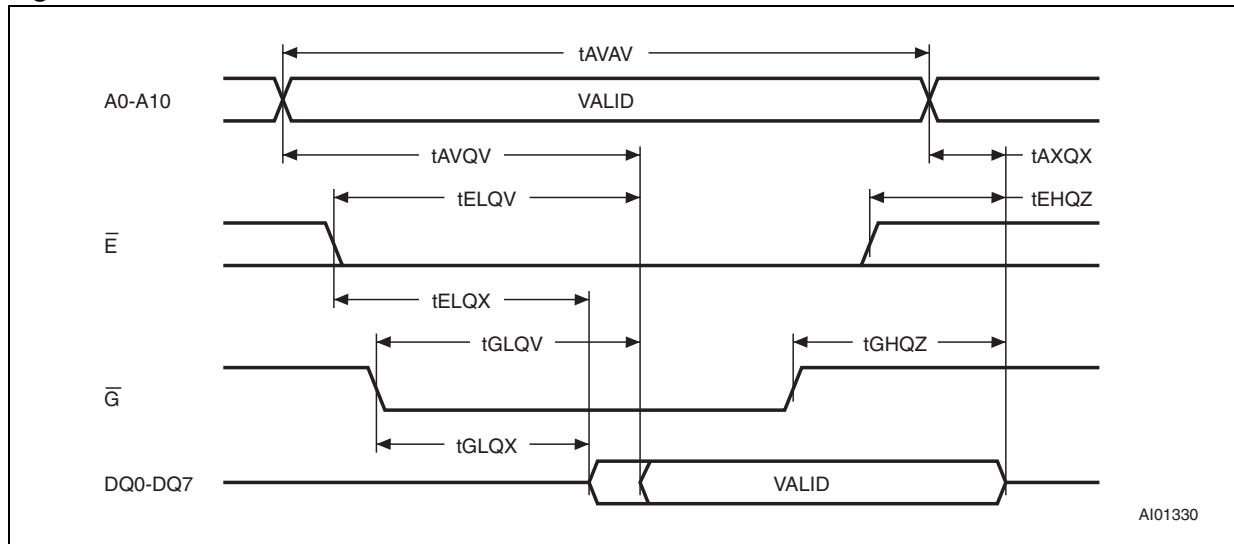

Note: WRITE enable (\bar{W}) = High.

Table 3. READ mode AC characteristics

Symbol	Parameter ⁽¹⁾	M48T02/M48T12						Unit
		-70		-150		-200		
		Min	Max	Min	Max	Min	Max	
t_{AVAV}	READ cycle time	70		150		200		ns
t_{AVQV}	Address valid to output valid		70		150		200	ns
t_{ELQV}	Chip enable low to output valid		70		150		200	ns
t_{GLQV}	Output enable low to output valid		35		75		80	ns
t_{ELQX}	Chip enable low to output transition	5		10		10		ns
t_{GLQX}	Output enable low to output transition	5		5		5		ns
t_{EHQZ}	Chip enable high to output Hi-Z		25		35		40	ns
t_{GHQZ}	Output enable high to output Hi-Z		25		35		40	ns
t_{AXQX}	Address transition to output transition	10		5		5		ns

1. Valid for ambient operating temperature: $T_A = 0$ to 70 °C; $V_{CC} = 4.75$ to 5.5 V or 4.5 to 5.5 V (except where noted).

2.2 WRITE mode

The M48T02/12 is in the WRITE mode whenever \overline{W} and \overline{E} are active. The start of a WRITE is referenced from the latter occurring falling edge of \overline{W} or \overline{E} . A WRITE is terminated by the earlier rising edge of \overline{W} or \overline{E} . The addresses must be held valid throughout the cycle. \overline{E} or \overline{W} must return high for a minimum of t_{EHAX} from chip enable or t_{WHAX} from WRITE enable prior to the initiation of another READ or WRITE cycle. Data-in must be valid t_{DVWH} prior to the end of WRITE and remain valid for t_{WHDX} afterward. \overline{G} should be kept high during WRITE cycles to avoid bus contention; although, if the output bus has been activated by a low on \overline{E} and \overline{G} , a low on \overline{W} will disable the outputs t_{WLQZ} after \overline{W} falls.

Figure 5. WRITE enable controlled, WRITE AC waveform

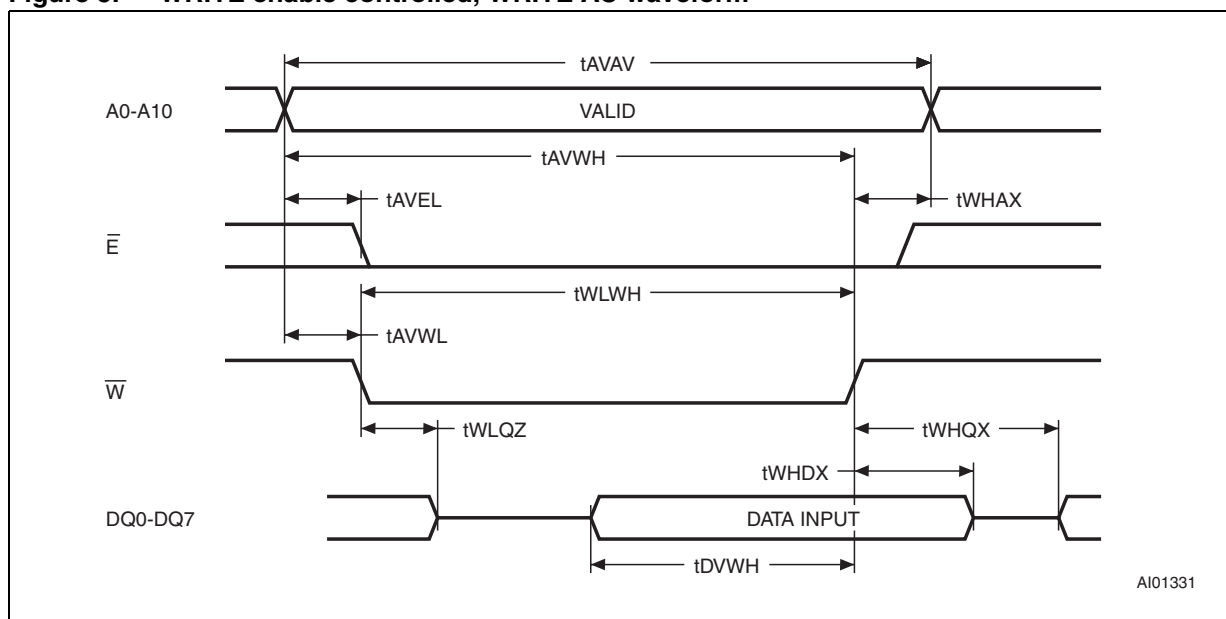

Figure 6. Chip enable controlled, WRITE AC waveforms

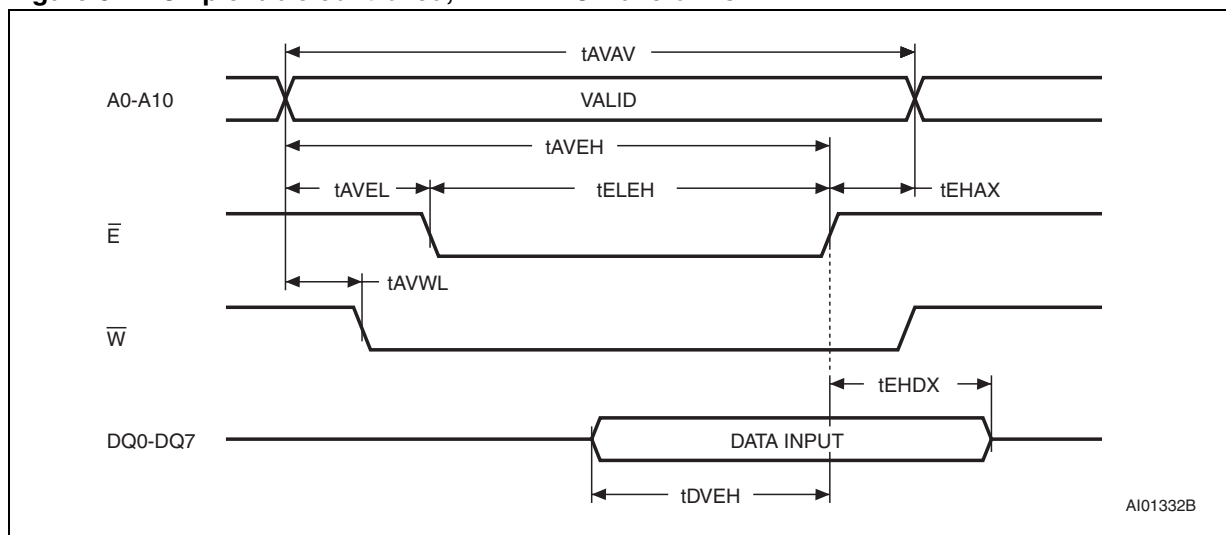

Table 4. WRITE mode AC characteristics

Symbol	Parameter ⁽¹⁾	M48T02/M48T12						Unit
		-70		-150		-200		
		Min	Max	Min	Max	Min	Max	
t _{AVAV}	WRITE cycle time	70		150		200		ns
t _{AVWL}	Address valid to WRITE enable low	0		0		0		ns
t _{AVEL}	Address valid to chip enable low	0		0		0		ns
t _{WLWH}	WRITE enable pulse width	50		90		120		ns
t _{ELEH}	Chip enable low to chip enable high	55		90		120		ns
t _{WHAX}	WRITE enable high to address transition	0		10		10		ns
t _{EHAX}	Chip enable high to address transition	0		10		10		ns
t _{DVWH}	Input valid to WRITE enable high	30		40		60		ns
t _{DVEH}	Input valid to chip enable high	30		40		60		ns
t _{WHDX}	WRITE enable high to input transition	5		5		5		ns
t _{EHDX}	Chip enable high to input transition	5		5		5		ns
t _{WLQZ}	WRITE enable low to output Hi-Z		25		50		60	ns
t _{AVWH}	Address valid to WRITE enable high	60		120		140		ns
t _{AVEH}	Address valid to chip enable high	60		120		140		ns
t _{WHQX}	WRITE enable high to output transition	5		10		10		ns

1. Valid for ambient operating temperature: T_A = 0 to 70 °C; V_{CC} = 4.75 to 5.5 V or 4.5 to 5.5 V (except where noted).

2.3 Data retention mode

With valid V_{CC} applied, the M48T02/12 operates as a conventional BYTEWIDE™ static RAM. Should the supply voltage decay, the RAM will automatically power-fail deselect, write protecting itself when V_{CC} falls within the V_{PFD} (max), V_{PFD} (min) window. All outputs become high impedance, and all inputs are treated as “don't care.”

Note: A power failure during a WRITE cycle may corrupt data at the currently addressed location, but does not jeopardize the rest of the RAM's content. At voltages below V_{PFD} (min), the user can be assured the memory will be in a write protected state, provided the V_{CC} fall time is not less than t_F. The M48T02/12 may respond to transient noise spikes on V_{CC} that reach into the deselect window during the time the device is sampling V_{CC}. Therefore, decoupling of the power supply lines is recommended.

The power switching circuit connects external V_{CC} to the RAM and disconnects the battery when V_{CC} rises above V_{SO}. As V_{CC} rises, the battery voltage is checked. If the voltage is too low, an internal battery not oK (BOK) flag will be set. The BOK flag can be checked after power up. If the BOK flag is set, the first WRITE attempted will be blocked. The flag is automatically cleared after the first WRITE, and normal RAM operation resumes. [Figure 7 on page 11](#) illustrates how a BOK check routine could be structured.

For more information on a battery storage life refer to the application note AN1012.

Figure 7. Checking the $\overline{\text{BOK}}$ flag status

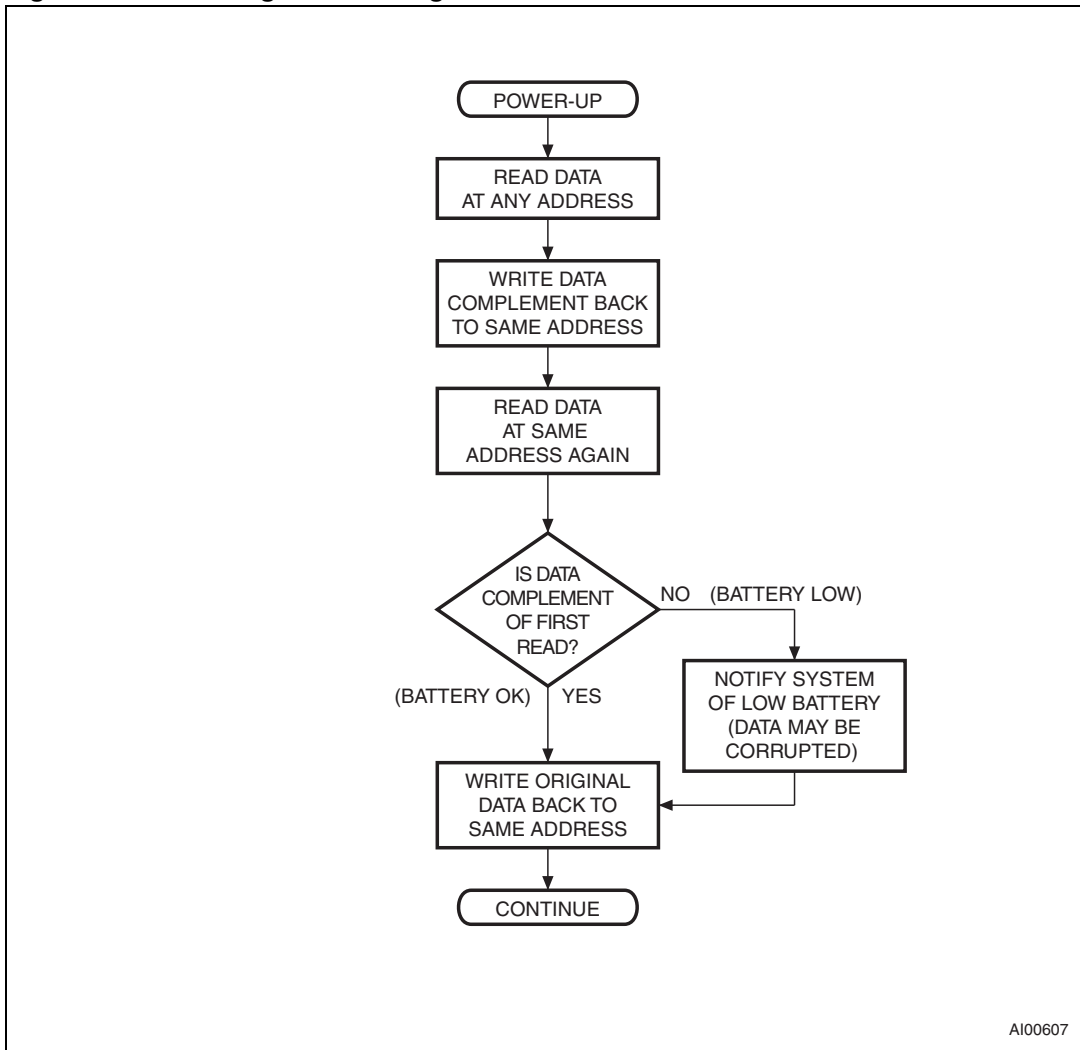

A100607

3 Clock operations

3.1 Reading the clock

Updates to the TIMEKEEPER® registers should be halted before clock data is read to prevent reading data in transition. The BiPORT™ TIMEKEEPER cells in the RAM array are only data registers and not the actual clock counters, so updating the registers can be halted without disturbing the clock itself.

Updating is halted when a '1' is written to the READ bit, the seventh bit in the control register. As long as a '1' remains in that position, updating is halted. After a halt is issued, the registers reflect the count; that is, the day, date, and the time that were current at the moment the halt command was issued.

All of the TIMEKEEPER registers are updated simultaneously. A halt will not interrupt an update in progress. Updating is within a second after the bit is reset to a '0.'

3.2 Setting the clock

The eighth bit of the control register is the WRITE bit. Setting the WRITE bit to a '1,' like the READ bit, halts updates to the TIMEKEEPER registers. The user can then load them with the correct day, date, and time data in 24-hour BCD format (on [Table 5 on page 13](#)). Resetting the WRITE bit to a '0' then transfers the values of all time registers (7F9-7FF) to the actual TIMEKEEPER counters and allows normal operation to resume. The FT bit and the bits marked as '0' in [Table 5 on page 13](#) must be written to '0' to allow for normal TIMEKEEPER and RAM operation.

See the application note AN923, "TIMEKEEPER® rolling into the 21st century" for information on century rollover.

Table 5. Register map

Address	Data								Function/range BCD format	
	D7	D6	D5	D4	D3	D2	D1	D0		
7FF	10 years				Year				Year	00-99
7FE	0	0	0	10 M	Month				Month	01-12
7FD	0	0	10 date		Date				Date	01-31
7FC	0	FT	0	0	0	Day			Day	01-07
7FB	0	0	10 hours		Hours				Hours	00-23
7FA	0	10 minutes			Minutes				Minutes	00-59
7F9	ST	10 seconds			Seconds				Seconds	00-59
7F8	W	R	S	Calibration				Control		

Keys:

S = SIGN bit

FT = FREQUENCY TEST bit (set to '0' for normal clock operation)

R = READ bit

W = WRITE bit

ST = STOP bit

0 = Must be set to '0'

3.3 Stopping and starting the oscillator

The oscillator may be stopped at any time. If the device is going to spend a significant amount of time on the shelf, the oscillator can be turned off to minimize current drain on the battery. The STOP bit is the MSB of the seconds register. Setting it to a '1' stops the oscillator. The M48T02/12 is shipped from STMicroelectronics with the STOP bit set to a '1.' When reset to a '0,' the M48T02/12 oscillator starts within one second.

3.4 Calibrating the clock

The M48T02/12 is driven by a quartz-controlled oscillator with a nominal frequency of 32,768 Hz. A typical M48T02/12 is accurate within 1 minute per month at 25°C without calibration. The devices are tested not to exceed ± 35 ppm (parts per million) oscillator frequency error at 25°C, which equates to about ± 1.53 minutes per month.

The oscillation rate of any crystal changes with temperature. [Figure 8 on page 15](#) shows the frequency error that can be expected at various temperatures. Most clock chips compensate for crystal frequency and temperature shift error with cumbersome "trim" capacitors. The M48T02/12 design, however, employs periodic counter correction. The calibration circuit adds or subtracts counts from the oscillator divider circuit at the divide by 256 stage, as shown in [Figure 9 on page 15](#). The number of times pulses are blanked (subtracted, negative calibration) or split (added, positive calibration) depends upon the value loaded into the five-bit calibration byte found in the control register. Adding counts speeds the clock up, subtracting counts slows the clock down.

The calibration byte occupies the five lower order bits in the control register. This byte can be set to represent any value between 0 and 31 in binary form. The sixth bit is the sign bit;

'1' indicates positive calibration, '0' indicates negative calibration. Calibration occurs within a 64 minute cycle. The first 62 minutes in the cycle may, once per minute, have one second either shortened by 128 or lengthened by 256 oscillator cycles. If a binary '1' is loaded into the register, only the first 2 minutes in the 64 minute cycle will be modified; if a binary 6 is loaded, the first 12 will be affected, and so on.

Therefore, each calibration step has the effect of adding 512 or subtracting 256 oscillator cycles for every 125,829,120 actual oscillator cycles; that is +4.068 or -2.034 ppm of adjustment per calibration step in the calibration register. Assuming that the oscillator is in fact running at exactly 32,768 Hz, each of the 31 increments in the calibration byte would represent +10.7 or -5.35 seconds per month which corresponds to a total range of +5.5 or -2.75 minutes per month.

Two methods are available for ascertaining how much calibration a given M48T02/12 may require. The first involves simply setting the clock, letting it run for a month and comparing it to a known accurate reference (like WWV broadcasts). While that may seem crude, it allows the designer to give the end user the ability to calibrate his clock as his environment may require, even after the final product is packaged in a non-user serviceable enclosure. All the designer has to do is provide a simple utility that accesses the calibration byte.

The second approach is better suited to a manufacturing environment, and involves the use of some test equipment. When the Frequency Test (FT) bit, the seventh-most significant bit in the day register, is set to a '1,' and the oscillator is running at 32,768 Hz, the LSB (DQ0) of the seconds register will toggle at 512 Hz. Any deviation from 512 Hz indicates the degree and direction of oscillator frequency shift at the test temperature. For example, a reading of 512.01024 Hz would indicate a +20 ppm oscillator frequency error, requiring -10 (WR001010) to be loaded into the calibration byte for correction.

Note: Setting or changing the calibration byte does not affect the frequency test output frequency. The device must be selected and addresses must be stable at address 7F9 when reading the 512 Hz on DQ0.

The FT bit must be set using the same method used to set the clock: using the WRITE bit. The LSB of the seconds register is monitored by holding the M48T02/12 in an extended READ of the seconds register, but without having the READ bit set. The FT bit MUST be reset to '0' for normal clock operations to resume.

Note: It is not necessary to set the WRITE bit when setting or resetting the frequency test bit (FT) or the stop bit (ST).

For more information on calibration, see the application note AN924, "TIMEKEEPER® calibration."

Figure 8. Crystal accuracy across temperature

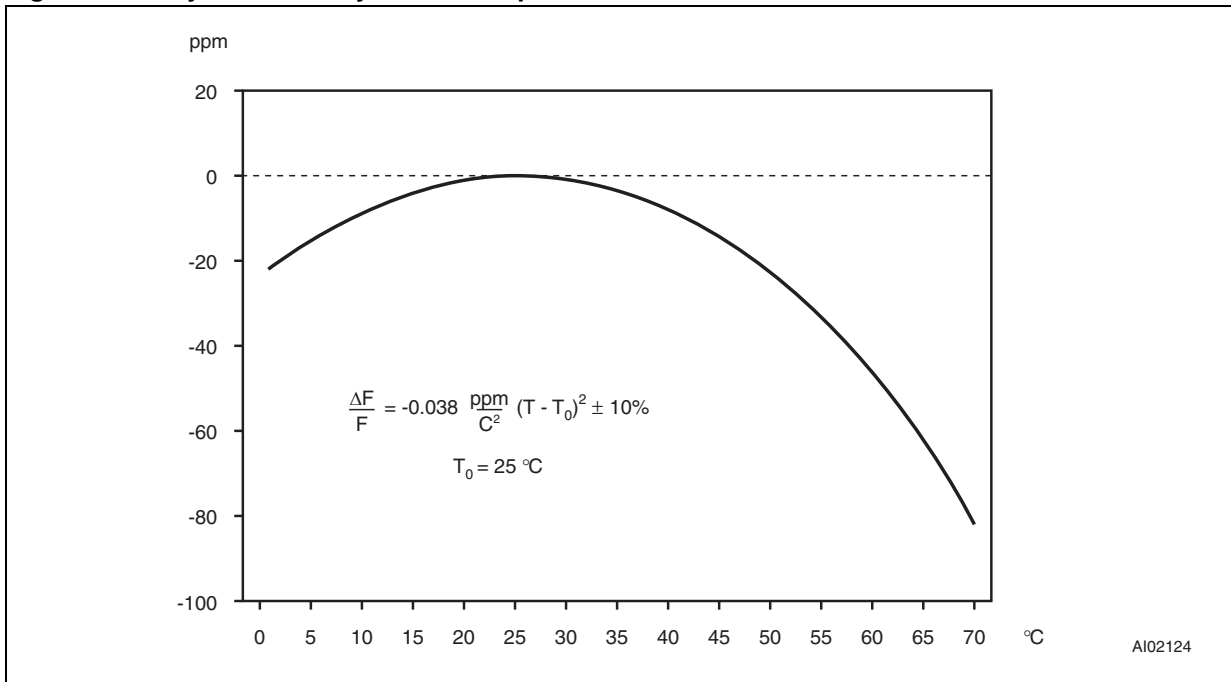
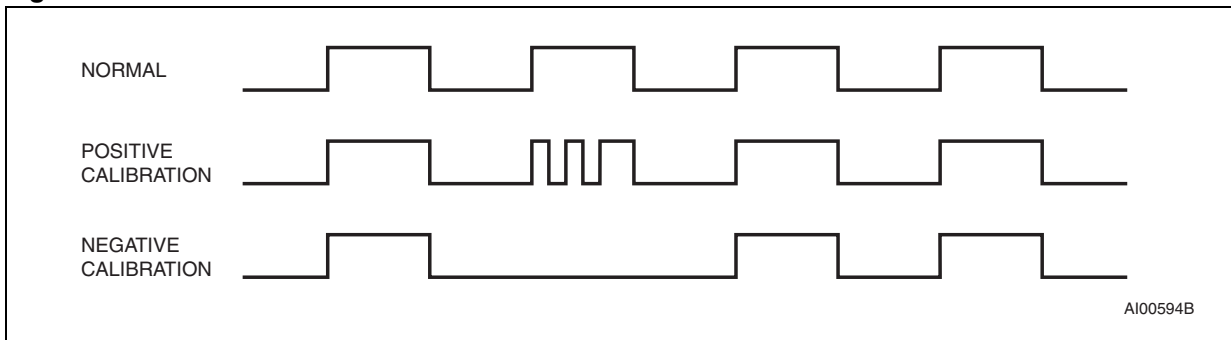

Figure 9. Clock calibration



3.5 V_{CC} noise and negative going transients

I_{CC} transients, including those produced by output switching, can produce voltage fluctuations, resulting in spikes on the V_{CC} bus. These transients can be reduced if capacitors are used to store energy which stabilizes the V_{CC} bus. The energy stored in the bypass capacitors will be released as low going spikes are generated or energy will be absorbed when overshoots occur. A ceramic bypass capacitor value of $0.1 \mu\text{F}$ (as shown in [Figure 10 on page 16](#)) is recommended in order to provide the needed filtering.

In addition to transients that are caused by normal SRAM operation, power cycling can generate negative voltage spikes on V_{CC} that drive it to values below V_{SS} by as much as one volt. These negative spikes can cause data corruption in the SRAM while in battery backup mode. To protect from these voltage spikes, it is recommended to connect a Schottky diode from V_{CC} to V_{SS} (cathode connected to V_{CC} , anode to V_{SS}). Schottky diode 1N5817 is recommended for through hole and MBR120T3 is recommended for surface mount.

Figure 10. Supply voltage protection

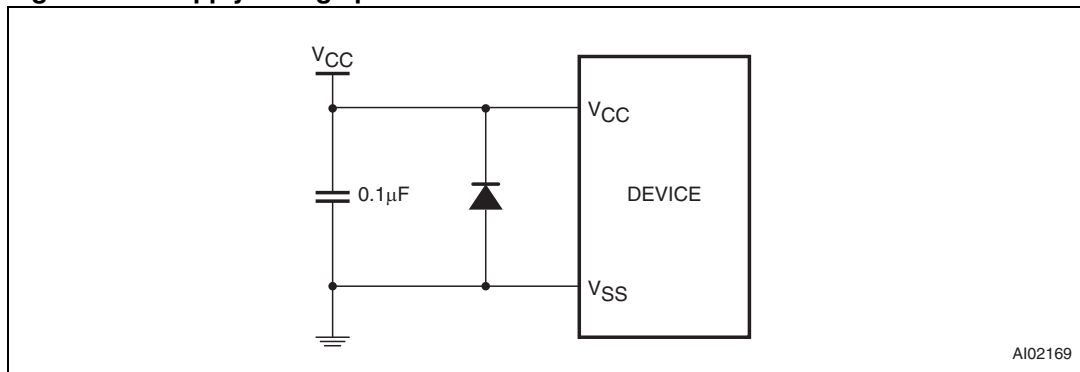

4 Maximum ratings

Stressing the device above the rating listed in the absolute maximum ratings table may cause permanent damage to the device. These are stress ratings only and operation of the device at these or any other conditions above those indicated in the operating sections of this specification is not implied. Exposure to absolute maximum rating conditions for extended periods may affect device reliability.

Table 6. Absolute maximum ratings

Symbol	Parameter	Value	Unit
T_A	Ambient operating temperature	0 to 70	°C
T_{STG}	Storage temperature (V_{CC} off, oscillator off)	-40 to 85	°C
$T_{SLD}^{(1)(2)}$	Lead solder temperature for 10 seconds	260	°C
V_{IO}	Input or output voltages	-0.3 to 7	V
V_{CC}	Supply voltage	-0.3 to 7	V
I_O	Output current	20	mA
P_D	Power dissipation	1	W

1. Soldering temperature of the IC leads is to not exceed 260 °C for 10 seconds. Furthermore, the devices shall not be exposed to IR reflow nor preheat cycles (as performed as part of wave soldering). ST recommends the devices be hand-soldered or placed in sockets to avoid heat damage to the batteries.
2. For DIP packaged devices, ultrasonic vibrations should not be used for post-solder cleaning to avoid damaging the crystal.

Caution: *Negative undershoots below -0.3 V are not allowed on any pin while in the battery backup mode.*

5 DC and AC parameters

This section summarizes the operating and measurement conditions, as well as the DC and AC characteristics of the device. The parameters in the following DC and AC characteristic tables are derived from tests performed under the measurement conditions listed in the relevant tables. Designers should check that the operating conditions in their projects match the measurement conditions when using the quoted parameters.

Table 7. Operating and AC measurement conditions

Parameter	M48T02	M48T12	Unit
Supply voltage (V_{CC})	4.75 to 5.5	4.5 to 5.5	V
Ambient operating temperature (T_A)	0 to 70	0 to 70	°C
Load capacitance (C_L)	100	100	pF
Input rise and fall times	≤ 5	≤ 5	ns
Input pulse voltages	0 to 3	0 to 3	V
Input and output timing ref. voltages	1.5	1.5	V

Note: Output Hi-Z is defined as the point where data is no longer driven.

Figure 11. AC testing load circuit

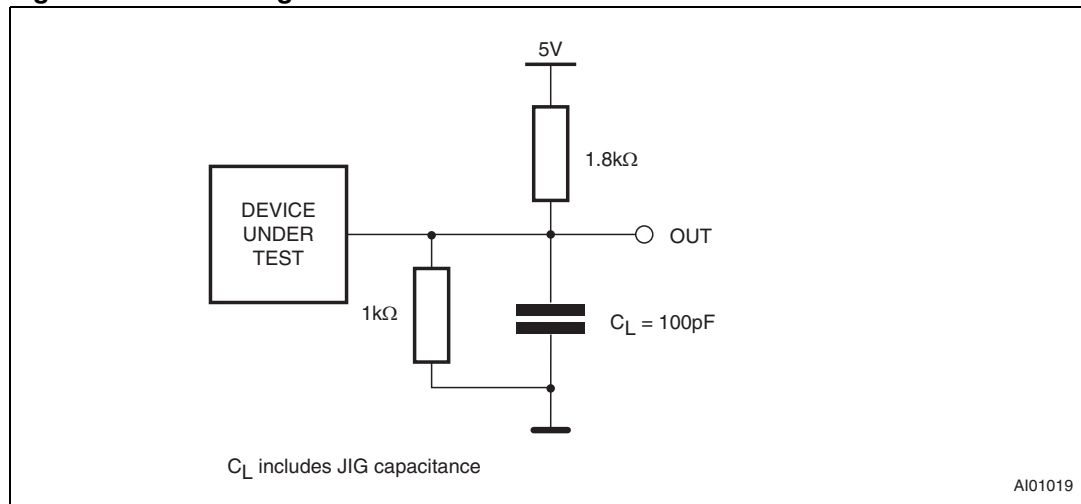

Table 8. Capacitance

Symbol	Parameter ⁽¹⁾⁽²⁾	Min	Max	Unit
C_{IN}	Input capacitance	-	10	pF
$C_{IO}^{(3)}$	Input / output capacitance	-	10	pF

1. Effective capacitance measured with power supply at 5 V. Sampled only, not 100% tested.
2. At 25 °C, $f = 1\text{ MHz}$.
3. Outputs deselected.

Table 9. DC characteristics

Symbol	Parameter	Test condition ⁽¹⁾	Min	Max	Unit
I_{LI}	Input leakage current	$0V \leq V_{IN} \leq V_{CC}$		± 1	μA
$I_{LO}^{(2)}$	Output leakage current	$0V \leq V_{OUT} \leq V_{CC}$		± 1	μA
I_{CC}	Supply current	Outputs open		80	mA
$I_{CC1}^{(3)}$	Supply current (standby) TTL	$\bar{E} = V_{IH}$		3	mA
$I_{CC2}^{(3)}$	Supply current (standby) CMOS	$\bar{E} = V_{CC} - 0.2 V$		3	mA
V_{IL}	Input low voltage		-0.3	0.8	V
V_{IH}	Input high voltage		2.2	$V_{CC} + 0.3$	V
V_{OL}	Output low voltage	$I_{OL} = 2.1 mA$		0.4	V
V_{OH}	Output high voltage	$I_{OH} = -1 mA$	2.4		V

- Valid for ambient operating temperature: $T_A = 0$ to $70^\circ C$; $V_{CC} = 4.75$ to $5.5 V$ or 4.5 to $5.5 V$ (except where noted).
- Outputs deselected.
- Measured with control bits set as follows: R = '1'; W, ST, FT = '0.'

Figure 12. Power down/up mode AC waveforms

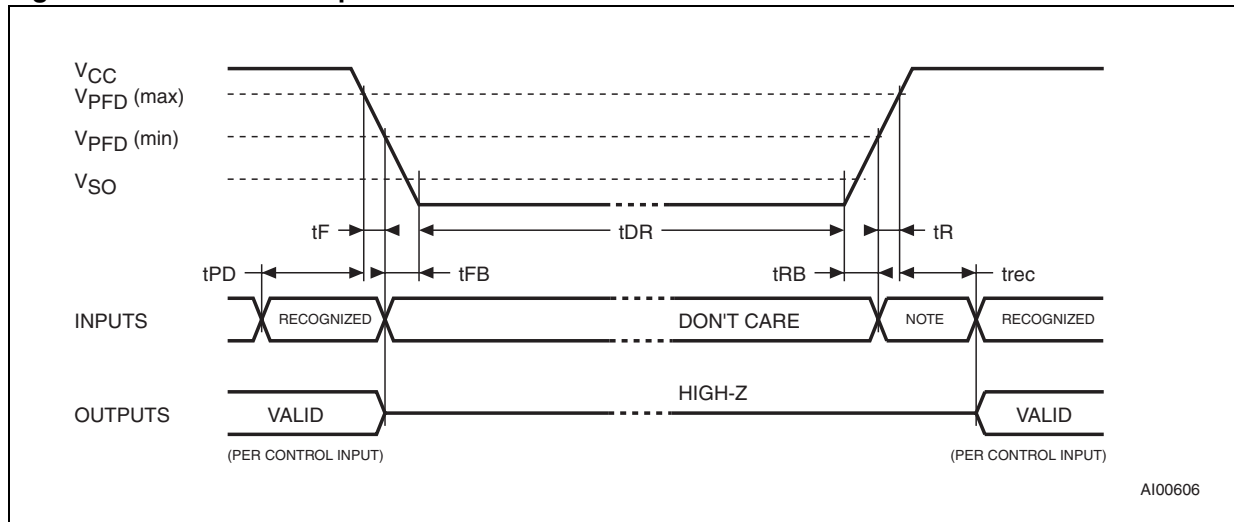

Note: Inputs may or may not be recognized at this time. Caution should be taken to keep \bar{E} high as V_{CC} rises past $V_{PFD} (min)$. Some systems may perform inadvertent WRITE cycles after V_{CC} rises above $V_{PFD} (min)$ but before normal system operations begin. Even though a power on reset is being applied to the processor, a reset condition may not occur until after the system clock is running.

Table 10. Power down/up AC characteristics

Symbol	Parameter ⁽¹⁾	Min	Max	Unit
t_{PD}	\overline{E} or \overline{W} at V_{IH} before power down	0	-	μs
$t_F^{(2)}$	V_{PFD} (max) to V_{PFD} (min) V_{CC} fall time	300	-	μs
$t_{FB}^{(3)}$	V_{PFD} (min) to V_{SS} V_{CC} fall time	10	-	μs
t_R	V_{PFD} (min) to V_{PFD} (max) V_{CC} rise time	0	-	μs
t_{RB}	V_{SS} to V_{PFD} (min) V_{CC} rise time	1	-	μs
t_{rec}	\overline{E} or \overline{W} at V_{IH} before power-up	2	-	ms

- Valid for ambient operating temperature: $T_A = 0$ to 70 °C; $V_{CC} = 4.75$ to 5.5 V or 4.5 to 5.5 V (except where noted).
- V_{PFD} (max) to V_{PFD} (min) fall time of less than t_F may result in deselection/write protection not occurring until 200 μs after V_{CC} passes V_{PFD} (min).
- V_{PFD} (min) to V_{SS} fall time of less than t_{FB} may cause corruption of RAM data.

Table 11. Power down/up trip points DC characteristics

Symbol	Parameter ⁽¹⁾⁽²⁾	Min	Typ	Max	Unit	
V_{PFD}	Power-fail deselect voltage	M48T02	4.5	4.6	4.75	V
		M48T12	4.2	4.3	4.5	V
V_{SO}	Battery backup switchover voltage		3.0		V	
$t_{DR}^{(3)}$	Expected data retention time	10			YEARS	

- All voltages referenced to V_{SS} .
- Valid for ambient operating temperature: $T_A = 0$ to 70 °C; $V_{CC} = 4.75$ to 5.5 V or 4.5 to 5.5 V (except where noted).
- At 25 °C; $V_{CC} = 0$ V.

6 Package mechanical data

In order to meet environmental requirements, ST offers these devices in different grades of ECOPACK[®] packages, depending on their level of environmental compliance. ECOPACK[®] specifications, grade definitions and product status are available at: www.st.com. ECOPACK[®] is an ST trademark.

Figure 13. PCDIP24 – 24-pin plastic DIP, battery CAPHAT™, package outline

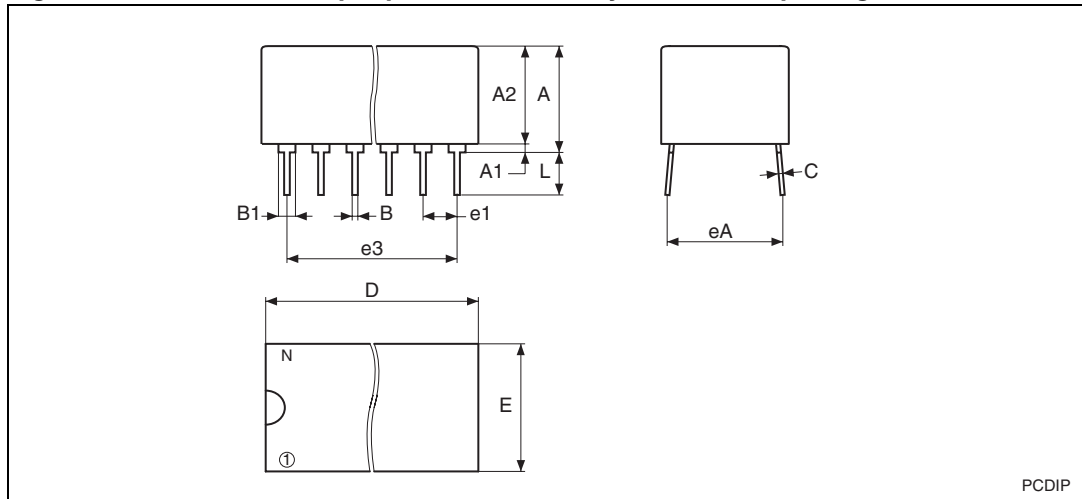

Note: Drawing is not to scale.

Table 12. PCDIP24 – 24-pin plastic DIP, battery CAPHAT™, package mech. data

Symb	mm			inches		
	Typ	Min	Max	Typ	Min	Max
A		8.89	9.65		0.350	0.380
A1		0.38	0.76		0.015	0.030
A2		8.38	8.89		0.330	0.350
B		0.38	0.53		0.015	0.021
B1		1.14	1.78		0.045	0.070
C		0.20	0.31		0.008	0.012
D		34.29	34.80		1.350	1.370
E		17.83	18.34		0.702	0.722
e1		2.29	2.79		0.090	0.110
e3	27.94			1.1		
eA		15.24	16.00		0.600	0.630
L		3.05	3.81		0.120	0.150
N		24			24	

7 Part numbering

Table 13. Ordering information scheme

Example:	M48T	02	-70	PC	1
Device type					
M48T					
Supply voltage and write protect voltage					
02 = $V_{CC} = 4.75$ to 5.5 V; $V_{PFD} = 4.5$ to 4.75 V					
12 = $V_{CC} = 4.5$ to 5.5 V; $V_{PFD} = 4.2$ to 4.5 V					
Speed					
-70 = 70 ns (M48T02/12)					
-150 = 150 ns (M48T02/12)					
-200 = 200 ns (M48T02/12) ⁽¹⁾					
Package					
PC = PCDIP24					
Temperature range					
1 = 0 to 70 °C					
Shipping method					
blank = ECOPACK [®] package, tubes					

1. Not recommended for new design. Contact ST sales office for availability.

For other options, or for more information on any aspect of this device, please contact the ST sales office nearest you.

8 Environmental information

Figure 14. Recycling symbols

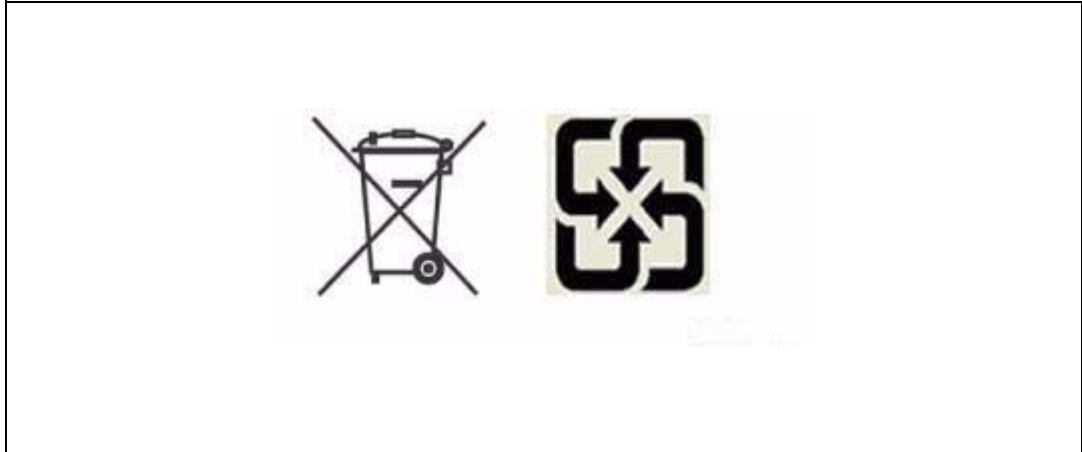

This product contains a non-rechargeable lithium (lithium carbon monofluoride chemistry) button cell battery fully encapsulated in the final product.

Recycle or dispose of batteries in accordance with the battery manufacturer's instructions and local/national disposal and recycling regulations.

9 Revision history

Table 14. Document revision history

Date	Revision	Changes
Jul-2000	1.0	First issue
13-Jul-2000	1.1	t_{rec} change (Table 10)
07-May-2001	2.0	Reformatted; temp. / voltage info. added to tables (Table 8, 9, 3, 4, 10, 11)
14-May-2001	2.1	Note added to clock calibration section; table footnote correction (Table 2)
16-Jul-2001	2.2	Basic formatting / content changes (cover page, Table 8, 9)
20-May-2002	2.3	Add countries to disclaimer
26-Jun-2002	2.4	Add footnote to table (Table 11)
28-Mar-2003	3.0	v2.2 template applied; test conditions updated (Table 10)
31-Mar-2004	4.0	Reformatted; lead-free (Pb-free) package information update (Table 6, 13)
12-Dec-2005	5.0	Updated template, lead-free text, removed footnote (Table 9, 13)
21-Sep-2007	6	Added lead-free second level interconnect information to cover page and Section 6: Package mechanical data .
13-Jan-2009	7	Added Section 8: Environmental information ; updated text in Section 6: Package mechanical data ; minor formatting changes.
02-Aug-2010	8	Reformatted document; updated Section 4, Table 12, 13 .
07-Jun-2011	9	Updated footnote 1 of Table 6: Absolute maximum ratings ; updated Section 8: Environmental information .

Please Read Carefully:

Information in this document is provided solely in connection with ST products. STMicroelectronics NV and its subsidiaries ("ST") reserve the right to make changes, corrections, modifications or improvements, to this document, and the products and services described herein at any time, without notice.

All ST products are sold pursuant to ST's terms and conditions of sale.

Purchasers are solely responsible for the choice, selection and use of the ST products and services described herein, and ST assumes no liability whatsoever relating to the choice, selection or use of the ST products and services described herein.

No license, express or implied, by estoppel or otherwise, to any intellectual property rights is granted under this document. If any part of this document refers to any third party products or services it shall not be deemed a license grant by ST for the use of such third party products or services, or any intellectual property contained therein or considered as a warranty covering the use in any manner whatsoever of such third party products or services or any intellectual property contained therein.

UNLESS OTHERWISE SET FORTH IN ST'S TERMS AND CONDITIONS OF SALE ST DISCLAIMS ANY EXPRESS OR IMPLIED WARRANTY WITH RESPECT TO THE USE AND/OR SALE OF ST PRODUCTS INCLUDING WITHOUT LIMITATION IMPLIED WARRANTIES OF MERCHANTABILITY, FITNESS FOR A PARTICULAR PURPOSE (AND THEIR EQUIVALENTS UNDER THE LAWS OF ANY JURISDICTION), OR INFRINGEMENT OF ANY PATENT, COPYRIGHT OR OTHER INTELLECTUAL PROPERTY RIGHT.

UNLESS EXPRESSLY APPROVED IN WRITING BY AN AUTHORIZED ST REPRESENTATIVE, ST PRODUCTS ARE NOT RECOMMENDED, AUTHORIZED OR WARRANTED FOR USE IN MILITARY, AIR CRAFT, SPACE, LIFE SAVING, OR LIFE SUSTAINING APPLICATIONS, NOR IN PRODUCTS OR SYSTEMS WHERE FAILURE OR MALFUNCTION MAY RESULT IN PERSONAL INJURY, DEATH, OR SEVERE PROPERTY OR ENVIRONMENTAL DAMAGE. ST PRODUCTS WHICH ARE NOT SPECIFIED AS "AUTOMOTIVE GRADE" MAY ONLY BE USED IN AUTOMOTIVE APPLICATIONS AT USER'S OWN RISK.

Resale of ST products with provisions different from the statements and/or technical features set forth in this document shall immediately void any warranty granted by ST for the ST product or service described herein and shall not create or extend in any manner whatsoever, any liability of ST.

ST and the ST logo are trademarks or registered trademarks of ST in various countries.

Information in this document supersedes and replaces all information previously supplied.

The ST logo is a registered trademark of STMicroelectronics. All other names are the property of their respective owners.

© 2011 STMicroelectronics - All rights reserved

STMicroelectronics group of companies

Australia - Belgium - Brazil - Canada - China - Czech Republic - Finland - France - Germany - Hong Kong - India - Israel - Italy - Japan - Malaysia - Malta - Morocco - Philippines - Singapore - Spain - Sweden - Switzerland - United Kingdom - United States of America

www.st.com

