

MICROCOMPUTER CONTROL CENTER
PART NO. 371-01200-004
FOR
MODEL YK L1 L1 G4 THRU YK S2 S2 J4 (STYLES A & B)
R-22 & R-134a
AND
MODEL YK LB LB G4 THRU YK SE SC J2 (STYLE C)
R-134a

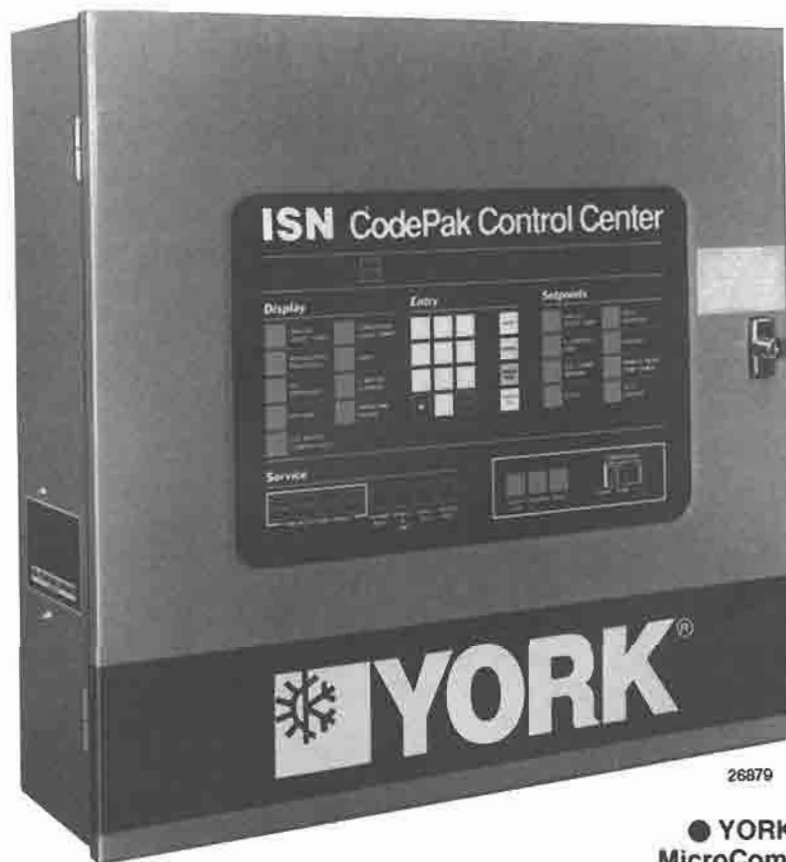

26879

● YORK
MicroComputer
Control Center

TABLE OF CONTENTS

SECTION 1	INTRODUCTION	3
SECTION 2	THEORY OF OPERATION	3
SECTION 3	COMPONENTS DESCRIPTIONS	8
SECTION 3A	DIGITAL INPUT BOARD	8
SECTION 3B	RELAY OUTPUT BOARD	12
SECTION 3C	POWER SUPPLY BOARD	16
SECTION 3D	MICRO BOARD	17
	Table 1 — Leaving Chilled Water Temp.	30
	Table 2 — Entering Chilled Water Temp.	33
	Table 3 — Oil and Discharge Temp.	35
	Table 4 — Entering and Leaving Cond. Water	48
SECTION 3E	DISPLAY	40
SECTION 3F	CM-2 CURRENT MODULE	41
SECTION 3G	REMOTE CURRENT LIMIT/LCWT SETPOINT BOARD	43
SECTION 3H	HIGH SPEED THRUST COLLAR POSITION AND DRAIN LINE TEMPERATURE SENSOR MODULE	47
SECTION 4	SYSTEM CALIBRATION, SPECIAL SETPOINTS AND RESET PROCEDURES	48
SECTION 5	TESTING	54
SECTION 6	TROUBLESHOOTING	56
	SYSTEM START-UP CHECKLIST	56
	TROUBLESHOOTING PROCEDURES	57

IMPORTANT

This instruction is intended to be used by certified (Qualified) Service personnel who have been instructed to service the MicroComputer Control Center. **Do not attempt to service this control center if you are not qualified.**

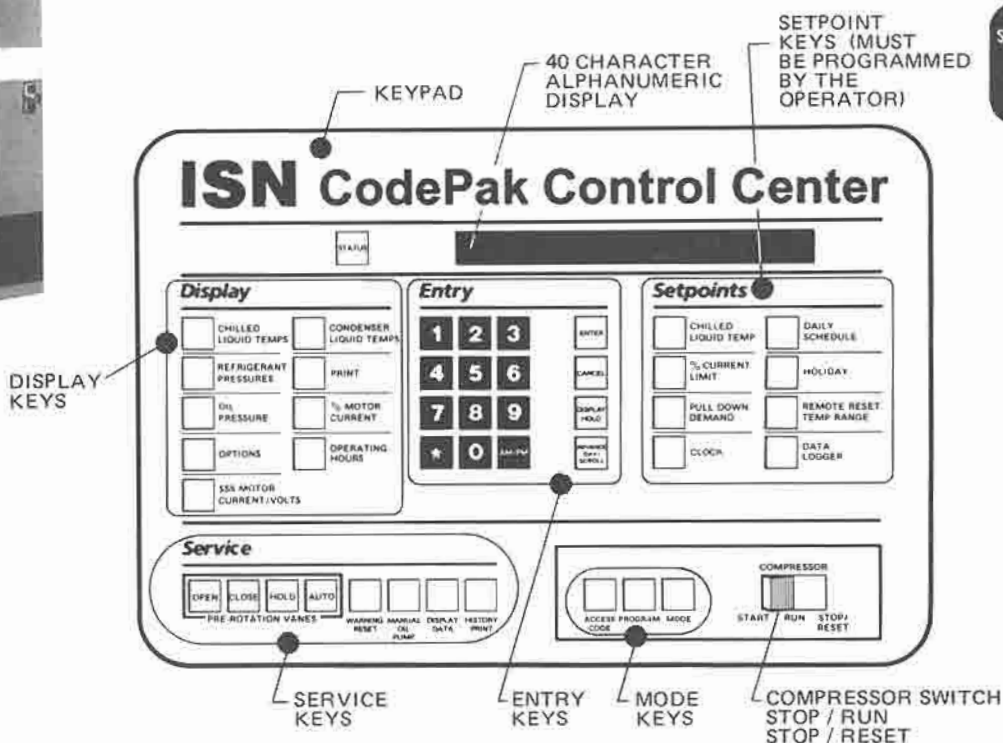

26879

FIG. 1 – MICROCOMPUTER CONTROL CENTER AND KEYPAD

SECTION 1 INTRODUCTION

This instruction is a description of the electronic operation, functional description of components and troubleshooting of the MicroComputer Control Center used to control the operation of a Codepak Centrifugal Liquid Chiller. This Control Center utilizes a YORK Liquid Cooled Solid State Starter, or an electro-mechanical starter.

The MicroComputer Control Center installation, operation, and display messages are described in Form

160.49-O1. This instruction is basically for the operator of the Codepak Liquid Chiller and does not include the technical operation of the control center, but should be used with this instruction by the field service technician qualified to perform the necessary service when needed.

This instruction should be read thoroughly before servicing the MicroComputer Control Center.

SECTION 2 THEORY OF OPERATION

OVERVIEW

The YORK MicroComputer Control Center is a microprocessor based control system for centrifugal chillers. It controls the leaving chilled water temperature via pre-rotation vane control and has the ability to limit motor current via control of the pre-rotation vanes. Fur-

ther, it is compatible with the Liquid Cooled Solid State Starter and electro-mechanical starter applications.

A front panel mounted keypad allows the operator to display system operating parameters on a 40 character alphanumeric display that is an inherent part of the keypad. These parameters are:

- chilled liquid temperatures
- refrigerant pressures
- differential oil pressure
- condenser liquid temperatures (optional)
- % FLA, motor current
- saturation temperatures
- discharge temperature
- oil temperature
- high & low oil pressure transducers
- operating hours/starts
- 3Ø motor current (Liquid Cooled Solid State Starter applications only)
- 3Ø line voltage (Liquid Cooled Solid State Starter applications only)

The system setpoints are operator entered on the front panel keypad. These setpoints can also be displayed on the 40 character alphanumeric display. The system setpoints are:

- leaving chilled liquid temperature
- % current limit
- pulldown demand limit
- clock (time-of-day, day of week, calendar date)
- daily schedule (7 day time-clock programming)
- holiday schedule
- remote reset temperature range
- chiller full load amps (Liquid Cooled Solid State Starter applications only.) Preset at factory, may be changed **only** by the qualified York Service Technician.
- undervoltage threshold (Liquid Cooled Solid State Starter applications only.)
- data logger—start time and print interval (optional—printer required) Ref. 160.49-N2

An optional printer can be used as a data logger to record all system parameters at an operator specified interval. Also, an operator can initiate this same print-out at any time by pressing a keypad key. Further, anytime the chiller shuts down on a safety or cycling shutdown, all system parameters valid at the time of shutdown and it's cause and time are printed. A history of the last four shutdowns is saved in memory and can be retrieved at any time by pressing the keypad **HISTORY PRINT** key. Refer to YORK Form 160.49-N2 for details of printer option.

A "Remote Chiller Communications" (York Guardian Service) option will be available in the future to allow personnel to receive chiller operating parameters upon request, or automatically, at a remote location. These parameters include system pressures, temperatures and setpoints.

An optional serial communications interface to the York FAX 4500 Energy Management System is also available. This allows two-way communication between the Micro-Computer Control Center and the FAX EMS.

The cause of any system shutdowns (safety or cycling) is preserved in the Micro Board's memory for subsequent viewing on the keypad display. Moreover, the operator is continually advised of system operating conditions by various background and warning messages. Finally, the keypad contains special service keys for use by the service technician when performing system troubleshooting.

The MicroComputer Control Panel is compatible with most energy management systems (EMS) in use today. The standard design allows for the following EMS interface:

- remote start
- remote stop
- remote LCWT setpoint (PWM signal)
- remote current limit setpoint (PWM signal)
- "remote mode ready to start" status contacts
- safety shutdown status contacts
- cycling shutdown status contacts

As an enhancement to the above standard EMS features, the customer may purchase optional plug-in PC boards that allow for remote LCWT setpoint and remote current limit setpoint interface in the following format:

- 4-20 MA
- 0-10 VDC
- contact closures

SYSTEM ARCHITECTURE

The microprocessor and supporting digital logic and analog circuits are contained on a single PC board known as the **Micro Board**. All system operating decisions are made on this board; such as when to open or close the vanes, when to run the oil pump, when to shut down on safety shutdowns, etc. Therefore, all system inputs and outputs must pass through this board. However, since the Micro Board's digital logic is +5 VDC, the 115 VAC inputs must be signal conditioned prior to application to the Micro Board. Similarly, the outputs must be relay isolated in order to drive the system 115 VAC relays and solenoids. These functions are performed by the digital input board and relay output-board respectively.

The **Digital Input Board** accepts 115 VAC inputs from system relays and external devices such as chilled water pump interlocks, local/remote cycling devices, EMS and vane motor switch, etc. These 0 VAC/115 VAC input signals are converted to 0 VDC/ + 5 VDC logic level signals for use by the Micro Board. The output of the Digital Input Board is interfaced directly to the Micro Board.

The Micro Board output interfaces directly to the **Relay Output Board**. The outputs of the Micro Board energize or de-energize DC relays on the relay output board. The

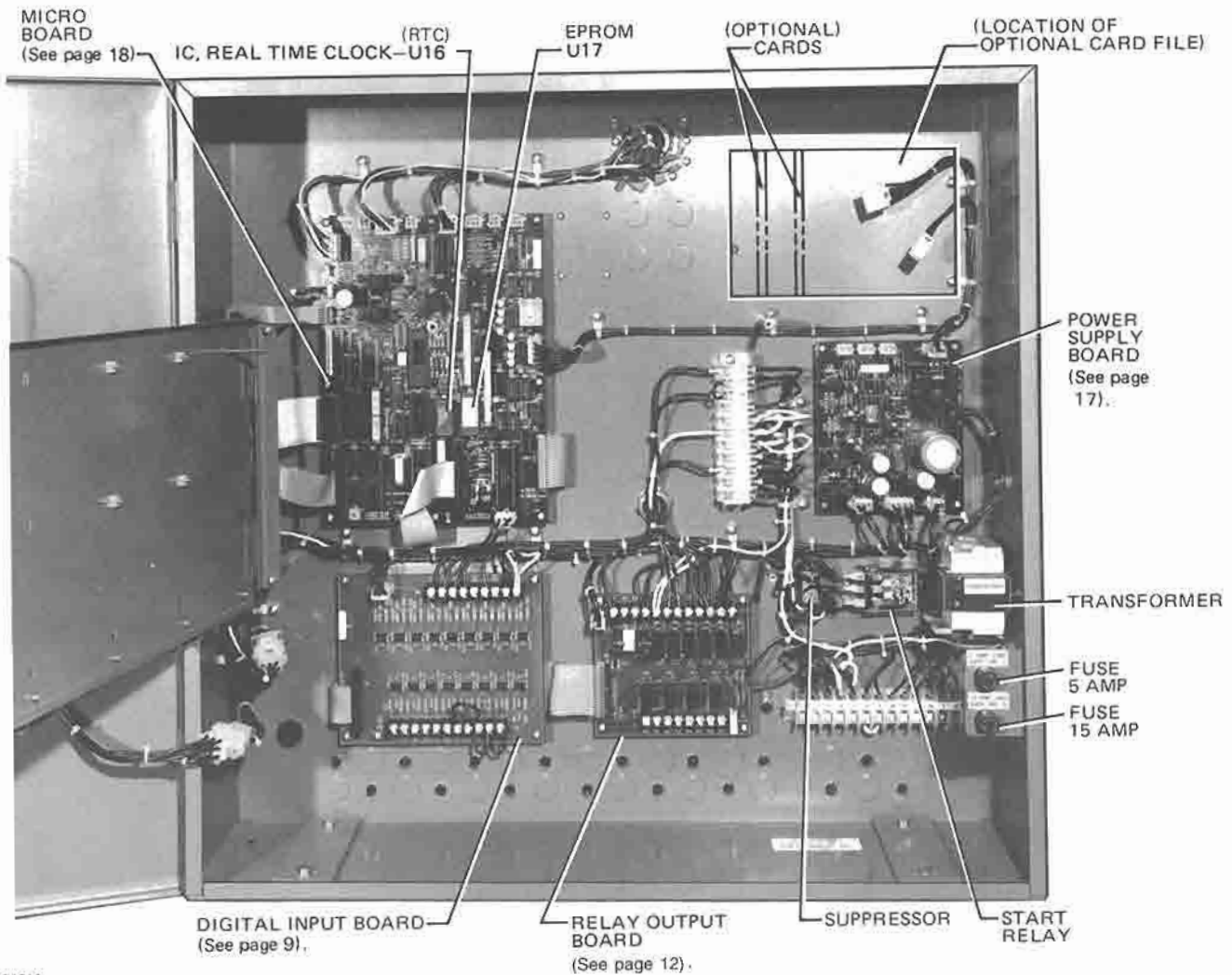

24618

FIG. 2 — MICROCOMPUTER CONTROL CENTER — DOOR AND HINGED PANEL OPEN

contacts of these relays energize or de-energize the system 115 VAC solenoids and relays. Also, the EMS remote status contacts are located on this board.

System pressures are sensed by **transducers**. System temperatures are sensed by **thermistors**. The transducers and thermistors are input to the Micro Board where multiplexing allows sharing of a single analog to digital converter. The digital words are compared to stored safety threshold values and, if exceeded, the Micro Board initiates a chiller shutdown.

DC power is supplied to all circuit boards by a **Power Supply Board**. AC power is supplied to the power supply board via a 115VAC to 24VAC stepdown transformer.

Applications

The MicroComputer Control Center is used on electro-mechanical or YORK Solid State Starter applications.

When the Control Center is used on **Electro-Mechanical Starter** applications, it performs both LCWT and current limit control. A CM-2 module (located inside the micro panel) is provided to perform compressor motor overload and power fault protection. Also, the CM-2 module provides motor current values to the Micro Board that is displayed as % of FLA.

When the control panel is used on **Liquid Cooled Solid State Starter** applications, it performs both LCWT and current limit control. The solid state starter logic board is provided inside the MicroComputer Control Center. It performs compressor motor overload and power fault protection in addition to solid state starter control functions. Also, it provides 3 phase power line voltage and compressor motor current values to the Micro Board for low line voltage and current unbalance protection and front panel display.

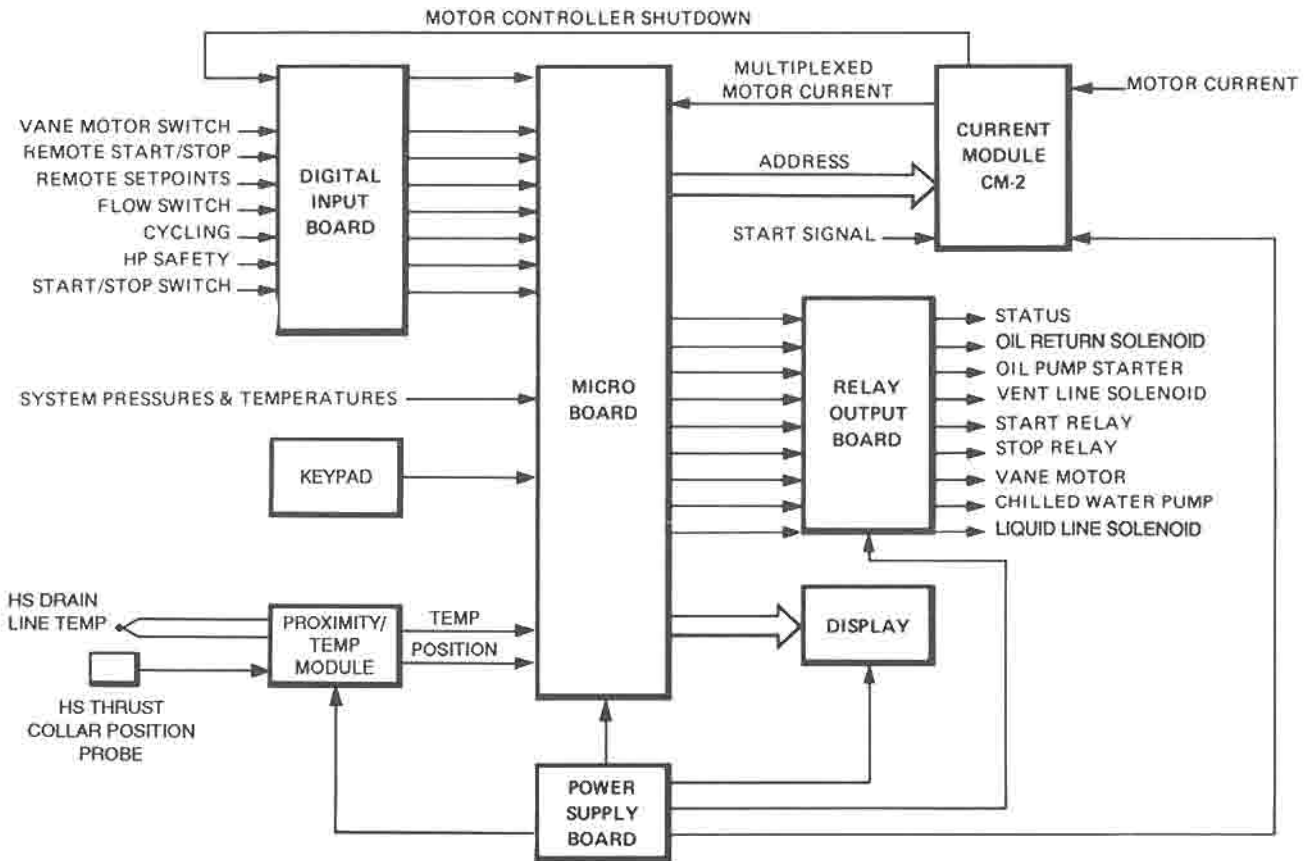
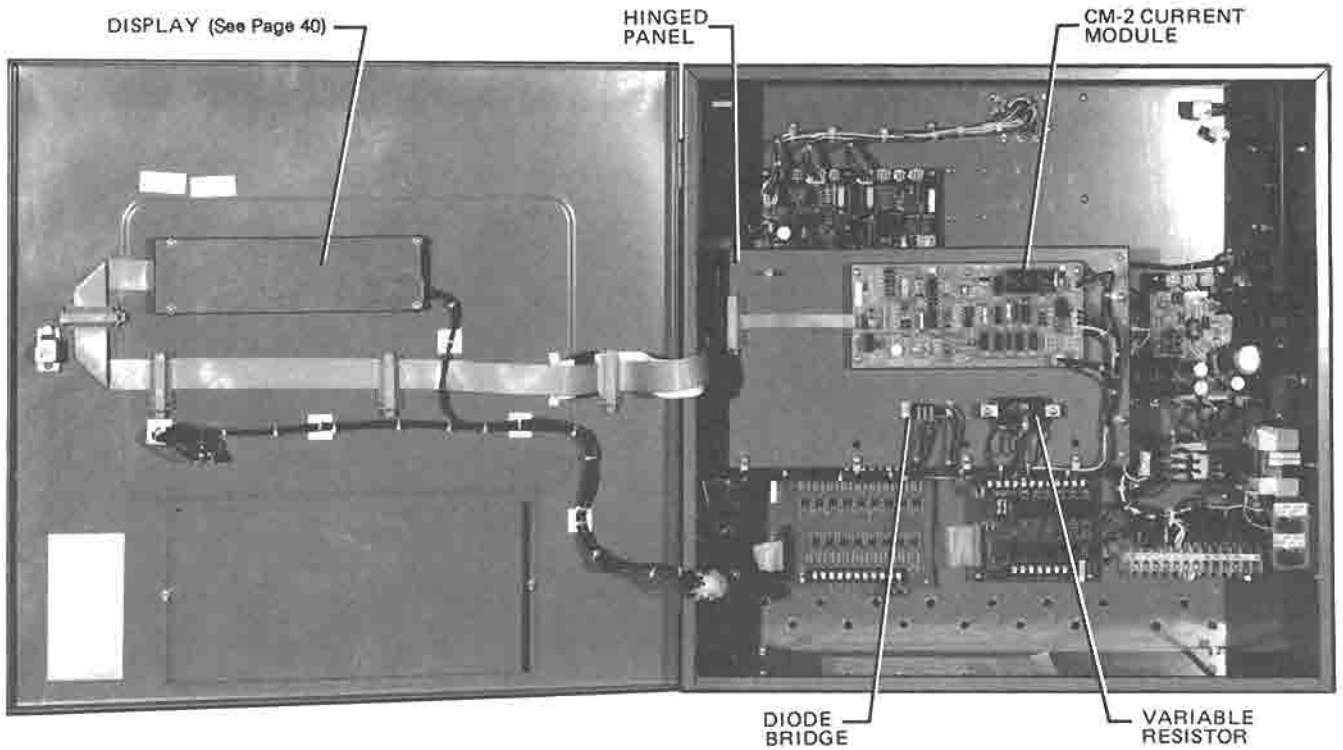

BLOCK DIAGRAM

24676
FIG. 3 — MICROCOMPUTER CONTROL CENTER — DOOR OPEN — ELECTRO-MECHANICAL STARTER APPLICATIONS

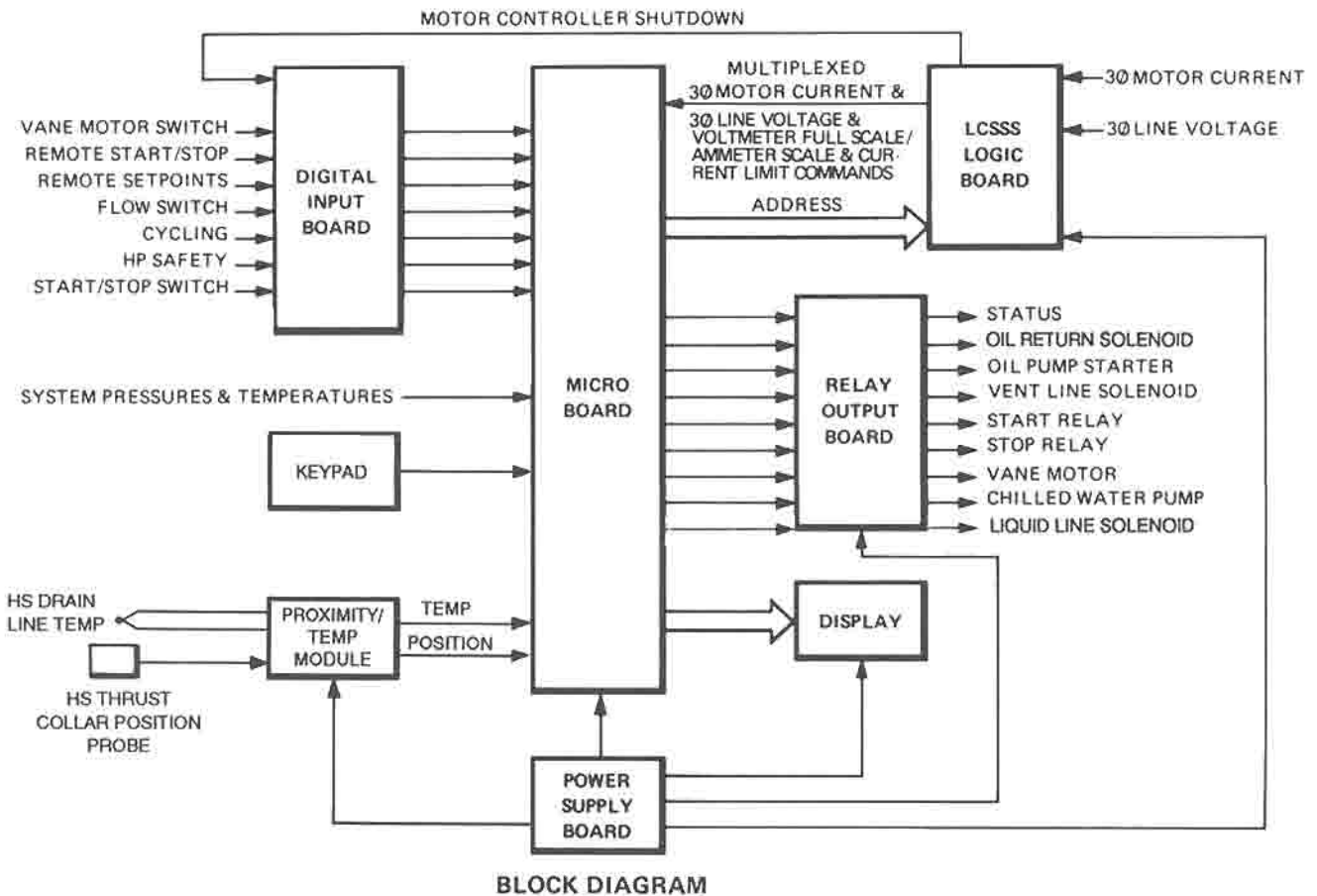
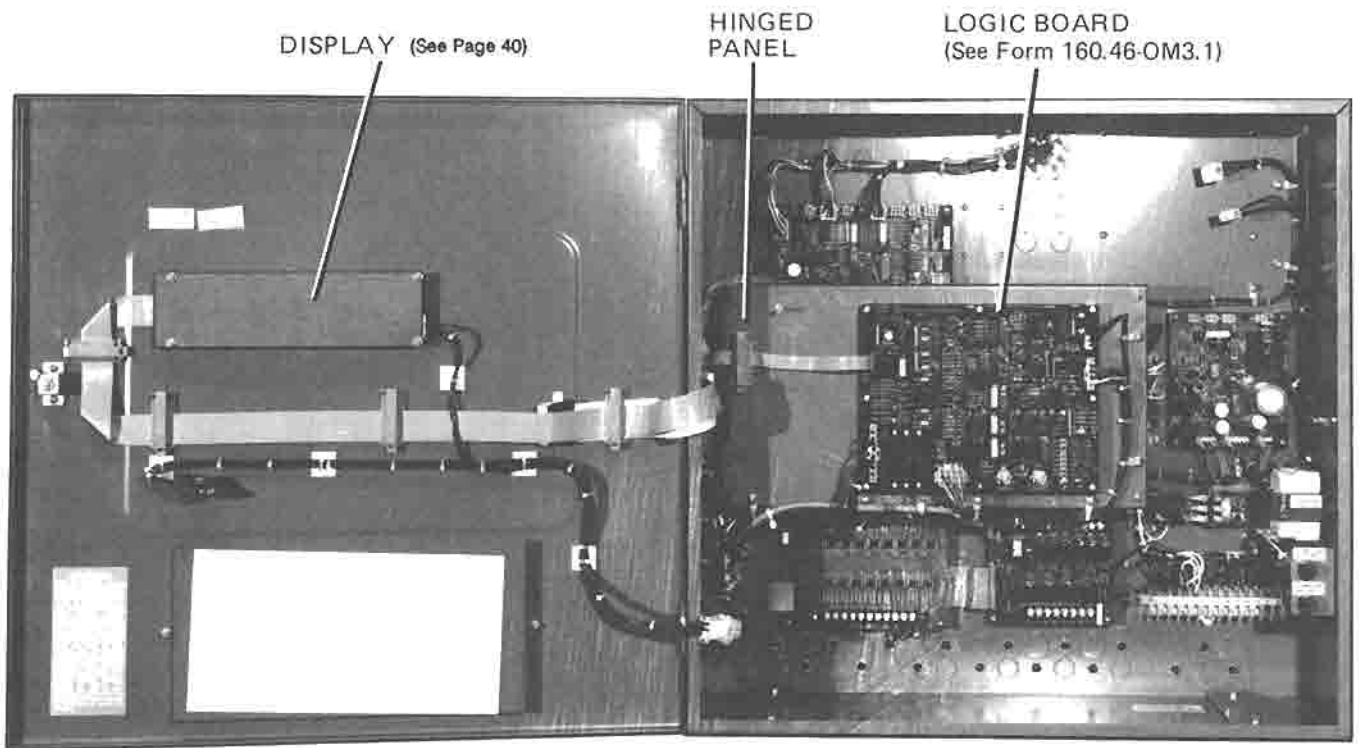

24670

FIG. 4 — MICROCOMPUTER CONTROL CENTER — DOOR OPEN — SOLID STATE STARTER APPLICATIONS

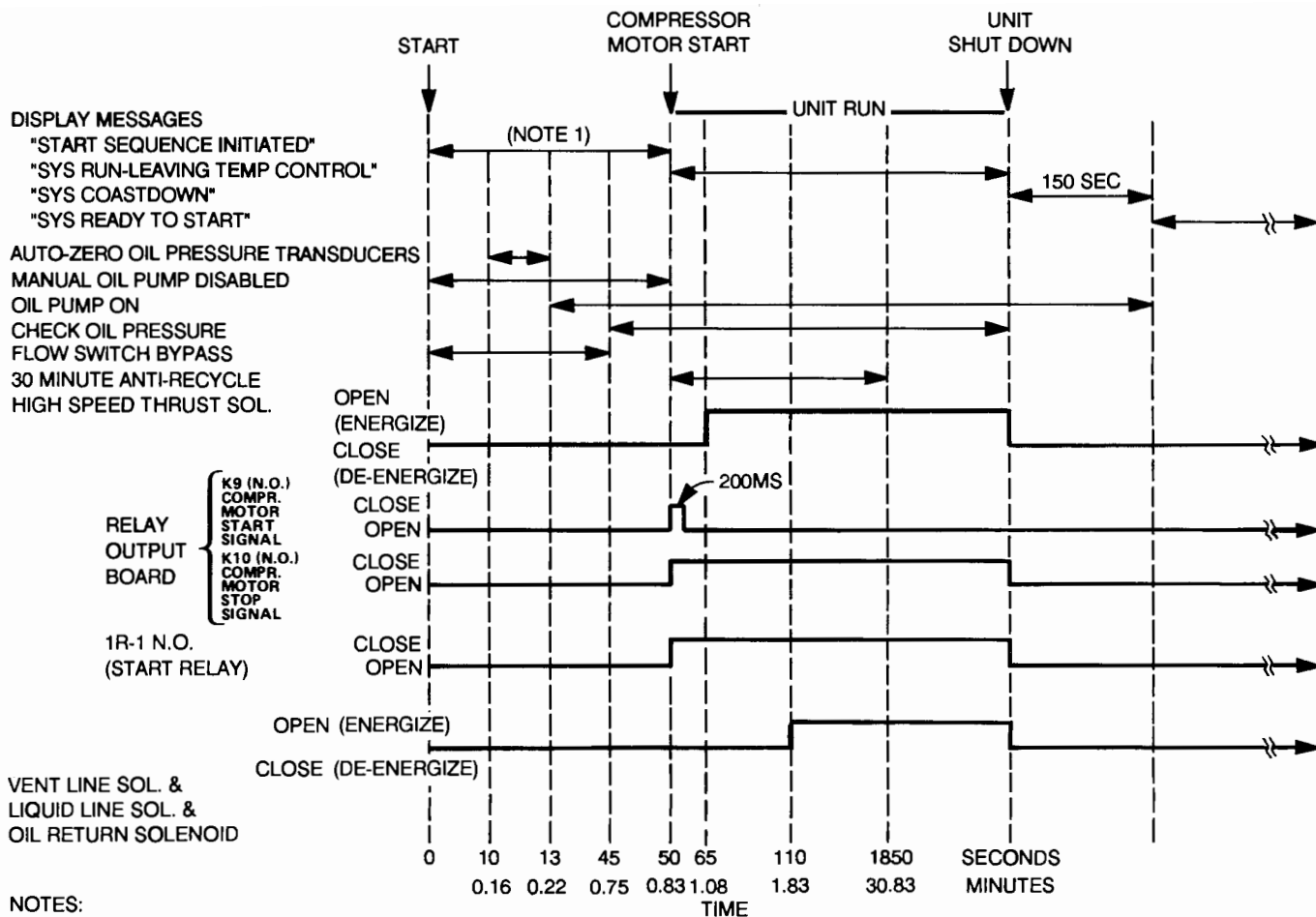

FIG. 5 – CODEPAK CHILLER STARTING SEQUENCE & SHUTDOWN SEQUENCE

SECTION 3 COMPONENT DESCRIPTIONS

SECTION 3A DIGITAL INPUT BOARD

(Ref. Fig. 6, 7, 8 and 9)

The Digital Input Board converts 115 VAC signals to +5VDC logic level signals for use by the Micro Board.

When the digital input device in question closes, the 115 VAC input is applied to a full wave rectifier. This unfiltered DC is then applied to an opto-coupler that turns on and allows the full +5VDC to be dropped across the output resistor. In summary, the input switch closure supplies a 115 VAC input which produces a +5VDC output; an open input produces a 0VDC output.

Terminal Strip TB2 is provided on the Digital Input Board for interfacing external customer signals (flow switch, multi-unit sequence, etc.). The signal input terminals are grouped together (according to function) with a 115 VAC power source terminal (1). The power source terminal (1) supplies source voltage for externally located

relay contacts - such as: the chilled water pump interlock/flow switch terminal (12) located adjacent to a terminal (1). Since terminal (1) is internally connected to 115 VAC on the **Digital Input Board**, the flow switch contacts would be connected between (12) and (1). When the flow switch contacts close, 115 VAC is applied to input terminal (12) causing the **Digital Input Board** output J1-19 to transition from 0VDC to +5VDC. The output will remain at +5VDC as long as the flow switch is closed.

Terminal Strip TB1 is provided for interfacing YORK supplied components that are located on the chiller (vane motor switch, high pressure safety switch, low evaporator pressure switch, (Brine units only).

Connector J2 is provided to interface the motor controller contacts and keypad COMPRESSOR switch to the Digital Input Board.

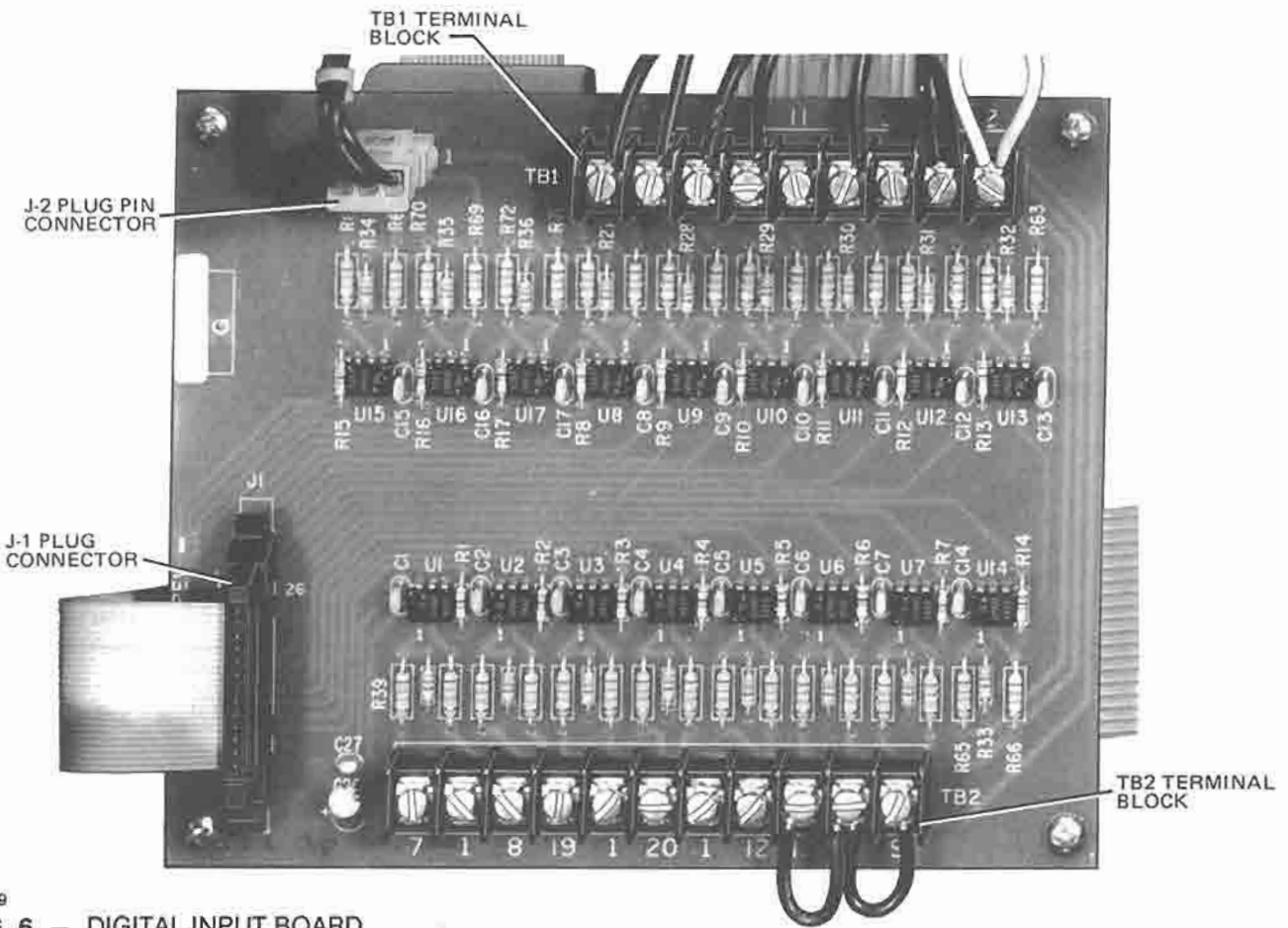

24679
FIG. 6 — DIGITAL INPUT BOARD

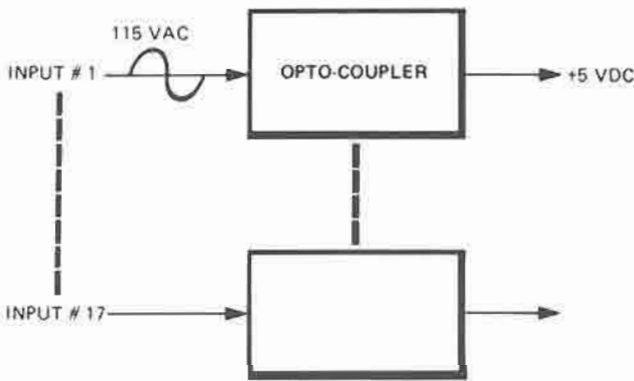

FIG. 7 — DIGITAL INPUT BOARD SIMPLIFIED BLOCK DIAGRAM

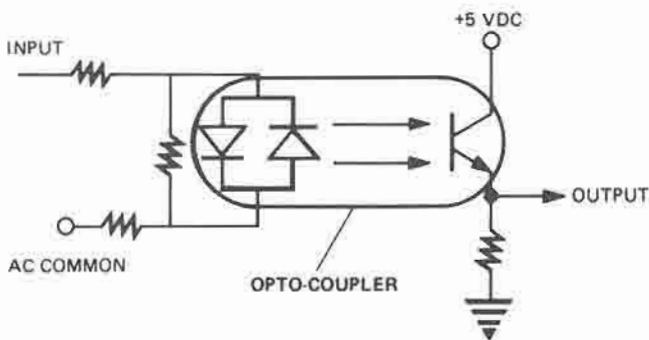

FIG. 8 — DETAILED SCHEMATIC REPRESENTATION DIGITAL INPUT-BOARD

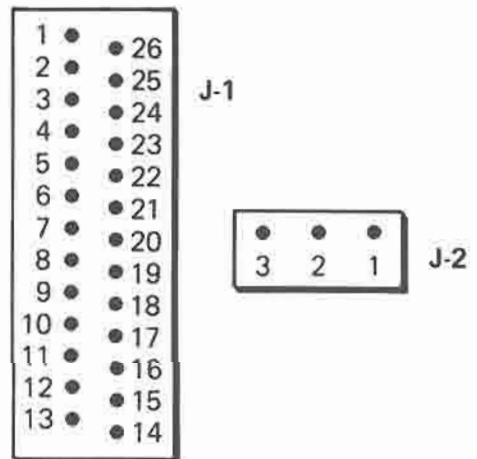

FIG. 9 — DIGITAL INPUT BOARD-PIN IDENTIFICATION

Connector J1 is provided to connect the logic level outputs of the Digital Input Board to the Micro Board via ribbon cable.

DIGITAL INPUT BOARD — INPUTS

J2-1 — Motor controller contacts (CM) input. From current module (CM-2) or Liquid Cooled Solid State Starter. 0VAC when motor controller has initiated a shutdown. When motor controller has reset, input goes to 115 VAC. Typically, the motor controller device must be manually

reset to clear this signal. However, the following motor controller shutdowns do not require an external reset:

Liquid Cooled Solid State Starter — High temp (>110°F), trigger OOL, phase rot/loss, power fault and half phase.

Electro-Mechanical Starter — (Current Module-CM2) — power fault.

When the motor controller device has detected a "Power Fault", the motor controller contacts will open and reclose in less than 3 seconds. Any reclosure in less than 3 seconds will be interpreted by the control center as a power fault. Power fault shutdowns do not require an external reset before restarting chiller; the chiller automatically restarts.

J2-2 — Compressor switch "STOP" position input. 115 VAC when switch is in "STOP" position, otherwise 0VAC.

J2-3 — Compressor switch "START" position input. 115VAC when switch is in "START" position, otherwise 0VAC.

TB1 – TERMINAL BLOCK

TB1-71 — Not used.

TB1-70 — Not used.

TB1-32 — High pressure safety input. This function is provided by a pressure control mounted on the condenser shell. 115 VAC when condenser pressure rises to 265 PSIG. High pressure safety device resets when condenser pressure falls to 205 PSIG.

TB1-18 — Vane motor switch input. 115VAC when vanes are fully closed.

TB1-11 — Not used.

TB1-10—Low evaporator pressure safety input on brine applications only. 0 VAC when external LEP safety device senses a low pressure situation, otherwise, 115 VAC. The actual trip setting of the safety device is determined by the specific application.

TB1-31—Auxilliary safety shutdown input. This input is used as a general purpose safety shutdown input available for customer use. Apply 115 VAC to initiate a shutdown. Ref. Fig. 10.

TB1-1—115 VAC input from Control Center AC power.

TB1-2—115 VAC neutral input from Control Center AC power.

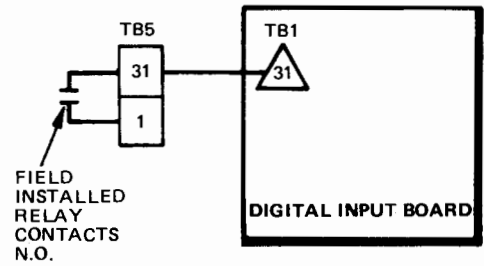

FIG. 10 – AUXILIARY SAFETY SHUTDOWN INPUT - TYPICAL APPLICATION

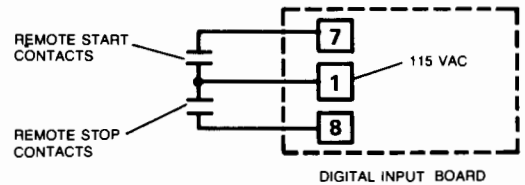

FIG. 11 – REMOTE START AND STOP UNITS

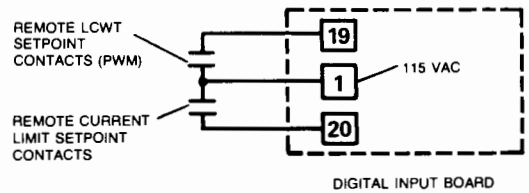

FIG. 12 – REMOTE LCWT & CURRENT LIMIT SET-POINT INPUTS (PWM)

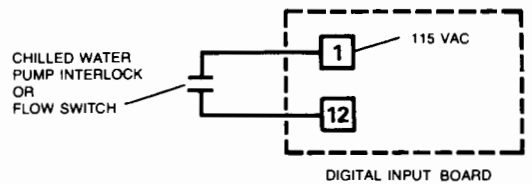
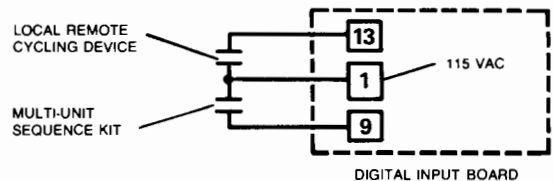
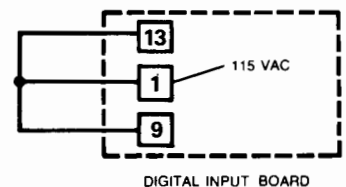

FIG. 13 – CHILLED WATER PUMP INTERLOCK OR FLOW SWITCH CONTACTS



DETAIL A



NO LOCAL OR REMOTE CYCLING OR MULTI UNIT SEQUENCE

DETAIL B

FIG. 14 – LOCAL REMOTE CYCLE DEVICE & MULTI-UNIT SEQUENCE KIT INPUTS

TB2—TERMINAL BLOCK

TB2-7 — Remote start input from external Energy Management System (EMS). Input designed to accept 115 VAC from external field supplied contacts to start compressor. Input will only be accepted if Control Center is in **REMOTE** mode and panel "**COMPRESSOR**" switch is in **RUN** mode. Refer to Fig. 11. This signal need only be a momentary signal to initiate a start, but a maintained closure is recommended.

TB2-1 — Connected to 115 VAC on Digital Input Board. Source voltage for remote start and remote stop inputs. Refer to Fig. 11.

TB2-8—Remote stop input from external Energy Management System (EMS). Input designed to accept 115 VAC from external field supplied contacts to stop compressor. Input will only be accepted if Control Center is in **REMOTE** mode and panel "**COMPRESSOR**" switch is in the **RUN** mode. Refer to Fig. 11. This signal must be a maintained signal to provide a stop function.

TB2-19—Remote LCWT setpoint from external Energy Management System (EMS). Signal is a 1-11 SEC. Pulse Width Modulated (PWM) signal as follows: A 1 second application of 115 VAC corresponds to the Control Center operator programmed **CHILLED LIQUID TEMP** setpoint . . . An 11 second application of 115 VAC corresponds to the maximum allowable remote reset value, 10°F or 20°F (Refer to description of **REMOTE RESET TEMP RANGE**). All settings between 1 sec. and 11 sec. are linearly scaled. Refer to Fig. 12. Input will only be accepted if Control Center is in **REMOTE** mode. Calculate the setpoint as follows:

$$^{\circ}\text{F Offset} = \frac{(\text{Pulse Width} - 1) (\text{Remote Reset Temp Range})}{10}$$

$$\text{Setpoint} = \text{Keypad Entered Setpoint} + ^{\circ}\text{F Offset}$$

TB2-1—Connected to 115 VAC on Digital Input Board. Source voltage for remote LCWT setpoint (PWM signal) and remote current limit setpoint (PWM signal). Refer to Fig. 12.

TB2-20—Remote current limit setpoint from external Energy Management System (EMS). Signal is a 1-11 sec. Pulse Width Modulated (PWM) signal as follows: A 1 second application of 115 VAC corresponds to a setting of 100% FLA . . . an 11 second application of 115 VAC corresponds to a setting of 40% FLA. All settings between 1 sec. and 11 sec. are linearly scaled. Input will only be accepted when Control Center is in **REMOTE** mode. Refer to Fig. 12. Calculate the setpoint as follows:

$$\text{Setpoint} = 100\% [(\text{Pulsewidth} - 1) 6\%]$$

TB2-1—Connected to 115 VAC on Digital Input Board. Source voltage for chilled water pump interlock/flow switch inputs. Refer to Fig. 13.

TB2-12 — Chilled water pump interlock or flow switch contacts input. 115 VAC when interlock or water flow is established. This condition is a prerequisite to running the compressor. Refer to Fig. 13.

TB2-1 —Connected to 115 VAC on digital input board. Source voltage for Local/Remote Cycling Device Input and multi-unit sequence input. Refer to Fig. 14 (Details A & B).

TB2-9—Multi-unit sequence kit input. 115 VAC when sequence kit enables the compressor to run. If no multi-unit sequence kit is provided, this input must be jumpered as shown in Fig. 14, Detail B. "**COMPRESSOR**" switch must be in **RUN** ition to enable input. Refer to Fig. 14 (Details A & B).

TB2-13—Remote/local cycling device input. 115 VAC when remote device enables the compressor to run. If no cycling device is provided, this input must be jumpered as shown. Compressor switch must be in "Run" position. to enable input. Refer to Fig. 14 (Details A & B).

DIGITAL INPUT BOARD – OUTPUTS

All outputs are +5VDC in the active state. In other words, a 115 VDC input signal causes a +5VDC output level on the corresponding board output. A 0VAC input causes a 0VDC output. All outputs interface to the micro board via ribbon cable.

- J1-1 – Vane Motor Switch
- 2 – HP Safety,
- 3|–|Not Used
- 4|–|Not Used
- 5 – Not Used
- 6 – Not Used
- 7 – Motor Controller
- 8 – Stop (Local)
- 9 – Start (Local)
- 10 – Not Used
- 11 – Not Used
- 12 – Not Used
- 13 – 5V Return
- 14 – +5V Regulated
- 15 – Remote Start
- 16 – Remote Stop
- 17 – Remote LCWT Setpoint
- 18 – Remote Current Limit Setpoint
- 19 – Flow Switch
- 20 – Local/Remote Cycling Device
- 21 – Multi-Unit Sequence
- 22 – Not Used
- 23 – Not Used
- 24 – Aux. Safety Shutdown
- 25 – LEP (Brine Units Only)
- 26 – Not Used

SECTION 3B RELAY OUTPUT BOARD

(Ref. 15 & 16)

The Relay Output Board allows the Micro Board to be interfaced to 115 VAC output signals. Ten board-mounted relays are driven by the micro board. One side of each relay coil is connected to +12VDC regulated power. The other side of the coil is connected to the input connector J1. The Micro Board is connected to this connector and it drives the appropriate pin to ground potential when it wants to energize a selected relay. The contacts (N.O.) of each relay are interfaced, via Terminal blocks TB3 and TB4, to various external relays and solenoids.

Terminal block TB3 is provided for interfacing the system start relay, the system stop relay, selected system safeties, system solenoids and the vane motor. The water temperature control circuits that control the vane motor are located on the micro board. These circuits control two triacs located on the relay output board; one to open the vanes and one to close the vanes. The triacs are then interfaced to the open and close windings of the vane motor.

Terminal block TB4 is provided for field interface of system status contact closures & chilled water pump contacts.

RELAY OUTPUT BOARD – INPUTS

All inputs are logic low in the active state. A logic low input to this board causes the output relay to energize. A +12VDC input causes the output relay to de-energize. All inputs interface from the micro board.

- J1-1 - Cycling Shutdown
- J1-2 - Safety Shutdown
- J1-3 - Chilled Water Pump
- J1-4 - Remote Mode Ready to Start
- J1-5 - Motor Starter—Start
- J1-6 - High Speed Thrust Solenoid
- J1-7 - Oil Return Solenoid
- J1-8 - Motor Starter - Stop
- J1-9 - Vent Line & Liquid Line Solenoid
- J1-10 - Oil Pump
- J1-11 - PRV Close*
- J1-12 - PRV Close*
- J1-13 - PRV Open**

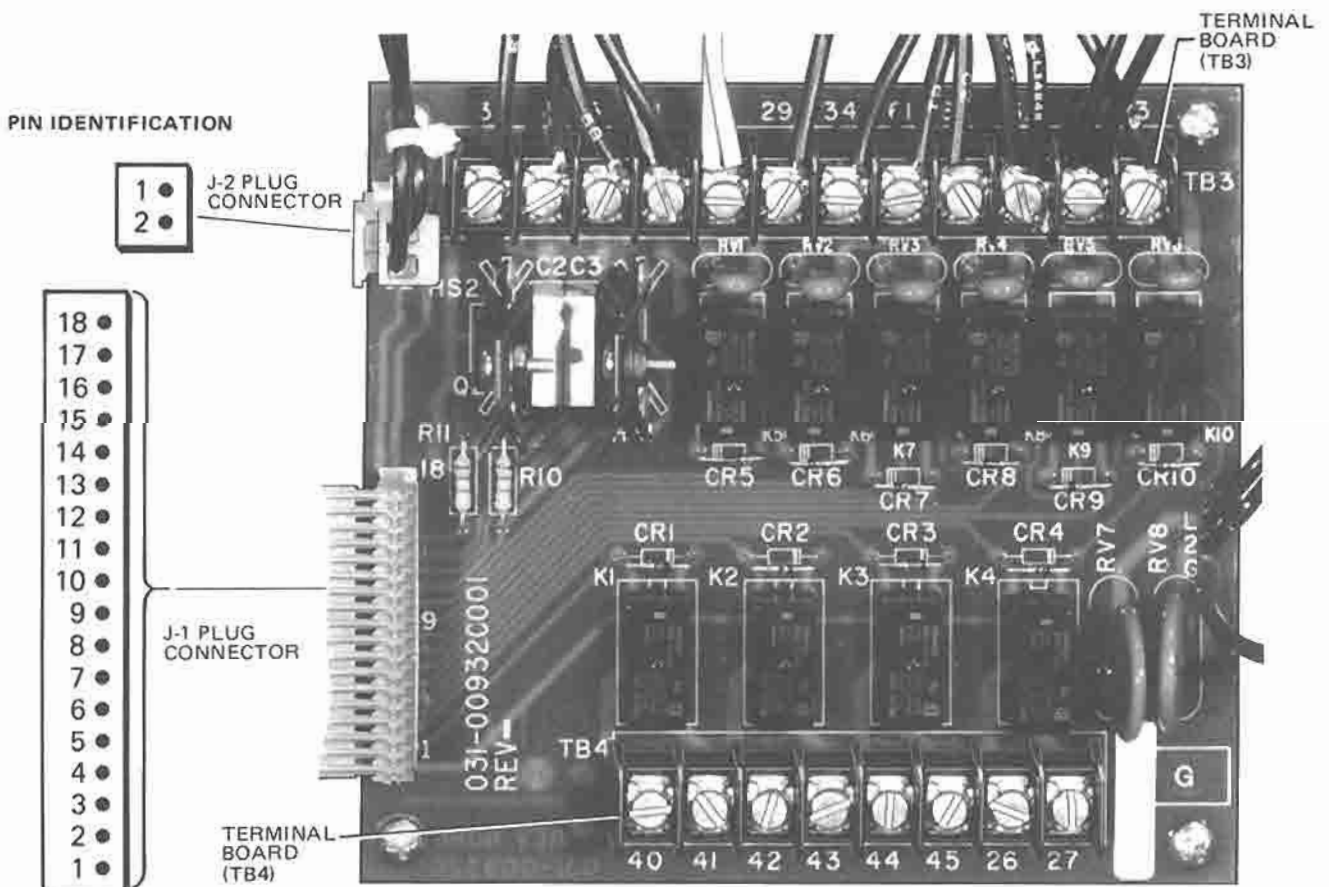

24680

FIG. 15 – RELAY OUTPUT BOARD

- J1-14 - PRV Open**
- J1-15 - Not Used
- J1-16 - Not Used
- J1-17 - +12VDC Return
- J1-18 - +12VDC Return
- J2-1 - +12VDC Return
- J2-2 - +12VDC

- TB3-1 - 115VAC
- TB3-2 - 115VAC Neutral

*PRV Close - 0VAC as measured from J1-11 to J1-12 when Micro Board is commanding the vanes to close. Approx. 24VAC—28VAC when vanes are holding or opening.

**PRV Open - 0VAC as measured from J1-13 to J1-14 when Micro Board is commanding the vanes to open. Approx. 24VAC—28VAC when vanes are holding or closing.

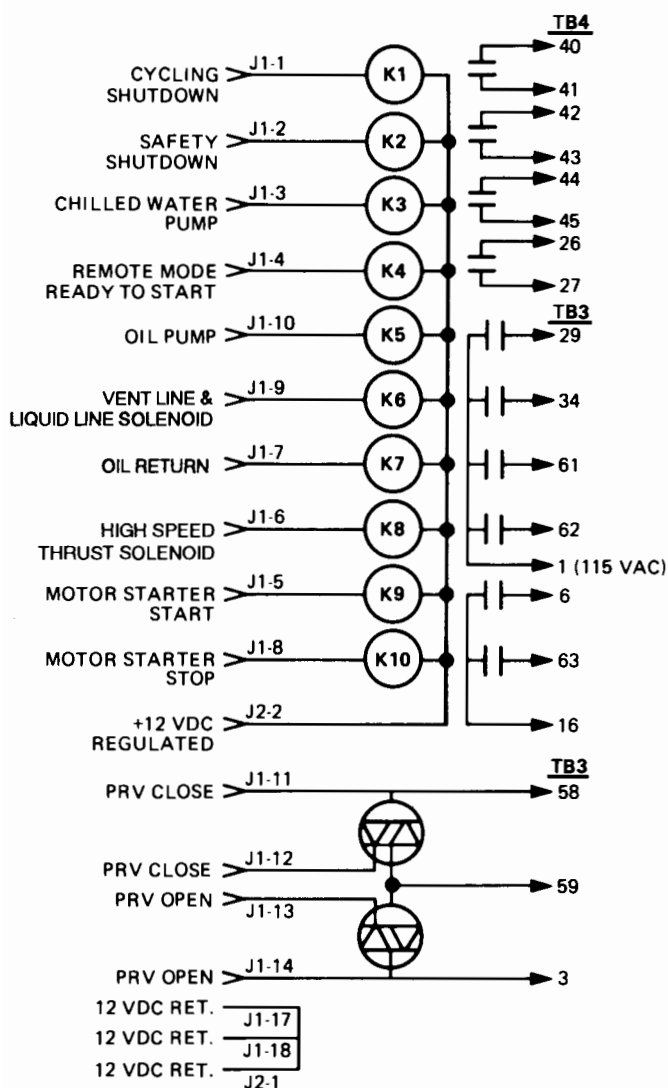

FIG. 16 - RELAY OUTPUT BOARD SIMPLIFIED SCHEMATIC DIAGRAM

RELAY OUTPUT BOARD - OUTPUTS

TB3-59 - PRV Common

TB3-3 - PRV Motor winding. 0VAC measured to TB3-59 when vanes are opening. Approx. 24VAC—28VAC when vanes are holding or closing.

TB3-58 - PRV Motor close winding. 0VAC measured to TB3-59 when vanes are closing. Approx. 24VAC—28VAC when vanes are holding or opening.

TB3-29 - Oil pump starter contacts. 115VAC when Micro Board is commanding the oil pump to run.

TB3-34 - Vent line solenoid and liquid line solenoid valve contacts. 115 VAC when Micro Board is commanding the solenoid valves to open.

TB3-6 - Motor starter contacts (Ref. Fig. 17). Part of 1R (start relay) anti-chatter circuit. After the 30 second pre-lube (**START SEQUENCE INITIATED**) the Micro Board energizes K9 and K10 coincident with the Micro Board going into "RUN" mode (**SYSTEM RUN-LEAVING TEMP CONTROL**). 1R is energized thru K9 contacts causing 1R-4 contacts to close creating a holding circuit thru 1R-4 and K10 contacts. After 200 milliseconds, the Micro Board de-energizes K9. 1R remains energized thru 1R-4 and K10 contacts. If 1R fails to energize or if it de-energizes at any time while the Micro Board is in **SYSTEM RUN-LEAVING TEMP CONTROL**, 1R cannot again energize until K9 is again energized at completion of **START SEQUENCE INITIATED** (the next chiller start). When 1R de-energizes while **SYSTEM RUN-LEAVING TEMP CONTROL** is displayed the Micro Board senses a loss of motor current (for 25 continuous seconds) and shuts down the chiller and displays **AC UNDER-VOLTAGE-AUTOSTART**. Refer to explanation of this message in Operating Manual Form 160.49-O1.

TB3-16 - Motor controller input. 115VAC when motor controller device is satisfied. Otherwise, 0VAC.

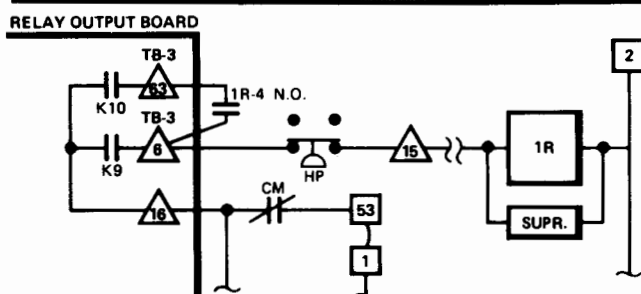

FIG. 17 - RELAY OUTPUT BOARD

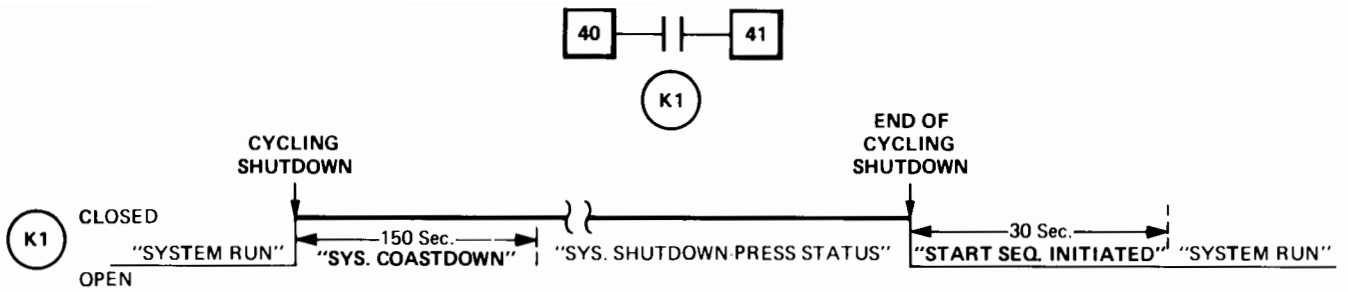

FIG. 18 – STATUS CONTACTS - CYCLING SHUTDOWN

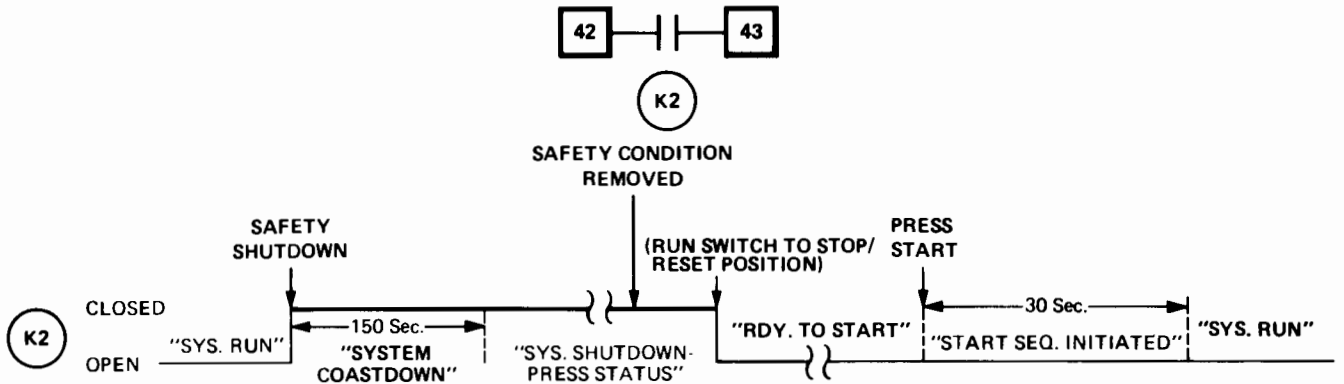

FIG. 19 – STATUS CONTACTS - SAFETY SHUTDOWN

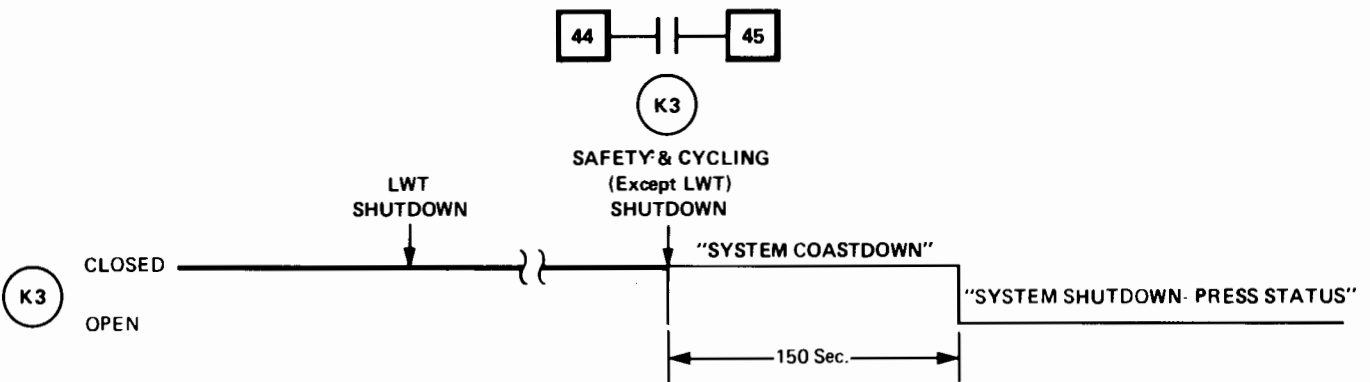

FIG. 20 – CHILLED WATER PUMP CONTACTS - CYCLING AND SAFETY SHUTDOWNS PROGRAM JUMPER (J54) INSTALLED ON MICRO BOARD

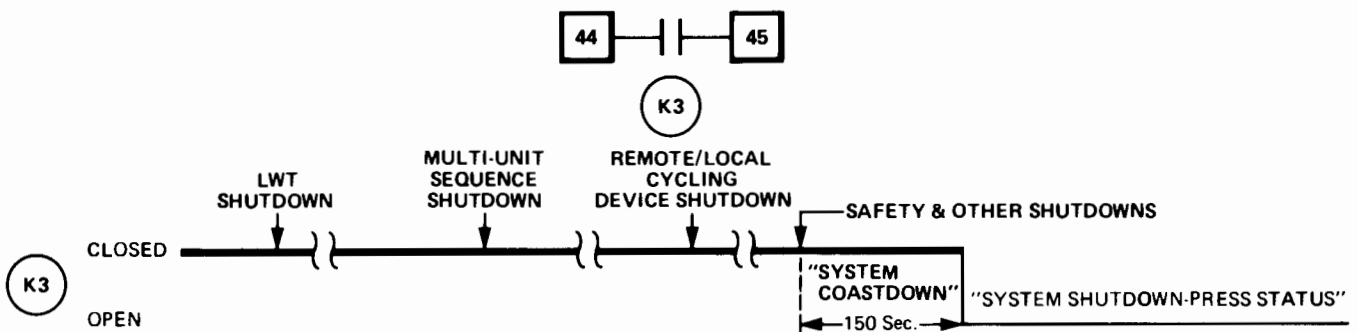
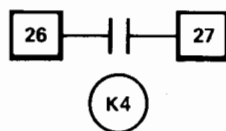
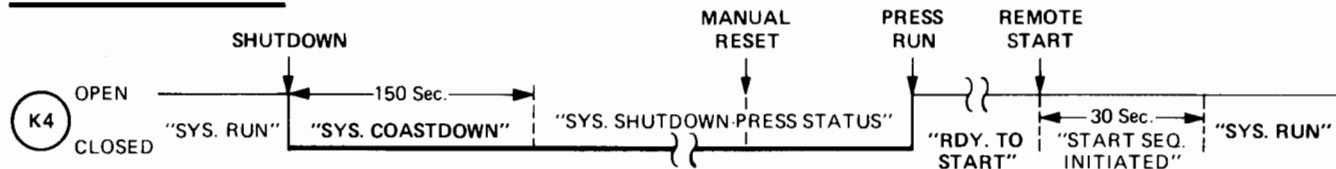

FIG. 21 – CHILLED WATER PUMP CONTACTS - CYCLING AND SAFETY SHUTDOWNS PROGRAM JUMPER (J54) REMOVED ON MICRO BOARD

**CYCLING SHUTDOWN****SAFETY SHUTDOWN****FIG. 22 — REMOTE MODE READY TO START CONTACTS**

TB3-61 - Oil return solenoid valve contacts. 115 VAC when Micro Board is commanding the oil return solenoid valve to energize (OPEN). Otherwise, 0 VAC.

TB3-62 — High speed thrust bearing solenoid valve contacts. 115VAC when Micro Board is commanding the valve to open. This occurs 15 seconds after the compressor motor is started. 0VAC when the Micro Board de-energizes (closes) the valve. This occurs coincident with removing the start signal from the compressor motor starter.

TB3-63 — Motor starter stop contacts (Ref. Fig. 17). Part of 1R (start relay) anti-chatter circuit. 115 VAC when Micro Board is commanding the compressor motor to run and the motor controller contacts (CM) are closed. Refer to explanation of TB3-6.

TB4-40/41 — Cycling shutdown contacts. Dry closure N.O. contacts (rated for 115VAC; 2 AMPS) available for remote status indications. Contacts will close whenever chiller is shutdown on a "Cycling" shutdown. A "Cycling" shutdown is that which does not require a local manual reset at the Control Center to restart the compressor; such as local/remote cycling device, low water temp, motor controller or multi-unit sequence kit. When shutdown control is satisfied, the system will restart automatically. The contacts open upon "Start Sequence Initiated" or when the "COMPRESSOR" switch is placed in "STOP/RESET" position. Refer to Fig. 19.

TB4-42/43 - Safety shutdown contacts. Dry closure N.O. contacts (rated for 115VAC; 2 AMPS) available for remote status indications. Contacts will close whenever chiller is shut down on a "safety" shutdown. A "safety" shutdown is that which requires a local manual reset at Control Center to

restart system; such as power failure (manual restart option), Motor phase current unbalance (Solid State Starter only), starter malfunction detection, LEP, HOT, HDT, LOP, HOP, or HP. The contacts will open when the "COMPRESSOR" switch is placed in "STOP/RESET" position and the condition that caused the safety no longer exists. The system must be manually restarted. Refer to Fig. 19.

TB4-44/45 — Chilled water pump contacts. Dry closure N.O. contacts (rated for 115VAC, 2 AMPS) that can be used to automatically start and stop the chilled water pump under microprocessor control. An anti-chatter circuit on the Micro Board prevents this output from energizing the chilled water pump at a rate greater than once every 10 seconds. A program jumper ("LWT PMP"-J54) located on the Micro Board determines the operation of these contacts as follows:

JUMPER INSTALLED (as shipped from factory) Fig. 20.

The contacts will close (starting the chilled water pump) when a chiller start sequence is initiated. Any shutdown command, except LWT (Low Water Temp), will cause the contacts to open (stopping the chilled water pump) at the completion of "System Coastdown". When the chiller shuts down on LWT the contacts remain closed, causing the chilled water pump to continue to run.

JUMPER REMOVED (Fig. 21)

The contacts operate the same as with the jumper installed except that in addition to LWT shutdowns keeping the pump running, **Multi-Unit Sequence** (Digital In-

put Board TB2-1,9) and **Remote/Local Cycling** (Digital Input Board TB2-1,13) shutdowns also allow the pump to continue to run after **SYSTEM COASTDOWN**.

TB4-26/27 – Remote mode ready to start contacts. Dry closure N.O. contact (115VAC, 2A). Available for remote status indication to an Energy Management System (EMS). The contacts will be closed if the Control

Center is in **REMOTE** mode and the **COMPRESSOR** switch is in the **RUN** position and all safeties, cycling devices and 30 min. anti-recycle timer are satisfied. The contacts will open coincident with any safety or cycling device becoming unsatisfied or if the Control Center is put in **LOCAL** mode, or if the “**COMPRESSOR**” switch is moved to the STOP position. Refer to Fig. 22.

SECTION 3C POWER SUPPLY BOARD

(Ref. Fig. 23 & 24)

This board provides the necessary operating voltages for all the PC boards in the MicroComputer Control Center. A step-down transformer (1T) (external to the power supply board) provides 24VAC to a bridge rectifier. The unregulated output (≈ 30 VDC) is applied to the a.) Liquid Cooled Solid State Starter Logic Board if is applied, or b.) CM-2 current module if Electro-Mechanical Starter is applied. The Solid State Starter logic board and CM-2 module have their own on-board power supplies that supply the required voltages for these boards.

Two switching regulators supply +12VDC and +10VDC to the Relay Output Board and Micro Board respectively. The 10VDC output is further regulated to +5VDC

for use by the vacuum fluorescent display. Finally, a voltage regulator supplies +24VDC to the optional card file for use by the remote LCWT setpoint card and remote current limit setpoint card.

A **Display Reset Circuit** outputs a reset signal to the vacuum fluorescent display during low voltage situations. This prevents “latch-up” conditions in the display, whenever the +5VDC regulated output (J2-4) to the display is equal-to or less-than 4.7VDC, the **RESET** output (J6-2) transitions from +5VDC to a logic low condition (less-than 1VDC). This causes the display to blank for the duration of the condition.

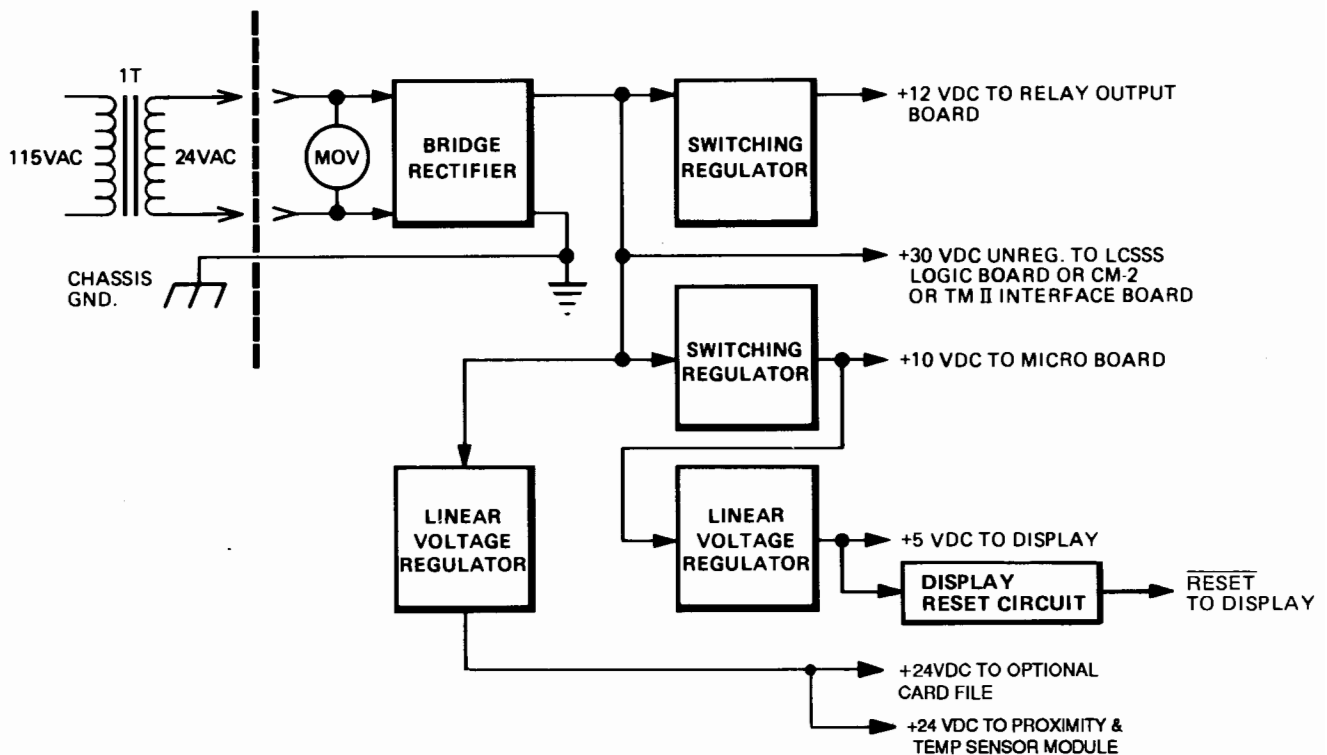
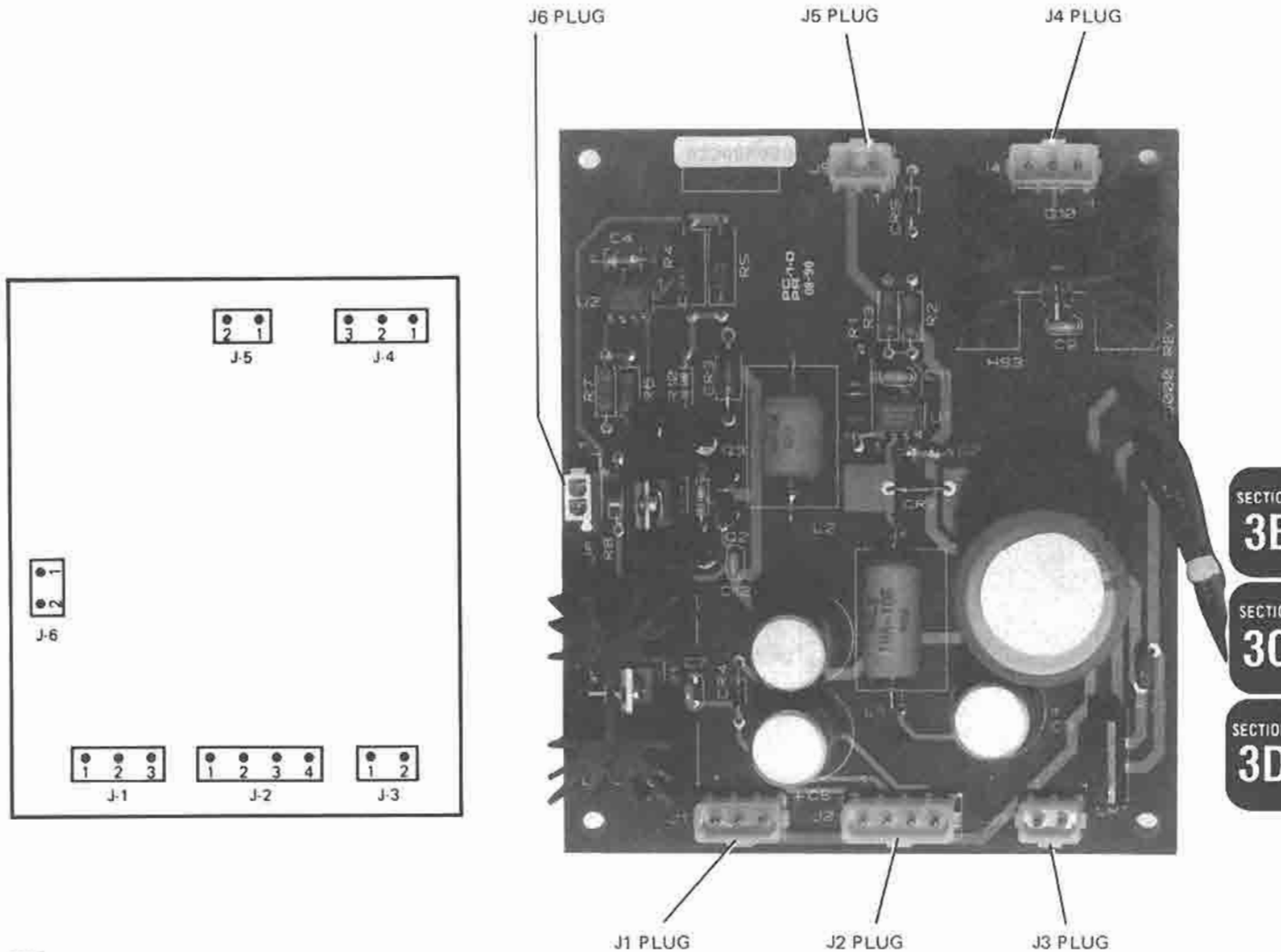

FIG. 23 – POWER SUPPLY BOARD DIAGRAM



25607

FIG. 24 — POWER SUPPLY BOARD

SECTION 3D MICRO BOARD

(Ref. Fig. 25 & 26)

The Micro Board contains a microprocessor. An external RAM is provided for scratchpad memory and the operating program is stored in an external EPROM. Operator entered system setpoints are stored in battery-backed RAM available in the real-time clock (RTC). The RTC also stores and updates the time-of-day, day-of-week, and calendar date.

System analog parameters (Pressures, Temperatures, Motor Current) are input to the multiplexer (MUX). Under program control these parameters are transmitted serially to the analog to digital converter where they are converted to digital words. The Micro Board compares these values to stored safety thresholds (EPROM) and initiates a chiller shutdown if thresholds are exceeded. These parameters are stored for: a.) subsequent viewing on the display if requested by the operator thru keypad operation; b.) Data transmission thru RS-232

or RS-485 serial ports. The Micro Board also uses these parameters for system control. Specifically, leaving chilled water temp control via prerotation vane movement, current limit control, high and low pressure limit control.

An undervoltage detection circuit monitors the +5VDC unregulated (approx. 10VDC) input from the power supply board. This voltage is compared to a reference voltage. When the input voltage decreases to the reference voltage threshold, the undervoltage detector output transition is read by the Micro Board via the PIA No. 1 and the Micro Board initiates a chiller shutdown. If the **AUTO-R (J50)** program jumper on the Micro Board is installed (Auto-Restart After Power Failure) and the keypad **COMPRESSOR** switch is in the **RUN** position, the Micro Board will initiate a chiller start (**START SEQUENCE INITIATED** is displayed) when power is

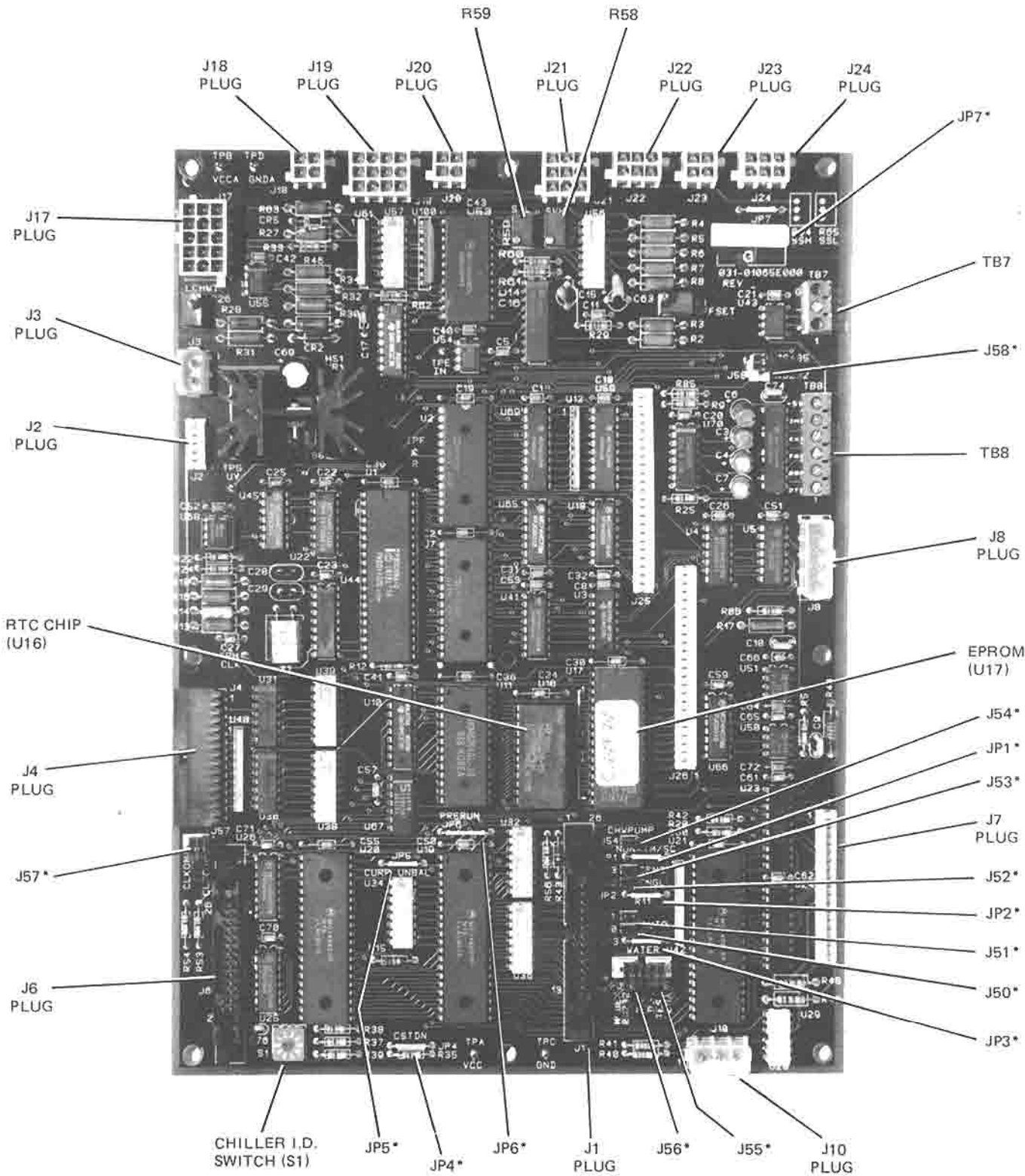

*PROGRAM JUMPER

25608
 FIG. 25 – MICRO BOARD AND PLUG IDENTIFICATION

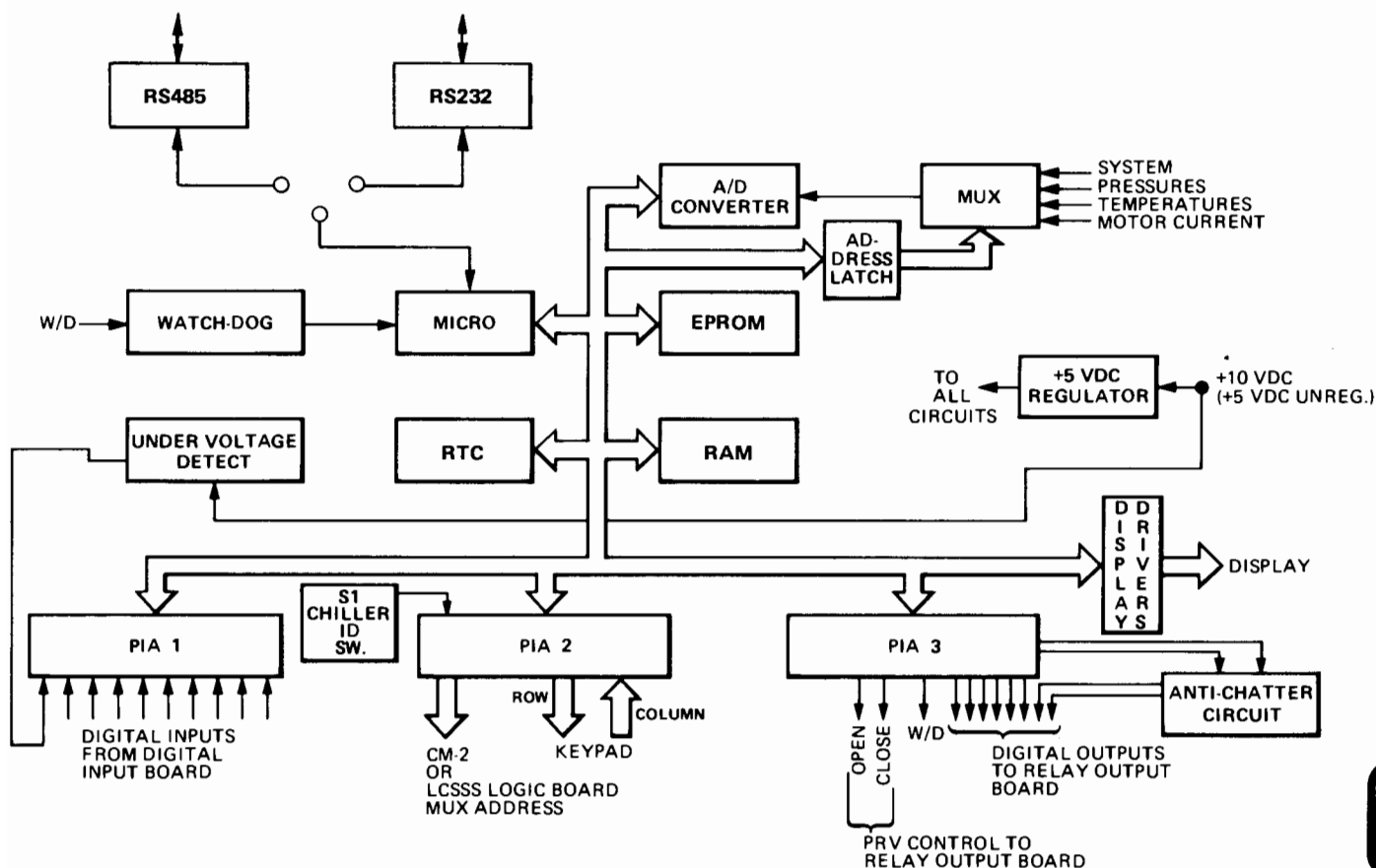

FIG. 26 – MICRO BOARD BLOCK DIAGRAM

restored. If the **AUTO-R (J50)** program jumper is removed (Manual Restart After Power Failure), "SYSTEM SHUTDOWN-PRESS STATUS" is displayed when power is restored. "Mon 10 00 AM - POWER FAILURE" is displayed when the operator presses the keypad **STATUS** key. The Micro Board will prevent a chiller restart until the operator moves the **COMPRESSOR** switch to the **STOP-RESET** position and then to the **START** position.

A watchdog circuit ensures that the complete program is executed every program cycle. This prevents the program from looping endlessly in a subroutine with the result that critical chiller parameters could be overlooked. Each program cycle ($\approx 100\text{MS}$) the Micro Board outputs a pulse to the watchdog circuit via the parallel interface adapter (PIA). This pulse starts a 2 second timer in the watchdog circuit. If another pulse is not received by the watchdog circuit before 2 seconds have elapsed, the watchdog circuit will output a reset pulse to the Micro Board. The Micro Board shuts down the chiller, re-initializes the program and displays "MON 10 00 AM PROGRAM INITIATED RESET". The Micro Board will automatically restart the chiller.

Serial data interfacing to external equipment is provided through an RS-232 port (TB8) or an RS-485 port (TB7). Both ports cannot be connected to external devices at

the same time. The position of program jumper J58 determines which port is enabled.

The RS-232 port can be connected to a local printer (Ref. Form 160.49-N2) and/or a modem that is used for "YORK Guardian Service/Remote Chiller Communications". Program jumper J56 must be in the **MODEM** position when this port is used.

The RS-485 port can be connected to the "YORK FAX-4500" facility automation system. Program jumper J56 must be in the **EMS** position when this port is used.

The Real-Time Clock (RTC) circuit stores and updates the time-of-day, day-of-week and calendar date. Anytime the chiller shuts down on a safety or cycling shutdown, the "Day" and "Time" of shutdown is displayed along with the cause of shutdown. This "Time" information is also used to determine correct chiller start and stop times when the programmable internal time clock is used to automatically start and stop the chiller. The RTC chip contains a non-replacable battery. This battery powers the RTC RAM in the event of an AC power failure. All of the keypad programmable setpoints are stored in the RTC RAM. Therefore, the setpoints will be saved during a power failure. The life of this battery is 5-10 yrs. During each program cycle, the Micro Board monitors the

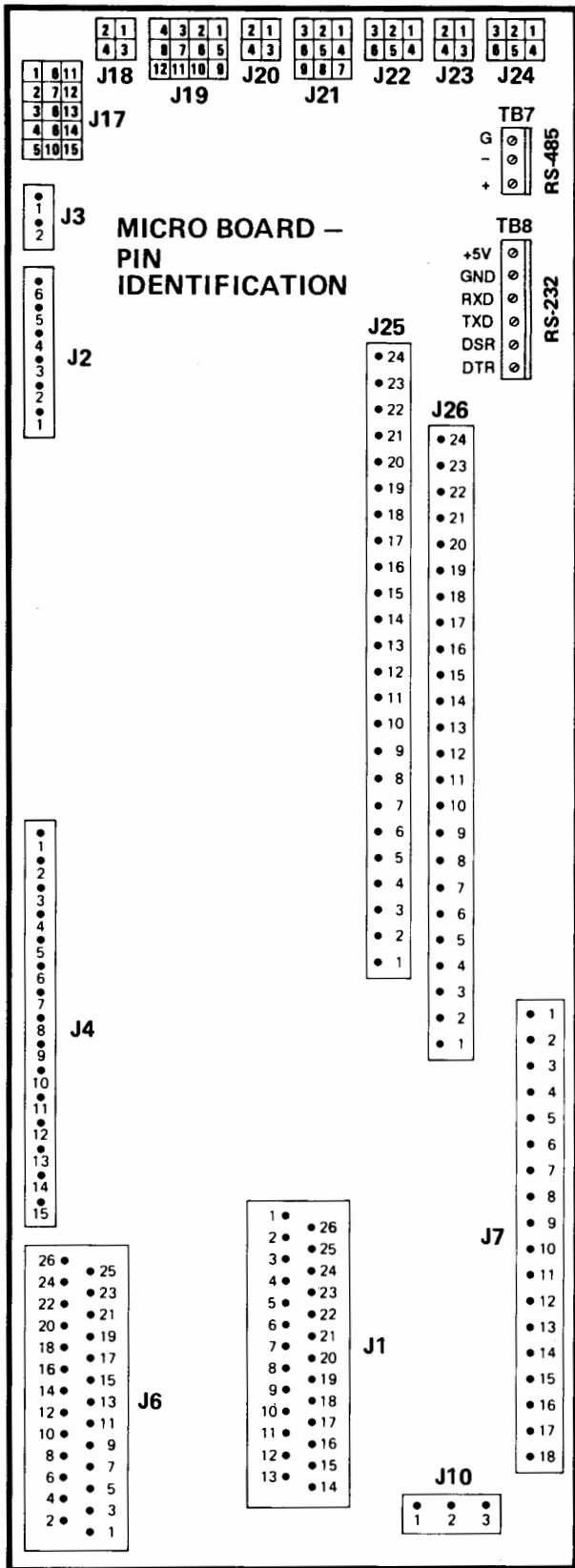

NOTE: USE AMP REMOVAL TOOL 724668-2 WHEN REMOVING PINS FORM J17-J24

FIG. 27 - MICRO BOARD PLUG PIN IDENTIFICATION

condition of the battery. If a low battery condition is detected, **REPLACE RTC U16-REPROGRAM SETPOINTS** is displayed on the keypad display. If this message appears the RTC Chip (U16) must be replaced. Refer to instructions in operating manual Form 160.49-O1. This RTC chip (YORK Part Number 031-00955-000) is available from the YORK Parts Distribution Centers. To conserve battery life over winter shut-downs, J57 Program Jumper must be positioned to the **CLOCK OFF** position. Refer to Fig. 31 for procedure. Also, the service technician must turn-on the clock during chiller commissioning.

The Parallel Interface Adapters (PIA) allow the Micro Board to interface to digital inputs and outputs. Each PIA formats the digital inputs, or outputs into 8 bit words. PIA No. 1 receives the digital (On/Off) inputs from the digital input board. These are 115VAC system inputs that have been converted to +5VDC/0VDC digital inputs by the digital input board. In each program cycle, the digital inputs are read by the Micro Board. The Micro Board, under program control, acts accordingly on the digital inputs. For example, if the High Pressure (HP) input transitions from 0VDC to +5VDC, the Micro Board initiates a chiller shutdown and displays the appropriate message.

PIA No. 2 sends a 3-bit address to the CM-2 Current Module (Electro-Mechanical Starter Application) (Ref. Fig. 28) or LCSSS Logic Board (Ref. Fig. 29) (Solid State Starter Applications). This address is applied to a multiplexer. The multiplexer outputs analog data that is applied to the Micro Board multiplexer. The addresses and data are as follows:

CM-2 CURRENT MODULE

ADDRESS	DATA
000	Ground (EM Starter Identification)
001	None (GND.)
010	None (GND.)
011	None (GND.)
100	None (GND.)
101	None (GND.)
110	None (GND.)
111	Motor Current-Highest Phase

LCSSS LOGIC BOARD

ADDRESS	DATA
000	Starter Model-7L, 14L, 26L, 33L (Ammeter Scale) and Voltmeter full scale
001	Current limit commands (<1.2VDC = ≥ 104% FLA, 1.21-3.45 VDC = ≥ 100% FLA, ≥ 3.46 VDC = < 98%)

010	∅C AC Line Voltage
011	∅B AC Line Voltage
100	∅A AC Line Voltage
101	∅A Motor Current
110	∅B Motor Current
111	∅C Motor Current

On Electro-Mechanical Starter Applications (CM-2) (Ref. Fig. 28) the Micro Board uses the motor current (highest phase) value to perform "Current Limit" function. When the motor current is equal to 100% FLA the Micro Board will not allow the vanes to open any further until current decreases to 98%. When the motor current is equal to 104% FLA the Micro Board will begin closing the vanes until the current decreases to 102% FLA.

This motor current value is also displayed, by pressing the "% Current Limit Key" on the keypad. If the operator has programmed a "Pull-down Demand Limit" or "% Current Limit" function on the keypad, the Micro Board will control the vanes to limit the motor current to the specified value. The Micro Board also checks to assure that motor current is present when the Control Center is in **RUN** mode ("System Run—leaving Temp Control" displayed). If no motor current is present the Micro Board initiates a chiller shutdown. (Refer to "AC Undervoltage" shutdown description in operating instruction Form 160.49-O1).

On Liquid Cooled Solid State Starter (LCSSS) applications (Ref Fig. 29), the first data the Micro Board reads from the LCSSS logic board is the starter model (size) and line voltage application. The LCSSS can be ordered in four sizes . . . 7L, 14L, 26L, 33L. Each size has a different maximum starting current and full load amp capability. Also, within these different models there are different line voltage models. Since the Micro Board displays 3∅ motor current and 3∅ line voltage, the starter size and voltmeter full scale value must be available to the Micro Board in order to calculate the correct motor current and line voltage display. This data is supplied as an analog voltage. The value is determined by the LCSSS Logic Board model detector circuit and the position of the 300V/600V jumper. The position of this jumper determines the "Voltmeter" full scale display capability.

The next data the Micro Board reads is the current limit commands from the LCSSS Logic Board. This is an analog voltage that tells the Micro Board when to initiate **CURRENT LIMIT** control. If the operator has entered a current limit setpoint at the keypad of less than 100% FLA, **CURRENT LIMIT** control is totally under Micro Board (Software) control. Specifically, the vanes are prevented from opening any further at 100% FLA (they will be allowed to open when current falls to 98% FLA.); at 104% FLA the vanes are driven closed until the motor current decreases to 102% FLA. However, if the operator entered setpoint is 100% FLA, the LCSSS Logic Board

tells the Micro Board when to initiate current limit control. To illustrate, when the motor current rises to 100%, as determined by the calibration of the LCSSS Logic Board **OVERLOAD** pot, the LCSSS Logic Board sends a command (1.21-3.45VDC) to the Micro Board. The Micro Board then prevents the vanes from further opening until the Logic Board detects motor current has decreased to 98% FLA, at which time another command (> 3.46VDC) is sent to the Micro Board and the Micro Board allows the vanes to open. If the motor current had increased to 104% FLA, the Logic Board would send another command (< 1.20VDC) which would cause the Micro Board to drive the vanes closed until the logic board detects the motor current has decreased to 102% FLA. The current limit command would then transition to 1.21-3.45VDC. This causes the Micro Board to stop closing the vanes.

The next data read from the LCSSS Logic Board is the 3∅ AC Power Line Voltage. This is 3 individual analog voltages. The Micro Board converts those analog voltages to AC line voltage values and displays them upon operator request. Also, they are checked to assure each phase meets the minimum required compressor motor starting and running voltage. If the requirements are not met, the Micro Board initiates a chiller shutdown and displays **"MON XX XX AM LOW LINE VOLTAGE"** (Refer to explanation of this message in operating instruction, Form 160.49-O1). The service technician can disable this line voltage check through setpoint programming at the keypad. (Refer to "System Setpoints" in operating instruction Form 160.49-O1).

The next data read is the 3∅ motor current. This is 3 individual analog voltages. The Micro Board converts these analog voltages to motor current values and displays them upon operator request. If the **CURR UNBAL** program jumper is installed on the Micro Board, the motor current is checked to assure balanced motor current in the 3 phases. If the balance requirement is not satisfied, the Micro Board initiates a chiller shutdown and displays **"MON XX XX AM — PHASE CURRENT UNBALANCE"** (Refer to explanation of this message in Operating Instruction Form 160.49-O1). If the **CURR UNBAL** program jumper is removed, the balance of the 3∅ motor current is not checked and no shutdown is initiated. At current limit setpoints of less than 100%, the Micro Board executes current limit when the highest phase current equals the current limit setpoint. For example, if the FLA of a chiller is 200 AMPS and the operator has programmed a current limit setpoint of 50%, the Micro Board will inhibit the vanes from further opening when the current in the highest phase equals 100 AMPS (100%). When the current in the highest phase equals 104 A (104%) the Micro Board closes the vanes until the current in the highest phase decreases to 102%.

PIA No. 2 interfaces to the front panel keypad to determine which key the operator is pressing (Ref. Fig. 30).

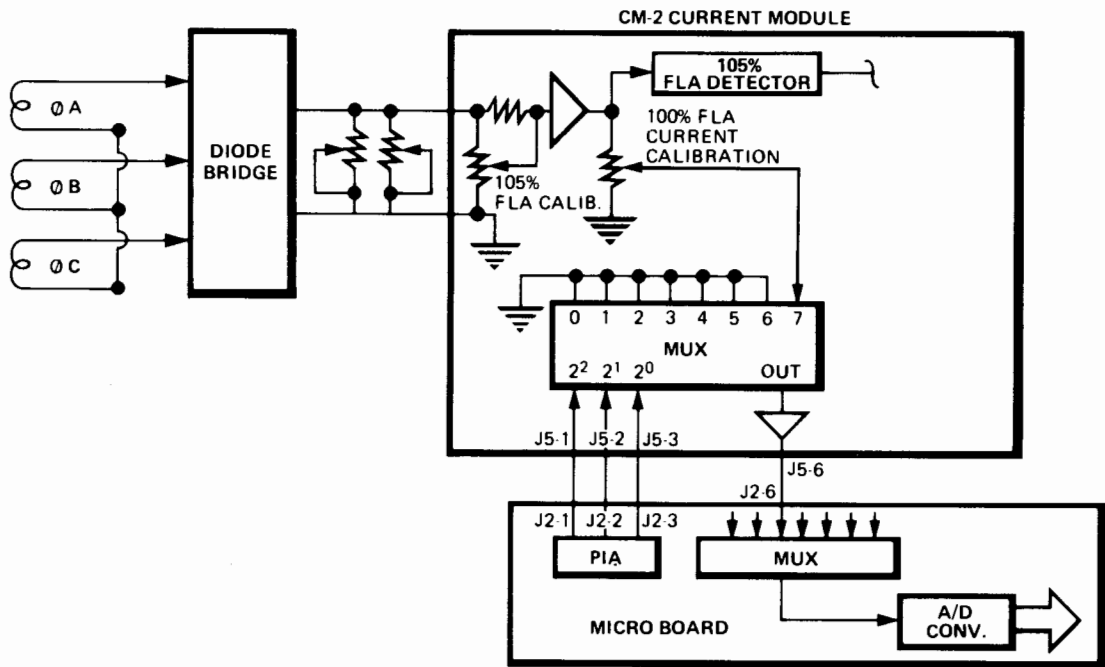

FIG. 28 – CM-2 CURRENT MODULE INTERFACE TO MICRO BOARD
(USE WITH ELECTRO-MECHANICAL STARTING)

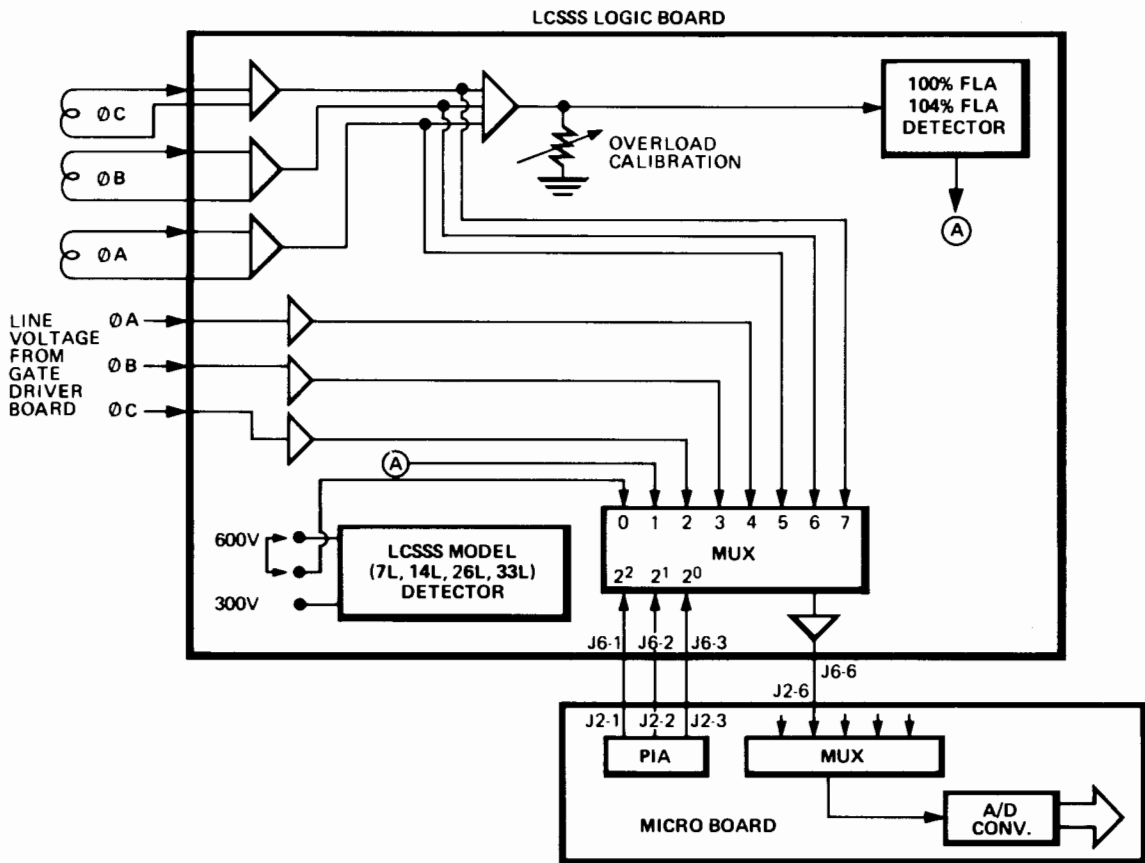

FIG. 29 – LCSSS LOGIC BOARD INTERFACE TO MICRO BOARD

The keypad is a two-layer matrix of conductors arranged in a configuration of rows and columns. When a key is pressed, the conductor in that column makes contact with the conductor in that row. There are 6 PIA outputs to

the keypad rows. The rows are designated 4, 8, 10, 20, 40, 80. There are 8 PIA inputs from the keypad columns. The columns are designated 1, 2, 4, 8, 10, 20, 40, 80. At regular intervals the Micro Board reads the keypad keys

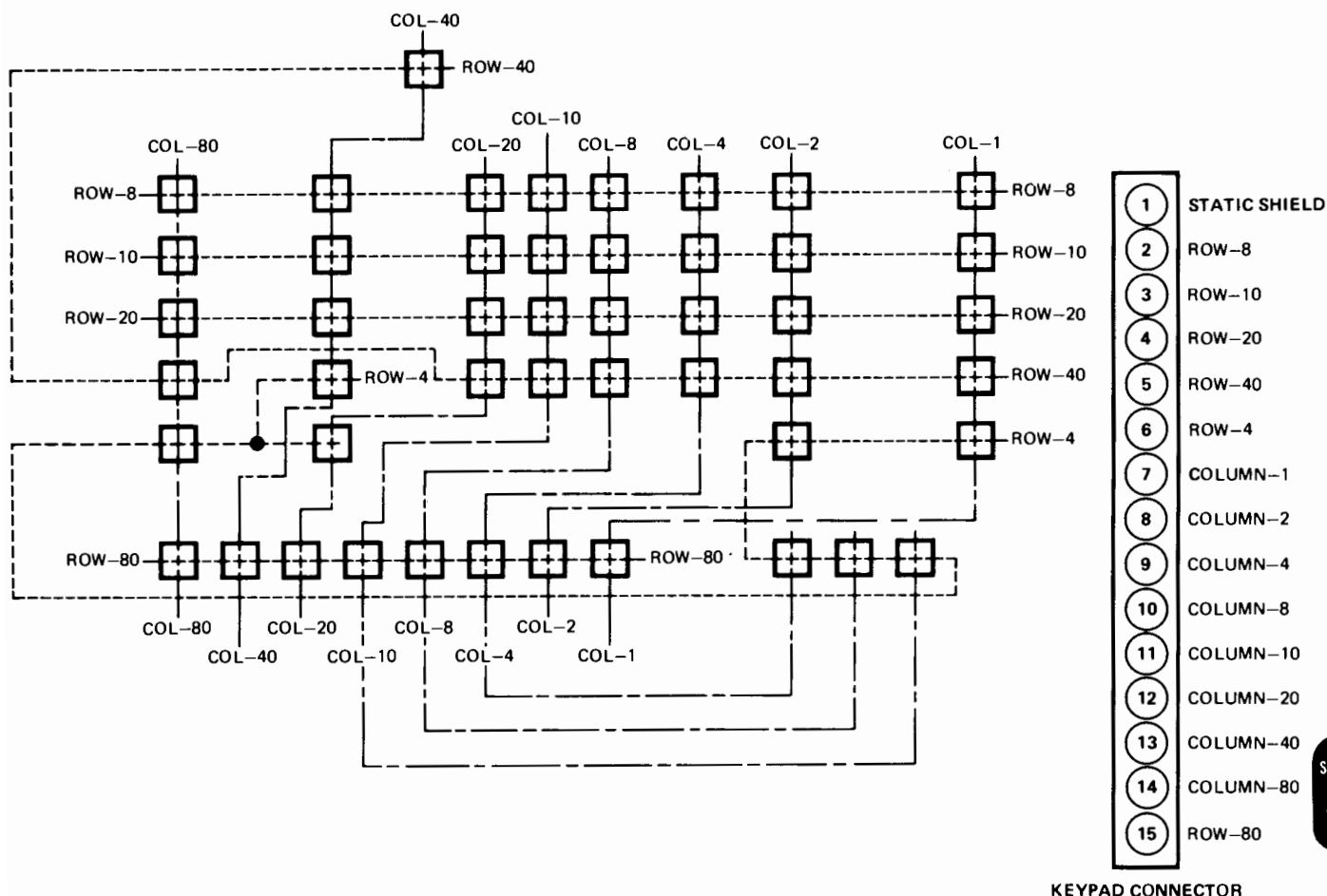

FIG. 30 – KEYPAD CONNECTION MATRIX

by sequentially driving the PIA outputs to the rows to logic low and reading the resultant voltage at the column input to the PIA. For example, when row 8 is driven to logic low, if no keys are accessed in that row, all column inputs to the PIA will be +5VDC. However, if any key is pressed in row 8, the appropriate column input to the PIA would be at logic low potential.

On Electro-Mechanical Starter and Liquid Cooled Solid State Starter (LCSSS) applications PIA No. 3 drives the pre-rotation vanes via triacs located on the relay output board. The Micro Board compares the leaving chilled water temperature (as determined by the LCWT thermistor) to the programmed “**CHILLED LIQUID TEMP**” setpoint and modulates the vanes to achieve the desired leaving chilled water temperature. Similarly, the Micro Board modulates the vanes to prevent the compressor motor current from exceeding the programmed “**% CURRENT LIMIT**” setpoint. There are two PIA outputs; one feeds the “Open” triac and one feeds the “Close” triac on the relay output board. When the Micro Board commands the vanes to open, the PIA output turns on the “Open” triac. When the Micro Board commands the vanes to close, the PIA output turns on the “Close” triac. In each case, the turn-on of the triac causes the open or close winding of the vane motor to be shorted to the

vane motor common terminal causing the vanes to open or close respectively.

The PIA No. 3 interfaces to the Relay Output Board (J1) to control DC relays located on that board. There are three system status relays that provide status to external devices such as energy management systems. Another relay can control the chilled water pump automatically under program control. Two other relays control the start and stop signal to the compressor motor starter. The remainder of the relays control the oil pump starter and vent line solenoid. (Refer to explanation of the relay functions under “Relay Output Board” section of this instruction page 12.). Under program control, the Micro Board energizes the relays by driving the PIA output to ground (logic low) potential. To prevent damage to the compressor motor and chilled water pump motor, anti-chatter circuits are used to control the chilled water pump relay (J7-3) (K3) and the motor starter relay (J7-5) (K9). The anti-chatter circuits prevent K3 from energizing at a rate greater than once every 15 seconds and K9 every 30 seconds.

A chiller identification switch (S1) is provided for use when YORK “FAX-4500” energy management system or local system status printer is connected to the Micro

Board serial data ports. The chiller ID switch can be used to assign an identification number (0 thru 7) to each chiller. If a local system status printer is applied, this number is printed at the top of each printout. Refer to YORK Form 160.49-N2 for details of printer applications. This ID is useful in multiple chiller installations to identify individual printouts from different chillers.

Since the Micro Boards are universal in application, program jumpers are provided to configure for different applications. Refer to Fig. 31 for explanation of each program jumper.

MICRO BOARD – INPUTS AND OUTPUTS (PLUG PIN NO'S.) (Refer to Fig. 27 for pin identification)

J1-26 — Not used.

J1-25—Low evaporator pressure safety (Brine applications only). 0 VDC when external LEP safety indicated a low pressure condition.

J1-24—Auxilliary safety shutdown. +5VDC when optional external device has initiated a shutdown.

J1-23—Spare

J1-22—Not Used

J1-21—Multi-unit sequence. +5VDC when sequence kit enables compressor to run; or when jumper is installed at input to digital input board.

J1-20—Local/remote cycling device. +5VDC when remote cycling device enables the compressor to run; or when jumper is installed at input to digital input board.

J1-19—Chilled water pump interlock or flowswitch. +5VDC when interlock or flowswitch enables compressor to run.

***J1-18**—Remote current limit setpoint (EMS). A 1-11 sec pulse width modulated (PWM) signal that is +5VDC in the active state. Signal is only accepted every 60 seconds—any signal received at a rate greater than 1 signal/60 seconds will be ignored.

***J1-17**—Remote LCWT setpoint (EMS). A 1-11 sec Pulse Width Modulated (PWM) signal that is +5VDC in the active state. Signal is only accepted every 60 seconds. Any signal received at a rate greater than 1 signal/60 seconds will be ignored.

J1-16—Remote stop (EMS). +5VDC when remote EMS has commanded the compressor to stop. This must be a maintained signal to provide a stop function.

J1-15—Remote start (EMS) +5VDC when remote EMS has commanded the compressor to start. This signal need only be a momentary signal to initiate start but a maintained signal is recommended.

J1-14— +5VDC unreg. power supply (+10VDC)

J1-13—5V ret.

J1-12—Not used.

J1-11—Not used.

J1-10—Not used.

J1-9—Start. +5VDC when compressor switch is in **START** position.

J1-8—Stop. +5VDC when compressor switch is in stop position.

J1-7—Motor controller. 0 VDC when motor controller contacts are open indicating a motor controller shutdown.

J1-6—Not used.

J1-5—Not used.

J1-4 — Not used.

J1-3 — Not used.

J1-2 — High pressure. +5VDC when condenser pressure rises to 265 PSIG as indicated by external HP safety. Returns to 0 VDC when pressure falls to 205 PSIG.

J1-1—Vane motor switch. +5VDC when vanes are fully closed.

J2

J2-1—2² address bit to multiplexer on CM-2 module (Electro-Mechanical Starter Applications), LCSSS Logic Board (LCSSS Applications). +12DC in active state. Otherwise 0VDC. (+15VDC—EM Starter).

J2-2 — 2¹ address bit to CM-2 module (Electro-Mechanical Starter Applications), LCSSS Logic Board (LCSSS Applications) +12VDFC in active state. Otherwise 0VDC. (+15VDC-EM starter).

J2-3 — 2⁰ address bit to CM-2 module (Electro-Mechanical Starter Applications), LCSSS Logic Board (LCSSS Applications) +12VDC in active state. Otherwise 0VDC. (+15VDC-EM starter).

* This signal is normally sent from EMS once every 60-90 seconds. However, if a signal is not recieved within 30 minutes of the last signal recieved, the setpoint reverts to the control panel programmed setpoint.

J54 **CHW PMP -**

IN= Causes chilled water pump contacts (Relay Output Board TB4-44/45) to open at completion of system coastdown after all chiller shutdowns except low water temp (LWT) shutdowns. On LWT shutdowns the contacts remain closed, causing the pump to continue to run.

OUT= Causes above contacts to open at completion of system coastdown after all chiller shutdowns except LWT, multi-unit sequence, and remote/local cycling shutdowns. On these shutdowns the contacts remain closed, causing the pump to continue to run.

NOTE: Refer to Relay Output Board "OUTPUTS" section of this instruction.

JP1 **NON T-M / SC (NOT APPLICABLE)**

J53 **SENS -** Leaving chilled water temp. control sensitivity adjustment. Proper operation will be provided in most applications with jumper installed. Removing the jumper reduces the PRV response to LCWT setpoint change or step changes in water temperature. The duration of the initial PRV pulse in response to these conditions is reduced by 50%. Therefore, the sensitivity is reduced. Short chilled water loops, multi-pass or parallel chiller applications might require jumper removal.

J52 **ENGL -**

IN= System pressures and temperatures displayed in PSIA and °F.

OUT= System pressures and temperatures displayed in KPa (Kilo Pascals) and °C respectively.

JP2 **R11 -**

IN= R22 Refrigerant Applications

OUT= R134a Refrigerant Applications

J51 • •

IN= Cancels 30 minute anti-recycle time.

OUT= Enables 30 minute anti-recycle time.

NOTE: Shipped with jumper removed. Never install this jumper unless absolutely necessary during troubleshooting.

J50 • • **AUTO R -**

IN= Enables Auto Restart after power failure feature.

OUT= Enables Manual Restart after power failure feature.

NOTE: Shipped with jumper removed.

JP3 **WATER -**

IN= Water cooling applications (LCWT setpoint 38°F-70°F).

OUT= Brine cooling applications (LCWT setpoint 10°F-45°F).

J55 • **TEST -** In the DISABLE position the software diagnostic is disabled. Shipped with jumper in this position. This is the normal position for operating the chiller.

DIS ENA

• • In the ENABLE position the software diagnostic is enabled. Refer to "TESTING" section of this instruction before putting the jumper in this position.

DIS ENA

J56 • **RS 232 -** In the MODEM position, a modem (Remote Chiller Communications or YORK GUARDIAN SERVICE Application) and/or local printer can be connected to the RS 232 serial port (TB8).

MODEM EMS

MODEM EMS

In the EMS position, the YORK EMS (FAX 4500) can be connected to the RS 485 serial port (Micro Board TB7). A special optional Eprom is required when this interface is used. The remote PWM temp and current setpoint and start/stop inputs to the digital input board cannot be used with the jumper in this position.

JP4 **CSTDN (NOT APPLICABLE)**

Jumper is normally in.

JP5 **CURR UNBAL -**

IN= Enables 30 motor current unbalance detection on Liquid Cooled Solid State Starter applications.

OUT= Disables 30 motor current unbalance detection on Liquid Cooled Solid State Starter applications.

NOTE: Refer to MicroComputer Control Center Operating Instruction (FORM 160.49-O1) "MTR Phase Current Unbalance" shutdown display message.

JP6 **PRERUN -**

IN= Provides 30 second oil pre-lube prior to chiller start. Normal operating position.

OUT= Provides 180 second oil pre-lube prior to chiller start.

JP7 **NOT APPLICABLE**

J57 **CLOCK -**

CLKON CLKOFF

In the CLKON position the RTC CLOCK (Day/TIME/Date) is permitted to run. This is the normal operating position. To turn on clock move jumper to this position while AC power is applied to MicroComputer Control Center, then proceed to program clock setpoint per Operating Instruction (FORM 160.49-O1) . Clock will start when keypad ENTER key is pressed after clock setpoint is programmed.

CLKON CLKOFF

In the CLKOFF position the RTC CLOCK does not run. Shipped with jumper in this position. This position is used for long-term storage, shipping and winter shutdowns when AC power is removed from MicroComputer Control Center. This extends the life of the RTC Battery. To turn off clock, move jumper to this position while AC power is applied to MicroComputer Control Center.

NOTE: System setpoints are retained in this position as long as the battery is OK.

J58 **SERIAL PORT SELECT -** The position of this jumper determines which serial port (RS-232 or RS-485) can be used.

RS-485

RS-232

In this position the RS-232 port (TB8) is enabled. Place in this position when a "York Guardian Service" modem "Remote Chiller Communications" modem or local printer is connected to TB8. If this position is selected, program jumper J56 must be in MODEM position.

RS-485

RS-232

In this position the RS-485 port (TB7) is enabled. Place in this position when the "York FAX-4500" energy management system is connected to TB7. If this position is selected, program jumper J56 must be in EMS position.

SECTION 3D

FIG. 31 - MICRO BOARD PROGRAM JUMPERS
YORK APPLIED SYSTEMS

J2-4— + 5VDC

J2-5—GND

J2-6—Multiplexed 0-5VDC output of CM-2 module (Electro-Mechanical Starter Application) or LCSSS Logic Board (LCSSS Application).

CM-2—MUX Channel 0 = GND.
MUX Channel 7 = Calibrated Motor Current Analog Signal . + 4.0VDC = 100% FLA

LCSSS Logic Board—MUX Channel 0 = Ammeter Scaling (LCSSS Model Detector) and voltmeter range analog signal as follows:

26L/600VAC = 2.75VDC Nominal
33L/600VAC = ≥ 3.88VDC Nominal

MUX Channel 1 = Current Limit command as follows:

< 98% = ≥ 3.46VDC
≥ 100% = 1.21-3.45VDC
≥ 104% = < 1.20VDC

MUX Channel 2, 3, 4 = ØC, ØB, ØA AC line voltage analog signal. Calculate value as follows:

$$600VAC \text{ full scale} = V_{OUT} = \frac{V_{AC}}{135.791}$$

MUX Channel 5, 6, 7 = ØA, ØB, ØC motor current analog 0-4.7VDC signal. LCSSS Logic Board is factory calibrated to provide the following output at full scale amps. It is linear between 0-4.7VDC.

MODEL	FULL SCALE AMPS	OUTPUT
26L	2800A	4.7VDC
33L	3500A	4.7VDC

J3

J3-1—GND

J3-2— + 5VDC unreg. (+ 10VDC)

J4

J4-1— + 5VDC return

J4-2—Keypad output, row-8. This line is driven to GND when Micro Board is scanning row-8. Otherwise + 5VDC.

J4-3—Keypad output, row-10. This line is driven to GND when Micro Board is scanning row-10. Otherwise + 5VDC.

J4-4—Keypad output, row-20. This line is driven to GND when Micro Board is scanning row-20. Otherwise + 5VDC.

J4-5—Keypad output, row-40. This line is driven to GND when Micro Board is scanning row-40. Otherwise + 5VDC.

J4-6—Keypad output, row-4. This line is driven to GND when Micro Board is scanning row-4. Otherwise + 5VDC.

J4-7—Keypad input, column-1, 0VDC when a key in column 01 is pressed. Otherwise, + 5VDC.

J4-8—Keypad input, column-2, 0VDC when a key in column 2 is pressed. Otherwise, + 5VDC.

J4-9—Keypad input, column-4, 0VDC when a key in column 4 is pressed. Otherwise, + 5VDC.

J4-10—Keypad input, column-8, 0VDC when a key in column 8 is pressed. Otherwise, + 5VDC.

J4-11—Keypad input, column-10, 0VDC when a key in column 10 is pressed. Otherwise, + 5VDC.

J4-12—Keypad input, column-20, 0VDC when a key in column 20 is pressed. Otherwise, + 5VDC.

J4-13—Keypad input, column-40, 0VDC when a key in column 40 is pressed. Otherwise, + 5VDC.

J4-14—Keypad input, column-80, 0VDC when a key in column 8 is pressed. Otherwise, + 5VDC.

J4-15—Keypad output, row-80. This line is driven to GND when Micro Board is scanning row-80. Otherwise + 5VDC.

J6

J6-1 — "TØ" output. Control bit that is used to initiate the display self-test. Bit is GND for greater than 3 sec to initiate test. Otherwise + 5VDC.

J6-3— \overline{CS} (Chip Select) output. Control bit that is 0 VDC to enable vacuum fluorescent display module to accept a character. Otherwise, + 5VDC.

J6-5— + 5VDC.

J6-7—"A" output. Not used.

J6-9— \overline{WR} (Write) output. Control bit that is 0 VDC to write a character into the vacuum fluorescent display module. Otherwise, + 5VDC.

J6-11 - 2⁰ bit output. ASCII that is +5VDC in the active state. Otherwise, 0VDC.

J6-13 - 2¹ bit output. ASCII that is +5VDC in the active state. Otherwise, 0VDC.

J6-15 - 2² bit output. ASCII that is +5VDC in the active state. Otherwise, 0VDC.

J6-17 - 2³ bit output. ASCII that is +5VDC in the active state. Otherwise, 0VDC.

J6-19 - 2⁴ bit output. ASCII that is +5VDC in the active state. Otherwise, 0VDC.

J6-21 - 2⁵ bit output. ASCII that is +5VDC in the active state. Otherwise, 0VDC.

J6-23 - 2⁶ bit output. ASCII that is +5VDC in the active state. Otherwise, 0VDC.

J6-25 - 2⁷ bit output. ASCII that is +5VDC in the active state. Otherwise, 0VDC.

J7

J7-1 - Cycling shutdown. 0VDC when Control Center is shutdown on a "Cycling" shutdown. Otherwise, +12VDC. Refer to **RELAY OUTPUT BOARD-OUTPUTS** section (TB4-40/41) for details of "Cycling" shutdown.

J7-2 - Safety shutdown. 0VDC when panel is shutdown on a "Safety" shutdown. Otherwise, +12VDC. Refer to **RELAY OUTPUT BOARD-OUTPUTS** section (TB4-42/43) for details of "Safety" shutdown.

J7-3 - Chilled water pump. 0VDC when panel is commanding the chilled water pump to run. Otherwise, +12VDC. Refer to **RELAY OUTPUT BOARD-OUTPUTS** section (TB4-44/45) for details of "Chilled Water Pump" contacts. An anti-chatter circuit on the Micro Board prevents the output from energizing the chilled water pump at a rate greater than once every 10 seconds.

J7-4 - Remote mode ready to start. 0VDC when all safeties and cycling devices are satisfied and the keyswitch is in the **REMOTE** mode. Otherwise, +12VDC.

J7-5 - Motor starter "Start". 0VDC for 200 milliseconds to start compressor motor. Then transitions to +12VDC.

J7-6 - High Speed thrust bearing solenoid. 0VDC when Micro Board energizes (opens) the valve. This occurs 15 seconds after the compressor motor starts. +12VDC when the Micro Board de-energizes (closes) the valve. This occurs coincident with removing the start signal from the compressor motor starter.

J7-7 - Oil Return. 0 VDC when the Micro Board is commanding the oil return solenoid valve to energize. Otherwise, +12 VDC.

J7-8 - Motor starter "Stop". 0VDC to start and run compressor motor. +12VDC to stop compressor motor.

J7-9 - Vent line and liquid line solenoids, 0VDC when Micro Board is commanding them to energize (open). Otherwise, 12VDC.

J7-10 - Oil pump. 0VDC when Micro Board is commanding the oil pump to run. Otherwise, +12 VDC.

J7-11 - Vane close. 0VAC as measured to J7-12 when Micro Board is commanding the vanes to close. Approximately 24VAC - 28VAC when vanes are holding or opening.

J7-13 - Vane open. 0VAC as measured to J7-14 when Micro Board is commanding the vanes to open. Approximately 24VAC - 28VAC when vanes are holding or closing.

J7-15 - Not used.

J7-16 - Not used.

J7-17 - 12V return (GND).

J7-18 - 12V return (GND).

J8

J8-1 - Cardfile interface current loop serial port connector. Reserved for future use.

J8-2 - GND.

J8-3 - Not used.

J8-4 - Cardfile current loop serial port interface connector transmitter. For future use.

J10 - Not used.

TB7-3 - RS-485 Serial Port Ground.

TB7-1 - RS-485 Serial Port balanced (+) I/O line. Greater than +.2VDC with respect to (-) line (TB1-3) is a Logic 1 (Mark). Greater than -.2VDC is a Logic 0 (Space). Baud rate is determined by the application.

TB7-2 - RS-485 Serial Port balanced (-) I/O line. See TB1-2.

TB8 - RS-232C Serial Port. Used for:

- System Status Printer (160.49-N2)
- YORK Guardian Service
- Remote Chiller Communication

TB8-1 - DTR (Data Terminal Ready) - Control signal to remote device. Logic high (+5 to +25VDC) when Micro Board is ready to transmit or receive data from remote device.

TB8-2 -DSR (Data Set Ready) - Control signal from remote device. Logic high (+5 to +25VDC) when remote device is ready to receive or transmit data to Micro Board.

TB8-3 - TXD (Transmit Data) - Serial data to remote device. Logic 1 = -5 to -25VDC. Logic 0 = +5 to +25VDC. Baud rate is determined by the application.

TB8-4 - RXD (Receive Data) - Serial data from remote device. Logic 1 = -5 to -25VDC. Logic 0 = +5 to +25VDC.

TB8-5 - Micro Board Ground

TB8-6 - Micro Board + 5 VDC.

J17

J17-1 - 5V RET

J17-2 - Not used.

J17-6 - + 5VDC

J17-11 - Oil pressure transducer input (oil filter discharge - high side) .5 - 4.5VDC transducer output [as measured to ground (J17-2)]. To calculate the transducer output voltage vs. a given input pressure, use the formulas in Fig. 32.

Note that the oil pressure is being monitored at both the oil filter discharge point and PRV inlet point. The microprocessor subtracts the two values and displays "Differential Oil Pressure" as follows:

$$\text{Oil Filter Discharge P} - \text{PRV Inlet P} = \text{PSID}$$

J17-4 - Not used.

J17-3 - 5V RET

J17-8 - +5VDC

J17-13 - Oil pressure transducer input (PRV Input Point - Low side). .5 - 4.5VDC transducer output [as measured to ground (J17-3)]. Refer to Table 1 for applicable transducer.

To calculate the transducer output voltage vs. a given input pressure; use the appropriate formula in Fig. 32 or 33.

Note that the oil pressure is being monitored at both the oil filter discharge points and PRV Inlet Point. The

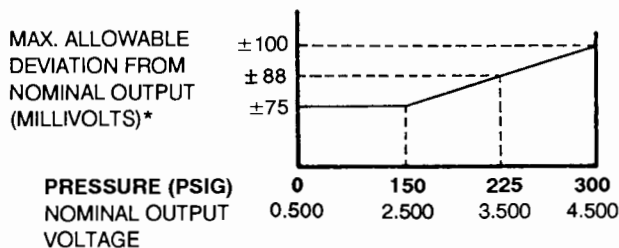

FIG. 32 — PRESSURE TRANSDUCER (Ref. Table 1 for applications) YORK P/N 025-28678-001

$$V = \frac{P + 37.5}{75} \quad P = (75 \times V) - 37.5$$

V = Volts DC P = Pressure (PSIG)

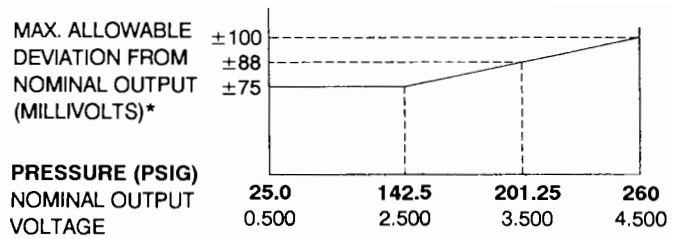

FIG. 33 — OIL PRESSURE (LOW SIDE) - R22 WATER & BRINE APPLICATIONS (Ref. Table 1) YORK P/N 025-28678-004

$$V = \frac{P + 4.375}{58.75} \quad P = (58.75 \times V) - 4.375$$

V = Volts DC P = Pressure (PSIG)

micro-processor subtracts the two values and displays "Differential Oil Pressure" as follows:

$$\text{Oil Filter Discharge P} - \text{PRV Inlet P} = \text{PSID}$$

J17-5 - Not Used.

J17-10 - 5V RET

J17-9 - +5VDC

J17-15 - Position sensor output of proximity and temperature sensor module. 0.5 - 4.5VDC (as measured to ground J23-2) corresponding to 0-99 MILS measured distance as follows:

Where D = Distance in MILS
V = VOLTS DC

$$V = \frac{D - 4.14}{20.86} \quad D = 20.86 \times V + 4.14$$

J19

J19-2 - Not Used.

J19-1 - 5V RET

J19-5 - +5VDC

J19-9 - Evaporator pressure transducer input. .5 - 4.5 VDC transducer output [as measured to ground (J19-1)]. Refer to Table 1 for applicable transducer.

To calculate the transducer output voltage vs. a given input pressure, use the appropriate formula in Fig. 34, 35 or 35A.

TABLE 1 - Pressure Transducer Applications Chart

TRANSDUCER PART NUMBER	FUNCTION	R22 APPLICATION	
		WATER	BRINE
025-28678-001	CONDENSER, HI OIL	X	X
025-28678-002	EVAPORATOR	X	
025-28678-003	EVAPORATOR		X
025-28678-004	LO OIL	X	X
R134a			
025-28678-001	CONDENSER, HI & LO OIL	X	X
025-28678-005	EVAPORATOR	X	X

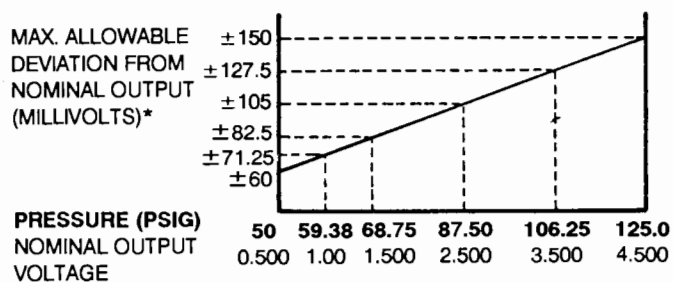

FIG. 34 — EVAPORATOR TRANSDUCER (R22 WATER APPLICATIONS) Ref. Table 1 YORK P/N 025-28678-002

$$V = \frac{(P \times 4) - 162.5}{75} \quad P = \frac{(75 \times V) + 162.5}{4}$$

V = Volts DC P = Pressure (PSIG)

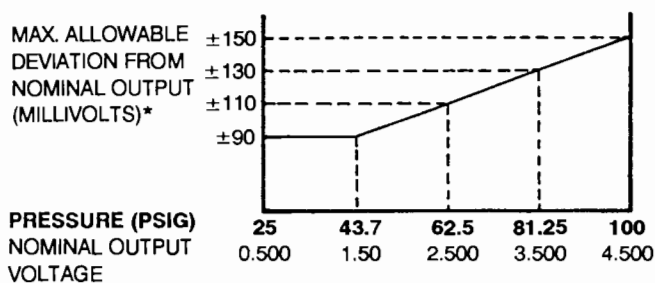

FIG. 35 — EVAPORATOR TRANSDUCER (R22 Brine Applications) Ref. Table 1 YORK P/N 025-28678-003

$$V = \frac{P - 15.6}{18.75} \quad P = 18.75 \times V + 15.6$$

V = Volts DC P = Pressure (PSIG)

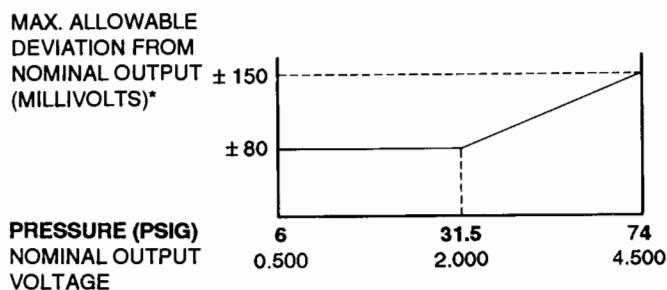

FIG. 35A- EVAPORATOR TRANSDUCER (R134a Water & Brine Applications) Ref. Table 1 YORK P/N 025-28678-005

$$V = \frac{P + 2.5}{17} \quad P = (17 \times V) - 2.5$$

V = Volts DC P = Pressure (PSIG)

J19-4 - Not used.

J19-8 - 5V RET.

J19-7 - +5VDC.

YORK APPLIED SYSTEMS

J19-12 - Condenser pressure transducer input. .5 - 4.5 VDC transducer output [as measured to ground (J19-8)]. To calculate the transducer output voltage vs. a given input pressure, use the formula in Fig. 32.

J19-6 - +5VDC to leaving chilled water temp thermistor.

J19-10 - Leaving chilled water temp thermistor input to Micro Board. 0-5VDC. Refer to Table 2 for Temperature/Voltage Chart.

J19-3 - Not used.

J21-4 - +5VDC to entering chilled water temp thermistor.

J21-7 - Entering chilled water temp thermistor input to Micro Board. 0-5VDC. Refer to Table 3 for Temperature/Voltage Chart.

J21-1 - Not used.

J21-5 - +5VDC to oil temp thermistor.

J21-8 - Oil temp thermistor input to Micro Board. 0-5VDC. Refer to Table 4 for Temperature/Voltage Chart.

J21-2 - Not used.

J21-6 - +5VDC to discharge temp thermistor.

J21-9 - Discharge temp thermistor input to Micro Board. 0-5VDC. Refer to Table 4 for Temperature/Voltage Chart.

J21-3 - Not used.

J22-4 - +5VDC to entering condenser water temp thermistor.

J22-5 - Entering condenser water temp thermistor input to Micro Board. 0-5VDC. Refer to Table 5 for Temperature/Voltage Chart.

J22-1 - Not used.

J22-2 - +5VDC to leaving condenser water temp thermistor.

J22-6 - Leaving condenser water temp thermistor input to Micro Board. 0-5VDC. Refer to Table 5 for Temperature/Voltage Chart.

J23-2 - 5V RET.

J23-3 - +5VDC to proximity and temperature sensor module.

J23-4 - Temperature sensor output of proximity and temperature sensor module. 0.5VDC-4.5VDC (as measured to ground J23-2) corresponding to 0-300°F sensor temperature as follows:

$$V = \frac{T - 18.75}{62.5} \quad T = 62.5 \times V + 18.75$$

Where: V = Volts DC T = Temperature in °F

SECTION
3D

TABLE 2 — LEAVING CHILLED WATER TEMP.

temp(F)	Vin	temp(F)	Vin	temp(F)	Vin	temp(F)	Vin
9.90	1.4280	15.13	1.5957	20.17	1.7634	25.08	1.9311
10.00	1.4310	15.22	1.5987	20.26	1.7664	25.17	1.9341
10.09	1.4341	15.32	1.6018	20.35	1.7695	25.26	1.9372
10.19	1.4371	15.41	1.6048	20.44	1.7725	25.35	1.9402
10.29	1.4402	15.50	1.6079	20.53	1.7756	25.43	1.9433
10.39	1.4432	15.60	1.6109	20.62	1.7786	25.52	1.9463
10.48	1.4463	15.69	1.6140	20.71	1.7817	25.61	1.9494
10.58	1.4493	15.78	1.6170	20.80	1.7847	25.70	1.9524
10.68	1.4523	15.87	1.6201	20.89	1.7878	25.79	1.9555
10.77	1.4554	15.97	1.6231	20.98	1.7908	25.87	1.9585
10.87	1.4584	16.06	1.6262	21.07	1.7939	25.96	1.9616
10.97	1.4615	16.15	1.6292	21.16	1.7969	26.05	1.9646
11.06	1.4645	16.24	1.6322	21.25	1.8000	26.14	1.9677
11.16	1.4676	16.34	1.6353	21.34	1.8030	26.23	1.9707
11.25	1.4706	16.43	1.6383	21.43	1.8060	26.31	1.9738
11.35	1.4737	16.52	1.6414	21.52	1.8091	26.40	1.9768
11.45	1.4767	16.61	1.6444	21.61	1.8121	26.49	1.9798
11.54	1.4798	16.70	1.6475	21.70	1.8152	26.58	1.9829
11.64	1.4828	16.80	1.6505	21.79	1.8182	26.67	1.9859
11.73	1.4859	16.89	1.6536	21.88	1.8213	26.76	1.9890
11.83	1.4889	16.98	1.6566	21.97	1.8243	26.84	1.9920
11.93	1.4920	17.07	1.6597	22.06	1.8274	26.93	1.9951
12.02	1.4950	17.16	1.6627	22.15	1.8304	27.02	1.9981
12.12	1.4981	17.26	1.6658	22.24	1.8335	27.11	2.0012
12.21	1.5011	17.35	1.6688	22.33	1.8365	27.20	2.0042
12.31	1.5042	17.44	1.6719	22.42	1.8396	27.28	2.0073
12.40	1.5072	17.53	1.6749	22.51	1.8426	27.37	2.0103
12.50	1.5103	17.63	1.6780	22.60	1.8457	27.46	2.0134
12.59	1.5133	17.72	1.6810	22.69	1.8487	27.55	2.0164
12.69	1.5164	17.81	1.6841	22.78	1.8518	27.64	2.0195
12.78	1.5194	17.90	1.6871	22.87	1.8548	27.73	2.0225
12.88	1.5225	17.99	1.6902	22.96	1.8579	27.81	2.0256
12.97	1.5255	18.08	1.6932	23.04	1.8609	27.90	2.0286
13.07	1.5286	18.17	1.6963	23.13	1.8640	27.99	2.0317
13.16	1.5316	18.26	1.6993	23.22	1.8670	28.08	2.0347
13.26	1.5347	18.35	1.7024	23.31	1.8701	28.17	2.0378
13.35	1.5377	18.44	1.7054	23.40	1.8731	28.25	2.0408
13.45	1.5408	18.54	1.7085	23.49	1.8762	28.34	2.0439
13.54	1.5438	18.63	1.7115	23.58	1.8792	28.43	2.0469
13.64	1.5469	18.72	1.7146	23.67	1.8823	28.52	2.0500
13.73	1.5499	18.81	1.7176	23.75	1.8853	28.61	2.0530
13.83	1.5530	18.90	1.7207	23.84	1.8884	28.69	2.0561
13.92	1.5560	18.99	1.7237	23.93	1.8914	28.78	2.0591
14.01	1.5591	19.08	1.7268	24.02	1.8945	28.87	2.0622
14.11	1.5621	19.17	1.7298	24.11	1.8975	28.96	2.0652
14.20	1.5652	19.26	1.7329	24.20	1.9006	29.04	2.0683
14.29	1.5682	19.36	1.7359	24.29	1.9036	29.13	2.0713
14.39	1.5713	19.45	1.7390	24.37	1.9067	29.22	2.0744
14.48	1.5743	19.54	1.7420	24.46	1.9097	29.31	2.0774
14.57	1.5774	19.63	1.7451	24.55	1.9128	29.39	2.0805
14.67	1.5804	19.72	1.7481	24.64	1.9158	29.48	2.0835
14.76	1.5835	19.81	1.7512	24.73	1.9189	29.57	2.0866
14.85	1.5865	19.90	1.7542	24.82	1.9219	29.66	2.0896
14.95	1.5896	19.99	1.7573	24.91	1.9250	29.75	2.0927
15.04	1.5926	20.08	1.7603	24.99	1.9280	29.83	2.0957

TABLE 2 — LEAVING CHILLED WATER TEMP. - (Continued)

temp(F)	Vin	temp(F)	Vin	temp(F)	Vin	temp(F)	Vin	temp(F)	Vin
29.92	2.0988	34.73	2.2665	39.57	2.4342	44.46	2.6019	49.48	2.7696
30.01	2.1018	34.82	2.2695	39.66	2.4372	44.55	2.6049	49.57	2.7726
30.10	2.1049	34.91	2.2726	39.74	2.4403	44.64	2.6080	49.66	2.7757
30.18	2.1079	34.99	2.2756	39.83	2.4433	44.73	2.6110	49.75	2.7787
30.27	2.1110	35.08	2.2787	39.92	2.4464	44.82	2.6141	49.84	2.7818
30.36	2.1140	35.17	2.2817	40.01	2.4494	44.91	2.6171	49.94	2.7848
30.45	2.1171	35.26	2.2848	40.10	2.4525	45.00	2.6202	50.03	2.7879
30.53	2.1201	35.34	2.2878	40.19	2.4555	45.09	2.6232	50.12	2.7909
30.62	2.1232	35.43	2.2909	40.27	2.4586	45.18	2.6263	50.22	2.7940
30.71	2.1262	35.52	2.2939	40.36	2.4616	45.27	2.6293	50.31	2.7970
30.79	2.1293	35.61	2.2970	40.45	2.4647	45.36	2.6324	50.40	2.8001
30.88	2.1323	35.70	2.3000	40.54	2.4677	45.46	2.6354	50.50	2.8031
30.97	2.1354	35.78	2.3031	40.63	2.4708	45.55	2.6385	50.59	2.8062
31.06	2.1384	35.87	2.3061	40.71	2.4738	45.64	2.6415	50.68	2.8092
31.14	2.1415	35.96	2.3092	40.80	2.4769	45.73	2.6446	50.78	2.8123
31.23	2.1445	36.05	2.3122	40.89	2.4799	45.82	2.6476	50.87	2.8153
31.32	2.1476	36.13	2.3153	40.98	2.4830	45.91	2.6507	50.96	2.8184
31.41	2.1506	36.22	2.3183	41.07	2.4860	46.00	2.6537	51.06	2.8214
31.49	2.1536	36.31	2.3214	41.16	2.4891	46.09	2.6568	51.15	2.8245
31.58	2.1567	36.40	2.3244	41.24	2.4921	46.18	2.6598	51.24	2.8275
31.67	2.1597	36.48	2.3274	41.33	2.4952	46.27	2.6629	51.34	2.8306
31.76	2.1628	36.57	2.3305	41.42	2.4982	46.36	2.6659	51.43	2.8336
31.84	2.1658	36.66	2.3335	41.51	2.5012	46.45	2.6690	51.52	2.8367
31.93	2.1689	36.75	2.3366	41.60	2.5043	46.55	2.6720	51.62	2.8397
32.02	2.1719	36.83	2.3396	41.69	2.5073	46.64	2.6751	51.71	2.8428
32.10	2.1750	36.92	2.3427	41.78	2.5104	46.73	2.6781	51.80	2.8458
32.19	2.1780	37.01	2.3457	41.87	2.5134	46.82	2.6811	51.90	2.8489
32.28	2.1811	37.10	2.3488	41.96	2.5165	46.91	2.6842	51.99	2.8519
32.37	2.1841	37.18	2.3518	42.05	2.5195	47.00	2.6872	52.09	2.8549
32.45	2.1872	37.27	2.3549	42.14	2.5226	47.09	2.6903	52.18	2.8580
32.54	2.1902	37.36	2.3579	42.23	2.5256	47.18	2.6933	52.28	2.8610
32.63	2.1933	37.45	2.3610	42.31	2.5287	47.27	2.6964	52.37	2.8641
32.72	2.1963	37.54	2.3640	42.40	2.5317	47.36	2.6994	52.46	2.8671
32.81	2.1994	37.62	2.3671	42.49	2.5348	47.45	2.7025	52.56	2.8702
32.89	2.2024	37.71	2.3701	42.58	2.5378	47.55	2.7055	52.65	2.8732
32.98	2.2055	37.80	2.3732	42.67	2.5409	47.64	2.7086	52.75	2.8763
33.07	2.2085	37.89	2.3762	42.76	2.5439	47.73	2.7116	52.84	2.8793
33.16	2.2116	37.98	2.3793	42.85	2.5470	47.82	2.7147	52.94	2.8824
33.24	2.2146	38.07	2.3823	42.94	2.5500	47.91	2.7177	53.03	2.8854
33.33	2.2177	38.15	2.3854	43.03	2.5531	48.00	2.7208	53.13	2.8885
33.42	2.2207	38.24	2.3884	43.12	2.5561	48.09	2.7238	53.22	2.8915
33.51	2.2238	38.33	2.3915	43.21	2.5592	48.18	2.7269	53.32	2.8946
33.59	2.2268	38.42	2.3945	43.30	2.5622	48.27	2.7299	53.41	2.8976
33.68	2.2299	38.51	2.3976	43.39	2.5653	48.37	2.7330	53.51	2.9007
33.77	2.2329	38.60	2.4006	43.48	2.5683	48.46	2.7360	53.60	2.9037
33.86	2.2360	38.69	2.4037	43.57	2.5714	48.55	2.7391	53.70	2.9068
33.94	2.2390	38.77	2.4067	43.65	2.5744	48.64	2.7421	53.79	2.9098
34.03	2.2421	38.86	2.4098	43.74	2.5775	48.74	2.7452	53.89	2.9129
34.12	2.2451	38.95	2.4128	43.83	2.5805	48.83	2.7482	53.98	2.9159
34.21	2.2482	39.04	2.4159	43.92	2.5836	48.92	2.7513	54.08	2.9190
34.29	2.2512	39.13	2.4189	44.01	2.5866	49.01	2.7543	54.17	2.9220
34.38	2.2543	39.22	2.4220	44.10	2.5897	49.11	2.7574	54.27	2.9251
34.47	2.2573	39.30	2.4250	44.19	2.5927	49.20	2.7604	54.36	2.9281
34.56	2.2604	39.39	2.4281	44.28	2.5958	49.29	2.7635	54.46	2.9312
34.64	2.2634	39.48	2.4311	44.37	2.5988	49.38	2.7665	54.55	2.9342

SECTION
3D

TABLE 2 — LEAVING CHILLED WATER TEMP. - (Continued)

temp(F)	Vin	temp(F)	Vin	temp(F)	Vin	temp(F)	Vin	temp(F)	Vin
54.65	2.9373	60.05	3.1050	65.75	3.2727	71.83	3.4404	78.42	3.6081
54.74	2.9403	60.15	3.1080	65.85	3.2757	71.95	3.4434	78.55	3.6111
54.84	2.9434	60.25	3.1111	65.96	3.2788	72.06	3.4465	78.67	3.6142
54.93	2.9464	60.36	3.1141	66.06	3.2818	72.18	3.4495	78.80	3.6172
55.03	2.9495	60.46	3.1172	66.17	3.2849	72.29	3.4526	78.93	3.6203
55.12	2.9525	60.56	3.1202	66.28	3.2879	72.41	3.4556	79.05	3.6233
55.22	2.9556	60.66	3.1233	66.39	3.2910	72.52	3.4587	79.18	3.6264
55.32	2.9586	60.76	3.1263	66.49	3.2940	72.64	3.4617	79.31	3.6294
55.41	2.9617	60.86	3.1294	66.60	3.2971	72.75	3.4648	79.44	3.6325
55.51	2.9647	60.96	3.1324	66.71	3.3001	72.87	3.4678	79.57	3.6355
55.61	2.9678	61.06	3.1355	66.82	3.3032	72.98	3.4709	79.69	3.6386
55.70	2.9708	61.17	3.1385	66.93	3.3062	73.10	3.4739	79.82	3.6416
55.80	2.9739	61.27	3.1416	67.03	3.3093	73.21	3.4770	79.95	3.6447
55.90	2.9769	61.37	3.1446	67.14	3.3123	73.33	3.4800	80.08	3.6477
56.00	2.9800	61.47	3.1477	67.25	3.3154	73.44	3.4831	80.20	3.6508
56.09	2.9830	61.57	3.1507	67.36	3.3184	73.56	3.4861	80.33	3.6538
56.19	2.9861	61.67	3.1538	67.47	3.3215	73.68	3.4892	80.46	3.6569
56.29	2.9891	61.78	3.1568	67.58	3.3245	73.80	3.4922	80.59	3.6599
56.39	2.9922	61.88	3.1599	67.68	3.3276	73.92	3.4953	80.72	3.6630
56.48	2.9952	61.98	3.1629	67.79	3.3306	74.04	3.4983	80.85	3.6660
56.58	2.9983	62.08	3.1660	67.90	3.3337	74.16	3.5014	80.98	3.6691
56.68	3.0013	62.18	3.1690	68.01	3.3367	74.28	3.5044	81.11	3.6721
56.78	3.0044	62.28	3.1721	68.12	3.3398	74.40	3.5075	81.24	3.6752
56.87	3.0074	62.39	3.1751	68.23	3.3428	74.52	3.5105	81.37	3.6782
56.97	3.0105	62.49	3.1782	68.34	3.3459	74.64	3.5136	81.50	3.6813
57.07	3.0135	62.59	3.1812	68.45	3.3489	74.75	3.5166	81.63	3.6843
57.17	3.0166	62.69	3.1843	68.56	3.3520	74.87	3.5197	81.76	3.6874
57.26	3.0196	62.80	3.1873	68.67	3.3550	74.99	3.5227	81.89	3.6904
57.36	3.0227	62.90	3.1904	68.78	3.3581	75.11	3.5258	82.02	3.6935
57.46	3.0257	63.01	3.1934	68.90	3.3611	75.23	3.5288	82.15	3.6965
57.56	3.0287	63.11	3.1965	69.01	3.3642	75.35	3.5319	82.28	3.6996
57.66	3.0318	63.22	3.1995	69.12	3.3672	75.47	3.5349	82.41	3.7026
57.76	3.0348	63.32	3.2025	69.23	3.3703	75.60	3.5380		
57.86	3.0379	63.43	3.2056	69.34	3.3733	75.72	3.5410		
57.96	3.0409	63.53	3.2086	69.45	3.3763	75.84	3.5441		
58.06	3.0440	63.63	3.2117	69.56	3.3794	75.96	3.5471		
58.15	3.0470	63.74	3.2147	69.67	3.3824	76.08	3.5501		
58.25	3.0501	63.84	3.2178	69.78	3.3855	76.20	3.5532		
58.35	3.0531	63.95	3.2208	69.89	3.3885	76.32	3.5562		
58.45	3.0562	64.05	3.2239	70.01	3.3916	76.44	3.5593		
58.55	3.0592	64.16	3.2269	70.12	3.3946	76.57	3.5623		
58.65	3.0623	64.26	3.2300	70.24	3.3977	76.69	3.5654		
58.75	3.0653	64.37	3.2330	70.35	3.4007	76.81	3.5684		
58.85	3.0684	64.47	3.2361	70.46	3.4038	76.93	3.5715		
58.95	3.0714	64.58	3.2391	70.58	3.4068	77.05	3.5745		
59.05	3.0745	64.68	3.2422	70.69	3.4099	77.18	3.5776		
59.15	3.0775	64.79	3.2452	70.80	3.4129	77.30	3.5806		
59.25	3.0806	64.90	3.2483	70.92	3.4160	77.43	3.5837		
59.35	3.0836	65.00	3.2513	71.03	3.4190	77.55	3.5867		
59.45	3.0867	65.11	3.2544	71.15	3.4221	77.68	3.5898		
59.55	3.0897	65.21	3.2574	71.26	3.4251	77.80	3.5928		
59.65	3.0928	65.32	3.2605	71.37	3.4282	77.93	3.5959		
59.75	3.0958	65.43	3.2635	71.49	3.4312	78.05	3.5989		
59.85	3.0989	65.53	3.2666	71.60	3.4343	78.17	3.6020		
59.95	3.1019	65.64	3.2696	71.72	3.4373	78.30	3.6050		

TABLE 3 — ENTERING CHILLED WATER TEMP.

temp(F)	Vin	temp(F)	Vin	temp(F)	Vin	temp(F)	Vin
15.01	1.5918	23.03	1.8604	30.78	2.1289	38.51	2.3975
15.16	1.5967	23.17	1.8652	30.92	2.1338	38.65	2.4023
15.31	1.6016	23.31	1.8701	31.06	2.1387	38.79	2.4072
15.46	1.6064	23.45	1.8750	31.20	2.1436	38.93	2.4121
15.61	1.6113	23.60	1.8799	31.34	2.1484	39.07	2.4170
15.76	1.6162	23.74	1.8848	31.48	2.1533	39.21	2.4219
15.91	1.6211	23.88	1.8896	31.62	2.1582	39.35	2.4268
16.05	1.6260	24.02	1.8945	31.76	2.1631	39.50	2.4316
16.20	1.6309	24.16	1.8994	31.90	2.1680	39.64	2.4365
16.35	1.6357	24.31	1.9043	32.04	2.1729	39.78	2.4414
16.50	1.6406	24.45	1.9092	32.18	2.1777	39.92	2.4463
16.64	1.6455	24.59	1.9141	32.32	2.1826	40.06	2.4512
16.79	1.6504	24.73	1.9189	32.46	2.1875	40.20	2.4561
16.94	1.6553	24.87	1.9238	32.60	2.1924	40.34	2.4609
17.09	1.6602	25.01	1.9287	32.74	2.1973	40.48	2.4658
17.23	1.6650	25.16	1.9336	32.88	2.2021	40.62	2.4707
17.38	1.6699	25.30	1.9385	33.02	2.2070	40.76	2.4756
17.53	1.6748	25.44	1.9434	33.16	2.2119	40.91	2.4805
17.68	1.6797	25.58	1.9482	33.30	2.2168	41.05	2.4854
17.82	1.6846	25.72	1.9531	33.44	2.2217	41.19	2.4902
17.97	1.6895	25.86	1.9580	33.59	2.2266	41.33	2.4951
18.11	1.6943	26.00	1.9629	33.73	2.2314	41.48	2.5000
18.26	1.6992	26.14	1.9678	33.87	2.2363	41.62	2.5049
18.41	1.7041	26.28	1.9727	34.01	2.2412	41.76	2.5098
18.55	1.7090	26.42	1.9775	34.15	2.2461	41.90	2.5146
18.70	1.7139	26.56	1.9824	34.29	2.2510	42.05	2.5195
18.84	1.7188	26.71	1.9873	34.43	2.2559	42.19	2.5244
18.99	1.7236	26.85	1.9922	34.57	2.2607	42.33	2.5293
19.13	1.7285	26.99	1.9971	34.71	2.2656	42.48	2.5342
19.28	1.7334	27.13	2.0020	34.85	2.2705	42.62	2.5391
19.43	1.7383	27.27	2.0068	34.99	2.2754	42.76	2.5439
19.57	1.7432	27.41	2.0117	35.13	2.2803	42.90	2.5488
19.71	1.7480	27.55	2.0166	35.27	2.2852	43.05	2.5537
19.86	1.7529	27.70	2.0215	35.41	2.2900	43.19	2.5586
20.00	1.7578	27.84	2.0264	35.55	2.2949	43.33	2.5635
20.15	1.7627	27.98	2.0313	35.69	2.2998	43.48	2.5684
20.29	1.7676	28.12	2.0361	35.83	2.3047	43.62	2.5732
20.44	1.7725	28.26	2.0410	35.97	2.3096	43.76	2.5781
20.58	1.7773	28.40	2.0459	36.11	2.3145	43.91	2.5830
20.73	1.7822	28.54	2.0508	36.25	2.3193	44.05	2.5879
20.87	1.7871	28.68	2.0557	36.39	2.3242	44.19	2.5928
21.01	1.7920	28.82	2.0605	36.53	2.3291	44.34	2.5977
21.16	1.7969	28.96	2.0654	36.67	2.3340	44.48	2.6025
21.30	1.8018	29.10	2.0703	36.81	2.3389	44.62	2.6074
21.45	1.8066	29.24	2.0752	36.95	2.3438	44.77	2.6123
21.59	1.8115	29.38	2.0801	37.09	2.3486	44.91	2.6172
21.73	1.8164	29.52	2.0850	37.23	2.3535	45.06	2.6221
21.88	1.8213	29.66	2.0898	37.37	2.3584	45.20	2.6270
22.02	1.8262	29.80	2.0947	37.51	2.3633	45.35	2.6318
22.17	1.8311	29.94	2.0996	37.66	2.3682	45.49	2.6367
22.31	1.8359	30.08	2.1045	37.80	2.3730	45.64	2.6416
22.45	1.8408	30.22	2.1094	37.94	2.3779	45.79	2.6465
22.60	1.8457	30.36	2.1143	38.08	2.3828	45.93	2.6514
22.74	1.8506	30.50	2.1191	38.22	2.3877	46.08	2.6563
22.88	1.8555	30.64	2.1240	38.36	2.3926	46.22	2.6611

TABLE 3 — ENTERING CHILLED WATER TEMP. - (Continued)

temp(F)	Vin	temp(F)	Vin	temp(F)	Vin	temp(F)	Vin
46.37	2.6660	54.56	2.9346	63.34	3.2031	73.01	3.4717
46.51	2.6709	54.72	2.9395	63.51	3.2080	73.20	3.4766
46.66	2.6758	54.87	2.9443	63.68	3.2129	73.38	3.4814
46.80	2.6807	55.02	2.9492	36.84	3.2178	73.57	3.4863
46.95	2.6855	55.17	2.9541	64.01	3.2227	73.76	3.4912
47.09	2.6904	55.33	2.9590	64.18	3.2275	73.95	3.4961
47.24	2.6953	55.48	2.9639	64.34	3.2324	74.14	3.5010
47.39	2.7002	55.64	2.9688	64.51	3.2373	74.33	3.5059
47.53	2.7051	55.79	2.9736	64.68	3.2422	74.53	3.5107
47.68	2.7100	55.95	2.9785	64.85	3.2471	74.72	3.5156
47.82	2.7148	56.11	2.9834	65.02	3.2520	74.91	3.5205
47.97	2.7197	56.26	2.9883	65.19	3.2568	75.10	3.5254
48.11	2.7246	56.42	2.9932	65.36	3.2617	75.29	3.5303
48.26	2.7295	56.57	2.9980	65.53	3.2666	75.48	3.5352
48.41	2.7344	56.73	3.0029	65.70	3.2715	75.68	3.5400
48.56	2.7393	56.89	3.0078	65.87	3.2764	75.87	3.5449
48.70	2.7441	57.04	3.0127	66.04	3.2813	76.07	3.5498
48.85	2.7490	57.20	3.0176	66.21	3.2861	76.26	3.5547
49.00	2.7539	57.36	3.0225	66.39	3.2910	76.46	3.5596
49.15	2.7588	57.51	3.0273	66.56	3.2959	76.65	3.5645
49.30	2.7637	57.67	3.0322	66.73	3.3008	76.84	3.5693
49.44	2.7686	57.83	3.0371	66.91	3.3057	77.04	3.5742
49.59	2.7734	57.99	3.0420	67.08	3.3105	77.24	3.5791
49.74	2.7783	58.15	3.0469	67.25	3.3154	77.44	3.5840
49.89	2.7832	58.31	3.0518	67.43	3.3203	77.64	3.5889
50.04	2.7881	58.47	3.0566	67.60	3.3252	77.84	3.5938
50.19	2.7930	58.62	3.0615	67.77	3.3301	78.04	3.5986
50.34	2.7979	58.78	3.0664	67.95	3.3350	78.24	3.6035
50.48	2.8027	58.94	3.0713	68.12	3.3398	78.44	3.6084
50.63	2.8076	59.10	3.0762	68.30	3.3447	78.64	3.6133
50.78	2.8125	59.26	3.0811	68.48	3.3496	78.84	3.6182
50.93	2.8174	59.42	3.0859	68.66	3.3545	79.04	3.6230
51.08	2.8223	59.59	3.0908	68.83	3.3594	79.25	3.6279
51.23	2.8271	59.75	3.0957	69.01	3.3643	79.45	3.6328
51.38	2.8320	59.91	3.1006	69.19	3.3691	79.66	3.6377
51.53	2.8369	60.07	3.1055	69.36	3.3740	79.86	3.6426
51.68	2.8418	60.23	3.1104	69.54	3.3789	80.07	3.6475
51.83	2.8467	60.39	3.1152	69.72	3.3838	80.27	3.6523
51.98	2.8516	60.55	3.1201	69.90	3.3887	80.48	3.6572
52.13	2.8564	60.72	3.1250	70.08	3.3936	80.68	3.6621
52.28	2.8613	60.88	3.1299	70.26	3.3984	80.89	3.6670
52.44	2.8662	61.04	3.1348	70.45	3.4033	81.10	3.6719
52.59	2.8711	61.20	3.1396	70.63	3.4082	81.31	3.6768
52.74	2.8760	61.37	3.1445	70.81	3.4131	81.52	3.6816
52.89	2.8809	61.53	3.1494	70.99	3.4180	81.72	3.6865
53.04	2.8857	61.69	3.1543	71.17	3.4229	81.93	3.6914
53.19	2.8906	61.85	3.1592	71.36	3.4277	82.14	3.6963
53.34	2.8955	62.02	3.1641	71.54	3.4326	82.35	3.7012
53.50	2.9004	62.18	3.1689	71.72	3.4375	82.56	3.7061
53.65	2.9053	62.34	3.1738	71.91	3.4424		
53.80	2.9102	62.51	3.1787	72.09	3.4473		
53.95	2.9150	62.67	3.1836	72.28	3.4521		
54.11	2.9199	62.84	3.1885	72.46	3.4570		
54.26	2.9248	63.01	3.1934	72.64	3.4619		
54.41	2.9297	63.17	3.1982	72.83	3.4668		

TABLE 4 — OIL AND DISCHARGE TEMP.

temp(F)	Vin	temp(F)	Vin	temp(F)	Vin	temp(F)	Vin
31.99	0.2637	58.43	0.5322	75.98	0.8008	89.90	1.0693
32.63	0.2686	58.81	0.5371	76.25	0.8057	90.13	1.0742
33.27	0.2734	59.18	0.5420	76.53	0.8105	90.36	1.0791
33.90	0.2783	59.54	0.5469	76.81	0.8154	90.59	1.0840
34.51	0.2832	59.90	0.5518	77.09	0.8203	90.82	1.0889
35.12	0.2881	60.26	0.5566	77.36	0.8252	91.05	1.0938
35.73	0.2930	60.63	0.5615	77.63	0.8301	91.28	1.0986
36.32	0.2979	60.98	0.5664	77.90	0.8350	91.51	1.1035
36.91	0.3027	61.33	0.5713	78.17	0.8398	91.74	1.1084
37.49	0.3076	61.69	0.5762	78.44	0.8447	91.96	1.1133
38.05	0.3125	62.04	0.5811	78.71	0.8496	92.19	1.1182
38.61	0.3174	62.39	0.5859	78.98	0.8545	92.42	1.1230
39.18	0.3223	62.73	0.5908	79.24	0.8594	92.64	1.1279
39.72	0.3271	63.07	0.5957	79.50	0.8643	92.87	1.1328
40.26	0.3320	63.41	0.6006	79.77	0.8691	93.10	1.1377
40.80	0.3369	63.75	0.6055	80.03	0.8740	93.32	1.1426
41.33	0.3418	64.09	0.6104	80.30	0.8789	93.54	1.1475
41.85	0.3467	64.43	0.6152	80.56	0.8838	93.77	1.1523
42.37	0.3516	64.76	0.6201	80.82	0.8887	93.99	1.1572
42.89	0.3564	65.09	0.6250	81.08	0.8936	94.21	1.1621
43.39	0.3613	65.42	0.6299	81.33	0.8984	94.43	1.1670
43.89	0.3662	65.75	0.6348	81.59	0.9033	94.65	1.1719
44.39	0.3711	66.08	0.6396	81.85	0.9082	94.88	1.1768
44.88	0.3760	66.40	0.6445	82.11	0.9131	95.10	1.1816
45.36	0.3809	66.72	0.6494	82.37	0.9180	95.32	1.1865
45.84	0.3857	67.04	0.6543	82.62	0.9229	95.53	1.1914
46.32	0.3906	67.36	0.6592	82.87	0.9277	95.75	1.1963
46.79	0.3955	67.68	0.6641	83.12	0.9326	95.97	1.2012
47.25	0.4004	68.00	0.6689	83.37	0.9375	96.19	1.2061
47.72	0.4053	68.31	0.6738	83.62	0.9424	96.41	1.2109
48.18	0.4102	68.62	0.6787	83.88	0.9473	96.63	1.2158
48.63	0.4150	68.93	0.6836	84.13	0.9521	96.84	1.2207
49.07	0.4199	69.24	0.6885	84.38	0.9570	97.06	1.2256
49.52	0.4248	69.55	0.6934	84.62	0.9619	97.27	1.2305
49.97	0.4297	69.86	0.6982	84.87	0.9668	97.49	1.2354
50.40	0.4346	70.17	0.7031	85.11	0.9717	97.70	1.2402
50.83	0.4395	70.47	0.7080	85.36	0.9766	97.92	1.2451
51.26	0.4443	70.77	0.7129	85.61	0.9814	98.13	1.2500
51.69	0.4492	71.07	0.7178	85.85	0.9863	98.35	1.2549
52.11	0.4541	71.37	0.7227	86.10	0.9912	98.56	1.2598
52.53	0.4590	71.67	0.7275	86.34	0.9961	98.77	1.2646
52.94	0.4639	71.96	0.7324	86.58	1.0010	98.98	1.2695
53.36	0.4688	72.26	0.7373	86.82	1.0059	99.20	1.2744
53.77	0.4736	72.55	0.7422	87.06	1.0107	99.41	1.2793
54.17	0.4785	72.84	0.7471	87.30	1.0156	99.62	1.2842
54.57	0.4834	73.14	0.7520	87.54	1.0205	99.83	1.2891
54.97	0.4883	73.43	0.7568	87.78	1.0254	100.04	1.2939
55.37	0.4932	73.72	0.7617	88.02	1.0303	100.25	1.2988
55.76	0.4980	74.00	0.7666	88.25	1.0352	100.46	1.3037
56.15	0.5029	74.29	0.7715	88.49	1.0400	100.67	1.3086
56.54	0.5078	74.57	0.7764	88.72	1.0449	100.88	1.3135
56.92	0.5127	74.86	0.7813	88.96	1.0498	101.09	1.3184
57.31	0.5176	75.14	0.7861	89.20	1.0547	101.29	1.3232
57.68	0.5225	75.42	0.7910	89.43	1.0596	101.50	1.3281
58.06	0.5273	75.70	0.7959	89.67	1.0645	101.71	1.3330

SECTION
3D

TABLE 4 — OIL AND DISCHARGE TEMP. - (Continued)

temp(F)	Vin	temp(F)	Vin	temp(F)	Vin	temp(F)	Vin	temp(F)	Vin
101.92	1.3379	112.86	1.6064	123.21	1.8750	133.27	2.1436	143.32	2.4121
102.13	1.3428	113.06	1.6113	123.39	1.8799	133.46	2.1484	143.51	2.4170
102.33	1.3477	113.25	1.6162	123.58	1.8848	133.64	2.1533	143.69	2.4219
102.54	1.3525	113.44	1.6211	123.76	1.8896	133.82	2.1582	143.87	2.4268
102.74	1.3574	113.63	1.6260	123.94	1.8945	134.00	2.1631	144.06	2.4316
102.95	1.3623	113.82	1.6309	124.13	1.8994	134.18	2.1680	144.24	2.4365
103.15	1.3672	114.01	1.6357	124.31	1.9043	134.37	2.1729	144.43	2.4414
103.36	1.3721	114.20	1.6406	124.50	1.9092	134.55	2.1777	144.61	2.4463
103.56	1.3770	114.40	1.6455	124.68	1.9141	134.73	2.1826	144.80	2.4512
103.77	1.3818	114.59	1.6504	124.86	1.9189	134.91	2.1875	144.98	2.4561
103.97	1.3867	114.78	1.6553	125.05	1.9238	135.09	2.1924	145.17	2.4609
104.18	1.3916	114.97	1.6602	125.23	1.9287	135.28	2.1973	145.35	2.4658
104.38	1.3965	115.16	1.6650	125.42	1.9336	135.46	2.2021	145.54	2.4707
104.58	1.4014	115.35	1.6699	125.60	1.9385	135.64	2.2070	145.72	2.4756
104.78	1.4063	115.54	1.6748	125.78	1.9434	135.82	2.2119	145.91	2.4805
104.99	1.4111	115.73	1.6797	125.97	1.9482	136.01	2.2168	146.09	2.4854
105.19	1.4160	115.92	1.6846	126.15	1.9531	136.19	2.2217	146.28	2.4902
105.39	1.4209	116.11	1.6895	126.33	1.9580	136.37	2.2266	146.46	2.4951
105.59	1.4258	116.30	1.6943	126.52	1.9629	136.55	2.2314	146.65	2.5000
105.80	1.4307	116.49	1.6992	126.70	1.9678	136.73	2.2363	146.84	2.5049
105.99	1.4355	116.67	1.7041	126.88	1.9727	136.92	2.2412	147.02	2.5098
106.19	1.4404	116.86	1.7090	127.07	1.9775	137.10	2.2461	147.21	2.5146
106.39	1.4453	117.05	1.7139	127.25	1.9824	137.28	2.2510	147.39	2.5195
106.59	1.4502	117.24	1.7188	127.43	1.9873	137.46	2.2559	147.58	2.5244
106.79	1.4551	117.43	1.7236	127.62	1.9922	137.65	2.2607	147.77	2.5293
106.99	1.4600	117.62	1.7285	127.80	1.9971	137.83	2.2656	147.95	2.5342
107.19	1.4648	117.80	1.7334	127.98	2.0020	138.01	2.2705	148.14	2.5391
107.39	1.4697	117.99	1.7383	128.17	2.0068	138.19	2.2754	148.32	2.5439
107.59	1.4746	118.18	1.7432	128.35	2.0117	138.37	2.2803	148.51	2.5488
107.79	1.4795	118.37	1.7480	128.53	2.0166	138.56	2.2852	148.70	2.5537
107.99	1.4844	118.56	1.7529	128.71	2.0215	138.74	2.2900	148.88	2.5586
108.18	1.4893	118.74	1.7578	128.90	2.0264	138.92	2.2949	149.07	2.5635
108.38	1.4941	118.93	1.7627	129.08	2.0313	139.11	2.2998	149.26	2.5684
108.58	1.4990	119.12	1.7676	129.26	2.0361	139.29	2.3047	149.45	2.5732
108.78	1.5039	119.31	1.7725	129.44	2.0410	139.47	2.3096	149.63	2.5781
108.97	1.5088	119.49	1.7773	129.63	2.0459	139.65	2.3145	149.82	2.5830
109.17	1.5137	119.68	1.7822	129.81	2.0508	139.84	2.3193	150.01	2.5879
109.37	1.5186	119.87	1.7871	129.99	2.0557	140.02	2.3242	150.20	2.5928
109.56	1.5234	120.05	1.7920	130.17	2.0605	140.20	2.3291	150.38	2.5977
109.76	1.5283	120.24	1.7969	130.36	2.0654	140.39	2.3340	150.57	2.6025
109.95	1.5332	120.43	1.8018	130.54	2.0703	140.57	2.3389	150.76	2.6074
110.15	1.5381	120.61	1.8066	130.72	2.0752	140.75	2.3438	150.95	2.6123
110.34	1.5430	120.80	1.8115	130.90	2.0801	140.94	2.3486	151.14	2.6172
110.54	1.5479	120.98	1.8164	131.09	2.0850	141.12	2.3535	151.33	2.6221
110.73	1.5527	121.17	1.8213	131.27	2.0898	141.30	2.3584	151.51	2.6270
110.93	1.5576	121.35	1.8262	131.45	2.0947	141.49	2.3633	151.70	2.6318
111.12	1.5625	121.54	1.8311	131.63	2.0996	141.67	2.3682	151.89	2.6367
111.32	1.5674	121.72	1.8359	131.82	2.1045	141.85	2.3730	152.08	2.6416
111.51	1.5723	121.91	1.8408	132.00	2.1094	142.04	2.3779	152.27	2.6465
111.70	1.5771	122.10	1.8457	132.18	2.1143	142.22	2.3828	152.46	2.6514
111.90	1.5820	122.28	1.8506	132.36	2.1191	142.40	2.3877	152.65	2.6563
112.09	1.5869	122.47	1.8555	132.54	2.1240	142.59	2.3926	152.84	2.6611
112.28	1.5918	122.65	1.8604	132.73	2.1289	142.77	2.3975	153.03	2.6660
112.48	1.5967	122.84	1.8652	132.91	2.1338	142.95	2.4023	153.22	2.6709
112.67	1.6016	123.02	1.8701	133.09	2.1387	143.14	2.4072	153.41	2.6758

TABLE 4 — OIL AND DISCHARGE TEMP. (Continued)

temp(F)	Vin	temp(F)	Vin	temp(F)	Vin	temp(F)	Vin	temp(F)	Vin
153.60	2.6807	164.36	2.9492	175.92	3.2178	188.71	3.4863	203.40	3.7549
153.79	2.6855	164.56	2.9541	176.14	3.2227	188.96	3.4912	203.69	3.7598
153.98	2.6904	164.76	2.9590	176.36	3.2275	189.21	3.4961	203.99	3.7646
154.17	2.6953	164.96	2.9639	176.58	3.2324	189.46	3.5010	204.28	3.7695
154.36	2.7002	165.17	2.9688	176.80	3.2373	189.71	3.5059	204.57	3.7744
154.55	2.7051	165.37	2.9736	177.02	3.2422	189.96	3.5107	204.86	3.7793
154.74	2.7100	165.57	2.9785	177.25	3.2471	190.21	3.5156	205.16	3.7842
154.94	2.7148	165.78	2.9834	177.47	3.2520	190.46	3.5205	205.46	3.7891
155.13	2.7197	165.98	2.9883	177.69	3.2568	190.71	3.5254	205.76	3.7939
155.32	2.7246	166.19	2.9932	177.91	3.2617	190.96	3.5303	206.05	3.7988
155.51	2.7295	166.39	2.9980	178.14	3.2666	191.22	3.5352	206.35	3.8037
155.70	2.7344	166.60	3.0029	178.36	3.2715	191.47	3.5400	206.65	3.8086
155.90	2.7393	166.80	3.0078	178.59	3.2764	191.73	3.5449	206.96	3.8135
156.09	2.7441	167.00	3.0127	178.81	3.2813	191.98	3.5498	207.26	3.8184
156.28	2.7490	167.21	3.0176	179.04	3.2861	192.23	3.5547	207.57	3.8232
156.47	2.7539	167.42	3.0225	179.26	3.2910	192.49	3.5596	207.87	3.8281
156.67	2.7588	167.62	3.0273	179.49	3.2959	192.75	3.5645	208.17	3.8330
156.86	2.7637	167.83	3.0322	179.72	3.3008	193.01	3.5693	208.48	3.8379
157.05	2.7686	168.04	3.0371	179.94	3.3057	193.27	3.5742	208.79	3.8428
157.25	2.7734	168.24	3.0420	180.17	3.3105	193.53	3.5791	209.10	3.8477
157.44	2.7783	168.45	3.0469	180.40	3.3154	193.79	3.5840	209.42	3.8525
157.64	2.7832	168.66	3.0518	180.63	3.3203	194.05	3.5889	209.73	3.8574
157.83	2.7881	168.87	3.0566	180.86	3.3252	194.31	3.5938	210.04	3.8623
158.02	2.7930	169.07	3.0615	181.09	3.3301	194.57	3.5986	210.35	3.8672
158.22	2.7979	169.28	3.0664	181.32	3.3350	194.84	3.6035	210.67	3.8721
158.41	2.8027	169.49	3.0713	181.55	3.3398	195.10	3.6084	210.99	3.8770
158.61	2.8076	169.70	3.0762	181.78	3.3447	195.37	3.6133	211.31	3.8818
158.80	2.8125	169.91	3.0811	182.01	3.3496	195.63	3.6182	211.62	3.8867
159.00	2.8174	170.12	3.0859	182.24	3.3545	195.90	3.6230	211.94	3.8916
159.19	2.8223	170.33	3.0908	182.48	3.3594	196.16	3.6279	212.27	3.8965
159.39	2.8271	170.54	3.0957	182.71	3.3643	196.43	3.6328	212.59	3.9014
159.59	2.8320	170.75	3.1006	182.94	3.3691	196.70	3.6377	212.92	3.9063
159.78	2.8369	170.96	3.1055	183.17	3.3740	196.97	3.6426	213.24	3.9111
159.98	2.8418	171.18	3.1104	183.41	3.3789	197.24	3.6475	213.57	3.9160
160.18	2.8467	171.39	3.1152	183.65	3.3838	197.51	3.6523	213.90	3.9209
160.37	2.8516	171.60	3.1201	183.88	3.3887	197.78	3.6572	214.23	3.9258
160.57	2.8564	171.81	3.1250	184.12	3.3936	198.06	3.6621	214.56	3.9307
160.77	2.8613	172.02	3.1299	184.36	3.3984	198.33	3.6670	214.89	3.9355
160.97	2.8662	172.24	3.1348	184.59	3.4033	198.61	3.6719	215.23	3.9404
161.16	2.8711	172.45	3.1396	184.83	3.4082	198.88	3.6768	215.56	3.9453
161.36	2.8760	172.66	3.1445	185.07	3.4131	199.15	3.6816	215.90	3.9502
161.56	2.8809	172.88	3.1494	185.31	3.4180	199.43	3.6865	216.24	3.9551
161.76	2.8857	173.10	3.1543	185.55	3.4229	199.71	3.6914	216.58	3.9600
161.96	2.8906	173.31	3.1592	185.79	3.4277	199.99	3.6963	216.92	3.9648
162.15	2.8955	173.53	3.1641	186.03	3.4326	200.27	3.7012	217.26	3.9697
162.35	2.9004	173.74	3.1689	186.27	3.4375	200.55	3.7061	217.60	3.9746
162.55	2.9053	173.96	3.1738	186.51	3.4424	200.83	3.7109	217.95	3.9795
162.75	2.9102	174.17	3.1787	186.75	3.4473	201.11	3.7158	218.30	3.9844
162.95	2.9150	174.39	3.1836	186.99	3.4521	201.39	3.7207	218.65	3.9893
163.15	2.9199	174.61	3.1885	187.24	3.4570	201.68	3.7256	219.00	3.9941
163.35	2.9248	174.83	3.1934	187.48	3.4619	201.97	3.7305	219.35	3.9990
163.55	2.9297	175.04	3.1982	187.73	3.4668	202.25	3.7354	219.70	4.0039
163.75	2.9346	175.26	3.2031	187.97	3.4717	202.54	3.7402	220.06	4.0088
163.96	2.9395	175.48	3.2080	188.22	3.4766	202.82	3.7451		
164.16	2.9443	175.70	3.2129	188.46	3.4814	203.11	3.7500		

TABLE 5 — ENTERING AND LEAVING CONDENSER WATER

temp(F)	Vin	temp(F)	Vin	temp(F)	Vin	temp(F)	Vin
40.12	1.8408	48.39	2.1094	56.61	2.3779	64.98	2.6465
40.27	1.8457	48.54	2.1143	56.76	2.3828	65.14	2.6514
40.42	1.8506	48.69	2.1191	56.91	2.3877	65.29	2.6563
40.58	1.8555	48.84	2.1240	57.06	2.3926	65.45	2.6611
40.73	1.8604	48.99	2.1289	57.21	2.3975	65.60	2.6660
40.88	1.8652	49.14	2.1338	57.36	2.4023	65.76	2.6709
41.03	1.8701	49.29	2.1387	57.51	2.4072	65.91	2.6758
41.18	1.8750	49.44	2.1436	57.66	2.4121	66.07	2.6807
41.33	1.8799	49.59	2.1484	57.81	2.4170	66.22	2.6855
41.48	1.8848	49.74	2.1533	57.97	2.4219	66.38	2.6904
41.64	1.8896	49.89	2.1582	58.12	2.4268	66.54	2.6953
41.79	1.8945	50.03	2.1631	58.27	2.4316	66.69	2.7002
41.94	1.8994	50.18	2.1680	58.42	2.4365	66.85	2.7051
42.09	1.9043	50.33	2.1729	58.57	2.4414	67.00	2.7100
42.24	1.9092	50.48	2.1777	58.72	2.4463	67.16	2.7148
42.39	1.9141	50.63	2.1826	58.87	2.4512	67.32	2.7197
42.54	1.9189	50.78	2.1875	59.02	2.4561	67.47	2.7246
42.70	1.9238	50.93	2.1924	59.17	2.4609	67.63	2.7295
42.85	1.9287	51.08	2.1973	59.33	2.4658	67.78	2.7344
43.00	1.9336	51.23	2.2021	59.48	2.4707	67.94	2.7393
43.15	1.9385	51.38	2.2070	59.63	2.4756	68.10	2.7441
43.30	1.9434	51.53	2.2119	59.78	2.4805	68.26	2.7490
43.45	1.9482	51.68	2.2168	59.93	2.4854	68.41	2.7539
43.60	1.9531	51.83	2.2217	60.09	2.4902	68.57	2.7588
43.75	1.9580	51.97	2.2266	60.24	2.4951	68.73	2.7637
43.90	1.9629	52.12	2.2314	60.39	2.5000	68.89	2.7686
44.05	1.9678	52.27	2.2363	60.54	2.5049	69.05	2.7734
44.20	1.9727	52.42	2.2412	60.69	2.5098	69.21	2.7783
44.35	1.9775	52.57	2.2461	60.85	2.5146	69.36	2.7832
44.50	1.9824	52.72	2.2510	61.00	2.5195	69.52	2.7881
44.65	1.9873	52.87	2.2559	61.15	2.5244	69.68	2.7930
44.80	1.9922	53.02	2.2607	61.30	2.5293	69.84	2.7979
44.95	1.9971	53.17	2.2656	61.45	2.5342	70.00	2.8027
45.10	2.0020	53.32	2.2705	61.61	2.5391	70.16	2.8076
45.25	2.0068	53.47	2.2754	61.76	2.5439	70.32	2.8125
45.40	2.0117	53.62	2.2803	61.91	2.5488	70.48	2.8174
45.55	2.0166	53.77	2.2852	62.06	2.5537	70.64	2.8223
45.70	2.0215	53.92	2.2900	62.21	2.5586	70.80	2.8271
45.85	2.0264	54.07	2.2949	62.36	2.5635	70.96	2.8320
46.00	2.0313	54.21	2.2998	62.52	2.5684	71.12	2.8369
46.15	2.0361	54.36	2.3047	62.67	2.5732	71.28	2.8418
46.30	2.0410	54.51	2.3096	62.82	2.5781	71.44	2.8467
46.45	2.0459	54.66	2.3145	62.98	2.5830	71.61	2.8516
46.60	2.0508	54.81	2.3193	63.13	2.5879	71.77	2.8564
46.75	2.0557	54.96	2.3242	63.29	2.5928	71.93	2.8613
46.90	2.0605	55.11	2.3291	63.44	2.5977	72.09	2.8662
47.05	2.0654	55.26	2.3340	63.59	2.6025	72.25	2.8711
47.20	2.0703	55.41	2.3389	63.75	2.6074	72.41	2.8760
47.35	2.0752	55.56	2.3438	63.90	2.6123	72.57	2.8809
47.50	2.0801	55.71	2.3486	64.06	2.6172	72.73	2.8857
47.65	2.0850	55.86	2.3535	64.21	2.6221	72.89	2.8906
47.79	2.0898	56.01	2.3584	64.36	2.6270	73.05	2.8955
47.94	2.0947	56.16	2.3633	64.52	2.6318	73.22	2.9004
48.09	2.0996	56.31	2.3682	64.67	2.6367	73.38	2.9053
48.24	2.1045	56.46	2.3730	64.83	2.6416	73.54	2.9102

TABLE 5 — ENTERING AND LEAVING CONDENSER WATER (Continued)

temp(F)	Vin	temp(F)	Vin	temp(F)	Vin	temp(F)	Vin
73.71	2.9150	83.04	3.1836	93.31	3.4521	105.04	3.7207
73.87	2.9199	83.22	3.1885	93.51	3.4570	105.27	3.7256
74.04	2.9248	83.39	3.1934	93.70	3.4619	105.50	3.7305
74.20	2.9297	83.57	3.1982	93.90	3.4668	105.73	3.7354
74.37	2.9346	83.75	3.2031	94.10	3.4717	105.96	3.7402
74.53	2.9395	83.93	3.2080	94.30	3.4766	106.20	3.7451
74.70	2.9443	84.10	3.2129	94.50	3.4814	106.44	3.7500
74.86	2.9492	84.28	3.2178	94.70	3.4863	106.67	3.7549
75.03	2.9541	84.46	3.2227	94.90	3.4912	106.91	3.7598
75.19	2.9590	84.65	3.2275	95.11	3.4961	107.14	3.7646
75.36	2.9639	84.83	3.2324	95.31	3.5010	107.38	3.7695
75.52	2.9688	85.01	3.2373	95.52	3.5059	107.62	3.7744
75.69	2.9736	85.19	3.2422	95.72	3.5107	107.86	3.7793
75.85	2.9785	85.37	3.2471	95.93	3.5156	108.11	3.7842
76.02	2.9834	85.55	3.2520	96.13	3.5205	108.35	3.7891
76.19	2.9883	85.73	3.2568	96.34	3.5254	108.59	3.7939
76.35	2.9932	85.92	3.2617	96.54	3.5303	108.84	3.7988
76.52	2.9980	86.10	3.2666	96.75	3.5352	109.08	3.8037
76.69	3.0029	86.28	3.2715	96.96	3.5400	109.32	3.8086
76.85	3.0078	86.47	3.2764	97.17	3.5449	109.57	3.8135
77.02	3.0127	86.65	3.2813	97.38	3.5498	109.82	3.8184
77.19	3.0176	86.84	3.2861	97.59	3.5547	110.06	3.8232
77.36	3.0225	87.02	3.2910	97.80	3.5596	110.31	3.8281
77.53	3.0273	87.21	3.2959	98.01	3.5645	110.56	3.8330
77.70	3.0322	87.39	3.3008	98.22	3.5693	110.81	3.8379
77.86	3.0371	87.58	3.3057	98.43	3.5742	111.05	3.8428
78.03	3.0420	87.76	3.3105	98.64	3.5791	111.31	3.8477
78.20	3.0469	87.95	3.3154	98.86	3.5840	111.56	3.8525
78.37	3.0518	88.13	3.3203	99.07	3.5889	111.82	3.8574
78.54	3.0566	88.32	3.3252	99.29	3.5938	112.08	3.8623
78.71	3.0615	88.51	3.3301	99.50	3.5986	112.34	3.8672
78.88	3.0664	88.70	3.3350	99.71	3.6035	112.59	3.8721
79.05	3.0713	88.88	3.3398	99.93	3.6084	112.85	3.8770
79.22	3.0762	89.07	3.3447	100.14	3.6133	113.11	3.8818
79.40	3.0811	89.26	3.3496	100.36	3.6182	113.37	3.8867
79.57	3.0859	89.44	3.3545	100.58	3.6230	113.63	3.8916
79.74	3.0908	89.63	3.3594	100.79	3.6279	113.88	3.8965
79.91	3.0957	89.82	3.3643	101.01	3.6328	114.14	3.9014
80.08	3.1006	90.01	3.3691	101.23	3.6377		
80.26	3.1055	90.20	3.3740	101.45	3.6426		
80.43	3.1104	90.39	3.3789	101.67	3.6475		
80.60	3.1152	90.59	3.3838	101.89	3.6523		
80.77	3.1201	90.78	3.3887	102.11	3.6572		
80.95	3.1250	90.97	3.3936	102.33	3.6621		
81.12	3.1299	91.16	3.3984	102.55	3.6670		
81.29	3.1348	91.35	3.4033	102.78	3.6719		
81.47	3.1396	91.54	3.4082	103.00	3.6768		
81.64	3.1445	91.74	3.4131	103.22	3.6816		
81.81	3.1494	91.93	3.4180	103.45	3.6865		
81.99	3.1543	92.13	3.4229	103.67	3.6914		
82.16	3.1592	92.32	3.4277	103.89	3.6963		
82.33	3.1641	92.52	3.4326	104.12	3.7012		
82.51	3.1689	92.72	3.4375	104.35	3.7061		
82.69	3.1738	92.91	3.4424	104.58	3.7109		
82.86	3.1787	93.11	3.4473	104.81	3.7158		

SECTION 3E DISPLAY (REF. FIG. 36, 37 & 38)

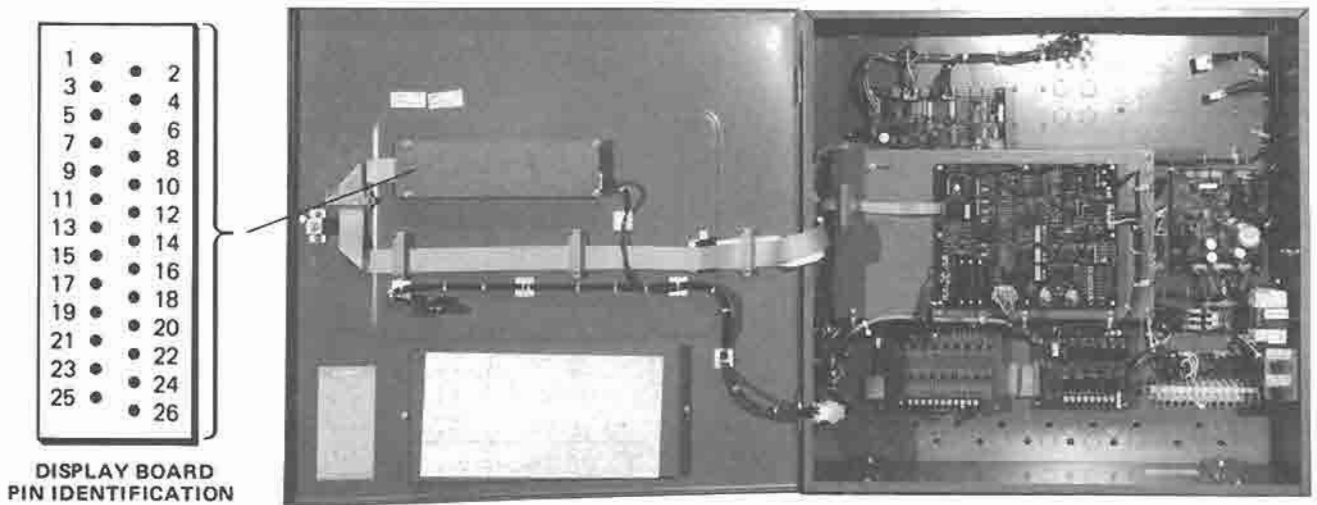

24670
FIG. 36 — CONTROL CENTER DISPLAY BOARD

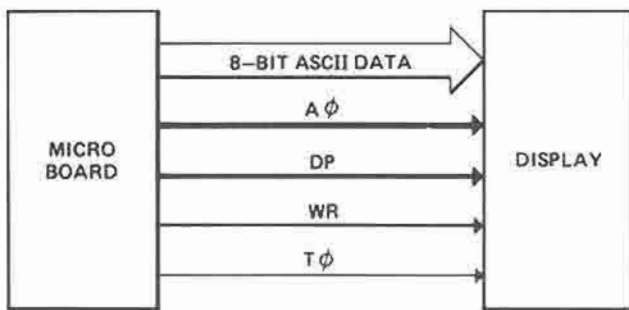

**FIG. 37 — VACUUM FLUORESCENT DISPLAY
BLOCK DIAGRAM**

The Control Center Display P/N 031-00775-001 (Babcock VF-140-02 or IEE 33383-01) is a 40 character vacuum fluorescent dot matrix display. It receives a parallel 8-bit ASCII alphanumeric word from the Micro Board. Each 8-bit word represents a character.

When the Micro Board writes to the display, it provides the 8-bit ASCII word along with a **WR** pulse and the **DP** (chip select pulse). The least significant bit (LSB) of the

address bus, **A0**, must also be driven low to allow the display to accept data from the Micro Board.

In addition to the alphanumeric data that is written to the display, command codes are also written to the display. These codes control the position of the cursor. When the Micro Board writes a command code to the display it provides the code along with a **WR** and **DP** pulse. Also, the LSB of the address bus must be driven high to allow the display to accept a command code.

Each character is displayed on a 5 x 7 phosphor dot matrix (Fig. 38). A character generator interprets the ASCII word and illuminates the appropriate dots in the matrix to form the alphanumeric character.

The power supply board (031-01080) contains a reset circuit that resets the display during low voltage conditions. Whenever the +5VDC regulated supply voltage to the display decreases to 4.7VDC, the power supply drives the **RESET** input (J1-6) from +5VDC to a logic low condition less than 1VDC. This causes the display to blank for the duration of the condition.

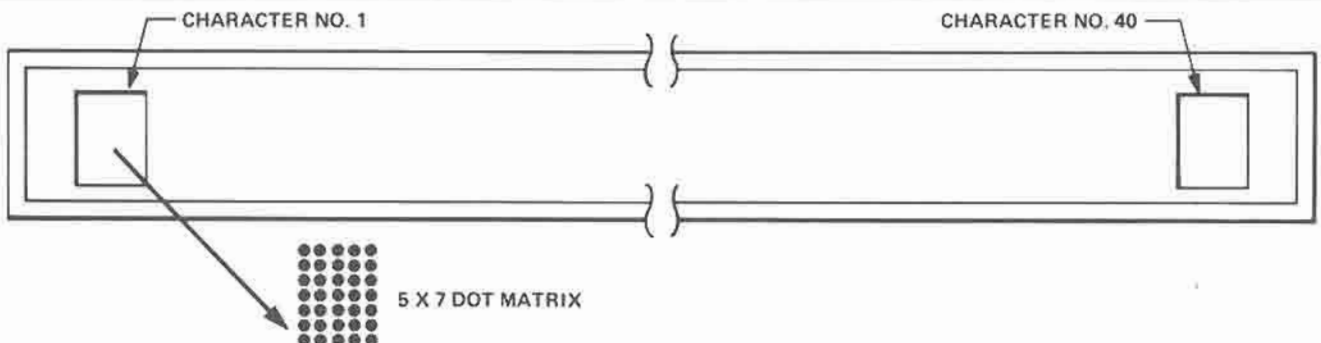
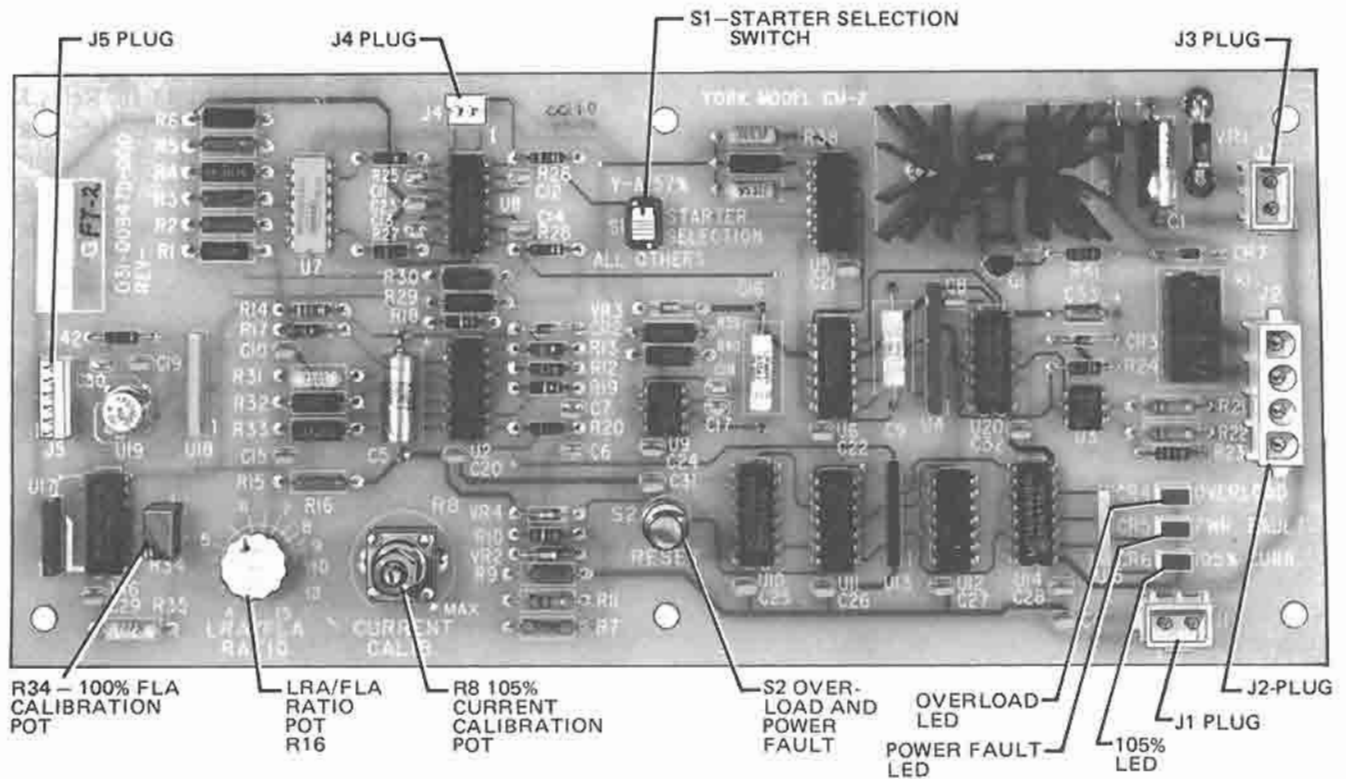

FIG. 38 — VACUUM FLUORESCENT DISPLAY

SECTION 3F
CM-2 CURRENT MODULE
FOR ELECTRO-MECHANICAL STARTER APPLICATIONS ONLY
 (Ref. Fig. 39 & 40)



24244

FIG. 39 - CM-2 CURRENT MODULE

If the MicroComputer Control Center is used with an electro-mechanical starter, a CM-2 module is required. It is mounted on the hinged door inside the Control Center. This module provides compressor motor current **OVERLOAD** and **POWER FAULT** protection. Also, the 100% FLA motor current signal is calibrated on this board and multiplexed to the Micro Board for use in current limit control and display purposes.

External to the CM-2, three CT's provide 30 motor current signal to a diode bridge. The bridge rectifies the signal and applies it to two parallel variable resistors. The resistors are adjusted to provide a 1VDC (.90-1.05VDC) signal to the CM-2 (J1-1/2) when the compressor motor is conducting 100% FLA. On the CM-2 module, this signal is applied to a power fault detector circuit. When the motor current decreases to 15% FLA the power fault detector initiates a 1 second pulse from the monopulse circuit and simultaneously illuminates the "Power Fault" LED. The LED remains illuminated until manually reset. The 1 second pulse de-energizes K1 relay for 1 second. After 1 second, K1 relay again energizes. This causes a momentary interruption of the "Motor Controller Circuit" located between TB5-53, TB3-16 and Digital Input Board J2-1 and initiates a chiller shutdown. **MON**

XX.XX AM POWER FAULT AUTOSTART is displayed on the keypad display. At the completion of "System Coastdown" the chiller will automatically restart. The power fault detector is inhibited for 75 seconds after the 120VAC start signal **24** is received.

The motor current signal input at J1-2 and J1-1 is also buffered and applied to the 100% FLA calibration potentiometer (R34). The wiper of the POT provides an analog voltage to the multiplexer (MUX). This voltage represents the compressor motor current. The POT is calibrated to provide 4VDC @ 100% FLA. When the Micro Board addresses MUX Channel No. 0, 0VDC is output from the MUX to the Micro Board. This tells the Micro Board that this is an electro-mechanical starter application and the Micro Board skips over MUX Channel 1 thru 6 and addresses MUX Channel No. 7. The motor current analog signal is then output to the micro board where this value is used to determine when "Current Limit" control is to be initiated. Also this value can be displayed as "% FLA" upon operator request.

The buffered motor current signal is also applied to the motor current "Overload" circuits. When the motor current reaches 105% FLA the 105% FLA LED illuminates

and the 50 second timer is started. When 50 seconds have elapsed, if the current is still at 105% FLA, the timer output causes the latching circuit to latch and illuminate the "OVERLOAD" LED. Simultaneously, K1 relay is de-energized. This opens the "Motor Controller" circuit between Micro Control Center TB5-53, TB3-16 and Digital Input Board J2-1 which initiates a chiller shutdown. **MON XX XX AM MOTOR CONTROLLER-EXT** **RESET** is displayed on the keypad display. The "OVERLOAD" LED remains illuminated and K1 relay remains de-energized until the **RESET** pushbutton is pressed.

The remaining overload circuits (245% FLA, 290% FLA, 360% FLA) receive the buffered motor current signal from the **LRA/FLA RATIO** potentiometer. The setting of this POT is determined by $\frac{LRA}{FLA} = \text{SETTING}$. If switch S1 is in **ALL OTHERS** (across the line starter) position, when the motor current remains at 245% FLA, 290% FLA, or 360% FLA for 40 seconds, 20 seconds or 10 seconds respectively, the chiller shuts down on "OVERLOAD" as described above. If switch S1 is in the **YΔ/57%** (YΔ = open/close transition starter; 57% = auto-transformer starter) the 245% FLA detection circuit is disabled.

CM-2 MODULE - INPUTS AND OUTPUTS

J1-1/2—3Ø motor current input. Calibrated by external variable resistors to be 1VDC @ 100% FLA (.90—1.05VDC).

J2-1/2—Dry closure relay (K1) contacts interfaced to the "Motor Controller" circuit TB5-53 to Relay Output Board TB3-16 and digital input board TB3-16. Relay K1 is normally energized causing contacts to be closed. When CM-2 module initiates a **POWER FAULT** shutdown, contacts open for 1 second and then close. When CM-2 module initiates an **OVERLOAD** shutdown, contacts open and remain open until manually reset with S2 **RESET** pushbutton.

J2-3/4—120VAC start signal input from TB5-24. Signal is used to inhibit power fault detection circuit for the first 75 seconds of chiller run time.

J3-1—30VDC Return (GND.)

J3-2—+ 30VDC unregulated from power supply board.

J5-1—2² address bit from Micro Board. +15VDC in active state. Otherwise 0VDC.

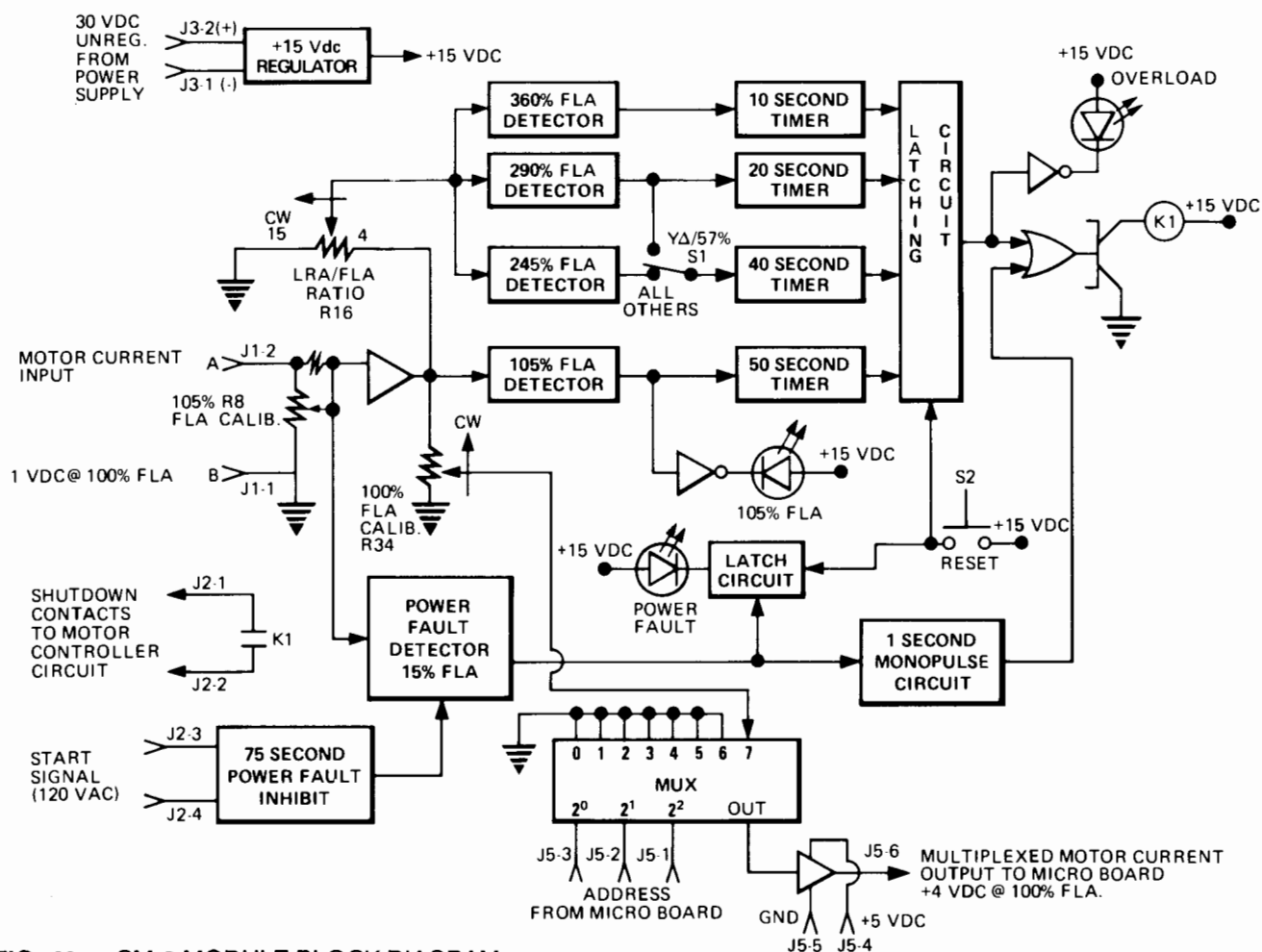

FIG. 40 — CM-2 MODULE BLOCK DIAGRAM

J5-2—2¹ address bit from Micro Board. +15VDC in active state. Otherwise 0VDC.

J5-3—2⁰ address bit from Micro Board. +15VDC in active state. Otherwise 0VDC.

J5-4— +5VDC from Micro Board.

J5-5— +5VDC Return (GND.) from Micro Board.

J5-6— Multiplexed 0-5VDC output of MUX to Micro Board.

ADDRESS

000
001
010
011
100
101
110
111

OUTPUT

0VDC (GND)
Not Used
Not Used
Not Used
Not Used
Not Used
Not Used
0-5VDC motor current analog signal calibrated on CM-2 module to be +4VDC @ 100% FLA

**SECTION 3G
REMOTE CURRENT LIMIT/LCWT SETPOINT BOARD**

(Ref. Fig. 41 & 43)

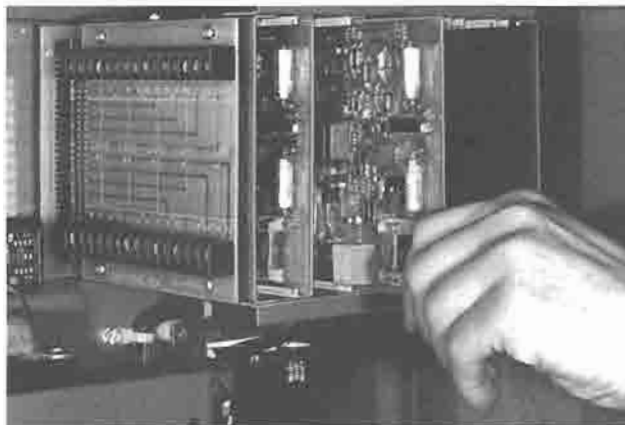

BOARD CARD FILE

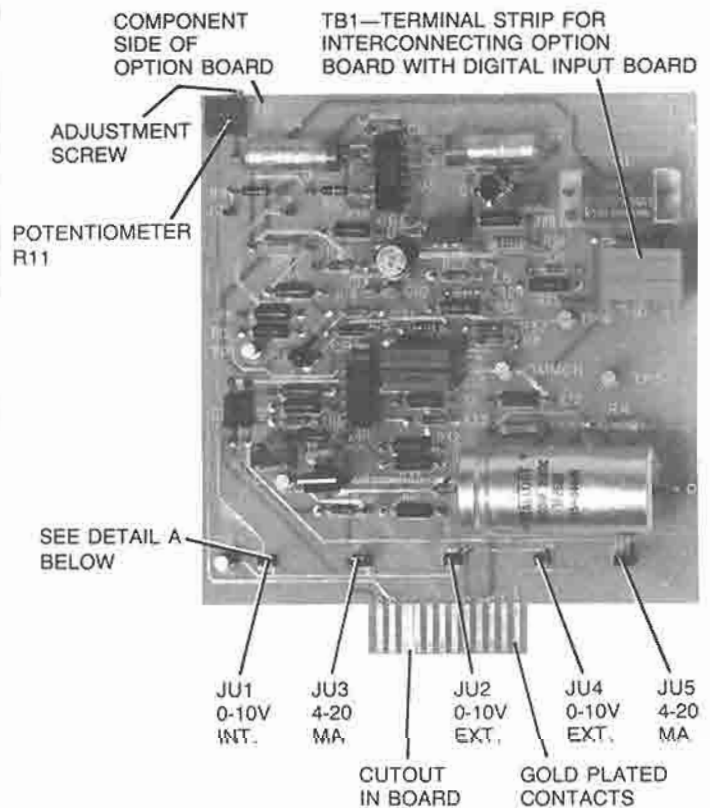

TERMINAL STRIPS USED TO CONNECT THE OPTION BOARD AND THE CARD FILE TO EXTERNAL CONTROL SIGNALS.

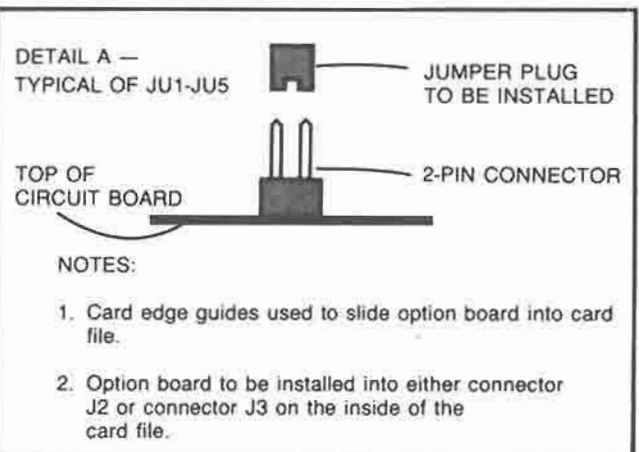

22647 22646 22681

FIG. 41 — CARD FILE AND BOARDS

SECTION 3F
SECTION 3G

The Remote Current Limit/LCWT Setpoint Board(s) (031-00814-000) allows the MicroComputer Control Center to accept a 4-20MA, 0-10VDC or a contact closure remote setpoint from an Energy Management System (EMS). This board(s) slides into a card file (031-00827-000) that is field mounted in the upper right corner of the MicroComputer Control Center enclosure. Both the card file and the PC board(s) are Customer options. (For connection to energy management systems).

This board can accept either remote current limit setpoints or remote LCWT setpoints from an EMS. Therefore, if both of these remote setpoint capabilities are desired, two boards (031-00814-000) are required. They are installed in J2 and J3 of the card file. (If only one function is required, the board is installed in J2 or J3).

The EMS (supplied by others) applies a 4-20MA or 0-10VDC or contact closure to the remote current limit/LCWT setpoint board. This board converts the remote signal to Pulse Width Modulation (PWM). The PWM pulse is applied to the appropriate input (TB2-19 for LCWT or TB2-20 for current limit) of the digital input board where the 115VAC PWM pulse is converted to +15VDC PWM pulse for use by the Micro Board. The length of the PWM pulse is 1-11 seconds. Refer to "Inputs & Outputs" section in this book for details of these signals. The board contains five 2-Pin connectors

(JU1 thru JU5) that are used to configure the board for the desired input signal type. Two 2-pin jumper plugs are provided with each board. These jumper plugs are installed on the 2-pin connectors as follows:

<u>DESIRED INPUT</u>	<u>INSTALL JUMPERS ON:</u>
4-20 MA	JU5 & JU3
0-10VDC	JU4 & JU2
Contact Closure	JU1 & JU4

The **0-10VDC Customer Input** is applied to the board @ J1-12 and passes thru JU4 and JU2 to amplifier no. 1 where it is conditioned for input to the analog to PWM converter. The 80 second interval timer assures a PWM pulse is only output at a rate of 1 pulse every 80 seconds. The Micro Board ignores pulses received at less than 60 second intervals. The PWM output drives relay K1 which is normally de-energized. When the PWM pulse is output, relay K1 is energized for a period of 1-11 seconds. This applies 115VAC to the digital input board for a period of 1-11 seconds. When the contacts open, 0VAC is applied to the digital input board.

The **4-20MA Customer Input** is applied at J1-12 and passes thru JU5 to the "Current To Voltage Converter" where the 4-20MA signal is converted to a 0-10VDC signal. This signal passes thru JU3 and then continues on the same path as discussed above.

FIG. 42 – REMOTE CURRENT LIMIT/REMOTE LCWT SETPOINT CONFIGURATION

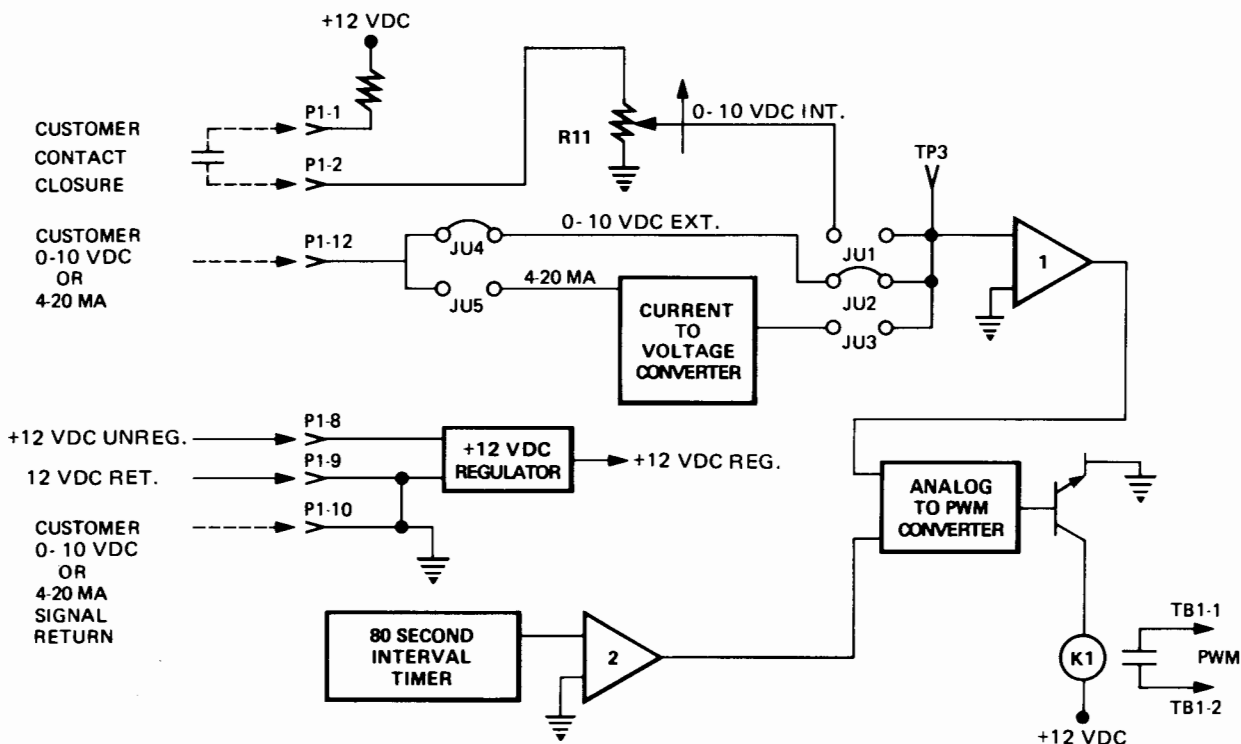

FIG. 43 – REMOTE CURRENT LIMIT/REMOTE LCWT SETPOINT BOARD SIMPLIFIED BLOCK DIAGRAM
PART NO. 031-00814-00

The “Contact Closure Customer Input” is applied at J1-1 & J1-2. When the contacts are open, 0VDC is applied to JU1. When the contacts are closed, a voltage (0-10VDC) corresponding to the setting of POT R11 is applied to JU1. This signal passes thru JU1 and continues on the same path as discussed above.

REMOTE CURRENT LIMIT/LCWT SETPOINT BOARD (031-00814-000) – INPUTS

Since this board is installed in the card file, the field supplied 4-20MA, 0-10VDC or contact closure inputs to this board connect to the card file. The field connection terminal strips are located on the left side of the card file. When the board is installed in the card file, all inputs are automatically connected to the board from the card file.

When a board is installed in J2 of the card file, the input connections are:

INPUT		CARD FILE TERMINAL
4-2MA	(+)	28
4-20MA	(-)	30
0-10VDC	(+)	28
0-10VDC	(-)	30
Contact Closure		25 & 26

When a board is installed in J3 of the card file, the input connections are:

INPUT		CARD FILE TERMINAL
4-20MA	(+)	22
4-20MA	(-)	24
0-10VDC	(+)	22
0-10VDC	(-)	24
Contact Closure		19 & 20

When this board is used for remote current limit setpoint, the following is an analysis of the input signals:

4-20MA - 4-20MA input corresponding to a 100% - 40% current limit setpoint (i.e., 4MA = 100% setpoint, 20MA = 40%). To calculate the setpoint for values between 4MA and 20MA use the following formula:

$$\text{SETPOINT} = 100\% - [(\text{MA SIGNAL} - 4) 3.75\%]$$

For example, an 8MA input would be calculated as follows:

$$\begin{aligned} \text{SETPOINT} &= 100 - [(8 - 4) 3.75] \\ \text{SETPOINT} &= 100 - [4 \times 3.75] \\ \text{SETPOINT} &= 100 - [15] \\ \text{SETPOINT} &= 85\% \end{aligned}$$

0-10VDC - 0-10VDC input corresponding to a 100%-40% current limit setpoint (i.e., 0VDC = 100% setpoint, 10VDC = 40% setpoint). To calculate the set-

point for values between 0VDC and 10VDC use the following formula:

$$\text{SETPPOINT} = 100\% - [(\text{DC VOLTAGE SIGNAL}) 6\%]$$

For example, a 4VDC input would be calculated as follows:

$$\begin{aligned}\text{SETPPOINT} &= 100 - (4 \times 6) \\ \text{SETPPOINT} &= 100 - 24 \\ \text{SETPPOINT} &= 76\%\end{aligned}$$

CONTACT CLOSURE - When the customer supplied contacts are open, the input is 0VDC which corresponds to a 100% setpoint. When the contacts are closed, the input is 0-10VDC (100% - 40%) as determined by the setting of POT R11 (located on the front edge of the PC Board). To calculate the setpoint for values between 0VDC and 10VDC (as measured @ TP-3) use the above formula.

When this board is used for remote LCWT setpoint, the following is an analysis of the input signals:

4-20MA - A 4MA input corresponds to the control panel operator programmed "Chilled Liquid Temp" setpoint (0°F offset). A 20MA input corresponds to the maximum allowable "Chilled Liquid Temp" setpoint offset (10°F or 20°F as programmed). To calculate the setpoint for values between 4MA and 20MA use the following formula:

$$\begin{aligned}\text{°F OFFSET} &= \frac{(\text{MA SIGNAL} - 4) (\text{REMOTE RESET TEMP RANGE})}{16} \\ \text{SETPPOINT} &= \text{KEYPAD ENTERED SETPOINT} + \text{°F OFFSET}\end{aligned}$$

For example, if the programmed "Remote Reset Temp" range is 10°F and the programmed "Chilled Liquid Temp" is 45°F, a 12MA input would be calculated as follows:

$$\begin{aligned}\text{°F OFFSET} &= \frac{(12 - 4)(10)}{16} = 5\text{°F} \\ \text{SETPPOINT} &= 45 + 5 = 50\text{°F}\end{aligned}$$

0-10VDC - A 0VDC input corresponds to the control panel operator programmed "Chilled Liquid Temp" setpoint (0°F offset). A 10VDC input corresponds to the maximum allowable "Chilled Liquid Temp" setpoint offset (10°F or 20°F as programmed). To calculate the setpoint for values between 0VDC and 10VDC use the following formula:

$$\begin{aligned}\text{°F OFFSET} &= \frac{(\text{DC VOLTAGE SIGNAL}) (\text{REMOTE RESET TEMP RANGE})}{10} \\ \text{SETPPOINT} &= \text{KEYPAD ENTERED SETPOINT} + \text{°F OFFSET}\end{aligned}$$

For example, if the programmed "Remote Reset Temp" range is 10°F and the programmed "Chilled Liquid Temp" is 45°F, a 5VDC input would be calculated as follows:

$$\begin{aligned}\text{°F OFFSET} &= \frac{(5) (10)}{10} = 5\text{°F} \\ \text{SETPPOINT} &= 45 + 5 = 50\text{°F}\end{aligned}$$

CONTACT CLOSURE = When the customer supplied contacts are open, the input is 0VDC which corresponds

to the control panel operator programmed "Chilled Liquid Temp" setpoint (0°F offset). When the contacts are closed the input is 0-10VDC as determined by the setting of POT R11 (located on the front edge of the PC board). A 10VDC input corresponds to the maximum allowable "Chilled Liquid Temp" setpoint offset (10°F or 20°F as programmed). To calculate the setpoint for values between 0VDC and 10VDC (as measured @ TP-3) use the above formula.

REMOTE CURRENT LIMIT/LCWT SETPOINT BOARD (031-00814-000) - OUTPUTS

When this board is used for remote current limit setpoint, the output is as follows:

TB1-1/2 - A relay contact closure Pulse Width Modulated (PWM) signal that is 1-11 seconds in length. A 1 second closure corresponds to a setting of 100% FLA. An 11 second closure corresponds to a setting of 40% FLA. All settings between 1 second and 11 seconds are linearly scaled. To calculate the setpoint for values between 1 second and 11 seconds use the following formula:

$$\text{SETPPOINT} = 100\% [(\text{PULSEWIDTH} - 1)6\%]$$

For example, a 4 second closure would be calculated as follows:

$$\begin{aligned}\text{SETPPOINT} &= 100 - [(4-1) 6] \\ \text{SETPPOINT} &= 100 - 18 \\ \text{SETPPOINT} &= 82\%\end{aligned}$$

When this board is used for remote LCWT setpoint, the output is as follows:

TB1-1/2 - A relay contact closure Pulse Width Modulation (PWM) signal that is 1-11 seconds in length. A 1 second closure corresponds to the control panel operator programmed "Chilled Liquid Temp" setpoint (0°F offset). An 11 second closure corresponds to the maximum allowable "Remote Reset Temp Range" value (10°F or 20°F). Refer to description of "Remote Reset Temp Range". All setting between 1 second and 11 seconds are linearly scaled. To calculate the setpoint for values between 1 second and 11 seconds use the following formulas:

$$\begin{aligned}\text{°F OFFSET} &= \frac{(\text{PULSEWIDTH} - 1) (\text{REMOTE RESET TEMP RANGE})}{10} \\ \text{SETPPOINT} &= \text{KEYPAD ENTERED SETPOINT} + \text{°F OFFSET}\end{aligned}$$

For example, if the programmed "Remote Reset Temp Range" is 10°F and the programmed "Chilled Liquid Temp" is 45°F, a 5 second closure would be calculated as follows:

$$\text{°F OFFSET} = \frac{(5 - 1) (10)}{10}$$

$$\text{°F OFFSET} = \frac{(4) (10)}{10}$$

$$\text{°F OFFSET} = \frac{40}{10}$$

$$\text{°F OFFSET} = 4\text{°F}$$

$$\text{SETPPOINT} = 45\text{°F} + 4\text{°F}$$

$$\text{SETPPOINT} = 49\text{°F}$$

SECTION 3H

HIGH SPEED THRUST COLLAR POSITION AND DRAIN LINE TEMPERATURE SENSOR MODULE

OVERVIEW

The INDIKON Model 4800 Proximity and Temperature Sensor Module is used to sense:

1. the distance between the proximity sensor probe and the high speed thrust collar and
2. the temperature of the high speed drain line.

The module outputs an analog value for each parameter to the Micro Board. If either parameter exceeds the safety threshold, a safety shutdown is initiated and the chiller cannot be restarted until the high speed thrust bearing inspection is performed and a special reset procedure is performed by a YORK service technician.

When the **PROXIMITY SENSOR** and probe are installed, the reference position (REF POS) is established. It is the distance between the proximity sensor probe and the high speed thrust collar. Any distance between 37 and 79 mils is acceptable. This value is entered at the keypad as the "REF POS", using the calibration procedure in **SECTION 4** of this book. This value remains the reference position until the compressor is rebuilt or until field replacement of proximity sensor module and probe. Field replacement of the Micro Board or RTC chip (U16) requires that the "REF POS" value be re-entered at the keypad. The calibration procedure is performed at the YORK factory after the chiller is built, or in the field after the proximity sensor and bearing are retrofit to an existing chiller, or if the proximity sensor module and probe are replaced. After the "REF POS" is established, if this distance increases 10 mils or decreases 20 mils (if the "REF POS" is <42 mils, the minimum allowed distance is 22 mils) from the "REF POS", a safety shutdown is initiated and **DAY-TIME-PROX SENSOR SAFETY SHUTDOWN** is displayed. A special reset procedure, as detailed in **SECTION 4** of this book, is required to restart the chiller after the high speed thrust bearing inspection has been performed. The actual distance between the probe and the high speed thrust collar, along with the reference position can be viewed at any time by pressing the **DISPLAY DATA** key. One of the scrolled messages is **ACTUAL POS=XX MILS;REF POS= YY MILS**

If the temperature of the **HIGH SPEED DRAIN LINE** reaches 250.0°F, a safety shutdown is initiated and **DAY-TIME-HIGH SPEED DRAIN TEMP** is displayed. The chiller cannot be restarted until the high speed thrust bearing inspection is performed and the special reset procedure, as detailed in **SECTION 4** of this book, is performed. The drain line temperature must be equal to or less than 179.0°F to allow a chiller start. The actual high speed drain temperature can be viewed at any time by pressing the **DISPLAY DATA** key. One of the scrolled messages is **HIGH SPEED DRAIN TEMP = XXX.X°F**. If the thermocouple or temperature wiring between the module and micro board become disconnected, a safety shutdown occurs and **DAY-TIME-OPEN DRAIN TEMP THERMOCOUPLE** is displayed. A bearing inspection is not required but the special reset procedure, detailed in **SECTION 4** of this book must be performed.

The INDIKON Model 4800 Proximity and Temp Sensor Module is powered by the MicroComputer Control Center +24VDC power supply. The module becomes unstable when the supply decreases to approximately +17VDC (approx. 74VAC). This will occur before the MicroComputer Control Center shuts down on "POWER FAILURE" (approx. 50VAC). Therefore, to prevent invalid safety shutdowns requiring bearing inspection, the Micro Board monitors the +24VDC supply. When it decreases to +19.0VDC (approx. 76VAC), a cycling shutdown is initiated and **DAY-TIME-DC UNDERVOLTAGE** is displayed. The chiller will automatically restart when this voltage increases to +19.7VDC (approx. 83VAC).

SERVICE REPLACEMENT

The INDIKON 4800 Sensor Module and Proximity Probe are supplied as a matched pair. Therefore, if one fails, they must both be replaced with another matched pair.

SECTION 4

SYSTEM CALIBRATION, SPECIAL SETPOINTS & RESET PROCEDURES

In the following Electro-Mechanical Starter and Liquid Cooled Solid State Starter applications calibration checks and procedures, it will be necessary to manually operate the pre-rotation vanes to achieve the desired motor current. When the pre-rotation vanes **OPEN** key is first pressed in **SERVICE** operating mode, a 10 minute window is opened in which the Micro Board software will allow the motor current to be increased to a maximum of 107% FLA. When 10 minutes have elapsed, the software will automatically impose current limit at 100% FLA thereafter. Upon completion, always return to **LOCAL** or **REMOTE** mode.

ELECTRO-MECHANICAL STARTER APPLICATIONS:

The MicroComputer Control Center is delivered from the factory fully calibrated. However, the calibration must be checked at start-up. If the CM-2 module is replaced, the calibration of the CM-2 module must be checked.

Check calibration as follows:

1. Run chiller. Read compressor motor current in ØA or ØB or ØC with clamp-on ammeter. Apply ammeter to highest phase.
2. Manually operate vanes if necessary and run compressor motor to 100% FLA as indicated by the clamp-on ammeter.
3. With the motor running at 100% FLA, press **100% MOTOR CURRENT** display key on keypad. **MOTOR CURRENT = 100% FLA** should be displayed.
4. Run compressor motor to 105% FLA as indicated by the clamp-on ammeter. The 105% FLA LED on the CM-2 module should illuminate.
5. If system doesn't operate as above, calibration is necessary.

To calibrate, proceed as follows:

1. Calculate $\frac{LRA}{FLA}$ ratio.

LRA = Compressor Motor Locked Rotor Amps.
FLA = Job Full Load Amps.

On CM-2 Module, set switch **R16** (LRA/FLA Ratio) to this value.

2. On CM-2 Module, set switch S1 (Starter Selection) to correct position. UP = Y Δ / 57% (Wye-Delta or Auto-Transformer) starter. Down = All other (Across-The-Line) starters.

3. Program **% Current Limit** to "100% FLA." Program **Pull Down Demand** setpoint to "000 minutes @ 100% FLA."
4. Apply clamp-on ammeter to highest phase of compressor motor current wires (ØA, ØB, or ØC).
5. If necessary, manually operate the vanes and run compressor motor to 100% FLA as indicated by the clamp-on ammeter.
6. Connect digital voltmeter to CM-2 module J1-2 (+) to J1-1 (-).
7. With the compressor motor running @ 100% FLA, the Digital Voltmeter should read 1 VDC (.90 VDC - 1.05 VDC). This is the voltage drop across the "RES" variable resistors.
8. If the voltage drop across the "RES" variable resistors is not correct, they must be adjusted. Use the formulas below to calculate the correct resistance. Then adjust both resistors equally such that the combined resistance equals the calculated value.

Motor Voltage	FLA	CT Ratio	Resistance
208-600	65-111	200:1	$R = \frac{1.282 \text{ (CT Ratio)}}{\text{FLA}}$
	112-224	350:1	
	225-829	700:1	
	830-1790	1400:1	
2300-4160	11-18	200:1	$R = \frac{0.247 \text{ (CT Ratio)}}{\text{FLA}}$
	19-37	200:1	
	38-123	200:1	
	124-264	350:1	

NOTE: This completes the recommended field calibration. Field calibration of the CM-2 module is not practical and not recommended. Although the following procedure can be used for field calibrations of the CM-2, nuisance "Overload" or "Power Fault" shut-downs can occur during the procedure.

1. Manually operate the vanes to run the compressor motor @ 105% FLA. (As indicated by clamp-on ammeter on highest phase).
2. Adjust POT **R8** on CM-2 module until "105%" LED just illuminates.
3. Manually operate the vanes to run the compressor motor @ 100% FLA (as indicated by clamp-on ammeter on highest phase).

- Monitor Keypad % **MOTOR CURRENT** key and adjust CM-2 module POT **R34** until Keypad display reads

MOTOR CURRENT = 100% FLA

LIQUID COOLED SOLID STATE STARTER APPLICATIONS:

The AC power line **supply voltage range** and chiller **full load amps** value must be checked at the control center keypad at system start-up. If the proper supply voltage range is not programmed, the control center will shutdown on "Low Line Voltage." If the proper full load amps are not programmed, current limit control will not occur at the proper current levels. For security reasons, a special access code is required to program these setpoints. To prevent unauthorized personnel from changing these setpoints, this access code does not appear in any other published document. Refer to the programming procedure below.

The LCSSS Logic Board **start current** and **overload POTS** are calibrated as delivered from the factory. However, they must be checked at system start-up. If the LCSSS Logic Board is field replaced, field calibration is necessary. Refer to procedure below.

Programming the Undervoltage and Chiller Full Load Amps (FLA) Setpoints (Solid State Starter Applications Only):

- Press **Access Code** key.
- ENTER VALID ACCESS CODE** is displayed.
- Using entry keys enter **1 3 8 0**.
- As each digit is entered, the characters **Y O R K** are displayed.

NOTE: If digits other than **1 3 8 0** are entered, **Y O R K** is still displayed.

- Press **ENTER** key.

NOTE: If digits other than **1 3 8 0** were entered in Step No. 4, **INVALID ACCESS CODE** is displayed when the **ENTER** key is pressed. If this occurs, enter the correct access code (1380) and proceed.

- ACCESS TO PROGRAM KEY AUTHORIZED** is displayed.

NOTE: Unless terminated by pressing the **ACCESS CODE** key again, the operator will have access to the **PROGRAM** key for 10 minutes. When 10 minutes have elapsed, access to program key will be automatically disabled and the operator must return to Step No. 1 to gain access.

- Press **PROGRAM** key.
- PROGRAM MODE: SELECT SETPOINT** is displayed.
- When the voltage range and chiller full load amps have been entered, per instructions below, press the **ACCESS CODE** key to exit program mode and terminate access to program mode. **ACCESS TO PROGRAM MODE DISABLED** is displayed. The control center will automatically return to **LOCAL**, **REMOTE** or **SERVICE** mode which ever was last selected.

To enter **UNDERVOLTAGE** setpoints = (SOLID STATE STARTER APPLICATIONS ONLY)

- Press and release **SSS MOTOR CURRENT / VOLTS** key. The previously selected voltage range is displayed as follows:

SUPPLY VOLTAGE RANGE 200-208

or

SUPPLY VOLTAGE RANGE 220-240

or

SUPPLY VOLTAGE RANGE 380

or

SUPPLY VOLTAGE RANGE 400

or

SUPPLY VOLTAGE RANGE 415

or

SUPPLY VOLTAGE RANGE 440-480

or

SUPPLY VOLTAGE RANGE 550-600

or

SUPPLY VOLTAGE RANGE DISABLED

- Press and release the **ADVANCE DAY / SCROLL** key to scroll to the desired voltage range. Each time the **ADVANCE DAY / SCROLL** key is pressed, a different voltage range is displayed.

NOTE: The undervoltage cutout function can be disabled by scrolling to **SUPPLY VOLTAGE RANGE DISABLED**. This safety should not be arbitrarily disabled.

3. Press ENTER key.

To Enter Chiller Full Load Amps - (Solid State Starter Applications Only):

1. Press and release % **Current Limit** setpoint key. The following program prompt message is displayed:

```
CURRENT LIMIT = XXX% FLA: MTR CUR  
= FLA
```

2. Use entry keys to enter the desired current limit value and a proper chiller (job) full load amps. The chiller (job) full load amp value is found on the motor data plate or sales order.

3. Press and release **ENTER** key.

```
PROGRAM MODE. SELECT SETPOINT
```

 is displayed.

Check calibration as follows:

START CURRENT - Proper starting current is 45 % x Delta LRA. For example, if the motor nameplate Delta LRA (Locked Rotor Amps) is 2500A, the proper starting current is .45 x 2500 = 1125A. To check, start chiller and monitor motor current with clamp-on ammeter or monitor current with **SSS MOTOR CURRENT / VOLTS** keypad key (use in conjunction with display hold key).

OVERLOAD -

1. Ascertain correct **FLA** value is programmed @ keypad.
2. Run chiller.
3. Monitor highest phase (ØA, ØB, or ØC) or compressor motor current with clamp-on ammeter.
4. Monitor highest phase of compressor motor current using keypad **SSS MOTOR CURRENT / VOLTS** key in conjunction with **DISPLAY HOLD** key.
5. Display should read the same as clamp-on ammeter $\pm 5\%$. If it doesn't, refer to Solid State Starter troubleshooting Form 160.46-OM3.1.
6. Monitor highest phase of compressor motor current on keypad display using **SOLID STATE STARTER MOTOR CURRENT / VOLTS** key with **DISPLAY HOLD** key.
7. Manually operate vanes to run compressor motor to 105% FLA as indicated by the highest phase on the display.
8. Solid State Starter Logic Board 105% LED should just illuminate.
9. If system doesn't operate per above, calibration is necessary.

To calibrate, proceed as follows:

START CURRENT -

1. Monitor Motor Current using
 - a. a clamp-on ammeter,
 - or
 - b. **SOLID STATE STARTER MOTOR CURRENT / VOLTS** keypad key with **DISPLAY HOLD** key.

2. Start chiller.

3. When motor first begins to turn, adjust LCSSS Logic Board **START CURRENT POT (R38)** to achieve proper starting current **Clockwise** increases current, **Counter-Clockwise** decreases current. Proper start current is 45 % x Delta LRA.

NOTE: If monitoring the motor current on the display, there is a 2 second delay on display update.

Tighten R38 locking nut.

4. Restart chiller and check starting current.

OVERLOAD -

1. Ascertain correct **FLA** value is programmed at keypad.
2. Run chiller.
3. Monitor highest phase of compressor motor current on keypad display using **SSS MOTOR CURRENT / VOLTS** key with **DISPLAY HOLD** key.
4. Monitor highest phase of compressor motor current with clamp-on ammeter.
5. Display should read the same as clamp-on ammeter $\pm 5\%$. If it doesn't, refer to Solid State Starter troubleshooting Form 160.46-OM3.1.
6. Monitor highest phase of compressor motor current on keypad display using **SSS MOTOR CURRENT / VOLTS** key with **DISPLAY HOLD** key.
7. Manually operate vanes to run compressor motor to 105% FLA as indicated by the highest phase on the display.
8. Adjust LCSSS Logic Board **OVERLOAD POT (R44)** until LCSSS Logic Board 105% LED just illuminates.

Tighten R44 locking nut.

9. Re-check calibration.

PROXIMITY SENSOR CALIBRATION PROCEDURE

After the proximity sensor and probe are installed, either at the YORK factory when the compressor is built or when the proximity sensor and probe are field installed, or if the compressor is rebuilt in the field, the reference position must be established. This value must be entered at the keypad as the "REF POS" per the following procedure. This value will remain the "REF POS" value until the compressor is rebuilt or the proximity sensor module and probe are field replaced.

IMPORTANT

The "REF POS" value must be logged inside the MicroComputer Control Center because this value will have to be re-entered using the procedure below if the Micro Board or Micro Board RTC Chip (U16) is field replaced.

1. Place **COMPRESSOR SWITCH** in "STOP / RESET" position.
2. Press **ACCESS CODE** key
ENTER ACCESS CODE _ _ _ _ is displayed.
3. Using **ENTRY** keys, enter **1 3 8 0**.
4. Press **ENTER** key.
ACCESS TO PROGRAM MODE AUTHORIZED is displayed.
5. Press **PROGRAM** key.
PROGRAM MODE, SELECT SETPOINT is displayed.
6. Press **MODE** key. The present operating mode is displayed.
7. Press **ADVANCE DAY / SCROLL** key until
SERVICE OPERATING MODE SELECTED is displayed. Each time this key is pressed, a different mode is displayed.
8. Press **ENTER** key.
PROGRAM MODE, SELECT SETPOINT is displayed.
9. Press **ACCESS CODE** key.
ACCESS TO PROGRAM KEY DISABLED is displayed.
10. Press **MODE** key.
SERVICE MODE is displayed. If not repeat Steps 1 through 9.
11. Press **ACCESS CODE** key.

ENTER ACCESS CODE _ _ _ _ is displayed.

12. Using **ENTRY** keys, enter **1 3 9 7**.
13. Press **ENTER** key.
ACCESS TO PROGRAM KEY AUTHORIZED is displayed.
14. Press **PROGRAM** key.
PROGRAM MODE, SELECT SETPOINT is displayed.
15. Press **DISPLAY DATA** key.
 - **PROXIMITY SENSOR INITIALIZATION SEQUENCE** is displayed for 2 seconds.
 - **STARTING OIL PUMP** is displayed for 2 seconds. The oil pump automatically turns on.
 - **OIL PRESS XX.X PSID; 25 PSID MIN. REQ'D** is displayed until the oil pressure is more than 25.0 PSID. (The **CANCEL** key can be pressed, if desired, to turn off the oil pump and return to program mode prompt message).
 - **HIT ENTER TO CALIBRATE PROXIMITY SENSOR** is displayed.
16. Press **ENTER** key.
ACTUAL POS = XX MILS; REF POS = YY MILS is displayed.
17. Read both of the following steps and perform the appropriate one.
 - a. If the proximity sensor is being installed for the first time as part of a bearing retrofit or if the compressor has just been rebuilt or if the proximity sensor module and probe are field replaced, press the "*" key. This causes the "ACTUAL POS" value XX to be entered as the "REF POS" value YY. This establishes the reference position.

IMPORTANT

Log this value inside the MicroComputer Control Center for possible future use.

or

- b. If the Micro Board or Micro Board RTC Chip U16 has been replaced since the reference position was established, locate the original "REF POS" value that had been previously logged inside the

MicroComputer Control Center. Using the **ENTRY** keys, enter this value. As the digits are entered, they are displayed as the **REF POS = YY MILS** value.

18. Press **ENTER** key. The oil pump will turn off. **PROGRAM MODE, SELECT SETPOINT** is displayed. If values outside the range of 37 to 79 mils were entered as the "REF POS" in step 17a or 17b above. **OUT OF RANGE - TRY AGAIN** is displayed. If this out-of-range value was a result of step 17a above, troubleshooting of the proximity sensor module and interface is required.
19. Press **ACCESS CODE** key. **ACCESS TO PROGRAM KEY DISABLED** is displayed.

PROXIMITY / TEMP SENSOR SAFETY SHUTDOWN - SPECIAL RESET PROCEDURE

Anytime the chiller shuts down on "DAY-TIME-PROX SENSOR SAFETY SHUTDOWN" or "DAY-TIME-HIGH SPEED DRAIN TEMP" safety shutdowns, a qualified service engineer must perform steps a.) and b.) below. Anytime the chiller shuts down on **DAY-TIME-OPEN DRAIN TEMP THERMOCOUPLE**, a qualified service engineer must perform step b.) only.

- a. Perform an inspection of the high speed thrust bearing and thrust collar assembly to assure all critical clearances remain
and
- b. Perform the following special reset procedure. The chiller cannot be restarted until this reset procedure is performed. This special reset procedure does not appear in any publication other than this service manual. This prevents chiller operator personnel from restarting the chiller before a bearing inspection has been performed.

IMPORTANT!!

SERIOUS COMPRESSOR DAMAGE CAN OCCUR IF THE CHILLER IS RESTARTED WITHOUT PERFORMING THE BEARING INSPECTION!!!

The proximity sensor distance ("ACTUAL POS") must be within +10 mils or -20 mils of the "REF POS" (If the "REF POS" is < 42 mils, the minimum allowed distance is 22 mils) and the high speed drain temp must be 179°F or less prior to performing this procedure. Otherwise, the procedure will not be successful and the chiller cannot be restarted.

1. Place **COMPRESSOR SWITCH** in "STOP / RESET" position.

2. Press **ACCESS CODE** key. **ENTER VALID ACCESS CODE _ _ _ _** is displayed.
3. Using **ENTRY** keys, Enter **1 3 8 0**.
4. Press **ENTER** key. **ACCESS TO PROGRAM KEY AUTHORIZED** is displayed.
5. Press **PROGRAM** key. **PROGRAM MODE, SELECT SETPOINT** is displayed.
6. Press **MODE** key. The present operating mode will be displayed.
7. Press **ADVANCE DAY / SCROLL** key until **SERVICE OPERATING MODE SELECTED** is displayed.
8. Press **ENTER** key. **PROGRAM MODE, SELECT SETPOINT** is displayed.
9. Press **PROGRAM** key. **SYSTEM SHUTDOWN-PRESS STATUS** is displayed.
10. Press **WARNING RESET** key. **SYSTEM READY TO START** is displayed.
11. The control center can now be returned to **LOCAL** or **REMOTE** mode as required and the chiller can be started.

OPERATING HOURS AND STARTS COUNTER

The operating hours and starts counter should not be arbitrarily reset or changed. However, if the Micro Board, RTC Chip (U16) or EPROM is replaced, these values will be lost. The procedures below will allow the service technician to reset these values to zero or enter starting values.

RESETTING TO ZERO

Enter **PROGRAM MODE** per "SPECIAL PROGRAMMING PROCEDURES" above, then proceed as follows:

1. Press and release the unlabeled / unembossed key located under the **OPERATING HOURS** key. Then press and release the unlabeled / unembossed key located under the **DATA LOGGER** key.
2. The operating hours and starts counter will reset to zero.

ENTERING STARTING VALUES

Enter **PROGRAM MODE** per "SPECIAL PROGRAMMING PROCEDURES", above, then proceed as follows:

1. Press **OPERATING HOURS** key.
2. **OPER. HOURS = XXXXX; START COUNTER = XXXXX** is displayed.
3. Using the **ENTRY** keys, enter the desired values. Use leading zeroes where necessary (i.e., 00058). The operating hours must be entered first. When they are entered, the cursor will move to the first changeable digit of the start counter.
4. Press **ENTER** key.
5. **PROGRAM MODE, SELECT SETPOINT** is displayed.

SECTION 5 TESTING

DIAGNOSTIC SOFTWARE – YORK MICRO-COMPUTER CONTROL CENTER

The diagnostic software consists of six tests. These tests are Ram test, A/D test, display test, keyboard test, digital input test, and digital output test. The diagnostic software is stored in the same memory as the operating program. To enable the diagnostic, enter **SERVICE** mode and place the enable/disable jumper plug (on Micro Board) in the **ENABLE** position. To disable the diagnostic, leave **SERVICE** mode and place the enable/disable jumper plug in the **DISABLE** position. After the diagnostic is enabled, all further service technician interaction is done on the front panel keypad. When the diagnostic is enabled, the service technician is presented with a menu from which he can choose the test to be performed. The menu and six tests are described as follows:

CAUTION: Before performing this test, remove the jumper between terminals 24 and 25 on TB5 and press the manual trip button on 1M oil pump starter mounted on the condenser shell. This disables both the compressor motor and the oil pump starters. Upon completion of the test, replace the jumper between terms 24 and 25 on TB5 and reset the 1M oil pump starter.

MENU

Upon entering the diagnostic software the technician will observe a menu from which one of the six tests may be chosen. Press **9** key to view all five tests. The tests may be chosen by selecting the numeric key listed with the test. The keys and tests are as follows:

0—Ram test	3—Keyboard test
1—A/D test	4—Digital input test
2—Display test	5—Digital output test

The numeric keys are located under "Entry" on the front of the control center.

RAM TEST

This test will check all Ram locations in the system. The ram consists of two areas:

EXT—external Ram
RTC—Ram internal to the clock

After the test is completed the display will show the two areas with either a pass or fail. A failed condition would indicate that the Micro Board should be replaced. Press any key after the test is over to return to the main menu.

A/D TEST

This test will allow the technician to select any of the analog input channels and display the voltage on that channel on the display. The display will show the voltage found on that channel in volts (0-5.000V). Upon entering this test the technician will be asked to push one of the display function keys to select a group of analog channels; from here an individual channel may be selected. The analog channels associated with the display keys are as follows:

CHILLED LIQUID TEMPS

ECWT—entering chilled water temp
LCWT—leaving chilled water temp

(The analog voltage displayed for LCWT is that which is measured at IC U53 pin #7, not Micro Board input J19-10)

REFRIGERANT PRESSURES

PURG—purge pressure
COND—condenser pressure
EVAP—evaporator pressure

OIL PRESSURE

LOP—low oil pressure
HOP—high oil pressure

OPTIONS

Not Used

SSS MOTOR CURRENT/VOLTS

0 = line voltage range and starter size (ammeter scale) analog voltage
1 = 100% and 104% current limit command analog voltage
2 = ØC line voltage (C-A) analog voltage
3 = ØB line voltage (B-C) analog voltage
4 = ØA line voltage (A-B) analog voltage
5 = ØA motor current analog voltage
6 = ØB motor current analog voltage
7 = ØC motor current analog voltage

CONDENSER LIQUID TEMPS

ECNWT—Entering condenser water temp
LCNWT—Leaving condenser water temp

PRINT

DISCGT—Discharge Temp
OT—Oil Temp

% MOTOR CURRENT

NOTE: After pressing this key, press **SSS MOTOR CURRENT/VOLTS** key, then press #7 **ENTRY** key.

% FLA—Motor Current

OPERATING HOURS

Not Used

After tests are completed, press “*” key to return to main menu.

DISPLAY TEST

This test will make sure the display is functioning. Upon entering this test the technician will be instructed to push a key to start the test. Once the test has started the technician will see different characters scroll past on the display. Any key may be pushed after the test has started to return to the main menu.

KEYPAD TEST

This test allows the service technician to make sure that all of the keys on the keypad are functioning. Upon entering this test the technician will be instructed to press any of the keys. Upon pressing any of the keys a description of that key will be displayed on the display to determine if the keypad is working correctly. To exit this routine and return to the main menu the “*” key must be pushed.

DIGITAL INPUT TEST

This test will monitor the digital input lines to the system and determine if the lines and their associated devices are functioning properly. A mnemonic for each line will be displayed with its associated state (1 if the line is high or 0 if the line is low). The lines monitored and their associated mnemonics are:

STOP—stop line

MOCON—motor controller

AUX—auxilliary digital input

START—start line

TFS—top float switch

BFS—bottom float switch

HP—high pressure

VMS—vane motor switch

FLS—flow switch

BAT—battery back-up

SYSCY—remote/local cycling

MULCY—multi unit cycling

LEP—low evaporator pressure

LWT—low water temp

J54—chilled water pump program jumper

JP5—current unbalance program jumper

JP6—prerun program jumper

RSTRT—remote start switch

UV—untervoltage

RSTOP—remote stop switch

RLCWT—remote LCWT setpoint

RCURR—remote current setpoint

After tests are completed, press “*” key to return to main menu.

DIGITAL OUTPUT TEST

This routine allows the technician to monitor and change the state of the digital output lines. The technician will see an output line listed along with its present state (1 if the line is high or 0 if the line is low). At this time if the technician wishes to change the state of the line, press 1 to make the line high or 0 to make the line low. To leave this routine to return to the main menu press “*”. The digital output lines monitored are:

MOTOR STOP

VENT/LIQUID LINE

OIL RETURN

HIGH SPEED THRUST

OIL PUMP

CHILLED WATER PUMP

SAFETY SD

CYCLING SD

MOTOR START

PRV OPEN

PRV CLOSE

EMS (REMOTE MODE

READY TO START)

SECTION 6

TROUBLESHOOTING

INTRODUCTION

The failures or problems that could be encountered in the MicroComputer Control Center can be placed in seven major categories as follows:

- Digital Inputs
- Relay Outputs
- Keypad
- Analog Inputs
- EMI Noise
- Remote Setpoint Interface (4-20MA, 0-10VDC, Contact Closure)

Each category requires a specific procedure to resolve the problem. These procedures direct the troubleshooter along the path that leads to the identification of the prob-

lem. The troubleshooter should understand the operation of the MicroComputer Control Center and the function of each major component and PC board contained within the cabinet. Also the troubleshooter must understand the system interface and be able to utilize wiring diagrams to follow signal flow throughout the system.

Several levels of documentation are required for the troubleshooting process. The Control Center wiring diagram, supplied with every MicroComputer Control Center is the top level document. It provides the overall wiring and configuration. Sections of this instruction provide the required lower levels. Specifically, block diagrams provide signal flow and simplified representations of PC board circuitry. The "Inputs and Outputs" of each board provide details of the required voltage levels at all connectors on the PC boards.

SYSTEM START-UP CHECKLIST

- Verify configuration of Micro Board program jumpers
 - Refer to Fig. 31.
- Start Real-Time Clock
 - Refer to micro board jumper J57, Fig. 31.
- Program Setpoints
 - Refer to Operation Instruction Form 160.49-O1.
- Verify calibration (Ref. "System Calibration Procedures") as follows:
 - **ELECTRO-MECHANICAL STARTER APPLICATIONS – CM2 MODULE**
 - 100%
 - 105%
 - $\frac{LRA}{FLA}$ ratio Pot - R16
 - Starter Selection Switch - S1
- **LCSSS APPLICATIONS**
 - Full load amps setpoint
 - Supply voltage range setpoint
 - LCSSS Logic Board "Start Current" and "Overload"
 - LCSSS Logic Board 300V/600V AC Power Line Jumper

TROUBLESHOOTING PROCEDURES

DIGITAL INPUTS

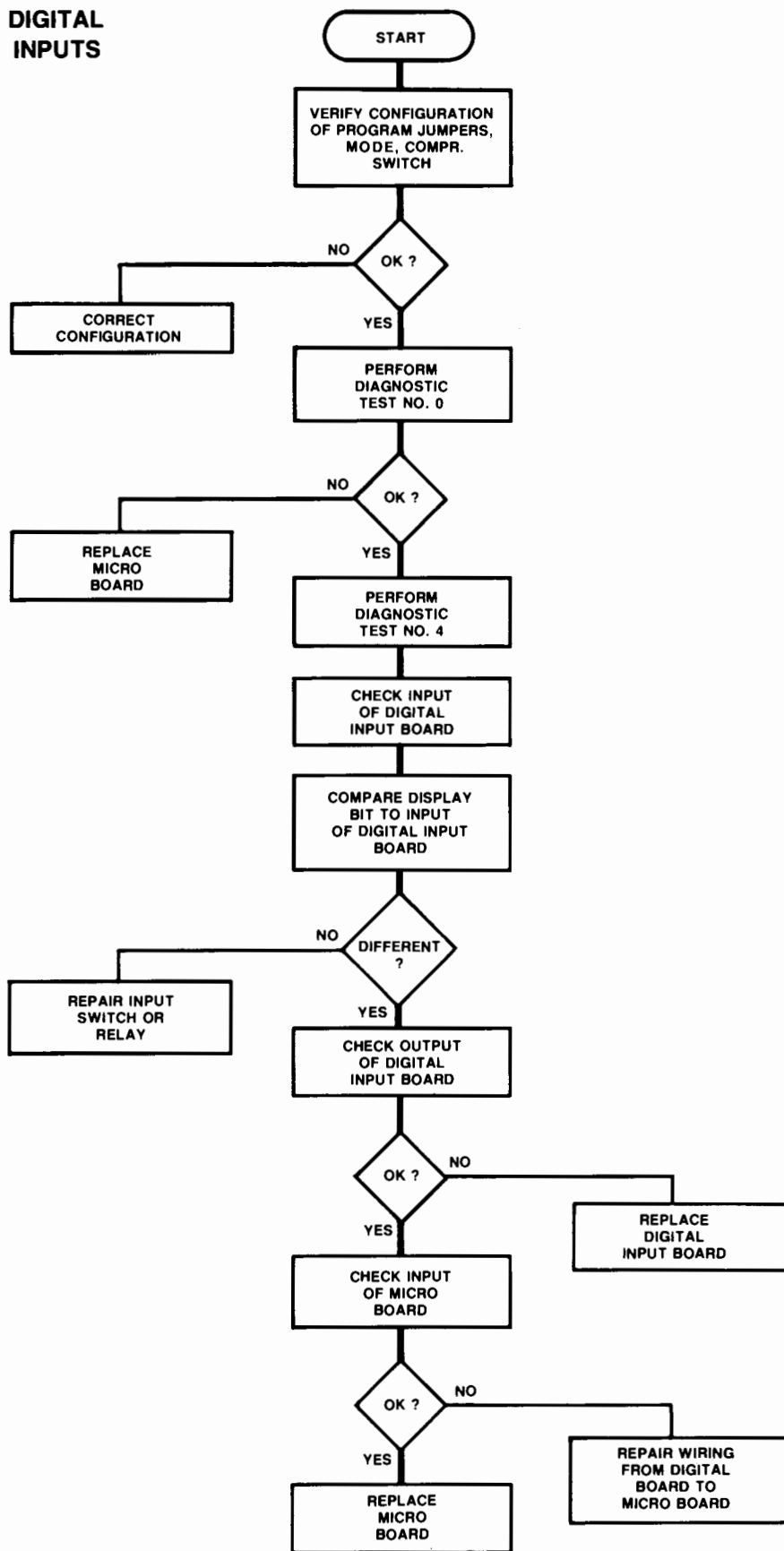
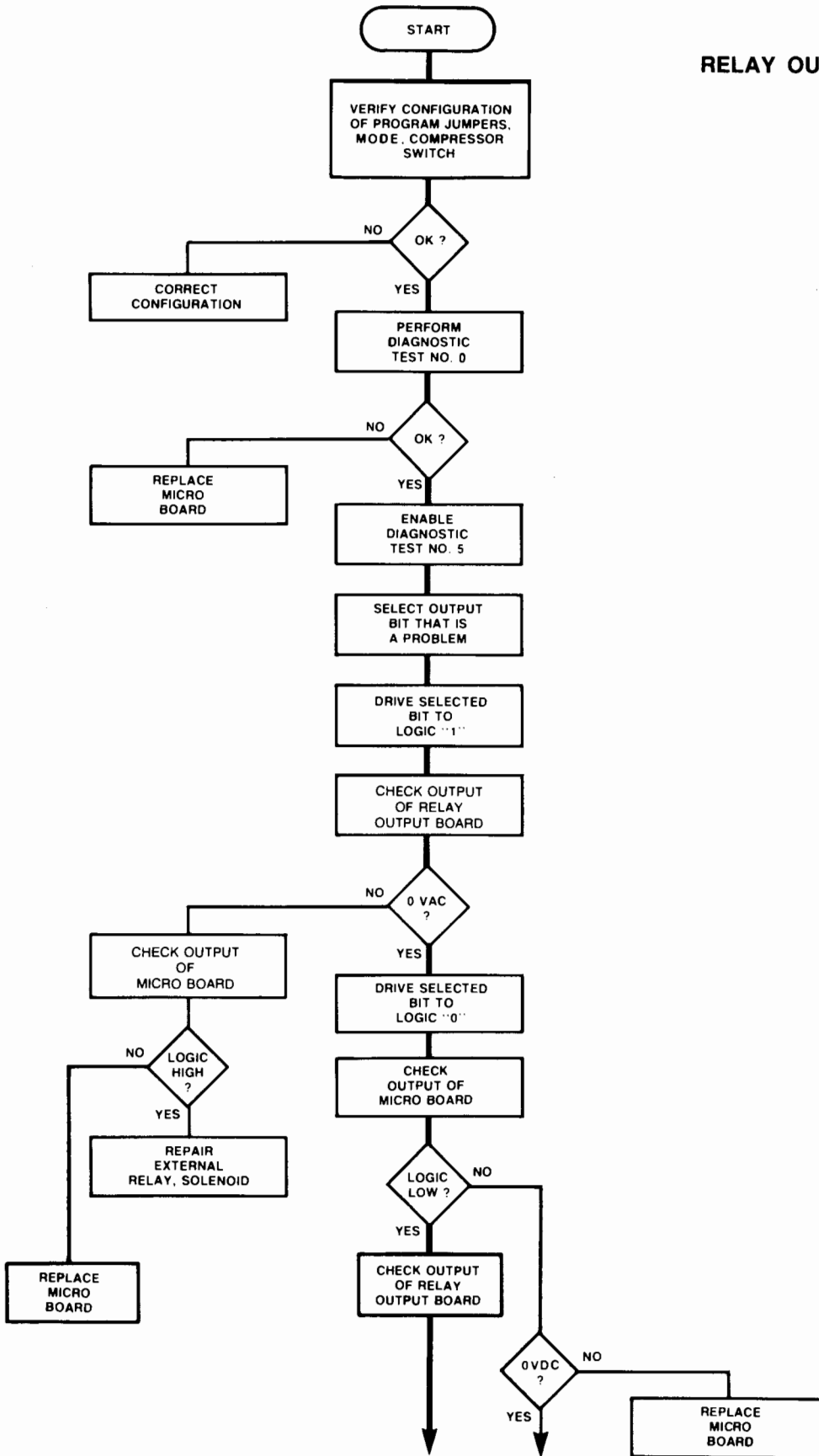

FIG. 44 — DIGITAL INPUTS TROUBLESHOOTING PROCEDURE
YORK APPLIED SYSTEMS

TROUBLESHOOTING PROCEDURES

RELAY OUTPUTS



Continued on Page 55

FIG. 45 — RELAY OUTPUTS TROUBLESHOOTING PROCEDURE

TROUBLESHOOTING PROCEDURES

Continued from Page 54

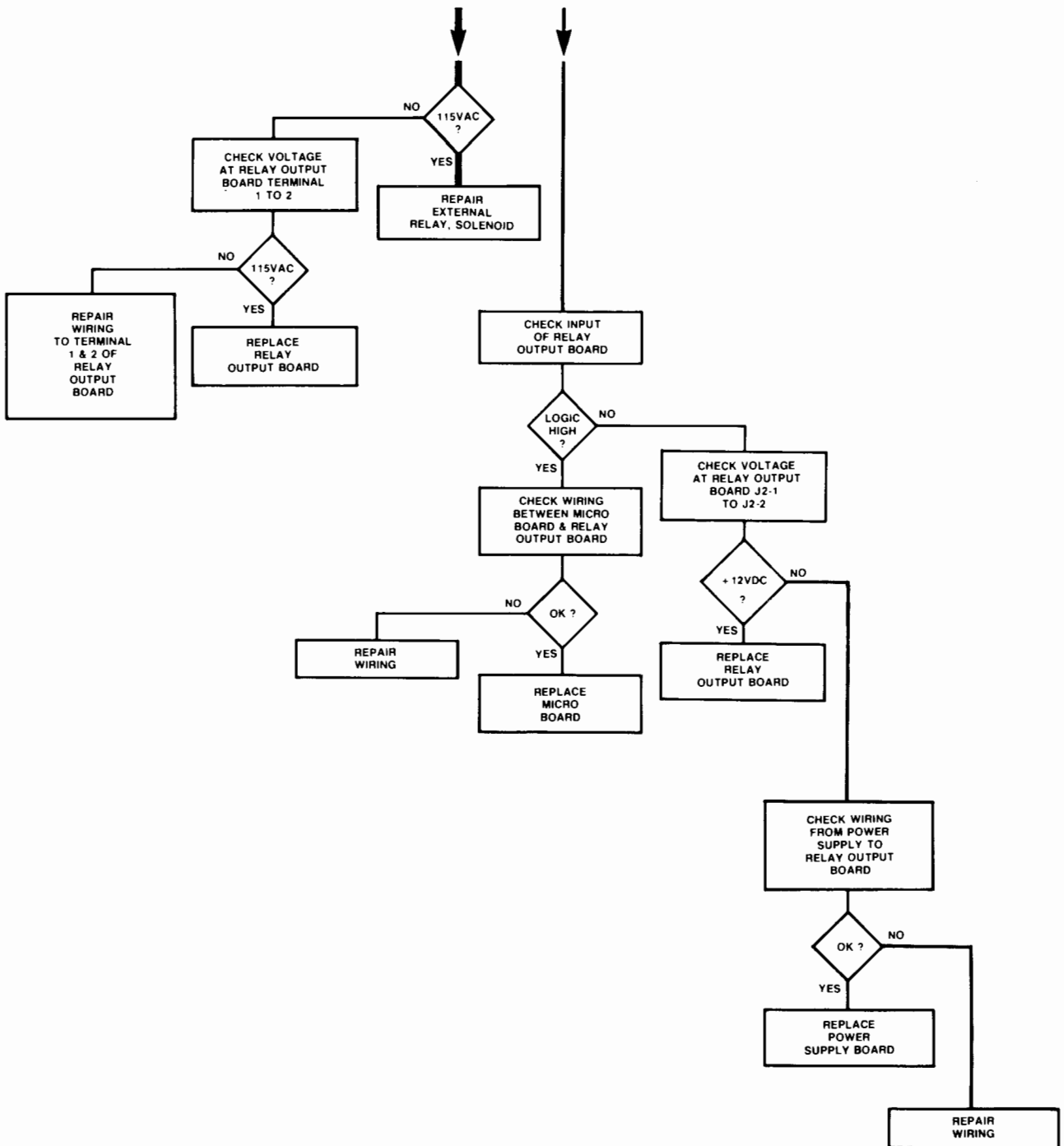

FIG. 46 — (CON'T) RELAY OUTPUTS TROUBLESHOOTING PROCEDURE

TROUBLESHOOTING PROCEDURES

KEYPAD KEYS

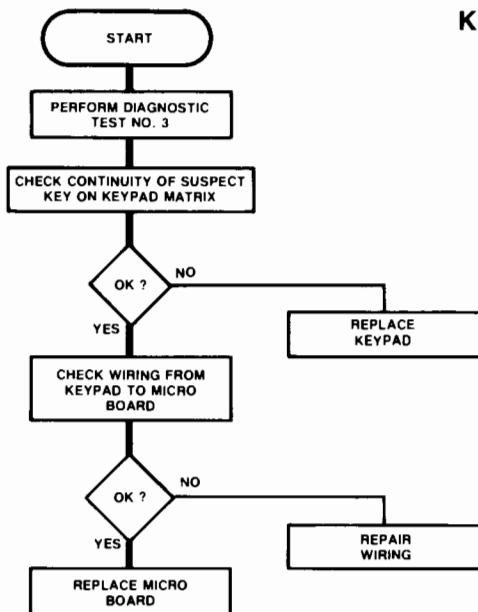

FIG. 47 -- KEYPAD KEYS TROUBLESHOOTING PROCEDURE

KEYPAD DISPLAY

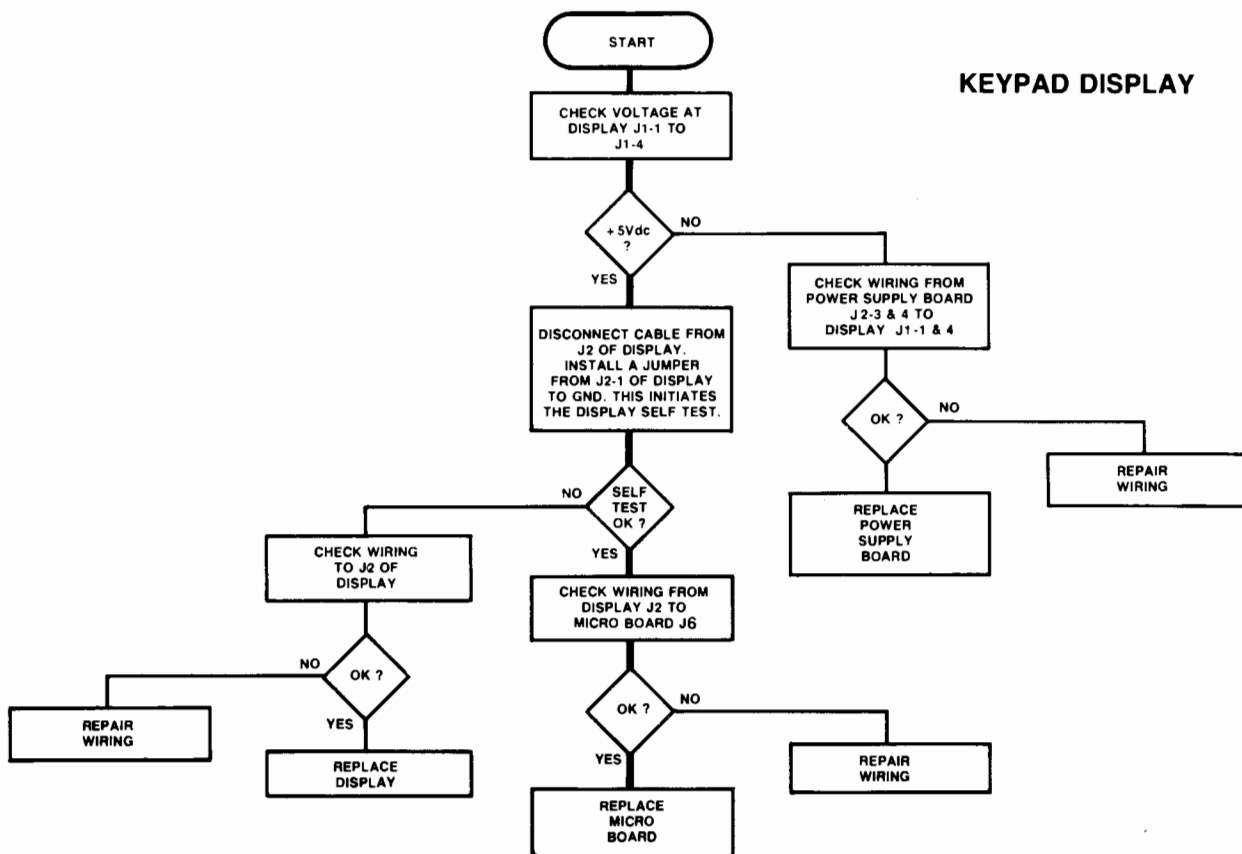

FIG. 48 -- KEYPAD DISPLAY TROUBLESHOOTING PROCEDURE

TROUBLESHOOTING PROCEDURES

ANALOG INPUTS (TRANSDUCERS & THERMISTORS)

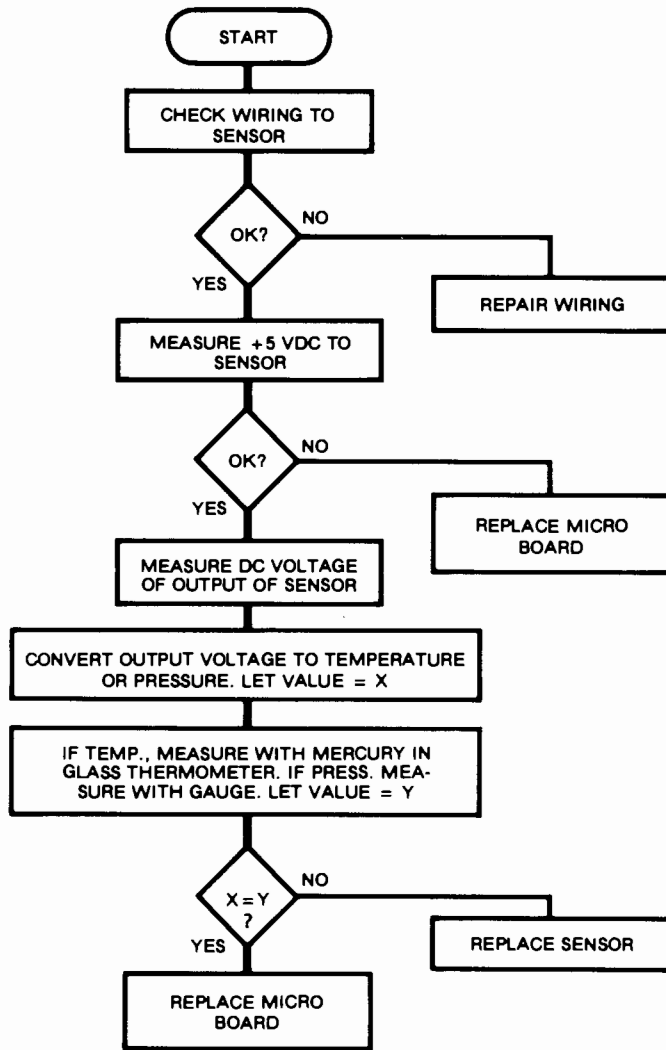

FIG. 49 — ANALOG INPUT-TRANSDUCERS AND THERMISTORS

TROUBLESHOOTING PROCEDURES

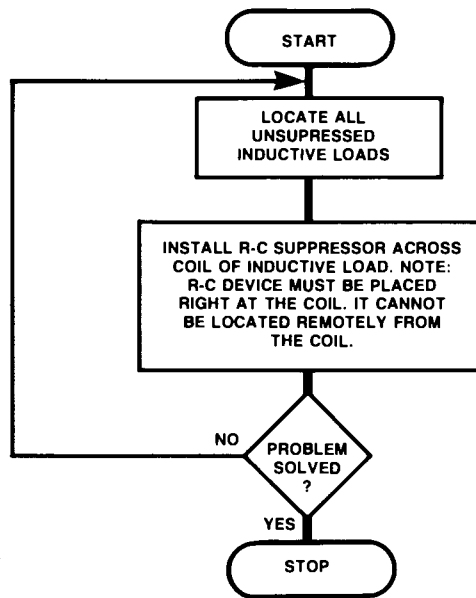

FIG. 50 — EMI NOISE TROUBLESHOOTING PROCEDURE

TROUBLESHOOTING PROCEDURES

CM-2 MODULE

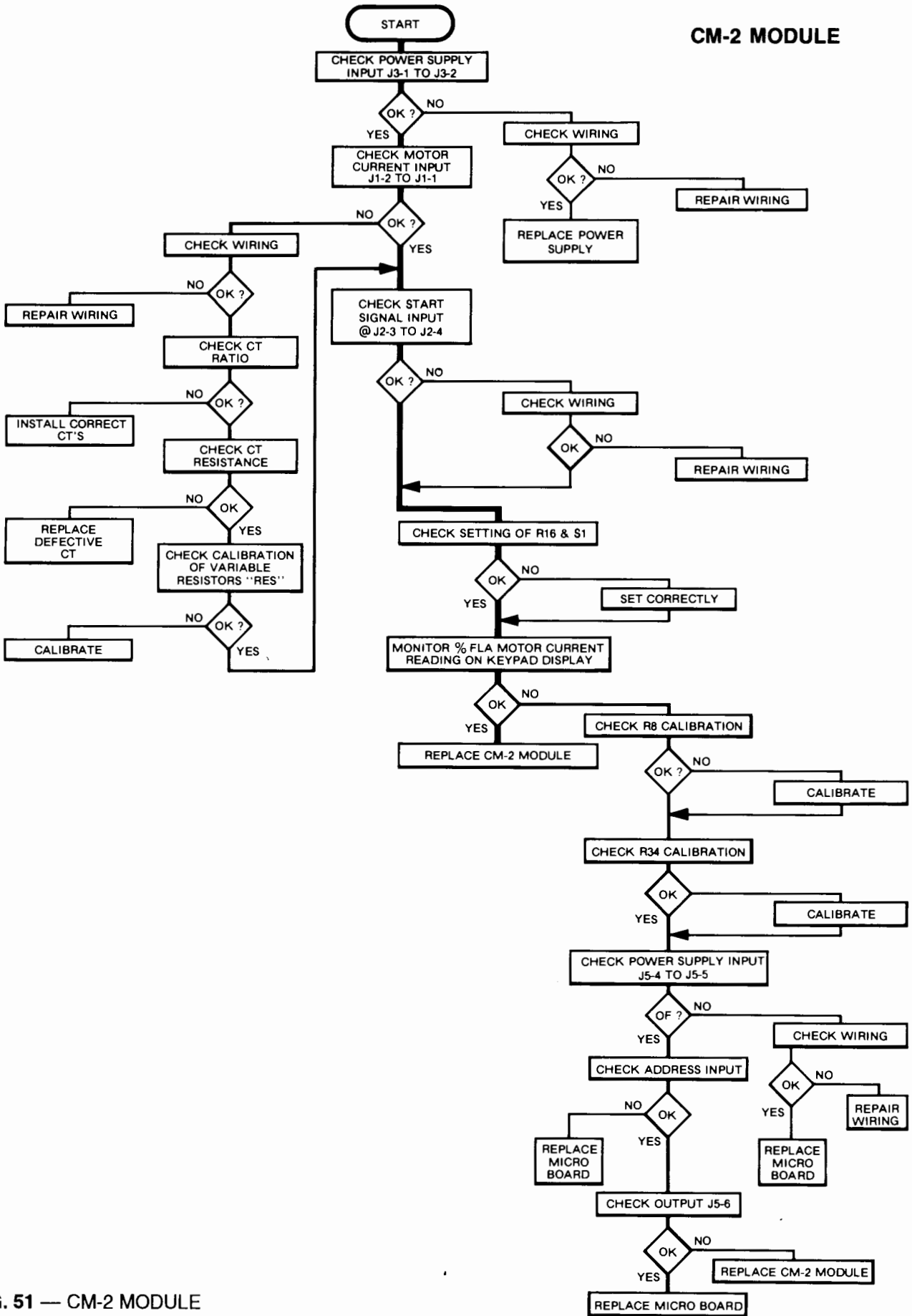

FIG. 51 — CM-2 MODULE

YORK APPLIED SYSTEMS

TROUBLESHOOTING PROCEDURES

REMOTE SETPOINT INTERFACE

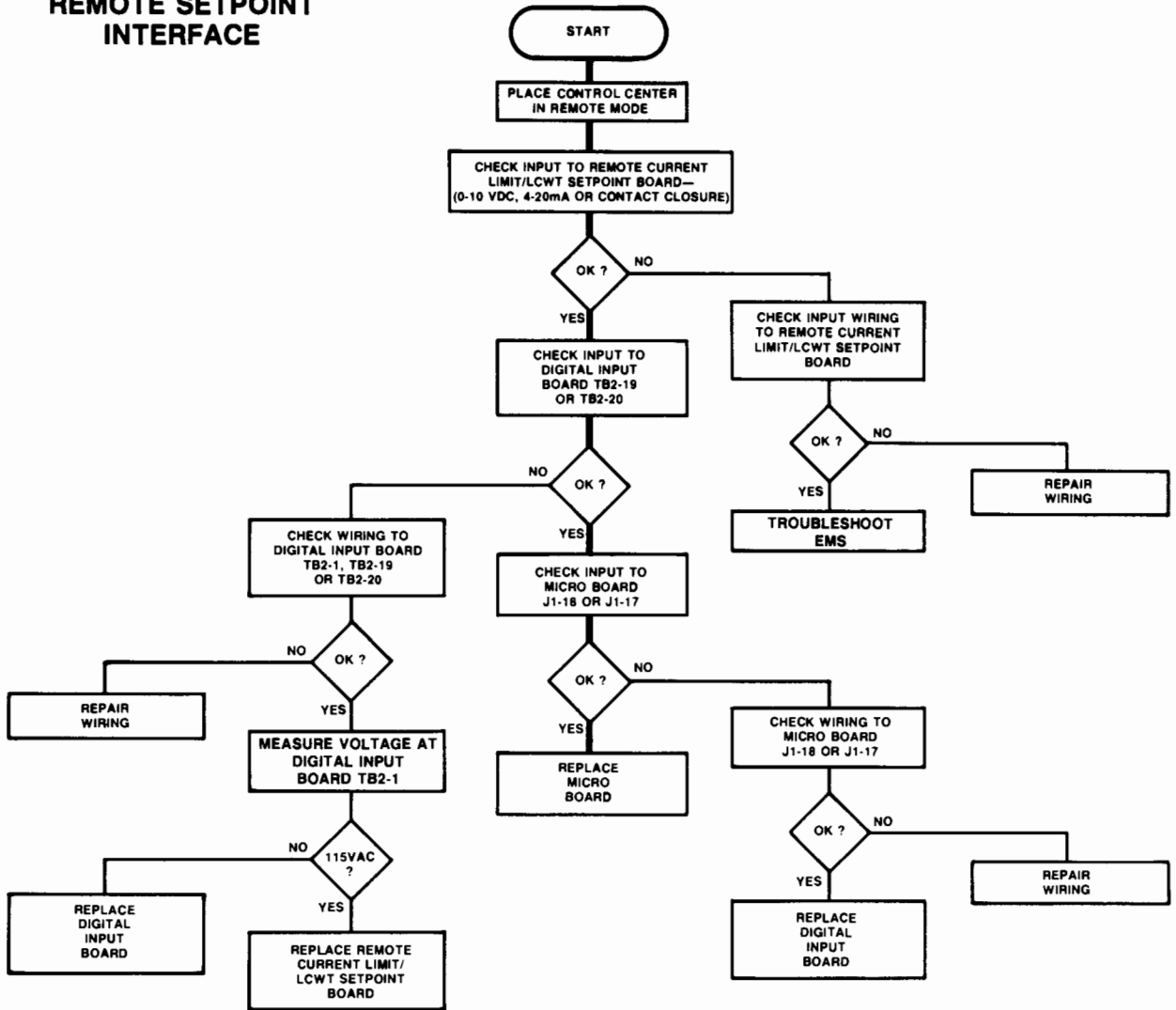

FIG. 52 – REMOTE SETPOINT INTERFACE

