



**MILLENNIUM™
CENTRIFUGAL LIQUID CHILLERS**

OPERATING & MAINTENANCE

Supersedes: Nothing

Form 160.49-O2 (1296)

**MODEL YK M3 M3 G4 THRU YK S6 S4 J2 (STYLE C)
R-22 (COOLING ONLY)**

**MODEL YK LB LB G4 THRU YK SE SC J4 (STYLE C)
R-134a (COOLING ONLY)**

**WITH MICROCOMPUTER CONTROL CENTER
PART #371-01200-010, 371-01200-011 & 371-01200-015
FOR ELECTRO-MECHANICAL STARTER,
SOLID STATE STARTER & VARIABLE SPEED DRIVE**



27385A

WARNING

SYSTEM CONTAINS REFRIGERANT UNDER PRESSURE.

SERIOUS INJURY COULD RESULT IF PROPER PROCEDURES ARE NOT FOLLOWED WHEN SERVICING SYSTEM. ALL SERVICE WORK SHALL BE PERFORMED BY A QUALIFIED SERVICE TECHNICIAN IN ACCORDANCE WITH YORK INSTALLATION/OPERATION MANUAL.

TABLE OF CONTENTS

	<u>Page</u>
SECTION 1 – Description of System and Fundamentals of Operation	4
SECTION 2 – MicroComputer Control Center	6
SECTION 3 – System Operating Procedures	30
SECTION 4 – System Component Description	37
SECTION 5 – Operational Maintenance	42
SECTION 6 – Trouble Shooting	44
SECTION 7 – Maintenance	49
SECTION 8 – Preventive Maintenance	58

REFERENCE INSTRUCTIONS

DESCRIPTION	FORM NO.
Solid State Starter – Operation & Maintenance	160.46-OM3.1
Variable Speed Drive – Operation	160.00-O1
Installation	160.49-N5
Installation and Operation of Printers	160.49-N7
Wiring Diagram – Unit with Electro-Mechanical Starter	160.49-PW7
Wiring Diagram – Field Connections (E-M Starter)	160.49-PW10
Wiring Diagram – Field Control Modifications	160.49-PW13
Wiring Diagram – Control Center with SS Starter	160.49-PW8
Wiring Diagram – Field Connections (SS Starter)	160.49-PW11
Wiring Diagram – Solid State Starter	160.49-PW14
Wiring Diagram – Unit with Solid State Starter	160.49-PW8
Wiring Diagram – Unit with Variable Speed Drive	160.49-PW9
Wiring Diagram – Field Connections (V.S.D.)	160.49-PW12
Wiring Diagram – Variable Speed Drive	160.49-PW15

NOMENCLATURE

R-22 UNITS

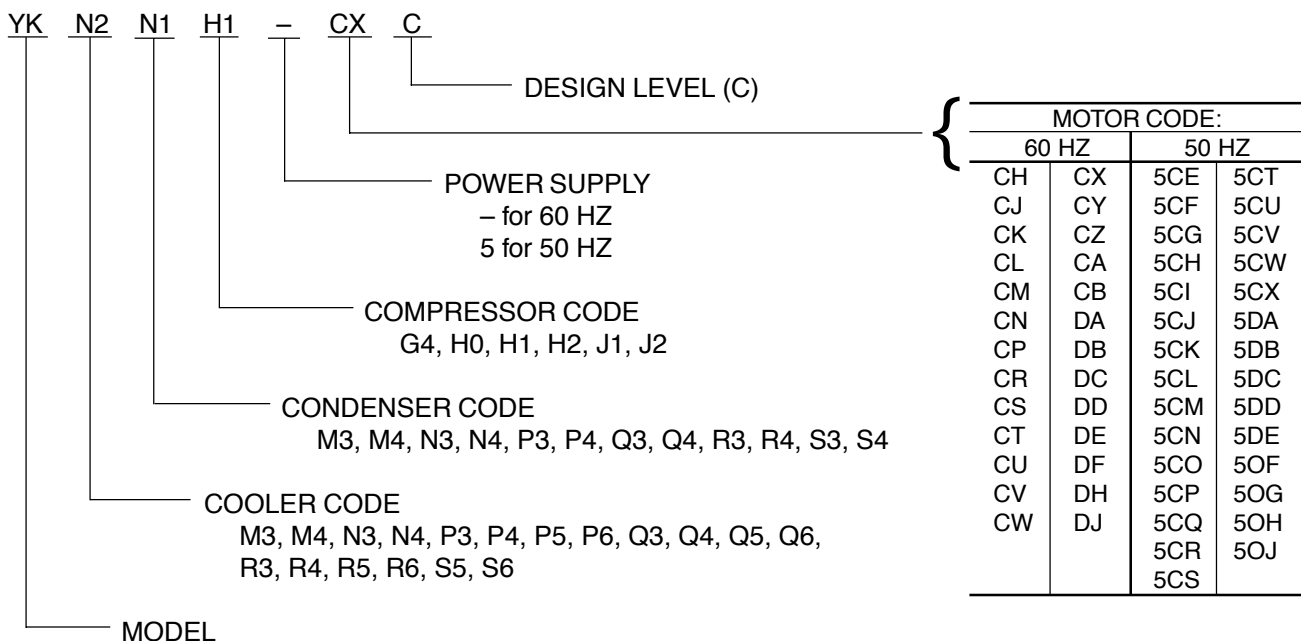

R-134a

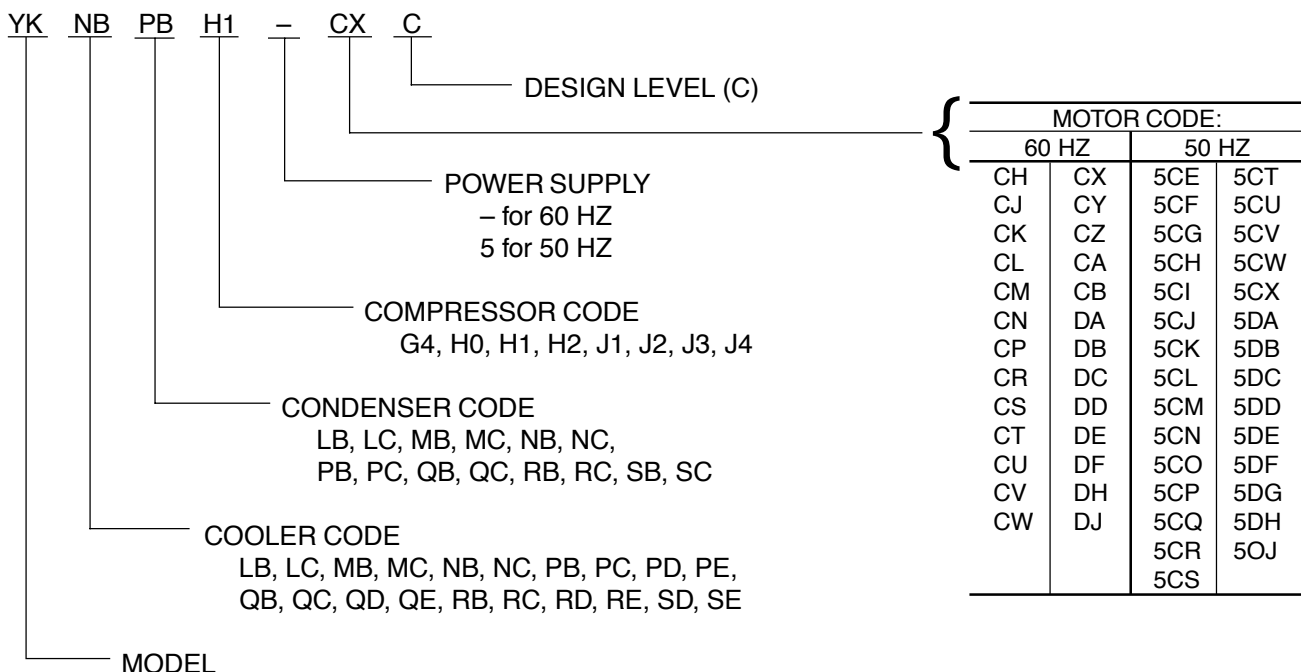

SECTION 1

DESCRIPTION OF SYSTEM AND FUNDAMENTALS OF OPERATION

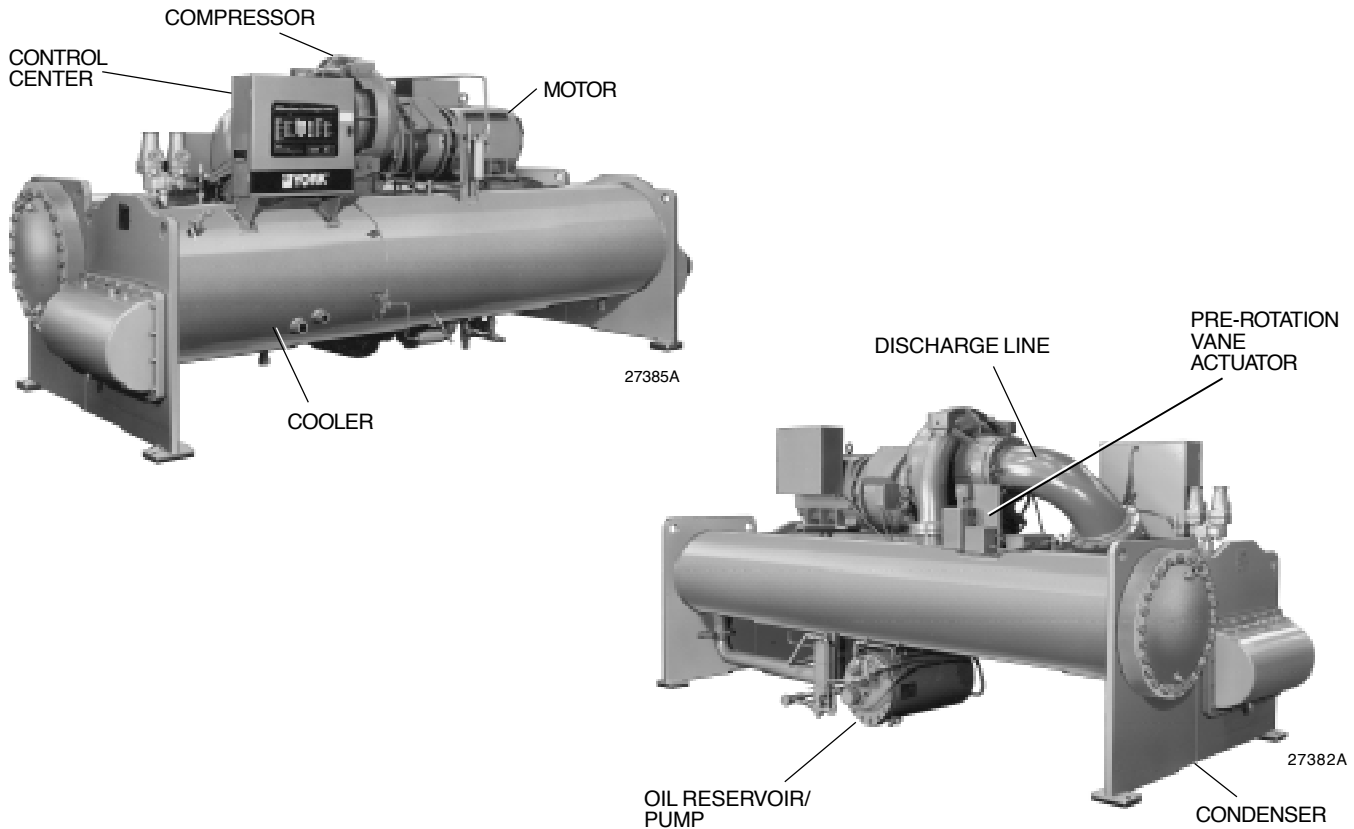

FIG. 1 – MODEL YK MILLENNIUM CHILLER

SYSTEM OPERATION DESCRIPTION (See Fig. 2)

The YORK Model YK Millennium Chiller is commonly applied to large air conditioning systems, but may be used on other applications. The chiller consists of an open motor mounted to a compressor (with integral speed increasing gears) condenser, cooler and flow control chamber.

The chiller is controlled by a modern state of the art MicroComputer Control Center which monitors its operation. The Control Center is programmed by the operator to suit job specifications. Automatic timed start-ups and shutdowns are also programmed to suit nighttime, weekends, and holidays. The operating status, temperatures, pressures, and other information pertinent to operation of the chiller are automatically displayed and read on a 40 character alphanumeric message display. Other displays can be observed by pressing the keys as labeled on the Control Center. The chiller with the MicroComputer Control Center is applied with an electro-mechanical starter, YORK Solid State Starter (optional), or Variable Speed Drive (optional).

In operation, a liquid (water or brine to be chilled) flows through the cooler, where boiling refrigerant absorbs heat from the water. The chilled liquid is then piped to fan coil units or other air conditioning terminal units, where it flows through finned coils, absorbing heat from the air. The warmed liquid is then returned to the chiller to complete the chilled liquid circuit.

The refrigerant vapor, which is produced by the boiling action in the cooler, flows to the compressor where the rotating impeller increases its pressure and temperature and discharges it into the condenser. Water flowing through the condenser tubes absorbs heat from the refrigerant vapor, causing it to condense. The condenser water is supplied to the chiller from an external source, usually a cooling tower. The condensed refrigerant drains from the condenser into the flow control chamber, where the flow restrictor meters the flow of liquid refrigerant to the cooler to complete the refrigerant circuit.

The major components of a chiller are selected to handle the refrigerant which would be evaporated at full load

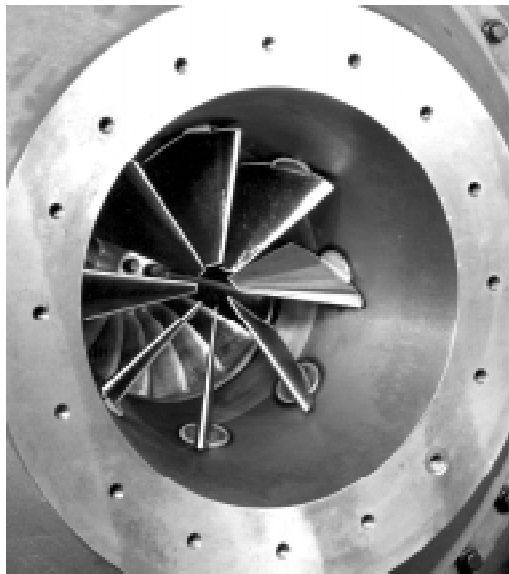

7619A(D)

DETAIL A – COMPRESSOR PREROTATION VANES

design conditions. However, most systems will be called upon to deliver full load capacity for only a relatively small part of the time the unit is in operation.

CAPACITY CONTROL

The major components of a chiller are selected for full load capacities, therefore capacity must be controlled to maintain a constant chilled liquid temperature leaving the cooler. Prerotation vanes (PRV), located at the entrance to the compressor impeller, compensate for variation in load (See Fig. 2. Detail A).

The position of these vanes is automatically controlled through a lever arm attached to an electric motor located outside the compressor housing. The automatic adjustment of the vane position in effect provides the performance of many different compressors to match various load conditions from full load with vanes wide open to minimum load with vanes completely closed.

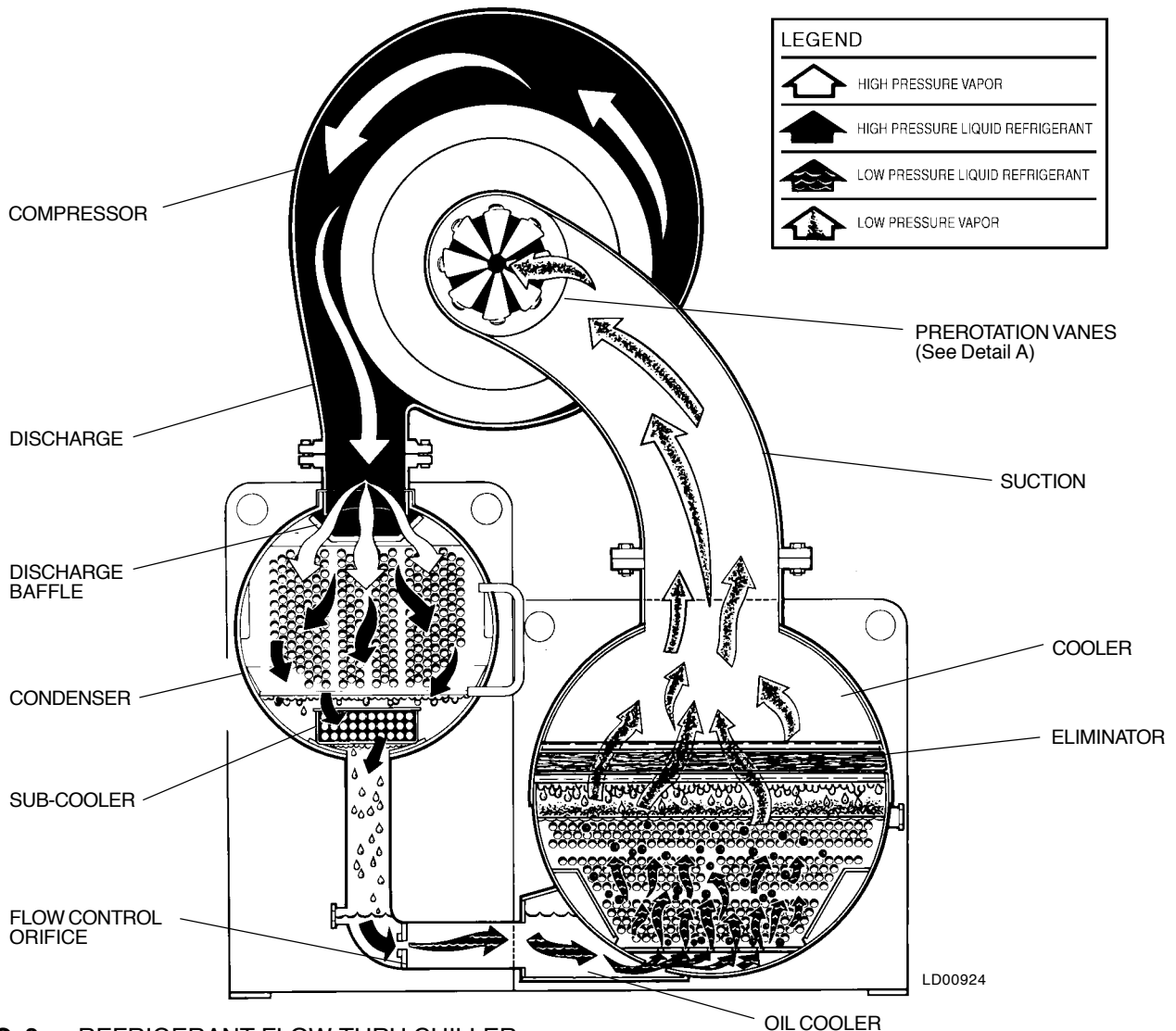

FIG. 2 – REFRIGERANT FLOW-THRU CHILLER

SECTION 2 MICROCOMPUTER CONTROL CENTER

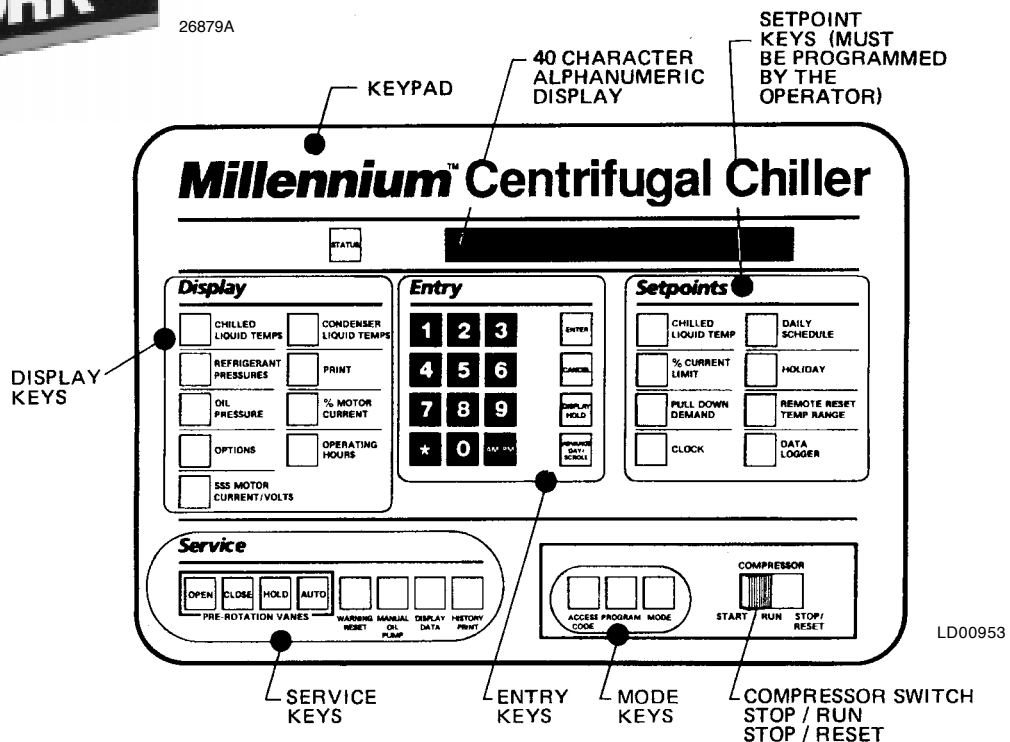

FIG. 3 – MICROCOMPUTER CONTROL CENTER AND KEYPAD

NOTE: This instruction covers operation of chillers equipped with Electro-Mechanical or Solid State Starters. If chiller is equipped with Variable Speed Drive, Form 160.00-O1 is to be used in conjunction with this manual.

WARNING

This equipment generates, uses and can radiate radio frequency energy and if not installed and used in accordance with the instructions manual, may cause interference to radio communications. Operation of this equipment in a residential area is likely to cause interference in which case the user at his own expense will be required to take whatever action may be required to correct the interference.

Additionally, any electronic equipment can generate EMI (electromagnetic interference) which, depending upon the installation and magnitude, may affect other electronic equipment. The amount of EMI generated is determined by the source inductance, load inductance, and circuit impedances. Responsibility for assuring the satisfactory operation of other equipment included in the same power source as the YORK equipment rests solely with the user. YORK disclaims any liability resulting from any interference or for the correction thereof.

INTRODUCTION

The YORK MicroComputer Control Center is a micro-processor based control system for R-22 or R134a centrifugal chillers. It controls the leaving chilled water temperature via pre-rotation vane control and has the ability to limit motor current via control of the pre-rotation vanes. Further, it is compatible with YORK Solid State Starter (optional), Variable Speed Drive (optional), and electro-mechanical starter applications.

A keypad mounted on the front of the Control Center (see Fig. 3) allows the operator to display system operating parameters on a 40 character alphanumeric display that is part of the keypad. These readings are displayed via "Display" keypad as follows: (In the English mode; temperatures in °F, pressures in (PSIG) (in the metric mode, temperatures in °C, Pressures in KPa).

If unit is equipped with EPROM version C.02F(T).12 or later, the Control Center can be equipped with an optional Chinese language display, either as a field retrofit or factory supplied option on new units. This display mounts on the control center door, directly above the standard display. Both the standard and Chinese display will be present, providing display messages simultaneously in both English and Chinese language.

The Control Center must be configured for Chinese display by a qualified service technician. Instructions are contained in YORK service manual, Form 160.49-M3.

- CHILLED LIQUID TEMPERATURES – LEAVING AND RETURN
- REFRIGERANT PRESSURES – EVAPORATOR AND CONDENSER
- DIFFERENTIAL OIL PRESSURE
- CONDENSER LIQUID TEMPERATURES – OPTIONAL FIELD INSTALLED – LEAVING AND RETURN
- OPTIONS
- PRINT *
- HISTORY PRINT *
- MOTOR CURRENT IN % OF FULL LOAD AMPS
- SATURATION TEMPERATURES – EVAPORATOR AND CONDENSER
- DISCHARGE TEMPERATURE
- OIL TEMPERATURE
- HIGH & LOW OIL PRESSURE TRANSDUCER PRESSURE
- SOLID STATE STARTER MOTOR CURRENT / VOLTS (When Supplied)
- CONDENSER REFRIGERANT LEVEL

* These keys provide a print-out when the customer connects a compatible printer to the Micro Board RS-232 serial port. (See Form 160.49-N7.)

The system setpoints (see Fig. 3) are operator entered on the front control center **Setpoints** keypad. These setpoints can also be displayed on the 40 character alphanumeric display. The system setpoints are:

- CHILLED LIQUID TEMPERATURE (LCWT)
- % CURRENT LIMIT
- PULLDOWN DEMAND LIMIT
- CLOCK (TIME-OF-DAY)
- DAILY SCHEDULE (7 DAY TIME-CLOCK PROGRAMMING)
- HOLIDAY
- REMOTE RESET TEMPERATURE RANGE
- DATA LOGGER
- CONDENSER REFRIGERANT LEVEL

The cause of all system shutdowns (safety or cycling) is preserved (until the system is reset or restarts) in the microcomputer's memory for subsequent viewing on the keypad display. The operator is continually advised of system operating conditions by various background and warning messages. The keypad contains special service keys for use by the service technician when performing system troubleshooting.

The MicroComputer Control Center is designed to be compatible with most Energy Management Systems (EMS) in use today. The standard design allows for the following EMS interface:

1. Remote Start
2. Remote Stop
3. Remote LCWT Setpoint (Pulse Width Modulated signal)
4. Remote Current Limit Setpoint (Pulse Width Modulated signal)
5. A "Remote Mode Ready to Start" Status Contacts
6. Safety Shutdown Status Contacts
7. Cycling Shutdown Status Contacts

As an enhancement to the standard EMS features, an optional card file with plug-in printed circuit boards is available. These optional cards will accept a remote LCWT 0 to 10°F or 0 to 20°F setpoint offset and/or remote current limit setpoint interface from three user input choices.

1. 4-20mA
2. 0-10VDC
3. Contact Closures

CONTROL CENTER

The Control Center front panel layout consists of five key groups, one switch and a 1 line by 40 character alphanumeric vacuum fluorescent display: (see Fig. 3.)

CHARACTERISTIC DISPLAY – The alphanumeric vacuum fluorescent display is located to the right of the **STATUS** key. All messages, parameters, set points, and data can be viewed at this location. The main communications between the operator or service technician and the MicroComputer Control Center occurs on this display.

DISPLAY – Provide a direct readout of each monitored parameter on the alphanumeric display.

ENTRY – These keys are used to enter the values for the operator programmed setpoints. These keys are used in conjunction with the **Setpoint** keys while in **PROGRAM** mode.

SETPOINTS – These keys are used as follows:

1. To view each setpoint, in any mode, or
2. To select the individual setpoints that are programmed by the operator in **PROGRAM** mode only.

Pressing the appropriate key enables the operator to program that setpoint pressing the **Entry** keys.

SERVICE – Included in this group of keys are those functions that are only relevant to servicing the chiller.

Typically, these keys would not be used for daily chiller operation.

ACCESS CODE – Permits operator to access the program.

PROGRAM – Permits operator to program the Control Center.

MODE – Permits operator to check what mode the Control Center is presently in (**LOCAL**, **REMOTE** or **SERVICE**).

1. **Service** – allows manual PRV control with visual display readout of PRV operation.
2. **Local** – allows manual compressor start from the **COMPRESSOR** switch on the Control Center front.
3. **Program** – allows operator programming of system setpoints.
4. **Remote** – allows remote start, remote stop of compressor and remote reset of LCWT and % current limit.

COMPRESSOR-START, RUN, STOP/RESET SWITCH – This 3-position rocker switch is used to start (except in **REMOTE** mode), stop/run/reset the system.

OPERATION

DISPLAYING SYSTEM PARAMETERS

The **Display** keys are used to display selected monitored parameters as follows: (Refer to Fig. 3.)

- Press and release the appropriate **Display** key – the message will be displayed for 2 seconds.

– or –

- Press and hold the appropriate **Display** key – the message will be displayed and updated every 0.5 seconds until the **Display** key is released.

– or –

- Press and release appropriate **Display** key, then press and release the **DISPLAY HOLD** key – the message

will be displayed and updated every 2 seconds until the **DISPLAY HOLD** key is again pressed and released, or 10 minutes have elapsed, whichever comes first.

NOTE: *If the display actually displays X's, then the monitored parameter is out of normal operating range (refer to Fig. 4). If the "English/Metric" jumper is installed on the Micro Board, all temperatures are displayed in degrees Fahrenheit (°F) and all pressures are displayed in pounds per sq. inch gauge (PSIG) except oil pressure which is displayed in pounds per sq. inch differential (PSID). If the "English/Metric" jumper is not installed, all temperatures are displayed in degrees Centigrade (°C) and all pressures are displayed in Kilo-Pascals (kPa).*

		DISPLAY READS
CONDENSER PRESS.	= < 6.8 PSIG, or > 300 PSIG	XX.X PSIG
EVAPORATOR PRESS.	= < 50 PSIG, or > 125 PSIG	XX.X PSIG
EVAP. PRESS. (BRINE)	= < 25 PSIG, or > 100 PSIG	XX.X PSIG
HOP TRANSDUCER	= < 59.1 PSIG, or > 314.9 PSIG	XX.X PSIG
LOP TRANSDUCER	= < 23.2 PSIG, or > 271.8 PSIG	XX.X PSIG
DISCHARGE TEMP.	= < 20.3°F; > 226.4°F	XXX.X°F
OIL TEMP.	= < 20.3°F; > 226.4°F	XXX.X°F
LEAVING CONDENSER WATER TEMP.	= < 8.4°F; > 134.1°F	XXX.X°F
ENTERING CONDENSER WATER TEMP.	= < 8.4°F; > 134.1°F	XXX.X°F
LEAVING EVAPORATOR WATER TEMP.	= < 0°F = > 81.1°F	XX.X°F XX.X°F
ENTERING EVAPORATOR WATER TEMP.	= < .1°F = > 93°F	XX.X°F XX.X°F

FIG. 4 – SYSTEM PARAMETERS – OUT OF RANGE READINGS

To Display **CHILLED LIQUID TEMPERATURES**:

Press **CHILLED LIQUID TEMPS** display key as described on page 7 to produce the following alphanumeric display message:

CHILLED LEAVING = XXX.X°F, RETURN = XXX.X°F

To Display **REFRIGERANT PRESSURE**:

Use **REFRIGERANT PRESSURE** display key as described on page 7 to produce the following alphanumeric display message:

EVAP = XXX.X PSIG; COND = XXX.X PSIG

To Display **OIL PRESSURE**:

Use **OIL PRESSURE** display key as described on page 7 to produce the following alphanumeric display message:

OIL PRESSURE = XXXX.X PSID

The differential pressure displayed is the pressure difference between the high side oil pressure transducer (output of oil filter) and the low side oil pressure transducer (compressor housing). Displayed value includes offset pressure derived from auto-zeroing during “START SEQUENCE INITIATED”. If either transducer is out-of-range, **XX.X** is displayed. Oil pressure is calculated as follows:

$$\text{PSID} = (\text{HOP} - \text{LP}) - \text{OFFSET PRESSURE}$$

OFFSET PRESSURE: Pressure differential between the HOP transducer and LOP transducer outputs during a 3 second period beginning 10 seconds after the start of “START SEQUENCE INITIATED”. During this time, the transducers will be sensing the same pressure and their outputs should indicate the same pressure. However, due to accuracy tolerances in transducer design, differences can exist. Therefore, to compensate for differences between transducers and assure differential pressure sensing accuracy, the **OFFSET PRESSURE** is subtracted algebraically from the differential pressure. The offset pressure calculation will not be performed if either transducer is out-of-range. The offset value will be taken as 0 PSI in this instance.

To Display **OPTIONS**:

This key is not used.

NO OPTIONS INSTALLED

is displayed when this key is pressed.

To Display **SSS MOTOR CURRENT / VOLTS**: (Solid State Starter Applications Only)

If chiller is equipped with a YORK Solid State Starter, use **SSS MOTOR CURRENT / VOLTS** key to display 3-phase compressor motor current and 3-phase Solid State Starter input line voltage.

Continuously pressing this key will display the motor current and line voltage alternately. When used with the **DISPLAY HOLD** key, motor current and line voltage will alternately be displayed each time this key is pressed. The messages are as follows:

A AMPS = XXXX; B AMPS = XXXX; C AMPS = XXXX

V A-B = XXXX; V B-C = XXXX; V C-A = XXXX

If chiller is not equipped with a Solid State Starter, this key produces the following message:

SOLID STATE STARTER NOT INSTALLED

In **PROGRAM** mode, this key is used to display the applicable line voltage range (200-208VAC, 220-240VAC, 380VAC, 400VAC, 415VAC, 440-480VAC, 500-600VAC, Supply Voltage Range Disabled). The correct line voltage range is programmed at the YORK factory and is checked by the service technician at start-up. For security reasons, a special access code is required to program the line voltage range. The line voltage range is used to determine a low line voltage threshold for cycling shut-down. Refer to “System Setpoints” for Trip/Reset values.

To Display **CONDENSER LIQUID TEMPERATURES (Field Installed Option Package)**:

Use **CONDENSER LIQUID TEMPS** display key as described above to produce the following alphanumeric display message:

COND LEAVING = XXX.X°F; RETURN = XXX.X°F

NOTE: If the condenser liquid thermistors are not connected, or both thermistors are “out of range”, the display will blank when this key is pressed.

To Initiate a **PRINT** to Printer:

Press the **PRINT** key to initiate a printout to an optional printer. When the key is pressed,

PRINT ENABLE is displayed.

Refer to “MicroComputer Control Center – System Status Printers” instruction, Form 160.49-N7 for details of the optional printers.

To Display **MOTOR CURRENT**:

Press the % **MOTOR CURRENT** display key as described above to display motor current as a percent of Full Load Amps (FLA). The message is as follows:

MOTOR CURRENT = XXX% FLA

NOTE: • Liquid-Cooled Solid State Starter Applications – the % Motor Current displayed is the highest of three line currents divided by the programmed chiller FLA value x 100%.

• Electro-Mechanical Starter Applications – the % Motor Current displayed is the highest of the three line currents.

To Display **OPERATING HOURS** and **STARTS COUNTER**:

Use the **OPERATING HOURS** key as described on page 8, to produce the following message:

OPER. HOURS = XXXXX; START COUNTER = XXXXX

NOTE: The operating hours and starts counter can be reset to zero. Refer to “Programming the Micro-

Computer Control Center”, page 14. However, the purpose of the **OPERATING HOURS** key is to display the total accumulated chiller run time. Therefore, the operating hours should not be arbitrarily reset.

SYSTEM SETPOINTS

The system setpoints may be programmed by the system operator. The **Setpoints** keys are located on the Control Center keypad (see Fig. 3). To program, see “Programming System Setpoints”, page 14. The following is a description of these setpoints (with the English/Metric jumper installed on the Micro Board):

CHILLED LIQUID TEMP – This key displays the leaving chilled water temperature (LCWT) setpoint in degrees Fahrenheit. If not programmed, the default value is 45°F. See “Programming System Setpoints”, page 15).

NOTE: If an Energy Management System is interfaced to the Control Center for the purpose of remote LCWT setpoint reset, then the operator-programmed chilled liquid temperature will be the base or lowest setpoint available to the Energy Management System (EMS). This chilled liquid temperature value must also be entered into the EMS. Further, any subsequent change to this value must also be entered into the EMS.

% CURRENT LIMIT – This key displays the maximum value of motor current permitted by its programmed setting. The value is in terms of percent of Full Load Amps (FLA). If not programmed, the default value is 100%. (See “Programming System Setpoints”, page 15.)

If chiller is equipped with a YORK Solid State Starter, the system FLA is also displayed. This value is programmed by the factory and should never be changed. The Micro Board uses this value to calculate and display the % motor current parameter that is displayed when the % **MOTOR CURRENT** display key is pressed. Also, proper current limit control depends on the correctly programmed FLA value. For security reasons, a special access code is required to program the FLA value. It should only be changed by a service technician.

PULL DOWN DEMAND – This function is used to provide energy savings following the chiller start-up. This key displays a programmable motor current limit and a programmable period of time. Operation is as follows: Whenever the system starts, the Pull Down Demand Limit is maintained for the programmed time, then the current limit control returns to % current limit setpoint. The maximum permitted motor current is in terms of % FLA. The duration of time that the current is limited is in

terms of minutes (to a maximum of 255). If not programmed, the default value is 100% FLA for 00 minutes. (See “Programming Systems Setpoints”, page 16.) Thus, no pull down demand limit is imposed following system start, and the % current limit setpoint is used.

CLOCK – This key displays the day of the week, time of day and calendar date. If not programmed, the default value is **SUNDAY 12:00 AM 1/1/92**. (See “Programming System Setpoints”, page 16.)

DAILY SCHEDULE – This key displays the programmed daily start and stop times, from Sunday thru Saturday plus Holiday. If desired, the Control Center can be programmed to automatically start and stop the chiller as desired. This schedule will repeat on a 7-day calendar basis. If the Daily Schedule is not programmed, the default value is 00:00 AM start and stop times for all days of the week and the holiday. (Note that the system will not automatically start and stop on a daily basis with these default values because 00:00 is an “Impossible” time for the Micro Board. See “Programming System Setpoints”, page 17.) Finally, one or more days in the week can be designated as a holiday (see description under **HOLIDAY** setpoint) and the Control Center can be programmed (usually **Daily Schedule** setpoint) to automatically start and stop the chiller on those days so designated. The operator can override the time clock at any time using the **COMPRESSOR** switch.

Note that if only a start time is entered for a particular day, the compressor will not automatically stop until a scheduled stop time is encountered on a subsequent day.

HOLIDAY – This key indicates which days in the upcoming week are holidays. On those designated days, the chiller will automatically start and stop via the holiday start and stop times programmed in the **DAILY SCHEDULE** setpoint. It will do this one time only and the following week will revert to the normal daily schedule for that day.

REMOTE / RESET TEMP RANGE – This key displays the maximum offset of remote LCWT setpoint reset. This offset is either 10° or 20°F as programmed. When in the **REMOTE** mode, this value is added to the operator programmed **CHILLED LIQUID TEMP** setpoint and the sum equals the temperature range in which the LCWT can be reset. For example, if the operator programmed **CHILLED LIQUID TEMP** setpoint is programmed with a value of 10°F, then the **CHILLED LIQUID TEMP** setpoint can be remotely reset over a range of 46°F to 56°F (46 + 10 = 56). If not programmed, the default value for this parameter is 20°F.

For additional information on remote LCWT reset, refer to Form 160.49-PW13.

NOTE: If an Energy Management System is interfaced to the Control Center for the purpose of remote LCWT setpoint reset, then the operator programmed **REMOTE RESET TEMP RANGE** value determines the maximum value of temperature reset controlled by the Energy Management System.

DATE LOGGER – This key is used when an optional printer is connected to the MicroComputer Control Center. Refer to Form 160.49-N7 for operation instructions.

SSS MOTOR CURRENT/VOLTS – This key is used on Solid State Starter applications only. Although this is a display key, it is used to program the applicable AC power line voltage range (380VAC, 400VAC, 415VAC, 440-480VAC, 550-600VAC). The MicroComputer Control Center uses this entry to determine the under-voltage and overvoltage shutdown threshold. For each line voltage category, there is an undervoltage and overvoltage shutdown threshold. If the AC power line voltage exceeds these thresholds for 20 continuous seconds, the chiller shuts down and displays

MON 10:00 AM LOW LINE VOLTAGE

– or –

MON 10:00 AM HIGH LINE VOLTAGE

This overvoltage and undervoltage protection can be disabled. Refer to chart below:

LOW / HIGH LINE VOLTAGE TRIP / RESET VALUES				
COMPRESSOR MOTOR SUPPLY VOLTAGE RANGE – (V)	LOW LINE VOLTAGE OPERATING POINT		HIGH LINE VOLTAGE OPERATING POINT	
	CUTOUT-(V) (ON FALL)	CUTIN-(V) (ON RISE)	CUTOUT-(V) (ON RISE)	CUTIN-(V) (ON FALL)
380	305	331	415	414
400	320	349	436	435
415	335	362	454	453
440-480	370	400	524	523
550-600	460	502	655	654
Supply Voltage Range Disabled	NONE	0	NONE	0

For security reasons, a special access code is required to program the supply voltage range. The supply voltage range is programmed at the factory and should only be changed by a service technician.

DISPLAYING SYSTEM SETPOINTS

The currently programmed **Setpoint** values can be viewed at any time (see page 22) in **SERVICE, LOCAL** or **REMOTE** operating mode as follows:

- Press and release the appropriate **Setpoint** key – the message will be displayed for 2 seconds.

– or –

- Press and hold the appropriate **Setpoint** key – the message will be displayed as long as the key is pressed.

– or –

- Press and release the appropriate **Setpoint** key, then press and release the **DISPLAY HOLD** key. The message will be displayed until the **DISPLAY HOLD** key is again pressed and released, or 10 minutes have elapsed, whichever comes first.

To Display **CHILLED LIQUID TEMP** Setpoint:

Use **CHILLED LIQUID TEMP** setpoint key as described on page 10 to produce the following message:

LEAVING SETPOINT = XX.X °F

NOTE: The value displayed is the actual LCWT setpoint. For example, the value displayed in **LOCAL** or **PROGRAM** modes is that which is operator programmed. The value displayed in the **REMOTE** mode is that base setpoint with added temperature reset by an Energy Management System, via remote LCWT setpoint (PWM signal) if a remote reset signal was received within 30 minutes.

To Display % **CURRENT LIMIT** Setpoint:

Use % **CURRENT LIMIT** setpoint key as described above to produce the following message:

CURRENT LIMIT = XXX % FLA

NOTE: The value displayed is the actual % current limit setpoint. For example, the value displayed in **LOCAL** or **PROGRAM** mode is that which is operator programmed. The value displayed in the **REMOTE** mode is that which has been programmed by the Energy Management System via the remote current limit setpoint input.

If chiller is equipped with a YORK Solid State Starter, the message is:

CURRENT LIMIT = XXX % FLA; *MTR CUR = 000 FLA

NOTE: On Solid State Starter applications, this value is programmed at the YORK factory. A special access code is required.

To Display **PULL DOWN DEMAND** Setpoint:

Use **PULL DOWN DEMAND** setpoint key as described on page 10 to produce the following message:

SETPOINT = XXX MIN @ XX % FLA XXX MIN LEFT

To Display **CLOCK** Setpoint (Time of Day):

Use **CLOCK** setpoint key as described above to produce the following message:

TODAY IS DAY XX:XX AM/PM 1/1/92

To Display **DAILY SCHEDULE** Setpoints:

- Press and hold the **DAILY SCHEDULE** setpoint key.

The chiller start and stop times for each day of the week are sequentially displayed, beginning with Sunday and ending with Holiday. The display will continuously scroll until the **DAILY SCHEDULE** key is released.

– or –

- Press and release the **DAILY SCHEDULE** setpoint key. Then press and release the **DISPLAY HOLD** key. The chiller start and stop times for each day of the week are sequentially displayed beginning with Sunday and ending with Holiday. The display will continuously scroll until the **DISPLAY HOLD** key is again pressed and released, or 10 minutes have elapsed, whichever comes first.

The display message for **DAILY SCHEDULE** will scroll in the following sequence:

SUN START = 08:30 AM STOP = 06:00 PM

MON START = 05:00 AM STOP = 07:00 PM

TUE START = 05:00 AM STOP = 07:00 PM

WED START = 05:00 AM STOP = 07:00 PM

THU START = 05:00 AM STOP = 07:00 PM

FRI START = 05:00 AM STOP = 07:00 PM

SAT START = 05:00 AM STOP = 01:00 PM

HOL START = 00:00 AM STOP = 00:00 PM

To Display **HOLIDAY** Setpoints:

Use **HOLIDAY** setpoint key as described in the beginning of this section to produce the following message:

S _ M _ T _ W _ T _ F _ S _ HOLIDAY NOTED BY *

NOTE: On the days that are designated by an *, the chiller will automatically start and stop per the holiday schedule established in **DAILY SCHEDULE** setpoints.

To Display **REMOTE RESET TEMP RANGE** Setpoint:

Use **REMOTE RESET TEMP RANGE** setpoint key as described above to produce the following message:

REMOTE RESET TEMP RANGE = 10°F

– or –

REMOTE RESET TEMP RANGE = 20°F

To Display **DATA LOGGER** setpoints:

Refer to YORK, Form 160.49-N7 for operation of this key.

To Display **UNDERVOLTAGE** setpoints:
(Solid State Starter Applications Only)

Press **SSS MOTOR CURRENT/VOLTS** key in **PROGRAM** mode to display the selected voltage range. One of the following messages will be displayed.

SUPPLY VOLTAGE RANGE 380

– or –

SUPPLY VOLTAGE RANGE 400

– or –

SUPPLY VOLTAGE RANGE 415

– or –

SUPPLY VOLTAGE RANGE 440-480

– or –

SUPPLY VOLTAGE RANGE 550-600

– or –

SUPPLY VOLTAGE RANGE DISABLED

A special access code is required to program the Supply Voltage Range. The Supply Voltage Range is programmed at the factory and checked at system start-up. (Note to service technician: Refer to programming instructions in Service Instruction, Form 160.49-M3.)

PROGRAMMING THE MICROCOMPUTER CONTROL CENTER

PROGRAMMING SYSTEM SETPOINTS

The system setpoints can be entered at any time even when the system is running. Proceed as follows to enter system setpoints. (Refer to Fig. 5.)

1. Press **ACCESS CODE** key.
2. **ENTER VALID ACCESS CODE _ _ _ _** is displayed.
3. Using **ENTRY** keys, enter **9 6 7 5**.
4. As each digit is entered, the characters **Y O R K** are displayed.

NOTE: If digits other than **9 6 7 5** are entered, **Y O R K** is still displayed.

NOTE: For ease in remembering the code, note that the letters **Y O R K** correspond to the digits **9 6 7 5** on a telephone dial.

5. Press **ENTER** key.
6. **ACCESS TO PROGRAM KEY AUTHORIZED** is displayed.

NOTE: Unless terminated by pressing the **ACCESS CODE** key again, the operator will have access to the **PROGRAM** key for 10 minutes. When 10 minutes have elapsed, access to **PROGRAM** key will be automatically disabled and the operator must return to step No. 1 to gain access.

7. Press **PROGRAM** key.
8. **PROGRAM MODE, SELECT SETPOINT** is displayed.

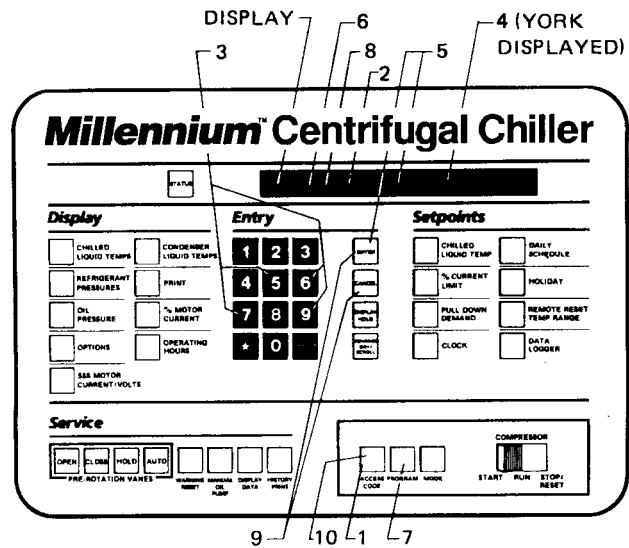

LD00954

FIG. 5 – KEYPAD – PROGRAMMING SYSTEM SETPOINTS

9. Enter setpoints as detailed below. If you make a mistake when entering a value, press **CANCEL** key and then **ENTER** key. The display will revert to the default values and the cursor will return to the first changeable digit. You can then proceed to enter the correct values. If the entered value exceeds acceptable limits, **OUT OF RANGE – TRY AGAIN!** message will be displayed for 2 seconds, then the **PROGRAM MODE, SELECT SETPOINT** message will reappear.
10. When all the desired setpoints have been entered, press the **ACCESS CODE** key to exit **PROGRAM** mode and terminate access to **PROGRAM** mode. **ACCESS TO PROGRAM MODE DISABLED** is displayed. The Control Center will automatically return to **LOCAL, REMOTE** or **SERVICE** mode whichever was last selected.

To enter **CHILLED LIQUID TEMP** Setpoint: (Refer to Fig. 6.)

1. Press and release **CHILLED LIQUID TEMP** setpoint key. The following program prompt message will be displayed:

LEAVING SETPOINT = XX.X °F (BASE)

(BASE) refers to the base or lowest setpoint available to an Energy Management System. If any Energy Management System is applied, this value must be entered into the Energy Management System. Refer to previous explanation or **REMOTE/RESET TEMP RANGE**, page 11.

2. Use **ENTRY** keys to enter desired value.
3. Press and release **ENTER** key.

PROGRAM MODE, SELECT SETPOINT message is displayed.

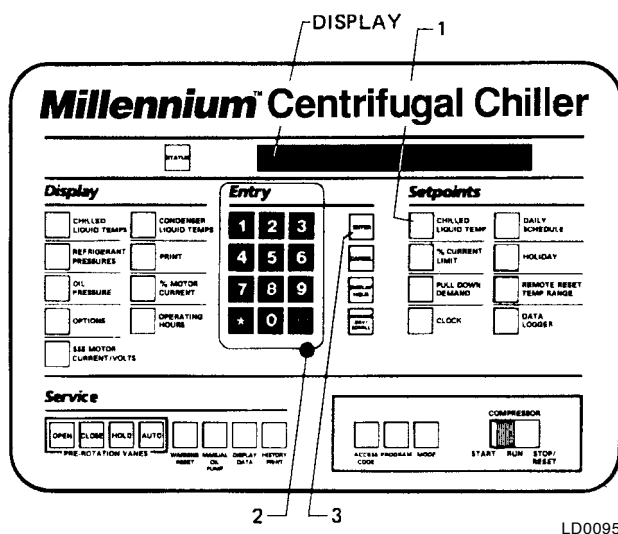

FIG. 6 – KEYPAD – PROGRAMMING “LEAVING CHILLED WATER TEMP” SETPOINT

To Enter **% CURRENT LIMIT** Setpoint: (**Electro-Mechanical Starter**, refer to Fig. 7)

1. Press and release **% CURRENT LIMIT** setpoint key. The following program prompt message is displayed:

CURRENT LIMIT = XXX% FLA

2. Use **ENTRY** keys to enter desired value.
3. Press and release **ENTER** key.

PROGRAM MODE, SELECT SETPOINT message is displayed.

(**Solid State Starter**, refer to Fig. 7)

1. Press and release **% CURRENT LIMIT** setpoint key. The following program prompt message is displayed:

CURRENT LIMIT = XXX% FLA; MTR CUR = _ _ _ FLA

2. Use **ENTRY** keys to enter desired value.
- NOTE: Motor Current FLA value is entered by YORK factory and checked at system start-up. It cannot be changed without special access code. (Note to service technician: refer to “Programming Instructions” in Service instruction, Form 160.49-M3.

3. Press and release **ENTER** key.
- PROGRAM MODE, SELECT SETPOINT** message is displayed.

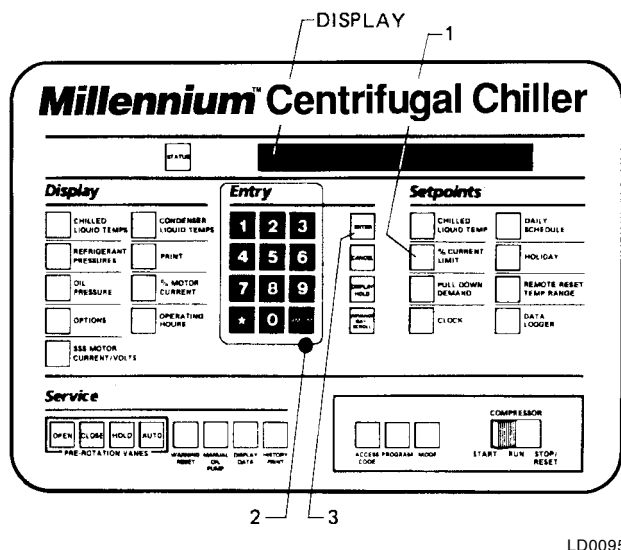

FIG. 7 – KEYPAD – PROGRAMMING “% CURRENT LIMIT” SETPOINT

To Enter **PULL DOWN DEMAND** Setpoint:
(Refer to Fig. 8.)

1. Press and release **PULL DOWN DEMAND** setpoint key. The following program prompt message is displayed:

SETPOINT = XXX MIN @ XXX % FLA, XXX MIN LEFT

2. Use **Entry** keys to enter desired values. For explanation, see **PULL DOWN DEMAND**, page 12. Note that “XX min left” is not an operator entered value.
3. Press and release **ENTER** key.

PROGRAM MODE, SELECT SETPOINT
message is displayed.

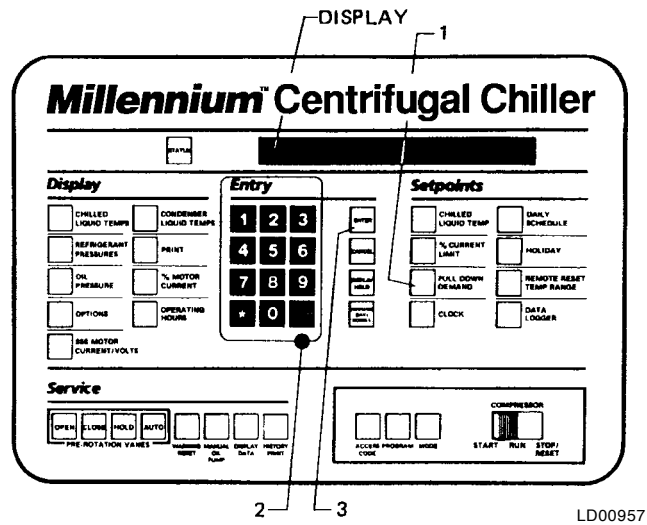

FIG. 8 – KEYPAD – PROGRAMMING “PULL DOWN DEMAND” SETPOINT

To Enter **CLOCK** Setpoint: (Refer to Fig. 9.)

1. Assure Micro Board Program jumper J57 is in “CLKON” position.
2. Press and release **CLOCK** setpoint key. The following program prompt message is displayed:

TODAY IS MON 10:30 PM 1/1/92

3. Press **ADVANCE DAY / SCROLL** key until the program per day of week appears on the display.
4. Use **Entry** keys to enter proper time of day.
5. Press **AM/PM** key to change the AM to PM or vice versa.
6. Use **Entry** keys to enter proper calendar date, (MONTH/DAY/YR). If month and day are single digit entries, precede the entry with “0”. For example, 02/04/88.
7. Press and release **ENTER** key.

PROGRAM MODE, SELECT SETPOINT
message is displayed.

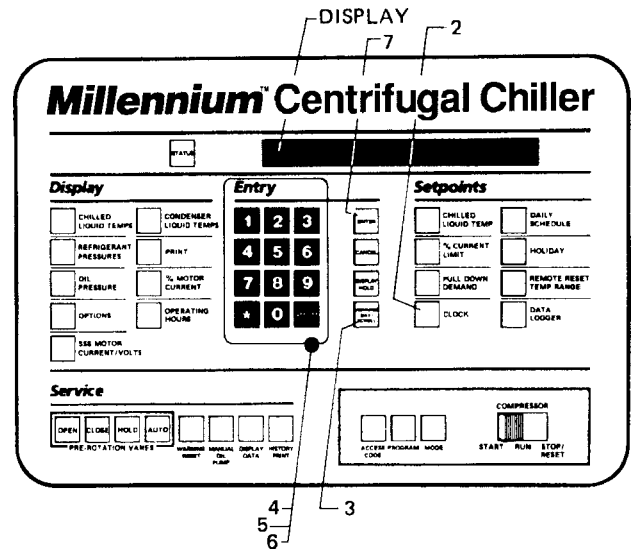

FIG. 9 – KEYPAD – PROGRAMMING “CLOCK” SETPOINT

To Enter **DAILY SCHEDULE** Setpoint:
(Refer to Fig. 10.)

1. Press and release **DAILY SCHEDULE** setpoint key.
The following prompt message is displayed:

SUN START = XX:XX AM, STOP = XX:XX AM

2. If the displayed start and stop time is not the desired schedule, enter the desired start and stop times as follows:
 - a. If you do not want the chiller to automatically start and stop on this day, press **CANCEL** key.
 - b. Use the **Entry** keys to enter desired hours and minutes start time.
 - c. If necessary, press the **AM/PM** key to change “AM” to “PM” or vice versa.
 - d. Use the **Entry** keys to enter desired hours and minutes stop time.
 - e. If necessary, press the **AM/PM** key to change “AM” to “PM” or vice versa.

3. Press and release **ADVANCE DAY/SCROLL** key. The following prompt message is displayed:

MON START = XX:XX AM, STOP = XX:XX AM

4. Enter the desired start and stop time per Step 2.
5. Press and release **ADVANCE DAY/SCROLL** key. The following prompt message is displayed:

REPEAT MON SCHEDULE MON-FRI? YES = 1; NO = 0

- a. If you press the **1 Entry** key, Monday’s start and stop time will be automatically entered for Tuesday through Friday.

– or –

- b. If you press the **0 Entry** key, Tuesday through Friday can be programmed with different start and stop times.

6. Use the **ADVANCE DAY / SCROLL** key with procedure in Step 2. To enter start and stop times for remainder of the week plus a holiday schedule if required.

7. Press the **ENTER** key.

PROGRAM MODE, SELECT SETPOINT is displayed.

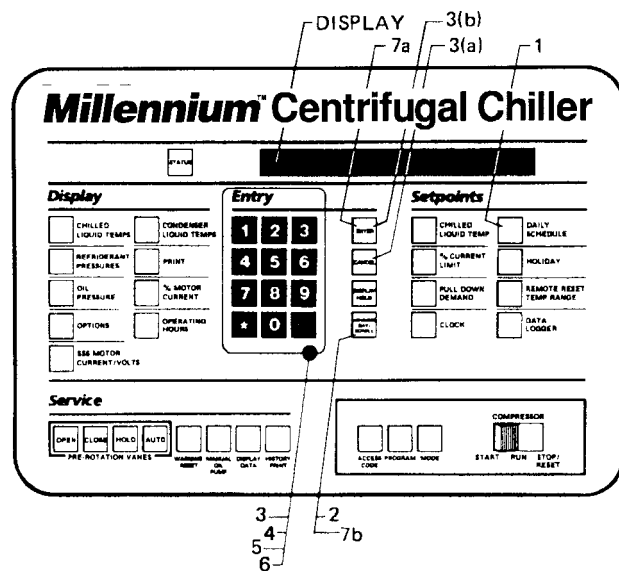

LD00959

FIG. 10 – KEYPAD – PROGRAMMING “DAILY SCHEDULE” SETPOINT

To Enter **HOLIDAY** Setpoint: (Refer to Fig. 11.)

1. Press and release **HOLIDAY** setpoint key. The following program prompt message is displayed:

S _ M _ T _ W _ T _ F _ S _ HOLIDAY NOTED BY *

2. Press and release **ADVANCE DAY/SCROLL** key to move cursor to the day that you wish to designate as a holiday.

3. Press and release * entry key. An * will appear next to the selected day.

4. After you have placed an * next to each of the days that you wish to designate a holiday, press **ENTER** key PROGRAM MODE, SELECT SETPOINT message is displayed.

To cancel all of the designated holidays: perform Step 1, press **CANCEL** key, and then press **ENTER** key.

PROGRAM MODE, SELECT SETPOINT message is displayed.

To cancel one of the designated holidays: perform Step 1, press **ADVANCE DAY / SCROLL** key until the cursor appears to the right of the desired day, press the * key, then press the **ENTER** key.

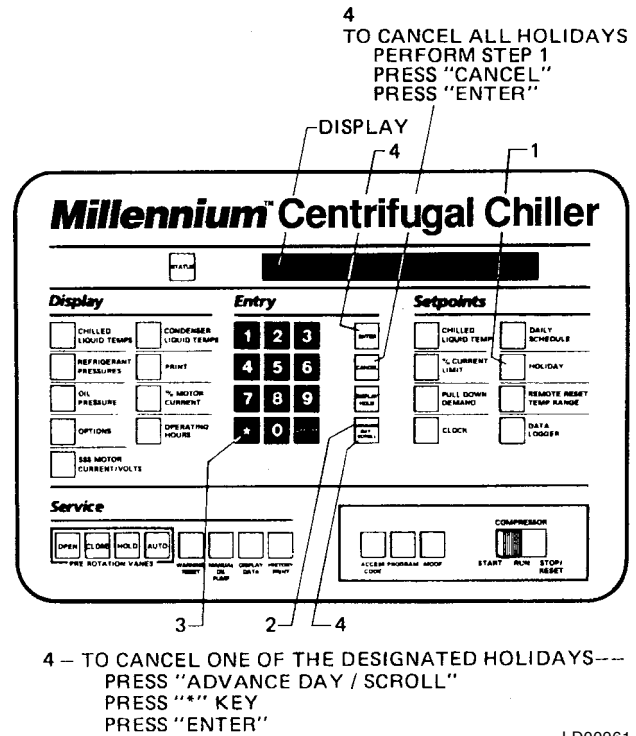

FIG. 11 – KEYPAD – PROGRAMMING “HOLIDAY” SETPOINT

LD00961

To Enter **REMOTE/ RESET TEMP RANGE** Setpoint: (Refer to Fig. 12.)

1. Press and release **REMOTE/RESET TEMP RANGE** setpoint key. The following program prompt message is displayed:

REMOTE TEMP SETPOINT RANGE = XX °F

2. Use **Entry** keys desired value (10 or 20).

3. Press and release **ENTER** key.

PROGRAM MODE, SELECT SETPOINT message is displayed.

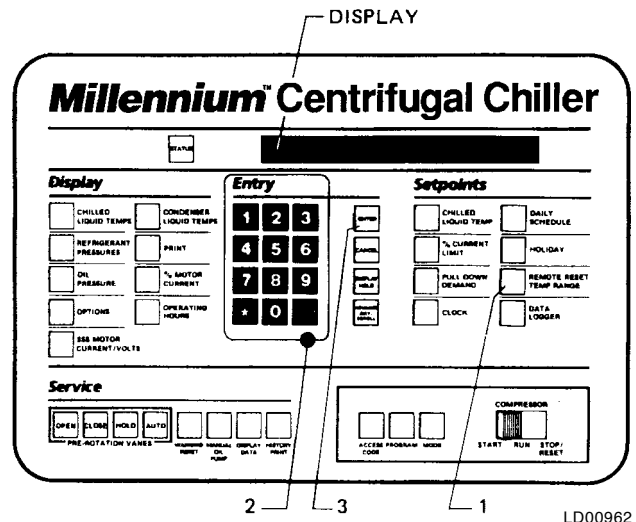

FIG. 12 – KEYPAD – PROGRAMMING “REMOTE RESET” TEMP RANGE

LD00962

To Enter **DATA LOGGER** Setpoint:

Refer to Form 160.49-N7 for operation of this key.

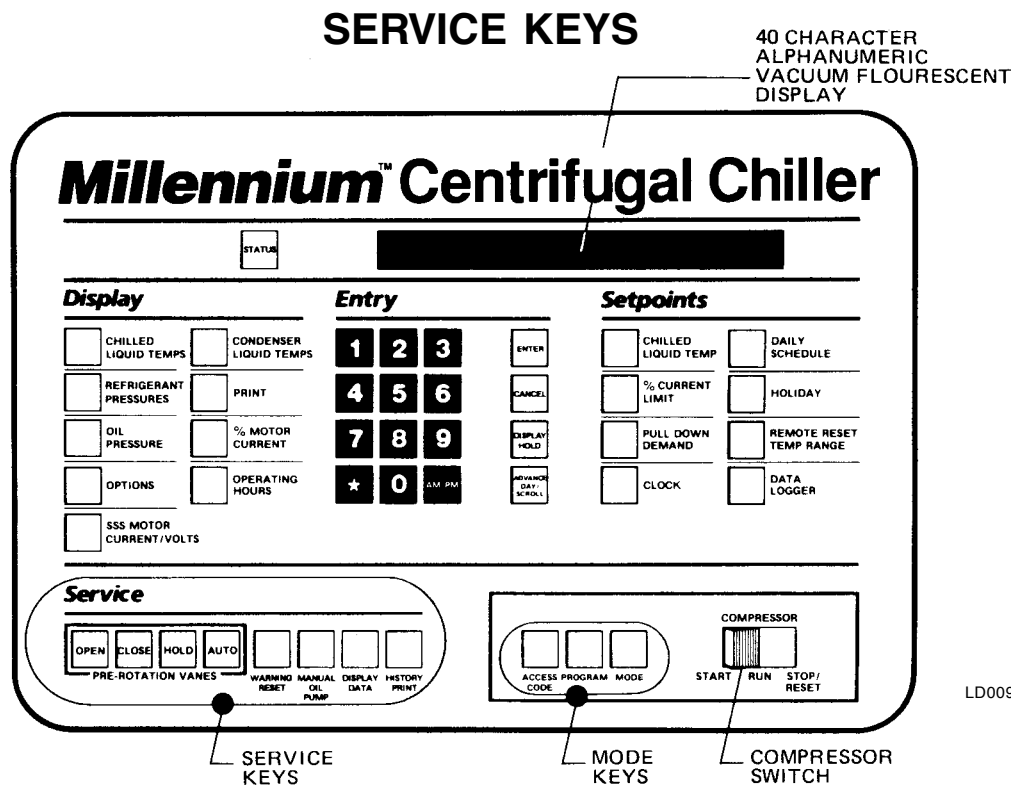

FIG. 13 – KEYPAD – SERVICE KEYS LOCATION

The **Service** keys are provided for the service technician's use when performing routine maintenance or when troubleshooting the system. The **WARNING RESET** and **PRE-ROTATION VANES** keys are enabled in **SERVICE** mode only. The remainder of the **Service** keys are enabled in **SERVICE**, **LOCAL** or **REMOTE** mode.

PRE-ROTATION VANES KEYS

If chiller is equipped with the REFRIGERANT LEVEL CONTROL (and EPROM version C.02F(T).13 or later), the pre-rotation vanes keys can be used to manually control the refrigerant level variable orifice or the pre-rotation vanes. The procedure to select either manual vane or manual variable orifice control is contained in "Special Setpoints and Programming Procedures" section of Service manual, Form 160.49-M3 and must be performed by a qualified service technician only.

OPEN – Press and release this key to drive the pre-rotation vanes open. If the chiller is running, **SYSTEM RUN – VANES OPENING** is displayed. If chiller is not running, **SYS READY TO START – VANES OPENING** is displayed. The vanes will continue to open until the **CLOSE**, **HOLD**, or **AUTO** (if temperature error requires it) keys are pressed and released.

HOLD – Press and release this key to hold the pre-rotation vanes in their present position. If the chiller is

running, **SYSTEM RUN – VANES HOLDING** is displayed. If chiller is not running, **SYS READY TO START – VANES HOLDING** is displayed. The vanes will remain stationary until the **OPEN**, **HOLD**, or **AUTO** keys are pressed and released.

AUTO – Press and release this key to put the pre-rotation vanes under LCWT control as long as the current limit setpoint is not reached, which causes the current limit function to override the LCWT control. If system is running, **SYSTEM RUN – AUTO VANES** is displayed. The actual opening and closing of the vanes is indicated on the display. When the vanes are opening, **SYSTEM RUN – VANES OPENING** is displayed. If the vanes are closing, **SYSTEM RUN – VANES CLOSING** is displayed. Whenever the Control Center is in **LOCAL**, **REMOTE** or **PROGRAM** mode, the vane control circuitry is automatically placed in **AUTO** mode and the vanes operate to control the leaving chilled water temperature to the programmed setpoint.

CLOSE – Press and release this key to drive the pre-rotation vanes closed. If the chiller is running, **SYSTEM RUN – VANES CLOSING** is displayed. If chiller is not running, **SYS READY TO START – VANES CLOSING** is displayed. When the vanes are full closed, **SYS READY TO START – VANES CLOSED** is displayed. The vanes will continue to close until the **OPEN**, **HOLD**, or **AUTO** keys are pressed.

OTHER SERVICE KEYS

WARNING RESET – Press and release this key to reset any “WARNING” or “STATUS” message that can be reset with this key, unless the condition still exists. To reset any cycling or warning message, place the Control Center in **SERVICE** mode and press **WARNING RESET** key. To reset any safety shutdown message, press **WARNING RESET** key in **SERVICE** mode with the **COMPRESSOR** switch in the **STOP/RESET** position.

MANUAL OIL PUMP – This key is operational in any mode. Press and release this key to run the oil pump. Press and release the key again to stop the oil pump. A 10-minute maximum is imposed on the running of the oil pump (i.e., the oil pump will automatically shut off after 10 minutes). If a longer running time is desired, the key must be pressed again. The manual oil pump feature is disabled during “START SEQUENCE INITIALIZED” to allow for auto-zeroing of oil pressure transducers.

DISPLAY DATA – This key is operational in any three of the Control Center modes of operation (**SERVICE**, **LOCAL** or **REMOTE**). It is used to display certain system operating parameters that are relevant to troubleshooting the chiller system.

Press and the **DISPLAY DATA** key. The following messages will sequentially scroll on the display. Each message will be displayed for 2 seconds.

Messages 1 and 2 are only displayed if unit is equipped with EPROM version C.02F(T).13 or later and Refrigerant Level Control has been enabled by a qualified service technician using the “Special Setpoints and Programming” procedures section of Service manual, Form 160.49-M3.

NO. 1

MANUAL VANE OPERATION ALLOWED – Displayed when the **PRE-ROTATION VANES** service keys have been selected for manual VANE control. This allows these keys to manually control the vanes in **Service** mode. The procedure to select manual vanes control is in Service manual, Form 160.49-M3 and should be performed only by a qualified service technician.

– or –

NO. 1

MANUAL LEVEL CONTROL ALLOWED – Displayed when the **PRE-ROTATION VANES** keys have been selected for manual REFRIGERANT LEVEL control. This allows these keys to manually control the refrigerant level control variable orifice in **Service** mode. When manual refrigerant level control is selected, the pre-rotation vanes **Service** keys cannot be used to control the vanes. The

procedure to select manual refrigerant level control is in Service manual, Form 160.49-M3 and should be performed only by a qualified service technician.

NO. 2

PULLDN LEVEL = XXX%; SETP = XXX%; ACTUAL = XXX% – Displayed when there is a refrigerant level setpoint pulldown (ramp) in effect. **PULLDN LEVEL** is the refrigerant level setpoint that is presently in effect. **SETP** is the refrigerant level setpoint that has been programmed by the service technician and **ACTUAL** is the refrigerant level in the condenser. The pulldown period is 15 minutes in duration. During the pulldown period, a linearly increasing ramp is applied to the level setpoint. This causes the setpoint to increase from 0% to the programmed value over a period of 15 minutes. After the 15 minutes have elapsed, the setpoint remains the programmed value and this message is replaced by the message **ACTUAL = XXX%; LEVEL SETP = XXX%** as described below.

A refrigerant level setpoint pulldown is put into effect when the vanes are driven from a fully closed to an open position, if the actual refrigerant level is less than the level setpoint when the vane motor end switch (VMS) opens. If the actual level is greater than the setpoint when the VMS opens, the level is controlled to the programmed setpoint. Whenever the vanes go to the fully closed position (VMS closed), any pulldown that is in effect is cancelled.

– or –

NO. 2

ACTUAL LEVEL = XXX%; LEVEL SETP = XXX% – Displays the actual refrigerant level in the condenser and the refrigerant level setpoint programmed by the service technician. This message replaces the previous message after a refrigerant level setpoint pulldown period terminates.

NO. 3

SAT TEMPS EVAP = XX.X°F; COND = XX.X°F – This is the refrigerant saturation temperatures for the evaporator and condenser.

NO. 4

DISCHARGE TEMP = XXX.X°F; OIL TEMP = XXX.X°F

NO. 5

HOP = XX.X PSIG; LOP = XX.X PSIG – This is the low oil pressure (LOP) as measured at the oil sump and the high oil pressure (HOP) as measured at the compressor bearing input.

NO. 6

ACTUAL POS = XX MILS; REF = YY MILS – **ACTUAL POS** is the distance between the high speed thrust collar and the proximity probe that is used to measure the position. **REF** is the reference position established at time of compressor manufacture.

NO. 7

HIGH SPEED DRAIN TEMP = XXX.X °F – Temperature of oil in high speed drain line.

To hold any of the above messages, press the **DISPLAY DATA** key, then press the **DISPLAY HOLD** key. The message will be displayed and updated every 2 seconds until the **DISPLAY DATA** key is pressed again, whereupon the next message is displayed. To return to the normal foreground messages, press the **DISPLAY HOLD** key.

HISTORY PRINT – This key is used to initiate a history print to the optional printer. Refer to Form 160.49-N7 for operation of this key.

OPERATING MODES

The MicroComputer Control Center can be operated in four different operating modes as follows:

SERVICE – enables all the **Service keys** except **DISPLAY DATA**, **MANUAL OIL PUMP**, and **HISTORY PRINT**, which are enabled in all modes. See “Service Keys”, page 20.

LOCAL – This is the normal operating mode. The compressor can be started and stopped from the Control Center. Also, the **Display** and **Setpoints** parameters can be displayed.

PROGRAM – Allows the operator to program the **Setpoints** parameters, and change operating modes.

REMOTE – In this mode, the Control Center will accept control signals from a remote device (i.e., Energy Management System) or cycling input. The control signal inputs are:

1. Remote Start
2. Remote Stop
3. Remote LCWT Setpoint
4. Remove Current Limit Setpoint

NOTE: The compressor can be stopped by the **COMPRESSOR** switch, regardless of the operating mode. The switch must be in **RUN** position to enable **REMOTE** mode. The operator cannot locally start the compressor using the **COMPRESSOR** switch when in the **REMOTE** mode.

To determine which operating mode the Control Center is presently in, simply press the **MODE** key.

- If the Control Center is in **LOCAL** mode, **LOCAL OPERATING MODE IN EFFECT** is displayed.
- If the Control Center is in **REMOTE** mode, **REMOTE OPERATING MODE IN EFFECT** is displayed.
- If the Control Center is in **SERVICE** mode, **SERVICE OPERATING MODE IN EFFECT** is displayed.

To change operating mode, proceed as follows:

1. Press **ACCESS CODE** key.
2. **ENTER VALID ACCESS CODE _ _ _ _** is displayed.
3. Using **Entry** keys, enter **9 6 7 5**.
4. As each digit is entered, the characters **Y O R K** are displayed.
NOTE: If digits other than **9 6 7 5** are entered, **Y O R K** is still displayed.
5. Press **ENTER** key.
NOTE: If digits other than **9 6 7 5** were entered in step No. 4, **INVALID ACCESS CODE** is displayed when the **ENTER** key is pressed. If this occurs, enter the correct access code (**9675**) and proceed.
6. **ACCESS TO PROGRAM KEY AUTHORIZED** is displayed.

NOTE: Unless terminated by pressing the **ACCESS CODE** key again, the operator will have access to the **PROGRAM** key for 10 minutes. When 10 minutes have elapsed, access to **PROGRAM** key will be automatically disabled and the operator must return to step No. 1 to gain access.

7. Press **PROGRAM** key.
8. **PROGRAM MODE, SELECT SETPOINT** is displayed.
9. Press **MODE** key.
10. The mode that has been previously selected will be displayed as follows:
 - LOCAL MODE SELECTED**
 - or –
 - SERVICE MODE SELECTED**
 - or –
 - REMOTE MODE SELECTED**
11. Press **ADVANCE DAY** key to scroll to desired mode. Each time this key is pressed, a different mode is displayed as above:
12. When the desired mode is displayed, press **ENTER** key.
13. **PROGRAM MODE, SELECT SETPOINT** is displayed.
14. Press **ACCESS CODE** key to exit **PROGRAM** mode and terminate access to **PROGRAM** mode.
15. **ACCESS TO PROGRAM MODE DISABLED** is displayed.

COMPRESSOR SWITCH

(See Fig. 13, page 19.)

This rocker switch is used to locally operate the compressor. It is used to start, run and stop the compressor. Also, it resets the Control Center after a safety shutdown.

To **START*** chiller compressor in **LOCAL** mode:

Move **COMPRESSOR** switch from **STOP/RESET** to **START** position. Switch will spring-return to **RUN** position.

To **STOP** compressor:

Move switch from **RUN** to **STOP/RESET** position.

To **RESET** Control Center:

Following a safety shutdown, the operator is required to reset the Control Center prior to restarting the system. Move switch from **RUN** to **STOP/RESET** position.

*NOTE: The operator cannot start the compressor (using this switch) when the Control Center is in **REMOTE** mode.

DISPLAY MESSAGES

The following displayed messages will be automatically displayed unless the operator is requesting additional information via the keypad.

SYSTEM RUN - CURRENT LIMIT IN EFFECT

Displayed when the chiller is running, and the motor current is equal-to or greater-than the operator-programmed “XXX % FLA” current limit value. When the motor current reaches 100% of this value, the pre-rotation vanes are not permitted to open further. If the current continues to rise to 104% of this value, the vanes will be driven closed – not fully closed; only far enough to allow the current to decrease to a value less

than 104% of the operator-programmed “XXX % FLA” current limit.

For example:

With the operator-programmed “% CURRENT LIMIT” set at 50% and the FLA of the chiller equal to 200A, the current limit circuit would perform as follows:

(100%) (50% x FLA) = Vanes inhibited from opening further.

(104%) (50% x FLA) = Vanes driven toward close position.

Therefore:

(100%) (50% x 200) = 100A = Vanes stop opening

(104%) (50% x 200) = 104A = Vanes driven toward close position.

SYSTEM RUN – AUTO VANES

Displayed when the chiller is running, the MicroComputer Control Center is in **SERVICE** mode, and the vanes are operating in **AUTO** mode.

SYSTEM RUN – VANES OPENING

Displayed when the chiller is running, the MicroComputer Control Center is in **SERVICE** mode with:

- The vanes operating in **AUTO** mode and opening to maintain the leaving chilled water temperature setpoint.
- or –
- The operator has pressed the vanes **OPEN** key on the keypad.

SYSTEM RUN – VANES CLOSING

Displayed when the chiller is running, the MicroComputer Control Center is in **SERVICE** mode with:

- The vanes operating in **AUTO** mode and closing to maintain the leaving chilled water temperature setpoint.
- or –
- The operator has pressed the vanes **CLOSE** key on the keypad.

SYSTEM RUN – VANES HOLDING

Displayed when the chiller is running, the MicroComputer Control Center is in **SERVICE** mode, and the operator has pressed the vanes **HOLD** key.

SYS READY TO START – VANES OPENING

Displayed when the chiller is running and the operator has pressed the vanes **OPEN** key on the keypad.

SYS READY TO START – VANES CLOSING

Displayed when the chiller is not running and the operator has pressed the vanes **CLOSE** key on the keypad.

SYS READY TO START – VANES HOLDING

Displayed when the chiller is running and the operator has pressed the vanes **HOLD** key on the keypad.

SYSTEM RUN – LEVEL VALVE OPENING

Displayed as a foreground message when manual refrigerant level control has been selected using the “Special Setpoints Procedure” in Service manual, Form 160.49-M3 and operating in **SERVICE** mode. Indicates an “OPEN” command is being output to the variable orifice. Manual level control should be selected only by a qualified service technician.

SYSTEM RUN – LEVEL VALVE CLOSING

Displayed as a foreground message when manual refrigerant level control has been selected using the “Special Setpoints Procedure” in Service manual, Form 160.49-M3 and operating in **SERVICE** mode. Indicates a “CLOSE” command is being output to the variable orifice. Manual level control should be selected only by a qualified service technician.

SYSTEM RUN – AUTO LEVEL CONTROL

Displayed as a foreground message when manual refrigerant level control has been selected using the “Special Setpoints Procedure” in Service manual, Form 160.49-M3 and operating in **SERVICE** mode. Indicates that neither a “CLOSE” nor “OPEN” command is being output to the variable orifice but is in “AUTO” mode. Manual level control should be selected only by a qualified service technician.

SYSTEM RUN – LOW PRESSURE LIMIT IN EFFECT

Displayed when the chiller is running and the evaporator pressure falls to 56.2 PSIG (R-22); 27 PSIG (R-134a). Simultaneously, the pre-rotation vanes will be prevented from further opening. This action maintains chiller operation to prevent low-evaporator-pressure shutdown at 54.3 PSIG (R-22); 25 PSIG (R-134a). When the evaporator pressure rises to 57.5 PSIG (R-22); 28 PSIG (R-134a), the vanes will be permitted to open. Low pressure limit feature is not used when program jumper (JP3) is cut (Brine application).

SYSTEM RUN – HIGH PRESSURE LIMIT IN EFFECT

Displayed when the chiller is running and the condenser pressure rises to 246.3 PSIG (R-22); 162.5 PSIG (R-134a). Simultaneously, the pre-rotation vanes will be inhibited from further opening. This action occurs to prevent system shutdown on high condenser pressure

at 265 PSIG (R-22); 180 PSIG (R-134a). When the condenser pressure falls to 245 PSIG (R-22); 160 PSIG (R-134a), the vanes will be permitted to open.

SYSTEM RUN – PRESSURE STATUS

Displayed when the chiller is running. It instructs the operator to press the **STATUS** key, whereupon one of the following messages will be displayed:

- **WARNING: COND OR EVAP TRANSDUCER ERROR**

Indicates a probable condenser or evaporator transducer problem, because the output is unreasonable. The microprocessor arrives at this conclusion by subtracting the evaporator transducer output from the condenser transducer output. The result must be zero or some positive number. If the result is a negative number, it concludes that there is a probable condenser or evaporator transducer problem. This function is inhibited for the first 10 minutes of chiller run-time, and is checked every 10 minutes thereafter. Message is reset by pressing the **WARNING RESET** key in the **Service** mode.

NOTE: If the **STATUS** key is arbitrarily pressed, without the operator being prompted by the **PRESS STATUS** message, the following message shall be displayed.

NO MALFUNCTION DETECTED

WARNING – REFRIGERANT LEVEL OUT OF RANGE

Displayed when the refrigerant level sensor output goes to > 4.4VDC. While this is displayed, the variable orifice is driven open until the level is within range. This message is automatically cleared when output is within range.

SYSTEM RUN – LEAVING TEMP CONTROL

Displayed while the chiller is running. Indicates that the pre-rotation vanes are being controlled by the leaving chilled water temperature (LCWT). This is the normal mode of chiller operation. Thus, if the LCWT is above the setpoint, but pulling down rapidly, the vanes will pulse closed as the LCW nears the setpoint.

SYSTEM READY TO START

Indicates that the system is not running, but will start upon application of a start signal.

SYSTEM SHUTDOWN – PRESS STATUS

Displayed when chiller is shut down on a cycling shutdown, safety shutdown (operator must move the **COMPRESSOR** switch to **STOP/RESET** in order to restart) or operator-initiated shutdown (within 30 minutes of

initial start-up). The status message consists of the day and time of shutdown, cause of shutdown, and type of restart required. Upon pressing **STATUS** key, System Shutdown Message will be displayed for 2 seconds and then return to

SYSTEM SHUTDOWN – PRESS STATUS

Display can be held indefinitely by depressing **DISPLAY** key. For examples of System Shutdown Messages, see below.

SYSTEM SHUTDOWN MESSAGES

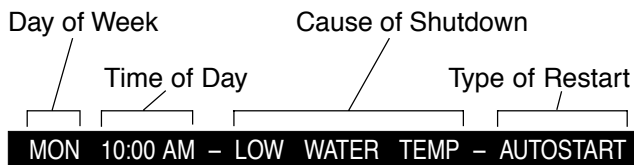

Chiller was shut down on Monday at 10:00 AM because the LCWT has decreased to a value that is 4°F below the operator-programmed chilled liquid temperature setpoint. However, if the setpoint is less than 40°F, the chiller will always shut down at 36°F. Further, if the chiller is running and the setpoint is changed, the (Low Water Temperature) cutout will be 36°F for 10 minutes in order to eliminate nuisance trips. Finally, for brine chilling applications, the LWT cutout is always 4°F below the setpoint. (The water jumper on the Micro Board must be removed for a brine unit.)

MON XX:XX AM – FLOW SWITCH – AUTOSTART

Chiller is shut down because a chilled-liquid flow switch has opened. The flow switch must open for a minimum of 2 seconds in order to cause a shutdown. The flow switch is checked 25 seconds into “Start Sequence Initiated” and continuously thereafter.

MON XX:XX AM – SYSTEM CYCLING – AUTOSTART

A remote command (computer relay contact or manual switch) connected to the Remote/Local cycling input of the digital input board has shut down the chiller.

MON XX:XX AM – MULTI UNIT CYCLING – AUTOSTART

Lead/Lag sequence control accessory has shut down the chiller.

MON XX:XX AM – POWER FAILURE – AUTOSTART

The chiller is shut down because there has been a power interruption or failure. The chiller will automatically restart when power is restored. This message

will be displayed if the Micro Board is configured for **AUTO-RESTART AFTER POWER FAILURE**. The Micro Board is factory set for manual restart after power failure. To convert it to auto-restart after power failure, remove one of the two-pin program jumpers from the cloth bag located inside the Control Center and place it on the terminals labeled "Auto R" (J60) on the Micro Board.

MON XX:XX AM – POWER FAILURE

The chiller is shut down because there has been a power interruption or failure. When power is restored, the chiller can be restarted by pressing the **COMPRESSOR** switch to **STOP/RESET** position and then to **START** position. This message will be displayed if the Micro Board is configured for **MANUAL RESTART AFTER POWER FAILURE**. The Micro Board is factory set for manual restart after power failure. This has been accomplished by removing the two-pin jumper from the terminals labeled "Auto R" (J60) on the Micro Board.

AC UNDERVOLTAGE – AUTOSTART

The chiller is shut down because the MicroComputer Control Center was in **RUN** mode, displaying **SYSTEM RUN – LEAVING TEMP CONTROL**, but the motor current was less than 10% FLA for 25 continuous seconds. This is indicative of an AC undervoltage condition that has caused the start relay (1R) in the Micro-Computer Control Center to de-energize. This condition is checked when the MicroComputer Control Center goes into **RUN** mode (after 30 second pre-lube). This condition can be caused by failure of any component that would cause a loss of the start signal from the Control Center. In essence, this check assures that the compressor is running when the Control Center is displaying

SYSTEM RUN – LEAVING TEMP CONTROL

This check is not performed when program jumper JP4 is removed (Steam Turbine applications).

MON XX:XX AM – INTERNAL CLOCK – AUTOSTART

The operator-programmed daily stop schedule has shut down the chiller. The chiller will automatically restart when the operator-programmed daily start schedule indicates a start. It can be overridden by pressing the **COMPRESSOR** switch to the **START** position.

REMOTE STOP

This message will be displayed when a remote device (typically an Energy Management System) has commanded the chiller to shut down. The chiller will restart upon application of a separate start signal from the remote device. This message will only be displayed

when Control Center is in **REMOTE** mode.

ANTI-RECYCLE, XX MIN LEFT

The chiller may not restart more frequently than every 30 minutes. Displayed when chiller is shut down and there is time remaining on the anti-recycle timer. In normal operation, chiller cannot be restarted until **ANTI-RECYCLE, 00 MIN LEFT** is displayed. However, when servicing the chiller, it may be desirable to inhibit this 30-minute timer. If so, simply install a jumper plug in the unmarked terminals of the Micro Board directly under Auto-Restart jack.

This feature eliminated when program jumper JP4 is removed (Steam Turbine applications).

WARNING: Remove this jumper after servicing. Failure to do this voids the Warranty.

MON XX:XX AM – LOW EVAP PRESSURE

The chiller is shut down because the evaporator pressure has decreased to 54.3 PSIG (R-22); 25.0 PSIG (R-134a). The chiller will be allowed to start when the pressure increases to 54.4 PSIG (R-22); 25.1 PSIG (R-134a). To restart chiller, press the **COMPRESSOR** switch to the **STOP/RESET** position and then to the **START** position.

MON XX:XX AM – LOW EVAP PRESSURE – BRINE

The chiller is shut down because the brine Low Evaporator Pressure (LEP, not included with standard Control Center) safety contacts have opened. The brine LEP safety is located external to the Control Center. Safety cut-out settings will vary with the brine application. To restart the chiller, wait until the safety contacts close, press the **COMPRESSOR** switch to the **STOP/RESET** position and then to the **START** position.

MON XX:XX AM – LOW OIL PRESSURE

The chiller is shut down because the oil pressure has decreased to 15 PSID while running, or never achieved 25 PSID prior to compressor start during the oil pump pre-lube run. The chiller will be allowed to restart when the pressure increases to 25 PSID. Differential pressure is sensed by two pressure transducers. To restart chiller, press **COMPRESSOR** switch to **STOP/RESET** position and then to the **START** position.

MON XX:XX AM – HIGH PRESSURE

The chiller is shut down because condenser pressure

has increased to 265 PSIG (R-22); 180 PSIG (R-134a). System will be allowed to restart when pressure decreases to 205 PSIG (R-22); 120 PSIG (R-134a). Pressure is sensed by a High Pressure (HP) safety control that is located on a mounting bracket above the oil-pump starter located on the condenser. This message is prompted by the opening of the HP safety control contacts. To restart chiller, press **COMPRESSOR** switch to the **STOP/RESET** position and then to the **START** position.

MON XX:XX AM – EVAP TRANS OR PROBE ERROR

The chiller is shut down because the leaving chilled water temperature minus the evaporator saturation temperature is outside the range of -2.5°F to $+25^{\circ}\text{F}$ continuously for 10 minutes. To restart the chiller, press **COMPRESSOR** switch to **STOP/RESET** switch to **STOP/RESET** position and then to **START** position. On Brine applications (program jumper JP3 removed), this check is not performed when the evaporator transducer is reading a pressure below its “out-of-range” threshold.

On Steam Turbine applications (Micro Board program jumper JP4 removed), with EPROM version C.02F (T).12 or later, this check is bypassed for the first 20 minutes of chiller run time and then performed at the regular 10 minute intervals thereafter. This is to allow for the additional time required to decrease the evaporator pressure due to the longer acceleration time of the steam turbine.

MON XX:XX AM – MOTOR CONTROLLER – EXT. RESET

The chiller is shut down because a current module (CM-2 Electro-Mechanical starter application), or the YORK Solid State Starter or the Variable Speed Drive initiated a shutdown. To restart system, reset the external device that caused the shutdown. The chiller will then automatically restart.

NOTE: The following motor controller shutdowns do not require an external reset to restart chiller.

Solid State Starter 110°F start inhibit. Anytime the chiller has been shut down for any reason, this message will be displayed until the SCR heatsink temperatures decrease to below 110°F .

MON XX:XX AM – POWER FAULT – AUTOSTART

The chiller is shut down because of a Solid State Starter or current module (CM-2 Electro-Mechanical starter application) “Power Fault” shutdown. The chiller will automatically restart. This function is sensed by the motor controller input to the digital input board. A power-fault shutdown is initiated by the motor controller contacts (CM-1) opening and reclosing in one second. If

Solid State Starter application, the shutdown could have been caused by any of the following reasons. The appropriate light on the Solid State Starter Logic Board will be illuminated.

- Phase rotation/loss
- Trigger Board out of lock (OOL)
- Power Fault
- Half Phase

MON XX:XX AM – HIGH DISCHARGE TEMP

The chiller is shut down because the discharge temperature has increased to 220°F . The system will be allowed to restart when the temperature has decreased to 219°F . Temperature is sensed by a thermistor RT2. To restart the chiller, press **COMPRESSOR** switch to **STOP/RESET** position and then to the **START** position.

MON XX:XX AM – HIGH OIL TEMP

The chiller is shut down because the oil temperature has increased to 180°F . The system will be allowed to restart when the temperature decreases to 179°F . The temperature is sensed by thermistor RT3. To restart the chiller, press **COMPRESSOR** switch to **STOP/RESET** position and then to the **START** position.

MON XX:XX AM – OIL PRESSURE TRANSDUCER

The chiller is shut down because the oil pressure has increased to 125 PSID (during the first 7 minutes of compressor operation) 60 PSID (after the first minutes of compressor operation). The chiller will be allowed to restart when the oil pressure decreases to 59 PSID. To restart the chiller, press **COMPRESSOR** switch to **STOP/RESET** position and then to the **START** position.

MON XX:XX AM – FAULTY COND PRESSURE XDCR

The chiller is shut down because the condenser transducer is indicating a pressure of less than 24.2 PSIG (R-22), 6.8 PSIG (R-134a); or a pressure greater than 300 PSIG (R-22 or R-134a). This is generally indicative of a defective condenser transducer or the transducer has been disconnected. After the problem has been corrected, the chiller can be restarted. To restart, press **COMPRESSOR** switch to **STOP/RESET** position and then to **START** position.

MON XX:XX AM – FAULTY OIL PRESSURE XDCR

The chiller is shut down because either the high side or low side oil pressure transducer was out-of-range (displaying x's) while chiller was running. To restart

chiller, press **COMPRESSOR** switch to **STOP/RESET** position and then to **START** position.

VANE MOTOR SWITCH OPEN

The chiller is shut down because a system-start sequence has been initiated, but the pre-rotation vanes are not fully closed.

MON XX:XX AM – STARTER MALFUNCTION DETECTED

The chiller is shut down because the Control Center has detected a motor-current value greater than 15% FLA for 10 seconds minimum anytime when the compressor-start signal is not energized. To restart the chiller, press **COMPRESSOR** switch to **STOP/RESET** position and then to the **START** position.

MON XX:XX AM – PROGRAM INITIATED RESET

The chiller is shut down because Micro Board did not receive a hardware-generated interrupt on schedule. Typical is an Analog/Digital Converter interrupt. This message is indicative of a Micro Board hardware failure or electrical noise on Micro Board. The chiller will automatically restart. This message indicates that the watchdog timer-circuit has reset the microprocessor. This occurs when the time needed to step through program is longer than allowable, thus the software program is initialized at its beginning.

SYSTEM READY TO START – PRESS STATUS

The chiller was shut down on a safety shutdown and will start upon application of a local or remote start signal. Since the message states that the chiller is “Ready to Start”, it means that the shutdown no longer exists and the Control Center has been manually reset. When the **STATUS** key is pressed, a message is displayed that describes the reason for shutdown. The message will be displayed for 2 seconds and then return to **SYSTEM READY TO START – PRESS STATUS**.

Those messages that could be displayed are any of the previously described safety-shutdown messages or warning messages. They can be cleared from the display by entering **Service** mode and pressing **WARNING RESET** key. Or, the message will be cleared by initiating a compressor start.

START SEQUENCE INITIATED

Indicates that the Micro Board has received a local or remote start signal and has initiated the chiller start-up routine.

This is the compressor pre-lube period. The duration of this period is controlled by the “Prerun” (JP6) wire

jumper on the Micro Board as follows:

FUNCTION	JUMPER POSITION
50 Sec. Oil Pump Prerun	Installed
180 Sec. Oil Pump Prerun	Cut

SYSTEM COASTDOWN

Displayed while motor is decelerating after a chiller shutdown. The oil pump is running during this period. The duration of this period is 150 seconds.

If unit is configured for a Steam Turbine application (program jumper JP4 removed), this period is extended to allow for a longer coastdown time. EPROM version C.02F(T).11 provides a 6 minute coastdown period. EPROM version C.02F(T).12 or later provides a 10 minute coastdown period.

MON XX:XX AM – MTR PHASE CURRENT UNBALANCE

(Solid State Starter applications only)

The chiller is shut down because the compressor-motor current was unbalanced while the chiller was running. The current balance is only checked after the motor has been running for a minimum of 45 seconds and the motor current is 80% FLA or greater. If the current in any phase deviates from the average $(\frac{a + b + c}{3})$ current by greater than 30% for a minimum of 45 consecutive seconds, a shutdown is initiated. To restart the system, press the **COMPRESSOR** switch to **STOP/RESET** position and then to the **START** position. An example of the conditions for shutdown is as follows:

IF:

$$I_{\phi A} = 200A$$

$$I_{\phi B} = 200A$$

$$I_{\phi C} = 118A$$

THEN:

$$I_{AV} = \frac{200 + 200 + 118}{3}$$

$$I_{AV} = 173A$$

$$I_{ACCEPTABLE} = 173 \pm 30\% = 121A \text{ or } 225A$$

THEREFORE:

Since $I_{\phi C} = 118A$ which is less than the acceptable 121A, the chiller would shut down if this unbalance exists for 45 consecutive seconds.

MON XX:XX AM – LOW LINE VOLTAGE

(Solid State Starter applications only)

Chiller is shut down because the voltage in any phase of line voltage has decreased below the under-voltage-shutdown threshold for 20 consecutive seconds,

or failed to achieve the minimum required starting line-voltage. Refer to explanation under “System Setpoints – SSS Motor Current/Volts”, page 11. The system will automatically restart when all phases of line voltage increase to the minimum required starting voltage.

MON XX:XX AM – HIGH LINE VOLTAGE

(Solid State Starter applications only)

Chiller is shut down because the voltage in any phase of line voltage has increased above the over-voltage threshold for 20 consecutive seconds. Refer to explanation under “System Setpoints – SSS Motor Current/Volts”, page 11. The system will automatically restart when all phases of line voltage decrease to the maximum allowable line voltage to start the chiller.

MON 09:30 AM – LOW OIL TEMPERATURE – AUTOSTART

The chiller is running and the oil temperature (as indicated by thermistor RT3) falls below 55°F, the chiller will shut down and display this message. The chiller will automatically restart when the oil temperature increases to >71°F AND is greater than the condenser saturated temperature by 20°F or 30°F depending upon how long the chiller was shut down. Refer to the message “MON XX:XX AM LOW OIL TEMP DIFF – AUTOSTART”.

MON XX:XX AM – LOW OIL TEMP DIFF – AUTOSTART

Indicates the chiller is shut down for one of the following reasons:

1. The chiller has been shut down for 30 minutes or less and the oil temperature minus the condenser saturation temperature is less than 30°F.

– or –

2. The chiller has been shut down for more than 30 minutes and the oil temperature minus the condenser saturation temperature is less than 40°F.

– or –

3. Following a power failure, the oil temperature minus the condenser saturation temperature is less than 40°F.

The chiller will restart automatically after the condition clears if the **COMPRESSOR** switch is in the **RUN** position.

NOTE: This check is made only when the chiller is shut down. It is not checked when the chiller is running or in “Start Sequence Initiated”.

DAY – TIME – OIL PRESSURE XDCR ERROR

Indicates the chiller has shut down because the difference between the High Side Oil Pressure Transducer Output and the Low Side Transducer Output was greater than 15.0 PSID during the “Transducer Auto-Zeroing Sequence” that occurs 10 seconds after a chiller start is initiated. Message is displayed immediately after the Auto-Zeroing sequence has completed. This indicates that one of the transducer outputs is incorrect, possibly due to an incorrect or defective transducer. To restart the chiller, press **COMPRESSOR** switch to **STOP/RESET** position and then to **START** position.

MON XX:XX AM – FAULTY DISCHARGE TEMP SENSOR

Whenever the discharge temperature falls below 30°F, or the discharge temperature sensor is disconnected from the Micro Board, the preceding message will appear. To restart the system when the discharge temperature rises or the sensor has been connected, press the **COMPRESSOR** switch to the **STOP/RESET** position and then to the **START** position.

MON XX:XX AM – PROX SENSOR SAFETY SHUTDOWN

The chiller is shut down because the “Proximity/Temperature Sensor” has detected that the distance between the compressor high speed thrust collar and the sensor probe has increased ≥ 10 mils or decreased ≥ 20 mils (25 mils with EPROM version C.02F(T).12 or later) from the “Reference Position”.

NOTE: With EPROM version C.02F (T).11, if the reference position is < 42 mils, the minimum allowed distance is 22 mils. With EPROM version C.02F(T).12 or later, if the reference position is < 44 mils, the minimum allowed distance is 19 mils.

IMPORTANT: *If the chiller has shut down displaying this message, it cannot be restarted until a qualified service technician performs a visual inspection of the high speed thrust bearing and performs a special reset procedure. This special reset procedure is detailed in YORK Service manual, Form 160.49-M3. Failure to perform the visual inspection prior to restarting the chiller could result in severe compressor damage!!!*

DAY – TIME – FAULTY PROXIMITY PROBE

The chiller has shut down because the “Proximity/Temperature Sensor” has detected that the distance between the compressor high speed thrust collar and the sensor probe has decreased to ≤ 17 mils.

IMPORTANT!!!: Although this message is generally indicative of a defective proximity probe, it is possible that the compressor has been damaged. If the high speed thrust bearing is not inspected by a qualified service technician prior to starting the chiller, further severe compressor damage could result. The chiller cannot be restarted until the “Special Reset Procedure” in YORK Service manual, Form 160.49-M3 is performed by a qualified service technician.

MON XX:XX AM – HIGH SPEED DRAIN TEMP

The chiller has shut down because the “Proximity/Temperature Sensor” has detected the temperature of the high speed drain line has reached 250.0°F or greater.

IMPORTANT: If the chiller has shut down displaying this message, it cannot be restarted until a qualified service technician performs visual inspection of the high speed thrust bearing and performs a special reset procedure. This special reset procedure is detailed in YORK Service manual, Form 160.49-M3. Failure to perform the visual inspection prior to restarting the chiller could result in severe compressor damage!!!

MON XX:XX AM – OPEN DRAIN TEMP THERMOCOUPLE

The chiller is shut down because the “Proximity/Temperature Sensor” thermocouple or high speed drain temperature wiring between the “Proximity/Temperature Sensor” module and the MicroComputer Control Center has been disconnected or has a poor electrical connection.

IMPORTANT: Open thermocouple shutdowns would typically indicate hardware or wiring defects and should not result in any damage to the compressor high speed thrust bearing. Therefore, a bearing inspection is not required. However, due to the critical nature of these circuits, anytime this shutdown occurs, a special reset procedure must be performed by a qualified service technician before the chiller can be restarted. This procedure is detailed in Service manual, Form 160.49-M3.

MON XX:XX AM – DC UNDERVOLTAGE

The “Proximity/Temperature Sensor” module becomes unstable in operation when the +24VDC supply decreases to +17VDC. Therefore, the Micro Board monitors the +24VDC supply and when it decreases to +19VDC, it shuts down the chiller and displays this message, preventing invalid “Proximity Sensor Safety” or “High Speed Drain Temp” safety shutdowns. The chiller will automatically restart when the voltage increases to greater than +19.7 VDC.

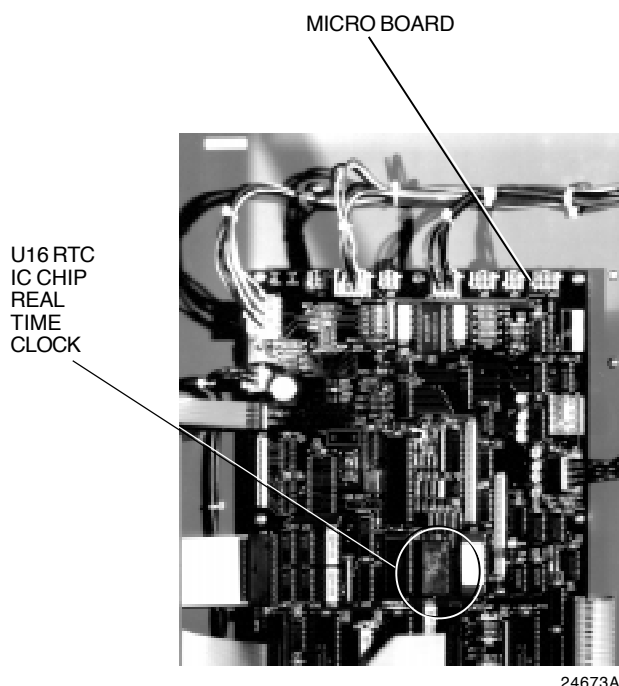

FIG. 14 – MICROCOMPUTER CONTROL CENTER LOCATION OF REAL TIME CLOCK U16 RTC IC CHIP

MON XX:XX AM – AUX SAFETY SHUTDOWN

The system is shut down because an external device, connected to digital input board TB1-31 (Auxiliary Safety Shutdown Input), has initiated a system shutdown. This input is a general purpose input that can be used to annunciate a user-defined safety shutdown. To restart chiller, press **COMPRESSOR** switch to **STOP-RESET** position and then to **START** position.

REPLACE RTC. U16 – REPROGRAM SETPOINTS

Indicates that the battery located inside the **REAL-TIME CLOCK** IC chip (U16 on the Micro Board) is defective. This battery provides back-up power to the RTC memory (RAM) in the event of a utility AC power failure. This assures the system setpoints will be maintained. If this message appears, the RTC IC chip (U16) on the Micro Board must be replaced. If there had been a power failure while this message is displayed, the setpoints will have been lost and must be reprogrammed. Order a replacement RTC IC chip (YORK part number 031-00955-000) from the YORK Parts Distribution Center. With AC power removed from system, locate RTC chip **U16** on the Micro Board and remove existing RTC chip from socket and discard. Observe anti-static precautions and install new RTC chip in socket. Assure proper IC orientation – orientation notch must be **UP**. (Refer to Fig. 14.)

SECTION 3

SYSTEM OPERATING PROCEDURES

WARNING

OIL HEATERS

If the oil heater is de-energized during a shut-down period, they must be energized for 12 hours prior to starting compressor, or remove all oil and recharge compressor with new oil. (See “Charging Unit With Oil”, page 43.)

NOTE: The oil heater is thermostatically controlled and remains energized as long as the fused disconnect switch to the starter or turbo-modulator is energized.

CHECKING THE OIL LEVEL IN THE OIL RESERVOIR

Proper operating oil level – the middle of the upper sight glass.

If the oil is excessively high after start-up, the excess oil may be drained from the oil filter drain valve while the compressor is running.

If oil level is low, oil should be added to the compressor. (See “Charging Unit With Oil”, page 43.)

START-UP PROCEDURE

PRE-STARTING

Prior to starting the chiller, observe the MicroComputer Control Center. Make sure the display reads

SYSTEM READY TO START

To pre-start the chiller, use the following procedure:

1. **Oil Heater** – The oil heater must be energized for 12 hours prior to starting the chiller. The unit will not start if the oil is less than 71°F. If not possible the compressor oil should be drained and new oil must be charged into the oil sump. (See “Charging Unit With Oil”, page 43.)
2. **Oil Pump** – To check, press and release the **MANUAL OIL PUMP** key under **Service** on the Control Center. The oil pump will run for 10 minutes and shut down. Press and release the **MANUAL OIL PUMP** key to stop the operation of the oil pump for less than 10 minutes of operation.
3. **Pre-Rotation Vanes** – To perform this test the starter interlock terminals 3 and 4 must be jumpered to allow vanes to open (remove the jumper after test). Make sure the Control Center is in the **SERVICE** mode, then press the prerotation vanes **OPEN** and **CLOSE** keys to observe the operation of the prerotation vanes. The Control Center supplies a signal to operate the prerotation vanes. The movement of the vanes will be dis-

played on the Control Center. The display readout is active whenever power is supplied to the Control Center. Return from the **SERVICE** mode to **LOCAL**, **PROGRAM**, or **REMOTE** mode to suit the method of operation selected for the chiller application. Refer to “Section 2”.

4. **% Current Limit** – Press the **% CURRENT LIMIT** setpoint key on the Control Center. The “Display” should read **CURRENT LIMIT = 100% FLA** on (Solid State Starter units only, the display is **CURRENT LIMIT = 100% FLA, MTR CUR = XXXX FLA**) if the Control Center was not programmed. If the setpoint is not 100% and was predetermined for the job application the Control Center should be programmed to that specification. To program, refer to “Section 2”.
5. All Control Center setpoints should be programmed before the chiller is started. (Refer to “Section 2”.) Prior to start, the clock must be programmed for the proper day and time. Any setpoints which are desired to be changed may be programmed. If not programmed the “default” value setpoints are as follows:
 - LCWT = 45°F
 - % Current Limit = 100% FLA
 - Pulldown Demand = None
 - Clock = Sun 12:00 A.M.
 - Daily Schedule = None
 - Holiday = None
 - Remote Reset Temp. Range = 20°F
 - Data Logger = No operation

START-UP

1. If the chilled water pump is manually operated, start the pump. The Control Center will not allow the chiller to start unless chilled liquid flow is established through the unit. (A field supplied chilled water flow switch is required.) If the chilled liquid pump is wired to the MicroComputer Control Center the pump will automatically start, therefore, this step is not necessary.
2. To start the chiller, press the **COMPRESSOR START** switch. This switch will automatically spring return to the **RUN** position. (If the unit was previously started, press the **STOP/RESET** side of the **COMPRESSOR** switch and then press the **START** side of the switch to start the chiller.) When the start switch is energized, the Control Center is placed in an operating mode and any malfunction will be noted by messages on the 40 character alphanumeric display. (See Fig. 3.)

*NOTE: Any malfunctions which occur during **STOP/RESET** are also displayed.*

When the chiller is shut down, the prerotation vanes will close automatically to prevent loading the compressor on start-up. When the prerotation vanes are fully closed the "Display" will read

SYSTEM READY TO START - VANES CLOSED

when in **SERVICE** mode.

When the chiller starts to operate, the following automatic sequences are initiated: (Refer to Fig. 15, "Chiller Starting & Shutdown Sequence Chart".)

1. The MicroComputer Control center alphanumeric display message will read **START SEQUENCE INITIATED** for the first 50 seconds of the starting sequence, (3 minutes if Micro Board JP6 removed).
2. The compressor vent line solenoid valve will open after the first 5.83 minutes of operation. The solenoid will close automatically after the compressor shuts down.
3. The 1R-1 contacts of the 1R start relay will remain open for the first 50 seconds of oil pump operation. These contacts will close, starting the compressor motor and the condenser water pump at the end of the 50 second period.
4. The oil pump will start to circulate oil for a 50 second pre-run to establish oil flow and adequate lubrication to all bearings, gears, and rotating surfaces within the compressor.

The high and low oil pressure transducers (OP) and the oil temperature sensor (RT3) will sense any malfunction in the lubrication system and activate one of the following display messages:

DAY 10:30 AM - LOW OIL PRESSURE

DAY 10:30 AM - HIGH OIL TEMPERATURE

DAY 10:30 AM - LOW OIL TEMP - AUTOSTART

DAY 11:30 AM - OIL PRESSURE TRANSDUCER

5. The anti-recycle timer software function will operate after the 50 seconds of pre-run time. At this time, the timer will be initiated and will run for 30 minutes after the compressor starts. If the chiller shuts down during this period of time, it cannot be started until the timer completes the 30 minute cycle.
6. The chilled liquid pump contacts will close starting the chilled liquid pump to allow liquid flow through the cooler when the **COMPRESSOR** start switch is energized.
7. After the first 50 seconds of operation, the compressor will start and the Control Center display message will read **SYSTEM RUN - CURRENT LIMIT IN EFFECT** while the motor is accelerating to full speed. When the motor reaches full speed and the current falls below 100% FLA the message will read **SYSTEM RUN - LEAVING TEMP. CONTROL**
8. For additional display messages and information pertaining to the operation of the MicroComputer Control Center, refer to "Section 2".
9. Low Oil Temp. Differential.

CHILLER OPERATION

After the compressor reaches its operating speed, the Prerotation Vanes will begin to open under the control of the Microprocessor Board which senses the leaving chilled liquid temperature. The unit capacity will vary to maintain the leaving **CHILLED LIQUID TEMPERATURE** setpoint. The Prerotation Vanes are modulated by an actuator under the control of the Microprocessor Board. The vane control routine employs proportional plus derivative (rate) control action. A drop in chilled liquid temperature will cause the actuator to close the Prerotation Vanes to decrease chiller capacity. When the chilled liquid temperature rises, the actuator will open the Prerotation Vanes to increase the capacity of the chiller.

SYSTEM STARTING & SHUTDOWN SEQUENCE OPERATOR INITIATED

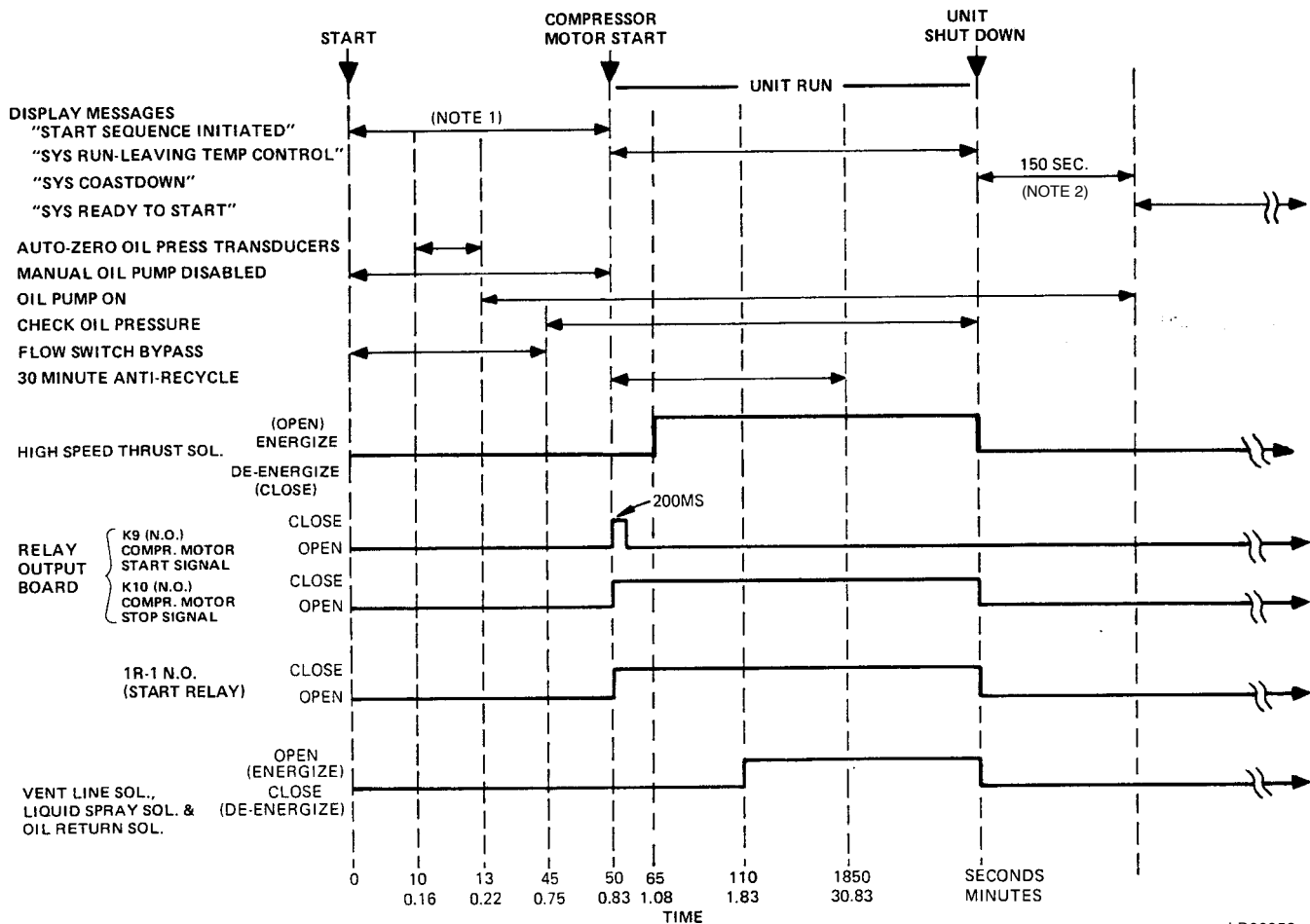

LD00952

NOTES: 1. REF. MICROBOARD PROGRAM JUMPER JP6
2. REF. MICROBOARD PROGRAM JUMPER JP4

FIG. 15 – CHILLER STARTING SEQUENCE & SHUTDOWN SEQUENCE

However, the current draw (amperes) by the compressor motor cannot exceed the setting of the **% CURRENT LIMIT** at any time during the unit operation, since the MicroComputer Control Center 40 to 100% three-phase peak current limit software function, plus the 3-phase 100% solid state overload current limiter (CM-2) on Electro-Mechanical Starter applications or the Solid State Starter current Limit function will override the temperature control function and prevent the Prerotation Vanes from opening beyond the **% CURRENT LIMIT** setting.

If the load continues to decrease, after the Prerotation Vanes are entirely closed, the chiller will be shut down by the Low Water Temperature control (LWT) function which is displayed on the Control Center as:

MON 10:30 AM – LOW WATER TEMPERATURE – AUTOSTART

This occurs when the leaving water temperature falls to 4°F below setpoint or 36°F, whichever is higher. The LWT is part of the Micro Board.

NOTE: If the temperature setpoint has been reprogrammed within the last 10 minutes, the LWT cutout is 36°F for 10 minutes.

Condenser Water Temperature Control

The YORK Millennium chiller is designed to use less power by taking advantage of lower than design temperatures that are naturally produced by cooling towers throughout the operating year. Exact control of condenser water such as a cooling tower bypass, is not necessary for most installations. The chiller requires only that the minimum condenser water temperature

be no lower than the value determined by referring to the formula below:

$$\text{Min. ECWT} = \text{LCHWT} - \text{C RANGE} + 5 + \left(\frac{15 \times \% \text{ LOAD}}{100} \right)$$

where:

- ECWT = entering condensing water temperature
- LCHWT = leaving chilled water temperature
- C RANGE = condensing water temperature range

At start-up, the entering condenser water temperature may be as much as 25°F colder than the standby return chilled water temperature. Cooling tower fan cycling will normally provide adequate control of the entering condenser water temperature on most installations.

CHECKING OPERATION

During operation, the following conditions should be periodically checked:

1. On starting, the prerotation vanes should remain closed until the compressor motor is up to speed on the run winding; then the vane motor should cause the vanes to modulate with load requirements.

2. Be sure the oil pump is operating while unit is running.
3. Check Oil Pressure display. A gradual decrease in bearing oil pressure of 5 to 10 psi (with constant suction and discharge pressures) may be an indication of a dirty filter. The filter should be replaced when pressure loss is 30% or more of the original pressure. The actual bearing oil pressure will vary with compressor suction and discharge pressures. When a new system is first operated under normal full load conditions, the bearing oil pressure should be recorded as a reference point with which to compare subsequent readings.

OPERATING LOG SHEET

A permanent daily record of system operating conditions (temperatures and pressures) recorded at regular intervals throughout each 24 hour operating period should be kept.

An optional status printer is available for this purpose or Fig. 16 shows a log sheet used by YORK Personnel for recording test data on chiller systems. It is available from the factory in pads of 50 sheets each under Form 160.44-F6 and may be obtained through the nearest

YORK
Maintenance & Energy Services

LIQUID CHILLER LOG SHEET

Chiller Location _____
System No. _____

* Date	
* Time	
Hour Meter Reading	
O.A. Temperature D.B./W.B.	
Compressor	* Oil Level
	* Oil Pressure
	* Oil Temperature
	* Suction Temperature
	* Discharge Temperature
PRV % Open	
Meter	Volts
	* Amps *% FLA
Refrig.	* Suction Pressure
	* Inlet Temperature
	* Inlet Pressure
	* Outlet Temperature
Cooler	* Outlet Pressure * ISAT TEMP
	* Flow Rate—GPM
	* Discharge Pressure
Refrig.	* Corresponding Temp * (SAT TEMP)
	* High Pressure Liquid Temperature
	* System Air—Degrees
	* Inlet Temperature
Water	* Inlet Pressure
	* Outlet Temperature
	* Outlet Pressure
	* Flow Rate—GPM

Remarks: _____

YORK
Maintenance & Energy Services

LIQUID CHILLER LOG SHEETS

... an Energy-Saving approach to your Service needs ...



LD00467

FORM 160.44-F6

*NOTE: These items can be printed by an electronic printer connected to TB8 of the Micro Board and pressing the **PRINT** key on the Micro Board or automatically using the Data Logger feature.

FIG. 16 – LIQUID CHILLER LOG SHEETS

YORK office. Automatic data logging is possible by connecting the optional printer and programming the DATA LOGGER function; refer to Form 160.49-N7.

An accurate record of readings serves as a valuable reference for operating the system. Readings taken when a system is newly installed will establish normal conditions with which to compare later readings.

For example, an increase in condenser approach temperature (condenser temperature minus leaving condenser water temperature) may be an indication of dirty condenser tubes.

OPERATING INSPECTIONS – See Section 2

By following a regular inspection using the display readings of the MicroComputer Control Center, and maintenance procedure, the operator will avoid serious operating difficulty. The following list of inspections and procedures should be used as a guide.

Daily

1. Check MicroComputer Control Center displays.
2. If the compressor is in operation, check the bearing oil pressure by pressing **OIL PRESSURE** key to read the display on the Control Center. Also check the oil level in the oil reservoir. Operating oil level should be between the upper and lower sight glasses. Drain or add oil if necessary.
3. Check entering and leaving condenser water pressure and temperatures for comparison with job design conditions. Condenser water temperatures can be checked by pressing **CONDENSER LIQUID TEMPERATURES** display key.
4. Check the entering and leaving chilled liquid temperatures and evaporator pressure for comparison with job design conditions. This can be accomplished by pressing the **CHILLED LIQUID TEMPS** key and the **REFRIGERANT PRESSURES** key.
5. Check the condenser saturation temperature (based upon condenser pressure sensed by the condenser transducer). Press the **DISPLAY DATA** key. This key may be depressed repeatedly after depressing the **DISPLAY HOLD** key to display three different parameters.
6. Check the compressor discharge temperature. Press **DATA DISPLAY** key. During normal operation discharge temperature should not exceed 220°F.

7. Check the compressor motor voltage and current (amps) at E-M starter (or Variable Speed Drive), or on the Control Center display for Solid State Starter units.
8. Check for any signs of dirty or fouled condenser tubes. (The temperature difference between water leaving condenser and liquid refrigerant leaving the condenser should not exceed the difference recorded for a new unit by more than 4°F.)
9. Press the **STATUS** key whenever the display indicates so. This allows any warning messages to be displayed.

Weekly

1. Check the refrigerant charge. (See “Checking The Refrigerant Charge”, page 52.)

Quarterly

1. Perform chemical analysis of oil.

Semi-Annually (or more often as required)

1. Change and inspect compressor oil filter element.
2. Oil return system.
 - a. Change dehydrator.
 - b. Check nozzle of eductor for foreign particles.
3. Check controls and safety cutouts.

Annually (more often if necessary)

1. Drain and replace the oil in the compressor oil sump. (See “Charging The Unit With Oil”, page 43.)
2. Cooler and Condenser.
 - a. Inspect and clean water strainers.
 - b. Inspect and clean tubes as required.
 - c. Inspect end sheets.
3. Compressor Drive Motor (See motor manufacturers maintenance and service instruction supplied with unit)
 - a. Clean air passages and windings per manufacturers instructions.
 - b. Meg motor windings – See Fig. 23 for details.
 - c. Re-lubricate ball bearings.

4. Inspect and service electrical components as necessary.
5. Perform chemical analysis of system.

NEED FOR MAINTENANCE OR SERVICE

If the system is malfunctioning in any manner or the unit is stopped by one of the safety controls, consult the "Operation Analysis Chart", pages 47 through 48 of this instruction. After consulting this chart, if you are unable to make the proper repairs or adjustments to start the compressor or the particular trouble continues to hinder the performance of the unit, please call the nearest YORK District Office. Failure to report constant troubles could damage the unit and increase the cost of repairs considerably.

NORMAL AND SAFETY SYSTEM SHUTDOWNS

Normal and safety system shutdowns have been built into the chiller to protect it from damage during certain operating conditions. Therefore, it should be understood that at certain pressures and temperatures the system will be stopped automatically by controls that respond to high temperatures, low temperatures, and low and high pressures, etc. Table 1 is an explanation of each specific shutdown. If the chiller shuts down on a "Safety" shutdown, the display will read

SYSTEM SHUTDOWN – PRESS STATUS

Upon pressing the **STATUS** key, the day-of-week, time-of-day and cause of shutdown is displayed. Safety shutdowns require the operator to manually reset the Control Center prior to restarting the chiller. When the display reads **START SEQUENCE INITIATED**, the cause of the safety shutdown is automatically cleared from the memory.

SAFETY SHUTDOWNS

- Power Failure (If auto restart programming jumper is not installed on the Micro Board)
- Low Evaporator Pressure
- Low Oil Pressure
- High Condenser Pressure
- Evaporator Transducer or Probe Error
- High Discharge Temp
- High Oil Temp
- Oil Pressure Transducer
- Starter Malfunction Detected
- Faulty Discharge Temp Sensor
- Aux. Safety Shutdown

- Motor Phase Current Unbalance (Solid State Starter Unit only)
- Proximity sensor
- Faulty Prox. Probe
- Open Drain Thermocouple

If the chiller shuts down on a "Cycling" shutdown the display will read **SYSTEM SHUTDOWN – PRESS STATUS**. Upon pressing the **STATUS** key, the day-of-week, time-of-day and cause of shutdown are displayed. These shutdowns do not require the operator to manually reset the Control Center prior to re-starting the chiller. The chiller will automatically restart when the cycling condition is removed.

CYCLING SHUTDOWNS

- Power Failure (If auto re-start programming jumper is installed on the Micro Board)
- Low Water Temp
- Flow Switch
- System Cycling
- Multi-Unit Cycling
- Internal Clock
- Anti-Recycle
- Motor Controller (Manual reset of the CM-2 module on E-M starter units; the logic board of the Solid State Starter may be required)
- Power Fault
- Program Initiated Reset
- Low Oil Temp
- AC Undervoltage
- DC Undervoltage
- Low Line Voltage (Solid State Starter units only)
- High Line Voltage (Solid State Starter units only)
- Low Oil Temp. Differential

STOPPING THE SYSTEM (See Fig. 3, page 6)

The MicroComputer Control Center can be programmed to start and stop automatically (maximum, once each day) whenever desired. Refer to "Section 2". To stop the chiller, proceed as follows:

1. Push the **COMPRESSOR STOP/RESET** switch. The Control Center display will show **SYSTEM COASTDOWN** for 150 seconds. If unit is configured for a STEAM TURBINE application (program jumper JP4 removed), this period is extended to allow for a longer coastdown time. EPROM version C.02F(T).11 provides a 6 minute coastdown

period. EPROM version C.02F(T).12 or later provides a 10 minute coastdown period. The compressor, condenser water, and cooling tower fans will stop automatically. The oil pump will continue to run for coastdown period. The oil pump will then stop automatically. Once stopped, the

SYSTEM COASTDOWN display will be replaced by **SYSTEM READY TO START**.

2. Stop the chilled water pump (if not wired into the MicroComputer Control Center, in which case it will shut off automatically simultaneously with the oil pump.) (The actual water pump contact operation is dependent upon the position of Micro Board jumper J54.)
3. Open the switch to the cooling tower fan motors, if used.
4. The compressor sump oil heater (thermostatically controlled) is energized when the unit is stopped.

PROLONGED SHUTDOWN

If the chiller is to be shut down for an extended period of time (for example, over the winter season), the following paragraphs outline the procedure to be followed.

1. Test all system joints for refrigerant leaks with a leak detector. If any leaks are found, they should be repaired before allowing the system to stand for a long period of time.

During long idle periods, the tightness of the system should be checked periodically.

2. If freezing temperatures are encountered while the system is idle, carefully drain the cooling water from

the cooling tower, condenser, condenser pump, and the chilled water system-chilled water pump and coils.

Open the drains on the cooler and condenser liquid heads to assure complete drainage. (If a Variable Speed Drive, drain its water cooling system. If Solid State Starter, drain water from starter cooling loop.)

3. Move jumper J-57 on the Micro Board from CLOCK ON position (CLKON) to CLOCK OFF position (CLKOFF) while 115VAC control power is applied. This conserves the battery.
4. Open the main disconnect switches to the compressor motor, condenser water pump and the chilled water pump. Open the 115 volt circuit to the Control Center.

START-UP AFTER PROLONGED SHUTDOWN

1. When putting the system into operation after prolonged shutdown (during the winter), remove all oil from the compressor. Install a new filter element and charge compressor with fresh oil. Move jumper J-57 on the Micro Board from CLOCK OFF position (CLKOFF) to CLOCK ON position (CLKON) and reset the clock. Energize the 115 volt circuit to the Control Center to energize the compressor sump oil heater for at least 12 hours.
2. Operate the Oil Pump (press and release the **MANUAL OIL PUMP** key) until steady oil pressure is established. Then press and release the **OIL PUMP** key to stop operation of the oil pump. If the water systems were drained, fill the condenser water circuit and chilled liquid circuit.

SECTION 4 SYSTEM COMPONENTS DESCRIPTION

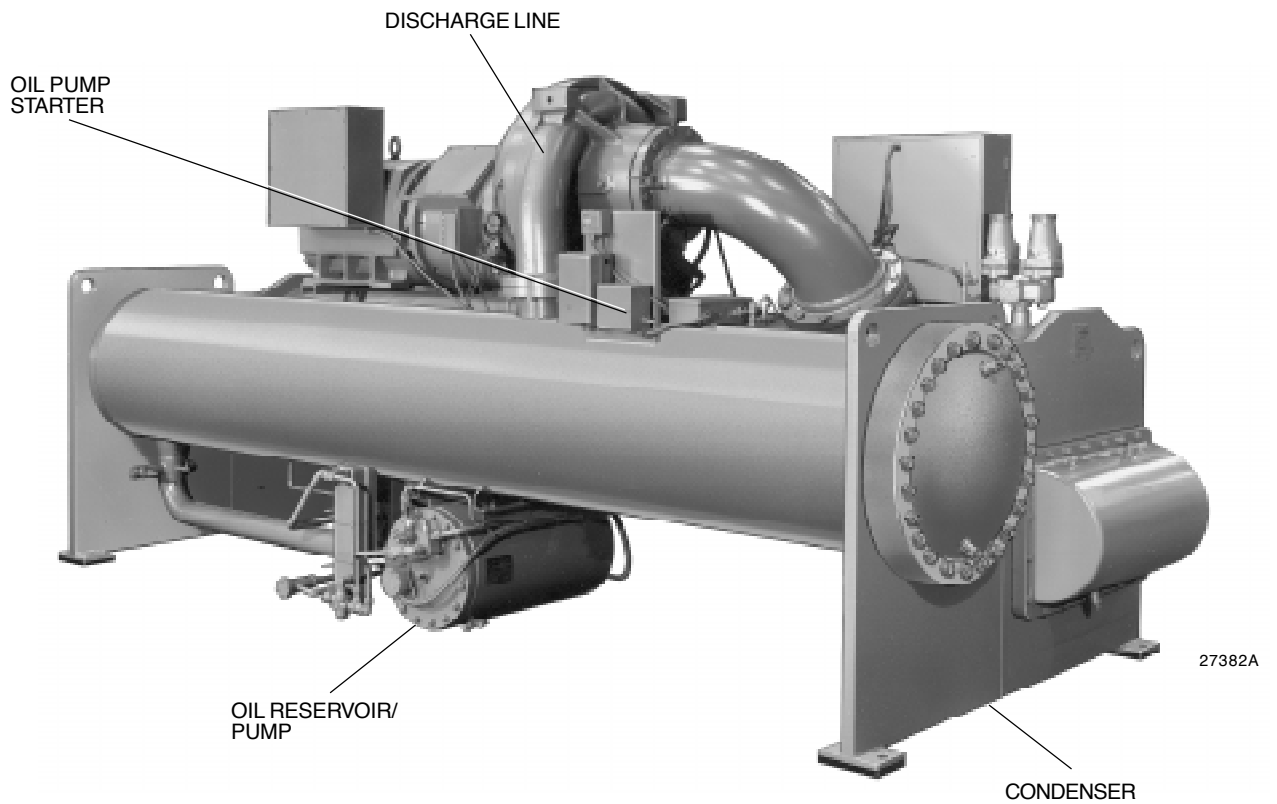
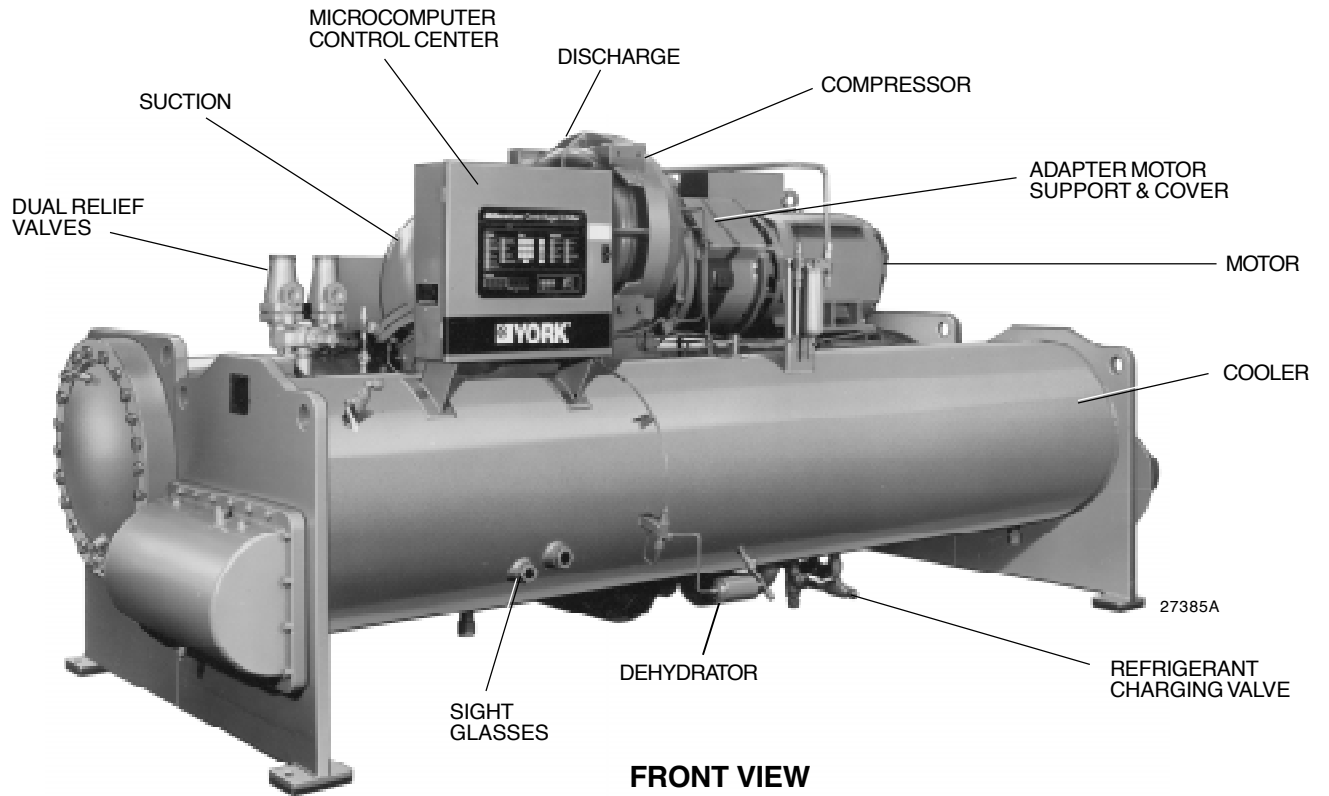

FIG. 17 – SYSTEM COMPONENTS

GENERAL

The YORK Model YK Millennium Centrifugal Liquid Chiller is completely factory-packaged including cooler, condenser, compressor, motor, lubrication system, MicroComputer Control Center, and all interconnecting unit piping and wiring.

The initial charge of refrigerant and oil is supplied for each unit. Oil is shipped in containers with the chiller. Refrigerant is shipped to the jobsite in cylinders at the time of installation.

The services of a YORK factory-trained, field service representative are included to supervise the final leak testing, charging and the initial start-up and concurrent operator instructions.

COMPRESSOR

The compressor is a single-stage centrifugal type powered by an open-drive electric motor.

The rotor assembly consists of a heat-treated alloy steel drive shaft and impeller shaft with a cast aluminum, fully shrouded impeller. The impeller is designed for balanced thrust and is dynamically balanced and over-speed tested.

The inserted type journal and thrust bearings are fabricated of aluminum alloy. Single helical gears with crowned teeth are designed so that more than one tooth is in contact at all times. Gears are integrally assembled in the compressor rotor support and are film lubricated. Each gear is individually mounted in its own journal and thrust bearings.

The open-drive compressor shaft seal consists of a spring-loaded, precision carbon ring, high temperature elastomer "O" ring static seal, and stress-relieved, precision lapped collars. The seal is oil-flooded at all times and is pressure-lubricated during operation.

CAPACITY CONTROL

Prerotation vanes (PRV) modulate chiller capacity from 100% to as low as 15% of design for normal air conditioning applications. Operation is by an external, electric PRV actuator which automatically controls the vane position to maintain a constant leaving chilled liquid temperature.

COMPRESSOR LUBRICATION SYSTEM (See Fig. 18)

The chiller lubrication system consists of the oil pump, oil filter, oil cooler and all interconnecting oil piping and passages. There are main points within the motor-com-

pressor which must be supplied with forced lubrication as follows:

1. COMPRESSOR DRIVE SHAFT (Low Speed)
 - a. Shaft seal.
 - b. Front and rear journal bearings – one on each side of driving gear.
 - c. Low speed thrust bearing (forward and reverse).
2. COMPRESSOR DRIVEN SHAFT (High Speed)
 - a. Forward and reverse high speed thrust bearing.
 - b. Two journal bearings.
3. SPEED INCREASING GEARS
 - a. Meshing surfaces of drive and pinion gear teeth.

To provide the required amount of oil under the necessary pressure to properly lubricate these parts, a motor driven submersible oil pump is located in a remote oil sump.

Upon pressing of the **COMPRESSOR START** switch on the Control Center, the oil pump is immediately energized. After a 50 second delay to allow the system oil pressure to stabilize, the compressor motor will start. The oil pump will continue to run during the entire operation of the compressor, and for 150 seconds during compressor coastdown.

The submerged oil pump takes suction from the surrounding oil and discharges it to the oil cooler where heat is rejected. The oil flows from the oil cooler to the oil filter. The oil leaves the filter and flows to the emergency oil reservoir where it is distributed to the compressor bearings. The oil lubricates the compressor rotating components and is returned to the oil sump.

Since the emergency oil reservoir is at the highest point in the lubrication system, it provides an oil supply to the various bearings and gears in the event of a system shutdown due to power failure. The reservoir, located on the top of the compressor, allows the oil to be distributed through the passages by gravity flow, thus providing necessary lubrication during the compressor coastdown.

OIL PUMP

For normal operation, the oil pump should operate at all times during chiller operation. Manual pump operation may be used to establish stable oil pressure before starting. When depressed and released, the **MANUAL OIL PUMP** key will operate the oil pump for 10 minutes and then automatically shut off. To stop the

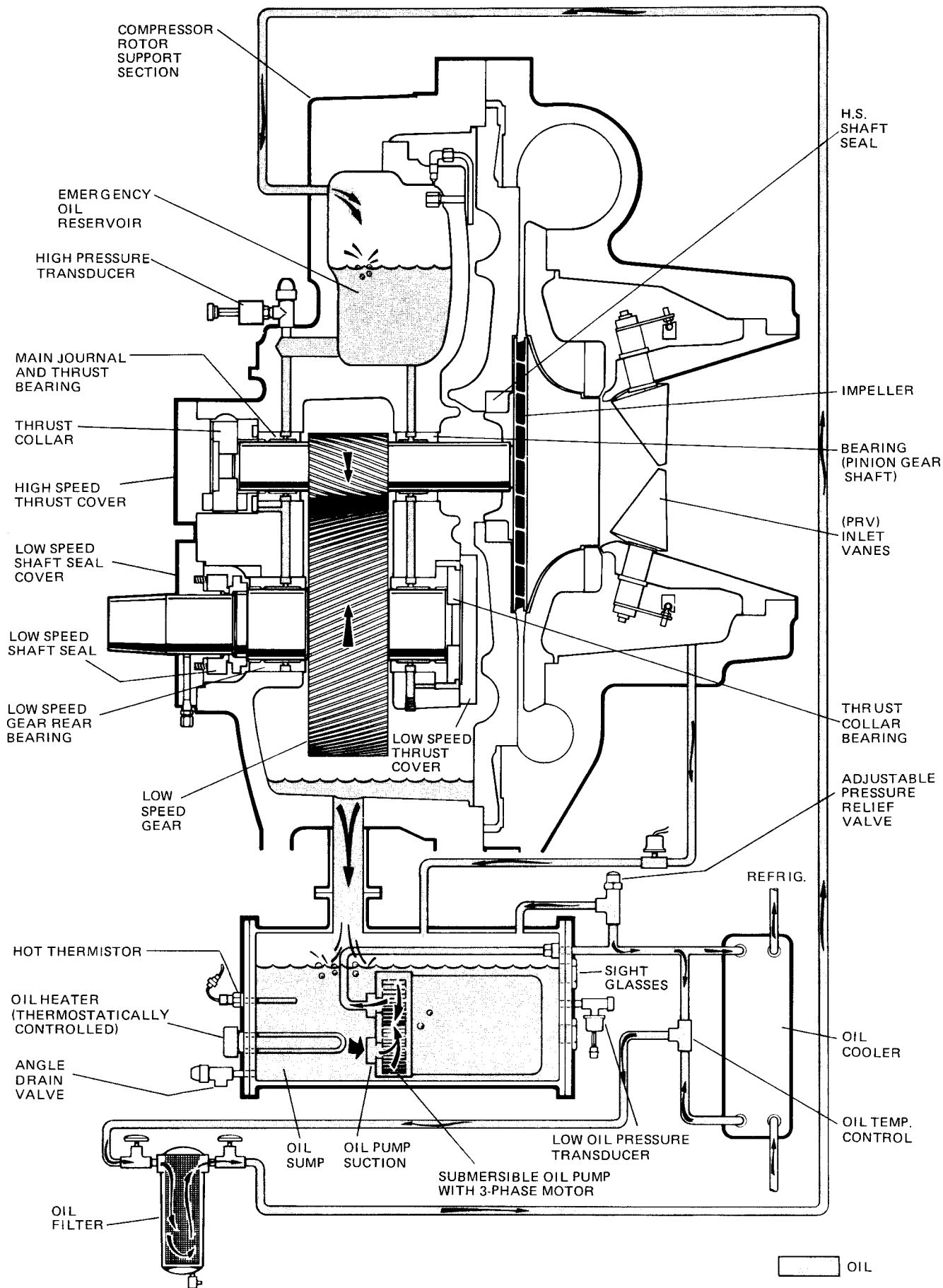

FIG. 18 - SCHEMATIC DRAWING - (YK) COMPRESSOR LUBRICATION SYSTEM

LD00951

oil pump sooner, depress the **MANUAL OIL PUMP** key again.

On shutdown of the system for any reason, the oil pump operates and continues to run for 150 seconds. The system cannot restart during that time interval.

OIL HEATER

During long idle periods, the oil in the compressor oil reservoir tends to absorb as much refrigerant as it can hold, depending upon the temperature of the oil and the pressure in the reservoir. As the oil temperature is lowered, the amount of refrigerant absorbed will be increased. If the quantity of refrigerant in the oil becomes excessive, violent oil foaming will result as the pressure within the system is lowered on starting. This foaming is caused by refrigerant boiling out of the oil as the pressure is lowered. If this foam reaches the oil pump suction, the bearing oil pressure will fluctuate with possible temporary loss of lubrication, causing the oil pressure safety cutout to actuate and stop the system. See "Control Center, Section 2".

To maintain the lowest possible concentration of refrigerant in the oil, the compressor oil reservoir is equipped with a 115 volt electric reservoir oil heater. The oil heater is thermostatically controlled at all times during compressor shutdown to maintain the sump oil at 145°F to 155°F. If the oil temperature falls below 55°F, the display will read

SYSTEM SHUTDOWN – PRESS STATUS .

Pressing the **STATUS** key causes the message to read

DAY 10:00 AM – LOW OIL TEMP – AUTO START .

The system will be allowed to automatically restart when oil temperature rises to 30°F above condenser temperature.

MOTOR DRIVELINE

The compressor motor is an open-drip-proof, squirrel cage, induction type constructed to YORK design specifications. 60 hertz motors operate at 3570 rpm. 50 hertz motors operate at 2975 rpm.

(For 60 hertz motors 1750 HP and smaller; and 50 hertz motors 1400 HP and smaller) . . . the open motor is provided with a D-flange, factory mounted to a cast iron adapter mounted on the compressor.

(For 2000 HP 60 hertz motors; and 50 hertz motors above 1400 HP) . . . a separate structural steel base is furnished to provide rigid mounting of the compressor and motor, independent of the evaporator shell, to ensure controlled alignment of the assembly. Motor is mounted with final alignment at start-up.

Motor drive shaft is directly connected to the compressor shaft with a flexible disc coupling. Coupling has all metal construction with no wearing parts to assure long life, and no lubrication requirements to provide low maintenance.

For units utilizing remote electro-mechanical starters, a terminal box is provided for field connected conduit. Motor terminals are brought through the motor casing into the terminal box. Jumpers are furnished for three-lead type of starting. Motor terminal lugs are not furnished. Overload/overcurrent transformers are furnished with all units. For units furnished with factory packaged Solid State Starters, (optional) see right.

HEAT EXCHANGERS

Evaporator and condenser shells are fabricated from rolled carbon steel plates with fusion welded seams.

Heat exchanger tubes are internally enhanced type.

The evaporator is a shell and tube, flooded type heat exchanger. A distributor trough provides uniform distribution of refrigerant over the entire shell length. Aluminum mesh eliminators are located above the tube bundle to prevent liquid refrigerant carryover into the compressor. Two 1-1/2" liquid level sight glasses are located on the side of the shell to aid in determining proper refrigerant charge. The evaporator shell contains a dual refrigerant relief valve.

The condenser is a shell and tube type, with a discharge gas baffle to prevent direct high velocity impingement on the tubes. A separate subcooler is located in the condenser.

The removable compact water boxes are fabricated of steel. The design working pressure is 150 psig and the boxes are tested at 225 psig. Integral steel water baffles provide the required pass arrangements. Stub-out water nozzle connections with Victaulic grooves are welded to the water boxes. These nozzle connections are suitable for Victaulic couplings, welding or flanges, and are capped for shipment. Plugged 3/4" drain and vent connections are provided in each water box.

REFRIGERANT FLOW CONTROL

Refrigerant flow to the evaporator is controlled by a single fixed-orifice (or variable orifice).

Chillers can be provided with a REFRIGERANT LEVEL CONTROL (EPROM version C.02.F(T).13 or later supports this feature). A level sensor senses the refrigerant level in the condenser and outputs an analog volt-

age to the Micro Board that represents this level (0% = empty; 100% = full). Under program control, the Micro Board modulates a variable orifice to control the condenser refrigerant level to a programmed setpoint. Other setpoints affect the control sensitivity and response. These setpoints must be entered at chiller commissioning by a qualified service technician. Only a qualified service technician may modify these settings. Manual operation of the refrigerant level control can be selected. This allows the prerotation vanes keypad keys to manually control the variable orifice. This manual control can also be used to position the variable orifice in a fixed position. Instructions for selecting manual level control and entering the level control setpoints are contained in the "Special Setpoints and Programming Procedures" section of Service manual, Form 160.49-M3.

While the chiller is shut down, the orifice will be in the fully open position causing the sensed level to be approximately 0%. When the chiller is started, after the vane motor end switch (VMS) opens when entering "SYSTEM RUN", if actual level is less than the level setpoint, a linearly increasing ramp is applied to the level setpoint. This ramp causes the setpoint to go from the initial refrigerant level (approximately 0%) to the programmed setpoint over a period of 15 minutes. While this ramp is in effect,

PULLDN LEVEL = XXX%; SETP = XXX%; ACTUAL = XXX% is one of the scrolled messages under the **DISPLAY DATA** key. "PULLDN LEVEL" is the ramping setpoint that will ramp up to the programmed setpoint "SETP". "SETP" is the level setpoint programmed by the service technician. "ACTUAL" is the present refrigerant level in the condenser. After the 15 minute pulldown period has elapsed, this message is replaced by

ACTUAL LEVEL = XXX%; LEVEL SETP = XXX%.

If the actual level is greater than the setpoint when the VMS opens, there is no pulldown period, it immediately begins to control to the programmed setpoint.

While the chiller is running, the refrigerant level is normally controlled to the level setpoint. However, anytime the vanes fully close (VMS closes), normal level control is terminated, any refrigerant level setpoint pulldown in effect is cancelled and the outputs to the level control will be opposite that which is supplied to the vane motor (i.e., when a close pulse is applied to the vane motor, an open pulse is applied to the level

control, etc.). When the VMS opens, if the refrigerant level is less than the level setpoint, a refrigerant level setpoint pulldown is initiated as described above. Otherwise, the level is controlled to the programmed setpoint.

If the refrigerant level sensor output ever goes to greater than 4.4VDC, indicating a level greater than 100%,

WARNING-REFRIGERANT LEVEL OUT OF RANGE is displayed and the level control actuator is driven open until the level has decreased to a level within range. When within range, the warning message is automatically cleared and normal control is resumed.

MICROCOMPUTER CONTROL CENTER (See Section 2)

The MicroComputer Control Center is factory mounted, wired and tested. The electronic panel automatically controls the operation of the unit in meeting system cooling requirements while minimizing energy usage. For detailed information on the Control Center, refer to "Section 2" of this manual.

SOLID STATE STARTER (Optional)

The Solid State Starter is a reduced voltage starter that controls and maintains a constant current flow to the motor during start-up. It is mounted on the chiller. Power and control wiring between the starter and chiller are factory installed. Available for 380-600 volts, the starter enclosure is NEMA-1 with a hinged access door with lock and key. Electrical lugs for incoming power wiring are provided.

VARIABLE SPEED DRIVE (Optional)

A 460V – 3-Ph – 60/50Hz Variable Speed Drive can be factory packaged with the chiller. It is designed to vary the compressor motor speed and prerotation vane position by controlling the frequency and voltage of the electrical power to the motor. Operational information is contained in Form 160.00-O1. The control logic automatically adjusts motor speed and compressor prerotation vane position for maximum part load efficiency by analyzing information fed to it by sensors located throughout the chiller.

SECTION 5 OPERATIONAL MAINTENANCE

OIL RETURN SYSTEM

The oil return system continuously maintains the proper oil level in the compressor oil sump. (See Figs. 18 & 19.)

High pressure condenser gas flows continuously through the eductor inducing the low pressure, oil rich liquid to flow from the evaporator, through the dehydrator to the compressor sump.

CHANGING THE DEHYDRATOR

To change the dehydrator, use the following procedure:

1. Shut the stop valves on the condenser gas line, oil return line to rotor support and inlet end of the dehydrator.
2. Remove the dehydrator. Refer to Fig. 19.
3. Assemble the new filter-drier.
4. Open condenser stop valve and check dehydrator connections for refrigerant leaks.
5. Open all the dehydrator stop valves to allow the liquid refrigerant to flow through the dehydrator and condenser-gas through the eductor.

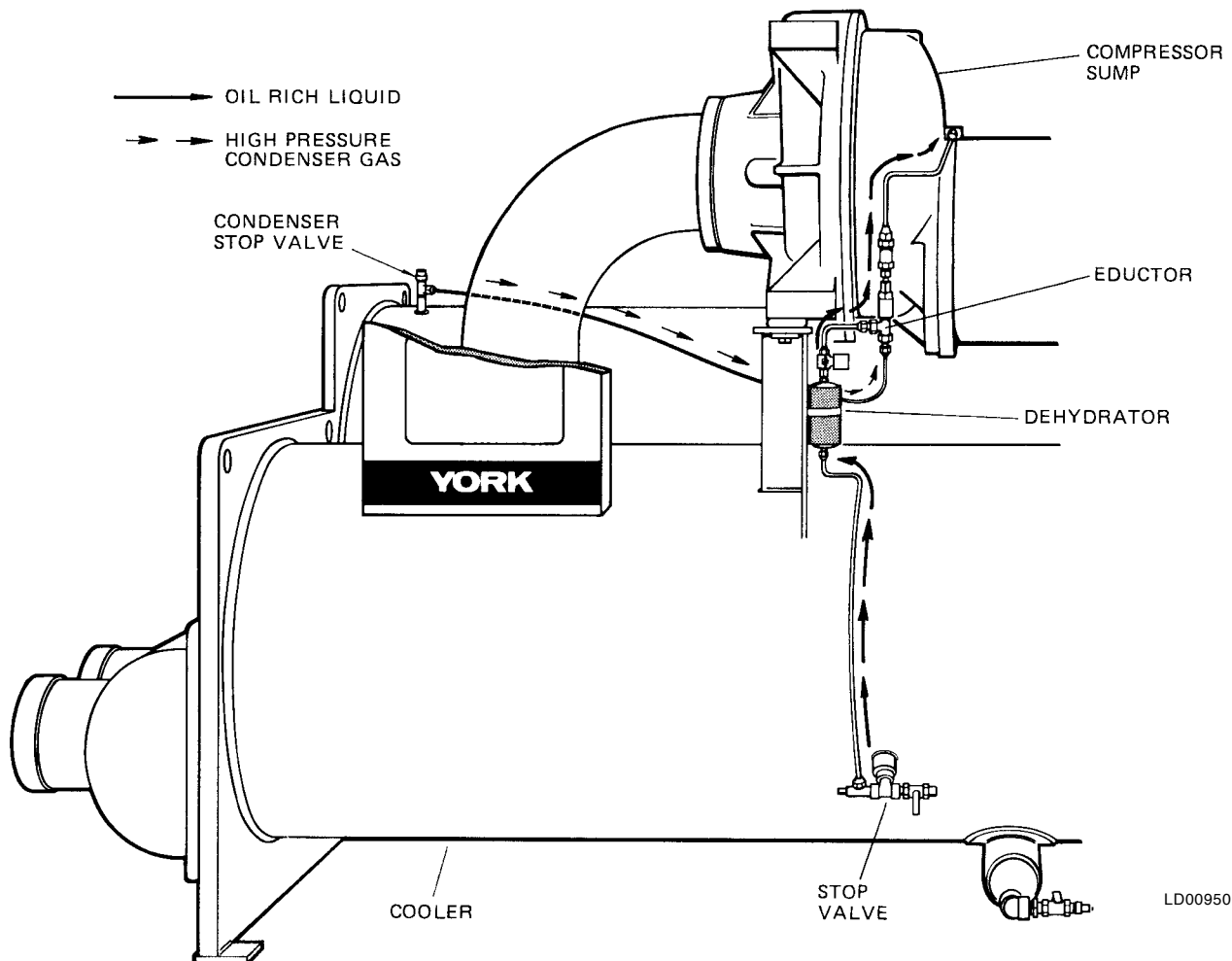

FIG. 19 – OIL RETURN SYSTEM

THE OIL CHARGE

The nominal oil charge for the compressor is 20 gal., type “F” for R-22 application or type “K” for R-134a application.

New YORK Refrigeration oil must be used in the centrifugal compressor. Since oil absorbs moisture when exposed to the atmosphere, it should be kept tightly capped until used.

OIL CHARGING PROCEDURE

The oil should be charged into the oil reservoir using the YORK Oil Charging Pump – YORK Part No. 070-10654. To charge oil into the oil reservoir, proceed as follows:

1. The unit must be shut down.
2. Immerse the suction connection of the oil charging pump in a clean container of new oil and connect the pump discharge connection to the oil charging valve (A) located on the remote oil reservoir cover

plate. (See Fig. 20.) Do not tighten the connection at the charging valve until after the air is forced out by pumping a few strokes of the oil pump. This fills the lines with oil and prevents air from being pumped into the system.

3. Open the oil charging valve and pump oil into the system until oil level in the compressor oil reservoir is about midway in the upper sight glass. Then, close the charging valve and disconnect the hand oil pump.
4. As soon as oil charging is complete, close the power supply to the starter to energize the oil heater. (See “Section 3, System Operating Procedures”.) This will keep the concentration of refrigerant in the oil to a minimum.

When the oil reservoir is initially charged with oil, the oil pump should be started manually to fill the lines, passages, oil cooler and oil filter. This will lower the oil level in the reservoir. It will then be necessary to add oil to bring the level back to the center of the upper sight glass.



OIL CHARGING VALVE

25721A

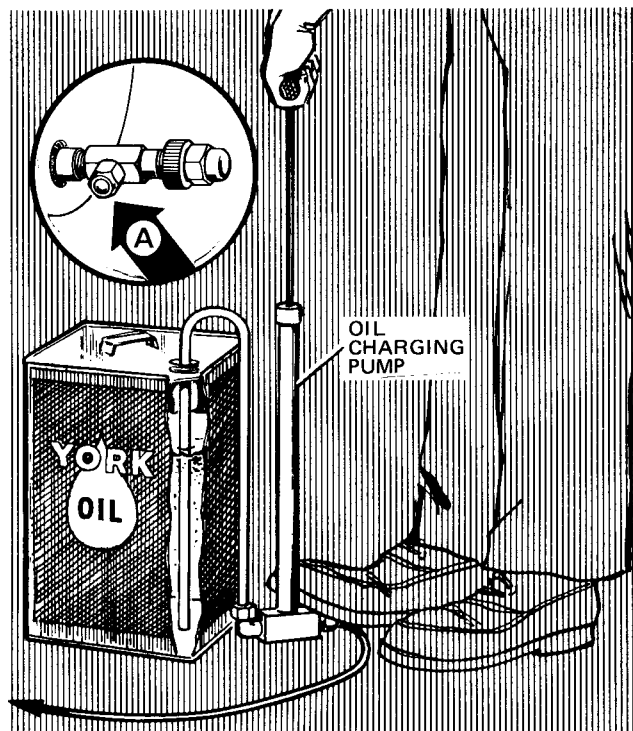

OIL CHARGING PUMP

LD00472

FIG. 20 – CHARGING OIL RESERVOIR WITH OIL

TABLE 1 – CAUSES OF NORMAL AND SAFETY SYSTEM SHUTDOWNS IN ACCORDANCE WITH THE MICROCOMPUTER CONTROL, CENTER DISPLAY

SHUTDOWN CAUSE CONTROL CENTER DISPLAY				GOVERNING CONTROL FUNCTION			PROGRAMMED SETPOINTS BY OPERATOR	START-UP OF SYSTEM AFTER SHUTDOWN	PROBABLE CAUSE AND SERVICE REQUIRED
DAY OF WEEK	TIME OF DAY	CAUSE OF SHUTDOWN	METHOD OF RESTART	DESCRIPTION	OPERATING POINT				
					ON RISE	ON FALL			
MON.	10:00 AM	Low Water Temp.	Autostart	Low Water (LWT)	Chilled water setpoint	4°F below chiller water setpoint	4°F below chilled water setpoint (If set to 40°F would be 36°F) (36°F minimum)	Automatic Restart when water reaches setpoint; if system is running and set- point is increased 4°F, system will continue to run, as LWT cutout shifts to a fixed 36°F for 10 minutes.	System load is less than minimum capacity
MON.	10:00 AM	Flow Switch	Autostart	Flow Switch				Automatic Restart when water flow is Restored to close flow switch.	Lack of water flow. Check operation of chilled water pump
MON.	10:00 AM	System Cycling	Autostart	A remote com- mand (computer relay contact or manual switch)				Automatic Restart upon remote command.	Contact-connected to the Remote/Local cycling input of the Digital input board
MON.	10:00 AM	Multi-Unit	Autostart	(Optional) Lead- Lag Sequence Control				Automatic Restart upon remote command.	Contact-connected to the Multi-Unit cycling input of the Digital input board
MON.	10:00 AM	Internal Clock	Autostart	Internal Clock			Daily Schedule Programmed to Shutdown Unit	Will automatically restart when pro- grammed schedule permits	Pressing Compressor Start Switch over- rides the program
MON.	10:00 AM	AC under- voltage	Autostart	<15% FLA for 25 continuous seconds					Cycling shutdown oc- curs when motor cur- rent is >15% FLA for 25 seconds during chiller operation
MON.	10:00 AM	Power Fault	Autostart	CM-2 Current Module or Solid State Starter				Will start automatic- ally following coastdown	Motor Controller con- tacts opening and closing in less than 3 seconds due to a power fault condition
		Remote Stop		Energy manage- ment System				Start up by start signal from remote start switch	Remote Stop Contact Closure
MON.		Anti-Recycle, 20 Min. Left		Anti-Recycle timer			Will not start until 30 Min. timer is timed	Will restart when time left = 00 Min.	Min. Time between successive compres- sor starts is 30 min.

**SECTION 6
TROUBLESHOOTING**

MON.	10:00 AM	Low Evap. Pressure		Low Evap. Pressure Transducer (LEP)	54.3 PSIG (R-22) 25 PSIG (R-134a)	54.4 PSIG (R-22) 25.1 PSIG (R-134a)		To restart, press compressor switch from STOP/RESET to START position	See OPERATION ANALYSIS Table 2 Symptom 2
MON.	10:00 AM	Low Evap. Pressure Brine		LEP external control (Brine units only)	Set to Job Spec.	Set to Job Spec.		To restart, press compressor switch from STOP/RESET to START position	See OPERATION ANALYSIS Table 2 Symptom 2.
MON.	10:00 AM	Low Oil Pressure		Low Oil Pressure Transducer (OP)	25 PSID	15 PSID		Will restart when pressure increases to 25 PSID. To restart, press compressor switch from STOP/RESTART to START position.	Refer to OPERATION ANALYSIS Table 2 Symptoms 4, 5, 6, 7, 9, 10, 11
MON.	10:00 AM	High Pressure		High Pressure Safety Control (HP)	265 PSIG (R-22) 180 PSIG (R-134a)	205 PSIG (R-22) 120 PSIG (R-134a)		Will restart when Pressure falls to 205 PSIG. To restart press compressor switch from STOP/RESET to START position	See Operational Analysis Table 2 Symptom 1 High Discharge Pressure
MON.	10:00 AM	Evap. Trans. or Probe Error		Evap. Pressure Transducer or Leaving Chilled Water Thermistor (RS1)				To restart press compressor switch from STOP/RESET to START position	Defective Evap. Pressure Transducer or Leaving Chilled Water thermistor (RS1). LCWT minus saturation temperature is less than -2.5°F or greater than 25°F. Checked every 10 minutes following a 10 min. bypass at start-up.
MON.	10:00 AM	Motor Controller – Ext. Reset		CM2 or Solid State Starter (RT2)				Reset the device that caused the shutdown. Chiller will start automatically.	CM2, or Solid State Starter has shutdown chiller
MON.	10:00 AM	High Discharge Temp.		Discharge Temp. Thermistor (RT2)	220°F	219°F		To restart press compressor switch from STOP/RESET to START position.	Condenser tubes dirty or scaled or high condenser water temperature. (See Symptom 1, Table 1.)
MON.	10:00 AM	High Oil Temp.		Oil Temperature Thermistor (RT3)	170°F	169°F		To restart press compressor switch from STOP/RESET to START position	Dirty oil filter or restricted oil cooler line. Change oil filter. Refer to OPERATION ANALYSIS Table 2, Symptom 9.
MON.	10:00 AM	Power Failure	Auto-Restart	Micro Board undervoltage circuit on 5V unregulated supply	8.29VDC	7.84VDC	Optional AUTO Restart Plug is installed on Micro Board	Will restart automatically when voltage reaches 8.29VDC. An undervoltage circuit on the Micro Board monitors the 5VC unregulated supply for an undervoltage condition.	Power Failure.
MON.	10:00 AM	Power Failure		Micro Board undervoltage circuit on 5V unregulated supply	8.29VDC	7.84VDC	Auto restart plug is removed on Micro Board	To restart, press compressor switch to STOP-RESET Position and then to START position	Power Failure (Continued on page 46)

TABLE 1 – CAUSES OF NORMAL AND SAFETY SYSTEM SHUTDOWNS IN ACCORDANCE WITH THE MICROCOMPUTER CONTROL, CENTER DISPLAY

SHUTDOWN CAUSE CONTROL CENTER DISPLAY				GOVERNING CONTROL FUNCTION			PROGRAMMED SETPOINTS BY OPERATOR	START-UP OF SYSTEM AFTER SHUTDOWN	PROBABLE CAUSE AND SERVICE REQUIRED
DAY OF WEEK	TIME OF DAY	CAUSE OF SHUTDOWN	METHOD OF RESTART	DESCRIPTION	OPERATING POINT				
					ON RISE	ON FALL			
MON.	10:00 AM	Oil Pressure Transducer Error		High Oil Press. Transducer	100 PSID (Dur- ing first 7 min. of Compr. Oper.) 60 PSID (After first 7 min. of Compr. Oper.)	59 PSID		Will start at 59 PSID when compr. switch is placed to STOP/RESET and then START	This Shutdown is provided to check on Oil Pressure Transducers for failure in the high state. Replace Oil Press. Transducer in oil sump or compressor
		Vane Motor Switch Open	Autostart	Vane Motor Switch				Restart automatically after Vane Motor arm linkage is set pro- perly. Press STOP/ RESET and then START switch	Vanes are set improperly, reset vane linkage check vane positions using the SERVICE key switch and proper keys on the MicroComputer Control Center
MON.	10:00 AM	Starter Malfunction Detected		Motor Current > 15% for 10 swc. with Control Cen- ter not calling for motor to run				Press compressor STOP/RESET switch and then	Check motor starter operation. Motor current value greater than 15% FLA
MON.	10:00 AM	Program Initiated Reset	Autostart	Micro Board					Watchdog timer circuit has reset software pro- gram – Chiller will automatically restart.
		Replace RTC IC chip Reprogram Setpoints		RTC-IC chip				Reprogram the Con- trol Center Setpoints & proceed with Normal Start-up	Weak battery Replace RTC-IC chip U16
MON.	10:00 AM	Low Oil Temperature	Autostart	Oil Temp. Thermistor (RT3)	71.0°F	55°F		Press STOP/ RESET switch & then START switch	Oil Temp. Thermistor disconnected from Analog Input Board. Reconnect or replace open sensor.
MON.	10:00 AM	Faulty Dis- charge Temp. Sensor		Discharge Temp. Thermistor (RT2) discon- nected or faulty operating temp. = 32°F	30.0°F	29.9°F		Press STOP/ START switch & then START switch	Faulty Discharge Temp. Thermistor (RT2) or dis- connected from Analog Input Board. Connect or replace open sensor.
MON.	10:00 AM	Low Line Voltage (SSS Units only)		SSS Logic Board	See legend on wiring diagram			Chiller will automa- tically restart when all phases of line vol- tage increase to the minimum required starting level.	Low AC Line Voltage
MON.	10:00 AM	MTR Phase Current unbalance (SSS Units only)		SSS Logic Board	See "Section 2"			Press STOP/START switch then START switch	Motor Phase Current Unbalance

TABLE 2 – OPERATING ANALYSIS CHART

RESULTS	POSSIBLE CAUSE	REMEDY
1. SYMPTOM: ABNORMALLY HIGH DISCHARGE PRESSURE		
Temperature difference between liquid refrigerant out and water off condenser higher than normal.	Air in condenser.	
High discharge pressure.	Condenser tubes dirty or . scaled	Clean condenser tubes. Check water conditioning.
	High condenser water temperature.	Reduce condenser water inlet temperature. (Check cooling tower and water circulation.)
Temperature difference between condenser water on and water off higher than normal, with normal cooler pressure.	Insufficient condensing water flow.	Increase the quantity of water through the condenser to proper value.
2. SYMPTOM: ABNORMALLY LOW SUCTION PRESSURE		
Temperature difference between leaving chilled water and refrigerant in cooler greater than normal with high discharge temperature.	Insufficient charge of refrigerant.	Check for leaks and charge refrigerant into system.
	Flow orifice blocked.	Remove obstruction.
Temperature difference between leaving chilled water and refrigerant in the cooler greater than normal with normal discharge temperature.	Cooler tubes dirty or restricted.	Clean cooler tubes.
Temperature of chilled water too low with low motor amperes.	Insufficient load for system capacity.	Check prerotation vane motor operation and setting of low water temperature cutout.
3. SYMPTOM: HIGH COOLER PRESSURE		
High chilled water temperature.	Prerotation vanes fail to open.	Check the prerotation vane motor positioning circuit.
	System overload.	Be sure the vanes are wide open (without overloading the motor) until the load decreases.
4. SYMPTOM: NO OIL PRESSURE WHEN SYSTEM START BUTTON PUSHED		
Low oil pressure displayed on control center; compressor will not start.	Oil pump running in wrong direction.	Check rotation of oil pump (Electrical Connections).
	Oil pump not running.	Check electrical connections to oil pump and press manual reset on oil pump starter mounted on condenser shell.
5. SYMPTOM: COMPRESSOR STARTS, NORMAL OIL PRESSURE DEVELOPS, FLUCTUATES FOR SHORT WHILE, THEN COMPRESSOR STOPS ON OIL PRESSURE CUTOUT		
Oil pressure normal, fluctuates then compressor stops on Oil Pressure Cutout. Display reading LOW OIL PRESSURE .	Unusual starting conditions exist, i.e., oil foaming in reservoir and piping due to lowered system pressure.	Drain the oil from the compressor and charge new oil into the compressor. (Refer to "Charging The System With Oil", page 39.)
	Burned out oil heater.	Replace oil heater.

TABLE 2 – OPERATING ANALYSIS CHART (Continued)

RESULTS	POSSIBLE CAUSE	REMEDY
6. SYMPTOM: USUALLY HIGH OIL PRESSURE DEVELOPS WHEN OIL PUMP RUNS		
Unusually high oil pressure is displayed when the oil pressure display key is pressed when the oil pump is running.	High oil pressure. Transducer defective. Relief valve is misadjusted.	Replace low or high oil pressure transducer. Adjust external relief valve.
7. SYMPTOM: OIL PUMP VIBRATES OR IS NOISY		
Oil pump vibrates or is extremely noisy with some oil pressure when pressing OIL PRESSURE display key.	Misalignment of pump or Mounting bolts loose. Bent shaft. Worn pump parts.	Correct condition or replace faulty part.
NOTE: When oil pump is run without an oil supply it will vibrate and become extremely noisy.	Oil not reaching pump suction inlet in sufficient quantity.	Check oil supply and oil piping.
8. SYMPTOM: OIL PRESSURE GRADUALLY DECREASES (Noted by Observation of Daily Log Sheets)		
Oil pressure (noted when pressing OIL PRESSURE display key) drops to 70% of oil pressure when compressor was originally started.	Oil filter is dirty.	Change oil filter.
	Extreme bearing wear.	Inspect compressor.
9. SYMPTOM: OIL PRESSURE SYSTEM CEASES TO RETURN AN OIL/REFRIGERANT SAMPLE		
Oil refrigerant return not functioning.	Filter-drier in oil return system dirty.	Replace old filter-drier with new.
	Jet or orifice of oil return jet clogged.	Remove jet, inspect for dirt. Remove dirt using solvent and replace.
10. SYMPTOM: OIL PUMP FAILS TO DELIVER OIL PRESSURE		
No oil pressure registers when pressing OIL PRESSURE display key when oil pump runs.	Faulty oil pressure transducer Faulty wiring/connectors.	Replace oil pressure transducer.
11. SYMPTOM: REDUCED OIL PUMP CAPACITY		
Oil pump pumping capacity.	Excessive end clearance pump. Other worn pump parts.	Inspect and replace worn parts.
	Partially blocked oil supply inlet.	Check oil inlet for blockage.

SECTION 7 MAINTENANCE

RENEWAL PARTS

For any required Renewal Parts, refer to "Parts Lists" shown in "Reference Instructions", page 2.

CHECKING SYSTEM FOR LEAKS

LEAK TESTING DURING OPERATION

The refrigerant side of the system is carefully pressure tested and evacuated at the factory.

After the system is in operation under load, the high pressure components should be carefully leak tested with a leak detector to be sure all joints are tight.

If any leaks are indicated, they must be repaired immediately. Usually, leaks can be stopped by tightening flare nuts or flange bolts. However, if it is necessary to repair a welded joint, the refrigerant charge must be removed. (See "Handling Refrigerant for Dismantling and Repair", page 53.)

CONDUCTING R-22 PRESSURE TEST

With the R-22 charge removed and all known leaks repaired, the system should be charged with a small amount of R-22 mixed with dry nitrogen so that a ha-

lide torch or electronic leak detector can be used to detect any leaks too small to be found by the soap test.

To test with R-22, proceed as follows:

1. With no pressure in the system, charge R-22 gas into the system through the charging valve to a pressure of 2 psig.
2. Build up the system pressure with dry nitrogen to approximately 10 psig. To be sure that the concentration of refrigerant has reached all part of the system, slightly open the oil charging valve and test for the presence of refrigerant with a leak detector.
3. Test around each joint and factory weld. It is important that this test be thoroughly and carefully done, spending as much time as necessary and using a good leak detector.
4. To check for refrigerant leaks in the cooler and condenser, open the vents in the cooler and condenser heads and test for the presence of refrigerant. If no refrigerant is present, the tubes and tube sheets may be considered tight. If refrigerant is detected at the vents, the heads must be removed, the leak located (by means of soap test or leak detector) and repaired.

EVACUATION AND DEHYDRATION OF UNIT

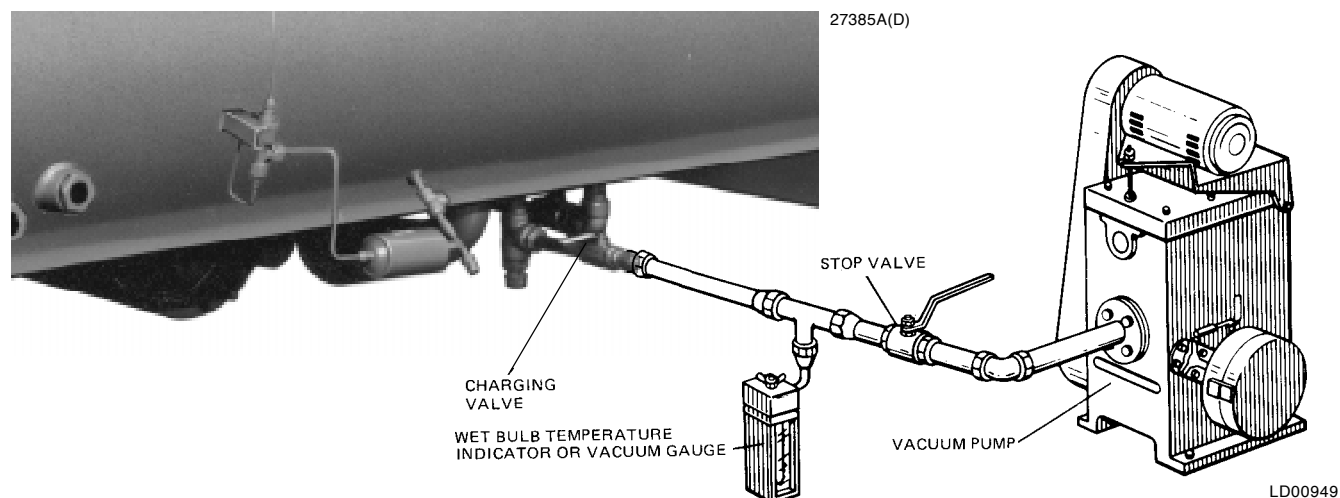

FIG. 21 – EVACUATION OF CHILLER

TABLE 3 – SYSTEM PRESSURES

*GAUGE INCHES OF MERCURY (HG) BELOW ONE STANDARD ATMOSPHERE	ABSOLUTE			BOILING TEMPERATURES OF WATER °F
	PSIA	MILLIMETERS OF MERCURY (HG)	MICRONS	
0	14.696	760.	760,000	212
10.24"	9.629	500.	500,000	192
22.05"	3.865	200.	200,000	151
25.98"	1.935	100.	100,000	124
27.95"	.968	50.	50,000	101
28.94"	.481	25.	25,000	78
29.53"	.192	10.	10,000	52
29.67"	.122	6.3	6,300	40
29.72"	.099	5.	5,000	35
29.842"	.039	2.	2,000	15
29.882"	.019	1.0	1,000	+1
29.901"	.010	.5	500	-11
29.917"	.002	.1	100	-38
29.919"	.001	.05	50	-50
29.9206"	.0002	.01	10	-70
29.921"	0	0	0	

WATER
FREEZES

*One standard atmosphere = 14.696 PSIA
 = 760 mm Hg. absolute pressure at 32°F
 = 29.921 inches Hg. absolute at 32°F

NOTES: PSIA = Lbs. per sq. in. gauge pressure
 = Pressure above atmosphere
 PSIA = Lbs. per sq. in. absolute pressure
 = Sum of gauge plus atmospheric pressure

VACUUM TESTING

After the pressure test has been completed, the vacuum test should be conducted as follows:

1. Connect a high capacity vacuum pump, with indicator, to the system charging valve as shown in Fig. 22 and start the pump. (See "Vacuum Dehydration".)
2. Open wide all system valves, including the purge and gauge valves. Be sure all valves to the atmosphere are closed.
3. Operate the vacuum pump in accordance with VACUUM DEHYDRATION until a wet bulb temperature of +32°F or a pressure of 5 mm Hg is reached. See Table 3 for corresponding values of pressure.
4. To improve evacuation circulate hot water (not to exceed 125°F) through the cooler and condenser tubes to thoroughly dehydrate the shells. If a source of hot water is not readily available, a portable water heater should be employed. DO NOT USE STEAM. A suggested method is to connect a hose between the source of hot water under pressure and the cooler head drain connection, out the cooler

vent connection, into the condenser head drain and out the condenser vent. To avoid the possibility of causing leaks, the temperature should be brought up slowly so that the tubes and shell are heated evenly.

5. Close the system charging valve and the stop valve between the vacuum indicator and the vacuum pump. Then disconnect the vacuum pump leaving the vacuum indicator in place.
6. Hold the vacuum obtained in Step 3 in the system for 8 hours; the slightest rise in pressure indicates a leak or the presence of moisture, or both. If, after 8 hours the wet bulb temperature in the vacuum indicator has not risen above 40°F or a pressure of 6.3 mm Hg, the system may be considered tight.

NOTE: Be sure the vacuum indicator is valved off while holding the system vacuum and be sure to open the valve between the vacuum indicator and the system when checking the vacuum after the 8 hour period.

7. If the vacuum does not hold for 8 hours within the limits specified in Step 6 above, the leak must be found and repaired.

VACUUM DEHYDRATION

To obtain a sufficiently dry system, the following instructions have been assembled to provide an effective method for evacuating and dehydrating a system in the field. Although there are several methods of dehydrating a system, we are recommending the following, as it produces one of the best results, and affords a means of obtaining accurate readings as to the extent of dehydration.

The equipment required to follow this method of dehydration consists of a wet bulb indicator or vacuum gauge, a chart showing the relation between dew point temperature and pressure in inches of mercury (vacuum), (see Table 3) and a vacuum pump capable of pulling to a suitable vacuum on the system.

OPERATION

Dehydration of a refrigerant system can be obtained by this method because the water present in the system reacts much as a refrigerant would. By pulling down the pressure in the system to a point where its saturation temperature is considerably below that of room temperature, heat will flow from the room through the walls of the system and vaporize the water, allowing a large percentage of it to be removed by the vacuum pump. The length of time necessary for the dehydration of a system is dependent on the size or volume of the system, the capacity and efficiency of the vacuum pump, the room temperature and the quantity of water present in the system. By the use of the vacuum indicator as suggested, the test tube will be evacuated to the same pressure as the system, and the distilled water will be maintained at the same saturation temperature as any free water in the system, and this temperature can be observed on the thermometer.

If the system has been pressure tested and found to be tight prior to evacuation, then the saturation temperature recordings should follow a curve similar to the typical saturation curve shown as Fig. 22.

The temperature of the water in the test tube will drop as the pressure decreases, until the boiling point is reached, at which point the temperature will level off and remain at this level until all of the water in the shell is vaporized. When this final vaporization has taken place the pressure and temperature will continue to drop until eventually a temperature of 35°F or a pressure of 5 mm Hg. is reached.

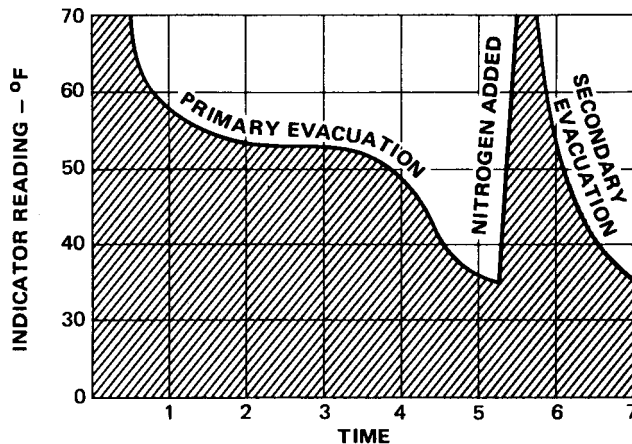

LD00474

FIG. 22 – SATURATION CURVE

When this point is reached, practically all of the air has been evacuated from the system, but there is still a small amount of moisture left. In order to provide a medium for carrying this residual moisture to the vacuum pump, nitrogen should be introduced into the system to bring it to atmospheric pressure and the indicator temperature will return to approximately ambient temperature. Close off the system again, and start the second evacuation.

The relatively small amount of moisture left will be carried out through the vacuum pump and the temperature or pressure shown by the indicator should drop uniformly until it reaches a temperature of 35°F or a pressure of 5 mm Hg.

When the vacuum indicator registers this temperature or pressure, it is a positive sign that the system is evacuated and dehydrated to the recommended limit. If this level cannot be reached, it is evident that there is a leak somewhere in the system. Any leaks must be corrected before the indicator can be pulled down to 35°F or 5 mm Hg. in the primary evacuation.

During the primary pull-down, keep a careful watch on the wet bulb indicator temperature, and do not let it fall below 35°F. If the temperature is allowed to fall to 32°F, the water in the test tube will freeze, and the result will be a faulty temperature reading.

REFRIGERANT CHARGING

To avoid the possibility of freezing liquid within the cooler tubes when charging an evacuated system, only refrigerant vapor from the top of the drum or cylinder must be admitted to the system pressure until the system pressure is raised above the point corresponding to the freezing point of the cooler liquid. For water, the pressure corresponding to the freezing point is 57.5 PSIG for R-22 or 8.54 PSIG for R-134a (at sea level).

While charging, every precaution must be taken to prevent moisture laden air from entering the system. Make up a suitable charging connection from new copper tubing to fit between the system charging valve and the fitting on the charging drum. This connection should be as short as possible but long enough to permit sufficient flexibility for changing drums. The charging connection should be purged each time a full container of refrigerant is connected and changing containers should be done as quickly as possible to minimize the loss of refrigerant.

Refrigerant may be furnished in drums containing either 30, 50, 125 or 1750 lbs. of refrigerant. These drums are not returnable and they should be stored for future use if it should ever become necessary to remove refrigeration from the system.

TABLE 4 – REFRIGERANT CHARGE

R-22			R-134a		
SHELL CODES		LBS.	SHELL CODES		LBS.
COOLER	COND.		COOLER	COND.	
M	M	1,425	L	L	1,150
M	N	1,600	L	M	1,150
N	M	1,675	M	L	1,400
N	N	1,800	M	M	1,400
N	P	1,800	M	N	1,585
P	N	1,875	N	M	1,650
P	P	1,875	N	N	1,805
P	Q	2,175	N	P	1,805
Q	P	2,225	P	N	1,900
Q	Q	2,500	P	P	1,900
Q	R	2,800	P	Q	2,205
R	Q	3,050	Q	P	2,235
R	R	3,300	Q	Q	2,515
R	S	3,500	Q	R	2,800
S	R	3,500	R	Q	3,075
S	S	3,500	R	R	3,325
			R	S	3,450
			S	R	3,450
			S	S	3,575

CHECKING THE REFRIGERANT CHARGE DURING UNIT SHUTDOWN

The refrigerant charge is specified for each chiller model (see Table 4). Charge the correct amount of refrigerant and record the level in the cooler sight glass.

The refrigerant charge should always be checked and trimmed when the system is shut down.

The refrigerant charge level must be checked after the pressure and temperature have equalized between the

condenser and cooler. This would be expected to be 4 hours or more after the compressor and water pumps are stopped. The level should be at the center of the sight glass $\pm 1/4$ inch.

Charge the refrigerant in accordance with the method shown under the "Refrigerant Charging", above. The refrigerant level should be observed and the level recorded after initial charging.

HANDLING REFRIGERANT FOR DISMANTLING AND REPAIRS

If it becomes necessary to open any part of the refrigerant system for repairs, it will be necessary to remove the charge before opening any part of the unit.

MEGGING THE MOTOR

While the main disconnect switch and compressor motor starter are open, meg the motor as follows:

1. Using a megohm meter (megger), meg between phases and each phase to ground (see Fig. 23); these readings are to be interpreted using the graph shown in Fig. 24.

2. If readings fall below shaded area, remove external leads from motor and repeat test.

NOTE: Motor is to be megged with the starter at ambient temperature after 24 hours of idle standby.

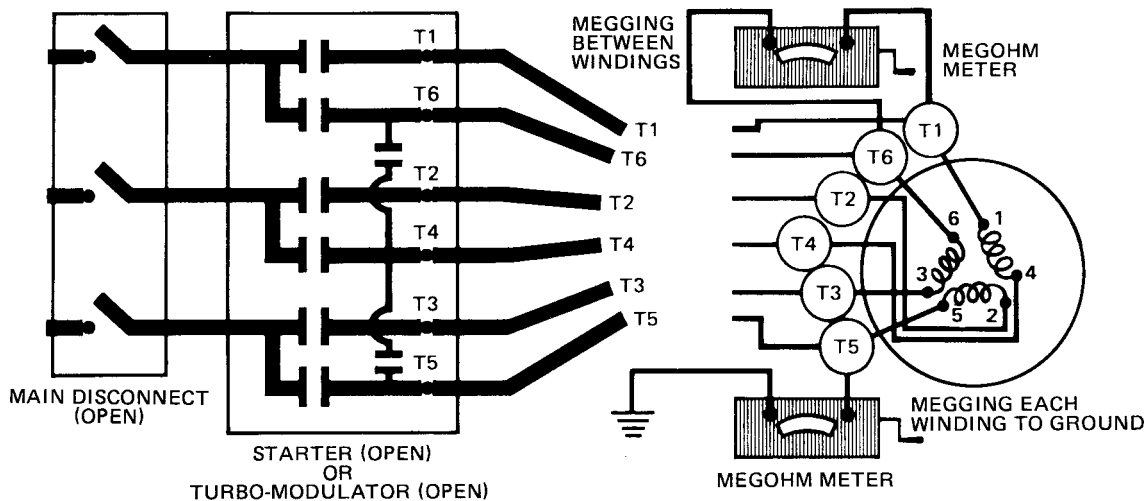

LD00475

FIG. 23 – DIAGRAM, MEGGING MOTOR WINDINGS

FIG. 24 - MOTOR STATOR TEMPERATURE AND INSULATION RESISTANCES

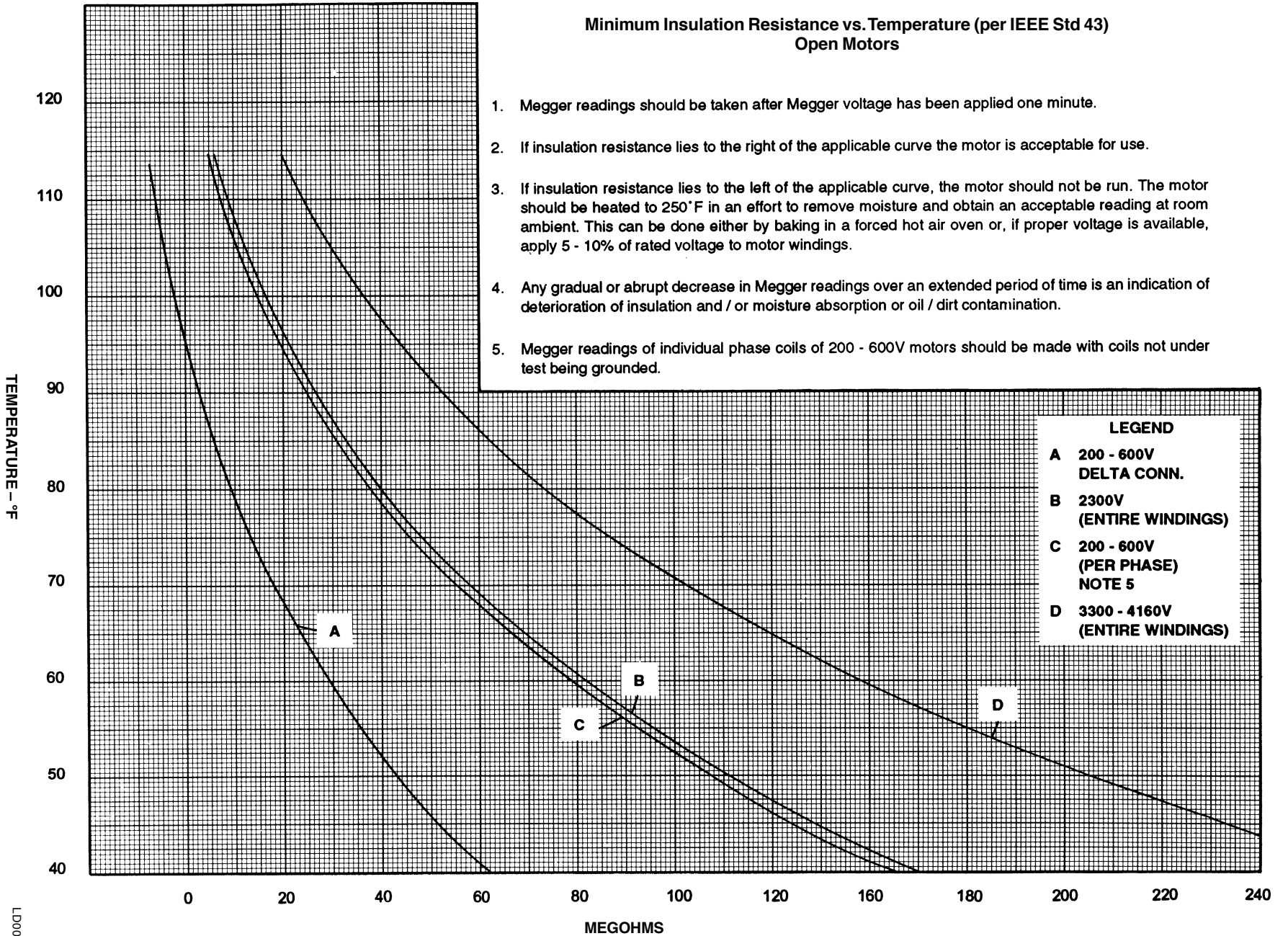

LD00476

CONDENSERS AND COOLERS

GENERAL

Maintenance of condenser and cooler shells is important to provide trouble free operation of the chiller. The water side of the tubes in the shell must be kept clean and free from scale. Proper maintenance such as tube cleaning, and testing for leaks, is covered on the following pages.

CHEMICAL WATER TREATMENT

Since the mineral content of the water circulated through coolers and condensers varies with almost every source of supply, it is possible that the water being used may corrode the tubes or deposit heat resistant scale in them. Reliable water treatment companies are available in most larger cities to supply a water treating process which will greatly reduce the corrosive and scale forming properties of almost any type of water.

As a preventive measure against scale and corrosion and to prolong the life of cooler and condenser tubes, a chemical analysis of the water should be made preferably before the system is installed. A reliable water treatment company can be consulted to determine whether water treatment is necessary, and if so, to furnish the proper treatment for the particular water condition.

CLEANING COOLER AND CONDENSER TUBES

COOLER

It is difficult to determine by any particular test whether possible lack of performance of the water cooler is due to fouled tubes alone or due to a combination of troubles. Trouble which may be due to fouled tubes is indicated when, over a period of time, the cooling capacity decreases and the split (temperature difference between water leaving the cooler and the refrigerant temperature in the cooler) increases. A gradual drop-off in cooling capacity can also be caused by a gradual leak of refrigerant from the system or by a combination of fouled tubes and shortage of refrigerant charge. An excessive quantity of oil in the cooler can also contribute to erratic performance.

CONDENSER

In a condenser, trouble due to fouled tubes is usually indicated by a steady rise in head pressure, over a period of time, accompanied by a steady rise in condensing temperature, and noisy operation. These symptoms may also be due to foul gas buildup. Purging will remove the foul gas revealing the effect of fouling.

TUBE FOULING

Fouling of the tubes can be due to deposits of two types as follows:

1. Rust or sludge – which finds its way into the tubes and accumulates there. This material usually does not build up on the inner tube surfaces as scale, but does interfere with the heat transfer. Rust or sludge can generally be removed from the tubes by a thorough brushing process.
2. Scale – due to mineral deposits. These deposits, even though very thin and scarcely detectable upon physical inspection, are highly resistant to heat transfer. They can be removed most effectively by circulating an acid solution through the tubes.

TUBE CLEANING PROCEDURES

BRUSH CLEANING OF TUBES

If the tube consists of dirt and sludge, it can usually be removed by means of the brushing process. Drain the water sides of the circuit to be cleaned (cooling water or chilled water) remove the heads and thoroughly clean each tube with a soft bristle bronze brush. **DO NOT USE A STEEL BRISTLE BRUSH.** A steel brush may damage the tubes.

Improved results can be obtained by admitting water into the tube during the cleaning process. This can be done by mounting the brush on a suitable length of 1/8" pipe with a few small holes at the brush end and connecting the other end by means of a hose to the water supply.

The tubes should always be brush cleaned before acid cleaning.

ACID CLEANING OF TUBES

If the tubes are fouled with a hard scale deposit, they must be acid cleaned. It is important that before acid cleaning, the tubes be cleaned by the brushing process described above. If the relatively loose foreign material is removed before the acid cleaning, the acid solution will have less material to dissolve and flush from the tubes with the result that a more satisfactory cleaning job will be accomplished with a probable saving of time.

COMMERCIAL ACID CLEANING

In many major cities, commercial organizations now offer a specialized service of acid cleaning coolers and condensers. If acid cleaning is required, YORK

recommends the use of this type of organization. The Dow Industries Service Division of the Dow Chemical Company, Tulsa, Oklahoma, with branches in principal cities is one of the most reliable of these companies.

TESTING FOR COOLER AND CONDENSER TUBE LEAKS

Cooler and condenser tube leaks in R-22 or R-134a systems may result in refrigerant leaking into the water circuit, or water leaking into the shell depending on the pressure levels. If refrigerant is leaking into the water, it can be detected at the liquid head vents after a period of shutdown. If water is leaking into the refrigerant, system capacity and efficiency will drop off sharply. If a tube is leaking and water has entered the system, the cooler and condenser should be valved off from the rest of the water circuit and drained immediately to prevent severe rusting and corrosion. If a tube leak is indicated, the exact location of the leak may be determined as follows:

1. Remove the heads and listen at each section of tubes for a hissing sound that would indicate gas leakage. This will assist in locating the section of tubes to be further investigated. If the probable location of the leaky tubes has been determined, treat that section in the following manner (if the location is not definite, all the tubes will require investigations).
2. Wash off both tube heads and the ends of all tubes with water.

NOTE: Do not use carbon tetrachloride for this purpose since its fumes give the same flame discoloration that the refrigerant does.

3. With nitrogen or dry air, blow out the tubes to clear them of traces of refrigerant laden moisture from the circulation water. As soon as the tubes are clear, a cork should be driven into each end of the tube. Repeat this with all of the other tubes in the suspected section or if necessary, with all the tubes in the cooler or condenser. Allow the cooler or condenser to remain corked up to 12 to 24 hours before proceeding. Depending upon the amount of leakage, the corks may blow from the end of a tube, indicating the location of the leakage. If not, it will be necessary to make a very thorough test with the leak detector.
4. After the tubes have been corked for 12 to 24 hours, it is recommended that two men working at both ends of the cooler carefully test each tube – one man removing corks at one end and the other at the opposite end to remove corks and handle the leak detector. Start with the top row of tubes in the section being investigated, remove the corks at the ends of one tube simultaneously and insert the exploring tube for 5 seconds – this should be long enough to draw into the detector any refrigerant gas that might have leaked through the tube walls. A fan placed at the end of the cooler opposite the detector will assure that any leakage will travel through the tube to the detector.
5. Mark any leaking tubes for later identification.
6. If any of the tube sheet joints are leaking, the leak should be indicated by the detector. If a tube sheet leak is suspected, its exact location may be found by using a soap solution. A continuous buildup of bubbles around a tube indicates a tube sheet leak.

COMPRESSOR

Maintenance for the compressor assembly consists of checking the operation of the oil return system and changing the dehydrator, checking and changing the oil, checking and changing the oil filters, checking the operation of the oil heater, checking the operation of the oil pump, and observing the operation of the compressor.

Internal wearing of compressor parts could be a serious problem caused by improper lubrication, brought

about by restricted oil lines, passages, or dirty oil filters. If the unit is shutting down on (HOT) High Oil Temperature or Low Oil Pressure (OP), change the oil filter element. Examine the oil filter element for the presence of aluminum particles. If aluminum particles are noticeable and the same conditions continue to stop the unit operation after a new filter element is installed, notify the nearest YORK office to request the presence of a YORK Service man.

ELECTRICAL CONTROLS

For information covering the MicroComputer Control Center operation, refer to "Section 2".

The operating points of the pressure and temperature cut outs are shown in the Wiring Diagrams. These diagrams also contain a starting and stopping sequence diagram.

SECTION 8

PREVENTIVE MAINTENANCE

It is the responsibility of the owner to provide the necessary daily, monthly and yearly maintenance requirements of the system. *IMPORTANT – If a unit failure occurs due to improper maintenance during the warranty period; YORK will not be liable for costs incurred to return the system to satisfactory operation.*

In any operating system it is most important to provide a planned maintenance and inspection of its functioning parts to keep it operating at its peak efficiency. Therefore, the following maintenance should be performed when prescribed.

COMPRESSOR

1. Oil Filter – The oil filter must be changed when the oil pressure drops 30% or semi-annually if not required earlier.

When the oil filter is changed, it should be inspected thoroughly for any aluminum particles which would indicate possible bearing wear. If aluminum particles are found this should be brought to the attention of the nearest YORK office for their further investigation and recommendations.

2. Oil Changing – The oil in the compressor must be changed annually or earlier if it becomes dark or cloudy.

COMPRESSOR MOTOR

1. Check motor mounting screws frequently to insure tightness.
2. Meg motor windings annually to check for deterioration of windings.

PRESSURE TESTING

The unit should be pressure tested annually. Any leaks found must be repaired immediately. Air and moisture are the worst enemies of these systems and experience has shown that units which are maintained tight, are systems that provide trouble free efficient operation.

COOLER AND CONDENSER

The major portion of maintenance on the condenser and cooler will deal with the maintaining the water side of the condenser and cooler in a clean condition.

The use of untreated water in cooling towers, closed water systems, etc. frequently results in one or more of the following:

1. Scale Formation.
2. Corrosion or Rusting.
3. Slime and Algae Formation.

It is therefore to the benefit of the user to provide for proper water treatment to provide for a longer and more economical life of the equipment. The following recommendation should be followed in determining the condition of the water side of the condenser and cooler tubes.

1. The condenser tubes should be cleaned annually or earlier if conditions warrant. If the temperature difference between the water off the condenser and the condenser liquid temperature is more than 4° greater than the difference recorded on a new unit, it is a good indication that the condenser tubes require cleaning. They should be cleaned as instructed on pages 38 to 39 of this manual.
2. The cooler tubes under normal circumstances will not require cleaning. If however the temperature difference between the refrigerant and the chilled water increases slowly over the operating season, it is an indication that the cooler tubes may be fouling or that there may be a water by-pass in the water box requiring gasket replacement or refrigerant may have leaked from the chiller.

OIL RETURN SYSTEM

1. Change the dehydrator in the oil return system semi-annually or earlier if the oil return system fails to operate.
2. When the dehydrator is changed, the nozzle of the

eductor should be checked for any foreign particles that may be obstructing the jet.

ELECTRICAL CONTROLS

1. All electrical controls should be inspected for obvious malfunctions.
2. It is important that the factory settings of controls (operation and safety) not be changed. If the settings are changed without YORK's approval, the warranty will be jeopardized.
3. A 5-11 year life battery is part of the RTC-Real Time Clock. To replace, refer to page 29.

