

24679
FIG. 6 — DIGITAL INPUT BOARD

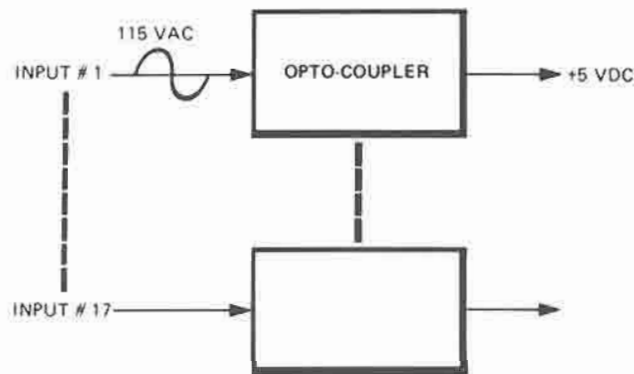

FIG. 7 — DIGITAL INPUT BOARD SIMPLIFIED BLOCK DIAGRAM

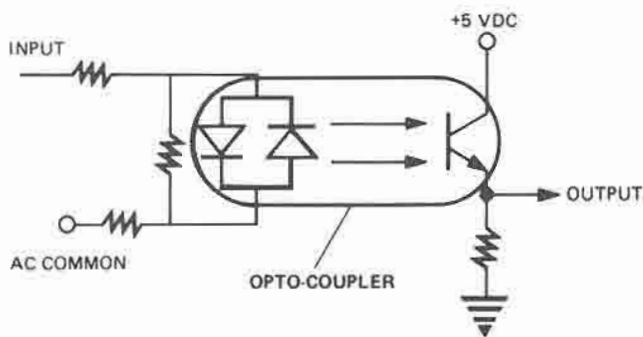

FIG. 8 — DETAILED SCHEMATIC REPRESENTATION DIGITAL INPUT-BOARD

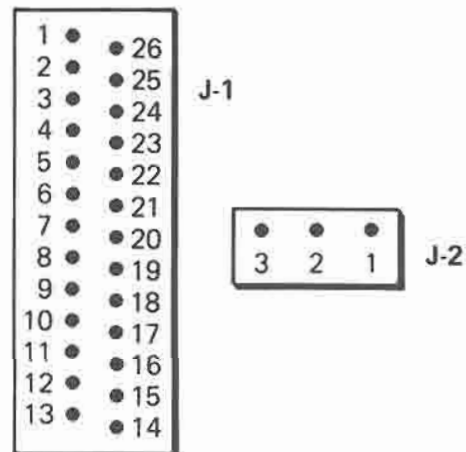

FIG. 9 — DIGITAL INPUT BOARD-PIN IDENTIFICATION

Connector J1 is provided to connect the logic level outputs of the Digital Input Board to the Micro Board via ribbon cable.

DIGITAL INPUT BOARD — INPUTS

J2-1 — Motor controller contacts (CM) input. From current module (CM-2) or Liquid Cooled Solid State Starter. 0VAC when motor controller has initiated a shutdown. When motor controller has reset, input goes to 115 VAC. Typically, the motor controller device must be manually

reset to clear this signal. However, the following motor controller shutdowns do not require an external reset:

Liquid Cooled Solid State Starter — High temp (>110°F), trigger OOL, phase rot/loss, power fault and half phase.

Electro-Mechanical Starter — (Current Module-CM2) — power fault.

When the motor controller device has detected a "Power Fault", the motor controller contacts will open and reclose in less than 3 seconds. Any reclosure in less than 3 seconds will be interpreted by the control center as a power fault. Power fault shutdowns do not require an external reset before restarting chiller; the chiller automatically restarts.

J2-2 — Compressor switch "STOP" position input. 115 VAC when switch is in "STOP" position, otherwise 0VAC.

J2-3 - Compressor switch "START" position input. 115VAC when switch is in "START" position, otherwise 0VAC.

TB1 – TERMINAL BLOCK

TB1-71 — Not used.

TB1-70 — Not used.

TB1-32 — High pressure safety input. This function is provided by a pressure control mounted on the condenser shell. 115 VAC when condenser pressure rises to 265 PSIG. High pressure safety device resets when condenser pressure falls to 205 PSIG.

TB1-18 — Vane motor switch input. 115VAC when vanes are fully closed.

TB1-11 — Not used.

TB1-10—Low evaporator pressure safety input on brine applications only. 0 VAC when external LEP safety device senses a low pressure situation, otherwise, 115 VAC. The actual trip setting of the safety device is determined by the specific application.

TB1-31—Auxilliary safety shutdown input. This input is used as a general purpose safety shutdown input available for customer use. Apply 115 VAC to initiate a shutdown. Ref. Fig. 10.

TB1-1—115 VAC input from Control Center AC power.

TB1-2—115 VAC neutral input from Control Center AC power.

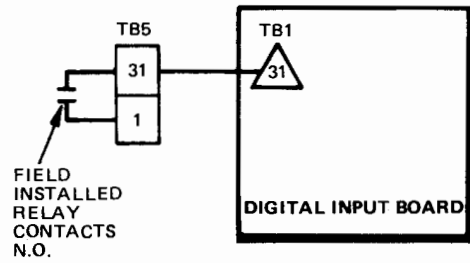

FIG. 10 – AUXILIARY SAFETY SHUTDOWN INPUT - TYPICAL APPLICATION

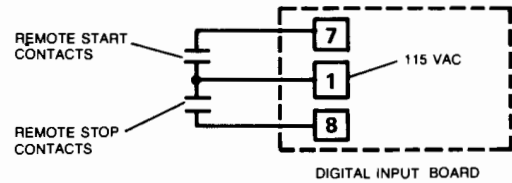

FIG. 11 – REMOTE START AND STOP UNITS

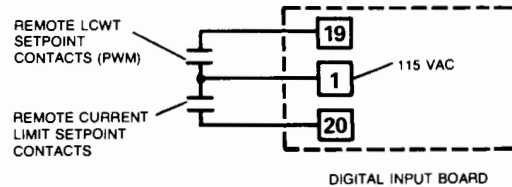

FIG. 12 – REMOTE LCWT & CURRENT LIMIT SET-POINT INPUTS (PWM)

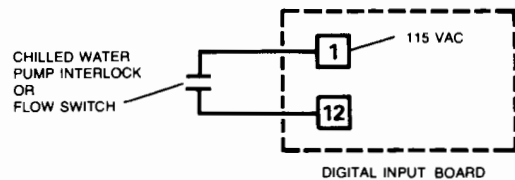
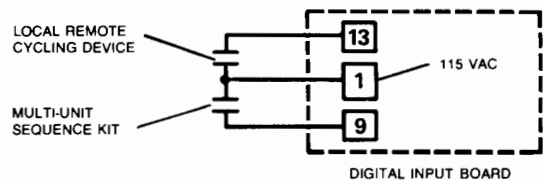
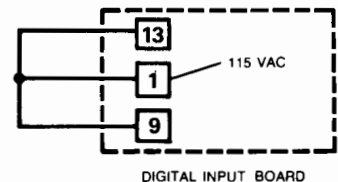

FIG. 13 – CHILLED WATER PUMP INTERLOCK OR FLOW SWITCH CONTACTS



DETAIL A



NO LOCAL OR REMOTE CYCLING OR MULTI UNIT SEQUENCE

DETAIL B

FIG. 14 – LOCAL REMOTE CYCLE DEVICE & MULTI-UNIT SEQUENCE KIT INPUTS

TB2—TERMINAL BLOCK

TB2-7 — Remote start input from external Energy Management System (EMS). Input designed to accept 115 VAC from external field supplied contacts to start compressor. Input will only be accepted if Control Center is in **REMOTE** mode and panel "**COMPRESSOR**" switch is in **RUN** mode. Refer to Fig. 11. This signal need only be a momentary signal to initiate a start, but a maintained closure is recommended.

TB2-1 — Connected to 115 VAC on Digital Input Board. Source voltage for remote start and remote stop inputs. Refer to Fig. 11.

TB2-8—Remote stop input from external Energy Management System (EMS). Input designed to accept 115 VAC from external field supplied contacts to stop compressor. Input will only be accepted if Control Center is in **REMOTE** mode and panel "**COMPRESSOR**" switch is in the **RUN** mode. Refer to Fig. 11. This signal must be a maintained signal to provide a stop function.

TB2-19—Remote LCWT setpoint from external Energy Management System (EMS). Signal is a 1-11 SEC. Pulse Width Modulated (PWM) signal as follows: A 1 second application of 115 VAC corresponds to the Control Center operator programmed **CHILLED LIQUID TEMP** setpoint . . . An 11 second application of 115 VAC corresponds to the maximum allowable remote reset value, 10°F or 20°F (Refer to description of **REMOTE RESET TEMP RANGE**). All settings between 1 sec. and 11 sec. are linearly scaled. Refer to Fig. 12. Input will only be accepted if Control Center is in **REMOTE** mode. Calculate the setpoint as follows:

$$^{\circ}\text{F Offset} = \frac{(\text{Pulse Width} - 1) (\text{Remote Reset Temp Range})}{10}$$

$$\text{Setpoint} = \text{Keypad Entered Setpoint} + ^{\circ}\text{F Offset}$$

TB2-1—Connected to 115 VAC on Digital Input Board. Source voltage for remote LCWT setpoint (PWM signal) and remote current limit setpoint (PWM signal). Refer to Fig. 12.

TB2-20—Remote current limit setpoint from external Energy Management System (EMS). Signal is a 1-11 sec. Pulse Width Modulated (PWM) signal as follows: A 1 second application of 115 VAC corresponds to a setting of 100% FLA . . . an 11 second application of 115 VAC corresponds to a setting of 40% FLA. All settings between 1 sec. and 11 sec. are linearly scaled. Input will only be accepted when Control Center is in **REMOTE** mode. Refer to Fig. 12. Calculate the setpoint as follows:

$$\text{Setpoint} = 100\% [(\text{Pulsewidth} - 1) 6\%]$$

TB2-1—Connected to 115 VAC on Digital Input Board. Source voltage for chilled water pump interlock/flow switch inputs. Refer to Fig. 13.

TB2-12 — Chilled water pump interlock or flow switch contacts input. 115 VAC when interlock or water flow is established. This condition is a prerequisite to running the compressor. Refer to Fig. 13.

TB2-1 —Connected to 115 VAC on digital input board. Source voltage for Local/Remote Cycling Device Input and multi-unit sequence input. Refer to Fig. 14 (Details A & B).

TB2-9—Multi-unit sequence kit input. 115 VAC when sequence kit enables the compressor to run. If no multi-unit sequence kit is provided, this input must be jumpered as shown in Fig. 14, Detail B. "**COMPRESSOR**" switch must be in **RUN** ition to enable input. Refer to Fig. 14 (Details A & B).

TB2-13—Remote/local cycling device input. 115 VAC when remote device enables the compressor to run. If no cycling device is provided, this input must be jumpered as shown. Compressor switch must be in "Run" position. to enable input. Refer to Fig. 14 (Details A & B).

DIGITAL INPUT BOARD — OUTPUTS

All outputs are +5VDC in the active state. In other words, a 115 VDC input signal causes a +5VDC output level on the corresponding board output. A 0VAC input causes a 0VDC output. All outputs interface to the micro board via ribbon cable.

- J1-1 - Vane Motor Switch
- 2 - HP Safety,
- 3|-|Not Used
- 4|- Not Used
- 5 - Not Used
- 6 - Not Used
- 7 - Motor Controller
- 8 - Stop (Local)
- 9 - Start (Local)
- 10 - Not Used
- 11 - Not Used
- 12 - Not Used
- 13 - 5V Return
- 14 - +5V Regulated
- 15 - Remote Start
- 16 - Remote Stop
- 17 - Remote LCWT Setpoint
- 18 - Remote Current Limit Setpoint
- 19 - Flow Switch
- 20 - Local/Remote Cycling Device
- 21 - Multi-Unit Sequence
- 22 - Not Used
- 23 - Not Used
- 24 - Aux. Safety Shutdown
- 25 - LEP (Brine Units Only)
- 26 - Not Used

SECTION 3B RELAY OUTPUT BOARD

(Ref. 15 & 16)

The Relay Output Board allows the Micro Board to be interfaced to 115 VAC output signals. Ten board-mounted relays are driven by the micro board. One side of each relay coil is connected to +12VDC regulated power. The other side of the coil is connected to the input connector J1. The Micro Board is connected to this connector and it drives the appropriate pin to ground potential when it wants to energize a selected relay. The contacts (N.O.) of each relay are interfaced, via Terminal blocks TB3 and TB4, to various external relays and solenoids.

Terminal block TB3 is provided for interfacing the system start relay, the system stop relay, selected system safeties, system solenoids and the vane motor. The water temperature control circuits that control the vane motor are located on the micro board. These circuits control two triacs located on the relay output board; one to open the vanes and one to close the vanes. The triacs are then interfaced to the open and close windings of the vane motor.

Terminal block TB4 is provided for field interface of system status contact closures & chilled water pump contacts.

RELAY OUTPUT BOARD – INPUTS

All inputs are logic low in the active state. A logic low input to this board causes the output relay to energize. A +12VDC input causes the output relay to de-energize. All inputs interface from the micro board.

- J1-1 - Cycling Shutdown
- J1-2 - Safety Shutdown
- J1-3 - Chilled Water Pump
- J1-4 - Remote Mode Ready to Start
- J1-5 - Motor Starter—Start
- J1-6 - High Speed Thrust Solenoid
- J1-7 - Oil Return Solenoid
- J1-8 - Motor Starter - Stop
- J1-9 - Vent Line & Liquid Line Solenoid
- J1-10 - Oil Pump
- J1-11 - PRV Close*
- J1-12 - PRV Close*
- J1-13 - PRV Open**

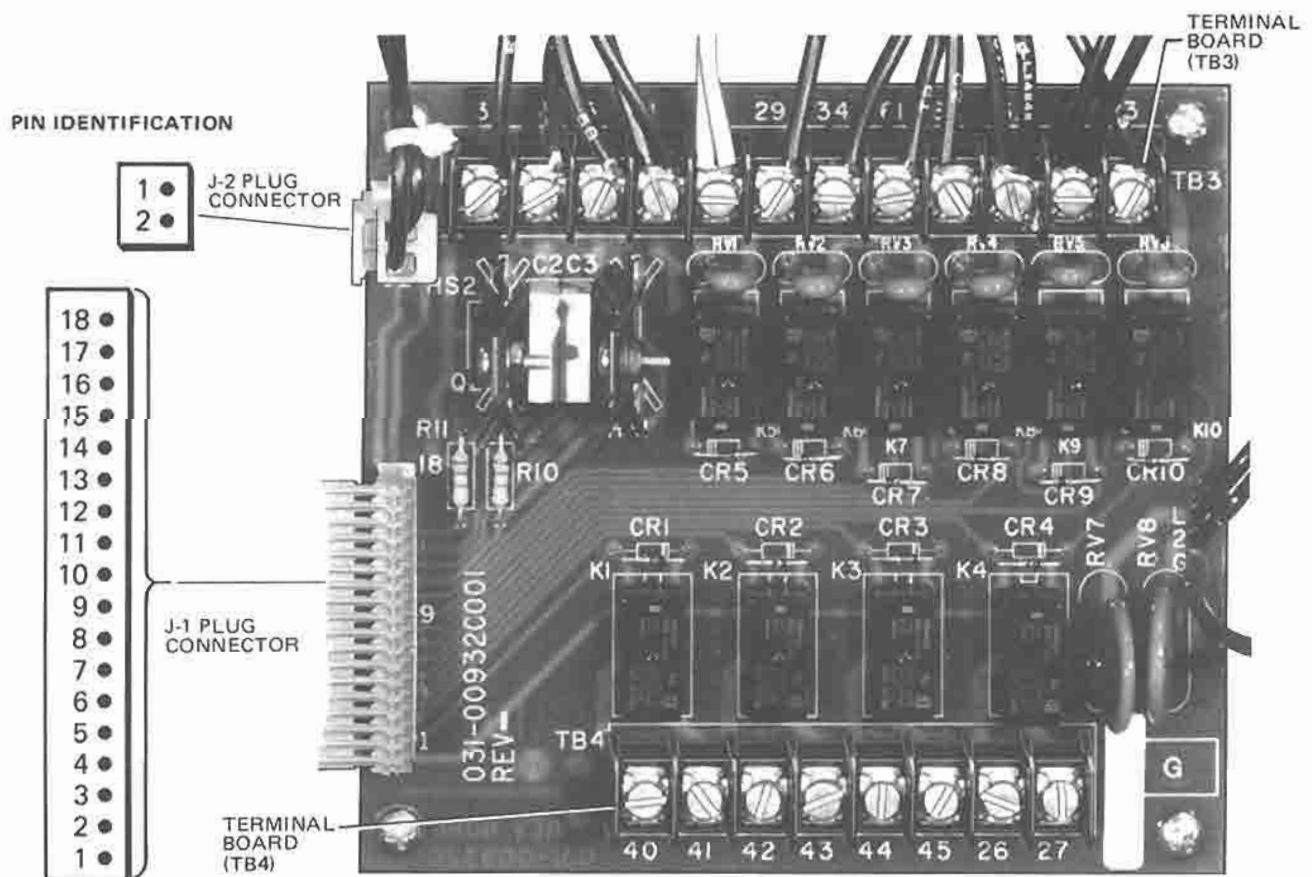

24680

FIG. 15 – RELAY OUTPUT BOARD

- J1-14 - PRV Open**
- J1-15 - Not Used
- J1-16 - Not Used
- J1-17 - +12VDC Return
- J1-18 - +12VDC Return
- J2-1 - +12VDC Return
- J2-2 - +12VDC
- TB3-1 - 115VAC
- TB3-2 - 115VAC Neutral

*PRV Close - 0VAC as measured from J1-11 to J1-12 when Micro Board is commanding the vanes to close. Approx. 24VAC—28VAC when vanes are holding or opening.

**PRV Open - 0VAC as measured from J1-13 to J1-14 when Micro Board is commanding the vanes to open. Approx. 24VAC—28VAC when vanes are holding or closing.

RELAY OUTPUT BOARD – OUTPUTS

- TB3-59 - PRV Common
- TB3-3 - PRV Motor winding. 0VAC measured to TB3-59 when vanes are opening. Approx. 24VAC—28VAC when vanes are holding or closing.
- TB3-58 - PRV Motor close winding. 0VAC measured to TB3-59 when vanes are closing. Approx. 24VAC—28VAC when vanes are holding or opening.
- TB3-29 - Oil pump starter contacts. 115VAC when Micro Board is commanding the oil pump to run.

TB3-34 — Vent line solenoid and liquid line solenoid valve contacts. 115 VAC when Micro Board is commanding the solenoid valves to open.

TB3-6 — Motor starter contacts (Ref. Fig. 17). Part of 1R (start relay) anti-chatter circuit. After the 30 second pre-lube (**START SEQUENCE INITIATED**) the Micro Board energizes K9 and K10 coincident with the Micro Board going into “RUN” mode (**SYSTEM RUN-LEAVING TEMP CONTROL**). 1R is energized thru K9 contacts causing 1R-4 contacts to close creating a holding circuit thru 1R-4 and K10 contacts. After 200 milliseconds, the Micro Board de-energizes K9. 1R remains energized thru 1R-4 and K10 contacts. If 1R fails to energize or if it de-energizes at any time while the Micro Board is in **SYSTEM RUN-LEAVING TEMP CONTROL** , 1R cannot again energize until K9 is again energized at completion of **START SEQUENCE INITIATED** (the next chiller start). When 1R de-energizes while **SYSTEM RUN-LEAVING TEMP CONTROL** is displayed the Micro Board senses a loss of motor current (for 25 continuous seconds) and shuts down the chiller and displays **AC UNDER-VOLTAGE AUTOSTART** . Refer to explanation of this message in Operating Manual Form 160.49-O1.

TB3-16 - Motor controller input. 115VAC when motor controller device is satisfied. Otherwise, 0VAC.

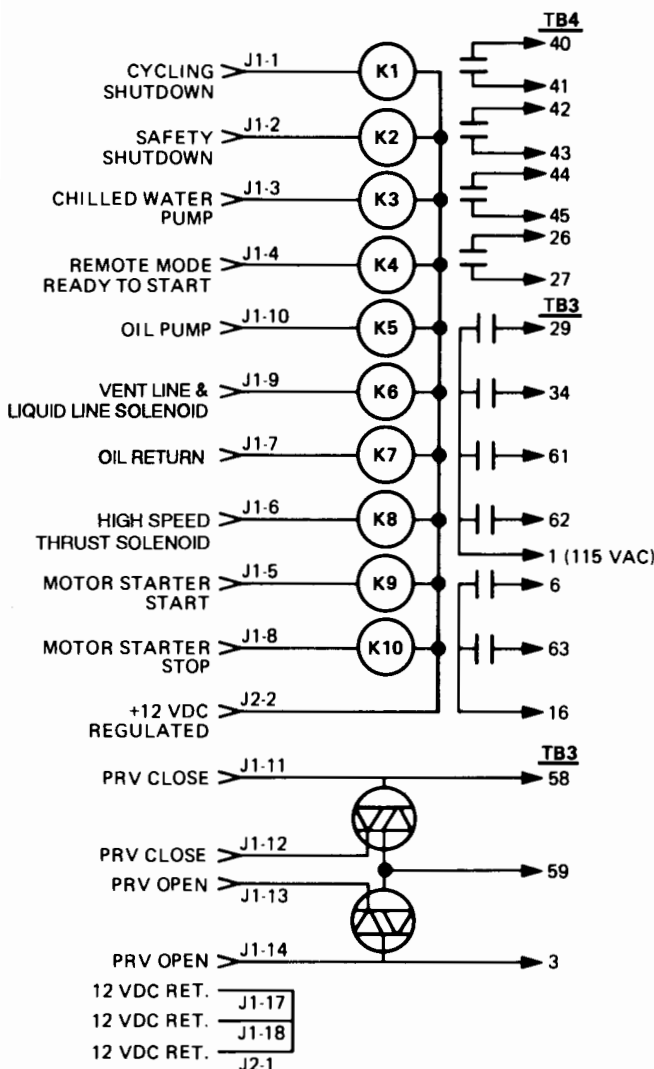

FIG. 16 – RELAY OUTPUT BOARD SIMPLIFIED SCHEMATIC DIAGRAM

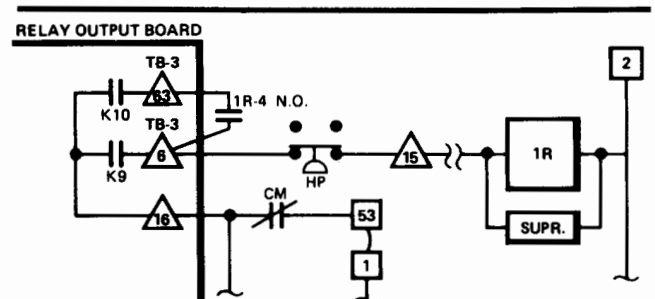

FIG. 17 – RELAY OUTPUT BOARD