

Table of Contents

Introduction	2
AC Motors	4
Force and Motion	6
AC Motor Construction	12
Magnetism	17
Electromagnetism	19
Developing a Rotating Magnetic Field	24
Rotor Rotation.....	29
Motor Specifications.....	34
NEMA Motor Characteristics.....	37
Derating Factors	43
AC Motors and AC Drives.....	45
Matching Motors to the Load	49
Motor Enclosures	53
Mounting	56
Siemens AC Induction Motors.....	61
Review Answers	72
Final Exam	74

Introduction

Welcome to another course in the STEP series, **Siemens Technical Education Program**, designed to prepare our distributors to sell Siemens Industry, Inc. products more effectively. This course covers **Basics of AC Motors** and related products.

Upon completion of **Basics of AC Motors** you should be able to:

- Explain the concepts of force, inertia, speed, and torque
- Explain the difference between work and power
- Describe the construction of a squirrel cage AC motor
- Describe the operation of a rotating magnetic field
- Calculate synchronous speed, slip, and rotor speed
- Plot starting torque, accelerating torque, breakdown torque, and full-load torque on a NEMA torque curve
- Apply derating factors as required by an application
- Describe the relationship between V/Hz, torque, and horsepower
- Match an AC motor to an application and its load
- Identify NEMA enclosures and mounting configurations
- Describe Siemens NEMA, IEC, and above NEMA motors

This knowledge will help you better understand customer applications. In addition, you will be better able to describe products to customers and determine important differences between products. You should complete **Basics of Electricity** before attempting **Basics of AC Motors**. An understanding of many of the concepts covered in **Basics of Electricity** is required for this course.

After you have completed this course, if you wish to determine how well you have retained the information covered, you can complete a final exam online as described later in this course. If you pass the exam, you will be given the opportunity to print a certificate of completion.

Siemens is a trademark of Siemens AG. Product names mentioned may be trademarks or registered trademarks of their respective companies. Specifications subject to change without notice.

NEMA[®] is a registered trademark and service mark of the National Electrical Manufacturers Association, Rosslyn, VA 22209.

Underwriters Laboratories Inc.[®] and UL[®] are registered trademarks of Underwriters Laboratories Inc., Northbrook, IL 60062-2096.

Other trademarks are the property of their respective owners.

AC Motors

AC motors are used worldwide in many applications to transform electrical energy into mechanical energy. There are many types of AC motors, but this course focuses on **three-phase AC induction motors**, the most common type of motor used in industrial applications.

An AC motor of this type may be part of a pump or fan or connected to some other form of mechanical equipment such as a winder, conveyor, or mixer. Siemens manufactures a wide variety of AC motors. In addition to providing basic information about AC motors in general, this course also includes an overview of Siemens AC motors.

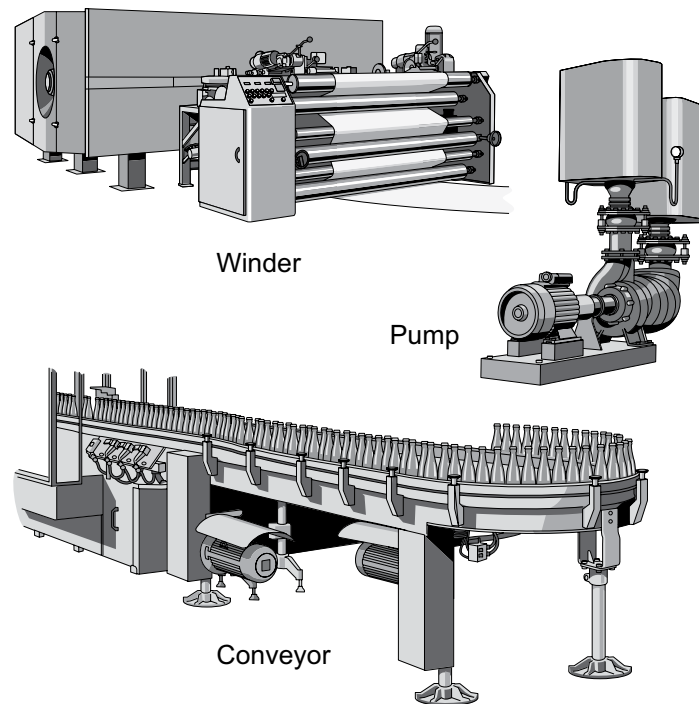

NEMA Motors

Throughout this course, reference is made to the **National Electrical Manufacturers Association (NEMA)**. NEMA develops standards for a wide range of electrical products, including AC motors. For example, NEMA Standard Publication MG 1 covers NEMA frame size AC motors, commonly referred to as NEMA motors.



Above NEMA Motors

In addition to manufacturing NEMA motors, Siemens also manufactures motors larger than the largest NEMA frame size. These motors are built to meet specific application requirements and are commonly referred to as **above NEMA motors**.

IEC Motors

Siemens also manufactures motors to **International Electrotechnical Commission (IEC)** standards. IEC is another organization responsible for electrical standards. IEC standards perform the same function as NEMA standards, but differ in many respects. In many countries, electrical equipment is commonly designed to comply with IEC standards. In the United States, although IEC motors are sometimes used, NEMA motors are more common. Keep in mind, however, that many U.S.-based companies build products for export to countries that follow IEC standards.

Force and Motion

Before discussing AC motors it is necessary to understand some of the basic terminology associated with motor operation. Many of these terms are familiar to us in some other context. Later in the course we will see how these terms apply to AC motors.

Force

In simple terms, a **force** is a push or a pull. Force may be caused by electromagnetism, gravity, or a combination of physical means.

Net Force

Net force is the vector sum of all forces that act on an object, including friction and gravity. When forces are applied in the same direction, they are added. For example, if two 10 pound forces are applied in the same direction the net force would be 20 pounds.

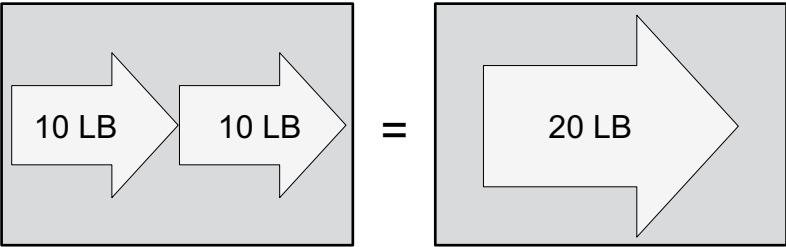

If 10 pounds of force is applied in one direction and 5 pounds of force is applied in the opposite direction, the net force would be 5 pounds and the object would move in the direction of the greater force.

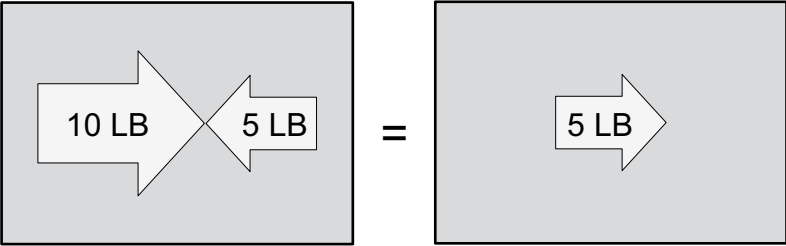

If 10 pounds of force is applied equally in both directions, the net force would be zero and the object would not move.

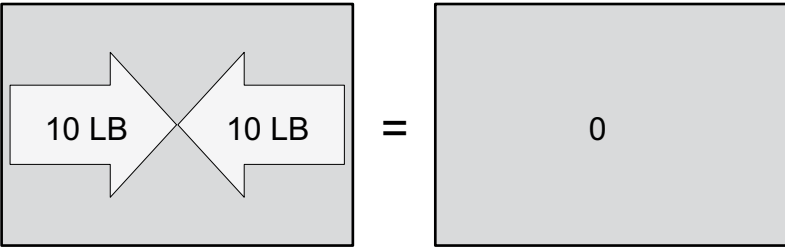

Torque

Torque is a twisting or turning force that causes an object to rotate. For example, a force applied to the end of a lever causes a turning effect or torque at the pivot point.

Torque (τ) is the product of force and radius (lever distance).

$$\tau = \text{Force} \times \text{Radius}$$

In the English system of measurements, torque is measured in pound-feet (lb-ft) or pound-inches (lb-in). For example, if 10 lbs of force is applied to a lever 1 foot long, the resulting torque is 10 lb-ft.

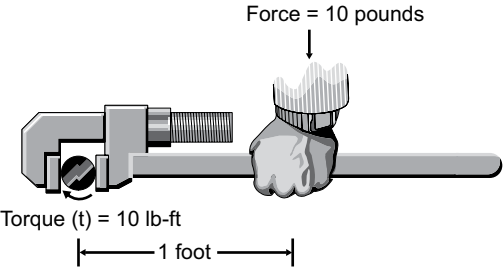

An increase in force or radius results in a corresponding increase in torque. Increasing the radius to two feet, for example, results in 20 lb-ft of torque.

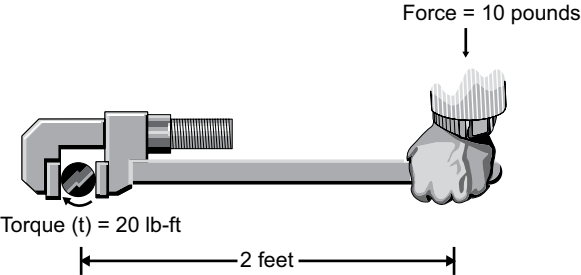

Speed

An object in motion takes time to travel any distance. **Speed** is the ratio of the distance traveled and the time it takes to travel the distance.

$$\text{Speed} = \frac{\text{Distance}}{\text{Time}}$$

Linear Speed

Linear speed is the rate at which an object travels a specified distance. Linear speed is expressed in units of distance divided by units of time, for example, miles per hour or meters per second (m/s). Therefore, if it take 2 seconds to travel 40 meters, the speed is 20 m/s.

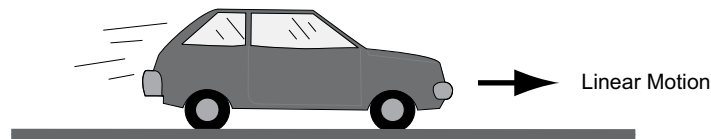

Angular (Rotational) Speed

The **angular speed** of a rotating object determines how long it takes for an object to rotate a specified angular distance. Angular speed is often expressed in revolutions per minute (RPM). For example, an object that makes ten complete revolutions in one minute, has a speed of 10 RPM.

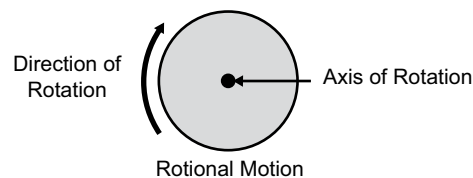

Acceleration

An object can change speed. An increase in speed is called **acceleration**. Acceleration occurs only when there is a change in the force acting upon the object. An object can also change from a higher to a lower speed. This is known as **deceleration** (negative acceleration). A rotating object, for example, can accelerate from 10 RPM to 20 RPM, or decelerate from 20 RPM to 10 RPM.

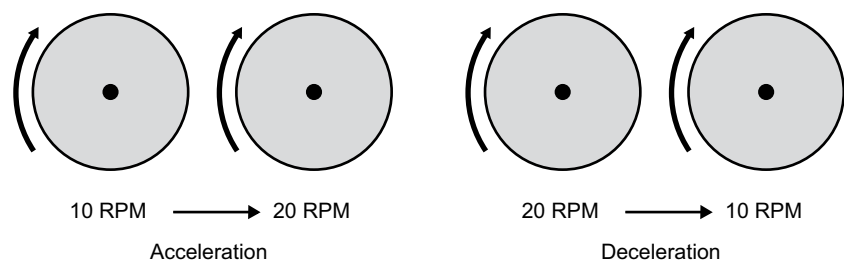

Inertia

Mechanical systems are subject to the **law of inertia**. The law of inertia states that an object will tend to remain in its current state of rest or motion unless acted upon by an external force. This property of resistance to acceleration/deceleration is referred to as the moment of inertia. The English system unit of measurement for inertia is pound-feet squared (lb-ft^2).

For example, consider a machine that unwinds a large roll of paper. If the roll is not moving, it takes a force to overcome inertia and start the roll in motion. Once moving, it takes a force in the reverse direction to bring the roll to a stop.

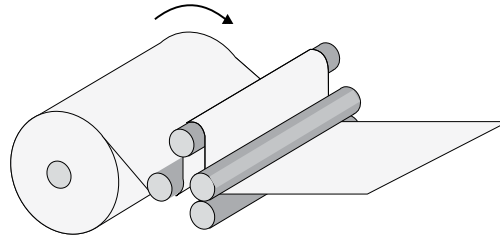

Any system in motion has losses that drain energy from the system. The law of inertia is still valid, however, because the system will remain in motion at constant speed if energy is added to the system to compensate for the losses.

Friction

Friction occurs when objects contact one another. As we all know, when we try to move one object across the surface of another object, friction increases the force we must apply. Friction is one of the most significant causes of energy loss in a machine.

Work

Whenever a force causes motion, **work** is accomplished. Work can be calculated simply by multiplying the force that causes the motion times the distance the force is applied.

$$\text{Work} = \text{Force} \times \text{Distance}$$

Since work is the product of force times the distance applied, work can be expressed in any compound unit of force times distance. For example, in physics, work is commonly expressed in joules. 1 joule is equal to 1 newton-meter, a force of 1 newton for a distance of 1 meter. In the English system of measurements, work is often expressed in foot-pounds (ft-lb), where 1 ft-lb equals 1 foot times 1 pound.

Power

Another often used quantity is **power**. Power is the rate of doing work or the amount of work done in a period of time.

$$\text{Power} = \frac{\text{Force} \times \text{Distance}}{\text{Time}}$$

$$\text{Power} = \frac{\text{Work}}{\text{Time}}$$

Horsepower

Power can be expressed in foot-pounds per second, but is often expressed in **horsepower**. This unit was defined in the 18th century by James Watt. Watt sold steam engines and was asked how many horses one steam engine would replace. He had horses walk around a wheel that would lift a weight. He found that a horse would average about 550 foot-pounds of work per second. Therefore, one horsepower is equal to 550 foot-pounds per second or 33,000 foot-pounds per minute.

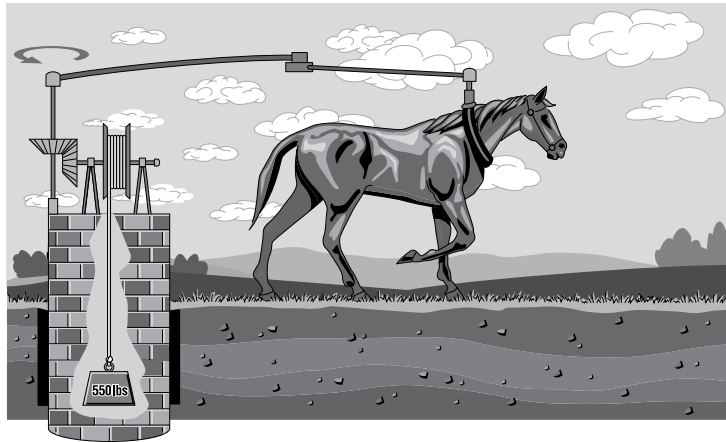

When applying the concept of horsepower to motors, it is useful to determine the amount of horsepower for a given amount of torque and speed. When torque is expressed in lb-ft and speed is expressed in RPM, the following formula can be used to calculate horsepower (HP). Note that an increase in torque, speed, or both increases horsepower.

$$\text{power in HP} = \frac{\text{Torque in lb-ft} \times \text{Speed in RPM}}{5252}$$

Horsepower and Kilowatts

AC motors manufactured in the United States are generally rated in horsepower, but motors manufactured in many other countries are generally rated in **kilowatts** (kW). Fortunately it is easy to convert between these units.

$$\text{power in kW} = 0.746 \times \text{power in HP}$$

For example, a a motor rated for 25 HP motor is equivalent to a motor rated for 18.65 kW.

$$0.746 \times 25 \text{ HP} = 18.65 \text{ kW}$$

Kilowatts can be converted to horsepower with the following formula.

$$\text{power in HP} = 1.34 \times \text{power in kW}$$

Review 1

1. If 20 pounds of force is applied in one direction and 5 pounds of force is applied in the opposite direction, the net force is ___ pounds.
2. _____ is a twisting or turning force.
3. If 40 pounds of force is applied at the end of a lever 2 feet long, the torque is ___ lb-ft.
4. The law of _____ states that an object will tend to remain in its current state of rest or motion unless acted upon by an external force.
5. _____ is equal to the distance traveled divided by the elapsed time.
6. The speed of a rotating object is often expressed in _____.
7. An increase in an object's speed is called _____.

AC Motor Construction

Three-phase AC induction motors are commonly used in industrial applications. This type of motor has three main parts, **rotor**, **stator**, and **enclosure**. The stator and rotor do the work, and the enclosure protects the stator and rotor.

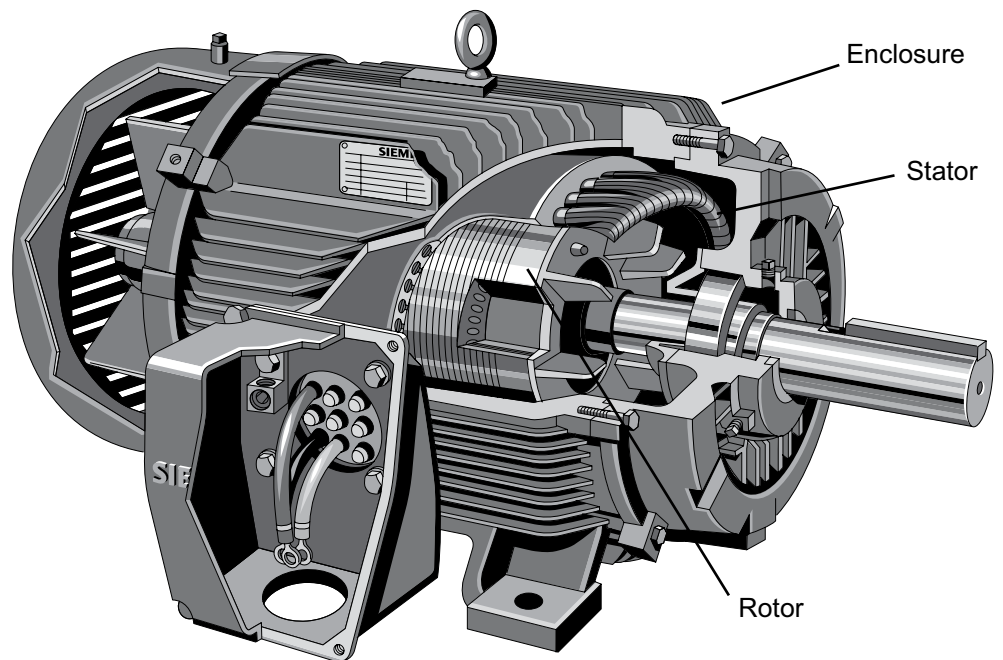

Stator Core

The stator is the stationary part of the motor's electromagnetic circuit. The stator core is made up of many thin metal sheets, called **laminations**. Laminations are used to reduce energy losses that would result if a solid core were used.

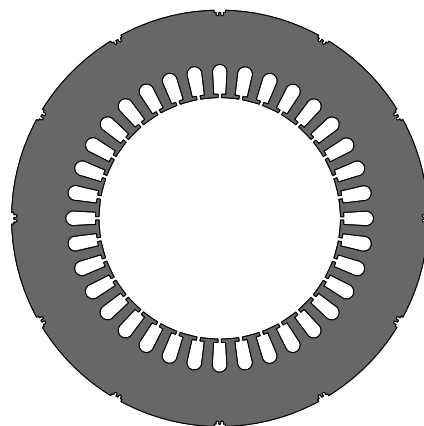

Stator Lamination

Stator Windings

Stator laminations are stacked together forming a hollow cylinder. Coils of insulated wire are inserted into slots of the stator core.

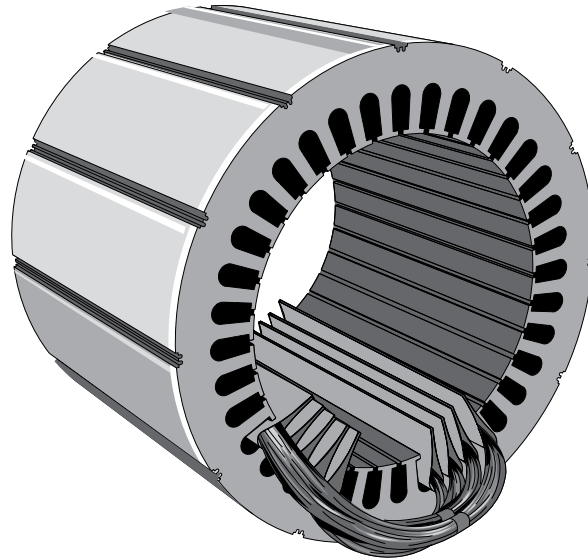

Stator Windings Partially Completed

When the assembled motor is in operation, the stator windings are connected directly to the power source. Each grouping of coils, together with the steel core it surrounds, becomes an electromagnet when current is applied. **Electromagnetism** is the basic principle behind motor operation.

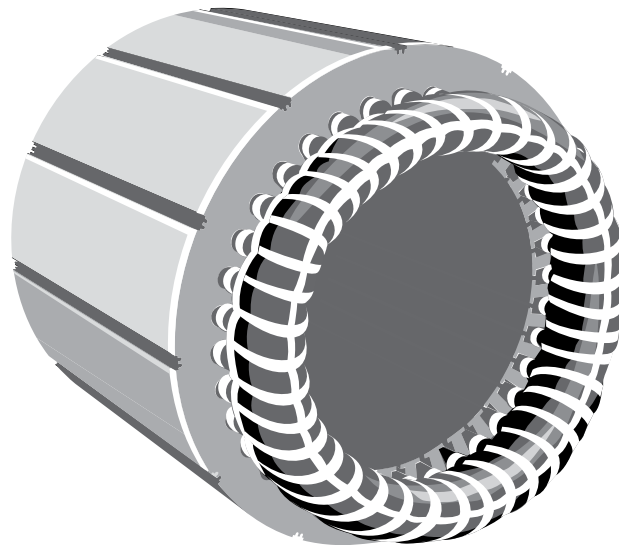

Stator Windings Completed

Rotor Construction

The rotor is the rotating part of the motor's electromagnetic circuit. The most common type of rotor used in a three-phase induction motor is a **squirrel cage rotor**. Other types of rotor construction is discussed later in the course. The squirrel cage rotor is so called because its construction is reminiscent of the rotating exercise wheels found in some pet cages.

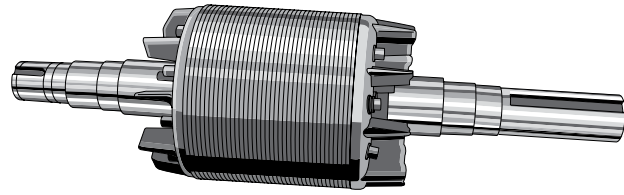

Rotor

A squirrel cage rotor core is made by stacking thin steel laminations to form a cylinder.

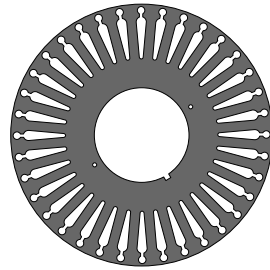

Rotor Lamination

Rather than using coils of wire as conductors, **conductor bars** are die cast into the slots evenly spaced around the cylinder. Most squirrel cage rotors are made by die casting aluminum to form the conductor bars. Siemens also makes motors with **die cast copper rotor conductors**. These motor exceed **NEMA Premium efficiency standards**.

After die casting, rotor conductor bars are mechanically and electrically connected with end rings. The rotor is then pressed onto a steel shaft to form a rotor assembly.

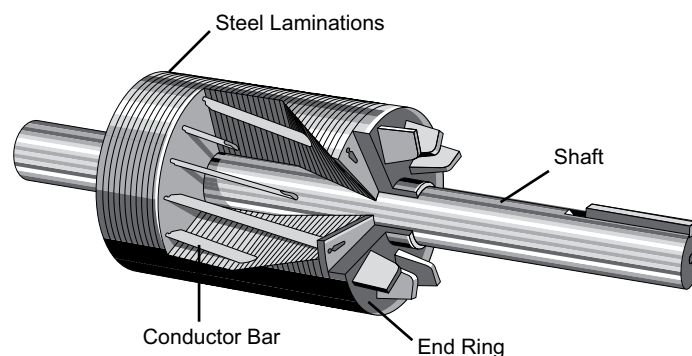

Cutaway View of Rotor

Enclosure

The enclosure consists of a **frame** (or yoke) and two end brackets (or bearing housings). The stator is mounted inside the frame. The rotor fits inside the stator with a slight air gap separating it from the stator. There is no direct physical connection between the rotor and the stator.

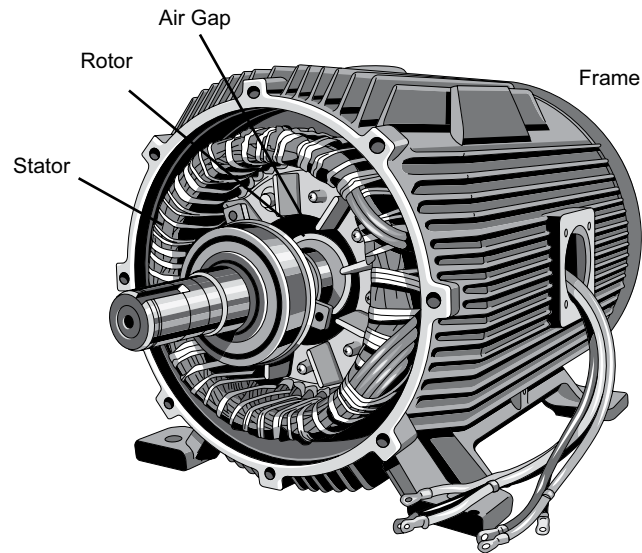

Partially Assembled Motor

The enclosure protects the internal parts of the motor from water and other environmental elements. The degree of protection depends upon the type of enclosure. Enclosure types are discussed later in this course.

Bearings, mounted on the shaft, support the rotor and allow it to turn. Some motors, like the one shown in the following illustration, use a **fan**, also mounted on the rotor shaft, to cool the motor when the shaft is rotating.

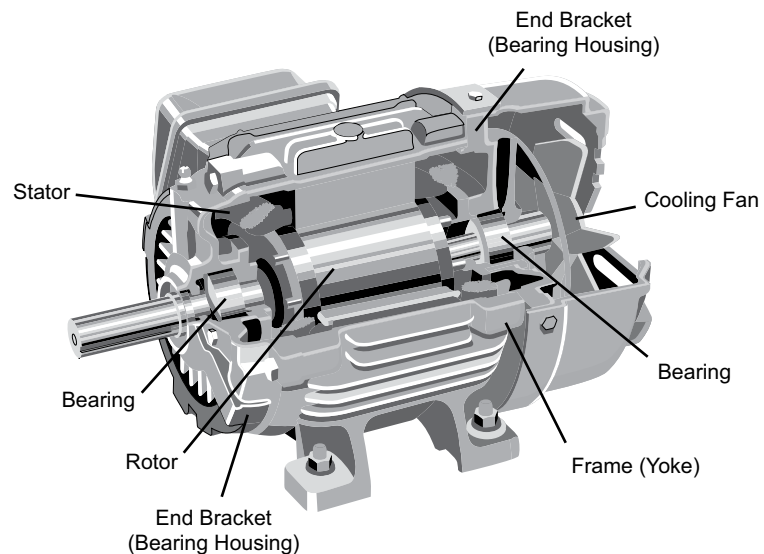

Cutaway View of Motor

Review 2

1. Identify the following components from the illustration:

A. _____

B. _____

C. _____

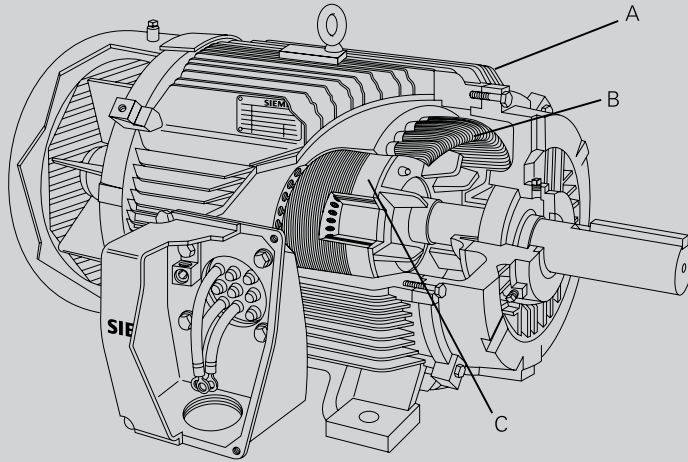

2. The _____ is the stationary part of an AC motor's electromagnetic circuit.

3. The _____ is the rotating electrical part of an AC motor.

4. The _____ rotor is the most common type of rotor used in three-phase AC motors.

5. The _____ protects the internal parts of the motor from water and other environmental elements.

Magnetism

The principles of **magnetism** play an important role in the operation of an AC motor. Therefore, in order to understand motors, you must understand magnets.

To begin with, all magnets have two characteristics. They attract iron and steel objects, and they interact with other magnets. This latter fact is illustrated by the way a compass needle aligns itself with the Earth's magnetic field.

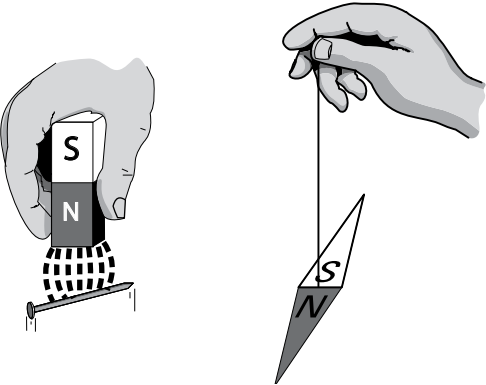

Magnetic Lines of Flux

The force that attracts an iron or steel object has continuous magnetic field lines, called **lines of flux**, that run through the magnet, exit the north pole, and return through the south pole. Although these lines of flux are invisible, the effects of magnetic fields can be made visible. For example, when a sheet of paper is placed on a magnet and iron filings are loosely scattered over the paper, the filings arrange themselves along the invisible lines of flux.

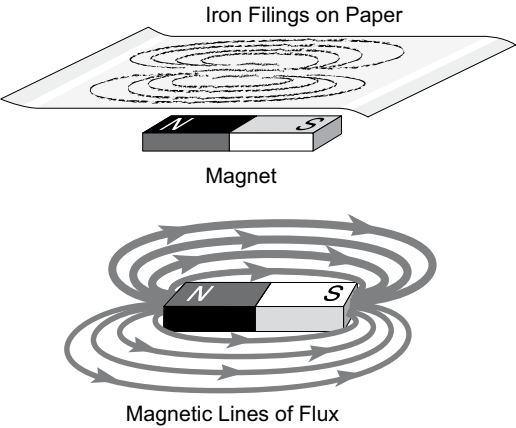

Unlike Poles Attract

The **polarities** of magnetic fields affect the interaction between magnets. For example, when the opposite poles of two magnets are brought within range of each other, the lines of flux combine and pull the magnets together.

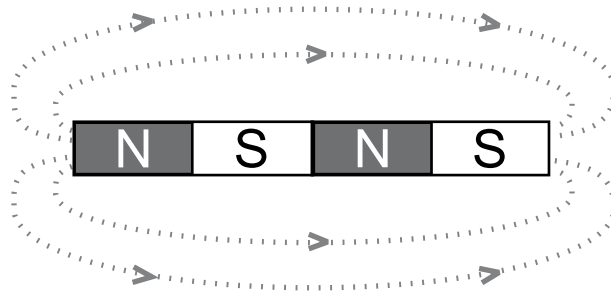

Like Poles Repel

However, when like poles of two magnets are brought within range of each other, their lines of flux push the magnets apart. In summary, **unlike poles attract** and **like poles repel**. The attracting and repelling action of the magnetic fields is essential to the operation of AC motors, but AC motors use **electromagnetism**.

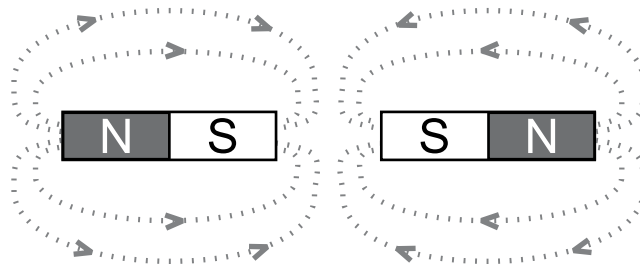

Electromagnetism

When current flows through a conductor, it produces a magnetic field around the conductor. The strength of the magnetic field is proportional to the amount of current.

Current produces a magnetic field

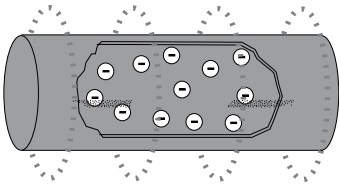

An increased current produces a stronger magnetic field

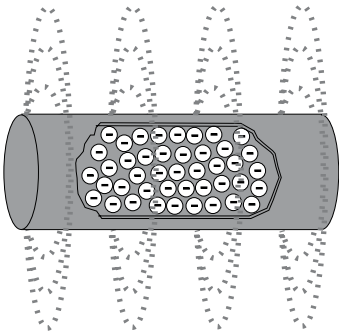

Left-Hand Rule for Conductors

The **left-hand rule for conductors** demonstrates the relationship between the flow of electrons and the direction of the magnetic field created by this current. If a current-carrying conductor is grasped with the left hand with the thumb pointing in the direction of electron flow, the fingers point in the direction of the magnetic lines of flux.

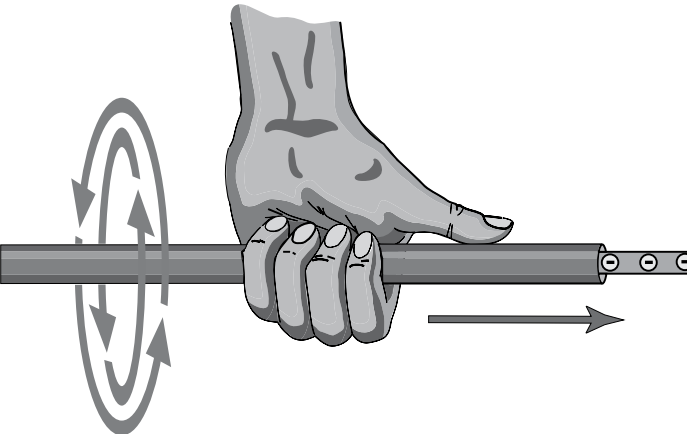

The following illustration shows that, when the electron flow is away from the viewer (as indicated by the plus sign), the lines of flux flow in a counterclockwise direction around the conductor. When the electron flow reverses and current flow is towards the viewer (as indicated by the dot), the lines of flux flow in a clockwise direction.



Electromagnet

An **electromagnet** can be made by winding a conductor into a coil and applying a DC voltage. The lines of flux, formed by current flow through the conductor, combine to produce a larger and stronger magnetic field. The center of the coil is known as the core. This simple electromagnet has an air core.

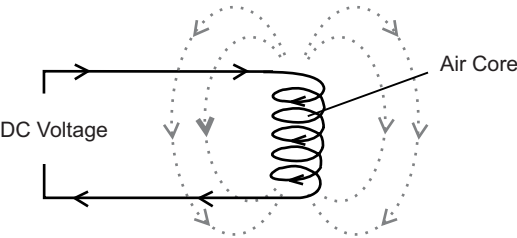

Adding an Iron Core

Iron conducts magnetic flux more easily than air. When an insulated conductor is wound around an **iron core**, a stronger magnetic field is produced for the same level of current.

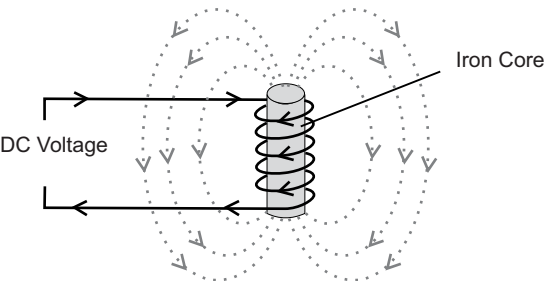

Number of Turns

The strength of the magnetic field created by the electromagnet can be increased further by increasing the number of **turns** in the coil. The greater the number of turns the stronger the magnetic field for the same level of current.

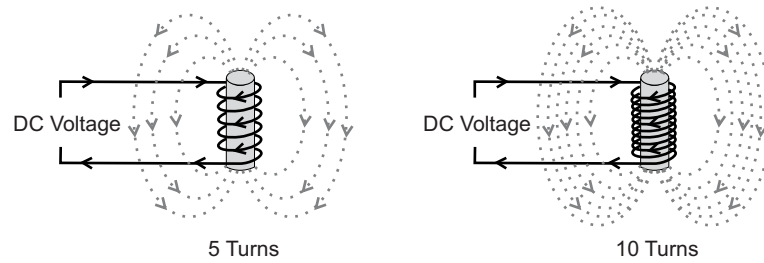

Changing Polarity

The magnetic field of an electromagnet has the same characteristics as a natural magnet, including a north and south pole. However, when the direction of current flow through the electromagnet changes, the polarity of the electromagnet changes.

The polarity of an electromagnet connected to an AC source changes at the **frequency** of the AC source. This is demonstrated in the following illustration.

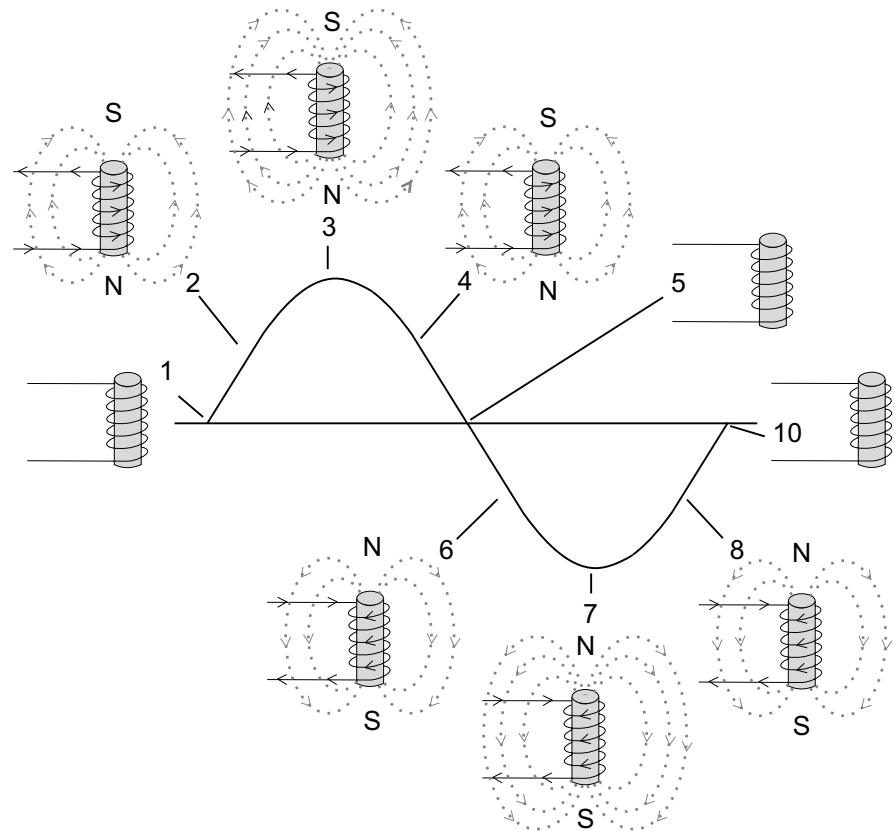

At time 1, there is no current flow, and no magnetic field is produced. At time 2, current is flowing in a positive direction, and a magnetic field builds up around the electromagnet. Note that the south pole is on the top and the north pole is on the bottom. At time 3, current flow is at its peak positive value, and the strength of the electromagnetic field has also peaked. At time 4, current flow decreases, and the magnetic field begins to collapse.

At time 5, no current is flowing and no magnetic field is produced. At time 6, current is increasing in the negative direction. Note that the polarity of the electromagnetic field has changed. The north pole is now on the top, and the south pole is on the bottom. The negative half of the cycle continues through times 7 and 8, returning to zero at time 9. For a 60 Hz AC power supply, this process repeats 60 times a second.

Induced Voltage

In the previous examples, the coil was directly connected to a power supply. However, a voltage can be **induced** across a conductor by merely moving it through a magnetic field. This same effect is caused when a stationary conductor encounters a changing magnetic field. This electrical principle is critical to the operation of AC induction motors.

In the following illustration, an electromagnet is connected to an AC power source. Another electromagnet is placed above it. The second electromagnet is in a separate circuit and there is no physical connection between the two circuits.

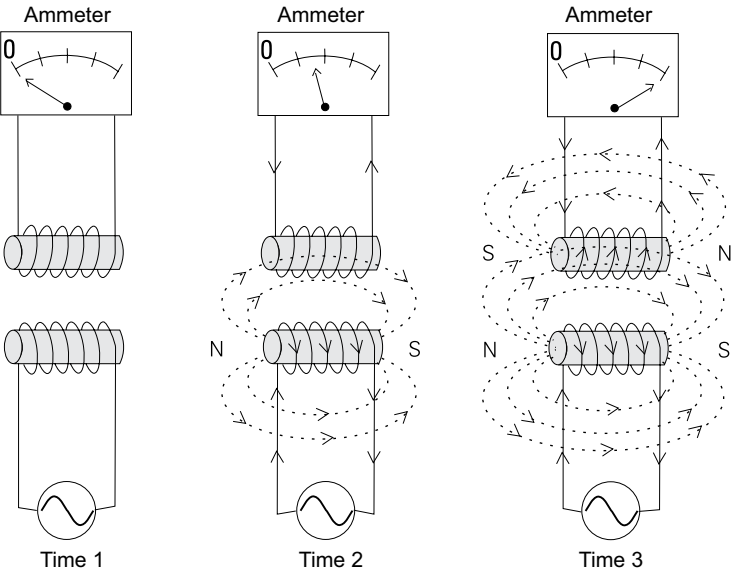

This illustration shows the build up of magnetic flux during the first quarter of the AC waveform. At time 1, voltage and current are zero in both circuits. At time 2, voltage and current are increasing in the bottom circuit. As magnetic field builds up in the bottom electromagnet, lines of flux from its magnetic field cut across the top electromagnet and induce a voltage across the electromagnet. This causes current to flow through the ammeter. At time 3, current flow has reached its peak in both circuits. As in the previous example, the magnetic field around each coil expands and collapses in each half cycle, and reverses polarity from one half cycle to another.

Electromagnetic Attraction

Note, however, that the polarity of the magnetic field induced in the top electromagnet is opposite the polarity of the magnetic field in the bottom electromagnet. Because opposite poles attract, the two electromagnets attract each other whenever flux has built up. If it were possible to move the bottom electromagnet, and the magnetic field was strong enough, the top electromagnet would be pulled along with it.

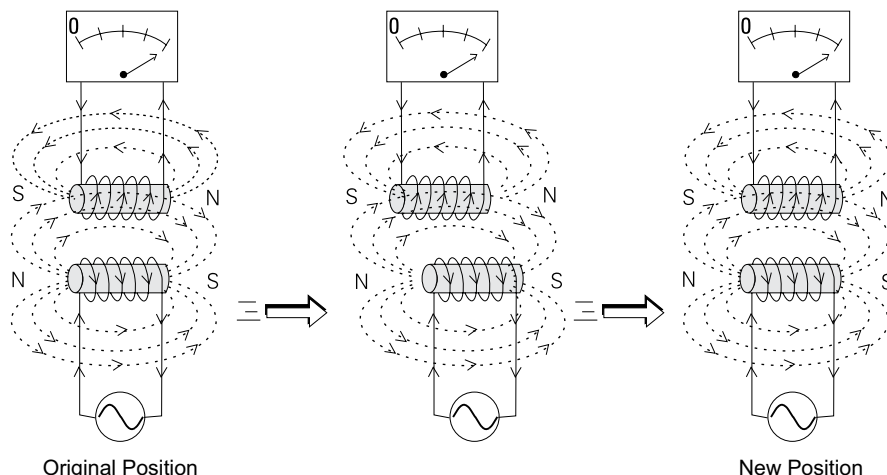

Review 3

- Magnetic lines of flux leave the _____ pole of a magnet and enter the _____ pole.
- In the following illustration, which magnets will attract each other and which magnets will repel each other?
 - | | |
|---|---|
| N | S |
|---|---|

N	S
---	---

 - | | |
|---|---|
| N | S |
|---|---|

S	N
---	---

 - | | |
|---|---|
| S | N |
|---|---|

N	S
---	---

 - | | |
|---|---|
| S | N |
|---|---|

S	N
---	---

- A _____ is produced around a conductor when current is flowing through it.
- Which of the following will increase the strength of the magnetic field for an electromagnet?
 - Increase the current flow
 - Increase the number of turns in the coil
 - Add an iron core to a coil
 - All the above

Developing a Rotating Magnetic Field

The principles of electromagnetism explain the shaft rotation of an AC motor. Recall that the stator of an AC motor is a hollow cylinder in which coils of insulated wire are inserted.

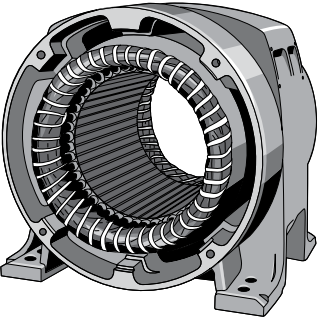

Stator Coil Arrangement

The following diagram shows the electrical configuration of stator windings. In this example, six windings are used, two for each of the three phases. The coils are wound around the soft iron core material of the stator. When current is applied, each winding becomes an electromagnet, with the two windings for each phase operating as the opposite ends of one magnet.

In other words, the coils for each phase are wound in such a way that, when current is flowing, one winding is a north pole and the other is a south pole. For example, when A1 is a north pole, A2 is a south pole and, when current reverses direction, the polarities of the windings also reverse.

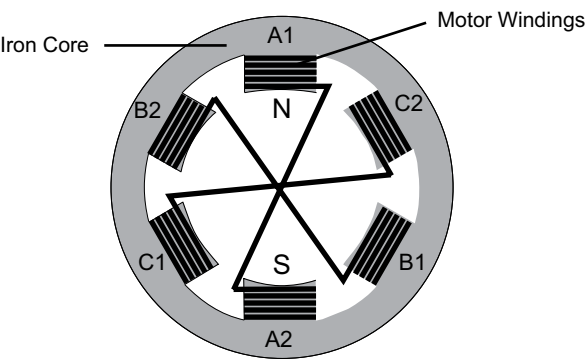

Stator Power Source

The stator is connected to a three-phase AC power source. The following illustration shows windings A1 and A2 connected to phase A of the power supply. When the connections are completed, B1 and B2 will be connected to phase B, and C1 and C2 will be connected to phase C.

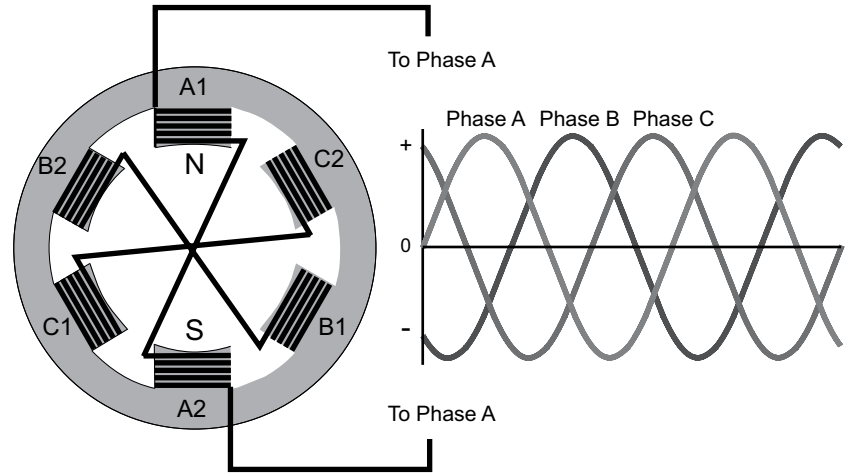

As the following illustration shows, coils A1, B1, and C1 are 120° apart. Note that windings A2, B2, and C2 also are 120° apart. This corresponds to the 120° separation between each electrical phase. Because each phase winding has two poles, this is called a **two-pole stator**.

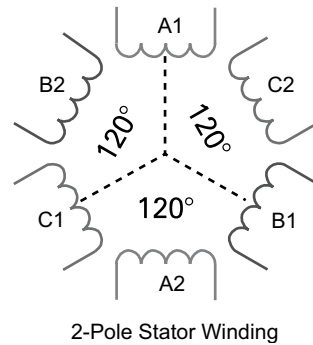

When AC voltage is applied to the stator, the magnetic field developed in a set of phase coils depends on the direction of current flow. Refer to the following chart as you read the explanation of how a rotating magnetic field is developed. This chart assumes that a positive current flow in the A1, B1 or C1 windings results in a north pole.

Winding	Current Flow Direction	
	Positive	Negative
A1	North	South
A2	South	North
B1	North	South
B2	South	North
C1	North	South
C2	South	North

Start

In the following illustration, a start time has been selected during which phase A has no current flow and its associated coils have no magnetic field. Phase B has current flow in the negative direction and phase C has current flow in the positive direction. Based on the previous chart, B1 and C2 are south poles and B2 and C1 are north poles. Magnetic lines of flux leave the B2 north pole and enter the nearest south pole, C2. Magnetic lines of flux also leave the C1 north pole and enter the nearest south pole, B1. The vector sum of the magnetic fields is indicated by the arrow.

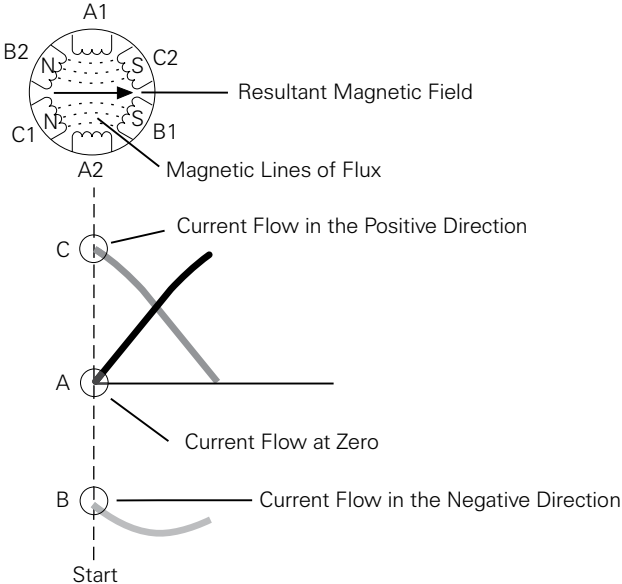

Time 1

The following chart shows the progress of the magnetic field vector as each phase has advanced 60°. Note that at time 1 phase C has no current flow and no magnetic field is developed in C1 and C2. Phase A has current flow in the positive direction and phase B has current flow in the negative direction.

As the previous chart shows, windings A1 and B2 are north poles and windings A2 and B1 are south poles. The resultant magnetic field vector has rotated 60° in the clockwise direction.

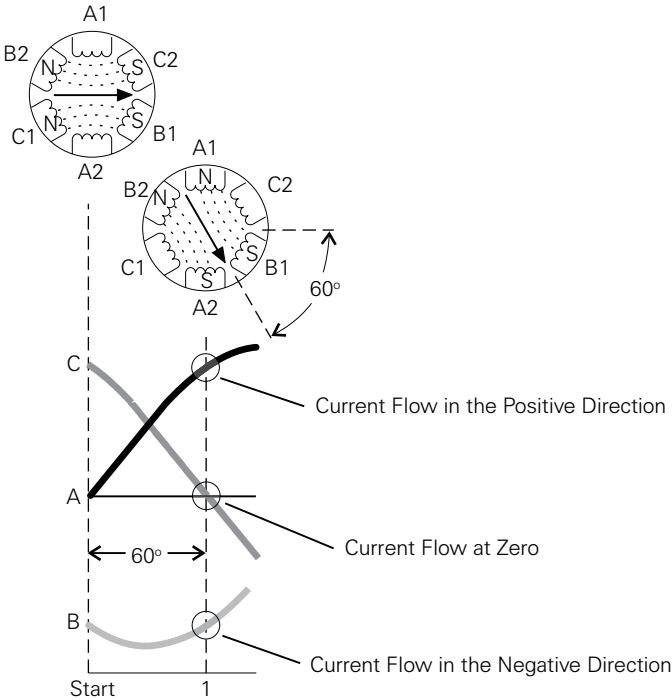

Time 2

At time 2, phase B has no current flow and windings B1 and B2 have no magnetic field. Current in phase A is flowing in the positive direction, but phase C current is now flowing in the negative direction. The resultant magnetic field vector has rotated another 60°.

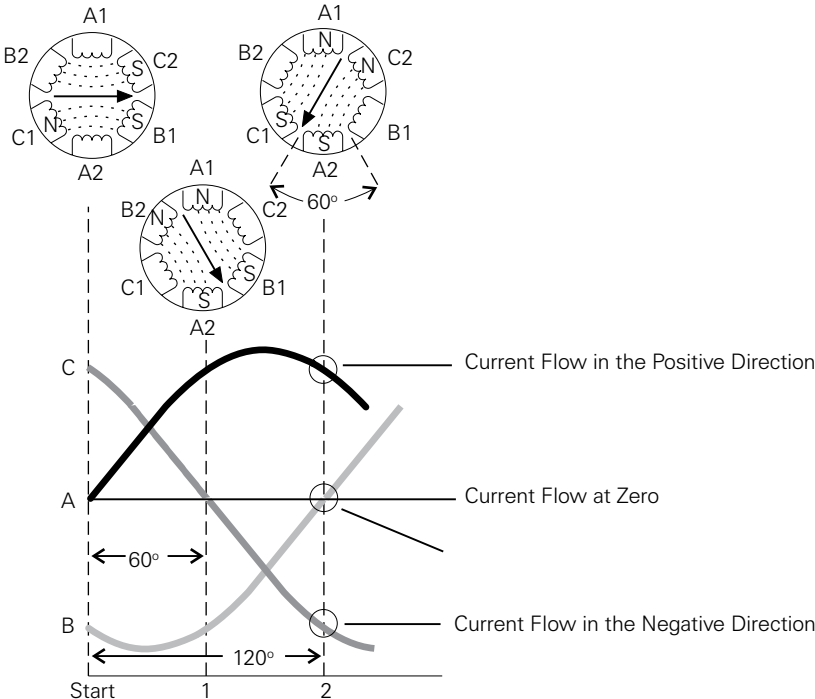

360° Rotation

At the end of six such time intervals, the magnetic field will have rotated one full revolution or 360°. This process repeats 60 times a second for a 60 Hz power source.

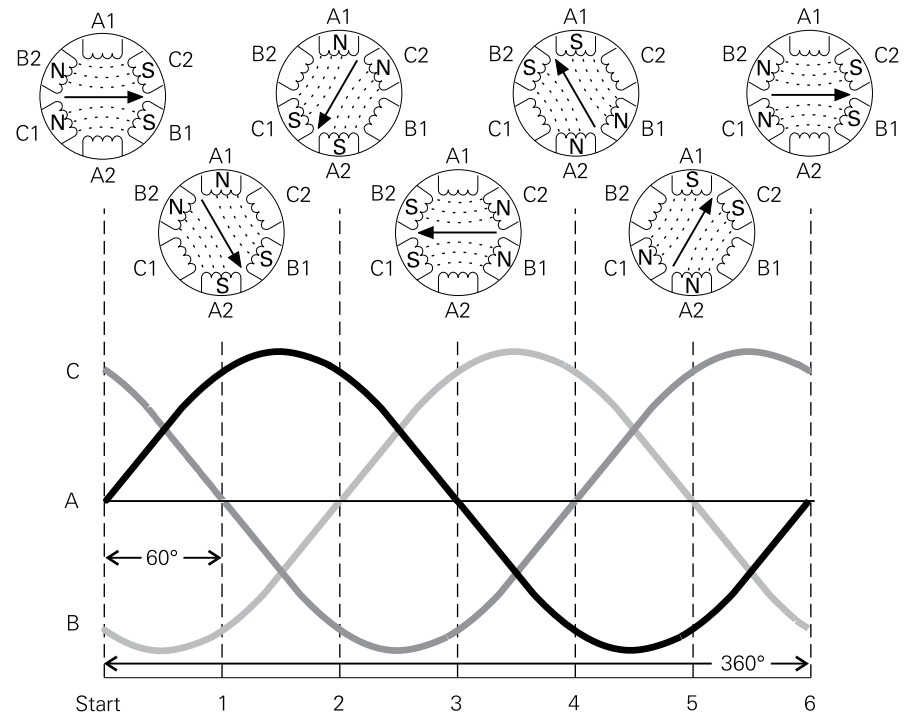

Synchronous Speed

The speed of the rotating magnetic field is referred to as the **synchronous speed (N_s)** of the motor. Synchronous speed is equal to 120 times the **frequency (F)**, divided by the **number of motor poles (P)**.

The synchronous speed for a two-pole motor operated at 60 Hz, for example, is 3600 RPM.

$$N_s = \frac{120F}{P} \implies N_s = \frac{120 \times 60}{2} \implies N_s = 3600 \text{ RPM}$$

Synchronous speed decreases as the number of poles increases. The following table shows the synchronous speed at 60 Hz for several different pole numbers.

No. of Poles	Synchronous Speed
2	3600
4	1800
6	1200
8	900
10	720

Rotor Rotation

Permanent Magnet

To see how a rotor works, a magnet mounted on a shaft can be substituted for the squirrel cage rotor. When the stator windings are energized, a rotating magnetic field is established. The magnet has its own magnetic field that interacts with the rotating magnetic field of the stator. The north pole of the rotating magnetic field attracts the south pole of the magnet, and the south pole of the rotating magnetic field attracts the north pole of the magnet. As the magnetic field rotates, it pulls the magnet along. AC motors that use a permanent magnet for a rotor are referred to as permanent magnet synchronous motors. The term **synchronous** means that the rotor's rotation is synchronized with the magnetic field, and the rotor's speed is the same as the motor's synchronous speed.

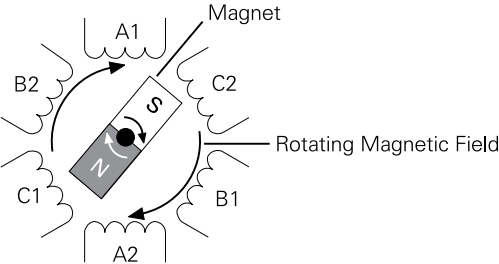

Induced Voltage Electromagnet

Instead of a permanent magnet rotor, a squirrel cage induction motor induces a current in its rotor, creating an electromagnet. As the following illustration shows, when current is flowing in a stator winding, the electromagnetic field created cuts across the nearest rotor bars.

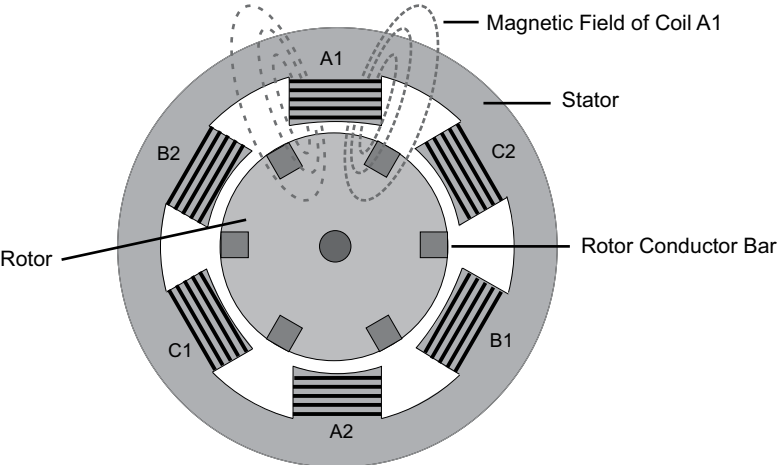

When a conductor, such as a rotor bar, passes through a magnetic field, a voltage (emf) is induced in the conductor. The induced voltage causes current flow in the conductor. In a squirrel cage rotor, current flows through the rotor bars and around the end ring and produces a magnetic field around each rotor bar.

Because the stator windings are connected to an AC source, the current induced in the rotor bars continuously changes and the squirrel cage rotor becomes an electromagnet with alternating north and south poles.

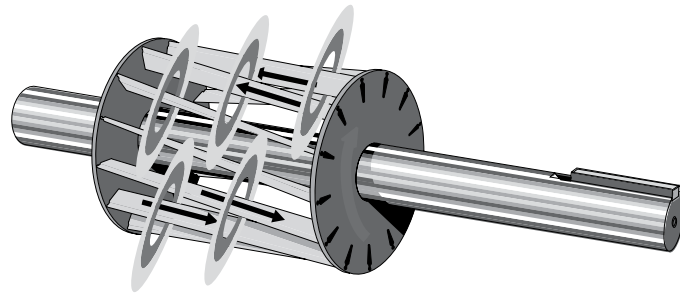

The following illustration shows an instant when winding A1 is a north pole and its field strength is increasing. The expanding field cuts across an adjacent rotor bar, inducing a voltage. The resultant current flow in one rotor bar produces a south pole. This causes the motor to rotate towards the A1 winding.

At any given point in time, the magnetic fields for the stator windings are exerting forces of attraction and repulsion against the various rotor bars. This causes the rotor to rotate, but not exactly at the motor's synchronous speed.

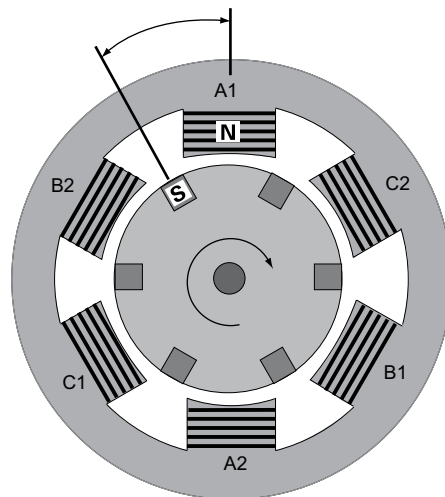

Slip

For a three-phase AC induction motor, the rotating magnetic field must rotate faster than the rotor to induce current in the rotor. When power is first applied to the motor with the rotor stopped, this difference in speed is at its maximum and a large amount of current is induced in the rotor.

After the motor has been running long enough to get up to operating speed, the difference between the synchronous speed of the rotating magnetic field and the rotor speed is much smaller. This speed difference is called **slip**. Slip is necessary to produce torque. Slip is also dependent on load. An increase in load causes the rotor to slow down, increasing slip. A decrease in load causes the rotor to speed up, decreasing slip. Slip is expressed as a percentage and can be calculated using the following formula.

$$\% \text{ Slip} = \frac{N_s - N_R}{N_s} \times 100$$

For example, a four-pole motor operated at 60 Hz has a **synchronous speed (Ns)** of 1800 RPM. If its **rotor speed (NR)** at full load is 1775 RPM, then its full load slip is 1.4%.

$$\% \text{ Slip} = \frac{1800 - 1775}{1800} \times 100$$

$$\% \text{ Slip} = 1.4\%$$

Wound Rotor Motor

The discussion to this point has been centered on the more common squirrel cage rotor. Another type of three-phase induction motor is the **wound rotor motor**. A major difference between the wound rotor motor and the squirrel cage rotor is that the conductors of the wound rotor consist of wound coils instead of bars. These coils are connected through slip rings and brushes to external variable resistors. The rotating magnetic field induces a voltage in the rotor windings. Increasing the resistance of the rotor windings causes less current to flow in the rotor windings, decreasing rotor speed. Decreasing the resistance causes more current to flow, increasing rotor speed.

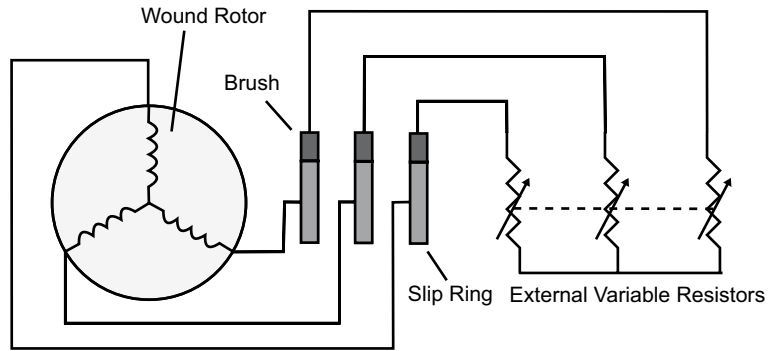

Synchronous Motor

Another type of three-phase AC motor is the **synchronous motor**. The synchronous motor is not an induction motor. One type of synchronous motor is constructed somewhat like a squirrel cage rotor. In addition to rotor bars, coil windings are also used. The coil windings are connected to an external DC power supply by slip rings and brushes.

When the motor is started, AC power is applied to the stator, and the synchronous motor starts like a squirrel cage rotor. DC power is applied to the rotor coils after the motor has accelerated. This produces a strong constant magnetic field in the rotor which locks the rotor in step with the rotating magnetic field. The rotor therefore turns at synchronous speed, which is why this is a synchronous motor.

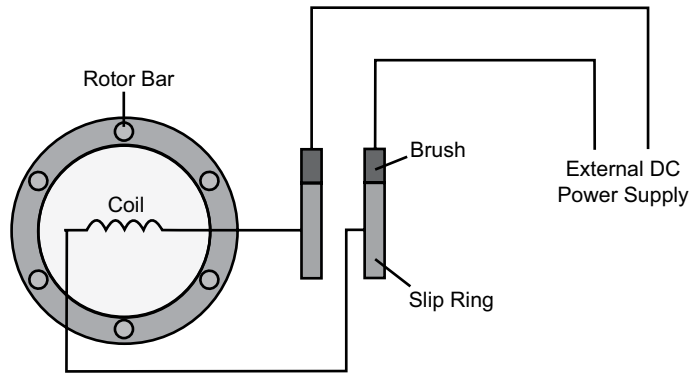

As previously mentioned, some synchronous motors use a permanent magnet rotor. This type of motor does not need a DC power source to magnetize the rotor.

Review 4

1. The following illustration applies to a _____ pole three-phase AC motor. When winding A1 is a south pole, winding A2 is a _____ pole.

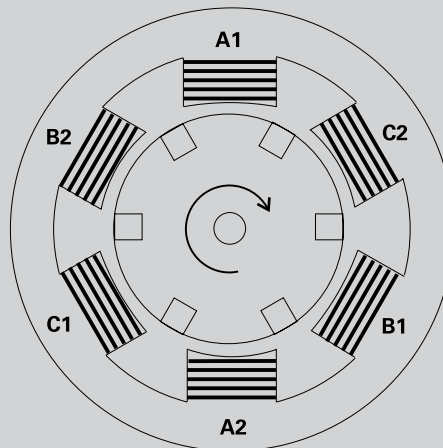





2. The speed of the rotating magnetic field is referred to as the motor's _____ speed.
3. The synchronous speed of a 60 Hz, four-pole motor is _____ RPM.
4. The difference in speed between synchronous speed and rotor speed is called _____.
5. A 2-pole motor is operating on a 60 Hz power supply. The rotor is turning at 3450 RPM. Slip is _____%.

Motor Specifications

Nameplate

The nameplate of a motor provides important information necessary for proper application. For example, The following illustration shows the nameplate of a 30 horsepower (H.P.) three-phase (3 PH) AC motor.

SIEMENS									
NEMA PREMIUM EFFICIENT									
ORD.NO.	1LE2321-2CB21-2AA3				E. No.				
TYPE	SD100			FRAME	286T				
H. P.	30.00			SERVICE FACTOR	1.15			3 PH	
AMPS	35.0			VOLTS	460				
R.P.M.	1775			HERTZ	60				
DUTY	CONT				40°C AMB.			DATE CODE	
CLASS INSUL	F	NEMA DESIGN	B	K.V.A. CODE	G	NEMA. NOM. EFF.	93.6		
SH. END BRG.	50BC03JPP3				OPP. END BRG.	50VC03JPP3			
 Made in Mexico by SIEMENS    									

The following paragraphs explain some of the other **nameplate** information for this motor.

Voltage Source (VOLTS) and Full-load Current (AMPS)

AC motors are designed to operate at standard voltages. This motor is designed to be powered by a three-phase 460 V supply. Its rated **full-load current** is 35.0 amps.

Base Speed (R.P.M.) and Frequency (HERTZ)

Base speed is the speed, given in RPM, at which the motor develops rated horsepower at rated voltage and frequency. Base speed is an indication of how fast the output shaft will turn the connected equipment when fully loaded. This motor has a base speed of 1775 RPM at a rated frequency of 60 Hz.

Because the synchronous speed of a 4-pole motor operated at 60 Hz is 1800 RPM, the full-load slip in this case is 1.4%. If the motor is operated at less than full load, the output speed will be slightly greater than the base speed.

$$\% \text{ Slip} = \frac{1800 - 1775}{1800} \times 100$$

$$\% \text{ Slip} = 1.4\%$$

Service Factor

Service factor is a number that is multiplied by the rated horsepower of the motor to determine the horsepower at which the motor can be operated. Therefore, a motor designed to operate at or below its nameplate horsepower rating has a service factor of 1.0.

Some motors are designed for a service factor higher than 1.0, so that they can, at times, exceed their rated horsepower. For example, this motor has a service factor of 1.15. A 1.15 service factor motor can be operated 15% higher than its nameplate horsepower. Therefore this 30 HP motor can be operated at 34.5 HP. Keep in mind that any motor operating continuously above its rated horsepower will have a reduced service life.

Insulation Class

NEMA defines **motor insulation classes** to describe the ability of motor insulation to handle heat. The four insulation classes are A, B, F, and H. All four classes identify the allowable temperature rise from an ambient temperature of 40° C (104° F). Classes B and F are the most commonly used.

Ambient temperature is the temperature of the surrounding air. This is also the temperature of the motor windings before starting the motor, assuming the motor has been stopped long enough. Temperature rises in the motor windings as soon as the motor is started. The combination of ambient temperature and allowed temperature rise equals the maximum rated winding temperature. If the motor is operated at a higher winding temperature, service life will be reduced. A 10° C increase in the operating temperature above the allowed maximum can cut the motor's insulation life expectancy in half.

The following illustration shows the **allowable temperature rise** for motors operated at a 1.0 service factor at altitudes no higher than 3300 ft. Each insulation class has a margin allowed to compensate for the motor's hot spot, a point at the center of the motor's windings where the temperature is higher. For motors with a service factor of 1.15, add 10° C to the allowed temperature rise for each motor insulation class.

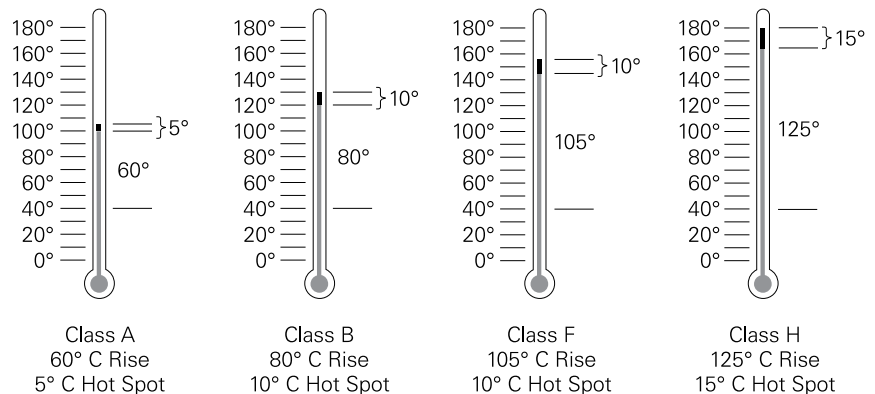

The motor in this example has insulation class F and a service factor of 1.15. This means that its winding temperature is allowed to rise to 155° C with an additional 10° C hot spot allowance.

NEMA Motor Design

NEMA also uses letters (A, B, C, and D) to identify **motor designs** based on torque characteristics. The motor in this example is a design B motor, the most common type. Motor design A is the least common type. The characteristics of motor designs B, C and D are discussed in the next section of this course.

Motor Efficiency

Motor efficiency is a subject of increasing importance, especially for AC motors. AC motor efficiency is important because AC motors are widely used and account for a significant percentage of the energy used in industrial facilities.

Motor efficiency is the percentage of the energy supplied to the motor that is converted into mechanical energy at the motor's shaft when the motor is continuously operating at full load with the rated voltage applied. Because motor efficiencies can vary among motors of the same design, the **NEMA nominal efficiency** percentage on the nameplate is representative of the average efficiency for a large number of motors of the same type. The motor in this example has a NEMA nominal efficiency of 93.6%.

Both NEMA and the **Energy Policy Act of 1992 (EPAct)** specify the same process for testing motor efficiency. In 2001, NEMA established the **NEMA Premium** designation for three-phase AC motors that meet even higher efficiency standards than required by EPAct. More recently, the **Energy Independence and Security Act of 2007 (EISA)** was passed. EISA requires most motors manufactured after December 19, 2010 to meet NEMA Premium efficiency levels. This includes motors previously covered by EPAct and some additional categories of motors.

Siemens NEMA Premium Efficient motors meet NEMA Premium efficiency standards and **Siemens Ultra Efficient motors** with our exclusive **die cast copper rotor technology** exceed NEMA Premium efficiency standards.

NEMA Motor Characteristics

Standard Motor Designs

Motors are designed with speed-torque characteristics to match the requirements of common applications. The four standard NEMA motor designs, A, B, C, and D, have different characteristics. This section provides descriptions for each of these motor designs with emphasis on NEMA design B, the most common three-phase AC induction motor design.

Speed-Torque Curve for NEMA B Motor

Because motor torque varies with speed, the relationship between speed and torque is often shown in a graph, called a speed-torque curve. This curve shows the motor's torque, as a percentage of full-load torque, over the motor's full speed range, shown as a percentage of its synchronous speed.

The following speed-torque curve is for a **NEMA B motor**. NEMA B motors are general purpose, single speed motors suited for applications that require normal starting and running torque, such as fans, pumps, lightly-loaded conveyors, and machine tools.

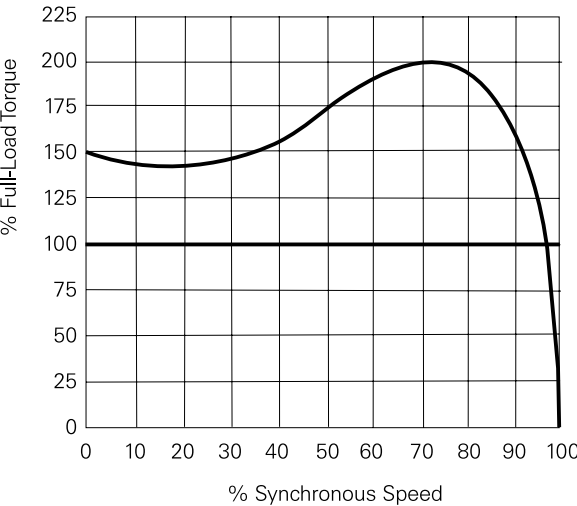

Using a 30 HP, 1765 RPM NEMA B motor as an example, full-load torque can be calculated by transposing the formula for horsepower.

$$\text{HP} = \frac{\text{Torque (in lb-ft)} \times \text{Speed (in RPM)}}{5252}$$

$$\text{Torque (in lb-ft)} = \frac{\text{HP} \times 5252}{\text{Speed (in RPM)}} = \frac{30 \times 5252}{1765} = 89.3 \text{ lb-ft}$$

Starting Torque

Starting torque, also referred to as **locked rotor torque**, is the torque that the motor develops each time it is started at rated voltage and frequency. When voltage is initially applied to the motor's stator, there is an instant before the rotor turns. At this instant, a NEMA B motor develops a torque approximately equal to 150% of full-load torque. For the 30 HP, 1765 RPM motor used in this example, that's equal to 134.0 lb-ft of torque.

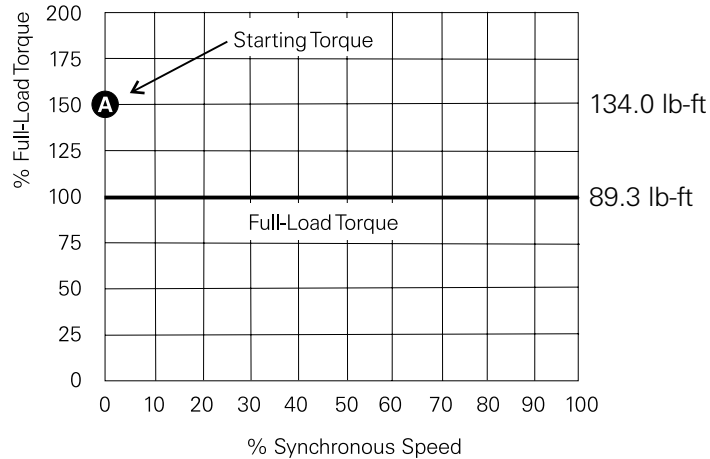

Pull-up Torque

As the motor picks up speed, torque decreases slightly until point B on the graph is reached. The torque available at this point is called **pull-up torque**. For a NEMA B motor, this is slightly lower than starting torque, but greater than full-load torque.

Breakdown Torque

As speed continues to increase from point B to point C, torque increases up to a maximum value at approximately 200% of full-load torque. This maximum value of torque is referred to as **breakdown torque**. The 30 HP motor in this example has a breakdown torque of approximately 178.6 lb-ft.

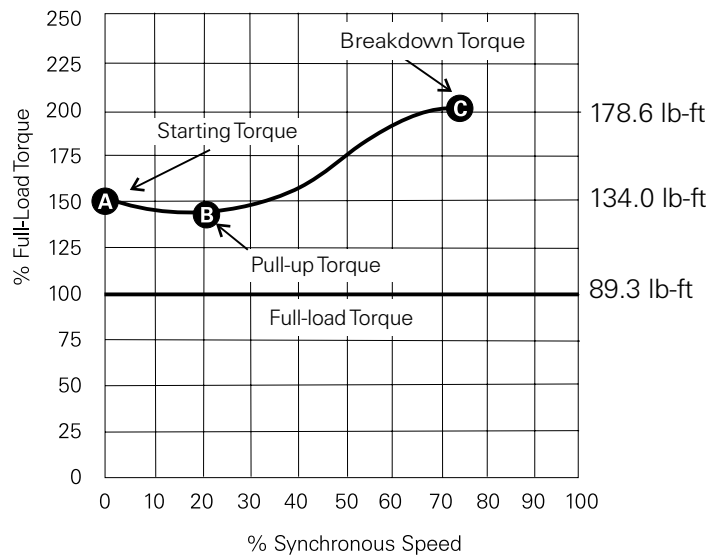

Full-Load Torque

Torque decreases rapidly as speed increases beyond breakdown torque until it reaches **full-load torque** at a speed slightly less than 100% of synchronous speed. Full-load torque is developed with the motor operating at rated voltage, frequency, and load. The motor in this example has a synchronous speed of 1800 RPM and a full-load speed of 1765 RPM. Therefore, its slip is 1.9%.

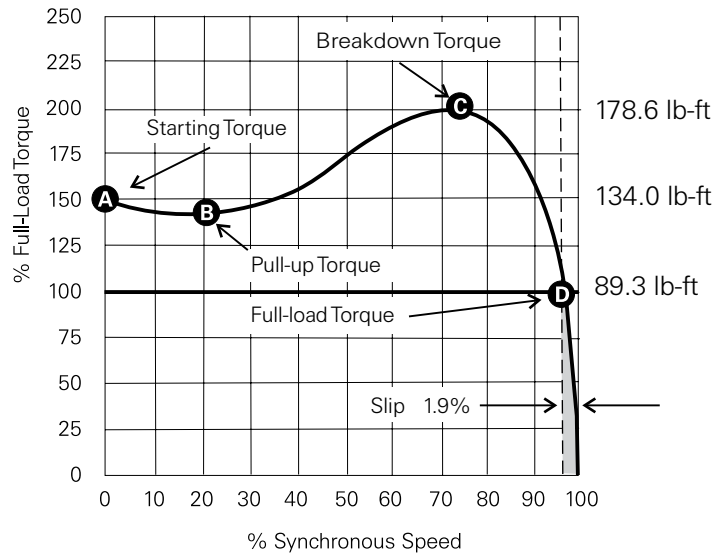

Speed-torque curves are useful for understanding motor performance under load. The following speed-torque curve shows four load examples. This motor is appropriately sized for constant torque load 1 and variable torque load 1. In each case, the motor will accelerate to its rated speed. With constant torque load 2, the motor does not have sufficient starting torque to turn the rotor. With variable torque load 2, the motor cannot reach rated speed. In these last two examples, the motor will most likely overheat until its overload relay trips.

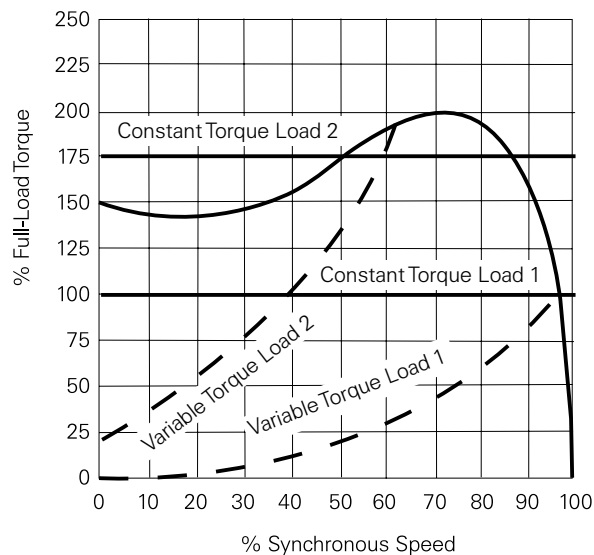

Starting Current and Full-Load Current

Starting current, also referred to as **locked rotor current**, is the current supplied to the motor when the rated voltage is initially applied with the rotor at rest. **Full-load current** is the current supplied to the motor with the rated voltage, frequency, and load applied and the rotor up to speed. For a NEMA B motor, starting current is typically 600-650% of full-load current. Knowledge of the current requirements for a motor is critical for the proper application of overcurrent protection devices.

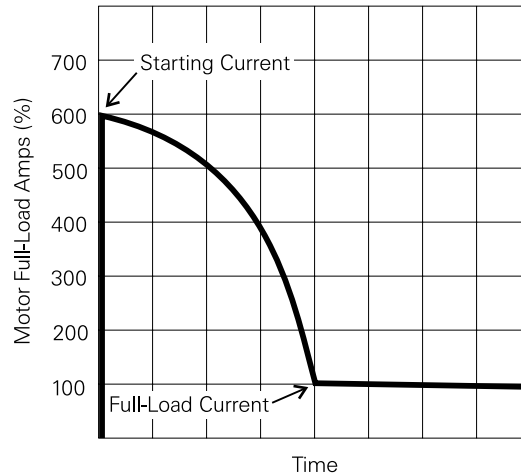

NEMA A Motor

NEMA A motors are the least common design. NEMA A motors have a speed-torque curve similar to that of a NEMA B motor, but typically have higher starting current. As a result, overcurrent protection devices must be sized to handle the increased current. NEMA A motors are typically used in the same types of applications as NEMA B motors.

NEMA C Motor

NEMA C motors are designed for applications that require a high starting torque for hard to start loads, such as heavily-loaded conveyors, crushers and mixers. Despite the high starting torque, these motors have relatively low starting current. Slip and full-load torque are about the same as for a NEMA B motor. NEMA C motors are typically single speed motors which range in size from approximately 5 to 200 HP.

The following speed-torque curve is for a 30 HP NEMA C motor with a full-load speed of 1765 RPM and a full-load torque of 89.3 lb-ft. In this example, the motor has a starting torque of 214.3 lb-ft, 240% of full-load torque and a breakdown torque of 174 lb-ft.

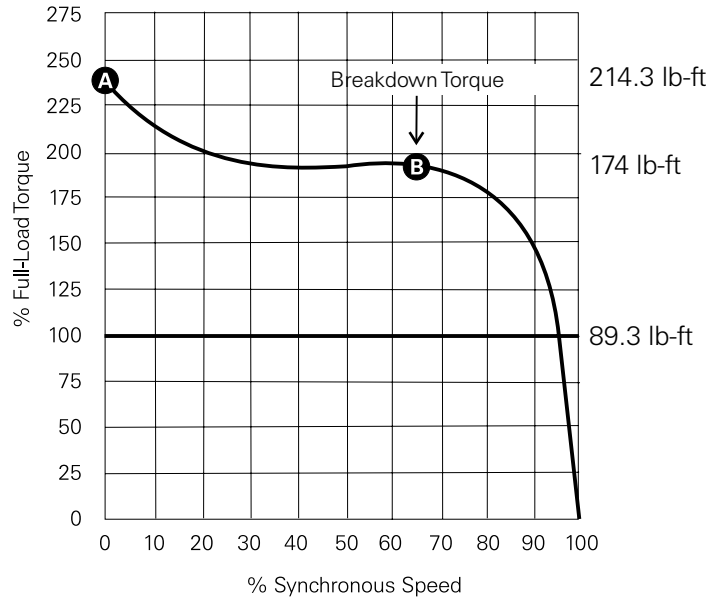

NEMA D Motor

The starting torque of a **NEMA design D motor** is approximately 280% of the motor's full-load torque. This makes it appropriate for very hard to start applications such as punch presses and oil well pumps. NEMA D motors have no true breakdown torque. After starting, torque decreases until full-load torque is reached. Slip for NEMA D motors ranges from 5 to 13%.

The following speed torque curve is for a 30 HP NEMA D motor with a full-load speed of 1656 RPM and a full load torque of 95.1 lb-ft. This motor develops approximately 266.3 lb-ft of starting torque.

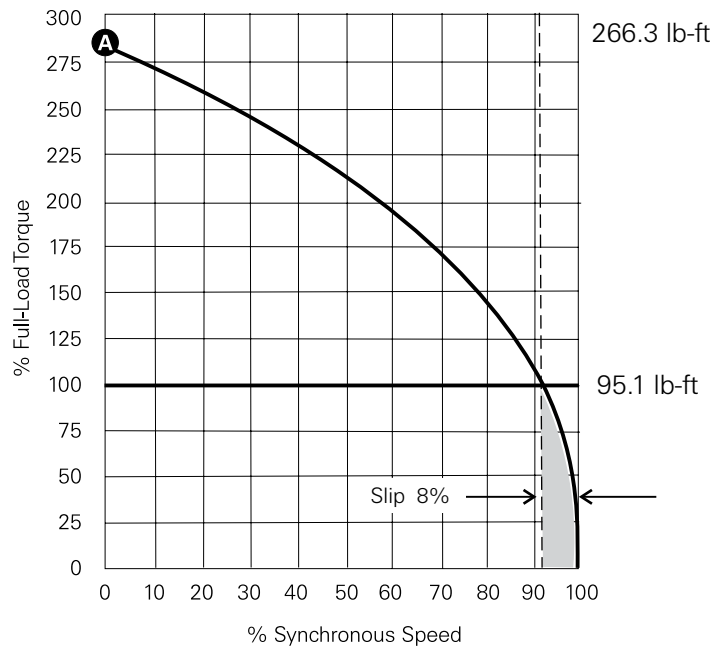

Review 5

1. A 30 HP motor with a 1.15 service factor can be operated at _____ HP.
2. A motor with Class F insulation and a 1.0 service factor has a maximum temperature rise of _____ °C plus a _____ °C hot spot allowance.
3. The starting torque of a NEMA B motor is approximately _____ % of full-load torque.
4. The maximum torque value on a NEMA B motor speed-torque curve is called _____ torque.

Derating Factors

Several factors can affect the performance of an AC motor. These must be considered when applying a motor.

Voltage Variation

As previously discussed, AC motors have a rated voltage and frequency. Some motors have connections for more than one rated voltage. The following table shows the most common voltage ratings for NEMA motors.

Standardized Voltages/Frequencies	
60 Hz	50 Hz
115 VAC	380 VAC
220 VAC	400 VAC
230 VAC	415 VAC
460 VAC	220/380 VAC
575 VAC	

A small variation in supply voltage can have a dramatic effect on motor performance. In the following chart, for example, when voltage is 10% below the rated voltage of the motor, the motor has 20% less starting torque. This reduced voltage may prevent the motor from getting its load started or keeping it running at rated speed.

A 10% increase in supply voltage, on the other hand, increases the starting torque by 20%. This increased torque may cause damage during startup. A conveyor, for example, may lurch forward at startup. A voltage variation also causes similar changes in the motor's starting and full-load currents and temperature rise.

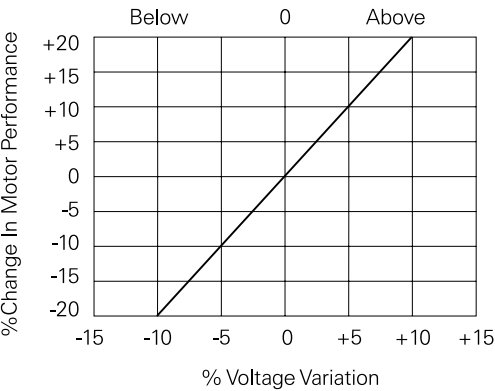

Frequency

A variation in the frequency at which the motor operates causes changes primarily in speed and torque characteristics. A 5% increase in frequency, for example, causes a 5% increase in full-load speed and a 10% decrease in torque.

Frequency Variation	% Change Full-Load Speed	% Change Starting Torque
+5%	+5%	-10%
-5%	-5%	+11%

Altitude

Standard motors are designed to operate below 3300 feet. Air is thinner, and heat is not dissipated as quickly above 3300 feet. Most motors must be **derated** for altitudes above 3300 feet. The following chart shows typical horsepower derating factors, but the derating factor should be checked for each motor. A 50 HP motor operated at 6000 feet, for example, would be derated to 47 HP, providing the 40°C ambient rating is still required.

Altitude	Derating Factor
3300 - 5000	0.97
5001 - 6600	0.94
6601 - 8300	0.90
8301 - 9900	0.86
9901 - 11,500	0.82

$$50 \text{ HP} \times 0.94 = 47 \text{ HP}$$

Ambient Temperature

The ambient temperature may also have to be considered. The ambient temperature requirement may be reduced from 40°C to 30°C at 6600 feet on many motors. However, a motor with a higher insulation class may not require derating in these conditions.

Ambient Temperature (°C)	Maximum Altitude (Feet)
40	3300
30	6600
20	9900

AC Motors and AC Drives

Many applications require the speed of an AC motor to vary. The easiest way to vary the speed of an AC induction motor is to use an AC drive to vary the applied frequency. Operating a motor at other than the rated frequency and voltage affect both motor current and torque.

Volts per Hertz (V/Hz)

The **volts per hertz (V/Hz) ratio** is the ratio of applied voltage to applied frequency for a motor. 460 VAC is the most common voltage rating for an industrial AC motor manufactured for use in the United States. These motors have a frequency rating of 60Hz. This provides a V/Hz ratio of 7.67. Not every motor has a 7.67 V/Hz ratio. A 230 Volt, 60 Hz motor, for example, has a 3.8 V/Hz ratio.

$$\frac{460 \text{ V}}{60 \text{ Hz}} = 7.67 \text{ V/Hz} \quad \frac{230 \text{ V}}{60 \text{ Hz}} = 3.8 \text{ V/Hz}$$

Constant Torque Operation

AC motors running on an AC line operate with a constant flux because voltage and frequency are constant. Motors operated with constant flux are said to have constant torque. Actual torque produced, however, is dependent upon the load.

An AC drive is capable of operating a motor with constant flux from approximately 0 Hz to the motor's rated nameplate frequency (typically 60 Hz). This is the **constant torque range**. As long as a constant volts per hertz ratio is maintained the motor will have constant torque characteristics.

The following graphs illustrate the constant volts per hertz ratio of a 460 volt, 60 Hz motor and a 230 volt, 60 Hz motor operated over the constant torque range. Keep in mind that if the applied frequency increases, stator reactance increases. In order to compensate for this, the drive must simultaneously increase voltage proportionally. Otherwise, stator current, flux, and torque would decrease.

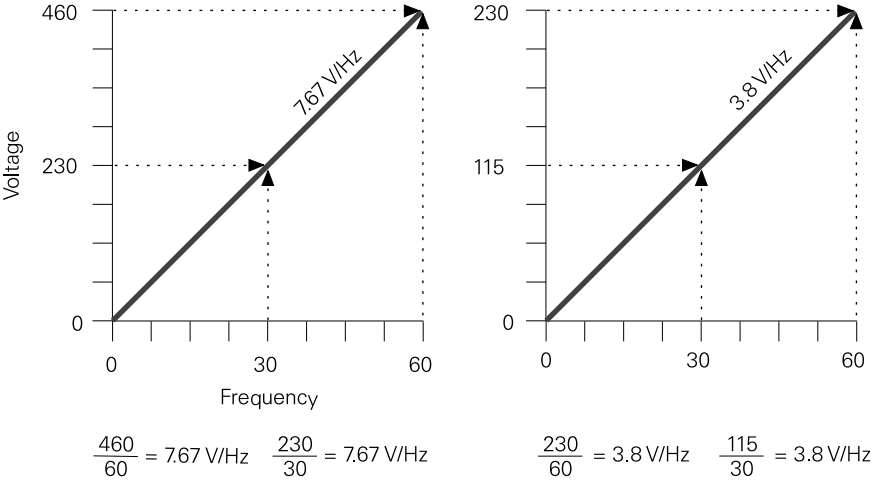

Constant Horsepower

Some applications require the motor to be operated above base speed. Because applied voltage must not exceed the rated nameplate voltage, torque decreases as speed increases. This is referred to as the **constant horsepower range** because any change in torque is compensated by the opposite change in speed.

$$\text{power in HP} = \frac{\text{Torque in lb-ft} \times \text{Speed in RPM}}{5252}$$

If the motor is operated in both the constant torque and constant horsepower ranges, constant volts per hertz and torque are maintained up to 60 Hz. Above 60 Hz, the volts per hertz ratio decreases, with a corresponding decrease in torque.

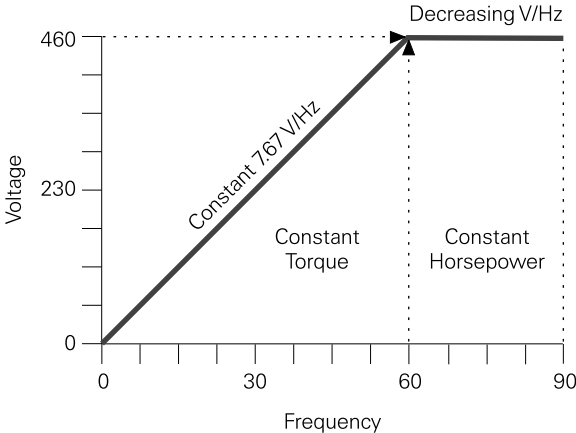

Reduced Voltage and Frequency Starting

Recall that when a NEMA B motor is started at full voltage, it develops approximately 150% starting torque and 600% starting current. When the motor is controlled by an AC drive, the motor is started at reduced voltage and frequency. For example, the motor may start with approximately 150% torque, but only 150% of full load current.

As the motor is brought up to speed, voltage and frequency are increased, and this has the effect of shifting the motor's speed-torque curve to the right. The dotted lines on the following speed-torque curve represent the portion of the curve not used by the drive. The drive starts and accelerates the motor smoothly as frequency and voltage are gradually increased to the desired speed.

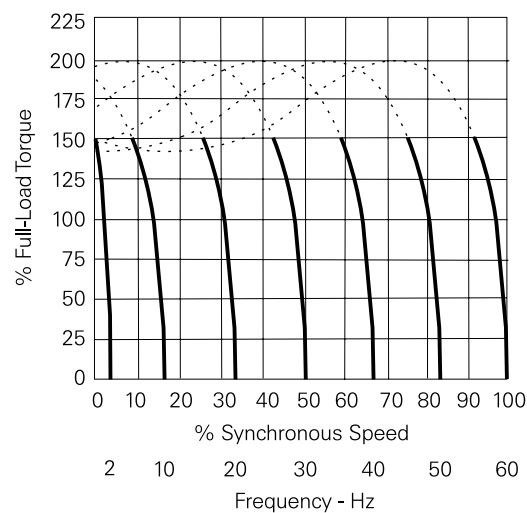

Some applications require higher than 150% starting torque. A conveyor, for example, may require 200% rated torque for starting. This is possible if the drive and motor are appropriately sized.

Selecting a Motor

AC drives often have more capability than the motor. Drives can run at higher frequencies than may be suitable for an application. In addition, drives can run at speeds too low for self-cooled motors to develop sufficient air flow. Each motor must be evaluated according to its own capability before selecting it for use on an AC drive.

Harmonics, voltage spikes, and voltage rise times of AC drives are not identical. Some AC drives have more sophisticated filters and other components designed to minimize undesirable heating and insulation damage to the motor. This must be considered when selecting an AC drive/motor combination.

Distance Between the Drive and the Motor

Distance from the drive to the motor must also be taken into consideration. All motor cables have line-to-line and line-to-ground capacitance. The longer the cable, the greater the capacitance. Some types of cables, such as shielded cable or cables in metal conduit, have greater capacitance. Spikes occur on the output of AC drives because of the charging current in the cable capacitance. Higher voltage (460 VAC) and higher capacitance (long cables) result in higher current spikes. Voltage spikes caused by long cable lengths can potentially shorten the life of the AC drive and motor.

Service Factor on AC Drives

A high efficiency motor with a 1.15 service factor is recommended when used with an AC drive. Due to heat associated with harmonics of an AC drive, the 1.15 service factor is reduced to 1.0.

Matching Motors to the Load

One way to evaluate whether the torque capabilities of a motor meet the torque requirements of the load is to compare the motor's speed-torque curve with the speed-torque requirements of the load.

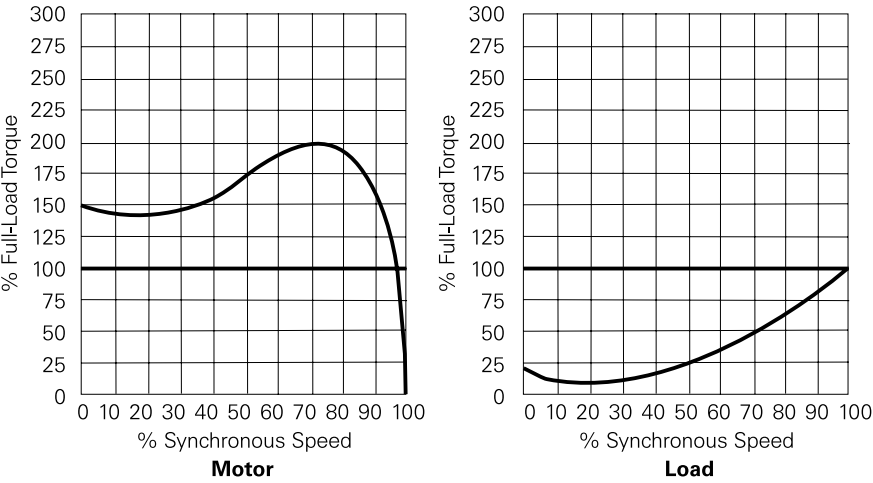

Load Characteristics Tables

A table, like one shown below, can be used to find the load torque characteristics. NEMA publication MG 1 is one source of typical torque characteristics.

Load Description	Load Torque as % Full-Load Drive Torque		
	Break-away	Accelerating	Peak Running
Actuators:			
Screw-down (rolling mills)	200	150	125
Positioning	150	110	100
Agitators			
Liquid	100	100	100
Slurry	150	100	100
Blowers, centrifugal:			
Valve closed	30	50	40
Valve open	40	110	100
Blowers, positive displacement, rotary, bypassed	40	40	100
Calenders, textile or paper	75	110	100

Calculating Load Torque

The most accurate way to obtain torque characteristics of a given load is from the equipment manufacturer. However, the following procedure illustrates how load torque can be determined. The following illustration shows a pulley fastened to the shaft of a load. A cord is wrapped around the pulley with one end connected to a spring scale. Pull on the scale until the shaft turns and note the force reading on the scale. Then, multiply the force required to turn the shaft by the radius of the pulley to calculate the torque value. Keep in mind that the radius is measured from the center of the shaft.

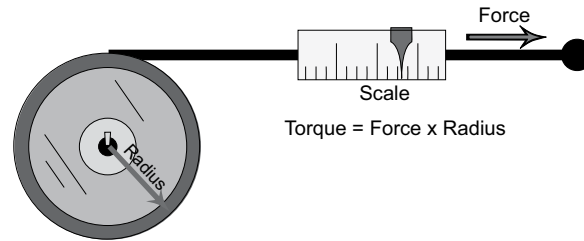

For example, if the radius of the pulley is 1 foot and the force required to turn the shaft is 10 pounds, the torque requirement is 10 lb-ft. Remember that this is just the required starting torque. The amount of torque required to turn the load can vary with speed.

At any point on the speed-torque curve, the amount of torque produced by a motor must always at least equal the torque required by its load. If the motor cannot produce sufficient torque, it will either fail to start the load, stall, or run in an overloaded condition. This will probably cause protective devices to trip and remove the motor from the power source.

Centrifugal Pump

In the following example, a centrifugal pump requires a full-load torque of 600 lb-ft. This pump only needs approximately 20% of full-load torque to start. The required torque dips slightly as the load begins to accelerate and then increases to full-load torque as the pump comes up to speed. This is an example of a **variable torque load**.

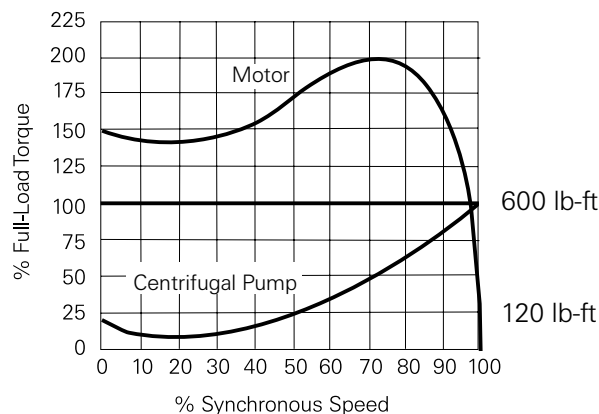

The motor selected in this example is a NEMA B motor that is matched to the load. In other words, motor has sufficient torque to accelerate the load to rated speed.

Screw Down Actuator

In the following example, the load is a screw down actuator with a starting torque equal to 200% of full-load torque. Note that the NEMA B motor chosen for this example does not provide sufficient torque to start the load.

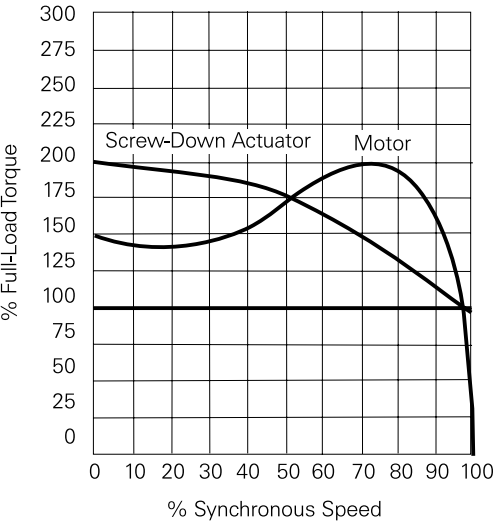

One solution to this problem is to use a higher horsepower NEMA B motor. A less expensive solution might be to use a NEMA D motor which has higher starting torque for the same horsepower rating.

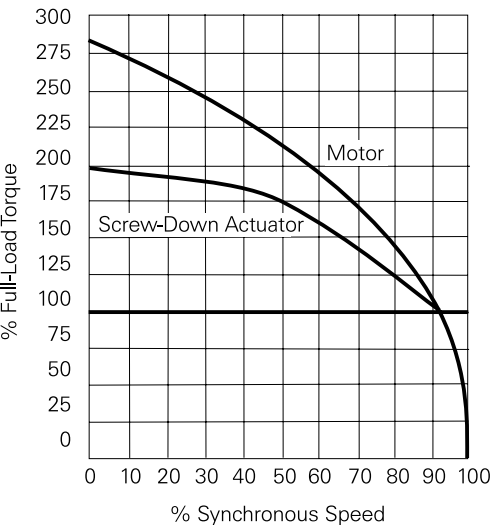

Review 6

1. According to the derating table provided earlier, a 200 HP motor operated at 5500 feet would be derated to _____ HP.
2. The volts per hertz ratio of a 460 Volt, 60 Hz motor is _____ V/Hz.
3. An AC drive in volts-per-hertz mode is in the constant _____ range when it is operating above the motor's base speed.
4. If the radius of a pulley attached to a load shaft is 2 feet, and the force required to turn the shaft is 20 pounds, the amount of torque required to start the load is _____ lb-ft.
5. Which of the loads in the following illustration is properly matched to the motor.
A. Load 1
B. Load 2
C. Load 3
D. Load 4

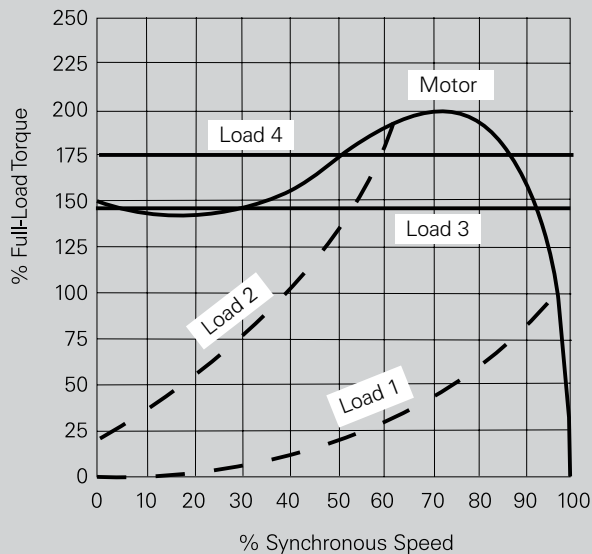

Motor Enclosures

A motor's enclosure not only holds the motor's components together, it also protects the internal components from moisture and contaminants. The degree of protection depends on the enclosure type. In addition, the type of enclosure affects the motor's cooling. There are two categories of enclosures: open and totally enclosed.

Open Drip Proof (ODP) Enclosure

Open enclosures permit cooling air to flow through the motor. One type of open enclosure is the **open drip proof (ODP) enclosure**. This enclosure has vents that allow for air flow. Fan blades attached to the rotor move air through the motor when the rotor is turning. The vents are positioned so that liquids and solids falling from above at angles up to 15° from vertical cannot enter the interior of the motor when the motor is mounted on a horizontal surface. When the motor is mounted on a vertical surface, such as a wall or panel, a special cover may be needed. ODP enclosures should be used in environments free from contaminants.

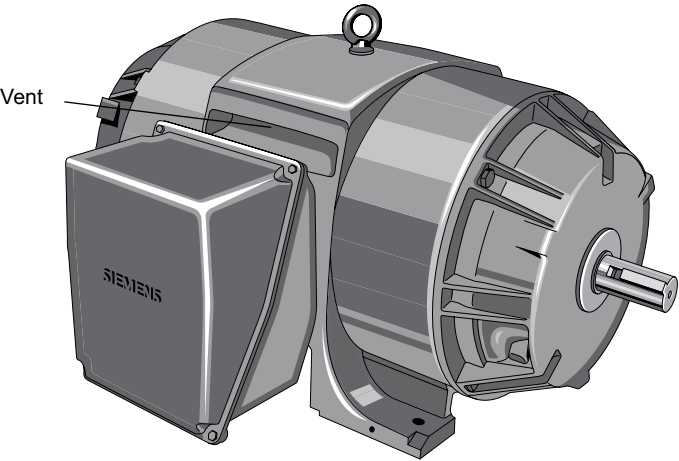

**Totally Enclosed
Non-Ventilated (TENV)
Enclosure**

In some applications, the air surrounding the motor contains corrosive or harmful elements which can damage the internal parts of a motor. A **totally enclosed non-ventilated (TENV) motor** enclosure limits the flow of air into the motor, but is not airtight. However, a seal at the point where the shaft passes through the housing prevents water, dust, and other foreign matter from entering the motor along the shaft.

Most TENV motors are fractional horsepower. However, integral horsepower TENV motors are used for special applications. The absence of ventilating openings means that all the heat from inside the motor must dissipate through the enclosure by conduction. These larger horsepower TENV motors have an enclosure that is heavily ribbed to help dissipate heat more quickly. TENV motors can be used indoors or outdoors.

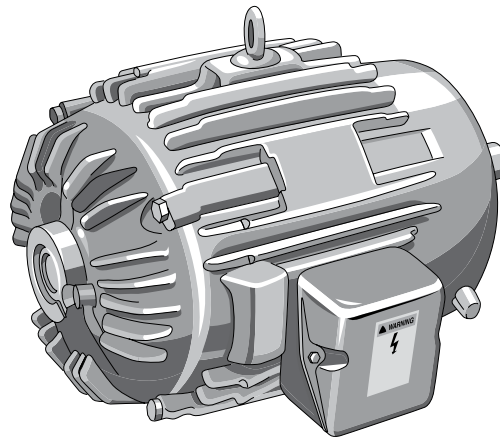

**Totally Enclosed Fan Cooled
(TEFC) Enclosure**

A **totally enclosed fan-cooled (TEFC) motor** is similar to a TENV motor, but has an external fan mounted opposite the drive end of the motor. The fan blows air over the motor's exterior for additional cooling. The fan is covered by a shroud to prevent anyone from touching it. TEFC motors can be used in dirty, moist, or mildly corrosive environments.

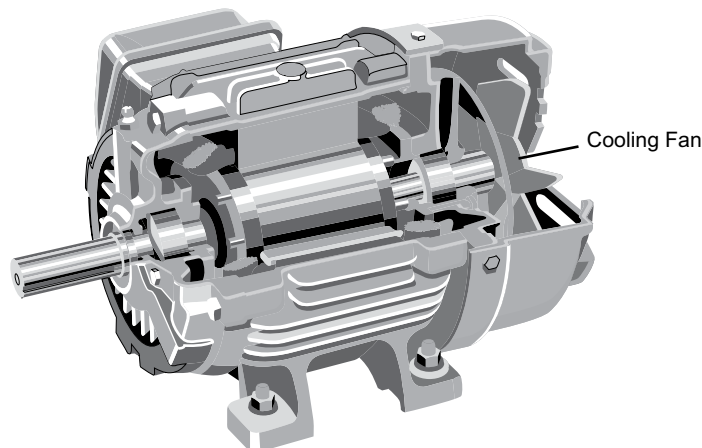

Explosion Proof (XP)

Hazardous duty applications are commonly found in chemical processing, mining, foundry, pulp and paper, waste management, and petrochemical industries. In these applications, motors have to comply with the strictest safety standards for the protection of life, machines and the environment. This often requires use of **explosion proof (XP) motors**.

An XP motor is similar in appearance to a TEFC motor, however, most XP enclosures are cast iron. In the United States, the application of motors in hazardous locations is subject to *National Electrical Code*® and standards set by Underwriters Laboratories and various regulatory agencies.

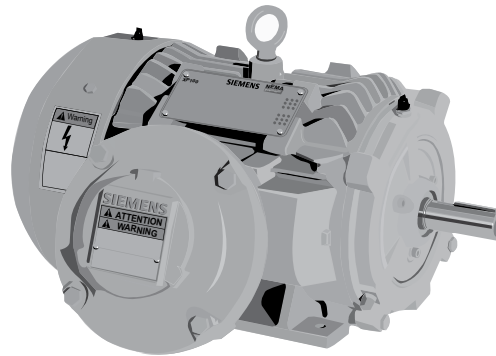

Hazardous (Classified) Locations

You should **never specify or suggest the type of hazardous location classification**, it is **the user's responsibility** to comply with all applicable codes and to contact local regulatory agencies to define hazardous locations. Refer to the *National Electrical Code*® Article 500 for additional information.

Division I and II Locations

Division I locations normally have hazardous materials present in the atmosphere. **Division II locations** may have hazardous material present in the atmosphere under abnormal conditions.

Classes and Groups

Locations defined as hazardous, are further defined by the class and group of hazard. For example, **Class I, Groups A through D** have gases or vapors present. **Class II, Groups E, F, and G** have flammable dust, such as coke or grain dust. **Class III** is not divided into groups. This class involves ignitable fibers and lints.

Classes I	Class II	Class III
Groups A-D Gas or Vapor	Groups E-G Flammable Dust	Flammable Lint or Fibers
Examples: Gasoline Acetone Hydrogen	Examples: Coke Dust Grain Dust	Examples: Textiles Saw Dust

Mounting

NEMA Dimensions

NEMA has **standardized motor dimensions** for a range of frame sizes. Standardized dimensions include bolt hole size, mounting base dimensions, shaft height, shaft diameter, and shaft length. Use of standardized dimensions allows existing motors to be replaced without reworking the mounting arrangement. In addition, new installations are easier to design because the dimensions are known.

Standardized dimensions include letters to indicate the dimension's relationship to the motor. For example, the letter C indicates the overall length of the motor and the letter E represents the distance from the center of the shaft to the center of the mounting holes in the feet. Dimensions are found by referring to a table in the motor data sheet and referencing the letter to find the desired dimension.

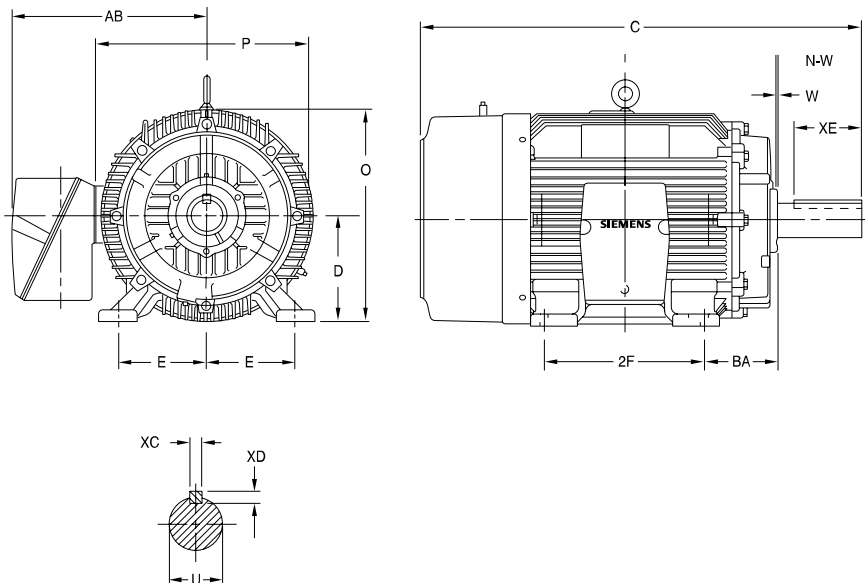

NEMA divides standard frame sizes into two categories, fractional horsepower and integral horsepower. The most common frame sizes for **fractional horsepower motors** are 42, 48, and 56. **Integral horsepower motors** are designated by frame sizes 143 and above. A **T** in the motor frame size designation for an integral horsepower motor indicates that the motor is built to current NEMA frame standards. Motors that have a **U** in their motor frame size designation, are built to NEMA standards that were in place between 1952 and 1964.

The frame size designation is a code to help identify key frame dimensions. The first two digits are used to determine the shaft height. The shaft height is the distance from the center of the shaft to the mounting surface. To calculate the shaft height, divide the first two digits of the frame size by 4. For example, a 143T frame size motor has a shaft height of 3½ inches (14 ÷ 4).

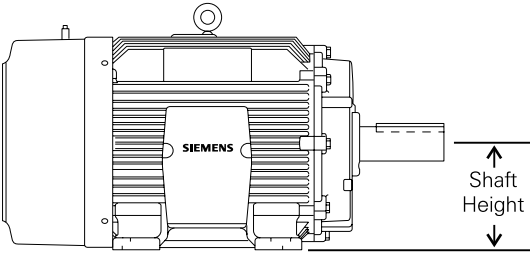

Frame **14**3T
 ↓
 14 ÷ 4 = 3½"

The third digit in the integral T frame size number is the NEMA code for the distance between the center lines of the motor feet mounting bolt holes. The distance is determined by matching this digit with a table in NEMA publication MG-1. For example, the distance between the center lines of the mounting bolt holes in the feet of a 143T frame is 4.00 inches.

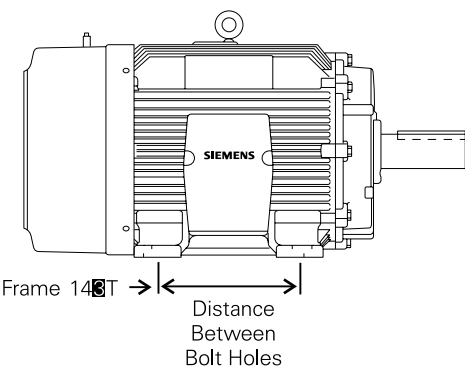

Frame **14**3T → ← →
 Distance
 Between
 Bolt Holes

Frame Number Series	D	Third/Fourth Digit In Frame Number				
		1	2	3	4	5
140				4.00	4.50	4.50
160	4.00	3.50	4.00	4.50	5.00	5.00
180	4.50	4.00	4.50	5.00	5.50	5.50
200	5.00	4.50	5.00	5.50	6.50	6.50
210	5.25	4.50	5.00	5.50	6.25	6.25
220	5.50	5.00	5.50	6.25	6.75	6.75
250	6.25	5.50	6.25	7.00	8.25	8.25
280	7.00	6.25	7.00	8.00	9.50	9.50
320	8.00	7.00	8.00	9.00	10.50	10.50

IEC Dimensions

IEC also has standardized dimensions, but these dimensions differ from NEMA standards. An example of the IEC dimensions are shown in the following drawing.

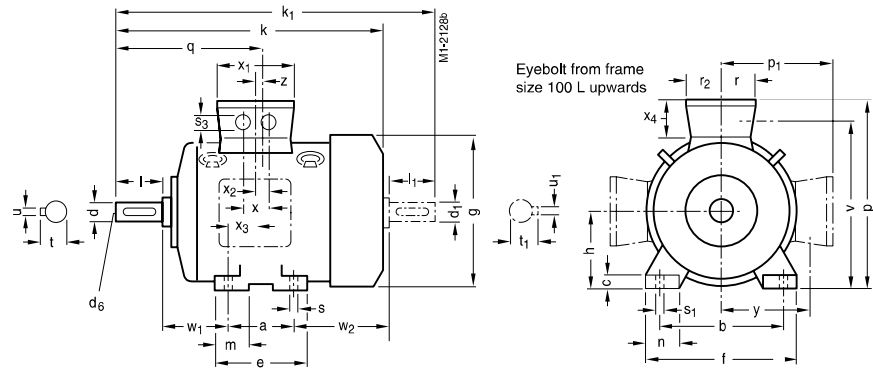

Mounting Positions

The **typical floor mounting positions** are illustrated in the following drawing, and are referred to as F-1 and F-2 mountings. The conduit box can be located on either side of the frame to match the mounting arrangement and position. The standard location of the conduit box is on the left-hand side of the motor when viewed from the shaft end. This is referred to as the F-1 mounting. The conduit opening can be placed on any of the four sides of the box by rotating the box in 90° steps.

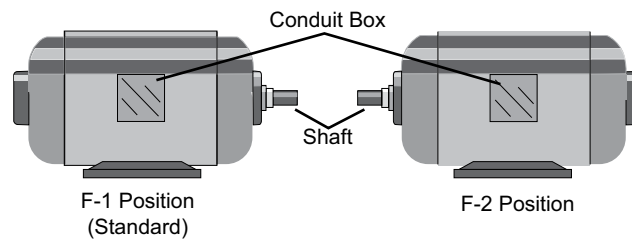

With modification, a foot-mounted motor can be mounted on a wall and ceiling. Typical **wall** and **ceiling mounts** are shown in the following illustration. Wall mounting positions have the **prefix W** and ceiling mounted positions have the **prefix C**.

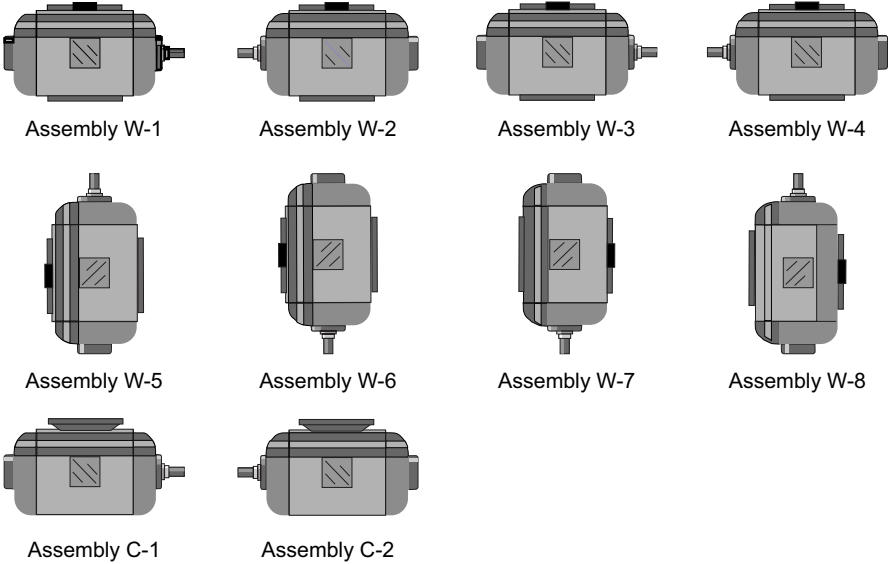

Mounting Faces

It is sometimes necessary to connect the motor directly to the equipment it drives. In the following example a motor is connected directly to a **gear box**.

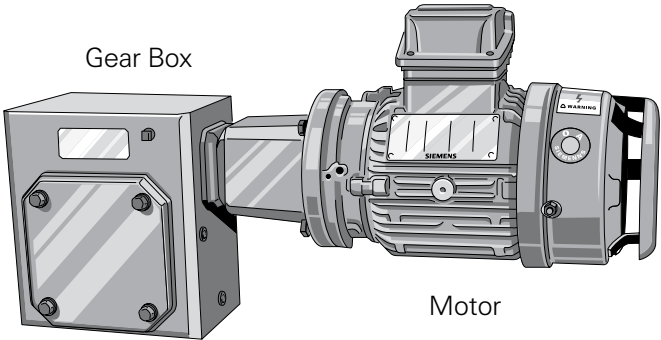

C-face

The face, or the end, of a **C-face motor** has threaded bolt holes. Bolts to mount the motor pass through mating holes in the equipment and into the face of the motor.

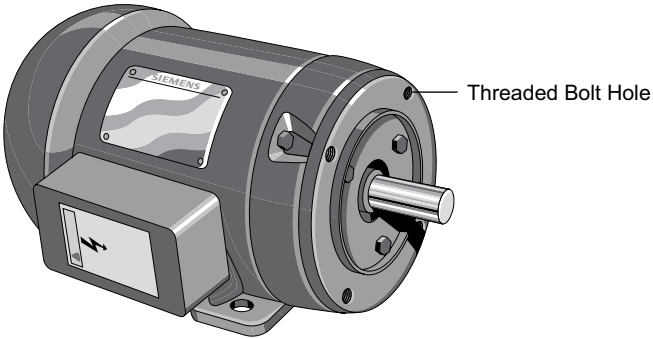

D-flange

The bolts go through the holes in the flange of a **D-flange motor** and into threaded mating holes of the equipment.

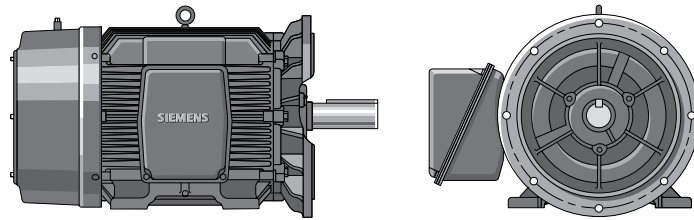

Review 7

1. A type of open enclosure that prevents liquids and solids falling from above at angles up to 15° from vertical from entering the interior of the motor is an _____ enclosure.
2. A type of enclosure that is closed and uses a fan mounted on the motor's shaft to supply cooling air flow is referred to as a _____ enclosure.
3. The letter ____ in a motor's frame size designation indicates that the motor is built to current NEMA standards.
4. The shaft height in inches for an integral horsepower NEMA motor can be determined by dividing the first two digits of the frame size designation by ____.

Siemens AC Induction Motors

Siemens manufactures AC induction motors for a wide range of applications. Our products include motors designed to NEMA or IEC standards, as well as above NEMA motors. This section provides an introduction to these motors. Additional information is available on the Siemens Industry, Inc. web site.

General Purpose NEMA Motors

Siemens **General Purpose NEMA motors** are suitable for a wide range of applications, such as HVAC, material handling, pump, fan, compressor, and other light duty uses in non-hazardous environments.

These motors are available as totally enclosed fan cooled (TEFC) motors in two efficiency levels, **NEMA Premium Efficient** and **Ultra Efficient**. Siemens NEMA Premium Efficient motors meet NEMA Premium efficiency standards and Siemens Ultra Efficient motors with our exclusive die cast copper rotor technology exceed NEMA Premium efficiency standards.

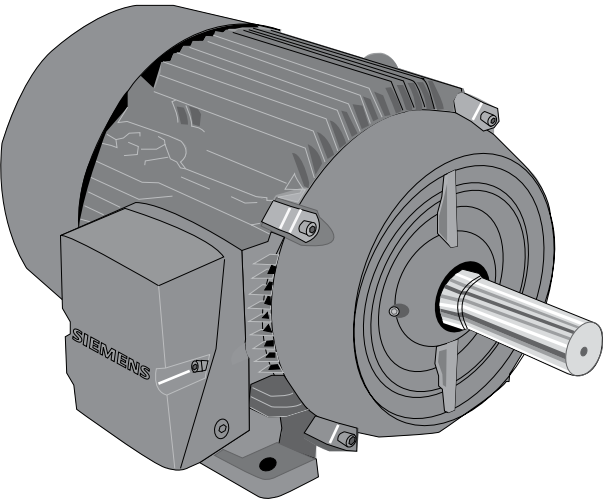

Our General Purpose NEMA motors are manufactured with light-weight die cast aluminum frames or with rugged cast iron frames for reliable, long lasting performance.

Cost Savings with NEMA Premium Efficiency Motors

The following example shows the energy savings over the life of a NEMA Premium efficiency motor. In this example, a 20HP, 1800 RPM, TEFC motor (Motor 1) with an efficiency of 91% and a purchase price of \$675 is compared with a Siemens GP100 NEMA Premium motor with an efficiency of 93.6% and a purchase price of \$1072.

$$C = P + \frac{0.746 \times \text{HP} \times T \times R}{E}$$

C = motor lifecycle cost
 P = initial purchase price
 0.746 = HP to kilowatt conversion factor
 HP = motor full-load horsepower
 T = estimated motor lifetime in hours
 R = utility kilowatt-hour rate
 E = efficiency expressed as a decimal value

Motor 1 Calculation

$$C = \$675 + \frac{0.746 \times 20 \text{ HP} \times 60,000 \text{ Hrs.} \times \$0.08}{0.91} = \$79,373.90$$

GP100 Calculation

$$C = \$1072 + \frac{0.746 \times 20 \text{ HP} \times 60,000 \text{ Hrs.} \times \$0.08}{0.936} = \$77,584.82$$

Total Savings = \$1789.08

Severe Duty Motors

Siemens **Severe Duty motors** are industry workhorses for use in the toughest chemical processing, mining, foundry, pulp and paper, waste management, and petrochemical applications. These motors are available with a wide range of application-matched modifications. Siemens **SD100 severe duty TEFC motors** exceed NEMA Premium efficiency standards. Additionally, Siemens **SD100 IEEE841 severe duty motors** have been designed to exceed the IEEE 841-2001 standards for the petroleum and chemical industries.

Hazardous Duty Motors

In hazardous duty applications, commonly found in chemical processing, mining, foundry, pulp and paper, waste management, and petrochemical industries, motors have to comply with the strictest safety standards for the protection of life, equipment, and the environment. These NEMA Premium efficient motors are UL listed for hazardous gas environments (Class I, Group D, Class II, Groups F & G, Division 1 or Class I, Groups C & D, Division 1). Upgrading to Class II, Group E in a Division 1 area is also available.

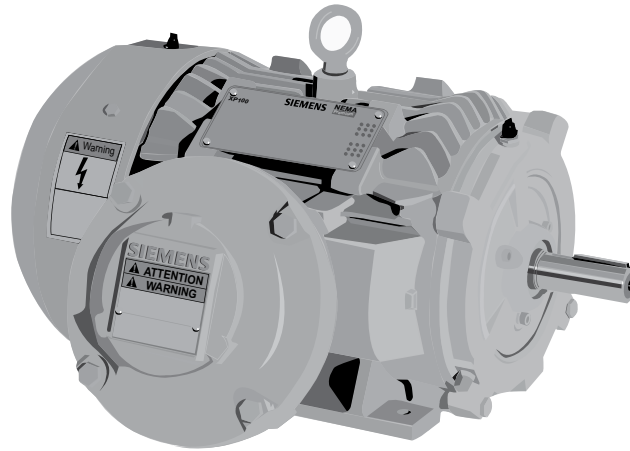

XP100 Explosion-proof Motor

Inverter Duty Motors

Siemens **totally enclosed inverter duty motors** are rated for continuous operation in a 40°C ambient at altitudes up to 3300 feet above sea level. These rugged, high efficient motors exceed EAct Efficiency standards and are manufactured for Severe Duty and Hazardous Duty adjustable speed drive applications such as centrifugal fans, pumps, blowers, mixers, machine tools, chemical processing, mining, foundry, pulp and paper, waste management, and petrochemical.

TEFC Vertical P-Base Motors

Siemens **TEFC Vertical P-Base motors** are the right choice for applications such as centrifugal pumps, turbine pumps, cooling towers, fans, mixers, pulp and paper, petrochemical, irrigation, agriculture, and waste water treatment. These Severe Duty, cast iron motors exceed EAct Efficiency standards and are offered with a solid shaft for Normal, Medium and In-Line Pump thrust applications. Equipped with an insulation system that exceeds the requirements of NEMA MG1 Part 31, Siemens Vertical P-Base motors are suitable for use with variable speed drives.

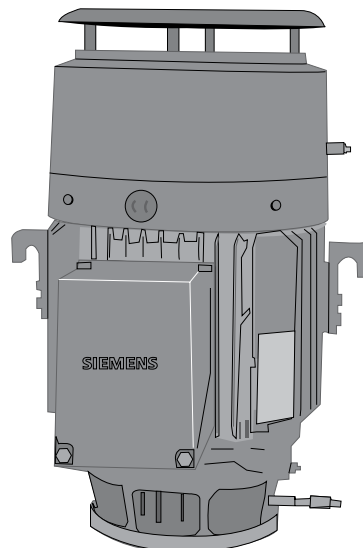

IEC Low Voltage Motors

Siemens offers a complete range of **IEC low voltage motors** in sizes from 0.06 to 1250 kW. The following paragraphs summarize the IEC low voltage motor types available.

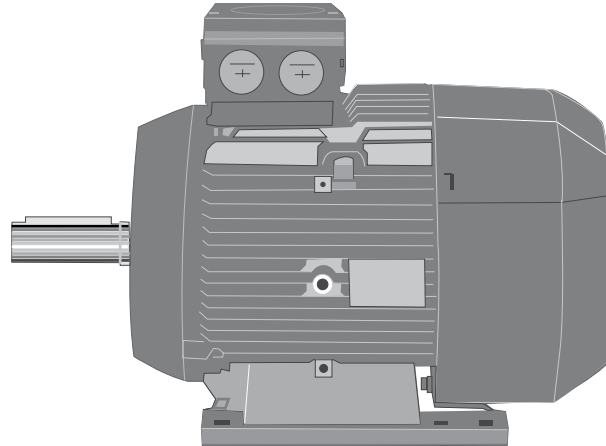

IEC Standard Motors (Up to Frame Size 315L)

Siemens **IEC Standard motors** are characterized by their flexibility, ruggedness and energy efficiency. In general, all motors are suitable for converter-fed operation with line voltages of up to 500 V +10%. These motors are designed to fulfill the requirements of the European and international markets with an output range from 0.06 to 250 kW.

IEC Non-Standard Motors (Frame Size 315 and Above)

Siemens **IEC motor series N compact** includes outputs up to 1250 kW (at 50 Hz) in the non-standard range. A number of technical features provide this motor series with its ruggedness, reliability, and long service life. These motors also are characterized by their high output for a small frame size and have an extremely compact, space-saving design. N compact motors have optimized efficiencies to reduce energy cost.

IEC Explosion Protected Motors

Siemens explosion-protected motors exceed basic safety requirements, operating reliably even under the most extreme conditions. In hazardous environments such as chemical plants, the oil industry or gas works, our rugged EEx motors comply with the strictest safety standards for the protection of life, machines and the environment.

IEC Extraction Motors, Marine Motors, Roller Table Motors

Siemens **smoke extraction motors** can cope with high ambient temperatures safely. In the event of an accident, they reduce the heat loading on the building and keep access and escape routes smoke-free. Our certified smoke extraction motors have been specially developed for buildings and construction sites with smoke control systems.

Specially designed for use on ships below deck and for the offshore industry, our **marine motors** meet the requirements of the leading classification authorities (VV, DNV, GL, LRS) and have type-test certificates up to 200kW output.

Our three-phase **roller table motors** for inverter-fed operation are designed to satisfy the high demands of reversing rolling mills. They are designed as totally enclosed asynchronous three-phase motors with a spheroid graphite iron housing, ring ribs, and strengthened bearing brackets.

IEC Inverter Duty Motors

Siemens Low Voltage IEC motors feature the future-oriented insulation system **Durgnit IR 2000** (IR= Inverter Resistance). The Durgnit IR 2000 insulation system uses high-quality enamel wires and insulating materials in conjunction with a resin impregnation that does not contain any solvents. These motors can withstand operation with converters that have IGBT transistors. This allows all our **standard IEC LV motors** to be operated with variable speed drives at voltages up to 500V +5%. Our **specially developed motors**, with special insulation for operation up to 690V +5%, reduce the cost and space when utilized with sinusoidal and dv/dt filters.

IEC Customer-specific Motors

In addition to the motors previously listed, Siemens also manufactures IEC motors to meet specific customer application requirements.

Above NEMA Motors

Motors that are larger than NEMA frame sizes are referred to as **above NEMA motors**. These motors range in power up to 18,000 HP and are constructed to meet specific customer requirements.

For each frame size, Siemens has standard frame dimensions, similar to NEMA dimensions. The following illustrations shows the typical types of dimensions provided for an above NEMA motor.

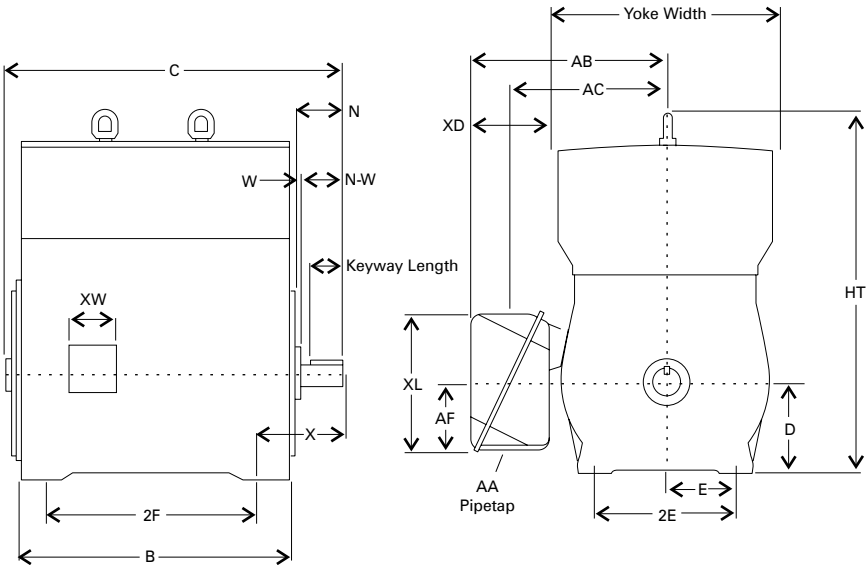

The customer typically supplies specifications for starting torque, breakdown torque, and full-load torque based on speed-torque curves obtained from the driven equipment manufacturer. There are, however, some minimum torques that all large AC motors must be able to develop. These are specified by NEMA.

- Locked Rotor Torque $\geq 60\%$ of Full-Load Torque
- Pull-Up Torque $\geq 60\%$ of Full-Load Torque
- Maximum Torque $\geq 175\%$ of Full-Load Torque

Above NEMA motors require the same adjustments for altitude and ambient temperature as integral frame size motors. When the motor is operated above 3300 feet, either a higher class insulation must be used or the motor must be derated. Above NEMA motors with class B insulation can easily be modified for operation in an ambient temperature between 40° C and 50° C. Motors intended for operation above 50° C ambient temperature require special modification at the factory.

Siemens manufactures a complete line of large AC squirrel-cage induction motors at our ISO-9001 certified plant in Norwood, Ohio. Many of the motors manufactured in this plant are **horizontal, foot-mounted motors**, but this plant also manufactures **vertical, flange-mounted motors**, and **specialty motors**.

Horizontal, Foot-Mounted Above NEMA Motors

Siemens manufactures large, horizontal, foot-mounted motors with a variety of enclosures such as: **open drip proof (ODP)**, **weather protected I (WPI)**, **weather protected II (WP2)**, **totally enclosed water-to-air cooled (TEWAC)**, **totally enclosed air-to-air cooled (TEAAC)**, and **totally enclosed fan cooled (TEFC)**. The following charts summarize Siemens product offerings for large, horizontal, foot-mounted motors.

Enclosure Type	Open Drip Proof/Weather Protected I
Siemens Type	CG
Description	Best suited to indoor applications where it will not be exposed to extreme ambient conditions.
Degree of Protection	IP23 - protected against solid objects greater than 12.5 mm and falling water sprayed at angles up to 60 degrees from vertical.
Type of Cooling	IC01 - open air ventilation
Power Range	200 to 10,000 HP
Poles	2 to 16
Frame Sizes	500, 580, 680, 800, and 1120
Voltage	460 to 13,200 V (460 to 690 V up to 800 HP)
Service Factor	1.0 (1.15 optional)
Enclosure Type	Weather Protected II
Siemens Type	CGII
Description	Designed for outdoor applications where the motor is not likely to be protected by other structures.
Degree of Protection	IP24 - protected against solid objects greater than 12.5 mm and water splashing from any direction.
Type of Cooling	IC01 - open air ventilation
Power Range	200 to 10,000 HP
Poles	2 to 16
Frame Sizes	500, 580, 680, 800, and 1120
Voltage	460 to 13,200 V (460 to 690 V up to 800 HP)
Service Factor	1.0 (1.15 optional)
Enclosure Type	Weather Protected II
Siemens Type	H-Compact PLUS SH710 Frame
Description	Designed for outdoor applications where the motor is not likely to be protected by other structures.
Degree of Protection	IPW 24 - protected against solid objects greater than 12.5 mm and water splashing from any direction. W extends the rating to weather conditions.
Type of Cooling	IC01 - open air ventilation
Power Range	Up to 18,000 HP for 2-pole or 4-pole Up to 12,000 HP for 6 pole Up to 10,000 HP for 8 pole Up to 7,000 HP for 10 pole
Poles	2 to 10
Frame Sizes	710, 712, 714, and 716
Voltage	6,000 to 13,200 V
Service Factor	1.0 (1.15 optional)

Enclosure Type	Totally Enclosed Water-to-Air Cooled
Siemens Type	CGG
Description	Designed for indoor and outdoor applications where internal parts must be protected from adverse ambient conditions. Has the added benefits of low noise and efficient water cooling.
Degree of Protection	IP54 - limits in-flow of dust and protected against water splashing from any direction.
Type of Cooling	ICW81 - water-to-air cooled
Power Range	200 to 10,000 HP
Poles	2 to 16
Frame Sizes	580, 680, 800, and 1120
Voltage	2,300 to 13,200 V
Service Factor	1.0 (1.15 optional)
Enclosure Type	Totally Enclosed Water-to-Air Cooled
Siemens Type	H-Compact PLUS SH710 Frame
Description	Designed for indoor and outdoor applications where internal parts must be protected from adverse ambient conditions. Has the added benefits of low noise and efficient water cooling.
Degree of Protection	IP54 - limits in-flow of dust and protected against water splashing from any direction.
Type of Cooling	ICW81 - water-to-air cooled
Power Range	Up to 18,000 HP for 2-pole or 4-pole Up to 12,000 HP for 6 pole Up to 10,000 HP for 8 pole Up to 7,000 HP for 10 pole
Poles	2 to 10
Frame Sizes	710, 712, 714, and 716
Voltage	6,000 to 13,200 V
Service Factor	1.0 (1.15 optional)
Enclosure Type	Totally Enclosed Air-to-Air Cooled
Siemens Type	CAZ
Description	Designed for indoor and outdoor applications where internal parts must be protected from adverse ambient conditions. Uses air-to-air tube-type heat exchangers.
Degree of Protection	IP54 - limits in-flow of dust and protected against water splashing from any direction.
Type of Cooling	IC611 - totally enclosed air-to-air cooled with shaft mounted external fan
Power Range	900 to 7,000 HP
Poles	2 to 16
Frame Sizes	580, 680, 800, and 1120
Voltage	2,300 to 13,200 V
Service Factor	1.0 (1.15 optional)

Enclosure Type	Totally Enclosed Air-to-Air Cooled
Siemens Type	H-Compact PLUS SH710 Frame
Description	Designed for indoor and outdoor applications where internal parts must be protected from adverse ambient conditions. Uses air-to-air tube-type heat exchangers.
Degree of Protection	IP54 - limits in-flow of dust and protected against water splashing from any direction.
Type of Cooling	IC611 - totally enclosed air-to-air cooled with shaft mounted external fan
Power Range	Up to 18,000 HP for 2-pole or 4-pole Up to 12,000 HP for 6 pole Up to 10,000 HP for 8 pole Up to 7,000 HP for 10 pole
Poles	2 to 10
Frame Sizes	710, 712, 714, and 716
Voltage	6,000 to 13,200 V
Service Factor	1.0 (1.15 optional)
Enclosure Type	Totally Enclosed Fan Cooled
Siemens Type	CZ and CGZ
Description	Designed for indoor and outdoor applications where internal parts must be protected from adverse ambient conditions. Uses cooling fins on all four quadrants of its yoke and housings.
Degree of Protection	IP54 - limits in-flow of dust and protected against water splashing from any direction.
Type of Cooling	IC411 - totally enclosed fan cooled
Power Range	200 to 2,250 HP
Poles	2 to 16
Frame Sizes	500, 580, 708, 788, and 880
Voltage	460 to 11,000 V (460 to 690 V up to 800 HP)
Service Factor	1.0 (1.15 optional)

Vertical, Flange-Mounted Above NEMA Motors

Siemens manufactures large, vertical, flange-mounted motors with a variety of enclosures such as: **open drip proof weather protected I (WPI)**, **weather protected II (WP2)**, **totally enclosed air-to-air cooled (TEAAC)**, and **totally enclosed fan cooled (TEFC)**. The following charts summarize Siemens product offerings for large, vertical, flange-mounted motors with these enclosure types.

Enclosure Type	Weather Protected I
Siemens Type	CGV and CGGS
Description	Best suited to indoor applications where it will not be exposed to extreme ambient conditions.
Degree of Protection	IP23 - protected against solid objects greater than 12.5 mm and falling water sprayed at angles up to 60 degrees from vertical.
Type of Cooling	IC01 - open air ventilation
Power Range	200 to 4,000 HP
Poles	4 to 16
Frame Sizes	500, 580, 680, 800, and 1120
Voltage	2,300 to 13,200 V
Service Factor	1.0 (1.15 optional)

Enclosure Type	Weather Protected II
Siemens Type	CGIIV and CGIHS
Description	Designed for outdoor applications where the motor is not likely to be protected by other structures.
Degree of Protection	IP24 - protected against solid objects greater than 12.5 mm and water splashing from any direction.
Type of Cooling	IC01 - open air ventilation
Power Range	200 to 4,000 HP
Poles	4 to 16
Frame Sizes	500, 580, 680, 800, and 1120
Voltage	2,300 to 13,200 V
Service Factor	1.0 (1.15 optional)
Enclosure Type	Totally Enclosed Air-to-Air Cooled
Siemens Type	CAZV
Description	Designed for indoor and outdoor applications where internal parts must be protected from adverse ambient conditions. Uses air-to-air tube-type heat exchangers.
Degree of Protection	IP54 - limits in-flow of dust and protected against water splashing from any direction.
Type of Cooling	IC611 - totally enclosed air-to-air cooled with shaft mounted external fan
Power Range	800 to 3,000 HP
Poles	4 to 16
Frame Sizes	680, 800, and 1120
Voltage	2,300 to 13,200 V
Service Factor	1.0 (1.15 optional)
Enclosure Type	Totally Enclosed Fan Cooled
Siemens Type	CGZV and CGZHS
Description	Designed for indoor and outdoor applications where internal parts must be protected from adverse ambient conditions. Uses cooling fins on all four quadrants of its yoke and housings.
Degree of Protection	IP54 - limits in-flow of dust and protected against water splashing from any direction.
Type of Cooling	IC411 - totally enclosed fan cooled
Power Range	200 to 900 HP
Poles	2 (4 or 6 optional)
Frame Sizes	500 and 580
Voltage	2,300 to 6,900 V
Service Factor	1.0 (1.15 optional)

Large Specialty Motors

The highly demanding process industries, from oil production and refining to chemical processing and power generation, have adopted two rigorous standards set forth by the American Petroleum Institute for motor reliability and performance. **API 541-4th edition** is for the most critical special purpose motors and **API 547** is for severe-duty general purpose motors. In addition to the above NEMA motors previously listed, Siemens also manufactures large, AC specialty motors to API 541-4th edition and API 547 specifications.

Review 8

1. Siemens General Purpose NEMA motors are available with _____ enclosures.
2. Siemens Severe Duty NEMA motors are available in two efficiency levels, _____ and _____.
3. Siemens totally enclosed inverter duty motors are rated for continuous operation in a 40°C ambient at altitudes up to _____ feet above sea level.
4. Siemens IEC motors are designed to fulfill the requirements of European and international markets with an output range from _____ to _____ kW.
5. Siemens manufactures a complete line of large AC squirrel-cage induction motors at our ISO-9001 certified plant in _____.
6. Siemens above NEMA motors are available in power ranges up to _____ HP.

Review Answers

- Review 1** 1) 15; 2) Torque; 3) 80; 4) inertia; 5) Speed; 6) revolutions per minute or RPM; 7) acceleration
- Review 2** 1) A. enclosure, B. stator, C. rotor; 2) stator; 3) rotor; 4) squirrel cage; 5) enclosure
- Review 3** 1) north, south; 2) A. attract, B. repel, C. repel D. attract; 3) magnetic field; 4) D
- Review 4** 1) 2, north; 2) synchronous; 3) 1800; 4) slip; 5) 4.2
- Review 5** 1) 34.5; 2) 105, 10; 3) 150; 4) breakdown
- Review 6** 1) 188; 2) 7.67; 3) horsepower; 4) 40; 5) A
- Review 7** 1) open drip proof; 2) totally enclosed fan cooled; 3) T; 4) 4
- Review 8** 1) totally enclosed fan cooled; 2) NEMA Premium Efficient, Ultra Efficient; 3) 3300; 4) 0.06, 1250; 5) Norwood, Ohio; 6) 18,000

Final Exam

You can test your knowledge by taking the final exam for this course online at <http://www.usa.siemens.com/step>. This web page provides links to a variety of our quickSTEP online courses. To complete the final exam for this course, click on the **Basics of AC Motors** link.

Next, move your mouse over to the left so that the navigation bar pops out and select the **Final Exam** link. The final exam page will appear. Before taking the final exam, it is recommended that you delete the temporary files on your computer. For most versions of **Internet Explorer**, you can do this by selecting **Internet Options** from the **Tools** menu and then clicking on the **Delete Files** button. If you do not perform this step, you may see a score of 0% after you submit your exam for grading.

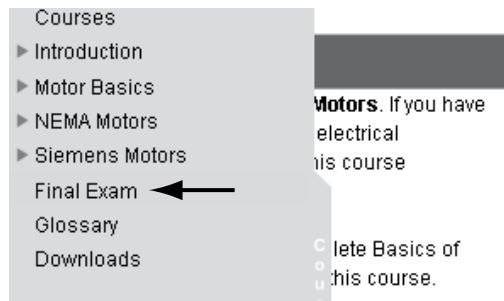

After you complete the final exam, click on the **Grade the Exam** button at the bottom of the page. Your score on the exam will be displayed along with the questions that you missed.

If you score 70% or better on the exam, you will be given two options for displaying and printing a certificate of completion. The **Print Certificate** option allows you to display and print the certificate without saving your score in our database and the **Save Score** option allows you to save your score and display and print your certificate.