

Slide Bearing Type ZM



RENK AKTIENGESELLSCHAFT
Werk Hannover
Weltausstellungsallee 21
D - 30539 Hannover
Telephone: (511) 8601-0
Telefax: (511) 8601-288
e-mail: gleitlager.hannover@renk-ag.com
<http://www.renk.de>

All rights reserved. Copy or reproduction without prior permission of RENK AG, Werk Hannover prohibited.

Contents

Bearing Coding	5
General Drawing Slide Bearing ZM	7
1 Considerations for Use	9
2 Safety Instructions	10
3 Preparatory Work	11
3.1 Tools and equipment	11
3.2 Use of lifting equipment.....	11
3.3 Disassembly of the bearing	13
3.3.1 Disassembly of the housing	13
3.3.2 Disassembly of the inner and outer shaft seal	13
3.4 Cleaning of the bearing.....	14
3.5 Checks.....	15
4 Assembly of the Bearing.....	16
4.1 Assembly of the bottom half of the housing into the machine shield	16
4.2 Fitting in the bottom half of the shell	17
4.3 Assembly of the inner and outer shaft seal	17
4.4 Installation of the loose oil ring	20
4.5 Fitting in the top half of the shell	21
4.6 Assembly of the top half of the housing	22
4.7 Assembly of the baffle for bearing designs with IP 55 protection.....	22
5 Instructions for Assembly of Peripheral Equipment.....	23
5.1 Temperature measurement	23
5.2 Closing the assembly opening.....	23
6 Bearing Insulation.....	23
7 Operation.....	24
7.1 Filling up with lubricating oil.....	24
7.2 Trial run	25

8 Operating Instructions after Standstill (Brief Instructions)	26
9 Maintenance Schedule	27
10 Oil Change	28
11 Disassembly of the Bearing for Maintenance and Inspection	29
11.1 Tools and equipment.....	29
11.2 Use of lifting equipment.....	29
11.3 Preparation for disassembly	31
11.4 Disassembly of the top half of the housing	31
11.5 Disassembly of the baffle IP 55	31
11.6 Disassembly of the inner and outer seals.....	32
11.7 Removing the top half of the shell	32
11.8. Dismantling of the loose oil ring	32
11.9 Removing the bottom half of the shell.....	33
12 Cleaning and Inspection of the Bearing	34
13 Assembly of the Bearing after Inspection	35
14 Starting Operation after Inspection	35
15 Corrosion Protection for Extended Standstill Periods	36
16 Transport Protection	36
17 Glossary	37

Bearing Coding

For example:	ZMNLB	7 - 75
Type	Z	
Housing	M:	centre flange mounted bearing
Heat Dissipation	N:	natural cooling
	W:	water cooling (finned cooler in oil sump)
Shape of Bore and Type of Lubrication	L:	plain cylindrical bore with loose oil ring
Thrust Part	B:	plain sliding surfaces with oil grooves (non-locating or locating bearing)
Bearing Size	7	
Shaft Diameter	75 mm	

General Drawing

Slide Bearing ZM

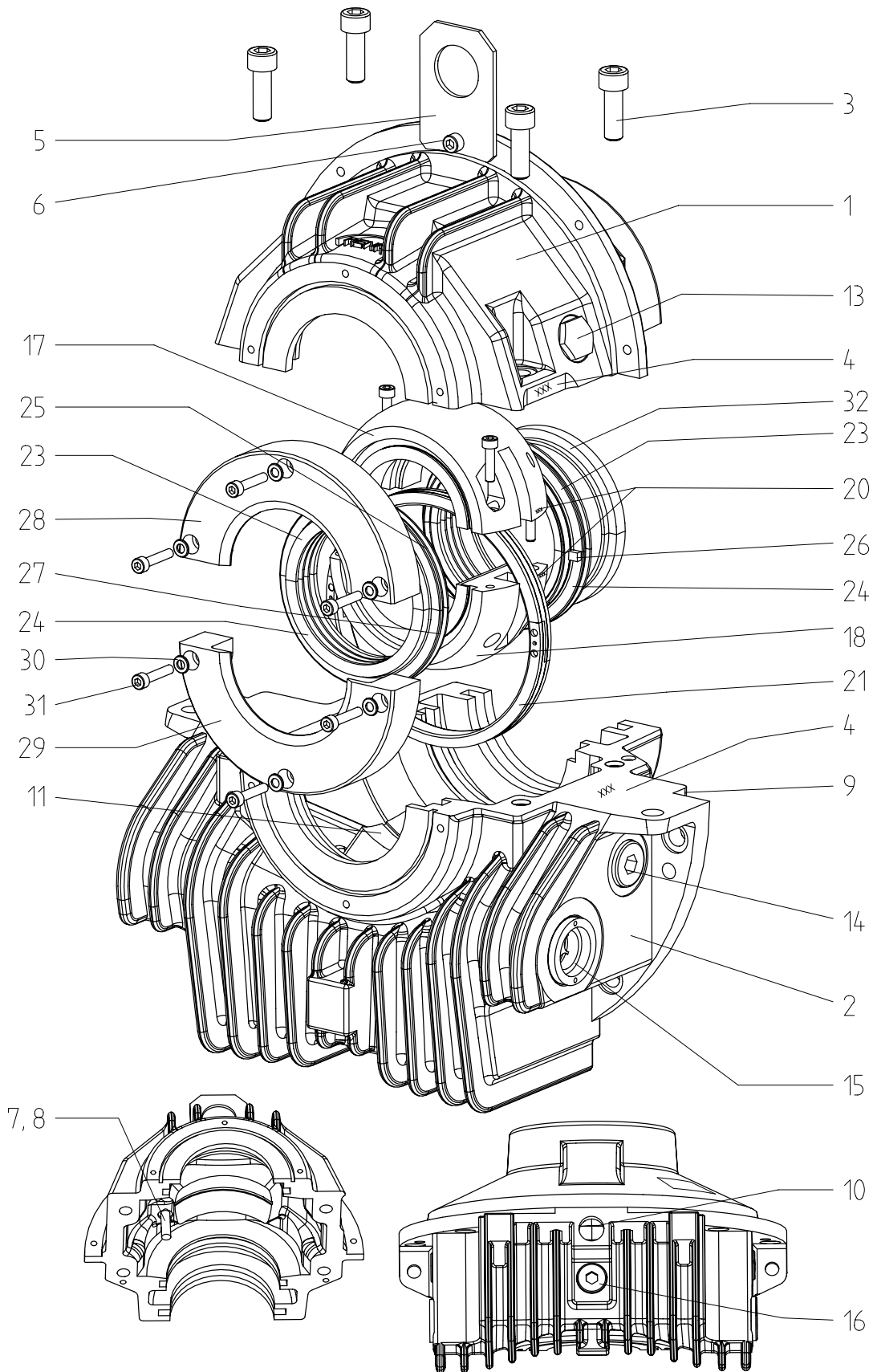

- 1 Top half of the housing
- 2 Bottom half of the housing
- 3 Bolt - split line housing
- 4 Engraved numbers
- 5 Bearing lifting plate
- 6 Screw - lifting plate
- 7 Hole for positioning pin
- 8 Positioning pin
- 9 Housing centering spigot
- 10 Pressure equalizing channel
- 11 Spherical seating
- 12 Tapped hole (screw split line housing)
- 13 Top sight glass / oil filling hole
- 14 Connection hole for temperature measurement
- 15 Oil sight glass
- 16 Flange facing for oil outlet
- 17 Top half of the shell
- 18 Bottom half of the shell
- 19 Screw - split line shell
- 20 Engraved numbers
- 21 Loose oil ring
- 22 Screw for loose oil ring
- 23 Top half of the seal
- 24 Bottom half of the seal
- 25 Spring groove on the back of the seal
- 26 Anti-rotation pin
- 27 Garter spring
- 28 Top half of the baffle
- 29 Bottom half of the baffle
- 30 Washer
- 31 Screw
- 32 split ring

1 Considerations for Use

The instructions for installation, operation, maintenance and inspection are addressed to qualified technical personnel (fitters, mechanic installers, mechanical engineers).

Read these instructions carefully before starting assembly.

Slide bearings type ZM have been especially developed for applications with two-pole electrical machines. In spite of their small size, these bearings show excellent temperature performance. The seal carrier and the air vent port are integral parts of the housing casting. There are drilled and tapped holes on both sides of the bearing housing to accommodate temperature detectors.

Please keep these Instructions ready together with the technical documentation of the devices belonging to the bearing periphery before starting assembly, disassembly, operation, maintenance and inspection of the bearing.

Additional technical documentation with detailed information is supplied in case of bearings of special design. Please contact RENK Export or Domestic Department for supplementary information on bearings. Please indicate the bearing coding and also the full reference number.

Following indications should be observed when reading these instructions.

Safety instructions are marked as follows:



Caution !

Warning of dangers for personnel.
Example: *Warning of injury*

Attention!

Warning of damage for the bearing or installation.

Useful recommendations and additional information are framed.

- Instruction follows.
- Beginning of an enumeration.
- () This is how the different parts of a bearing as described in the general drawings (numbers) are marked in the text.
- Use the enclosed check list before starting assembly or operation. Copies available on request.
- The check list provides the experienced mechanical fitters for RENK bearings with the necessary instructions for installation and operation.

2 Safety Instructions



Caution!

The maintenance and inspection of the slide bearings should be carried out by:

- persons nominated by the safety representative
- persons correspondingly trained and instructed
- persons with knowledge on appropriate standards, regulations and accident prevention rules
- persons with knowledge on first-aid measures and local rescue centres.



Caution!

Before starting work on the bearing:

- Switch off the installation.
- Make sure the installation is not in operation.

Do not use the bearing lifting plate to move or lift machines. The plate is only intended for assembly and dismantling of the bearing !



Caution!

Do not grab such heavy bearing parts as the bearing housing during assembly or dismantling work. This could result in bruising or injury to hands !

Attention !

All parts of a slide bearing consisting of top and bottom halves such as the housing, shells, shaft seals are marked by engraved numbers. Fit together only the parts with the same number.

Attention !

In case

- the admissible bearing temperature exceeds 15 K

- inadmissible vibrations occur
- unusual noises or odours are noticed
- monitoring equipment triggers alarm

shut down the installation and inform the maintenance personnel in charge.

Attention !

Do not operate the bearing below the transition speed values indicated in the computed calculations of the bearing, thus avoiding inadmissible operating conditions, which could lead to damage to the bearing.

Attention!

Please observe our leaflet Technical Information No. 85 which refers to various sealing compounds for extended technical applications.

3 Preparatory Work

3.1 Tools and equipment

– Following tools and equipment are necessary:

- Allan key set
- Wrenching key set
- Open-jawed spanner set
- Feeler gauges (starting from 0,05 mm)
- Caliper gauge
- Emery paper, plain scraper
- Oil stone
- Eye bolts M 10
- Lifting equipment
- Permanent sealing compound
- Clean (close weave) rags
- Oil with the correct viscosity (see bearing type plate)
- Detergents
- Liquid screw locking compound (e.g. LOCTITE 242)
- Liquid sealing compound and Teflon-tape.

3.2 Use of lifting equipment



Caution!

Before using the lifting plate to transport or lift the bearing, check that the bolts at the split line are tight, otherwise the bottom half of the housing could become detached.

Before moving or lifting the bearing, make sure the screw of the bearing lifting plate is tight. If the screw is not tight, the bearing or the top half of the bearing could become detached and drop down.

Before transport/lifting, check if the eye bolts mounted to bottom half of the housing are tight. Insecure eye bolts could result in the bottom half of the housing becoming loose.

Make sure that the eye bolts are not exposed to bending stress, otherwise the bolts could break.

Follow exactly the instructions for the use of the lifting equipment.

Installation, Operation, Maintenance and Inspection

The instructions below refer to how you prepare correctly the bearing for the use of the lifting equipment.

Whole bearing

- Make sure the bolts (3) at the split line are tight.

Bolt size	M 10
Torque [Nm] for yield tightening $\mu_{\text{total}} = 0,10$ (slightly oiled), torque factor 1,0	40
Torque [Nm] for torque controlled tightening with torque wrench $\mu_{\text{total}} = 0,10$ (slightly oiled), torque factor 1,6	32

- Mount the bearing lifting plate (5) to the tapped hole provided on the top half of the housing.
- Check that the lifting plate is tight.
- Connect the lifting equipment to the bearing lifting plate (5).

Top half of the housing

- Mount the bearing lifting plate (5) to the tapped hole provided on the top half of the housing.
- Check that the lifting plate (5) is tight.
- Connect the lifting equipment to the bearing lifting plate (5).

Bottom half of the housing

- Screw two eye bolts M 10 tight into the cross-placed opposite tapped holes (12).
- Connect the lifting equipment to the eye bolt.

3.3 Disassembly of the bearing

Attention !

Make sure that the work place and the parts to be assembled are clean. Contamination and damage to the bearing, especially of the working surfaces, have a negative influence on the operating quality and could lead to premature failure.

Attention !

Carry out all operations without making use of violence or force.

3.3.1 Disassembly of the housing

- Unscrew the four bolts (3) at the split line of the housing and lift the top half of the housing (1) in vertical direction.
- Remove the top half of the shell (17) and the bottom half of the shell (18) from the bottom half of the housing (2).

Attention !

Do not damage the thrust and journal working surfaces.

- Unscrew and remove both screws (19) at the split line of the shell and separate the top half of the shell (17) and the bottom half of the shell (18) without using any tools or other devices.

The split rings (32) are already mounted and you do not have to remove them for cleaning the bearing.

3.3.2 Disassembly of the inner and outer shaft seal

Both the inner and the outer shaft seal are floating labyrinth seals.

- Remove the floating labyrinth seal from the bottom half of the housing.
- Take both halves of the seal (23), (24) by the split line. Pull both halves apart until you can press out the protective cardboard. Remove the cardboard by pressing carefully along the edge of the split line.



Caution!

During disassembly of the seal hold on tight to the tensioned garter spring (27) which otherwise could bounce back and lead to injury.

- Take both seal halves (23), (24) and pull them apart by approx. 20 mm. Tilt both halves backwards.
- Unhook the garter spring (27).

3.4 Cleaning of the bearing

Attention!

Use only non-aggressive detergents, such as for instance:

- VALVOLINE 150.
- Alkaline cleaning compounds (pH-value 6 to 9, short reaction time).



Caution!

Please observe the instructions for the use of the detergents.

Attention!

Never use cleaning wool or loosely woven cloth. Residues of such materials left in the bearing could lead to excessive temperatures and therefore to damage to the bearing.

- Clean thoroughly, removing all traces of grease, oil, preservatives, etc. from the following parts:
 - inside the top half of the housing (1)
 - inside the bottom half of the housing (2)
 - all plain surfaces of the top and bottom half of the housing (1), (2)
 - top half of the shell (17)
 - bottom half of the shell (18)
 - the flange and split line surfaces of the bottom and top half of the baffle (28), (29).

3.5 Checks

- Carry out a visual checking of all parts. Check carefully the split and working surfaces. The loose oil ring (21) should show absolutely no burrs or have no shoulders.
- For bearing designs with insulation (optional): Check the insulating layer of the spherical seating (11) in the housing.
- If necessary, replace the damaged parts. You need special tools to replace the insulating layer.
- Check if the floating labyrinth seal moves freely around the shaft in the sealing area.

**Caution!**

During assembly hold the garter spring (27) ends securely to avoid them suddenly releasing and causing possible injury.

- Place the garter spring (27) around the shaft and hook both ends into each other.
- Put both halves of the seal (23), (24) in their place around the shaft.
- Place the garter spring (27) into the spring groove (25) on the back of the seal.
- Turn the floating labyrinth seal around the shaft.

Attention!

Make sure the floating labyrinth seal rotates easily around the shaft. A jammed seal could lead to temperature increase during operation and consequently to wear of the shaft.

If the floating labyrinth seal jams

- dismantle the seal and
- remove the worn parts of the seal carefully, by using emery paper or a plain scraper.

- After checking, dismantle the floating labyrinth seal again.

4 Assembly of the Bearing

Attention!

Make sure the work place is perfectly clean. Contamination or damage of the bearing and of the working surfaces in particular, impair operation and could lead to premature wear and even to damage to the bearing.

Attention!

Remove all screws, nuts, dirt, metal chips, etc. If left in the bearing they could lead to damage to the bearing. Cover up the opened bearing during work breaks.

Attention!

Carry out all assembly steps without making use of force or violence.

Attention!

Make sure the shaft in the bearing area is clean and in perfect condition.

Before assembly, check the bedding pattern of the shaft and of the shell (blue marker test).

Attention!

After assembly secure all screws of the housing, the screws at the split line and the flange screws of the shaft seals with liquid screw locking compound (e.g. LOCTITE 242).

4.1 Assembly of the bottom half of the housing into the machine shield

Attention!

The lifting equipment should not come in touch with the sealing and working surfaces of the shaft.

- Lift the shaft high enough to have sufficient place for the assembly operations.
- Protect the shaft against unintended movement.
- Screw two eye bolts into the opposite tapped holes (12).
- Place the bottom half of the housing with the centering spigot (9) into the recess provided in the machine shield.
- Unscrew and remove the two eye bolts.
- Insert the flange screws and tighten them according to the values indicated in the table below.
- Use screws of quality class 8.8.

Screw size	M 10
Torque [Nm] for yield tightening $\mu_{\text{total}} = 0,10$ (slightly oiled), tightening factor 1,0	40
Torque [Nm] for torque controlled tightening with torque wrench $\mu_{\text{total}} = 0,10$ (slightly oiled), tightening factor 1,6	32

4.2 Fitting in the bottom half of the shell

- Apply some lubricant to the spherical seating (11) in the bottom half of the housing (2) and to the working surfaces of the shaft. Use the same type of lubricant as indicated for the bearing operation (see bearing type plate).
- Place the bottom half shell (18) onto the shaft journal. Turn the bottom half shell (18) into the bottom half of the housing (2) in such a way so that the split lines of both parts are in true alignment.

In case the bottom half of the shell does not rotate easily, check the jacked position of the shaft.

Attention !

Carefully place and rotate the bottom half of the shell between the shaft collars.
Do not damage the thrust faces of the bottom half of the shell.

- Gently lower the shaft until it sits on the bottom half of the shell (18).

4.3 Assembly of the inner and outer shaft seal

The inner and outer shaft seal are the standard type of floating labyrinth seal. The grooves which take the seal are provided in the top and bottom half of the housing.



Caution!

During assembly hold the garter spring (27) ends securely to avoid them suddenly releasing and causing possible injury.

Attention!

Make sure the floating labyrinth seal rotates easily around the shaft. A jammed seal could lead to temperature increase during operation and consequently to wear of the shaft.

If the floating labyrinth seal jams

- dismantle the seal and
- remove the worn parts of the seal carefully, by using emery paper or a plain scraper.

- Apply a layer of sealing compound to the guiding surfaces of the groove provided in the bottom half of the housing.

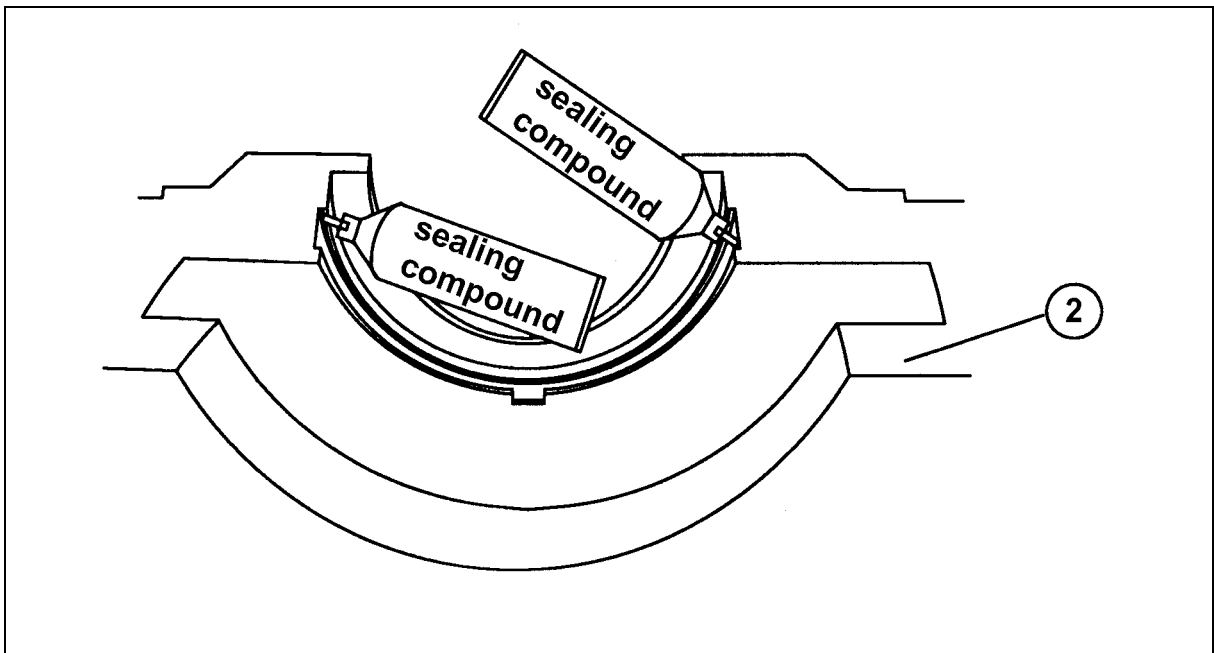

Illustration 1: Applying sealing compound to the sealing area

- Apply a uniform layer of sealing compound to the guiding surfaces and split line surfaces of both halves of the seal (23), (24).

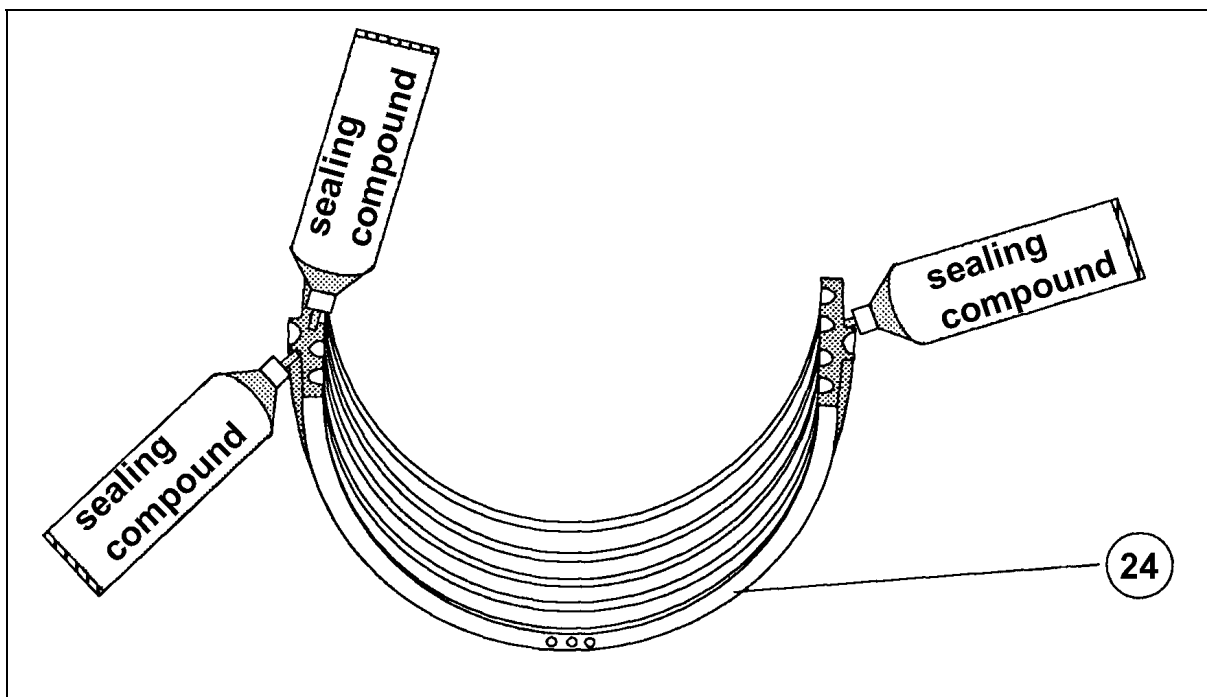

Illustration 2: Application of sealing compound to the floating labyrinth seal

Observe the instructions for the use of sealing compound.

- Place the bottom half of the seal (24) with the baffles on the shaft.
- Make sure the oil return opening is on the inside of the bearing.
- Put the side without anti-rotation pin (26) of the bottom half of the seal into the guiding groove of the housing side provided with the anti-rotation groove. Make sure the split lines terminate flush with each other.
- Remove the surplus of sealing compound at the split line.
- Push the garter spring into the spring groove (25) at the back of the seal between the bottom half of the housing and the bottom half of the seal until both ends protrude at the split line.
- Place the top half of the seal on the bottom half of the seal. Both halves should match at the split line.
- Stretch the garter spring until both ends can be hooked.

4.4 Installation of the loose oil ring

- Open both split lines of the loose oil ring (21) by untightening and removing the screws (22). Separate both halves of the loose oil ring (21) carefully without using any tools or other devices.

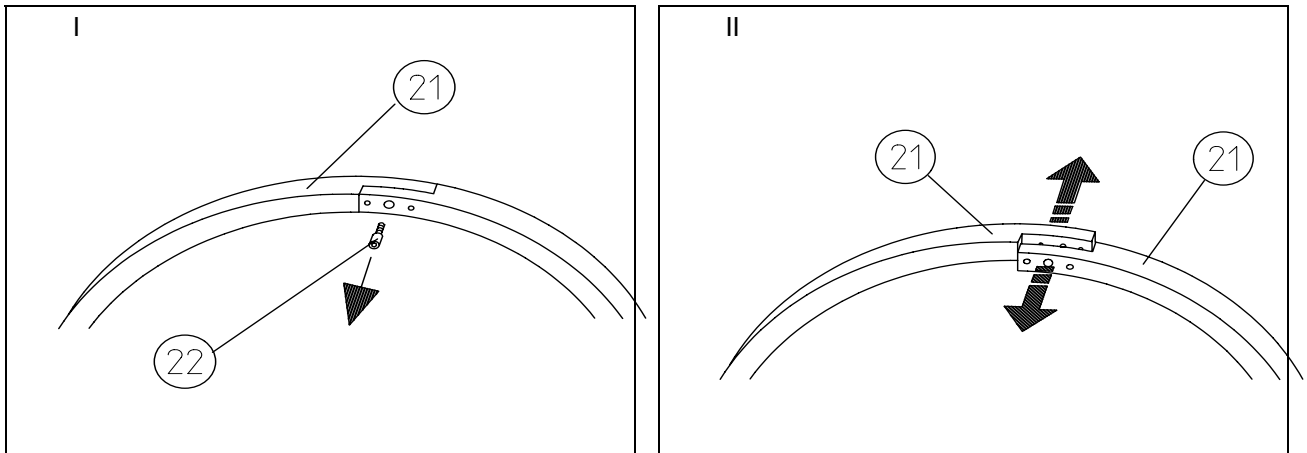

Illustration 3: Opening of the loose oil ring

- Place both halves of the loose oil ring into the shell groove encircling the shaft. Press the positioning pin of each split line into the corresponding hole.
- Adjust both halves of the loose oil ring till the split lines match each other.

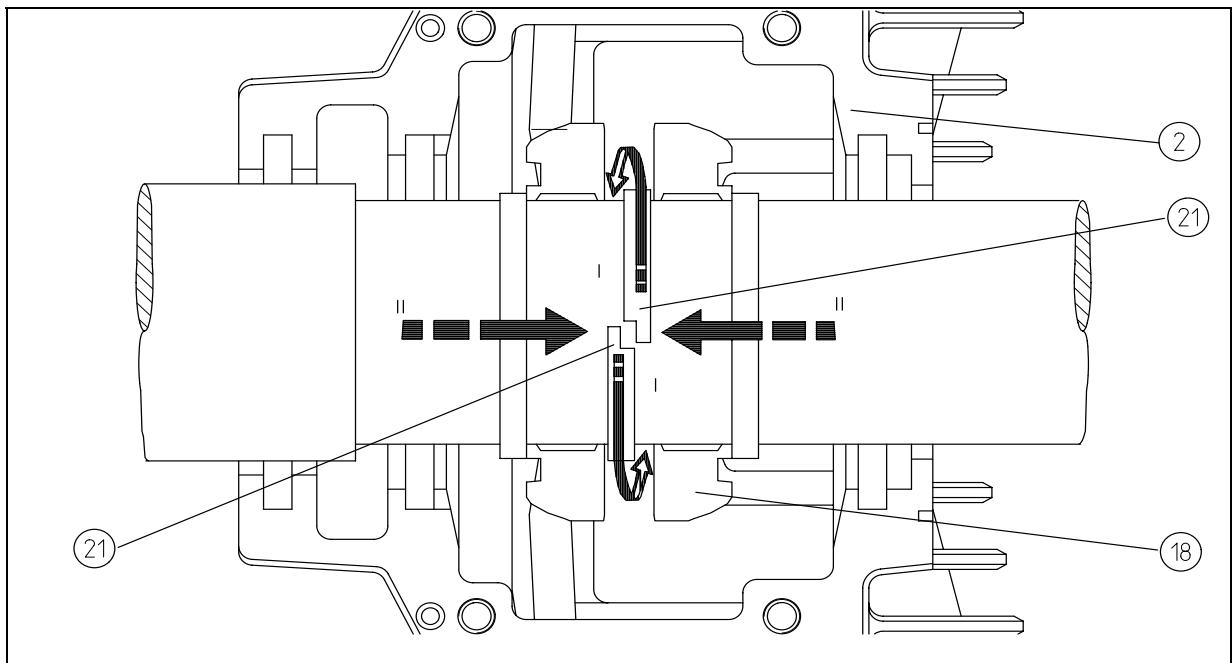

Illustration 4: Installation of the loose oil ring

- Tighten the screws M 2,5 (22) by using the torque value of 0,75 Nm.

4.5 Fitting in the top half of the shell

- Apply some lubricant to the working surfaces of the shaft. Use the same type of lubricant as indicated for the bearing operation (see bearing type plate).
- Check if the engraved numbers (20) on the bottom and top half of the shell correspond.
- Place the top half of the shell (17) on the shaft; the engraved numbers (20) should be on one side.

Attention!

An incorrect placed shell could jam the shaft thus leading to damage to the shaft and to the bearing.

Attention!

Place the top half of the shell carefully between the shaft collars. Do not damage the thrust surfaces of the top half of the shell.

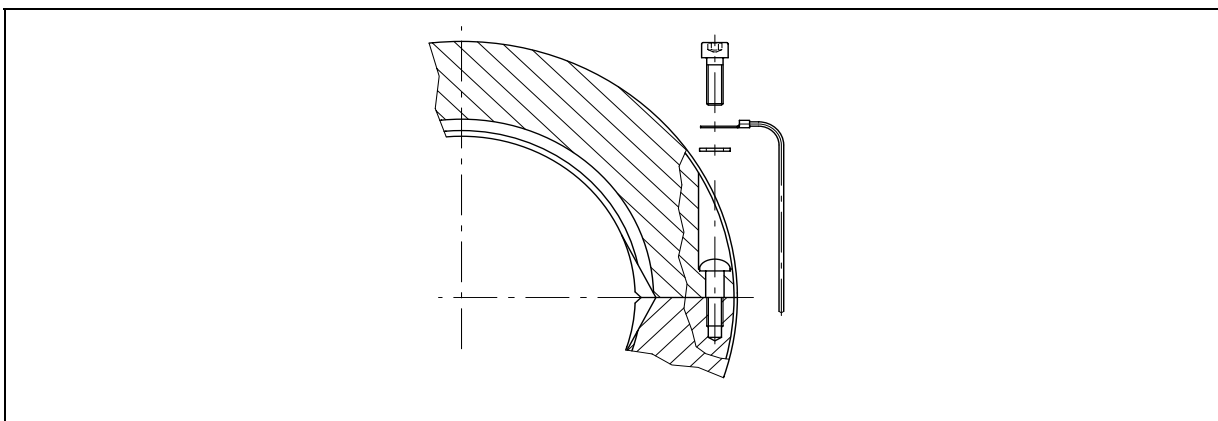

Illustration 5: Assembly of the insulation monitoring

- In the case of bearings provided with insulation monitoring (optional) connect the washer and the cable with the crimp type socket to the screws of the split line of the shell.
- Tighten the screws at the split line (19) to the torque indicated below:

Thread size	M 5
Torque [Nm] for yield tightening $\mu_{total} = 0,10$ (slightly oiled), tightening factor 1,0	4,5
Torque [Nm] for torque controlled tightening with torque wrench $\mu_{total} = 0,10$ (slightly oiled), tightening factor 1,6	3,6

- Check the split line gap of the shell by using a feeler gauge. The split line gap should be smaller than 0,05 mm. If the gap is larger, dismantle both top and bottom halves of the shell (17), (18). Rework the split line surfaces of the top and bottom halves of the shell (17), (18) with an oil stone.
- Check the mobility of the loose oil ring (21).
- Lead the cable for insulating monitoring (optional) through the cable gland provided on the bottom half of the housing (2) and pull it out of the bearing.

Attention!

Make sure the cable does not obstruct the mobility of the loose oil ring (21).

4.6 Assembly of the top half of the housing

- Check the true alignment of the split lines of the shell (17), (18) and of the bottom half of the housing (2).

In this way it is ensured that when placing the top half of the housing the positioning pin (8) gets engaged into the corresponding hole (7). The shell is in the correct position.

- Make sure the engraved numbers (4) on the top and bottom half of the housing correspond.
- Clean the split lines surfaces of the top and bottom half of the housing.
- Apply a uniform layer of sealing compound to the split line surfaces of the bottom half of the housing (2).
- Apply a uniform layer of sealing compound to the guiding surfaces of the groove of the inner and outer seal. Proceed as described above for the bottom half of the housing.

Please observe the instructions for the use of sealing compound.

- Carefully mount the top half of the housing to the machine shield without damaging the seals or touching the shell.
- Lower the top half of the housing (1) vertically onto the bottom half (2) until the split line is completely closed.
- Gently hit the bottom half of the housing (2) with a nylon hammer, thus ensuring the alignment of the spherical seating.
- Insert the four bolts (3). Tighten them crosswise to the following torque:

Bolt size	M 10
Torque [Nm] yield tightening $\mu_{\text{total}} = 0,10$ (slightly oiled), torque factor 1,0	40
Torque [Nm] for torque controlled tightening with torque wrench $\mu_{\text{total}} = 0,10$ (slightly oiled), torque factor 1,6	32

- Remove the bearing lifting plate (5) from the flange of the top half of the housing and stow it on the cover plate of the machine shield.

4.7 Assembly of the baffle for bearing designs with IP 55 protection

- Clean the flange and split line surfaces of the bottom half (29) and top half (28) of the baffle as well as the flange surfaces of the housing.
- Apply some sealing compound to the flange surfaces of the bottom half (29) and top half (28) of the baffle.
- Tighten the bottom half of the baffle (29) to the bottom half of the housing (2) by slightly pressing the baffle against the shaft. The baffle should slightly touch the shaft.
- Tightly fasten the top half of the baffle (28) to the top half of the housing (1).
- Make sure that all split line surfaces of the baffle are in true alignment.
- Tighten the screws M 5 (31) to a torque value of 4 Nm.

5 Instructions for Assembly of Peripheral Equipment

5.1 Temperature measurement

- Mount thermo sensors for temperature measurement of the journal part to the connection hole (14) (diameter of the sensor 6 mm maximum).

Proceed as follows:

- Remove the plug from the connection hole.
- Insert the thermo sensor by using Teflon tape and liquid sealing compound.
- Connect the thermo sensor to the temperature monitoring of the unit (see the technical documentation of the installation).

5.2 Closing the assembly opening

- After completion of bearing assembly and before starting operation close the assembly opening in the machine shield with a cover plate.

6 Bearing Insulation

The bearings are delivered insulated. The electrical insulation is ensured by:

- plastic coating of the spherical seating (15)
- shaft seals made of non-conducting materials
- insulated positioning pin (8).

The user should insulate the temperature monitoring unit correspondingly (e.g. by using insulated protective tubes, plastic screws, etc.) (diameter of the sensor 6 mm maximum).

No insulation of the pipe lines is required.
--

7 Operation

7.1 Filling up with lubricating oil

Attention!

Make sure that no impurities get into the bearing.

- Tighten the plugs closing the connections holes (14), (15), (16) to the torque indicated below:

Threads	G 1/2	G 1
Torque [Nm] for plugs with moulded on plastic seal	40	110
Torque [Nm] for plugs with elastic seal	60	130

- Check if the oil sight glass (15) is tight, the screws should be hand-tight.
- Remove the screw plugs from the oil filling hole (13).
- Fill the lubricant through the oil filling hole (13) up to the middle point of the oil sight glass (15). Use a lubricant with the viscosity indicated on the bearing type plate.
The oil level limits are as follows:

minimum oil level: bottom of the oil sight glass

maximum oil level: top of the oil sight glass

- In case a thermo sensor is used, check if it is tight (according to the manufacturer's instructions).

Attention!

- Not enough lubricant leads to temperature rises and thus to damages to the bearing.
- Too much lubricant leads to leakages. In the case of bearings with lubrication by loose oil ring too much lubricant could brake the oil rings considerably, thus leading to damages to the bearing.

- Tighten the oil sight glass into the oil filling hole (13) hand-tight.

7.2 Trial run

- Before trial run check:
 - the oil level (according to chapter 7.1)
 - if the temperature monitoring equipment works.

The bearing is ready for operation.

- Supervise the bearing during the trial run (5 - 10 operating hours).
Pay special attention to
 - the oil level
 - bearing temperature, temperature progression
 - sliding noises in the shaft seal area
 - tightness
 - occurrence of inadmissible vibrations.

Attention !

If the bearing temperature exceeds the calculated value by more than 15 K (see bearing computed calculations) stop the installation immediately. Carry out an inspection of the bearing, as described in this manual, Chapter 11 - 14.

8 Operating Instructions after Standstill (Brief Instructions)

- Clean all external parts of the bearing.

Attention!

After an extended standstill period, dismantle the bearing, remove the bag of silicate gel and clean the bearing (see Chapter 11 + 12 of this Manual).

- Consult the instructions for the use of the lubricant to find out if an oil change is necessary. Depending on the duration of the standstill, an oil change is either prescribed or recommended. Carry out the oil change as described in the corresponding chapter of this Manual.
- Check the oil level. Use a lubricant with the viscosity indicated on the bearing type plate. Fill the lubricant through the oil filling hole (13) up to the middle point of the oil sight glass (15). The oil level limits are as follows:

minimum oil level: bottom of the oil sight glass

maximum oil level: top of the oil sight glass

- Tighten the screws at the split line (3) and the flange screws to the following torque:

Flange screws / screws at split line	M 10
Torque [Nm] for yield tightening $\mu_{\text{total}} = 0,10$ (slightly oiled), torque factor 1,0	40
Torque [Nm] for torque controlled tightening with torque wrench $\mu_{\text{total}} = 0,10$ (slightly oiled), torque factor 1,6	32

- Check if:
 - the top sight glass (13) is tight, the screws should be hand-tight.
 - the oil sight glass (15) is tight, the screws should be hand-tight.
- In case a thermo sensor is used, check if it is tight (according to the manufacturer's instructions).
- Tighten all plugs closing the connections holes (14), (15), (16) to the torque indicated below:

Threads	G 1/2	G 1
Torque [Nm] for plugs with moulded on plastic seal	40	110
Torque [Nm] for plugs with elastic seal	60	130

- Check if the temperature monitoring equipment works.

The bearing is ready for operation.

9 Maintenance Schedule

Maintenance work	Deadline
Exterior cleaning of the housing	every 100 - 1000 hours
Oil change	Turning operation every 5.000 operating hours Continuous operation every 8.000 operating hours (Observe the indications for the use of the lubricant)
Inspection of the bearing	During prevention maintenance work. - Immediately if <ul style="list-style-type: none"> • the bearing temperature exceeds by more than 15 K over the indicated value (see EDP-calculations) • unusual operating noises occur • you notice unusual modifications of the lubricant.

10 Oil Change

Risk of pollution!

Please observe the instructions for the use of the lubricant. The manufacturer can provide information on waste oil disposal.

- Shut down the installation and secure it against unintended operation.
- Take all necessary measures to collect the whole quantity of lubricant.
- Drain off the lubricant while it is still warm. Impurities and residues will thus be scavenged. Proceed as follows:
- Remove the oil outlet plug (16). Drain off the lubricant and collect it in a suitable container.

Attention!

In cases where the lubricant contains unusual residues or has visibly changed, eliminate the causes. If necessary, carry out an inspection of the bearing.

- Tighten the oil outlet plug (16) to the following torque rate.

Threads	G 1/2	G 1
Torque [Nm] for plugs with moulded on plastic seal	40	110
Torque [Nm] for plugs with elastic seal	60	130

- Remove the oil sight glas from the oil filling hole (13).

Attention!

Make sure that no impurities get into the bearing.

- Fill the lubricant through the oil filling hole (13) up to the middle point of the oil sight glass (15). Use a lubricant with the viscosity indicated on the bearing type plate. The oil level limits are as follows:

minimum oil level: **bottom of the oil sight glass**

maximum oil level: **top of the oil sight glass**

Attention!

- Not enough lubricant leads to temperature rises and thus to damages to the bearing.
- Too much lubricant leads to leakages. In the case of bearings with lubrication by loose oil ring too much lubricant could brake the oil rings considerably, thus leading to damages to the bearing.

- Tighten the oil sight glass into the oil filling hole (13) hand-tight.

11 Disassembly of the Bearing for Maintenance and Inspection

11.1 Tools and equipment

– Following tools and equipment are necessary:

- Allan key set
- Wrenching key set
- Open-jawed spanner set
- Feeler gauges (starting from 0,05 mm)
- Caliper gauge
- Emery paper, plain scraper
- Oil stone
- Eye bolts M 10
- Lifting equipment
- Permanent sealing compound
- Clean (close weave) rags
- Oil with the viscosity indicated (see bearing type plate)
- Detergents
- Liquid screw locking compound (e.g. LOCTITE 242)
- Liquid sealing compound and Teflon-tape.

11.2 Use of lifting equipment



Caution!

Before using the bearing lifting plate to transport or lift it, check if the screws at the split line are tight, otherwise the bottom half of the housing could become detached.

Before moving or lifting the bearing make sure the screw of the bearing lifting plate is tight. If the screw is not tight, the bearing or the top half of the bearing could become detached and drop down.

Before transport/lifting, check if the eye bolts mounted to bottom half of the housing are tight. Insecure eye bolts could result in the bottom half of the housing becoming loose.

Make sure that the eye bolts are not exposed to bending stress, otherwise the bolts could break.

Follow exactly the instructions for the use of lifting equipment.

Installation, Operation, Maintenance and Inspection

The instructions below refer to how you prepare correctly the bearing for the use of the lifting equipment.

Whole bearing

- Make sure the bolts at the split line are tight (3).

Bolt size	M 10
Torque [Nm] for yield tightening $\mu_{\text{total}} = 0,10$ (slightly oiled), torque factor 1,0	40
Torque [Nm] for torque controlled tightening with torque wrench $\mu_{\text{total}} = 0,10$ (slightly oiled), torque factor 1,6	32

- Mount the bearing lifting plate (5) to the tapped hole provided on the top half of the housing.
- Check that the lifting plate is tight.
- Connect the lifting equipment to the bearing lifting plate (5).

Top half of the housing

- Mount the bearing lifting plate (5) to the tapped hole provided on the top half of the housing.
- Check that the lifting plate is tight.
- Connect the lifting equipment to the bearing lifting plate (5).

Bottom half of the housing

- Screw two eye bolts M 10 tight into the cross-placed opposite tapped holes (12).
- Connect the lifting equipment to the eye bolts.

11.3 Preparation for disassembly

Attention !

Make sure that the work place and the parts to be assembled are clean. Contamination and damage to the bearing, especially of the working surfaces, have a negative influence on the operating quality and could lead to premature failure.

Attention !

Carry out all operations without making use of violence or force.

- Shut down the installation and secure it against unintended operation.
- Unscrew and remove all thermo sensors from the connection holes (14).
- Take all necessary measures to collect the lubricant .
- Remove the oil outlet plug (16). Drain off the lubricant.

Risk of pollution!

Please observe the instructions for the use of the lubricant. The manufacturer can provide information on waste oil disposal.

- Tighten the oil outlet plug (16) to the following torque rate.

Threads	G 1/2	G 1
Torque [Nm] for plugs with moulded on plastic seal	40	110
Torque [Nm] for plugs with elastic seal	60	130

- Open the assembly opening in the machine shield and disassemble the top half of the bearing.

11.4 Disassembly of the top half of the housing

- Unscrew and remove the four screws (3) at the split line and lift the top half of the housing (1) in vertical direction until the groove provided in the top half of the housing does not touch the seals any more.
- Lift the top half of the housing until the top flange is free.
- Continue to lift until you can move the top half of the housing over the shaft and shaft seals without touching them.

Generally it is not necessary to dismantle the baffle in order to dismantle the top half of the housing. If however, this is necessary, proceed as described in Chapter 11.5.

11.5 Disassembly of the baffle IP 55

- Loosen the screws (31) and then unscrew the top (28) and bottom (29) half of the baffle.

11.6 Disassembly of the inner and outer seals

- Pull the top half of the seal (23) apart about 20 mm. Tilt it backwards carefully, until the garter spring (27) springs off.



Caution!

During disassembly of the seals hold on tight to the tensioned garter spring (27), which otherwise could bounce back and lead to injury.

- Unhook the garter spring (27) .
- Take the bottom half of the seal (24) out of the guiding groove provided in the bottom half of the housing from the side with the anti-rotation pin.

11.7 Removing the top half of the shell

- Unscrew both screws at the split line (19) and in the case of insulated bearings (optional) disconnect the cable including washer underneath the cable connection.
- Lift the top half of the shell (17).

Attention!

Do not damage the thrust and journal working surfaces.

11.8. Dismantling of the loose oil ring

- Open both split lines of the loose oil ring (21) by untightening and taking out the screws (22). Separate both halves of the loose oil ring (21) carefully without using any tools or other devices.

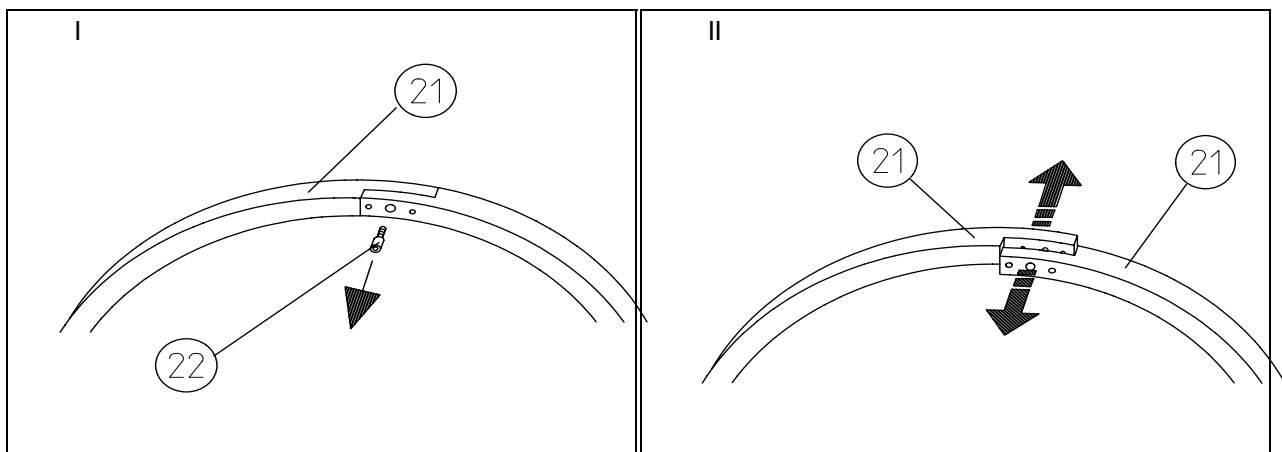

Illustration 3 Opening of the loose oil ring

To check the geometry of the loose oil ring put it together as follows:

- Press the positioning pin into the holes.
- Adjust both halves of the loose oil ring till the split lines match each other.
- Tighten the screws (22).

11.9 Removing the bottom half of the shell

Attention!

Make sure that all bearings mounted on a shaft line are opened. To open the bearings, loosen the screws at the split line of the housings.

Attention!

Do not touch the seal and working surfaces of the shaft with the lifting equipment.

- Lift the shaft up to the point where shaft and bottom half of the shell (18) do not touch each other any more. Prop the shaft against unintended movement.
- Turn the bottom half of the shell (18) out of the bottom half of the housing (2) and lift it away from the shaft.

Attention!

Do not damage the thrust and journal working surfaces.

12 Cleaning and Inspection of the Bearing

Attention!

Use only non-aggressive detergents, such as for instance:

- VALVOLINE 150.
- Alkaline cleaning compounds (pH-value 6 to 9, short reaction time).



Caution!

Please observe the instructions for the use of the detergents.

Attention!

Never use cleaning wool or loosely woven cloth. Residues of such materials left in the bearing could lead to excessive temperatures and therefore to damage to the bearing.

- Clean thoroughly, removing all traces of grease, oil, preservatives, etc. from the following parts:
 - the top half of the housing (1)
 - the bottom half of the housing (2)
 - top half of the shell (17)
 - bottom half of the shell (18)
 - seals
 - loose oil ring (21)
- Check visually the degree of wear of all bearing components. Make sure the shell shows a uniform, clear wear pattern, corresponding to the time it has been in use. The graph below provides information on the parts that might be replaced in case of wear. The right evaluation of the wear condition, especially of the working surfaces of the bearing shell, requires a lot of experience. If in doubt, replace the worn parts with new ones.

Bearing part	Wear condition	Maintenance measures
Shell	Scoring	Bearing temperature before inspection: <ul style="list-style-type: none"> • not increased - no new shell • increased - new shell
	White metal layer damaged	new shell
	Bow wave ridges	new shell
Shaft seal	Baffles broken or damaged	new shaft seal
Loose oil ring	Geometrical form (roundness, flatness) visibly changed; maintenance measures	new loose oil ring

- Check the positioning pin (8) and (optional for bearings with insulation) the insulating layer of the spherical seating (11) in the top (1) and bottom (2) half of the housing. If damaged, please contact the RENK sales office in charge.
- Check the condition of the half rings (32) in the top (1) and bottom (2) half of the housing. If damaged, please replace them.

13 Assembly of the Bearing after Inspection

To assemble the bearing after inspection please follow the instructions in Chapter 4 and 4.2.

14 Starting Operation after Inspection

- Mount the thermo sensor to the connection hole (14) for the temperature measurement of the journal part.
- Make sure connection the holes (14) are closed with thermo sensors and/or plugs.
- Tighten all plugs closing the connection holes (14), (15), (15) to the torque indicated below:

Threads	G 1/2	G 1
Torque [Nm] for plugs with moulded on plastic seal	40	110
Torque [Nm] for plugs with elastic seal	60	130

- Check if the top sight glass (15) is tight, the screws should be hand-tight.
- Carry out a visual check of the assembled bearing.
- Remove the oil sight glas from the oil filling hole (13).

Attention!
Make sure that no impurities get into the bearing.

- Fill the lubricant through the oil filling hole (13) up to the middle point of the oil sight glass (15). Use a lubricant with the viscosity indicated on the bearing type plate.
The oil level limits are as follows:

minimum oil level: **bottom of the oil sight glass**
maximum oil level: **top of the oil sight glass**

Attention!

- Not enough lubricant leads to temperature rises and thus to damages to the bearing.
- Too much lubricant leads to leakages. In the case of bearings with lubrication by loose oil ring too much lubricant could brake the oil rings considerably, thus leading to damages to the bearing.

- Tighten the oil sight glass into the oil filling hole (13) hand-tight.
- Check if the temperature monitoring equipment works.

The bearing is ready for operation.

- Close the assembly opening of the machine shield (with the thin metal plate)
- Supervise the bearing during the trial run (5 - 10 operating hours).
Pay special attention to:
 - the oil level
 - bearing temperature, temperature progression
 - sliding noises in the shaft seal area
 - tightness
 - occurrence of inadmissible vibrations.

Attention !

If the bearing temperature exceeds the calculated value by more than 15 K (see bearing computed calculations) stop the installation immediately. Carry out an inspection of the bearing.

15 Corrosion Protection for Extended Standstill Periods

To ensure corrosion protection of a bearing mounted to an installation proceed as follows:

- Dismantle the bearing (see Chapter 11).
- Clean the bearing (see Chapter 12).
- Paint or spray the top half of the shell (17), the bottom half of the shell (18), the loose oil ring (21), the shaft in the bearing area and both halves of the housing (1), (2) with Tectyl 511.
- Put a bag of dessicant (silicate gel) inside. The dessicant absorbs the humidity and prevents the formation of condensed water inside the bearing.
- Assemble the bearing (see Chapter 13).
- Close all openings with plugs.
- Seal the gap between housing and shaft with permanent, self-adhesive tape.
- Seal the hole of the pressure equalizing channel on the bottom half of the housing with permanent, self-adhesive tape.

In case the **standstill is longer than ½ year**:

- Dismantle the bearing (see Chapter 11).
- Repeat the preservation procedures.
- Put a new bag of dessicant (silicate gel) into the bearing.

In case the **standstill lasts more years**:

- Dismantle the bearing shells.
- Apply long term preservation to all bearing components and store them correspondingly.

16 Transport Protection

If you transport a machine equipped with slide bearings type ZM:

- Carry out the protection corrosion as described in Chapter 15. Apply enough lubricant to the working surfaces of the bearing.
- Secure the shaft against thrust and radial movement during the transport.

- Spherical seating** The spherical seating is a special feature enabling the alignment of the shell in the housing. The shell is seated and positioned on spherical segments. The advantages of the spherical seating are:
- ease of assembly
 - good heat transfer from the shell to the housing
 - suitable for applications with high thrust and journal loads.
- Floating labyrinth seal** The floating labyrinth seal is used as shaft seal in the case of slide bearings of type ZM operating under normal conditions. It prevents the lubricant and lubricant mist coming out of the bearing and the ingress of impurities. The floating labyrinth seal has a high capacity of resistance to wear. It is made of high-performance, high temperature resistant and electrically insulated plastic material. The floating labyrinth seal consists of two halves held together by a garter spring. Both ends of the garter spring are hooked together. In the case of slide bearings type ZM, the floating labyrinth seal is used as a standard seal, at both ends of the bearing. The seal groove allows for radial movement of up to 1 mm. The seal is thus insensitive to shaft radial displacement or deflection. The sealing effect is produced by the baffles wiping off the lubricant from the shaft. The lubricant flows back into the bearing via oil return opening.
- Machine seal** In the case of the flange mounted bearings, the machine seal reduces the influence of positive and negative pressure in the machine thus preventing leakages at the inner seal area. The space between the machine seal and the bearing housing must always be vented to atmospheric pressure. The size of the gap between shaft and machine seal influences the sealing effect.
- Baffle** Baffles are assembled externally in front of the shaft seals. The baffle, made of reinforced polyamide, protects the bearing from dust and water (protective system IP 55).



* 4 0 1 - 7 0 2 *