

**BALDOR • RELIANCE**

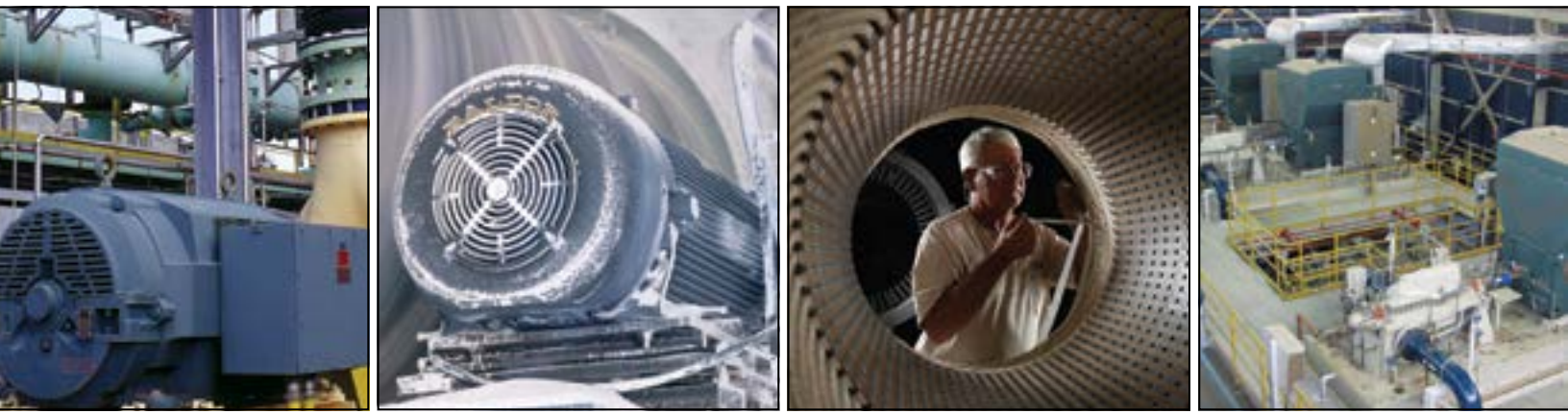

## **Large Frame AC Induction Motors**

**BALDOR**  
A MEMBER OF THE ABB GROUP

## Why Baldor?

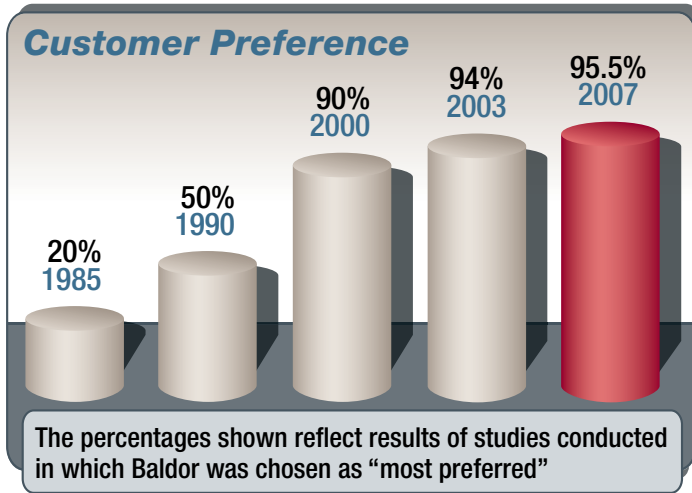

For nearly 100 years, Baldor has strived to provide customers with the best value and reliability in industrial electric motors. That kind of dedication results in satisfied customers and a strong preference for Baldor•Reliance motors, as the chart above shows. Here are just a few of the things Baldor does to earn such recognition:

**Baldor offers the industry's broadest line of stock products.** Save valuable time with just one call to Baldor. We offer more than 10,000 stock motors, drives and gearboxes.

**Energy-efficiency leader.** Baldor began lowering the energy consumption of our motors in the 1920's, long before others were even talking about it. Today, Baldor's expansive line of Premium Efficiency motors extends from 1 through 15,000 Hp. Baldor's motors offer customers the highest overall efficiency levels in the industry, including Baldor•Reliance Super-E® (1 through 500 Hp) motors that exceed NEMA Premium® efficiencies.



**Baldor products are available at more locations than any other brand.** Our 35 district offices across North America and hundreds of ABB offices around the world, offer immediate availability of Baldor products and support to thousands of customers.

**Continuous innovation to improve reliability.** Baldor leads the motor industry in applying new technologies to improve motor reliability. Recent improvements to the line of Severe Duty motors are further proof that Baldor is the leader in motors for process industry applications. These improvements are explained in detail in the following pages.

### Industry's shortest lead times/Flexible manufacturing.

Baldor has the industry's shortest lead times on custom Large AC Motors. Our unique LEAN FLEX FLOW™

manufacturing process lets us produce any order in any quantity, quickly and efficiently.



**Industry's best access to information.** Only Baldor offers customers so many choices for product information with a wide variety of catalogs and product brochures, the Baldor Web site at [www.baldor.com](http://www.baldor.com), or you may talk to a Baldor customer service person at one of our sales offices.

## Table of Contents

Subject (related to Large AC Motors)	Page
Baldor's Value Proposition _____	1
Product Exploded-View _____	2-3
Energy Efficiency _____	4
Motors for Stock _____	5
Design Characteristics _____	6
Test and Verify _____	7
Insulation Systems for Large AC Motors _____	8
API 547 and 541 _____	10
Product Capabilities _____	14
2-Pole AC Induction Motors _____	16
Vertical AC Motors _____	18
Extra-Large AC and Custom Motors _____	20
Replacement and Specialty Custom Engineered Motors _____	22
Open Drip Proof and WPI Motors _____	24
WPII Motors _____	26
TEFC Motors _____	28
TEAAC Motors _____	30
Explosion-Proof Motors _____	32
Typical Performance Data _____	33-38
Variable Speed Superiority _____	39
Dimension Drawings _____	40-52
Connection Diagrams _____	Inside Back Cover

## Baldor•Reliance Large Frame AC Motors... value customers expect!

Baldor•Reliance motors provide industry leading value largely because of their 100+ year heritage of exceeding customer expectations. This includes providing Large AC Motors to customers for more than 50 years and in doing so, gaining a deep understanding of a broad range of industries and critical applications. The Baldor•Reliance product legacy extends from a wide range of general purpose motors to motors designed for the most hazardous and critical application extremes. In addition to Baldor's being the most preferred supplier of industrial motors in North America, Baldor•Reliance is also the most specified motor in the Petrochemical industry and is the first motor to be certified under the API 547 monogram program.

Nobody knows more about their process than the customer. That is why Baldor employs dedicated industry teams whose sole purpose is working directly with Industry users, consultants and OEMs. These experienced Baldor engineers are dedicated to understanding the customer's specific performance requirements and translating this into solutions and products that exceed customer expectations.

### **Dependability is built into every Baldor•Reliance motor:**

A passion for reliability continues to drive Baldor's design process. The Baldor•Reliance reputation for robust motor construction is built into design features that include:

- Aluminum rotor die casting machines designed to eliminate casting porosity for superior rotor bar and end ring integrity is standard on most motors
- Copper bar rotors with a free floating squirrel cage that will not fail from expansion and contraction can be supplied if required by motor design or request
- The Baldor•Reliance flagship, Enduraseal insulation system, where every winding is given an immersion test per NEMA MG1, Part 20.18.1 (SolidCure insulation system is standard)
- Mechanically, Baldor provides a superior patented PLS bearing lubrication system that positively lubricates when the motor is in any position and has multiple grease relief locations preventing over-greasing which leads to a majority of antifriction bearing failures.



*Baldor's new generation of open motors have become an industry leader in weather protected motor designs.*

### **Performance every time:**

Because interaction with the power grid is uniquely important when applying Large AC Motors, Baldor's advanced development center has conceived designs that reduce inrush current and locked rotor KVA while assuring high power factor. For larger motors and more critical applications, it becomes even more important to understand the load and power grid with each new motor design. Here Baldor engineers develop standard catalog and custom motor designs that consider load inertia, load curves, starting frequency and starting method. The outcome is a Baldor•Reliance motor with performance that will match the customer's specific needs and provide years of dependable service in the most unique critical service applications.

### **High Efficiency for low cost of operation:**

While designing for performance, Baldor knows that electricity consumption represents the primary ownership cost of an electric motor. Baldor takes great pride in standard designs that typically exceed industry norms for custom designed high efficiency motors. This did not just happen. Baldor's high efficiency designs are the result of engineering excellence, years of field experience, R&D testing and acclaimed dedication to leadership in energy efficiency.

## Baldor Large AC Motors: Built for Reliable Performance

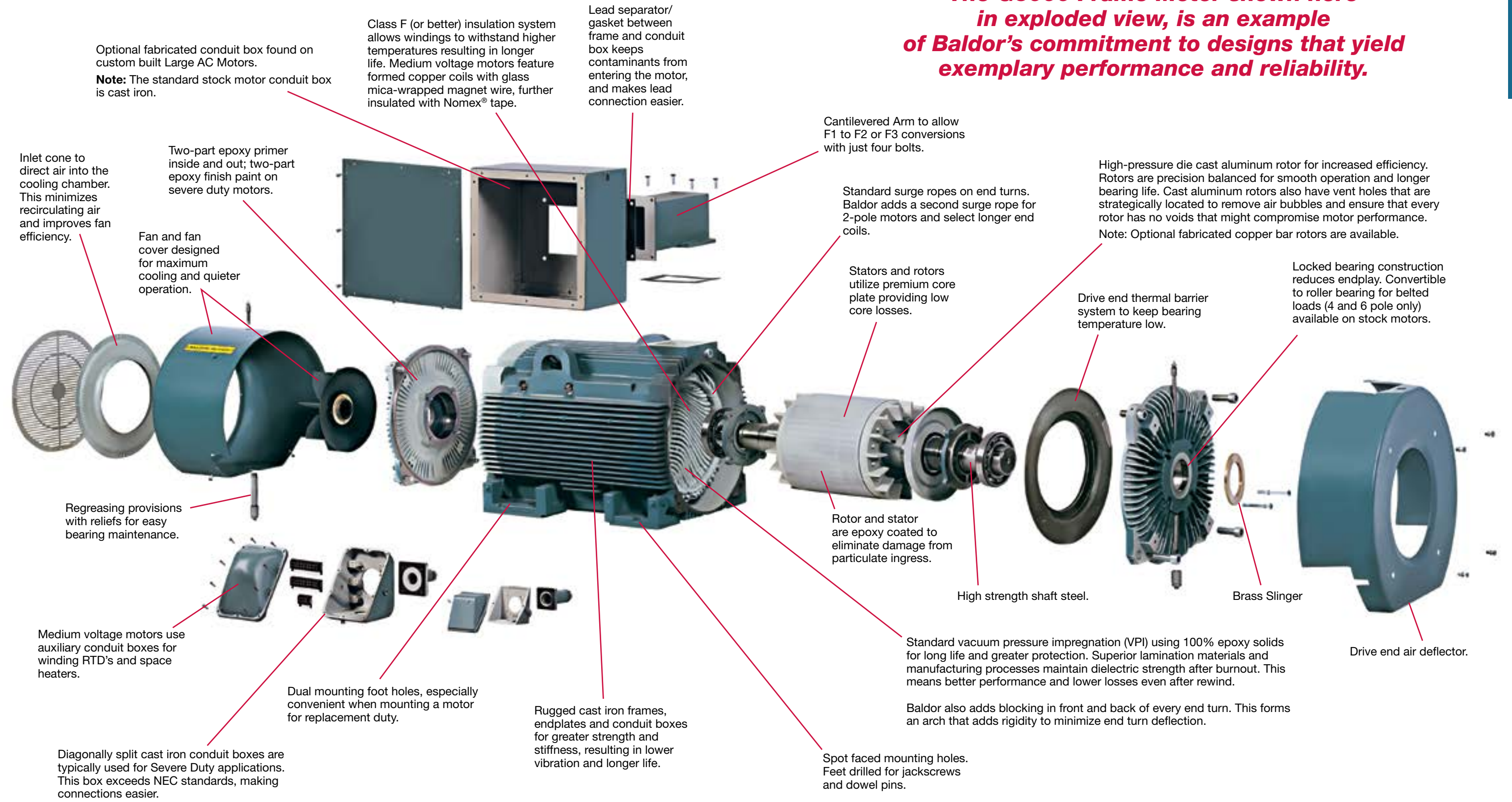

Optional fabricated conduit box found on custom built Large AC Motors.  
**Note:** The standard stock motor conduit box is cast iron.

Class F (or better) insulation system allows windings to withstand higher temperatures resulting in longer life. Medium voltage motors feature formed copper coils with glass mica-wrapped magnet wire, further insulated with Nomex® tape.

Lead separator/gasket between frame and conduit box keeps contaminants from entering the motor, and makes lead connection easier.

Inlet cone to direct air into the cooling chamber. This minimizes recirculating air and improves fan efficiency.

Two-part epoxy primer inside and out; two-part epoxy finish paint on severe duty motors.

Fan and fan cover designed for maximum cooling and quieter operation.

Cantilevered Arm to allow F1 to F2 or F3 conversions with just four bolts.

Standard surge ropes on end turns. Baldor adds a second surge rope for 2-pole motors and select longer end coils.

High-pressure die cast aluminum rotor for increased efficiency. Rotors are precision balanced for smooth operation and longer bearing life. Cast aluminum rotors also have vent holes that are strategically located to remove air bubbles and ensure that every rotor has no voids that might compromise motor performance.  
**Note:** Optional fabricated copper bar rotors are available.

Stators and rotors utilize premium core plate providing low core losses.

Drive end thermal barrier system to keep bearing temperature low.

Locked bearing construction reduces endplay. Convertible to roller bearing for belted loads (4 and 6 pole only) available on stock motors.

Regreasing provisions with reliefs for easy bearing maintenance.

Rotor and stator are epoxy coated to eliminate damage from particulate ingress.

High strength shaft steel.

Brass Slinger

Drive end air deflector.

Medium voltage motors use auxiliary conduit boxes for winding RTD's and space heaters.

Standard vacuum pressure impregnation (VPI) using 100% epoxy solids for long life and greater protection. Superior lamination materials and manufacturing processes maintain dielectric strength after burnout. This means better performance and lower losses even after rewind.

Baldor also adds blocking in front and back of every end turn. This forms an arch that adds rigidity to minimize end turn deflection.

Dual mounting foot holes, especially convenient when mounting a motor for replacement duty.

Rugged cast iron frames, endplates and conduit boxes for greater strength and stiffness, resulting in lower vibration and longer life.

Spot faced mounting holes. Feet drilled for jackscrews and dowel pins.

Diagonally split cast iron conduit boxes are typically used for Severe Duty applications. This box exceeds NEC standards, making connections easier.

# Big Motors can mean Big Savings by understanding how to make Energy Efficiency work for you

## Why all the talk about Motors and Energy Efficiency?

Electric motor-driven systems used in industrial processes consume about 63% of all electricity used in the U.S. industrial sector according to a U.S. Department of Energy report. In a later report the D.O.E. also said that “best practices” have shown an average energy savings of 33% when these practices include motor and motor systems upgrades, including the use of adjustable speed drives.

## Thinking beyond the Initial Purchase Price

The D.O.E. has shown the average motor will operate for 28 years. So just as you would with any long term investment, it is important to expand your focus from the initial purchase price to the life cycle cost of that investment.

The pie chart to the right shows elements of the typical life cycle cost of a motor operating in a continuous duty mode for 20 years. As you can see the original purchase price is almost insignificant compared to what it will cost to operate the motor over that motors life span.

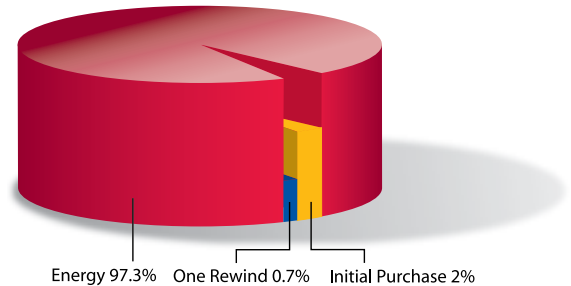

## Understanding your Total Investment

To begin understanding your total investment you need to know the cost of energy consumed during the anticipated life of the motor. The chart below is an example of how these costs are determined and the positive impact of selecting Premium Efficiency motors whenever buying decisions are made.

The formula typically used to calculate energy consumption is:

$$\text{Total Energy Cost} = \text{Input kW power to the Motor} \times \text{Hours of Operation} \times \text{Cost of Power}$$

For this example we will assume:

- You are replacing an existing 1000 Hp motor
- The motor operates continuously 50 weeks/year
- The existing motor efficiency is 93.7%
- The replacement motor efficiency is 95.0%
- Energy cost is \$0.075/KW hr

Using this formula, savings associated with buying a Premium Efficiency motor will be:

\$7,158 each year  
\$143,160 after 20 years

Depending on normal market variables such as features and other options, the 1000 HP motor used in this example would sell for about 10% of its annual energy costs. So when you compare the original purchase price to the cost of energy required to operate the motor, it is easy to understand why careful motor selection from the start is so important. And when you do select a premium efficiency motor you will consume less energy, reduce operating costs and improve your bottom line over the operating life of that motor.

Whether you are buying motors as part of a new capital project or if you are just thinking of replacing an existing motor as in the example above, making the best choice of available options can be intimidating. To help with these decisions, Baldor has developed an innovative software program (“BE\$T”) that will help you maximize motor efficiency and minimize electricity use. For more information about the BE\$T program you are invited to contact your local Baldor office or look us up on [www.baldor.com](http://www.baldor.com).

## Large AC Motors...In Stock!

Baldor stocks a family of Premium Efficient Motors specifically designed for a variety of applications in a wide spectrum of industries. This family of Low and Medium Voltage 2, 4, and 6 Pole TEFC motors extends from 250 Hp through 1250 Hp. Baldor•Reliance motors for stock are a minimum 95% efficient including many ratings that exceed 96%. All these motors built for stock are Class B rise at 1.0 Service Factor and are well suited to drive routine pump, fan and compressor loads as well as driving more critical service loads and operating in severe duty environments. Standard features include minimum 95% efficiency, Class B Rise at 1.0 Service Factor, Ultra-Precision balance to 0.10 inches/second, winding RTD's, CSA and Div 2 Class I Groups C & D Hazardous Location certifications.

Now customers in need of same day deliveries for General Purpose and Special Purpose applications have access to a wide range of Large AC Motors that are stocked in Baldor's District Offices and Fort Smith Distribution Center.

### Shown below is a summary of Baldor's Large AC Motors in Stock:

#### 2300/4000 V

Hp	Poles	Enclosure	Bearing Type	Frame	Catalog #
200	2	TEFC	Ball	G449TS	ECP44202T-2340
	4	TEFC	Ball	G449T	ECP44204T-2340
250	2	TEFC	Ball	G5008S	ECP50252S-2340
	4	TEFC	Ball	G5008L	ECP50254L-2340
	6	TEFC	Roller	G5010LY	ECP50256LR-2340
300	2	TEFC	Ball	G5008S	ECP50302S-2340
	4	TEFC	Ball	G5008L	ECP50304L-2340
	6	TEFC	Roller	G5010LY	ECP50306LR-2340
350	4	TEFC	Ball	G5008L	ECP50354L-2340
	6	TEFC	Roller	G5012LY	ECP50356LR-2340
400	2	TEFC	Ball	G5010S	ECP50402S-2340
	4	TEFC	Ball	G5008L	ECP50404L-2340
	4	TEFC	Ball	G5008S	ECP50404S-2340
	6	TEFC	Roller	G5012LY	ECP50406LR-2340
450	2	TEFC	Ball	G5010S	ECP50452S-2340
	4	TEFC	Ball	G5010L	ECP50454L-2340
500	2	TEFC	Ball	G5010S	ECP50502S-2340
	4	TEFC	Ball	G5010L	ECP50504L-2340
	6	TEFC	Roller	G5012LY	ECP50506LR-2340
600	2	TEFC	Ball	G5010S	ECP50602S-2340
	4	TEFC	Ball	G5012L	ECP50604L-2340
700	4	TEFC	Ball	G5012L	ECP50704L-2340
800	4	TEFC	Ball	G5012S	ECP50804S-2340
	2	WPIL	Sleeve	05810S	EM251252S-2340
1250	4	WPIL	Ball	05810S	EM251254S-2340

**Note:** For inverter applications, contact your local Baldor sales office.

\* This rating is precision balanced to 0.12 in/sec velocity.

#### 460 V

Hp	Poles	Enclosure	Bearing Type	Frame	Catalog #
400	2	TEFC	Ball	G5010S**	ECP50402S-4
500	2	TEFC	Ball	G5010S**	ECP50502S-4
	4	TEFC	Ball	G5010Z**	ECP50504L-4
600	2	TEFC	Ball	G5810S**	ECP50602S-4
700	2	TEFC	Ball	G5810S**	ECP58702S-4
800	2	TEFC	Ball	G5810S**	ECP58802S-4

\*\* This rating is suitable for use in inverter applications.



*This Baldor•Reliance motor powers fans for a "bio-scrubber" air filtering system. This unique system is part of a fiber board mill located in Columbia Falls, Montana where filter beds use bacteria to remove impurities and reduce emissions.*

# Baldor•Reliance Motors

## Electrical Design Characteristics

Specification	Standard Design	Typical Modifications
Voltage, Frequency	460, 480, 575, 690, 2300, 4000, 6600, 13,200 volts @ 60 Hz 380, 415, 690, 3000, 3300, 6000, 11,000 volts @ 50 Hz	Non-standard low, medium and high voltages
Service Factor	1.0 SF @ 80 degrees C by resistance	1.15 and higher service factors
Ratings	NEMA design B (torque type)	NEMA design C & D (torque type); low inrush current
Ambient Temperature	40 degrees C	Higher or lower temperatures
Windings	>1000V...Form wound copper, Class F 155° C, mica Nomex® tape, 100% solvent less epoxy impregnated (optional on <1000V) <1000V...Random wound copper coils with dip & bake	Sealed (EnduraSeal) windings with two VPI cycles and immersion tested per NEMA MG 1, Part 20, additional VPI cycles (3 max), surge withstand
Winding Insulation Class	Class F, non-hygroscopic epoxy resins	Class H high temperature
End Turn Bracing (medium & high voltage)	Layered tape, rope(s) or steel bracing ring (each of which is lashed to every coil)	Additional rope or steel bracing for high vibration applications
Stator Component System	Nomex® Class H slot liner, woven glass Class H phase insulation, epoxy impregnated blocking felt between coils	Complete winding system Surge Withstand Capability (standard for Inverter Duty applications)
Lead System	Vulcanized ethylene propylene or silicon (oil resistant, class H) lead material, ring type lead lugs	Oil resistant silicon material, compression lead lugs, quick disconnects
Thermal Protection	Winding RTD's with auxiliary conduit box, 100 ohm, 3 wire platinum (only standard on Catalog Stock Motors - not standard on custom motors)	Other RTD types, thermocouples, thermostats, NEMA 4X auxiliary conduit box
Testing	Balance, winding resistance, no-load amps, power & nominal speed, locked rotor amps & torque, vibration, hi-pot	Complete with dynamometer, API 541, noise, efficiency per IEEE 112 methods, motor/inverter, bearing housing natural frequency
Third Party Approvals	CSA recognized components (standard on Catalog Stock Motors – optional on custom motors)	Hazardous locations (UL, CSA, NEC, CEC, IEC, ATEX)

## Mechanical Design Characteristics

Specification	Standard Design	Typical Modifications
Frame Dimensions	NEMA compliant	IEC compliant (per applicable sections of IEC 60034 & 60072, TEFC frames Only)
Foot Mounting Holes	Multiple holes on specified frames	Special spot facing, dowel pins, jack screws
Nameplate	Stainless steel plate and rivets, NEMA compliant	Special markings, non English, CSA, third party labels, auxiliary plates for motor characteristics and customer data
Slinger & Seals	Labyrinth seals, Forsheda® style or brass slingers on WPI, WP11 and TEFC when specified with severe duty and other critical service applications	Inpro/Seal® (rated for IP 54, 55, 56) and Taconite seals
Hardware	Grade 5, U.S. Standard, zinc dichromate or cadmium plated steel	AISI Series 300 Stainless Steel
Grounding	Ground lug (silicon-bronze, stud type) in conduit box is standard for severe duty motors, frame ground pad	Conduit box and frame (except for explosion proof motors) grounding pad, servit post, ground lugs, bearing grounding, shaft grounding
External Cooling Fan	Non sparking polyurethane	Steel, bronze, aluminum and arctic duty available on some TEFC and TEAAC designs,
Internal Cooling Fan	Integrally designed with cast aluminum rotors, shaft mounted steel on fabricated rotors (some exceptions on larger frames)	Bronze, aluminum and arctic duty available on ODP, WP11, TEAAC and TEWAC enclosures
Balance	Exceeds NEMA MG1 (4 pole @ 0.15 in/sec bracket velocity & 2.8 mils shaft displacement)	Precision Balance...4 pole @ 0.10 in/sec & 2.0 mils Ultra-Precision Balance...4 pole @ 0.10 in/sec & 1.5 mils
Shaft	Cold rolled steel	Forged steel, special length and diameter, tapered or threaded, double extension, magnetic center indicator
Paint	Surface preparation (SSPC-SP-6), primer (SSPC-SP-1), top coat (Alkyd Enamel)	Standard Plus (includes solvent based epoxy top coat), APEX (includes epoxy intermediate coat and 2-part polyurethane top coat)
Bearings	Anti friction (grease lubricated), sleeve (oil ring or flood lubricated)	Drive end roller, electrically isolated bearings, bearing temperature RTD's, sleeve bearings can be substituted where anti friction bearings are standard (except 440 frames)
Noise	Varies with design, complies with NEMA MG 1	Low noise options on both enclosed and open frames

**Note:** For more information about available modifications, contact your local Baldor office.

## Test and Verify

Baldor employs state of the art design tools, advanced materials and dependable manufacturing methods to achieve a precise combination of desired performance characteristics. Additionally, both individual components and assembled motors are rigorously tested and proven to meet the specified requirements.

Materials and components are tested before assembly to make certain material specifications are being met by suppliers. During the manufacturing process, sub assemblies such as stator and core are tested prior to final assembly. After final assembly every motor gets a Routine Test.

In addition to the requirements of NEMA MG 1-2011-20.16.2, the following tests/checks are also conducted on each assembled motor:

### Routine Test

- Measurement of winding resistance
- No-load readings of current, power and nominal speed at rated voltage and frequency
- High potential test in accordance with MG 1-20.48
- Three phase locked rotor current and torque
- Vibration check in accordance with MG 1-20.54

The optional Complete Test consists of the following:

### Complete Test

- Routine test
- Full load temperature test (loading by dynamometer)
- Full load speed (% slip)
- Check of current balance
- Full load current
- Pull up (derived), breakdown and full load torque
- Efficiency and power factor vs. load
- Dynamometer heat run to determine full load or service factor at temperature rise
- Dynamometer measured efficiency in accordance with IEEE 112 method B

The complete list of optional Baldor•Reliance test capabilities is vast. Some of the more common tests performed by Baldor are; API 541 Routine Test, Noise, Polarization Index and No Load Vibration Tests.

Of particular interest, every Enduraseal® stator up to 7000 volts passes a sealed winding conformance test (immersion test) in accordance with NEMA MG 1-20.18.1. This test consists of submerging the completed stator in a tank of water containing a wetting agent. While submerged, the stator is given a 10 minute polarization index test at 500 volts DC, and a high potential test at 1.15 times the rated line to line RMS voltage for one minute.

Testing disciplines described here verify design integrity and manufacturing consistency. This brings the Baldor quality story full circle and ensures performance predictability on every Baldor customer application.

## Insulation Systems for Large AC Motors

For motors utilizing form wound construction for the stator coils there are (3) options available for the type of insulation system used.

**SolidCure** - This is the standard insulation system and is the foundation for all Baldor•Reliance medium voltage motors, and when form wound coils are specified for low voltage motors. It is a Class F rated system using Class H materials. Coils are wrapped with layers of mica impregnated nomex tape. Stators receive additional bracing in the coil-heads, and the whole stator is processed in 100% solid epoxy resin through a Vacuum Pressure Impregnation (VPI) cycle. The processed stator is then cured while slowly rolling (rotating) horizontally in an oven. The finished stator winding has a solid void-free insulation system that provides superior heat transfer and corona avoidance. It has been validated fully to IEEE 429 laboratory proof testing including thermal life and chemical resistance tests, and through many years of successful field experience.

Note: Rotate Cure Process only available on Kings Mountain and Stratford manufactured motors.

**SolidSeal** - The SolidSeal Insulation system uses two VPI Cycles with additional sealing material. This insulation system is capable of passing the IEEE 429 Water Immersion Test.

**Enduraseal** - The Enduraseal insulation system meets the needs of both today's and tomorrow's tough motor applications. In over forty years of field use, under conditions ranging from dry, dusty desert environments to damp, corrosive chemical plant atmospheres, Enduraseal has proved its reliability time and time again. This is a superior system which is achieved by using Nomex M Tape and an Epoxy Resin.

The rotate cure prevents the Resin from flowing out of the stator.

- Outstanding moisture, chemical, and abrasion resistance
- Superior electrical, thermal, and mechanical characteristics for longer coil life
- Every motor 6900V and below receives an immersion test per IEEE 429. Higher voltages are tested per 429 with underwater megger only.
- Designed for both inverter duty and sine wave power
- Specially engineered for medium and high voltage systems up to 13.8 kV

**The Enduraseal Stator** - A complete Enduraseal insulated stator provides maximum protection from extreme environmental and electrical conditions.

**Coil Head Bracing and Leads** - After all coils have been inserted into the stator slots, and the topsticks (polyester glass laminate) are in place, the coils are lashed to a steel ring(s) or epoxy-impregnated woven glass rope. The heads are blocked with a process patented by Reliance® using Nomex M or Dacron mat and polyester laminate. This ensures negligible coil head movement during severe applications requiring plug reversals, across-the-line starts, etc. Leads are EPDM standard, Class F cable with a voltage rating to match the insulation system. (Alternate lead cable types, including class H, are available for special applications or by request.)

**Sealing Process** - Every wound stator goes through Vacuum Pressure Impregnation (VPI), with oven-bake cycles after each VPI. This process transforms the coils into a solid, rugged mass, free of voids and with excellent heat-dissipating ability. The exclusive 100% epoxy solids formulation was developed by Baldor•Reliance for maximum penetration and homogenous fill, as well as superior environmental resistance. Complete in-process and proof testing, including surge, dissipation, and dielectric, are provided to verify the integrity of the system.

**Immersion Test** - After the VPI processes and oven curing, every motor is individually tested in accordance with the underwater test procedures of NEMA MG 1-20.49.1, an evaluation of sealed insulation systems. Every Enduraseal insulated stator must pass this test before being released for assembly.

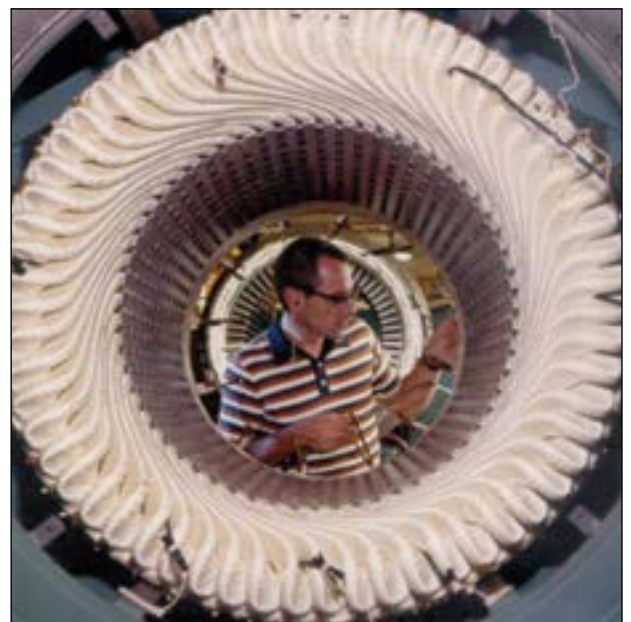
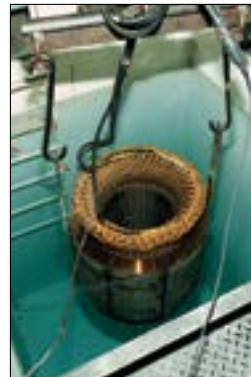

## Insulation Systems

### The Enduraseal Coil

Coils are engineered specifically for the required voltage and application.

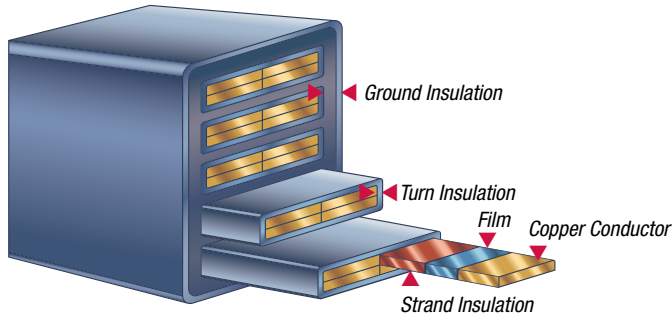

**Coil Wire** - All coils are manufactured with 100% copper wire. The turn insulation is designed to meet NEMA MG1 20.87 surge voltage resistance criteria.

#### Turn insulation guidelines:

0-25 Volts (Turn-to-Turn): Polyester Amide Imide Film

25-50 Volts (Turn-to-Turn): Film and Dacron® Glass Covering

50-100 Volts (Turn-to-Turn): Film and Mica Tape

**Standard Low Voltage** - The standard winding and insulation system for most Baldor•Reliance Large AC low voltage motor (less than 1000 hp and 1000V) utilizes a random wound design. This time proven system uses 100% solids epoxy resin and is processed using:

- **RSN** - A combination of Vacuum Impregnation (no pressure) and/or more Dip and Bake cycles.

**Ground Insulation** - The heart of any insulation system is the ground insulation. Enduraseal uses multiple layers of Nomex® M (mica tape), engineered for specific voltage requirements. This material gives the maximum insulation strength in the least amount of space, allowing more room in the slot for the copper in today's high-efficiency motors. Nomex M also provides excellent corona resistance, making it ideal for high-voltage applications.

**Armor Tape** - An outer layer of glass armor tape provides additional protection from abrasives such as fly ash and rock dust. After final taping, all coils are surge-tested per the IEEE 522 test procedure to assure there are no turn-to-turn shorts.

**Enhanced Corona Protection** - Corona resistance is achieved by utilizing conductive and semi-conductive tapes. This protection is standard on all 13.8 kV systems. Conductive tapes are used on all motors greater than 5 kV.

**Insulation System** - The Enduraseal system has been proven in various laboratory tests with the following results:

- **Chemical Resistance** - Sealed coils were immersed in solutions of the following chemicals for 500 hours with no degradation: Sulfuric acid, Black liquor, Hydrochloric acid, Sodium chloride, Sodium hydroxide and Detergent.
- **Thermal Evaluation**
  - **Motorette Testing** - The system was tested per IEEE 429 test procedure for evaluation of sealed insulation systems.
  - **Thermal Cycling:** 180°C, 200°C, 220°C
  - **Mechanical Stress:** 8 mils deflection
  - **Humidity:** 100%, 48 hours, proof tested wet
  - **Water Immersion:** Proof tested while immersed in water @ 1.15 x rated voltage
  - **Results:** Meets Class H requirements



Continuous rotation of stator during the curing process.

#### Dielectric Strength

Breakdown voltage tests were conducted to evaluate the ability of the Enduraseal system when subjected to various voltages.

**Test Procedure:** ASTM D149, Step by step

- 500 Volt base
- Steps of 2 kV/Min.

**Results:** The minimum breakdown voltage for the Enduraseal system was established to be ten times the operating voltage.

**Abrasion Resistance Test:** The Enduraseal system was subjected to high-velocity abrasive particles.

**Results:** The Enduraseal system showed greater abrasion resistance than other VPI systems evaluated.

# API 547 and API 541 for Large AC Motors

## API 547

Users in the Petroleum and Chemical industries sometimes prefer general purpose motors that are easy to specify and still have base features that ensure safe and reliable operation in critical service applications. In response to this need the American Petroleum Institute developed the API 547 standards for form wound induction motors used for general purpose petroleum, chemical, and other industrial severe duty applications.

API 547 compliant motors are:

- Rated 250 Hp – 3000 Hp with TEFC and WP II enclosures for 4, 6 and 8-pole machines
- 250 Hp to 800 Hp for 2-pole TEFC machines
- 250 Hp to 1250 Hp for 2-pole WP II machines
- Engineered in accordance with American Petroleum Institute standards
- Ideally suited for many centrifugal pump, fan and compressor applications having inertia values within those listed in NEMA MG1, Part 20

API 547 motors are specified with standard selections for all requisite motor features and accessories, so purchaser data sheets are not required in the standards. When the purchaser does require data sheets only the following minimum data is typically requested:

- Hp
- Enclosure – TEFC or WP II
- RPM
- Voltage/Frequency
- Area classification if applicable

As mentioned earlier, the Baldor•Reliance API 547 motor is the first motor of any kind to receive the API Monogram. As an API licensee Baldor has once again demonstrated a legacy of employing state of the art quality systems that enable Baldor to provide general purpose motors that are not only safe, but motors that stand up to the most rigorous of critical service applications. In order to gain the API Monogram recognition, Baldor has demonstrated and documented an infrastructure, responsibilities, control processes and resources needed to establish and maintain this quality tradition.

**Designs are available for 2-pole and 4-pole ratings noted here:**

3600 RPM – 60 Hz			1800 RPM – 60 Hz		
Hp	TEFC Frame	WPII Frame	Hp	TEFC Frame	WPII Frame
250	G5008	E5010	250	G5008	E5006
300	G5008	E5010	300	G5008	E5006
350	G5008	E5010	350	G5008	E5006
400	G5010	E5808	400	G5010	E5008
450	G5010	E5808	450	G5010	E5008
500	G5010	E5808	500	G5010	E5010
600	G5012/G5810	E5808	600	G5012	E5010
700	G5012/G5810	E5808	700	G5012	E5012
800	G5012/G5810	E5810	800	G5012	E5012
900	—	E5810	900	G5012	E5808
1000	—	E5810	1000	G500M	E5810
1250	—	E5810	1250	G500M	E5810
1500	—	—	1500	G500M	E5812
1750	—	—	1750	G500M	E5812
2000	—	—	2000	G500M	E5812
2250	—	—	2250	G500M	6811
2500	—	—	2500	Custom	6811
2750	—	—	2750	Custom	6813
3000	—	—	3000	Custom	6813

\* May require Flood Lube \*\* TEAAC Enclosure

Contact a Baldor office for latest capabilities.

# API 547 and API 541 for Large AC Motors

## API 541 (4th Edition)

When users in the Petroleum and Chemical industries want special purpose motors with uniquely defined features and accessories they turn to the API 541 standards. These standards apply to form wound induction motors rated 500 Hp and larger and used in critical service applications found in severe and abnormally hostile environments.

Unlike the counterpart API 547 standards, the API 541 standards do require comprehensive data sheets from the purchaser in order to delineate the users specific needs. Given the very critical nature of these applications, in addition to the basic data required for API 547 motors the API 541 data sheets cover an extensive range of application, enclosure, load, testing and accessory features. It's worth noting that API 541 data sheets include detailed purchaser specifications and supplier data that either the purchaser or supplier can use.

Baldor engineers participated in both the API 541 and API 547 working group committees and today Baldor•Reliance motors are the preferred choice of users in the Petro Chemical industry.

In an effort to bring more consistency and reliability to Petrochemical applications, in September of 2003 the API 541 authors made some notable changes to the standards. Today the API 541 fourth edition includes the following:

- Applies to larger motors 500 Hp and above, to avoid conflict with IEEE 841 standards
- Concentrates on special purpose "custom" motors and critical service applications
- Addresses applications with variable frequency drives such as requiring the motor to operate below 80 degrees C temperature rise at any speed when driving a variable torque load
- Includes expanded appendices that provide in-depth discussion of complicated issues
- Provides expanded use of Mechanical and Electrical Standard paragraphs
- Establishes a sound pressure limit that is compliant with OSHA requirements
- Requires motors to be operated at 1.0 service factor forcing the selection of higher ratings when overload capability is required
- Tightens design parameters that define resonant frequency limits
- Relies heavily on data sheets to document complete application details that will ensure the motor and drive (where applicable) are designed and built in a manner that will yield the intended performance

API standards were developed by Petroleum and Chemical users. However, in recognizing the importance of the design itself and the credibility of the Standards, many non-API industry users have applied API 541 and API 547 Standards to their own applications in order to achieve process integrity. This has proven to be especially true when larger AC motors are coping with unique load conditions found in reciprocating compressors, vertical turbine pumps, induction generators, axial thrust loads and variable frequency drives.

**To help the reader differentiate between API 547 and API 541 motors, the following charts are provided:**

Scope	API 547	API 541
Power	250 Hp - 3000 Hp	500 Hp and larger
Voltage	Any through 13.2 kV 50 & 60 Hz	Any through 13.2 kV 50 & 60 Hz
Speed	2 pole thru 8 pole	Any speed and no. of poles, or AFD controls
Site	Severe Duty applications	Severe and abnormally hostile environments
Enclosures	TEFC and WPIL	Any enclosure
Bearings	Hydrodynamic (sleeve) bearings default	Hydrodynamic (sleeve) bearings default
Applications	General Purpose for centrifugal loads	Critical Service for any load condition
Mounting	Horizontal	Horizontal and Vertical
Rotor	Aluminum thru 1000 Hp, Fabricated Copper above 1000 Hp	Fabricated Copper default, Aluminum only on approval
Shaft	<i>Forged shafts required on:</i> Two pole motors Flexible shaft motors	<i>Forged shafts required on:</i> Shafts larger than 8" Two pole motors > 1000 Hp Flexible shaft motors Motors driving reciprocating loads Motors using tapered hydraulic fit couplings
Critical Speed	Does not differentiate between a well damped resonance and lateral critical speed	Allows for a well damped resonance within the 15% separation margin

## API 541 AC Motors

*The API 541 motor incorporates the proven performance features found in all Baldor•Reliance Large AC motors.*



### **Precision Bearing Alignment**

Bearing alignment is critical to the performance and reliability of a motor. Baldor•Reliance bearing brackets are fabricated steel with machined rabbet fits to ensure accurate alignment between the rotor and stator. Bearings are precision-bored split sleeve with oil ring lubrication (some ratings may require flood lube). Alignment is controlled through design of fits and support elements. Non-sparking shaft seals, pressure-balanced by a purged arrangement, where applicable, are also provided on all API Motors.

### **Rigid Frame**

Baldor•Reliance utilizes heavy fabricated steel frame construction. These frames are designed, modeled and built to assure both lateral and torsional rigidity.

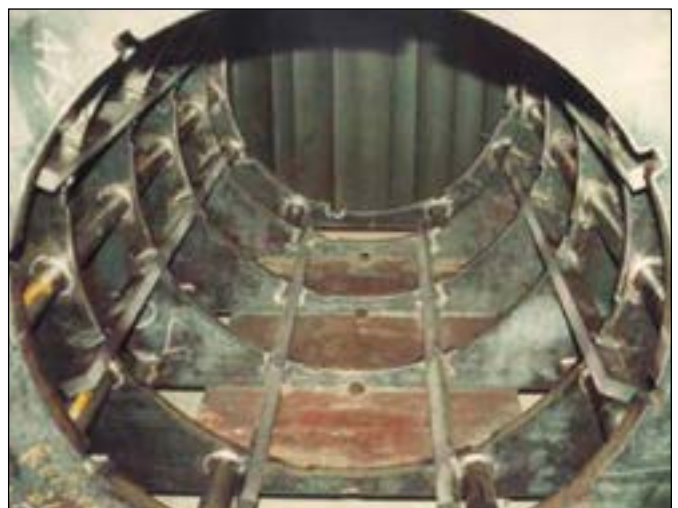
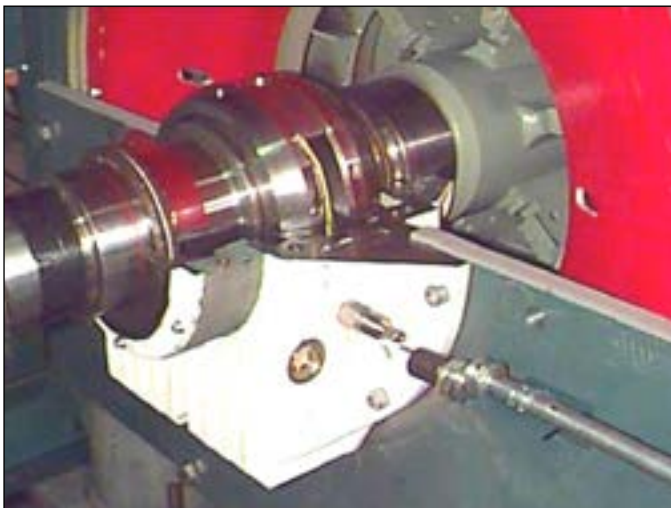

## API 541 AC Motors

### Proven Enduraseal Insulation

The Enduraseal insulation system, with more than 20 years of proven performance, is a Reliance standard. Every wound stator goes through multiple vacuum pressure impregnations (VPI), with oven-baked, rotate cured cycles after every impregnation. This process transforms the coils into a solid, rugged structure, free of voids with excellent heat dissipating ability. All insulating materials are rated 'Class F' or better, and are impervious to hydrocarbon oils.

### API Motor Enclosures

- Open Drip Proof
- Weather Protected
  - Type I
  - Type II
- Totally Enclosed
  - Fan Cooled (TEFC)
  - Forced Vent (TEFV)
  - Water Cooled (TEWAC)
  - Tube/Air Cooled (TEAAC)



### Standard API Features

- Copper bar rotor
- Fabricated steel frames
- Fabricated steel end brackets, split for ease of maintenance
- Insulated sleeve bearings - oil ring lubricated
- Coast-to-rest seals
- Caged and supported 8 oz. constant level oilers with stainless steel tubing
- Vertical jackscrews
- Foot mounting holes back spot faced
- Provisions for doweling
- Stainless steel NEMA 2-bolt ground pad
- Foot planity (surface parallel to 0.002 in. per ft.)
- Enduraseal insulation system meets IEEE 429 water immersion test
- Precision balance with API 541 residual unbalance test
- Surge test per IEEE 522
- Gasketed surfaces protected with drip shields Additional features on Weather Protected Type II machines
- Continuously welded hoods crowned for drainage
- Heavy duty stiffeners to eliminate vibration
- Rigid filter support system
- Provisions for air pressure switch

### Optional Features

- Non-contact vibration probes
- Temperature detection for bearings and windings
- Forged steel shaft

### Premium documentation to support premium hardware

Each API 541 motor is supported with a compilation of documentation, customized to meet your specific requirements.

Your fully tested API 541 motor will have a software package that includes:

- Long-term storage bulletin
- Certificate of compliance
- Routine test report
- Quality assurance inspection data
- Water immersion test report
- Phase insulation test reports
- Plastigauge data
- Bearing pattern
- No-load data
- Vibration test data
- Over-speed coast-down test data
- Full load performance data
- Performance curves
- Locked rotor data
- Bearing and stator temperature rise



### All API motors receive the following tests:

- Surge tests of coils per IEEE 522
- Winding immersion per IEEE 429
- Bearing insulation per IEEE 112
- One-hour bearing stabilization
- Coast-down test
- Vibration measurement

### In addition, the following tests may be specified:

- Ultrasonic inspections of forged steel shafts
- Complete full load performance test
- Hot vibration test
- Bearing inspection and plastigauge
- Residual unbalance per paragraph 2.4.7.2.5 of API 541

# Baldor Large AC Motor Capabilities Overview

The reach of Baldor's Large AC Motor product offering is vast. It extends well beyond NEMA frames to ratings as high as 15,000 Hp and as low as 300 RPM. This includes an extensive range of proven cast iron and fabricated steel motors well suited for both General Purpose the Custom (critical service) applications.

Note the following charts which apply to motors meeting these NEMA standards:

- 650% Inrush current
- Equal or greater than NEMA, Part 20 design torques (as described by NEMA for Above NEMA Motors)
- Standard NEMA voltage for each horsepower rating

- Minimum 90% Reduced Voltage Start
- NEMA specified (or less) load inertia applied to the motor shaft
- Inverter powered capabilities limited to Variable Torque loads
- Altitude below 3300 feet (above sea level)
- Operating ambient of 40°C (or lower)
- Horizontal foot mounted
- Centrifugal loads
- Direct coupled

The list of Baldor•Reliance Custom design capabilities and features is even more impressive. Please contact a Baldor office for details.

## Open Motors

Poles	2	4	6	8	10	12	14	16	18	20	22	24
60 Hz RPM	3600	1800	1200	900	720	600	514	450	400	360	327	300
150	E447	E447	E449	E449	E5008	E5010	E5808					
200	E447	E447	E449	E5006	E5008	E5010	E5808					
250	E447	E449	E5006	E5006	E5010	E5808	E5808	6811			9240	9240
300	E449	E449	E5006	E5008	E5010	E5808	E5810	6811	8040	9240	9240	9240
350	E449	E449	E5006	E5010	E5808	E5808	E5810	6811	8040	9240	9240	10840
400	E449	E5006	E5008	E5010	E5808	E5810	E5812	6811	8040	9240	9240	10840
450	E449	E5008	E5010	E5012	E5808	E5810	E5812	6811	9240	9240	10840	10840
500	E5008	E5008	E5010	E5012	E5808	E5812	E5812	6813	9240	9240	10840	10840
600	E5008	E5008	E5010	E5808	E5810	E5812	6813	6813	9240	9240	10840	10840
700	E5010	E5010	E5012	E5810	E5812	E5812	6813	8040	9240	9240	10840	10840
800	05808	E5010	E5810	E5810	E5812	6811	6813	9240	9240	10840	10840	10840
900	05808	E5012	E5810	E5812	E5812	6813	8040	9240	9240	10840	10840	10840
1000	05808	E5012	E5810	E5812	6813	6813	8040	9240	9240	10840	10840	10840
1250	05810	E5810	E5812	E5812	6813	9240	9240	9240	10840	10840	10840	900
1500	05810	E5810	E5812	6811	6813	9240	9240	9240	10840	10840	900	
1750	05810	E5812	6811	6813	9240	9240	9240	10840	10840	900		
2000	05812	E5812	6813	6813	9240	9240	9240	10840	10840			
2250	05812	6811	6813	9240	9240	9240	10840	10840	900			
2500	05812	6811	6813	9240	9240	10840	10840	10840	900			
2750	6811	6813	9240	9240	10840	10840	10840	900				
3000	6811	6813	9240	9240	10840	10840	10840	900				
3500	6813	6813	9240	9240	10840	10840	10840	900				
4000	6813	9240	9240	10840	10840	10840	900					
4500	6813	9240	10840	10840	10840	900	900					
5000	6813	10840	10840	10840	10840	900						
5500	630	10840	10840	10840	900	900						
6000	630	10840	10840	10840	900	900						
7000	630	10840	900	900	900							
8000		10840	900	900	900							
9000		900	900	900								
10000		900	900	900								
11000		900	900									
12000		900										
13000		900										
14000		900										
15000		900										

## Closed Motors

Poles	2	4	6	8	10	12	14	16	18	20	22	24
60 Hz RPM	3600	1800	1200	900	720	600	514	450	400	360	327	300
100			G447									
125	G449	G447	G447									
150	G449	G447	G447	G5008	G5010	G5010						
200	G449	G449	G449	G5008	G5010	G5012	G5810					
250	G5008	G449	G449	G5010	G5012	G5012	G5810	6811	8040			
300	G5008	G449	G449	G5010	G5012	G5810B	G500S	6811	8040	9240	9240	9240
350	G5008	G449	G5010	G5012	G5810	G500S	G500S	6811	9240	9240	9240	9240
400	G5010	G449	G5012	G5012	G5810	G500S	G500S	6811	9240	9240	9240	10840
450	G5010	G5010	G5012	G5012	G5810B	G500S	G500S	6813	9240	9240	9240	10840
500	G5010	G5010	G5012	G5012	G500S	G500S	G500S	6813	9240	9240	10840	10840
600	G5010	G5012	G5012	G5810	G500S	G500S	G500S	8040	9240	9240	10840	10840
700	G5810	G5012	G5810B	G500S	G500S	G500M	G500M	9240	9240	10840	10840	10840
800	G5810B	G5012	G500S	G500S	G500M	G500M	8040	9240	9240	10840	10840	10840
900	G500M	G5012	G500S	G500S	G500M	G500M	9240	9240	10840	10840	10840	10840
1000	G500M	G5810	G500S	G500S	G500S	9240	9240	9240	10840	10840	10840	10840
1250	G500M	G500M	G500S	G500M	6813	9240	9240	9240	10840	10840	10840	10840
1500	G500M	G500M	G500M	G500M	9240	9240	9240	10840	10840	900	10840	900
1750	6811	G500M	G500M	9240	9240	9240	10840	10840	900		900	
2000	6811	G500M	9240	9240	9240	9240	10840	10840	900			
2250	6811	G500M	9240	9240	9240	10840	10840	10840				
2500	6813	6813	9240	9240	10840	10840	10840	900				
2750	6813	6813	9240	9240	10840	10840	10840	900				
3000	6813	6813	9240	10840	10840	10840	900	900				
3500	6813	9240	10840	10840	10840	10840	900					
4000	6813	10840	10840	10840	10840	900						
4500	630	10840	10840	10840	10840	900						
5000	630	10840	900	900	900	900						
5500	630	10840	900	900	900							
6000	630	10840	900	900	900							
7000	630	900	900	900	900							
8000	630	900	900									
9000		900										
10000		900										
11000		900										
12000												
13000												
14000												
15000												

### Important Notes:

- Charts are based on designs in accordance with NEMA MG1:20.
- Enhanced cooling blower systems (provided on the motor) may be required depending on application requirements.
- Slower speed, higher pole count designs are available upon request.

Cast Frames

Fabricated Steel Frames

### Important Notes:

- Charts are based on designs in accordance with NEMA MG1:20.
- Fabricated steel frames are TEAAC enclosure.
- Enhanced cooling blower systems (provided on the motor) may be required depending on application requirements.
- Slower speed, higher pole count designs are available upon request.

# ABB Large AC Motor Capabilities Overview

## Synchronous motors

- Ranging up to 70MW / 94,000 Hp
- 20 - 2000 rpm (also 2 pole available)
- Shaft height 0710 - 2500 mm
- Ranging from 1 - 60 kV
- Endshield and pedestal mounted, horizontal and vertical design
- All main cooling types
- Motor design for hazardous environment according to main Ex standards
- All main DOL starting methods and VSD technology supported



## Induction motors

- Ranging up to 13.8 kV and 23 000 kW / 30 000 HP
- Motor types AMA and AMI
- Shaft heights 400 to 1000 mm
- Poles 2 to 20
- 50 and 60 Hz
- Ambient -50°C to +60°C, Ambient -58°F to +140°F
- Suitable for IEC, EN and NEMA standards
- Motors for safe and hazardous areas
- Motors for onshore and offshore applications
- Horizontally or vertically mounted



**Synchronous Motors – Output Ratings at Different Speeds**

Output (MW)	Fixed Speed Motors												
	Speed (RPM)												
	1900	1500	1000	750	600	500	429	375	333	300	273	250	140
5													
10													
15													
20													
25													
30													
35													
40													
45													
50													
55													
60													
65													
70													

Output (MW)	Variable Speed Motors												
	Speed (RPM)												
	2000	1500	1000	750	600	500	429	375	333	300	273	250	20
5													
10													
15													
20													
25													
30													
35													
40													
45													
50													

Output ranges of ABB synchronous motors (from 1 to 70 MW, 1 to 15 kV).

 Fabricated Steel Frames

**Induction Motors – Output Ratings at Different Speeds**

Output (MW)	Speed (RPM)												
	3000	1500	1000	750	600	500	429	375	333	300	273	250	
1													
2													
3													
4													
5													
6													
7													
8													
9													
10													
11													
12													
13													
14													
15													
16													
17													
18													
19													
20													
21													
22													
23													
24													
25													

Examples of output at 50 Hz

## Two Pole AC Induction Motors XL560/630 Frames

### **Designed for Variable-Speed Operation**

Unlike motors that are just modified or re-rated for variable-speed operation, the XL560/630 line was designed from the ground up for operation on inverter power. This line of motors leverages the 70 plus years of Reliance Electric variable-speed technology to provide rugged and reliable performance in usual and unusual operating environments.

### **Standard Features**

- NEMA enclosures:
  - Weather protected, Type I and II (WPI and WPII)
  - Totally-enclosed air-to-air cooled (TEAAC)
  - Totally-enclosed water-to-air cooled (TEWAC)
  - Totally-enclosed force ventilated (TEFV)
- Low acoustic noise - typical no load sound pressure level of 85 dBA at 1 meter.
- High efficiency designs for minimum energy usage.
- Reinforced, corrosion-resistant full frame construction for long-term strength while minimizing vibration and assuring stable driven equipment alignment.
- Integrally designed foot mounting pads with provisions for doweling and jacking ensure ease-of-installation and proper driven equipment alignment.
- Large motor shaft diameter minimizes deflection and vibration to extend bearing life.
- Rotors are made from C5 lamination steel. Laminations are stacked, mechanically compressed and keyed to the shaft for maximum mechanical integrity. Rotors are designed with a slot design that effectively minimizes magnetic noise while providing smooth speed/torque operation.
- The premium Enduraseal Class F insulation system is used for optimal electrical and mechanical performance and service life. This system has proven to be the most effective choice to withstand the rigors of high temperatures and voltages as well as mechanical stresses caused by unusual operations such as plug reversals.
- “DIN” standard hydrodynamic self-aligning sleeve bearings with oil rings.
- Manufactured in an ISO9001 registered facility, your best assurance of quality.

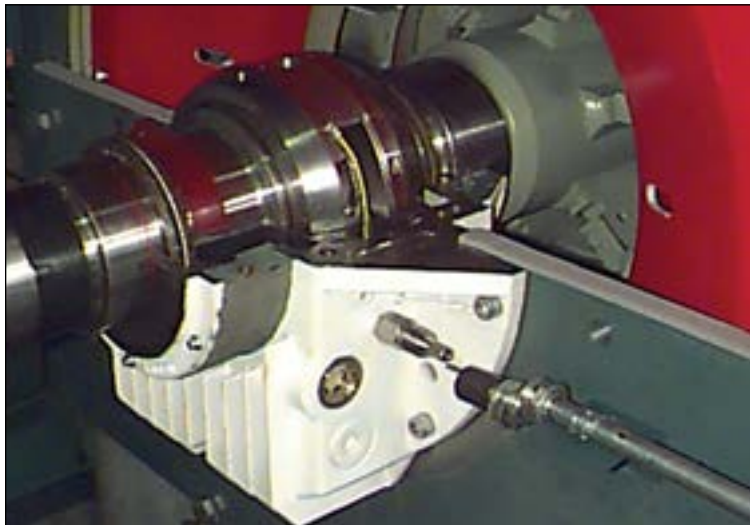

▲ *Tilting Pad Bearing*

◀ *Sleeve Bearing*

# Two Pole AC Induction Motors

## XL560/630 Frames

### 630 Frame Technical Data (highly damped design+)

**Ratings:**

3000 HP, 3500HP, 4000HP, 4500HP, 5000HP, 5500HP, 6000HP, 6500HP, 7000HP  
2300 and 4000 Volt standard  
Other voltages available

**Insulation System:**

Service proven Enduraseal Insulation system  
Class F standard  
Sealed with immersion test IEEE 429 standard  
IEEE 522, 3.5 pu surge capability standard

**Enclosures:**

WP I, WP II, TEWAC, TEFV, TEAAC

**Starting Capabilities:**

Suitable for adjustable frequency drives (AFD)  
Across the line option for most applications

**Variable Speed Operation:**

10% maximum overspeed capability  
Critically Damped System - resonances in the operating speed range are damped per API 617 (6th edition), Section 2.9.1.3 (amplification factor less than 2.5)

**Vibration Capabilities** (synchronous speed):

1.5 mil p-p shaft displacement  
0.5 mil p-p bracket displacement  
0.1 in/sec bracket velocity  
Hot vibration performance will be tested in accordance with paragraph 4.3.3.11 of API 541 (3rd edition).

**Cooling Requirements:**

For all TEWAC & TEAAC enclosures - cooling to be supplied by external blowers

**Enclosure Availability:**

HP	WPI	WPII	TEWAC	TEAAC	TEFV
3000	✓	✓	BC	BC	✓
3500	✓	✓	BC	BC	✓
4000	✓	✓	BC	BC	✓
4500	✓	✓	BC	*	✓
5000	✓	✓	BC	*	✓
5500	✓	✓	BC	*	✓
6000	✓	✓	BC	*	✓
6500	✓	✓	BC	*	✓
7000	✓	✓	BC	*	✓

BC = Supplemental blower cooled  
\* = Design to be reviewed by engineering  
+ = Motor design permits operation on critical speed

**Sound Levels:**

WP II, TEWAC, TEFV - overall average 85 dBA at 1 meter  
WP I – overall average 100 dBA at 1 meter  
TEAAC – overall average 90 dBA at 1 meter

**Shaft:**

4140 shaft material up to 5000 hp & 4340 shaft material above 5000HP  
All shafts are of a spider design  
All shafts available as one-piece forging

### 560 Frame Technical Data (rigid shaft design)

**Ratings:**

- 1750 HP, 2000 HP, 2250 HP, 2500 HP, 2750 HP
- 2300 and 4000 Volt standard
- Other voltages available

**Insulation System:**

- Service proven Enduraseal Insulation system
- Class F standard
- Sealed with immersion test IEEE 429 standard
- IEEE 522, 3.5 pu surge capability standard

**Enclosures:**

- WP I, WP II, TEWAC, TEFV, TEAAC

**Starting Capabilities:**

- Suitable for variable frequency drives (VFD)
- Across the line option for most applications

**Critical Speed:**

True rigid shaft design with tilting pad bearing. Critical speed minimum 15% above synchronous speed.

**Vibration Capabilities** (synchronous speed)

- 1.5 mil p-p shaft displacement
- 0.5 mil p-p bracket displacement
- 0.1 in/sec bracket velocity  
Hot vibration performance will be tested in accordance with paragraph 4.3.3.11 of API 3rd edition.

**Cooling Requirements:**

- 1750, 2000, 2250 HP TEAAC - cooling to be supplied by external blowers  
**NOTE:** 2500, 2750 HP designs are not available with the TEAAC enclosure

**Enclosure Availability:**

HP	WPI	WPII	TEWAC	TEAAC	TEFV
1750	✓	✓	✓	BC	✓
2000	✓	✓	✓	BC	✓
2250	✓	✓	✓	BC	✓
2500	✓	✓	✓	—	✓
2750	✓	✓	✓	—	✓

BC = Supplemental blower cooled

**Sound Levels:**

- WP II, TEWAC, TEFV - overall average 83 dBA at 1 meter
- WP I – overall average 100 dBA at 1 meter
- TEAAC – overall average 88 dBA at 1 meter

**560 Frame Tilt Pad Bearing**

- Shell equipped with tilt pad
- No Oil rings
- Requires force lube
- Required oil flow rate of ½ USGPM at 15 to 20 PSI ( 1.9L/min) per bearing
- Oil inlet thread size: BSP/ISO .38 parallel female thread
- Oil outlet thread size: 1¼ NPT male thread
- Operating speed range of the tilt pad bearing for VFD applications: 100 – 3960 RPM

## Vertical AC Induction Motors

All Baldor•Reliance vertical motors incorporates the proven performance and features found in all Reliance Large AC motors.

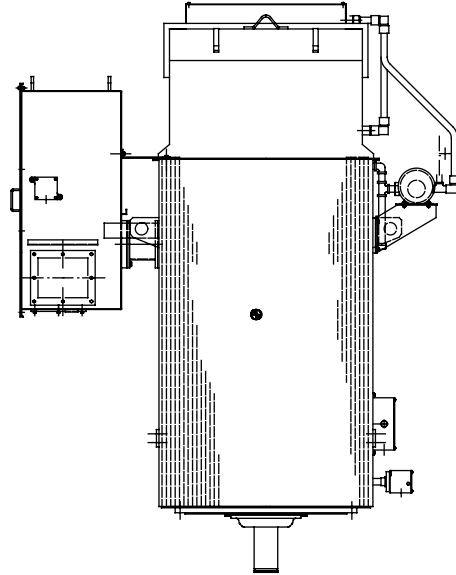
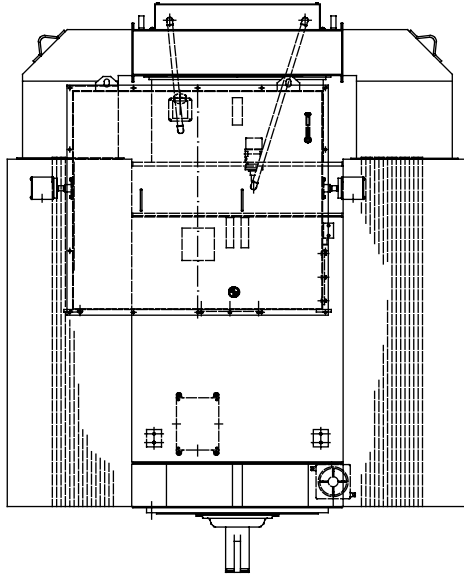

**HP: 1500 RPM: 720**  
**Frame: V9240**  
**Enclosure: WP-I**  
**Application: Pump**  
**Industry: Water Treatment Plant**



**HP: 650 RPM: 900;**  
**Frame: V0840**  
**Enclosure: TEAO;**  
**Application: Tunnel Ventilation Fan**  
**(to be located in the One World Trade**  
**Center - formerly known as the**  
**Freedom Tower)**  
**Industry: Air Handling**



**HP: 900 RPM: 1200 (with a 20 Hp, 300 RPM**  
**pony motor) Frame: V10840**  
**Enclosure: TEWAC;**  
**Application: Moderator Pump**  
**Industry: Nuclear Generating Station**

## Vertical AC Motors



**HP: 350 RPM: 1800**  
**Frame: V5830**  
**Enclosure: DPG**  
**Application: Moderator Pump**  
**Industry: Nuclear Generating Station**



**HP: 600 RPM: 360**  
**Frame: V9240**  
**Enclosure: WPII**  
**Application: Centrifugal Pump**  
**Industry: Coal Fired Generating Station**

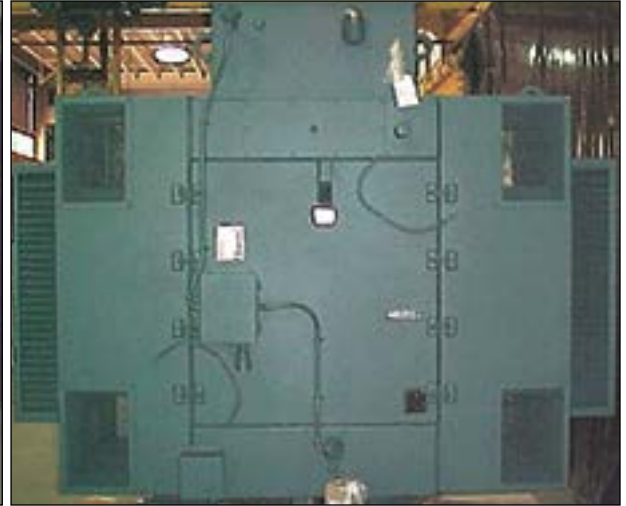

**HP: 650 RPM: 1200**  
**Frame: V6840**  
**Enclosure: WPII**  
**Application: Centrifugal Pump**  
**Industry: Oil and gas**

Standard enclosures include DP, WPI, WPII, TEWAC, and TEAAC. Specialty designs are also available, with a virtually limitless selection of custom features.

Standard voltages available are 460 to 13.2 KV.

Standard HP available 300 to 15,000

Accessories available are the same as on our horizontal product line as well as vertical specific items such as non-reverse ratchets.

### **L-10 Life:**

Rating life, L10 (B10), is the life in hours or revolutions in which 90% of the bearings selected will obtain or exceed before showing the first signs of fatigue in race or rolling element. Median life (average life), L50 (B50), is the life in hours or revolutions in which 50% of the bearings selected will obtain or exceed. The median life is approximately five times the L-10 life.

All conditions of thrust must be considered, design & momentary values as well as any applicable amount of upthrust.

Baldor•Reliance standard L-10 Life is 2 years.  
Typical L-10 Life is 50,000 and 100,000 hours.

<b>Bearing</b>	<b>Lubrication</b>	<b>Cooling Method</b>	<b>Thrust Classification</b>
<b>Angular Contact</b>	Oil or Grease	Air or Water	Low
<b>Double Angular Contact</b>	Oil or Grease	Air or Water	Low
<b>Spherical Roller Thrust</b>	Oil or Grease	Air or Water	Medium to High
<b>Tilting Pad</b>	Oil	Water or Oil Circulation	High

# Extra-Large AC and Custom Motors

**Performance**

Baldor•Reliance Excel motors are field proven through countless service hours in the most rigorous applications that industry has to offer.



**Value**

Every Excel motor is the product of over 50 years of experience designing and manufacturing large AC motors. The Baldor•Reliance program of continuous quality improvement ensures that our motors meet world-class standards of excellence with the ultimate goal of customer satisfaction.

Excel horizontal and vertical motors are manufactured under ISO 9001 quality certification for consistent, predictable performance. These motors meet or exceed many of the most critical performance specifications worldwide, including military and nuclear guidelines and API-541.

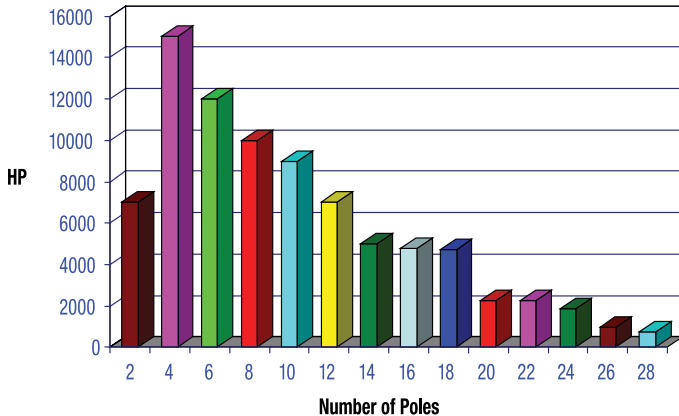

**Reliability**

Baldor•Reliance Excel AC induction motors are at the heart of every process and system they drive. Every Excel horizontal or vertical motor is a carefully conceived, integrated system of electrical and mechanical components designed for dependable, predictable performance in the most demanding applications.

**Versatility**

These high-performance motors are available for constant- speed, variable-frequency, and variable-speed applications. Standard enclosures include Protected, WPI, WPII, TEWAC, and TEAAC. Specialty designs are also available, with a virtually limitless selection of custom features.

Baldor•Reliance takes pride in designing and manufacturing motors to each customer's precise application requirements. Whether your environmental exposure involves water, chemicals, carbon, black liquor, radiation, or abrasion, we can provide the right combination of materials, enclosures, bearing systems, and accessories to achieve optimum long-term performance.

We also offer a full range of performance-protection options such as thermal and vibration monitoring systems, special lubrication arrangements, over-current protection, surge arresters, and filters. Other accessories include space heaters, temperature detecting equipment, and tachometers.

## Extra-Large AC and Custom Motors



This 3500HP, 3/60/4000 Volt, 3600 RPM, TEFV horizontal motor is powering a pump on an oil pipeline.

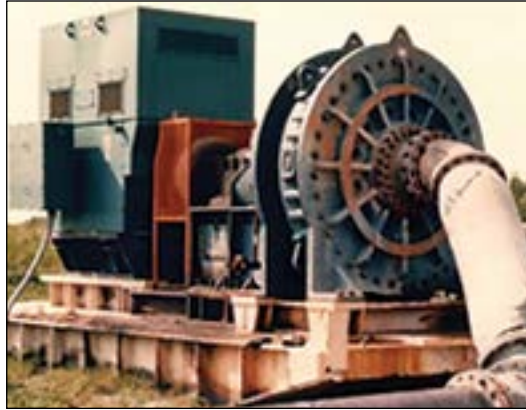

This Excel 1500HP, 514 RPM, 4 kV horizontal motor is powering matrix booster pump in a Florida phosphate mine.



This 900/20HP, 3/60/4000 Volt, 1200/300 RPM, TEWAC vertical motor is powering main moderator pump in a nuclear generating station.

### Performance Features

Fabricated, reinforced, corrosion-resistant steel frames provide added strength and rigidity, eliminate vibration, and ensure stable alignment. The steel laminations are mill-coated with high-grade enamel for better operating efficiency and cooler operation.

Integrally designed foot mounting pads are provided, with provisions for doweling and jacking, to ensure proper alignment. Mounting configurations are available for a variety of standard applications or custom-designed for special applications.

The exclusive Baldor•Reliance Enduraseal® Class F insulation system uses copper stator coils wrapped in multiple layers of NOMEX® mica tape for exceptional corona resistance in high-voltage applications.

An outer layer of glass armour tape provides added protection from abrasion. The wound stator cores receive multiple Vacuum Pressure Impregnations (VPI), to fill all voids with an 100% epoxy solids formulation. The exclusive Reliance curing process, and rigorous water testing, ensures IEEE 429 compliance. The coils are all rigidly lashed and where applicable to a steel bracer ring to reduce stress related to frequent start-ups for extended stator life.

Oversized oil reservoirs help ensure adequate lubrication while effectively dissipating heat.

Large shaft diameters minimize deflection and vibration for extended bearing life. A wide range of shaft materials, including AISI 4340 grade and forged steel, are available.

Steel plate bearing brackets are generously designed to accommodate bearing enclosures and support rotor weight without distortion.

### Bearing Selection Guide

Bearing Types	Mounting	
	No Thrust	Thrust
Deep Groove Ball	H-V	V
Sleeve	H-V	–
Cylindrical Roller	H	–
Angular Contact	V	H-V
Spherical Roller	V	V
Pad Bearings	–	V



Rotor laminations are stacked, mechanically compressed, retained, and shrunk fit to the shaft or spider. Vent ducts provide cooling. Slot configurations are selected to reduce magnetic noise and smooth the speed-torque curve. Rotor bars are high-temperature brazed to the copper end rings and constructed of copper or copper alloy materials to meet specific application requirements for optimum motor efficiency.

# Replacement and Specialty Custom Engineered Motors

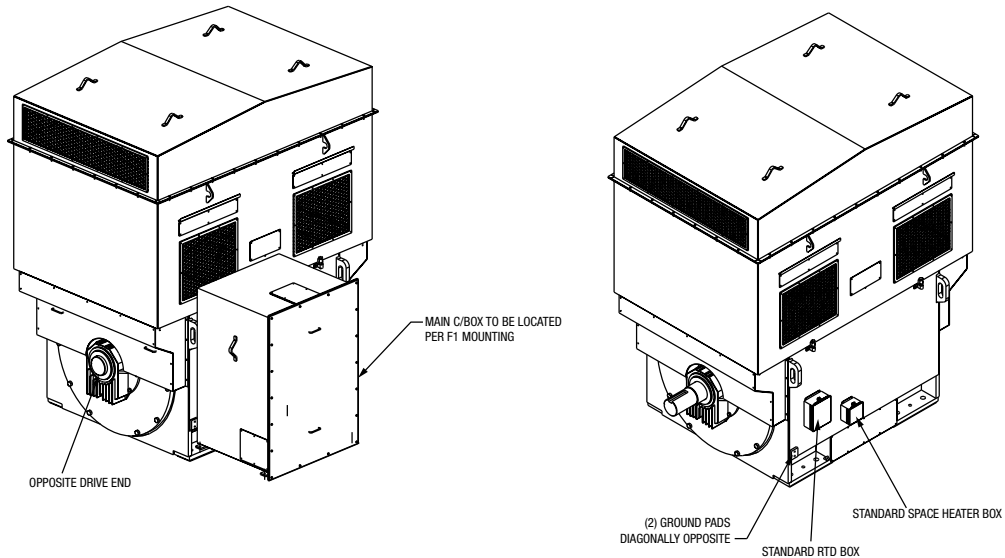
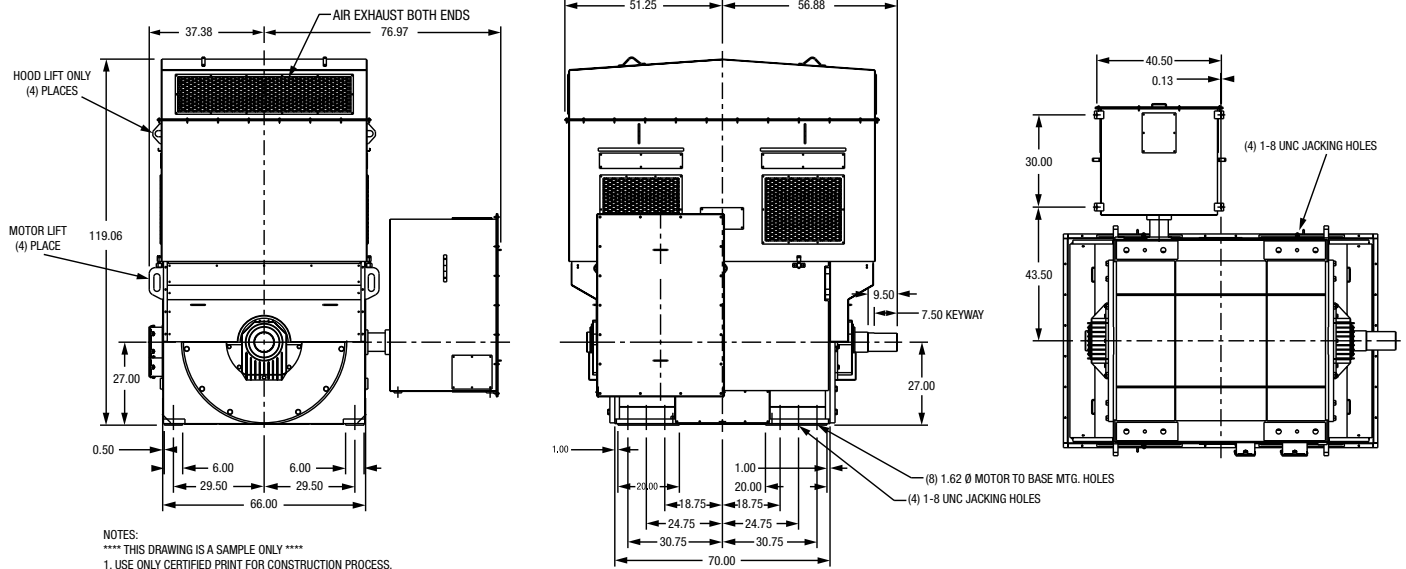

# Replacement and Specialty Custom Engineered Motors

## Construction:

Baldor•Reliance Electric fabricated steel construction allows for drop in replacement of many competitors products whether older or current designs. Many of these replacement motors can offer significant Horsepower upgrades

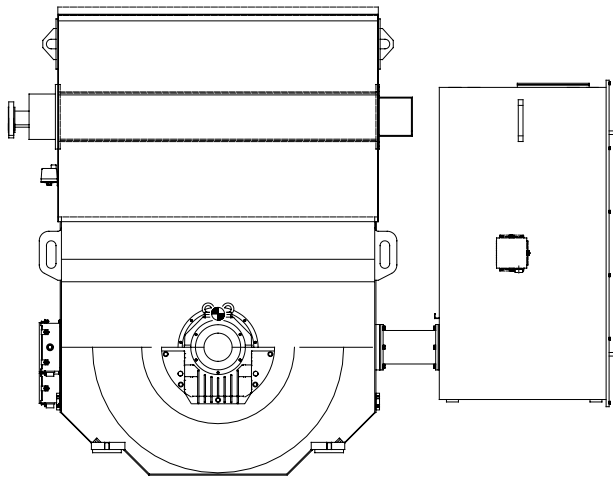

**Horizontal Motor  
with custom base  
Original 3000 HP  
Replacement 6000 HP**

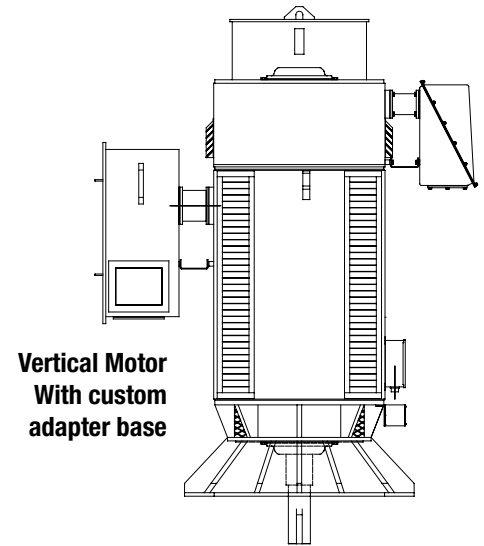

**Vertical Motor  
With custom  
adapter base**

## Custom Features:

### Sensors

A wide range of protection and sensing options are available.

- *Temperature* – RTD's , Thermometers , Thermocouples and Telemetry
- *Vibration* – Switches, accelerometers, probes and proximeters
- *Insulation Life* – Iris and Insulguard systems

### Bearing Configurations

- Anti-friction (SRT, A/C), sleeve, tilting pad, magnetic
- Grease and oil lubricated
- Air, water and oil cooled

### Electrical

Baldor•Reliance will optimize your design to offer the best efficiency possible. As well we can meet other demanding criteria such as high inertia, low inrush, and high starting duty. Also a wide variety of insulation systems and treatments are available to satisfy your specific requirements.

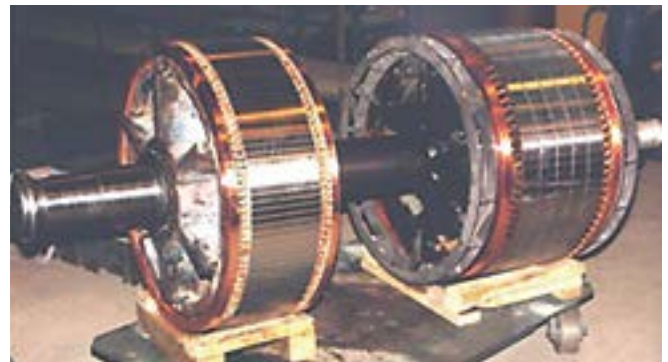

**Vertical TEWAC 900HP -1200 RPM  
with a 20 HP – 300 RPM Pony Motor**



**Dual TEWAC exchanger hoods**

## Open Drip Proof and WPI

### Standard Frame Selections

Baldor•Reliance motors have served industry for over 50 years with leading technologies that yield reliable low cost operation. In keeping with this tradition all Baldor•Reliance motors are designed to meet our own rigid efficiency standards that exceed industry norms. By incorporating the highest grade materials available and best in the world manufacturing processes, Baldor•Reliance motors have lower losses and consume less energy at the customer's site.

Open and weather protected motors typically drive pumps, compressors, fans, conveyors, machine tools in a variety of process and general purpose applications.



### Energy Efficient 460 or 575 Volts, 60 Hz, 1.15 SF

Hp	kW	RPM			
		3600	1800	1200	900
150	112	449TS/E447	449TS/E447	E449	E5006
200	150	449TS/E447	449TS/E447	E5006	E5006
250	187	449TS/E449	449T/E449	E5006	E5008
300	224	449TS/E449	449T/E449	E5006	E5010
350	261	E449	E5006	E5008	E5010
400	298	E449	E5008	E5010	E5012
450	336	E5008	E5008	E5010	E5012
500	373	E5008	E5008	E5010	5808/E5012
600	448	E5010	E5010	E5012	5810/05810
700	522	E5010	E5010	5808/E5810	5810
800	600	5808S/05808	5011L/E5012	5810/05810	E5812
900	671	5808S/05808	5808/E5012	5812/05810	E5812
1000	746	5808S/05808	5810/05808	E5812	E5812

Note: 5000 & 5800 frame motors can be ODP or WPI.

### Energy Efficient 2300 or 4000 Volts, 60 Hz, 1.15 SF

Hp	kW	RPM			
		3600	1800	1200	900
150	112	449TS/E447	449TS/E447	E449	E5006
200	150	449TS/E447	449TS/E447	E5006	E5006
250	187	449TS/E449	449T/E449	E5006	E5008
300	224	449TS/E449	449T/E449	E5006	E5010
350	261	E449	E5006	E5008	E5010
400	298	E449	E5008	E5010	5808/E5012
450	336	E5008	E5008	E5010	5808/E5012
500	373	E5008	E5008	E5010	5810/E5012
600	448	E5010	E5010	5808/E5012	5810/05810
700	522	E5010	E5010	5810/05810	5812/05810
800	600	5808S/05808	5808/E5012	5812/05810	E5812
900	671	5808S/05810	5810/05808	5810/05810	E5812
1000	746	05810/05808	5810/05808	E5812	E5812
1250	933	05810	5810	E5812	E5812
1500	1119	05810	E5812	6811	6811
1750	1305	05812	E5812	6811	—
2000	1492	05812	E5812	6813	—
2250	1678	6811	6811	—	—
2500	1865	6811	6811	—	—
2750	2051	6811	6813	—	—
3000	2238	6811	6813	—	—

Note: 5000 & 5800 frame motors can be ODP or WPI.

Data subject to change without notice. Contact a Baldor office for latest capabilities.

## Open Drip Proof and WPI

### Standard Frame Selections

Open Drip Proof motors are cooled by forcing ambient air into the motor interior and over the rotor and stator. So these motors are typically used indoors where the air is reasonably clean, non corrosive and free of spraying water.

Weather Protected Type I (WPI) motors are also open motors. But the ventilation system is designed to minimize the effects of moisture and airborne particles. The mechanical and electrical components are also resistant to contaminated atmospheric conditions.

When selecting a WPI motor, the user needs to be aware that moisture and particulates in the atmosphere can still build up on the rotor and stator. Eventually, this can restrict air flow and limit heat dissipation in the rotor and stator. Over time this may cause the motor to run hotter and reduce its life. However this condition can be mitigated by periodic service that includes cleaning the interior components including the rotor and stator.

All things considered, WPI motor applications are typically limited to clean, dry and indoor applications.



### Energy Efficient 6600 volts, 60 Hz, 1.15 SF

Hp	kW	RPM			
		3600	1800	1200	900
250	187	E5008	—	—	—
300	224	E5008	E5010	—	—
350	261	E5008	E5010	—	—
400	298	E5008	E5010	E5808	E5810
450	336	E5008	E5010	E5808	E5810
500	373	E5008	E5010	E5808	E5810
600	448	E5808	E5012	E5810	E5810
700	522	E5808	E5012	E5810	E5812
800	600	E5808	E5808	E5810	E5812
900	671	E5810	E5808	E5812	E5812
1000	746	E5810	E5810	E5812	E5812
1250	933	E5810	E5810	6811	6811
1500	1119	6811	E5812	6811	6811
1750	1305	6811	E5812	6811	—
2000	1492	6813	6813	—	—
2250	1678	6813	6813	—	—
2500	1865	6813	—	—	—

**Note:** Data subject to change without notice. Contact a Baldor office for latest capabilities.

## WP11

### Standard Frame Selections

Weather Protected Type II (WP11) motors are cooled with ambient air. But they are also designed with a ventilation system that routes particulates present in the ambient air to be discharged without getting into the motor interior housing and its electrical components. This is achieved with a top hood or bonnet mounted over the motor housing and a baffling system that reduces the air velocity thereby allowing heavier particles to settle. Ventilation is provided by a shaft mounted fan located inside the housing.

WP11 motors are typically used for outdoor applications, although filters are highly recommended.

Baldor•Reliance WP11 top hoods for O5800 and O6800 frames are uniquely designed with a crowned top and 11 gage steel. Drip shields are provided to protect the filter access doors. The filter access doors are hinged and filters can be changed while the motor is running. Customers also benefit from superior noise suppression material in the top hood, a very robust method for attaching the hood to the housing and an easy hood mounting scheme. Noise suppression is improved further by an additional baffle on the hood exhaust rather than simple direct air discharge.

Enclosure enhancements are available such as stainless steel hardware, tropical protection for shipping, arctic and marine duty provisions, abrasive treatment for the motor windings and ingress protection.



### Energy Efficient 460 or 575 Volts, 60 Hz, 1.15 SF

Hp	kW	RPM			
		3600	1800	1200	900
150	112	E5006	E5006	E5006	E5006
200	150	E5006	E5006	E5006	E5006
250	187	E5006	E5006	E5006	E5008
300	224	E5006	E5006	E5008	5810L/E5010
350	261	E5006	E5006	E5008	5810L/E5012
400	298	E5006	E5008	E5010	5810L/E5012
450	336	E5008	E5008	E5010	5810L/5808/E5012
500	373	E5008	E5008	E5010	E5808
600	448	E5010	E5010	E5012	E5810
700	522	5808S/E5010	E5012	5810L/O5810	E5810
800	600	5808S/E5808	5810L/E5012	5810L/O5810	E5812
900	671	O5808	5810L/O5808	5812L/E5810	E5812

### Energy Efficient 2300 or 4000 Volts, 60 Hz, 1.15 SF

Hp	kW	RPM			
		3600	1800	1200	900
150	112	E5006	E5006	E5006	E5006
200	150	E5006	E5006	E5006	E5006
250	187	E5006	E5006	E5006	E5008
300	224	E5006	E5006	5810L/E5008	5810L/E5010
350	261	E5006	E5006	E5008	5810L/E5012
400	298	E5006	E5008	E5010	5810L/E5012
450	336	E5008	E5008	E5010	5812L/E5808
500	373	E5008	E5008	E5010	E5808
600	448	E5010	E5010	5808/E5012	E5810
700	522	5808S/E5010	E5012	5810L/O5810	E5810
800	600	E5808	5810L/E5012	5810L/O5810	E5812
900	671	5808S/O5808	5810L/O5808	5812L/E5812	E5812
1000	746	5810S/O5808	5810L/O5810	E5812	E5812
1250	933	5810S/O5810	5812L/O5812	O5812	6811
1500	1119	O5810	O5812	6811	6811
1750	1305	O5812	O5812	6811	—
2000	1492	O5812	6811	6813	—
2250	1678	6811	6811	—	—
2500	1865	6811	6811	—	—
2750	2051	6811	—	—	—
3000	2238	6811	—	—	—

Note: Data subject to change without notice. Contact a Baldor office for latest capabilities.

# WP11

## Standard Frame Selections

### Energy Efficient 6600 volts, 60 Hz, 1.15 SF

Hp	kW	RPM			
		3600	1800	1200	900
250	187	E5008	—	—	—
300	224	E5008	E5010	—	—
350	261	E5008	E5010	—	—
400	298	E5008	E5010	05808	E5810
450	336	E5008	E5010	05808	E5810
500	373	E5008	E5010	05808	E5810
600	448	E5808	E5010	05810	E5810
700	522	E5808	E5012	05810	E5812
800	600	E5808	E5012	05810	E5812
900	671	E5810	E5808	05812	E5812
1000	746	E5810	E5010	05812	6811
1250	933	E5810	E5810	6811	6811
1500	1119	E5810	E5810	6811	—
1750	1305	E5810	E5812	6811	—
2000	1492	6811	E5812	—	—
2250	1678	6811	—	—	—

**Note:** Data subject to change without notice. Contact a Baldor office for latest capabilities.



# TEFC – Totally Enclosed Fan Cooled

## Standard Frame Selections

Totally enclosed motors are completely enclosed so ambient air does not pass over interior components. Cooling is provided by a shaft mounted external fan that blows air over the ribbed housing.

The enclosed families of motors serve industry applications requiring protection against corrosion caused by severe and harsh environmental operating conditions. Typical applications include Petrochemical plants, mines, foundries, pulp and paper plants, waste management facilities and other critical processes.

## Energy Efficient 460 or 575 Volts, 60 Hz, 1.15 SF

Hp	kW	RPM			
		3600	1800	1200	900
150	112	E449	E449	E449	G5008
200	150	E449	E449	G5008	G5008
250	187	G5008	G5008	G5008	G5010
300	224	G5008	G5008	G5010	G5010
350	261	G5008	G5008	G5010	G5012
400	298	G5010	G5008	G5012	G5012
450	336	G5010	G5010	G5012	G5012
500	373	G5010	G5010	G5012	G5012
600	448	G5012/G5810	G5012	G5012	G5000/G5810
700	522	G5012/G5810	G5012	G5000/G5810	G5000/G5810
800	600	G5012/G5810	G5012	G5000/G5810	G5800/G500S
900	671	G5012/G5810	G5012	G5800/G500S	G5800/G500S

**Note:** Data subject to change without notice. Contact a Baldor office for latest capabilities.



*This is an API 541 TEFC G500M motor operating a compressor in a petroleum refinery.*

# TEFC – Totally Enclosed Fan Cooled

## Standard Frame Selections



### Energy Efficient 2300 or 4000 Volts, 60 Hz, 1.15 SF

Hp	kW	RPM			
		3600	1800	1200	900
150	112	449TS/E449	449T/E449	449T/E449	G5008
200	150	449TS/E449	449T/E449	G5008	G5008
250	187	G5008	G5008	G5008	G5010
300	224	G5008	G5008	G5010	G5010
350	261	G5008	G5008	G5010	G5012
400	298	G5010	G5008	G5012	G5012
450	336	G5010	G5010	G5012	G5012
500	373	G5010	G5010	G5012	G5012
600	448	G5010	G5012	G5012	G5810
700	522	G5810	G5012	G5810	G5810
800	600	G5810	G5012	G5810	G500S
900	671	G5810	G5012	G500S	G500S
1000	746	G500M	G5810	G500S	G500S
1250	932	G500M	G5810	G500S	G500M
1500	1119	G500M	G500M	G500M	G500M
1750	1305	—	G500M	G500M	—
2000	1492	—	G500M	—	—
2250	1678	—	G500M	—	—

### Energy Efficient 6600 Volts, 60 Hz, 1.15 SF

Hp	kW	RPM			
		3600	1800	1200	900
150	112	—	—	—	—
200	150	—	—	—	—
250	187	G5010	G5010	G5810	G5810
300	224	G5010	G5010	G5810	G5810
350	261	G5010	G5010	G5810	G5810
400	298	G5010	G5010	G5810	G5810
450	336	G5010	G5012	G5810	G5810
500	373	G5810	G5012	G5810	G5810
600	448	G5810	G5012	G5810	G500S
700	522	G5810	G5012	G500S	G500S
800	600	G5810	G5810	G500S	G500S
900	671	G500M	G5810	G500S	G500M
1000	746	G500M	G5810	G500S	G500M
1250	932	G500M	G500M	G500M	G500M
1500	1119	G500M	G500M	G500M	—
1750	1305	—	G500M	—	—
2000	1492	—	—	—	—
2250	1678	—	—	—	—

**Note:** Data subject to change without notice.  
Contact a Baldor office for latest capabilities.

## TEAAC – Totally Enclosed Air to Air Cooled

### Standard Frame Selections

Totally Enclosed Air to Air Cooled motors are completely enclosed so ambient air does not pass over interior components. Cooling air for the rotor and stator is provided by a shaft mounted fan mounted inside the motor housing. The air is routed through an air to air heat exchanger mounted on top of the motor frame so cooling air is self contained and free of ambient air moisture and particulates. A second fan is mounted outside the motor housing to supply air to the heat exchanger.

Because they are capable of operating in either a clockwise or counter-clockwise direction (except 9500 frame), Baldor•Reliance TEAAC motors experience better rotor temperature stability and longer winding life. Tests have shown that unidirectionally cooled motors typically have at least 10 degrees C differential from one end of the core to the other. This results in higher temperatures for one end of the stator which potentially can limit motor life. This is one more example of Baldor's ability to find unique design solutions that yield reliable performance in tough applications.

### Energy Efficient 460 or 575 Volts, 60 Hz, 1.0 SF

Hp	kW	RPM			
		3600	1800	1200	900
400	298	E5808	—	—	—
450	336	E5808	—	—	E5810
500	373	E5808	—	E5810	E5810
600	448	E5808	E5808	E5810	E5810
700	522	E5808	E5810	E5810	E5812
800	600	E5808	E5810	E5812	E5812
900	671	E5810	E5810	E5812	—
1000	746	—	—	—	—
1250	933	—	—	—	—

**Note:** Data subject to change without notice.  
Contact a Baldor office for latest capabilities.

## TEAAC – Totally Enclosed Air to Air Cooled

### Standard Frame Selections

#### Energy Efficient 2300 or 4000 Volts, 60 Hz, 1.15 SF

Hp	kW	RPM			
		3600	1800	1200	900
400	298	E5808	—	—	—
450	336	E5808	—	—	E5810
500	373	E5808	—	E5810	E5810
600	448	E5808	E5808	E5810	E5810
700	522	E5808	E5810	E5810	E5812
800	600	E5808	E5810	E5812	E5812 (1)
900	671	E5810	E5810	E5812 (1)	6811
1000	746	E5810	E5810	E5812 (1)	6811 (1)
1250	932	6811	E5812	6813	—
1500	1119	6811	6811	6813	—
1750	1305	6811	6811 (1)	—	—
2000	1492	6811	—	—	—
2250	1678	6811 (1)	—	—	—

#### Energy Efficient 6600 Volts, 60 Hz, 1.15 SF

Hp	kW	RPM		
		3600	1200	900
900	671	—	—	6811 (1)
1000	746	6811	—	6811
1250	932	6811	6813	—
1500	1119	6811	6813	—
1750	1305	6811	—	—
2000	1492	6811 (1)	—	—
2250	1678	6811	—	—

**Note:** (1) Standard for I-O SF only.

Sleeve bearings required. Data subject to change without notice.  
Contact a Baldor office for latest capabilities.

# Explosion Proof Motors – Div 1, Class I, Group C & D

## Standard Frame Selections

Baldor•Reliance Explosion Proof Motors are designed for long life in the unique and challenging environment that combines a volatile gaseous or vapor atmosphere even when salt water conditions are a factor. Baldor•Reliance explosion proof motors operate worldwide in petro-chemical applications such as drill rig service, bulk fuel terminals and transfer stations. Baldor•Reliance is also highly regarded in critical process industries including above and below ground mining as well as grain storage and conveyance.



ABB hazardous duty motors are available with ATEX approval.

## Energy Efficient 460 or 575 Volts, 60 Hz, 1.0 SF

Hp	kW	RPM			
		3600	1800	1200	900
150	112	E449	E449	E449	E5010
200	150	E449	E449	E5010	E5010
250	187	E5010	E5010	E5010	E5810
300	224	E5010	E5010	E5810	E5810
350	261	E5010	E5010	E5810	E5810
400	298	E5010	E5010	E5810	E5810
450	336	E5010	E5810	E5810	E5810
500	373	—	E5810	E5810	E5810 *
600	448	—	E5810	E5810	—
700	522	—	E5810	E5810 *	—
800	600	—	E5810 *	—	—

**Note:** Data subject to change without notice.  
Additional explosion proof and hazardous duty motors are available. Contact a Baldor office for latest capabilities.  
\* Denotes copper bar rotor

## Energy Efficient 6600 Volts, 60 Hz, 1.0 SF

Hp	kW	RPM			
		3600	1800	1200	900
250	187	E5010	E5010	E5810	E5810
300	224	E5010	E5010	E5810	E5810
350	261	E5010	E5010	E5810	E5810
400	298	—	E5810	E5810	E5810
450	336	—	E5810	E5810	—
500	373	—	E5810	—	—

# Typical Performance Data – General Purpose Motors

## TEFC Energy Efficient 460 Volts, 3 Phase, 60 Hz, 1.15 SF

Hp	kW	RPM	Frame	Amps @ 460V		Rated Torque Lb. Ft.	Efficiency %			Power Factor %		
				Full Load	Locked Rotor		1/2	3/4	Full Load	1/2	3/4	Full Load
200	149	1790	G5008	239	1512	586	92.8	94.1	94.5	70.1	79.1	83
		1193	G5008	234	1468	881	93.2	94.3	94.5	74.5	82	84.9
		894	G5008	259	1430	1174	94	94.8	94.8	60.3	71	76.2
250	187	3576	G5008	284	1920	367	91.14	93	93.7	76.8	84.9	88.1
		1790	G5008	304	1854	733	93.2	94.4	94.7	66.4	76.9	81.3
		1193	G5008	291	1896	1100	93.7	94.7	94.8	74.1	81.9	84.9
		894	G5008	318	1672	1469	94.6	95.1	95	62.8	72.8	77.4
300	224	3575	G5008	332	2174	441	92.2	93.7	94.2	80.7	87.4	89.8
		1788	G5008	347	1953	881	94.4	95.2	95.2	75.2	82.8	85.1
		1193	G5008	351	2408	1320	94.4	95.1	95.2	71.8	80.4	84
		894	G5010	378	2040	1762	94.8	95.3	95.2	63.9	73.7	78.1
350	261	3575	G5008	382	2544	514	93	94.3	94.7	82	88.3	90.4
		1790	G5008	404	2557	1027	94.7	95.5	95.5	73.6	82	85
		1193	G5010	399	2516	1541	94.8	95.4	95.3	77.2	83.8	86.1
		894	G5010	450	2506	2055	94.9	95.4	95.3	60.9	71.5	76.4
400	298	3574	G5008	439	2793	588	92.9	94.2	94.5	81.6	88.1	90.2
		1790	G5008	465	2883	1173	94.9	95.6	95.6	73	81.1	84.3
		1193	G5010	455	2887	1761	95	95.6	95.5	77.6	84	86.3
		894	G5012	501	2728	2349	95.2	95.6	95.4	64.5	74.1	78.4
450	336	3575	G5010	494	3214	661	93.4	94.5	94.8	80.9	87.7	90
		1790	G5008	515	3138	1320	95.3	95.8	95.8	75.7	82.8	85.4
		1193	G5012	511	3407	1980	95.1	95.6	95.5	76.8	83.7	86.3
		895	G5012	580	3338	2642	95	95.5	95.4	60.2	71	76.2
500	373	3576	G5010	545	3628	734	93.8	94.8	95	81.4	88.1	90.3
		1790	G5010	574	3757	1466	94.4	95.3	95.5	74.6	82.7	85.5
		1193	G5012	564	3653	2201	95.4	95.8	95.6	78.5	84.7	86.8
		897	G5012	670	3995	2929	94.6	95.5	95.7	53.6	66.1	73
600	448	3576	G5010	646	4336	881	94.5	95.3	95.4	84.1	89.3	91.2
		1790	G5010	675	4137	1760	95.1	95.7	95.7	79.2	85	87
		1195	G5012	667	4364	2637	95.4	95.9	95.9	79.6	85.8	87.8
700	522	1790	G5012	783	5087	2053	95.5	96	95.9	79.4	85.3	87.2
800	600	1790	G5012	892	5460	2347	95.7	96.1	96	80.5	85.9	87.5
900	671	1793	G5012	990	6762	2636	95.8	96.4	96.4	79.7	86.2	88.3

**Note:** If data is not shown, contact a Baldor office.  
Data subject to change without notice. Contact a Baldor office for latest capabilities.

## Typical Performance Data – General Purpose Motors

### TEFC Energy Efficient 2300 or 4000 Volts, 60 Hz, 1.15 SF

Hp	kW	RPM	Frame	Amps @ 2300V		Amps @ 4000V		Rated Torque Lb. Ft.	Efficiency %			Power Factor %		
				Full Load	Locked Rotor	Full Load	Locked Rotor		1/2	3/4	Full Load	1/2	3/4	Full Load
200	149	3575	G5008	46	294	26	169	294	89.2	91.6	92.5	76.5	84.3	87.4
		1789	G5008	47	293	27	168	587	92.5	93.8	94.1	73.4	81.8	85.1
		1192	G5008	47	289	27	166	881	92.7	93.8	93.9	74.2	81.7	84.7
		894	G5008	51	290	29	167	1173	93.1	94.2	94.3	61.5	72.9	78
250	187	3575	G5008	59	374	34	215	367	89.5	91.8	92.6	73	82.1	86
		1789	G5008	59	359	34	206	734	93.4	94.4	94.5	71.9	80.2	83.5
		1192	G5008	59	369	34	212	1101	93.4	94.2	94.3	74.1	81.7	84.6
		894	G5010	64	358	37	206	1468	94	94.7	94.6	63.1	73.2	77.7
300	224	3575	G5008	69	441	40	254	441	90.8	92.7	93.3	76.1	84.3	87.6
		1789	G5008	72	440	41	253	880	93.6	94.5	94.7	69.8	78.8	82.6
		1192	G5010	70	461	40	265	1321	93.8	94.6	94.6	73.7	81.6	84.6
		894	G5010	76	435	44	250	1762	94.4	95	94.8	63.8	73.7	78.4
350	261	3575	G5008	79	496	45	285	514	91.8	93.4	93.9	79	86.2	88.8
		1789	G5008	82	514	47	296	1027	94.3	95	95.1	72.2	80.5	83.8
		1192	G5010	81	518	47	298	1542	94.3	94.9	94.9	75.6	82.7	85.4
		894	G5012	89	524	51	301	2056	94.4	95	94.9	62.4	72.8	77.6
400	298	3578	G5010	90	592	52	340	588	92.4	93.8	94.2	77.4	85.3	88.3
		1789	G5008	93	589	53	339	1174	94.7	95.3	95.3	73.4	81.3	84.4
		1192	G5012	93	626	53	360	1761	94.4	95.1	95	74.8	82.3	85.2
		894	G5012	101	605	58	348	2350	94.6	95.1	95	63.1	73.3	78
450	336	3578	G5010	101	702	58	404	661	92.9	94.2	94.6	76.9	85.1	88.3
		1789	G5010	104	671	60	386	1320	93.9	94.8	95	74.3	82.4	85.1
		1192	G5012	103	688	59	396	1982	94.7	95.2	95.1	75.6	82.9	85.7
		894	G5012	114	684	66	393	2644	95	95.4	95.3	61.8	72.4	77.3
500	373	3577	G5010	111	750	64	431	734	93.4	94.5	94.8	79.5	86.8	89.4
		1789	G5010	115	723	66	416	1468	94.3	95.1	95.1	75.9	83.4	85.7
		1192	G5012	115	787	66	453	2201	95.1	95.6	95.4	75	82.5	85.3
		896	G5810	125	711	72	409	2931	94.7	95.4	95.4	62.9	73.8	78.8
600	448	3576	G5010	132	875	76	503	881	94.3	95.1	95.2	80.1	87.3	89.7
		1790	G5012	138	915	79	526	1760	94.7	95.4	95.4	75.6	82.8	85.5
		1195	G5012	136	953	78	548	2637	95	95.7	95.7	75.1	83.1	86.2
		894	G5810	149	727	86	418	3523	94.9	95.5	95.3	68	76.3	79.3
700	522	3581	G5810	156	969	90	557	1027	94.8	95.5	95.6	79.3	85.9	88.2
		1789	G5012	159	1056	91	607	2054	95.1	95.7	95.6	77.1	83.8	86.1
		1194	G5810	161	995	93	572	3079	95.2	95.7	95.7	75.3	82.4	85
		897	G5810	174	987	100	568	4099	94.8	95.6	95.8	64.1	74.2	78.6
800	600	3582	G5810	177	1122	102	645	1173	95.1	95.8	95.8	79.7	86	88.3
		1789	G5012	181	1182	104	680	2347	95.6	96	95.9	77.6	84.1	86.5
		1196	G5810	183	1163	105	669	3513	95.4	96.1	96.2	75.8	82.8	85.2
		898	G500S	194	1192	112	685	4681	94.7	95.6	95.9	67.5	76.9	80.7
900	671	3586	G5810	196	1231	113	708	1318	95.3	96.1	96.2	81.5	87.3	89.3
		1792	G5012	200	1353	115	778	2638	95.8	96.3	96.2	78.6	85.4	87.7
		1197	G500S	202	1308	116	752	3951	94.6	95.5	95.8	79.3	85.2	87
		898	G500S	216	1342	124	772	5266	95	95.8	96	68.4	77.6	81.2

**Note:** Data subject to change without notice. If data is not shown, contact a Baldor office. Contact a Baldor office for latest capabilities.

## Typical Performance Data – General Purpose Motors

### TEFC Energy Efficient 2300 or 4000 Volts, 60 Hz, 1.15 SF (continued)

Hp	kW	RPM	Frame	Amps @ 2300V*		Amps @ 4000V		Rated Torque Lb. Ft.	Efficiency %			Power Factor %		
				Full Load	Locked Rotor	Full Load	Locked Rotor		1/2	3/4	Full Load	1/2	3/4	Full Load
1000	746	3591	G500M	222	1394	128	802	1462	92.6	94.5	95.3	81.2	96.8	88.7
		1792	G5810	224	1341	129	771	2930	95.7	96.2	96.1	78	84.6	86.9
		1197	G500S	223	1438	128	827	4389	94.9	95.8	96	80.6	86	87.5
		897	G500M	238	1342	137	772	5853	95.6	96.2	96.2	71.2	79.1	81.9
1250	932	3592	G500M	274	1757	158	1010	1828	93.7	95.2	95.9	81.6	87.1	89
		1794	G5810	276	1704	159	980	3660	96.3	96.8	96.7	81.2	86.4	87.7
		1197	G500S	278	1752	160	1007	5486	95.6	96.3	96.3	80.8	86.1	87.4
		898	G500M	299	1812	172	1042	7314	95.5	96.2	96.4	69.3	78	81.4
1500	1119	3592	G500M	328	2181	189	1254	2194	94.6	95.8	96.3	80.9	86.8	88.9
		1796	G500M	335	2146	193	1234	4388	95.3	96.2	96.4	79.2	85.1	87
		1197	G500M	333	2290	191	1317	6581	95.7	96.3	96.4	79.6	85.6	87.4
1750	1305	1795	G500M	388	2369	223	1362	5119	95.8	96.5	96.6	80.9	86.1	87.4
		1197	G500M	388	2642	223	1519	7678	95.9	96.5	96.6	80.1	85.9	87.6
2000	1492	1796	G500M	441	2850	254	1639	5849	96.3	97	97.2	80	85.7	87.3
2250	1678	1796	G500M	498	3201	286	1841	6581	96.3	97	97.2	79.6	85.4	87.1

### ODP/WPI Energy Efficient 460 Volts, 60 Hz, 1.15 SF

Hp	kW	RPM	Frame	Amps @ 460V		Rated Torque Lb. Ft.	Efficiency %			Power Factor %			Bearings	
				Full Load	Locked Rotor		1/2	3/4	Full Load	1/2	3/4	Full Load	D.E.	O.D.E.
500	373	3550	E5008	532	3459	732	95.4	96	95.8	82	88	90	6217	6217
		1780	E5008	582	3381	1467	95.2	95.5	95.8	80	82	85	6222	6222
600	448	3550	E5010	652	4068	882	95.1	95.9	95.8	87	89	90	6217	6217
		1780	E5010	658	3476	1760	96.2	96.4	96.2	87	90	90	6222	6222

### ODP/WPI Energy Efficient, 2300 or 4000 Volts, 60 Hz, 1.15 SF

Hp	kW	RPM	Frame	Amps @ 4000V		Rated Torque Lb. Ft.	Efficiency %			Power Factor %			Bearings	
				Full Load	Locked Rotor		1/2	3/4	Full Load	1/2	3/4	Full Load	D.E.	O.D.E.
300	224	3560	E449	37	240	442	92.7	93.8	94.1	85	89	92	6314	6314
		1785	E449	38	224	883	94.1	94.6	94.5	82	87	89	6222	6222
400	298	3580	E449	49	557	587	94	94.8	95	84	88	90	6217	6217
		1790	E5008	52	329	1174	93.3	95.1	95	81	86	86	6222	6222
500	373	3580	E5008	61	401	735	95.2	95.6	95.4	85	88	90	6217	6217
		1790	E5008	64	427	1468	93.7	94.5	95	82	85	87	6222	6222
600	448	3580	E5010	72	462	881	94.7	95.5	95.8	84	88	90	6217	6217
		1790	E5010	76	416	1763	93.7	94.8	95.4	80	85	88	6222	6222

Note: Data subject to change without notice. If data is not shown, contact a Baldor office. Contact a Baldor office for latest capabilities.

## Typical Performance Data – General Purpose Motors

### ODP/WPI Energy Efficient 2300 or 4000 Volts, 60 Hz, 1.15 SF

Hp	kW	RPM	Frame	Amps @ 2300V		Amps @ 4000V		Rated Torque Lb. Ft.	Efficiency %			Power Factor %		
				Full Load	Locked Rotor	Full Load	Locked Rotor		1/2	3/4	Full Load	1/2	3/4	Full Load
200	150	3565	E447	49	262	28	151	295	91.4	92.9	93.1	67.2	77.8	82.4
		1780	E447	47	266	27	153	590	93.5	94.1	93.9	75.3	82.5	85.1
		1189	5006	46	296	26	170	883	92.5	93.4	93.4	78	84.4	86.7
		890	5006	51	273	29	157	1180	92.6	93.4	93.3	63.5	73.9	78.9
250	187	3567	E449	59	336	34	193	368	92.6	93.7	93.8	70.4	80.2	84.3
		1780	E449	57	337	33	194	738	94.3	94.7	94.4	78.3	84.5	86.5
		1189	5006	59	378	34	217	1104	92.1	93.2	93.3	73.1	81.2	84.5
		889	5008	66	339	38	195	1476	92.6	93.4	93.2	59.3	70.7	76.6
300	224	3566	E449	71	411	41	236	442	93	93.9	94	70.6	80.5	84.6
		1781	E449	68	421	39	242	885	94.6	94.9	94.6	79.3	85.2	87.1
		1186	5006	71	442	41	254	1328	92.8	93.5	93.3	72.2	80.8	84.3
		889	5010	75	391	43	225	1773	93.6	94	93.6	65.4	75.3	79.8
350	261	3568	E449	80	514	46	296	515	93.8	94.6	94.5	74.3	83.2	86.6
		1782	5006	79	489	45	281	1031	93.6	94.3	94.1	82.5	87.3	88.6
		1184	5008	83	483	48	278	1552	93.4	93.8	93.4	74.1	81.9	85
		888	5010	86	423	49	243	2071	94.2	94.3	93.8	69.7	78.2	81.6
400	298	3568	E449	90	579	52	333	589	94.4	95	94.8	77.3	85.1	87.9
		1778	5008	93	532	53	306	1181	94.1	94.6	94.4	74.8	82.5	85.5
		1186	5010	93	611	53	351	1771	93.9	94.3	94	75.6	83.1	86.1
		889	5012	98	547	56	315	2362	94.3	94.6	94.2	68	77.2	81.3
450	336	3571	5008	99	661	57	380	661	94.7	95.1	95	81.1	87	89.1
		1778	5008	105	592	60	340	1329	94.2	94.6	94.4	73.8	81.8	85
		1186	5010	103	699	59	402	1992	94.2	94.6	94.3	77.2	84.2	86.8
		889	5012	112	625	64	359	2657	94.1	94.5	94.1	65.7	75.7	80.3
500	373	3572	5008	115	738	66	424	735	94	94.8	94.8	74.4	82.6	86
		1778	5008	118	662	68	381	1476	94.1	94.6	94.3	71.8	80.5	84.1
		1186	5010	114	749	66	431	2215	94.5	94.7	94.3	78.8	85.2	87.4
		888	5012	121	644	70	370	2956	94.5	94.7	94.2	69.6	78.3	81.9
600	448	3571	5010	135	845	78	486	882	94.7	95.2	95.1	78.4	85.1	87.7
		1777	5010	138	813	79	467	1772	94.9	95.1	94.8	75.4	83	85.9
		1185	5012	135	888	78	511	2658	94.8	94.9	94.4	80.4	86.1	88
		888	5810	143	745	82	428	3547	94.9	94.9	94.4	71.3	79.6	83
700	522	3573	5010	157	1039	90	597	1028	94.8	95.4	95.3	78.2	85.1	87.8
		1776	5010	159	935	91	538	2069	95.2	95.3	94.9	78.1	84.8	87.1
		1185	5810	157	799	90	459	3102	94.7	94.8	94.4	81.5	86.8	88.4
		889	5810	166	918	95	528	4135	95.2	95.3	94.8	71.7	80	83.4
800	600	3577	5808	184	1022	106	588	1174	94.3	95.1	95.2	72.5	81.8	85.5
		1778	5012	181	1175	104	676	2361	95.4	95.5	95.2	76.7	84	86.9
		1186	5810	178	993	102	571	3541	95	95.2	94.8	81.3	86.8	88.7
		889	5812	188	1042	108	599	4727	95.4	95.4	94.9	72.6	80.6	83.8
900	671	3574	5810	198	1016	114	584	1322	95.1	95.6	95.5	82.2	87.4	89.1
		1777	5012	202	1286	116	739	2658	95.7	95.7	95.3	78.7	85.3	87.6
		1186	5810	201	1164	116	669	3982	95	95.2	94.9	80.1	86.2	88.3
		889	5812	215	1259	124	724	5312	95.2	95.4	94.9	69.3	78.5	82.5
1000	746	3575	5810	223	1213	128	697	1469	94.9	95.5	95.5	78.6	85.3	87.7
		1779	5808	226	1104	130	635	2952	94.9	95.1	94.8	80.2	85.8	87.5
		1186	5812	221	1318	127	758	4424	95.2	95.4	95	81.8	87.3	89.1
		888	5812	234	1290	135	742	5910	95.8	95.7	95.1	73.8	81.4	84.3

Note: Data subject to change without notice. If data is not shown, contact a Baldor office. Contact a Baldor office for latest capabilities.

# Typical Performance Data – General Purpose Motors

## ODP/WPI Energy Efficient 2300 or 4000 Volts, 60 Hz, 1.15 SF (continued)

Hp	kW	RPM	Frame	Amps @ 2300V		Amps @ 4000V		Rated Torque Lb. Ft.	Efficiency %			Power Factor %		
				Full Load	Locked Rotor	Full Load	Locked Rotor		1/2	3/4	Full Load	1/2	3/4	Full Load
1250	933	3575	5810	281	1495	162	860	1836	95.2	95.7	95.6	77.6	84.6	87.2
		1778	5810	276	1426	159	820	3691	95.6	95.6	95.2	83.4	87.9	89.1
		1187	5812	276	1700	159	978	5529	95.4	95.5	95.1	81.3	87	89
		893	5812	281	1629	162	937	7348	94.8	95.4	95.4	78.4	85.1	87.3
1500	1119	3580	5810	330	1771	190	1018	2200	95.1	95.8	95.9	81.7	87.2	88.8
		1780	5812	329	1915	189	1101	4423	95.8	95.9	95.5	82.9	87.9	89.4
		1191	5812	324	2079	186	1195	6617	95.2	95.7	95.5	86.5	90.1	90.9
		894	6811	334	1976	192	1136	8816	95.1	95.6	95.5	79.8	86	88
1750	1305	3584	5812	380	2302	219	1324	2564	95.7	96.3	96.4	82.3	87.8	89.6
		1780	5812	383	2339	220	1345	5159	95.9	96	95.6	82.5	87.8	89.5
		1190	6811	376	2355	216	1354	7721	95.5	95.8	95.6	87.3	90.5	91.1
2000	1492	3589	5812	439	2616	252	1504	2928	95.1	96.1	96.4	79	86	88.6
		1789	5812	440	2836	253	1631	5872	96.2	96.6	96.5	81.7	86.9	88.3
		1191	6813	429	2689	247	1546	8822	95.6	95.9	95.7	87.5	90.6	91.1
2250	1678	3587	5812	492	2719	283	1563	3296	95.3	96.3	96.5	80.1	86.5	88.7
		1790	6811	488	3218	281	1850	6603	96.3	96.7	96.6	84.3	88.5	89.5
2500	1865	3580	5812	531	3316	305	1907	3668	96.1	96.6	96.6	85.5	90	91.3
		1790	6811	539	3699	310	2127	7334	96.5	96.9	96.7	84.5	88.7	89.7
3000	2238	3580	6811	637	3547	366	2040	4401	96.4	96.9	96.9	86.3	90.2	91.1
		1789	6813	644	3919	370	2253	8807	97.1	97.2	96.9	87	89.8	90

## WPII Energy Efficient 2300 or 4000 Volts, 60 Hz, 1.15 SF

Hp	kW	RPM	Frame	Amps @ 2300V		Amps @ 4000V		Rated Torque Lb. Ft.	Efficiency %			Power Factor %		
				Full Load	Locked Rotor	Full Load	Locked Rotor		1/2	3/4	Full Load	1/2	3/4	Full Load
200	150	3572	5006	47	285	27	164	294	92.1	93.4	93.7	71.5	80.7	84.6
		1784	5006	46	289	26	166	588	91.6	93	93.2	77.2	84	86.5
		1189	5006	46	296	26	170	883	92.5	93.4	93.4	78	84.4	86.7
		890	5006	51	273	29	157	1180	92.6	93.4	93.3	63.5	73.9	78.9
250	187	3573	5006	58	382	33	220	367	92.7	93.9	94.1	71.7	81.1	85.1
		1785	5006	57	384	33	221	735	92.3	93.4	93.6	77.2	84.8	87.2
		1187	5006	58	374	33	215	1105	92.9	93.6	93.5	75.5	83	85.9
		889	5008	63	339	36	195	1476	93.4	94	93.7	64.9	75	79.7
300	224	3572	5006	68	443	39	255	441	93.8	94.6	94.6	77.6	85	87.8
		1782	5006	67	407	39	234	884	93.6	94.2	94	83.7	88	89
		1185	5006	70	424	40	244	1329	93.4	93.9	93.5	76.1	83.3	86
		890	5010	75	423	43	243	1770	93.8	94.2	94	65.4	75.5	80.1
350	261	3571	5006	79	509	45	293	514	93.9	94.7	94.7	75.9	84	87.1
		1783	5006	78	512	45	294	1030	93.8	94.5	94.3	82.9	87.7	89
		1186	5008	81	530	47	305	1549	93.7	94.2	93.9	75.4	83	86
		888	5012	84	428	48	246	2070	94.6	94.7	94.1	72.6	80.1	82.9
400	298	3566	5006	90	519	52	298	589	94.2	94.7	94.5	78.8	85.3	87.7
		1778	5008	93	532	53	306	1181	94.1	94.6	94.4	74.8	82.5	85.5
		1186	5010	91	617	52	355	1770	94.4	94.7	94.3	79.1	85.4	87.6
		889	5012	98	547	56	315	2362	94.3	94.6	94.2	68	77.2	81.3
450	336	3571	5008	99	661	57	380	661	94.7	95.1	95	81.1	87	89.1
		1778	5008	105	592	60	340	1329	94.2	94.6	94.4	73.8	81.8	85
		1185	5010	101	656	58	377	1994	94.7	94.8	94.3	80.9	86.4	88.1
		890	5012	111	644	64	370	2656	94.3	94.6	94.3	66.8	76.5	80.9

Note: Data subject to change without notice. If data is not shown, contact a Baldor office. Contact a Baldor office for latest capabilities.

## Typical Performance Data – General Purpose Motors

### WPII Energy Efficient 2300 or 4000 Volts, 60 Hz, 1.15 SF (continued)

Hp	kW	RPM	Frame	Amps @ 2300V		Amps @ 4000V		Rated Torque Lb. Ft.	Efficiency %			Power Factor %		
				Full Load	Locked Rotor	Full Load	Locked Rotor		1/2	3/4	Full Load	1/2	3/4	Full Load
500	373	3572	5008	115	738	66	424	735	94	94.8	94.8	74.4	82.6	86
		1778	5008	116	679	67	390	1476	94.5	94.9	94.6	74.2	82.2	85.4
		1186	5012	112	758	64	436	2214	94.7	94.8	94.3	81.5	86.8	88.5
600	448	3571	5010	135	845	78	486	882	94.7	95.2	95.1	78.4	85.1	87.7
		1777	5010	138	813	79	467	1772	94.9	95.1	94.8	75.4	83	85.9
		1186	5012	134	943	77	542	2656	94.9	95	94.6	80.7	86.4	88.3
700	522	888	5810	143	745	82	428	3547	94.9	94.9	94.4	71.3	79.6	83
		3573	5010	157	1039	90	597	1028	94.8	95.4	95.3	78.2	85.1	87.8
		1777	5012	157	979	90	563	2067	95.5	95.5	95.1	79.1	85.5	87.7
800	600	889	5810	166	918	95	528	4135	95.2	95.3	94.8	71.7	80	83.4
		3573	05808	184	980	106	564	1176	94.3	95.1	95.1	73.9	82.5	85.6
		1784	05808	186	995	107	572	2356	94.5	95	94.9	73.2	81.4	84.7
900	671	889	5812	188	1042	108	599	4727	95.4	95.4	94.9	72.6	80.6	83.8
		3567	05808	209	1109	120	638	1325	93.5	94.4	94.5	73.7	82.2	85.3
		1785	05808	210	1172	121	674	2649	94.6	95.1	95	72.6	81.1	84.7
1000	746	889	5812	215	1259	124	724	5312	95.2	95.4	94.9	69.3	78.5	82.5
		3565	05808	233	1165	134	670	1473	93.7	94.5	94.6	73.8	82.1	85.1
		1782	05808	228	1114	131	641	2949	95.3	95.5	95.1	77.8	84.2	86.3
1250	932	888	5812	225	1290	129	742	5910	95.8	95.7	95.1	73.8	81.4	84.3
		3574	05810	279	1544	160	888	1837	95.5	95.9	95.8	78.7	85.3	87.6
		1786	05810	288	1823	166	1048	3677	95.1	95.6	95.5	72.5	81.3	85.1
1500	1119	894	5812	282	1853	162	1065	7341	94.6	95.4	95.4	76	83.9	86.9
		3572	05810	332	1727	191	993	2205	95.8	96	95.8	80.8	86.5	88.2
		1788	05810	333	1970	191	1133	4408	96.2	96.5	95.7	83.8	89	88.1
1750	1305	1191	5812	337	2079	194	1195	6617	95.2	95.7	95.7	86.5	90.1	87
		894	6811	336	2170	193	1248	8810	94.9	95.6	95.6	77.7	85	87.6
		3580	05810	389	2189	224	1259	2568	95.8	96.3	96.2	78.5	85.3	87.5
2000	1492	1784	05812	384	2340	221	1346	5153	96.3	96.3	96	81.8	87.2	89
		1191	6811	374	2459	215	1414	7716	95.6	95.9	95.8	87.7	90.8	91.4
		3583	05812	430	2713	247	1560	2930	96.2	96.6	96.6	83.8	88.7	90.2
2250	1678	1784	05812	446	2731	256	1570	5889	95.9	96.1	95.8	78.6	85.3	87.7
		1191	6813	427	2729	246	1569	8820	96	96.2	95.9	87.8	90.9	91.4
		3582	05812	486	2935	279	1688	3299	96.2	96.6	96.5	83.6	88.5	89.9
2500	1865	1789	05812	487	3106	280	1786	6609	96.1	96.4	96.3	82	88.1	90
		3582	05812	543	3206	312	1843	3666	96.4	96.7	96.6	82.5	87.7	89.3
3000	2237	1790	6811	538	3565	309	2050	7336	96.8	97	96.8	85.2	89	89.8
		3580	6811	637	3547	366	2040	4401	96.4	96.9	96.9	86.3	90.2	91.1

## Variable Speed Superiority

As mentioned earlier, energy consumption is by far the biggest cost associated with electric motor ownership. With the potential to save more than half of the energy used, it's no surprise that adjustable speed drives (ASD's) operating with AC motors are now commonplace in industry. In addition to energy savings, motors powered by ASD's also deliver operational flexibility and superior performance in most applications. And because Baldor designs and manufactures both motors and drives, our years of experience in matching both motors and drives affords customers a unique value opportunity.

Not every Large AC Motor is a suitable motor for the variety of ASD's available in today's market. But, with zero tolerance for downtime and 24/7 production schedules, industrial customers expect predictable motor and ASD performance. With this in mind Baldor•Reliance motors for variable speed applications are engineered for reliable performance in the most demanding industrial conditions. These unique design capabilities have been nurtured over the years as Baldor engineers worked closely with customers in Petro-Chemical, Paper, Mining, Metals, Power Generation and HVAC industries to seek application specific solutions that exceed customer needs and expectations. And Baldor is no stranger to critical service applications, such as the totally enclosed explosion proof motors capable of continuous constant torque operation at zero speed found on Drill Rig Top Drive applications.

Before the motor is selected for a variable speed application, it's important to understand the following:

- Is this a variable or constant torque load?
- What is the minimum and maximum speed?
- What is the overload percent and time?

Even when the application appears to be routine, years of ASD experience have taught Baldor to be cautious when designing Large AC Inverter Duty Motors. The ability to meet these rigorous demands is achieved by designing the following attributes into every Duty Master Inverter Duty motor:

- Class II high strength shaft material to help offset fatigue created by instantaneous ripple torques
- True thermal capability where each VSD motor is designed to operate continuously at the lowest possible speed where reduced air flow can cause overheating
- An insulation system designed to handle the higher voltage stress caused by non sine wave power into the motor, including glass served wire and 3.5 p.u. (per unit) surge protection
- Power dense designs for applications where fast response to speed commands and high torque is required. Where size and space are important, these power dense designs can result in a motor that is up to three sizes below conventional NEMA Frame motors
- Insulated bearings on both ends of the motor to prevent shaft currents from damaging the motor bearings or driven equipment bearings

## Leadership in industrial power and control The combined strength of ABB and Baldor

### Matched Performance

To further ensure design integrity and optimum performance, the ACS 2000 drive and Baldor•Reliance motors have undergone a rigorous set of combined test in the Kings Mountain test facility, bringing the quality story full circle. Our Matched Performance products ensure performance predictability on every ABB/Baldor customer application.

### Single point of contact

The combined power of the ABB/Baldor drive and motor offering is geared to deliver on customer expectations. Together, we can deliver motor-drive solutions that support our customers technical and commercial needs, from quotation, through delivery and service, over the entire product life-cycle.

### Installation and commissioning

Proper installation and commissioning of the equipment, done by qualified and certified commissioning engineers, reduces start-up time, increases safety and reliability and decreases life cycle costs. In addition, operators can be given practical training by experienced specialists on site.

With its advanced software tools, such as the commissioning wizard, start-up of an ACS 2000 and Baldor•Reliance motor is fast and easy, which minimizes plant downtime.

### Training

We provide comprehensive training for our motors and drives products. A range of training programs is offered from basic tutorials to programs tailored to the customer's specific needs.

### Life cycle management

ABB's life cycle management model maximizes the value of the equipment and maintenance investment by maintaining high availability, eliminating unplanned repair costs and extending the lifetime of the system. Life cycle management services include:

- spare parts and product support throughout the life cycle
- maintenance contracts for improved reliability
- remote monitoring and advanced diagnostic tools
- functionality upgrades

### Global network, local presence

After-sales service is an integral part of providing the customer with a reliable and efficient motor drive system. The ABB Group of companies operates in more than 100 countries and has a worldwide network of service operations.

### Made in the USA

ABB's ACS 2000 drives and Baldor•Reliance motors are manufactured in the United States. Not only does that reduce delivery times and transportation costs, it also affords opportunities where content requirements demand locally produced products.

# Typical Dimensions *(Only use Certified Prints for Construction & Installation)*

## ODP / WPI 5000 Drawing 616160-002

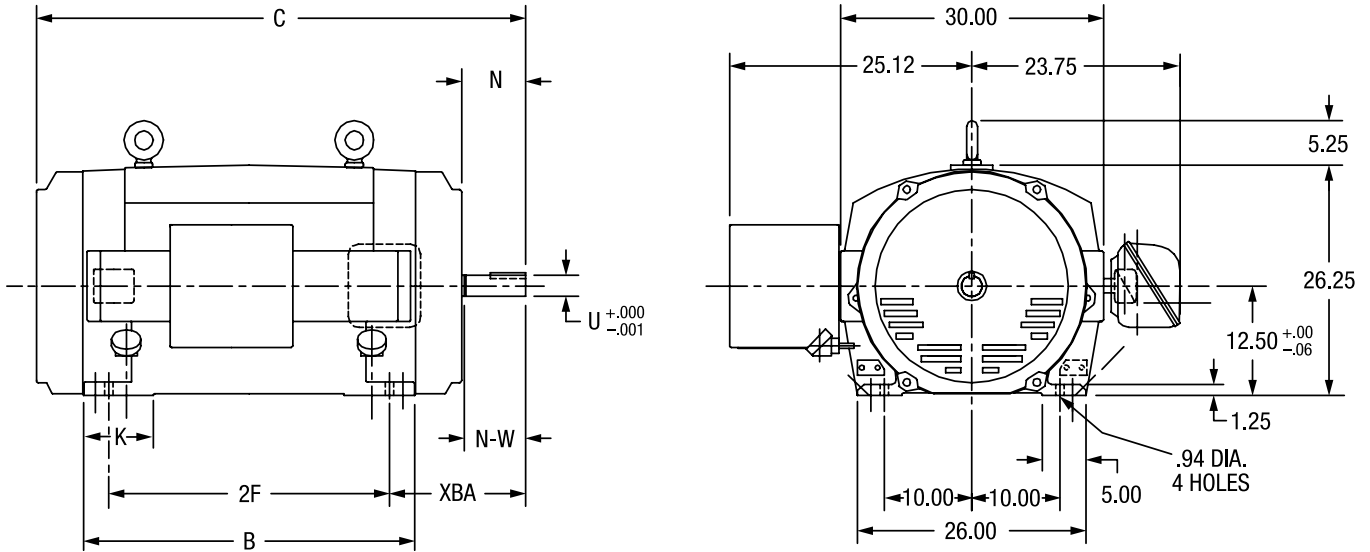

SEE DRAWING 616171-002 FOR CONDUIT BOX DIMENSIONS.

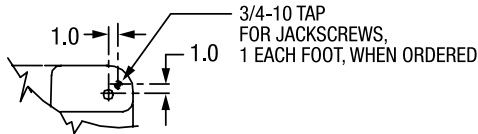

**BOTTOM VIEW OF FOOT**

Frame	Bearings	C	B	2F	K	XBA	N	N-W	U
5006Y	Anti Friction	47.75	25.75	20.00	10.00	19.50	11.25	11.00	3.75
5006Z	Anti Friction	43.75	25.75	20.00	10.00	15.50	7.25	7.00	4.13
5006S	Anti Friction	43.75	25.75	20.00	10.00	15.50	7.25	7.00	2.38
5008Y	Anti Friction	52.75	30.75	25.00	8.00	19.50	11.25	11.00	3.75
5008Z	Anti Friction	48.75	30.75	25.00	8.00	15.50	7.25	7.00	4.13
5008S	Anti Friction	48.75	30.75	25.00	8.00	15.50	7.25	7.00	2.38
5010Y	Anti Friction	59.75	37.75	32.00	11.50	19.50	11.25	11.00	3.75
5010Z	Anti Friction	55.75	37.75	32.00	11.50	15.50	7.25	7.00	4.13
5010S	Anti Friction	55.75	37.75	32.00	11.50	15.50	7.25	7.00	2.38
5012Y	Anti Friction	67.75	45.75	40.00	11.50	19.50	11.25	11.00	3.75
5012Z	Anti Friction	63.75	45.75	40.00	11.50	15.50	7.25	7.00	4.13
5006Z	Sleeve	43.88	25.75	20.00	10.00	15.50	7.12	7.00	3.63
5006S	Sleeve	43.88	25.75	20.00	10.00	15.50	7.12	7.00	2.88
5008Z	Sleeve	48.88	30.75	25.00	8.00	15.50	7.12	7.00	3.63
5008S	Sleeve	48.88	30.75	25.00	8.00	15.50	7.12	7.00	2.88
5010Z	Sleeve	55.88	37.75	32.00	11.50	15.50	7.12	7.00	3.63
5010S	Sleeve	55.88	37.75	32.00	11.50	15.50	7.12	7.00	2.88
5012Z	Sleeve	63.88	45.75	40.00	11.50	15.50	7.12	7.00	3.63

**Note:** Drawings shown are for reference only. Please contact Baldor for a detailed dimensional drawing of the specific motor you require. Dimensions are in inches. Drawings may also be available from our website at [www.baldor.com](http://www.baldor.com).

# Typical Dimensions *(Only use Certified Prints for Construction & Installation)*

## ODP / WPI E5800 Drawing 616160-004

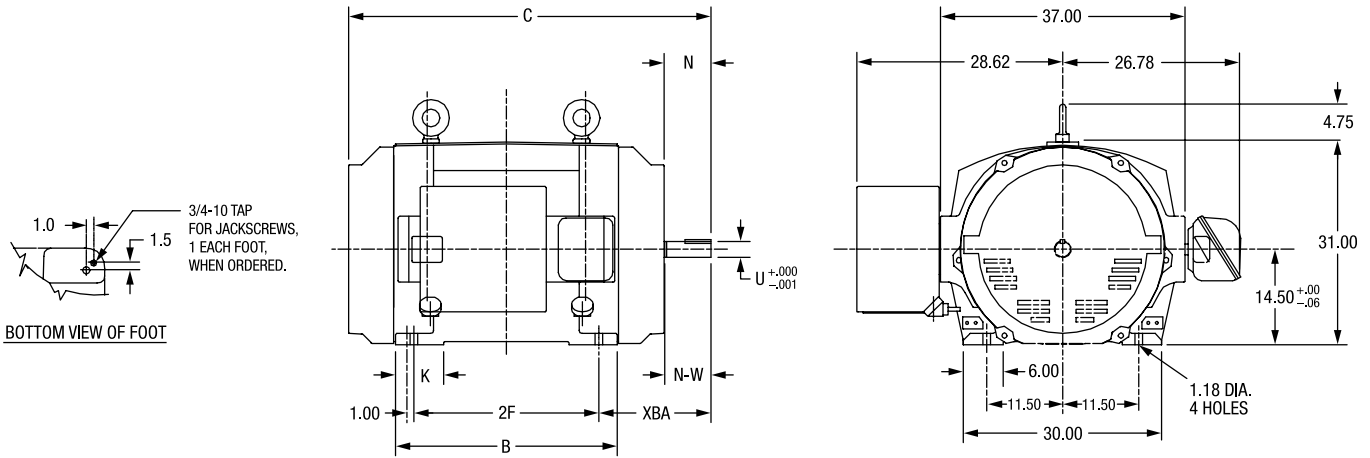

SEE DRAWING 616171-003 FOR CONDUIT BOX DIMENSIONS.

Frame	Bearings	C	B	2F	K	XBA	N	N-W	U
5808S	Anti Friction	54.88	33.50	28.00	9.50	17.00	7.12	6.75	4.50
5808	Anti Friction	58.88	33.50	28.00	9.50	21.00	11.12	10.75	4.50
5810S	Anti Friction	62.88	41.50	36.00	9.50	17.00	7.12	6.75	4.50
5810	Anti Friction	66.88	41.50	36.00	9.50	21.00	11.12	10.75	4.50
5812S	Anti Friction	71.88	45.00	45.00	9.50	17.00	7.12	6.75	4.50
5812	Anti Friction	75.88	45.00	45.00	9.50	21.00	11.12	10.75	4.50
5808S	Sleeve	54.75	33.50	28.00	9.25	17.00	7.25	7.00	3.63
5808S	Sleeve	54.75	33.50	28.00	9.25	17.00	7.25	7.00	2.88
5810S	Sleeve	62.75	41.50	36.00	9.25	17.00	7.25	7.00	3.63
5810S	Sleeve	62.75	41.50	36.00	9.25	17.00	7.25	7.00	2.88
5812S	Sleeve	71.75	50.50	45.00	9.25	17.00	7.25	7.00	4.50
5812S	Sleeve	71.75	50.50	45.00	9.25	17.00	7.25	7.00	3.63

## ODP / WPI O5800 Drawing 616160-014

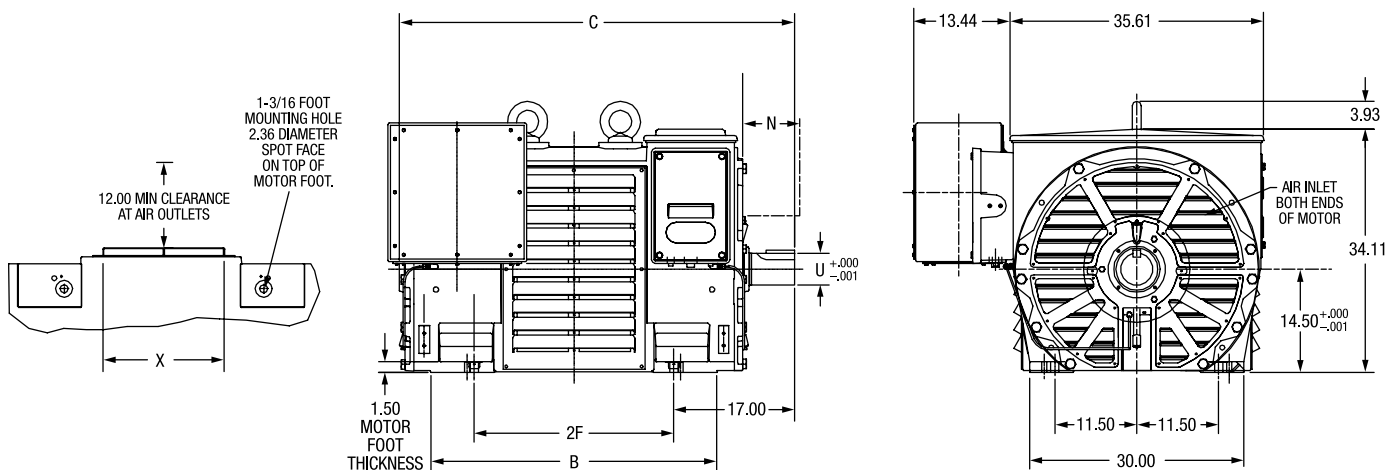

SEE DRAWING 616171-027 FOR TERMINAL BOX DIMENSIONS.

Frame	Bearings	C	B	2F	N	U	N
05808	Anti Friction	56.46	40.13	28.00	8.00	4.50	7.32
05810	Anti Friction	63.48	48.13	36.00	8.00	4.50	7.32
05812	Anti Friction	72.48	57.13	45.00	8.00	4.50	7.32
05808S	Sleeve	55.99	40.13	28.00	12.00	2.88	7.56
05810S	Sleeve	63.99	48.13	36.00	12.00	2.88	7.56
05812S	Sleeve	72.99	57.13	45.00	12.00	3.63	7.56

**Note:** Drawings shown are for reference only. Please contact Baldor for a detailed dimensional drawing of the specific motor you require. Dimensions are in inches. Drawings may also be available from our website at [www.baldor.com](http://www.baldor.com).

**Typical Dimensions** (Only use Certified Prints for Construction & Installation)

**WPII 05000**  
**Drawing 616161-001**

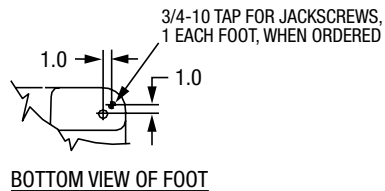
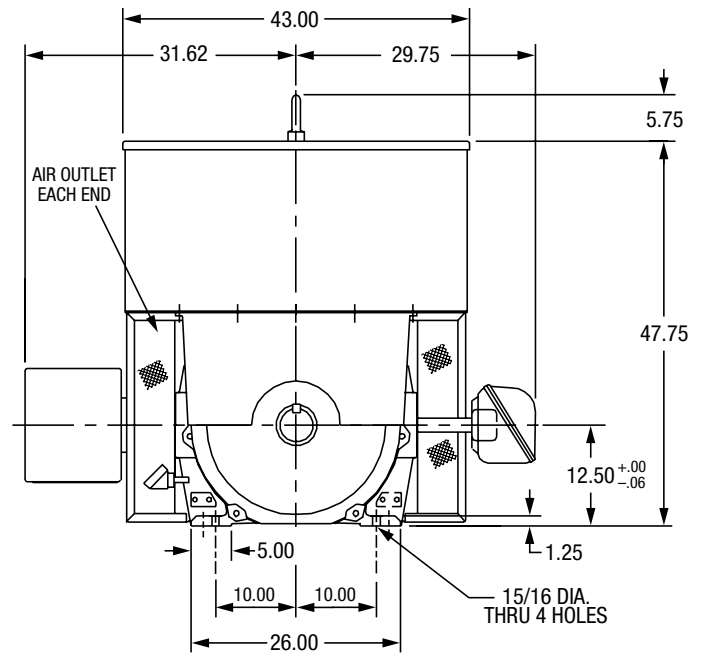
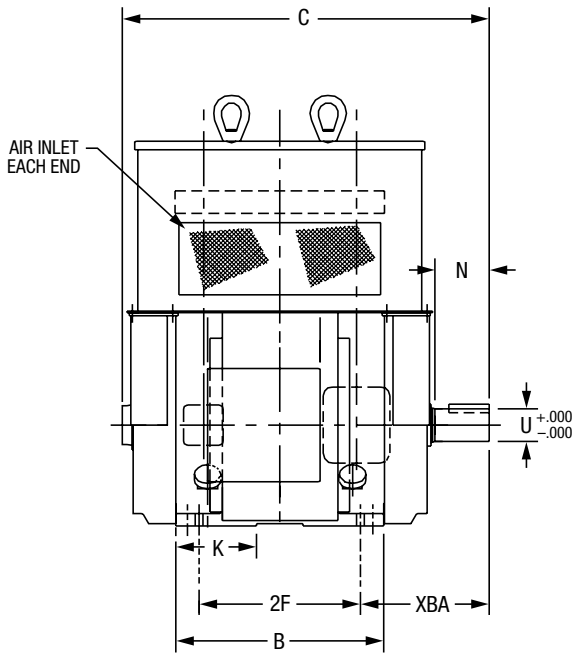

SEE DRAWING 616171-11 FOR CONDUIT BOX DIMENSIONS.

Frame	Bearings	C	B	2F	K	XBA	N	U
5006Y	Anti Friction	49.12	25.75	20.00	10.00	19.50	10.75	3.75
5006Z	Anti Friction	45.12	25.75	20.00	10.00	15.50	6.75	4.13
5006S	Anti Friction	45.12	25.75	20.00	10.00	15.50	6.75	2.38
5008Y	Anti Friction	54.12	30.75	25.00	8.00	19.50	10.75	3.75
5008Z	Anti Friction	54.12	30.75	25.00	8.00	15.50	6.75	4.13
5008S	Anti Friction	54.12	30.75	25.00	8.00	15.50	6.75	2.38
5010Y	Anti Friction	61.20	37.75	32.00	11.50	19.50	10.75	3.75
5010Z	Anti Friction	57.12	37.75	32.00	11.50	15.50	6.75	4.13
5010S	Anti Friction	57.12	37.75	32.00	11.50	15.50	6.75	2.38
5012Y	Anti Friction	69.12	45.75	40.00	11.50	19.50	10.75	3.75
5012Z	Anti Friction	69.12	45.75	40.00	11.50	15.50	6.75	4.13
5006Z	Sleeve	45.25	25.75	20.00	10.00	15.50	5.62	3.63
5006S	Sleeve	45.25	25.75	20.00	10.00	15.50	5.62	2.88
5008Z	Sleeve	50.25	30.75	25.00	8.00	15.50	5.62	3.63
5008S	Sleeve	50.25	30.75	25.00	8.00	15.50	5.62	2.88
5010Z	Sleeve	57.25	37.75	32.00	11.50	15.50	5.62	3.63
5010S	Sleeve	57.25	37.75	32.00	11.50	15.50	5.62	2.88
5012Z	Sleeve	65.25	45.75	40.00	11.50	15.50	5.62	3.63

**Note:** Drawings shown are for reference only. Please contact Baldor for a detailed dimensional drawing of the specific motor you require. Dimensions are in inches. Drawings may also be available from our website at [www.baldor.com](http://www.baldor.com).

# Typical Dimensions *(Only use Certified Prints for Construction & Installation)*

## WPII 05800 Drawing 616161-017

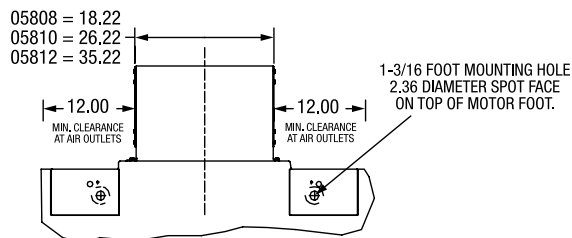
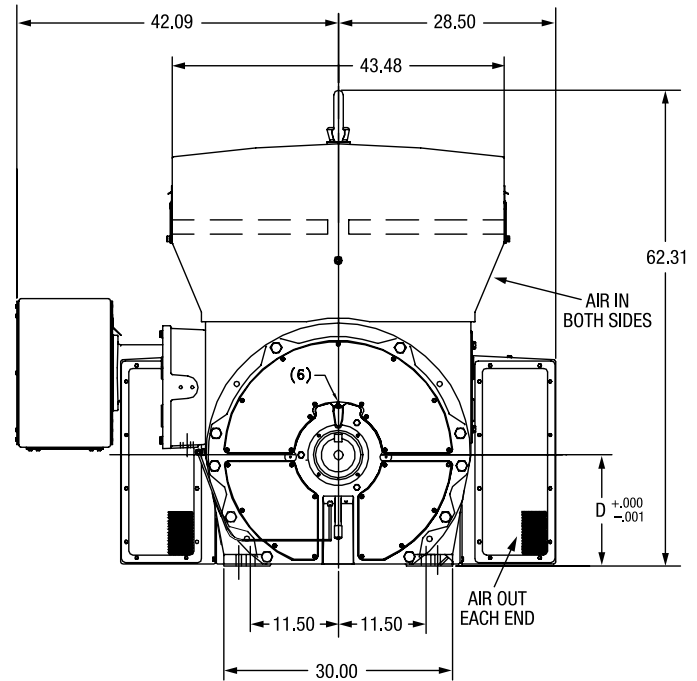
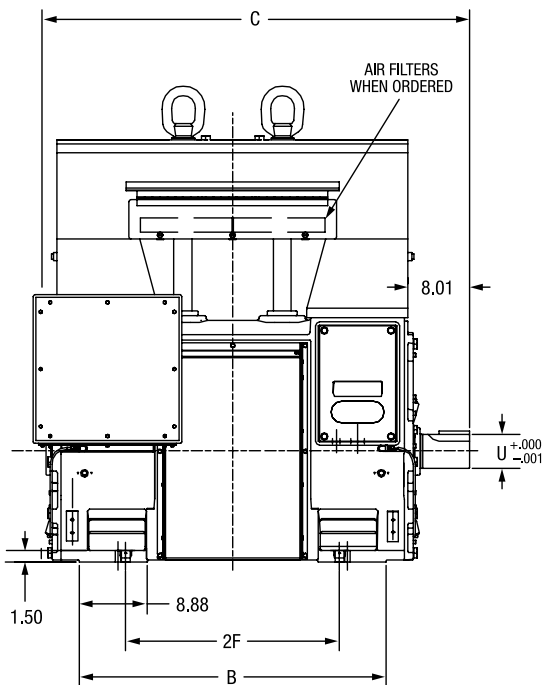

SEE DRAWING 616171-026 FOR CONDUIT BOX DIMENSIONS.

Frame	Bearings	C	B	2F	U
05808	Anti Friction	55.99	40.13	28.00	4.50
05810	Anti Friction	63.99	48.13	36.00	4.50
05812	Anti Friction	72.99	57.13	45.00	4.50
05808	Sleeve	58.50	40.13	28.00	2.88
05810	Sleeve	66.50	48.13	36.00	2.88
05812	Sleeve	75.50	57.13	45.00	2.88

**Note:** Drawings shown are for reference only. Please contact Baldor for a detailed dimensional drawing of the specific motor you require. Dimensions are in inches. Drawings may also be available from our website at [www.baldor.com](http://www.baldor.com).

# Typical Dimensions *(Only use Certified Prints for Construction & Installation)*

## TEFC 447 - 449 Drawing 616524-010

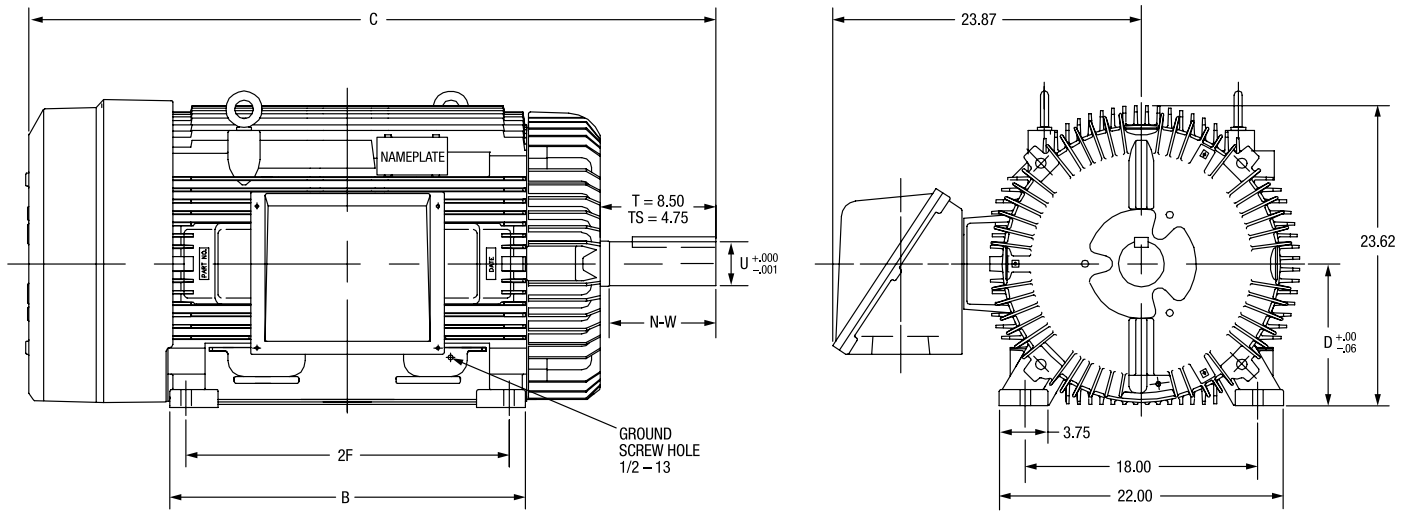

Frame	B	C	2F	U	N - W	D
447T	22.5	48.50	20.00	3.38	8.50	11.00
447TS	22.5	44.65	20.00	2.38	4.75	11.00
449T	27.5	53.40	25.00	3.38	8.50	11.00
449TS	27.5	49.65	25.00	2.28	4.75	11.00

**Note:** Drawings shown are for reference only. Please contact Baldor for a detailed dimensional drawing of the specific motor you require. Dimensions are in inches. Drawings may also be available from our website at [www.baldor.com](http://www.baldor.com).

## TEFC G5000 - Anti Friction Bearing Drawings 616868

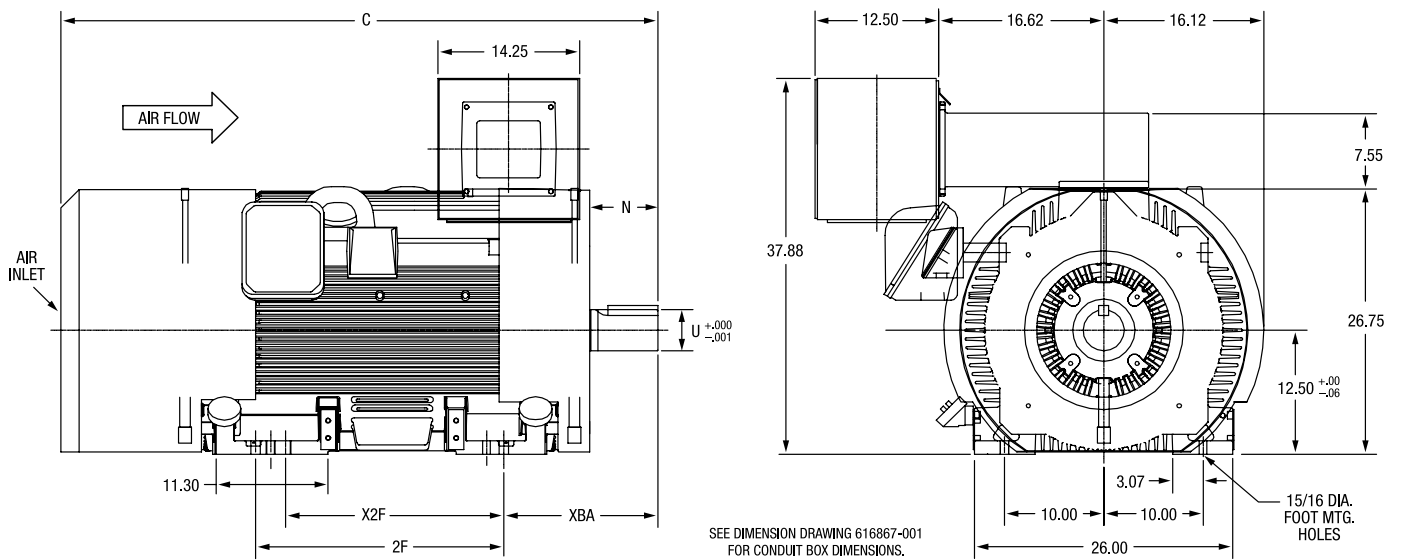

Drawing Number	Frame	Number of Poles	Bearings	C	Dual Foot Mount Holes		XBA	N	U
					2F	X2F			
616868-024	G5008S	2	Anti Friction	60.14	25.00	22.00	15.50	6.84	2.38
616868-017	G5008Y	4	Anti Friction	64.14	25.00	22.00	19.50	10.84	4.13
616868-022	G5010S	2	Anti Friction	67.14	32.00	28.00	15.50	6.84	2.38
616868-010	G5010Y	4	Anti Friction	71.14	32.00	28.00	19.50	10.84	4.13
616868-003	G5012Y	4	Anti Friction	79.14	40.00	36.00	19.50	10.84	4.13

# Typical Dimensions *(Only use Certified Prints for Construction & Installation)*

## TEFC G5000 – Sleeve Bearing Drawings 616868

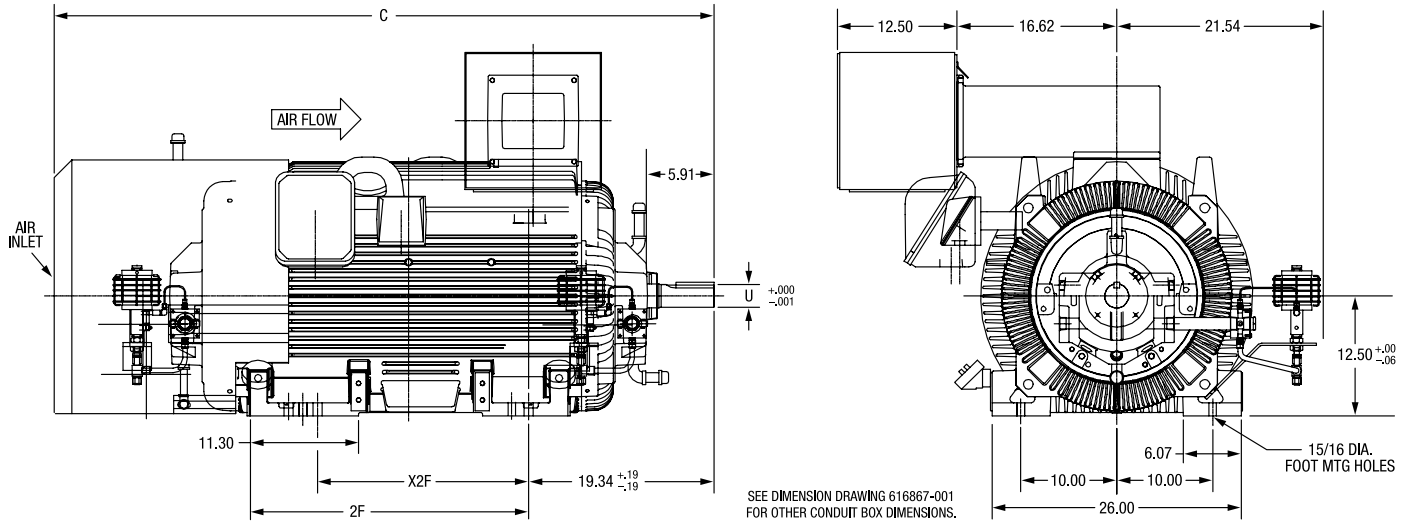

Drawing Number	Frame	Number of Poles	Bearing	C	Dual Foot Mount Holes		U
					2F	X2F	
616868-038	G5008S	2	Sleeve	68.79	25.00	22.00	2.38
616868-044	G5008Z	4	Sleeve	68.79	25.00	22.00	3.63
616868-036	G5010S	2	Sleeve	75.79	32.00	28.00	2.38
616868-042	G5010Z	4	Sleeve	75.79	32.00	28.00	3.63
616868-040	G5012Z	4	Sleeve	83.79	40.00	36.00	3.63

## TEFC G5800 Drawings 616164-024 and 616164-026

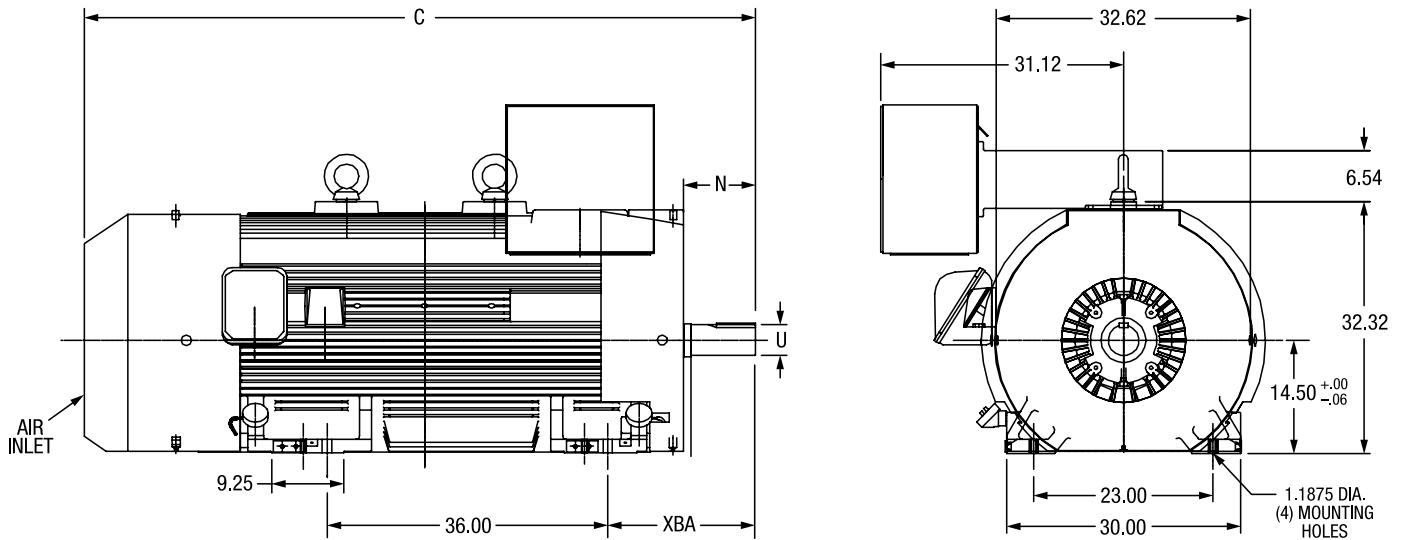

SEE DRAWING 616171-046 FOR CONDUIT BOX DIMENSIONS.

Drawing Number	Frame	Number of Poles	Bearing	C	N	U	XBA
616164-024	G5810S	2	Anti Friction	86.07	9.20	4.13	18.93
616164-024	G5810L	4	Anti Friction	90.81	13.94	4.13	23.68
616164-026	G5810S	2	Sleeve	88.00	4.5	2.38	17.00
616164-026	G5810Z	2	Sleeve	89.00	6.50	3.63	18.93

**Note:** Drawings shown are for reference only. Please contact Baldor for a detailed dimensional drawing of the specific motor you require. Dimensions are in inches. Drawings may also be available from our website at [www.baldor.com](http://www.baldor.com).

**Typical Dimensions** (Only use Certified Prints for Construction & Installation)

**TEFC G50**  
**Drawing 616164-019 and 616164-023**

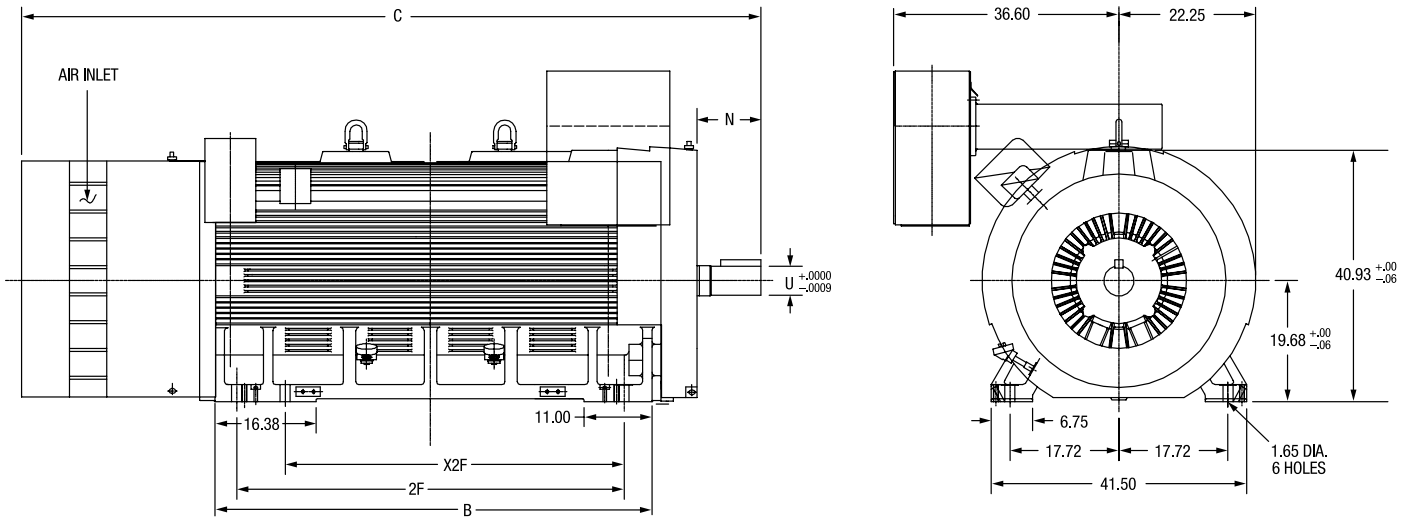

SEE DRAWING 616171-047 FOR CONDUIT BOX DIMENSIONS.

Drawing Number	Frame	Number of Poles	Bearings	C	B	Dual Foot Mount Holes		N	U
						2F	X2F		
616164-019	SG50	4	Anti Friction	106.44	57.25	49.21	39.37	10.38	4.73
616164-019	MG50	4	Anti Friction	120.18	71.00	62.99	55.12	10.38	4.73
616164-023	SG50	4	Sleeve	108.62	57.25	49.21	39.37	10.71	3.54
616164-023	MG50	4	Sleeve	122.37	71.00	62.99	55.12	10.71	3.54

**Note:** Drawings shown are for reference only. Please contact Baldor for a detailed dimensional drawing of the specific motor you require. Dimensions are in inches. Drawings may also be available from our website at [www.baldor.com](http://www.baldor.com).

# Typical Dimensions *(Only use Certified Prints for Construction & Installation)*

## TEAAC E5800 Drawing 616166-001 and 616166-002

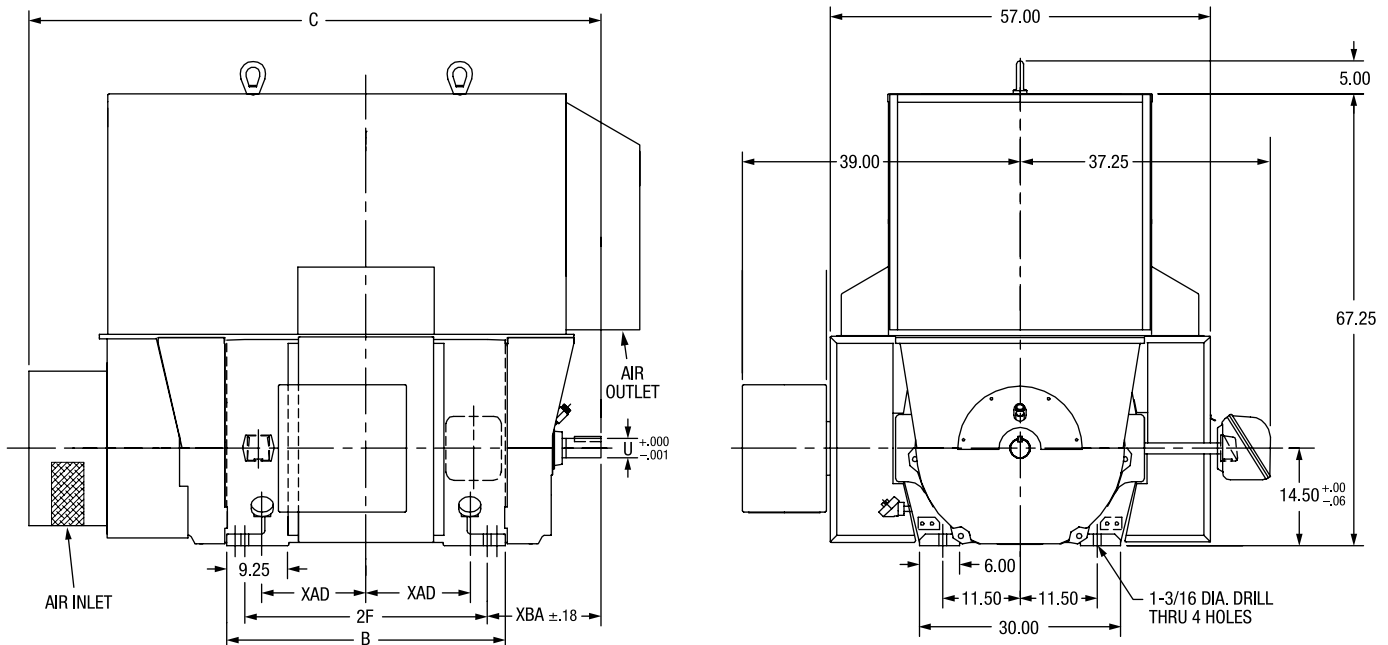

SEE DRAWING 616171-051 FOR CONDUIT BOX DIMENSIONS.

Drawing Number	Frame	Number of Poles	Bearings	C	B	2F	XAD	U	XBA
616166-001	E5808S	2	Anti Friction	78.00	33.50	28.00	11.50	4.50	17.00
616166-001	E5808S	2	Anti Friction	78.00	33.50	28.00	11.50	2.38	17.00
616166-001	E5808	4	Anti Friction	82.00	33.50	28.00	11.50	4.50	21.00
616166-001	E5810S	2	Anti Friction	86.00	41.50	36.00	15.50	4.50	17.00
616166-001	E5810S	2	Anti Friction	86.00	41.50	36.00	15.50	2.38	17.00
616166-001	E5910	4	Anti Friction	90.00	41.50	36.00	15.50	4.50	21.00
616166-001	E5912S	2	Anti Friction	95.00	50.50	45.00	20.00	4.50	17.00
616166-002	E5808S	2	Sleeve	78.00	33.50	28.00	11.50	3.63	17.00
616166-002	E5808S	2	Sleeve	78.00	33.50	28.00	11.50	2.88	17.00
616166-002	E5810S	2	Sleeve	86.00	41.50	36.00	15.50	3.63	17.00
616166-002	E5810S	2	Sleeve	86.00	41.50	36.00	15.50	2.88	17.00
616166-002	E5912S	2	Sleeve	95.00	50.50	45.00	20.00	4.50	17.00
616166-002	E5912S	2	Sleeve	95.00	50.50	45.00	20.00	3.63	17.00

**Note:** Drawings shown are for reference only. Please contact Baldor for a detailed dimensional drawing of the specific motor you require. Dimensions are in inches. Drawings may also be available from our website at [www.baldor.com](http://www.baldor.com).

# Typical Dimensions *(Only use Certified Prints for Construction & Installation)*

## EXPLOSION PROOF DIV I 440 Drawing 616525-035

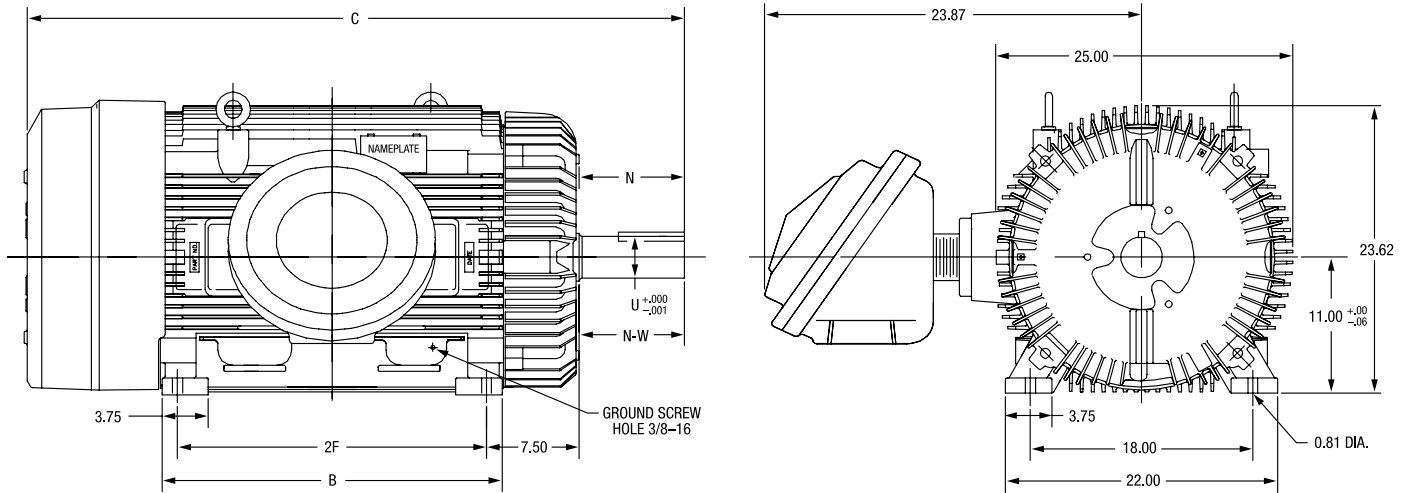

Frame	C	B	2F	N	N - W	U
447TY	48.40	22.50	20.00	8.50	8.50	3.88
447TZ	44.65	22.50	20.00	4.75	4.75	2.88
449TY	53.40	27.50	25.00	8.50	8.50	3.88
449TZ	49.65	27.50	25.00	4.75	4.75	2.88

## EXPLOSION PROOF DIV I 5000/5800 Drawings 616165-002 and 616165-004

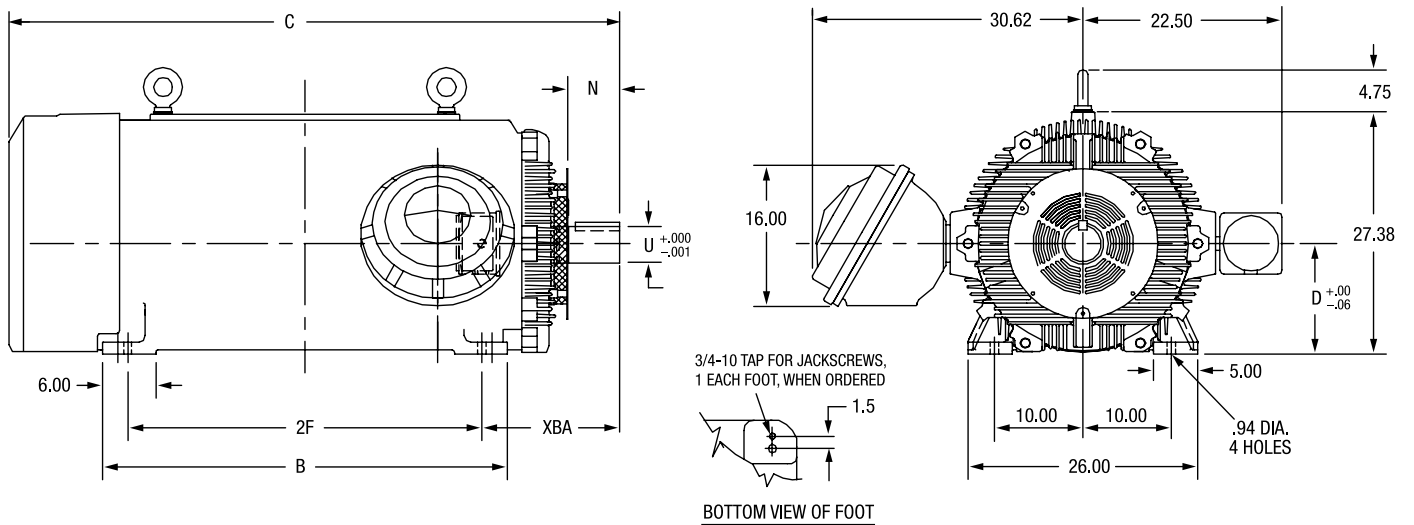

Frame	C	B	2F	U	XBA	D	N
5010Y	65.00	37.75	32.00	3.75	19.50	12.50	10.82
5010Z	61.00	37.75	32.00	4.13	15.50	12.50	6.82
5010S	61.00	37.75	32.00	2.38	15.50	12.50	6.82
5012Y	73.00	45.75	40.00	3.75	19.50	12.50	10.20
5010Z	69.00	37.75	40.00	4.13	15.50	12.50	6.20
5810	87.25	41.50	36.00	4.13	24.25	14.50	11.75
5810S	82.50	41.50	36.00	4.13	19.50	14.50	7.00

**Note:** Drawings shown are for reference only. Please contact Baldor for a detailed dimensional drawing of the specific motor you require. Dimensions are in inches. Drawings may also be available from our website at [www.baldor.com](http://www.baldor.com).

# Typical Dimensions *(Only use Certified Prints for Construction & Installation)*

## WPII 6811 2-Pole and 4-Pole *(See Bottom View below)* Drawings S101001-020 and S101001-021

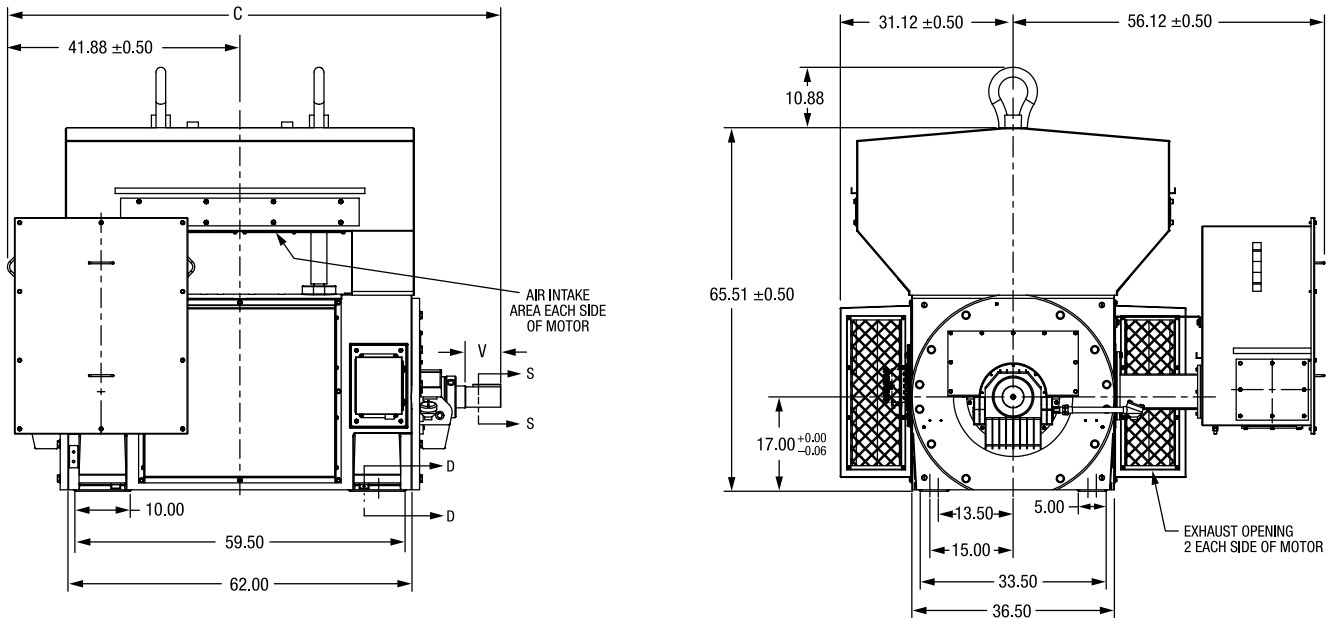

Drawing Number	Number of Poles	V	C
S101001-020	2-Pole	6.25	88.88
S101001-021	4 Pole and Slower	7.50	90.88

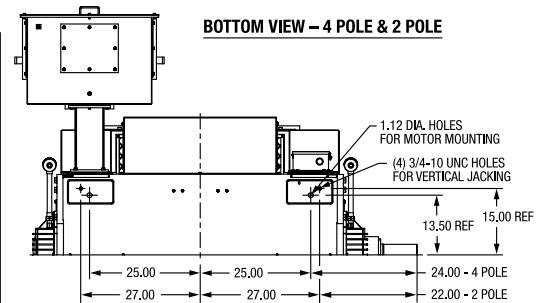
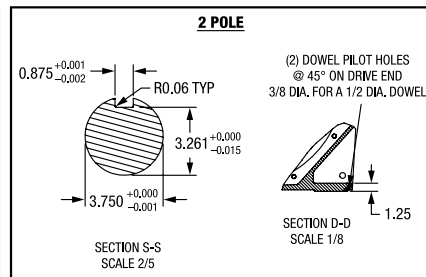
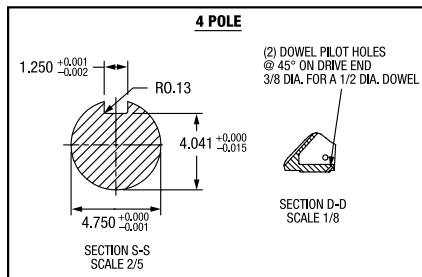

**Note:** Drawings shown are for reference only. Please contact Baldor for a detailed dimensional drawing of the specific motor you require. Dimensions are in inches. Drawings may also be available from our website at [www.baldor.com](http://www.baldor.com).

**Typical Dimensions** (Only use Certified Prints for Construction & Installation)

**WPII 6813 2-Pole and 4-Pole** (See Bottom View below)  
Drawings S101001-022 and S101001-023

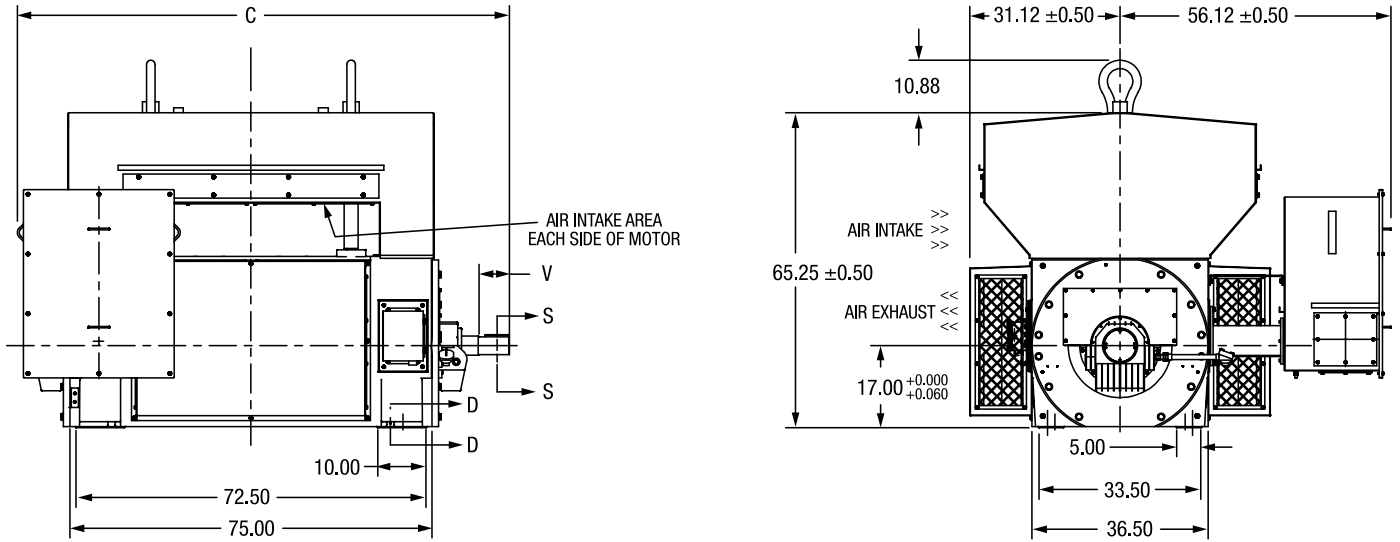

Drawing Number	Number of Poles	V	C
S101001-022	2-Pole	6.25	101.88
S101001-023	4 Pole and Slower	7.50	103.98

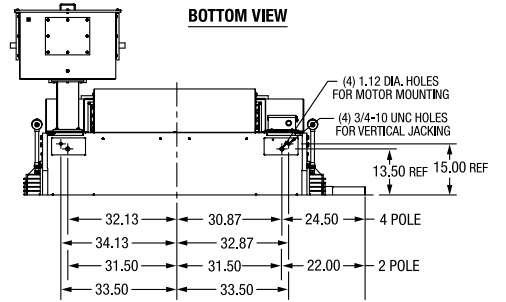
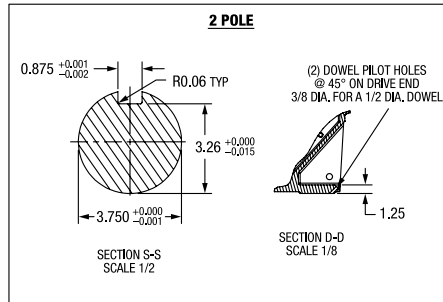
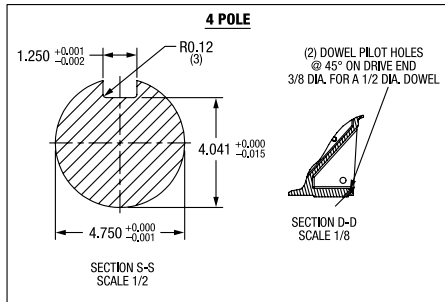

**Note:** Drawings shown are for reference only. Please contact Baldor for a detailed dimensional drawing of the specific motor you require. Dimensions are in inches. Drawings may also be available from our website at [www.baldor.com](http://www.baldor.com).

# Typical Dimensions *(Only use Certified Prints for Construction & Installation)*

## TEAAC 6811 2-Pole and 4-Pole *(See Bottom View below)* Drawings S101001-024 and S101001-025

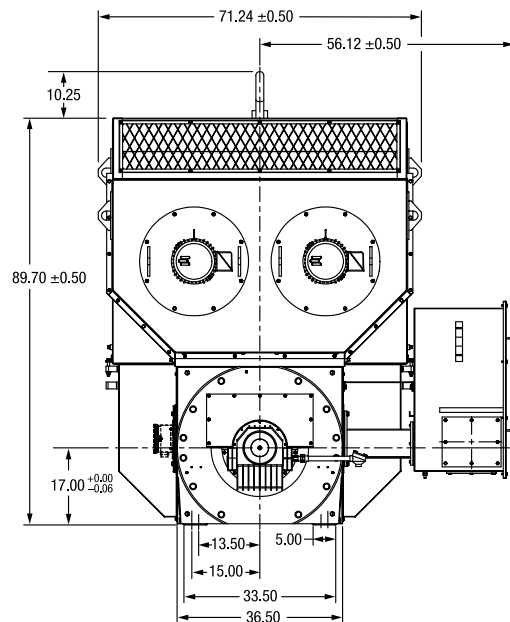
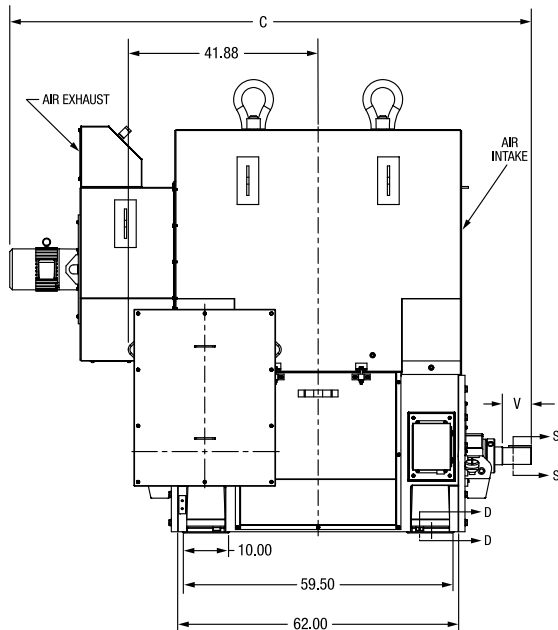

Drawing Number	Number of Poles	V	C
S101001-024	2-Pole	6.25	115.02
S101001-025	4 Pole and Slower	7.00	117.02

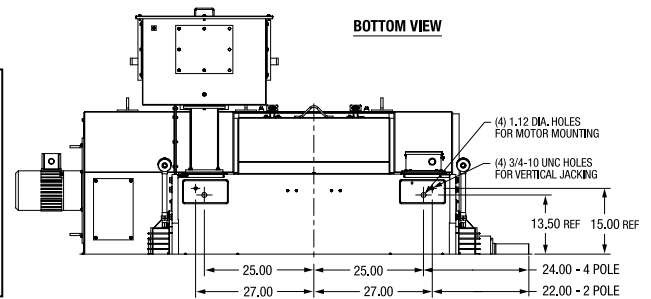
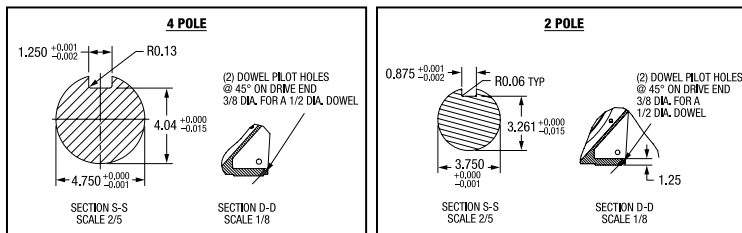

**Note:** Drawings shown are for reference only. Please contact Baldor for a detailed dimensional drawing of the specific motor you require. Dimensions are in inches. Drawings may also be available from our website at [www.baldor.com](http://www.baldor.com).

**Typical Dimensions** (Only use Certified Prints for Construction & Installation)

**TEAAC 6813 2-Pole and 4-Pole** (See Bottom View below)  
Drawings S101001-028 and S101001-029

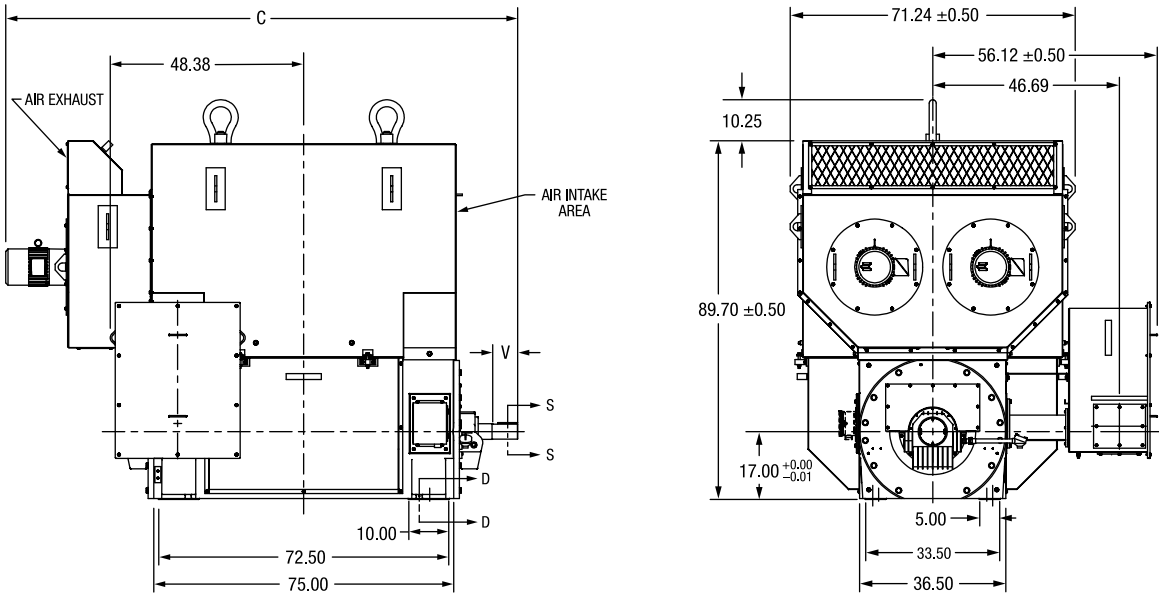

Drawing Number	Number of Poles	V	C
S101001-028	2-Pole	6.25	88.88
S101001-029	4 Pole and Slower	7.50	90.88

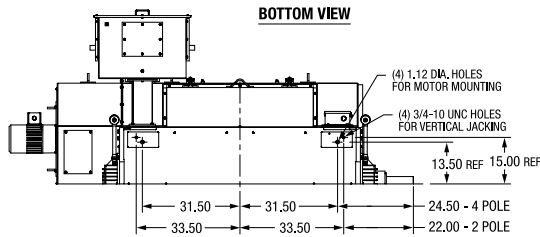
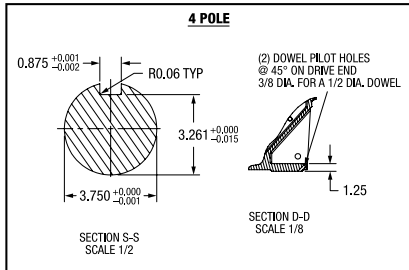
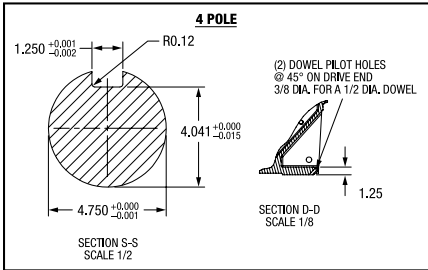

**Note:** Drawings shown are for reference only. Please contact Baldor for a detailed dimensional drawing of the specific motor you require. Dimensions are in inches. Drawings may also be available from our website at [www.baldor.com](http://www.baldor.com).

# Most Common Main Power Connection Diagrams for Baldor•Reliance Motors

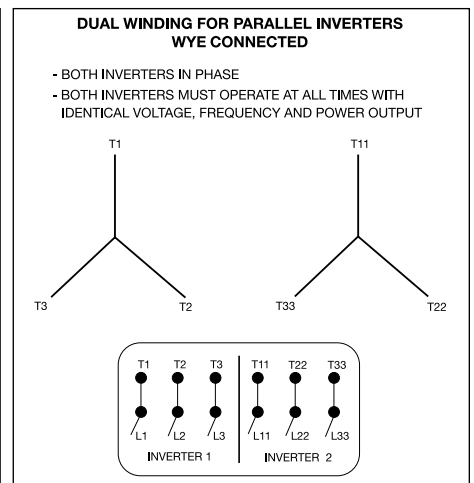
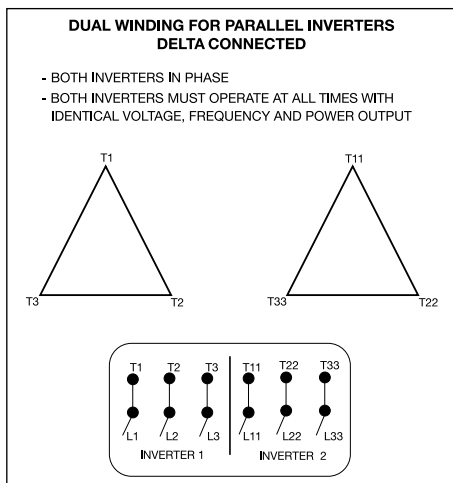
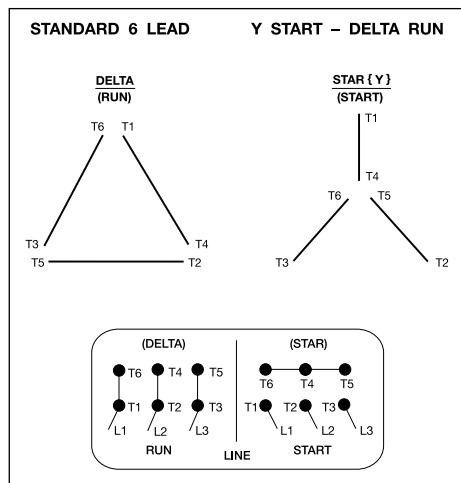
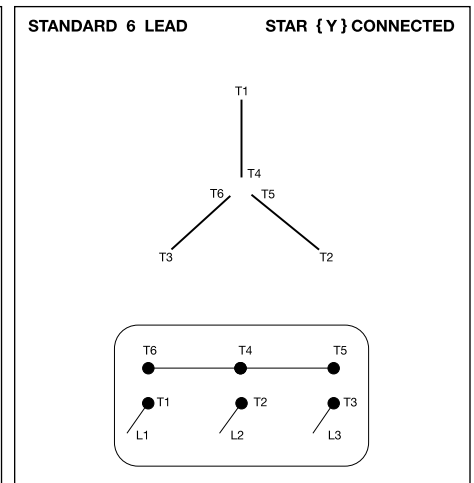
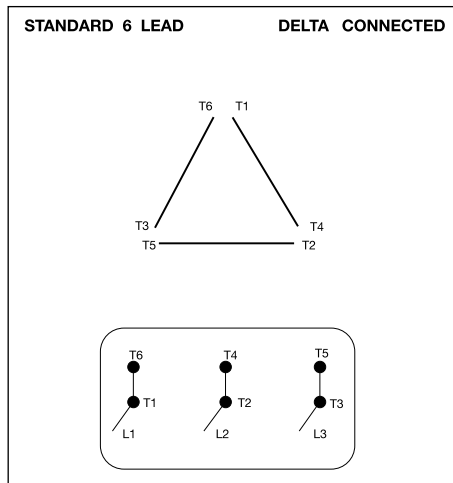
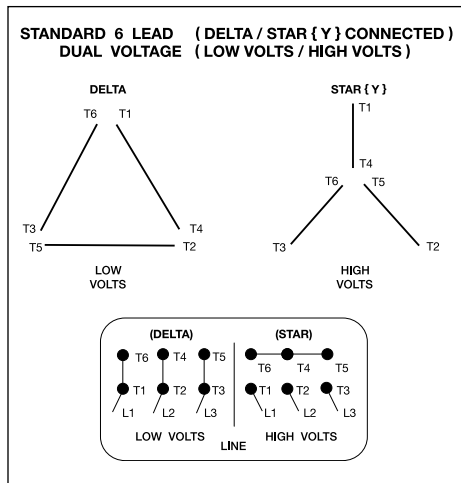
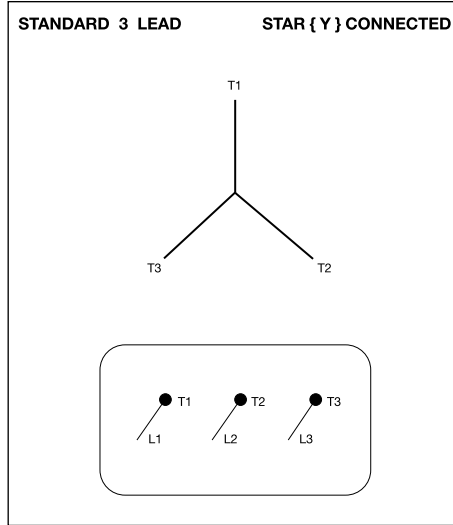
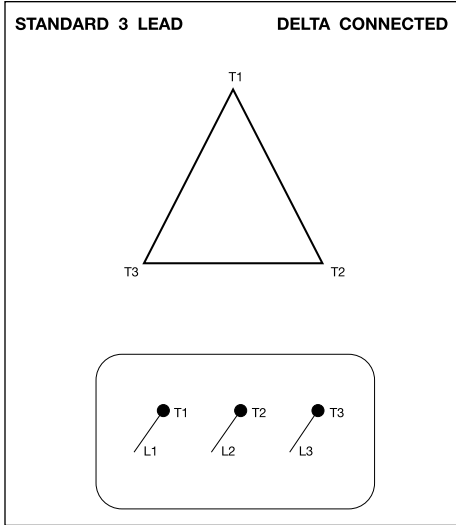

## Contact your nearest Baldor Sales Office at these World Wide Locations, or visit [www.baldor.com](http://www.baldor.com)

**UNITED STATES****ARIZONA**

**PHOENIX**  
4211 S 43RD PLACE  
PHOENIX, AZ 85040  
PHONE: 602-470-0407  
FAX: 602-470-0464

**ARKANSAS**

**CLARKSVILLE**  
706 WEST MAIN STREET  
CLARKSVILLE, AR 72830  
PHONE: 479-754-9108  
FAX: 479-754-9205

**CALIFORNIA**

**LOS ANGELES**  
6480 FLOTTILLA STREET  
COMMERCE, CA 90040  
PHONE: 323-724-6771  
FAX: 323-721-5859

**HAYWARD**

21056 FORBES STREET  
HAYWARD, CA 94545  
PHONE: 510-785-9900  
FAX: 510-785-9910

**COLORADO**

**DENVER**  
3855 FOREST STREET  
DENVER, CO 80207  
PHONE: 303-623-0127  
FAX: 303-595-3772

**CONNECTICUT**

**WALLINGFORD**  
65 SOUTH TURNPIKE ROAD  
WALLINGFORD, CT 06492  
PHONE: 203-269-1354  
FAX: 203-269-5485

**FLORIDA**

**TAMPA/PUERTO RICO/  
VIRGIN ISLANDS**  
3906 EAST 11TH AVENUE  
TAMPA, FL 33605  
PHONE: 813-248-5078  
FAX: 813-241-9514

**GEORGIA**

**ATLANTA**  
62 TECHNOLOGY DRIVE  
ALPHARETTA, GA 30005  
PHONE: 770-772-7000  
FAX: 770-772-7200

**ILLINOIS**

**CHICAGO**  
340 REMINGTON BLVD.  
BOLINGBROOK, IL 60440  
PHONE: 630-296-1400  
FAX: 630-226-9420

**INDIANA**

**INDIANAPOLIS**  
5525 W. MINNESOTA STREET  
INDIANAPOLIS, IN 46241  
PHONE: 317-246-5100  
FAX: 317-246-5110

**IOWA**

**DES MOINES**  
1943 HULL AVENUE  
DES MOINES, IA 50313  
PHONE: 515-263-6929  
FAX: 515-263-6515

**MARYLAND**

**BALTIMORE**  
6660 SANTA BARBARA RD.  
SUITES 22-24  
ELKRIDGE, MD 21075  
PHONE: 410-579-2135  
FAX: 410-579-2677

**MASSACHUSETTS**

**BOSTON**  
6 PULLMAN STREET  
WORCESTER, MA 01606  
PHONE: 508-854-0708  
FAX: 508-854-0291

**MICHIGAN**

**DETROIT**  
5993 PROGRESS DRIVE  
STERLING HEIGHTS, MI 48312  
PHONE: 586-978-9800  
FAX: 586-978-9969

**MINNESOTA**

**MINNEAPOLIS**  
13098 GEORGE WEBER DR,  
SUITE 400  
ROGERS, MN 55374  
PHONE: 763-428-3633  
FAX: 763-428-4551

**MISSOURI**

**ST LOUIS**  
13678 LAKEFRONT DRIVE  
EARTH CITY, MO 63045  
PHONE: 314-373-3032  
FAX: 314-373-3038

**KANSAS CITY**

1501 BEDFORD AVENUE  
NORTH KANSAS CITY, MO 64116  
PHONE: 816-587-0272  
FAX: 816-587-3735

**NEW YORK**

**AUBURN**  
ONE ELLIS DRIVE  
AUBURN, NY 13021  
PHONE: 315-255-3403  
FAX: 315-253-9923

**NORTH CAROLINA**

**GREENSBORO**  
1220 ROTHERWOOD ROAD  
GREENSBORO, NC 27406  
PHONE: 336-272-6104  
FAX: 336-273-6628

**OHIO**

**CINCINNATI**  
2929 CRESCENTVILLE ROAD  
WEST CHESTER, OH 45069  
PHONE: 513-771-2600  
FAX: 513-772-2219

**CLEVELAND**

8929 FREEWAY DRIVE  
MACEDONIA, OH 44056  
PHONE: 330-468-4777  
FAX: 330-468-4778

**OKLAHOMA**

**TULSA**  
5555 E. 71ST ST., SUITE 9100  
TULSA, OK 74136  
PHONE: 918-366-9320  
FAX: 918-366-9338

**OREGON**

**PORTLAND**  
12651 SE CAPPS ROAD  
CLACKAMAS, OR 97015  
PHONE: 503-691-9010  
FAX: 503-691-9012

**PENNSYLVANIA**

**PHILADELPHIA**  
1035 THOMAS BUSCH  
MEMORIAL HIGHWAY  
PENNSAUKEN, NJ 08110  
PHONE: 856-661-1442  
FAX: 856-663-6363

**PITTSBURGH**

159 PROMINENCE DRIVE  
NEW KENSINGTON, PA 15068  
PHONE: 724-889-0092  
FAX: 724-889-0094

**TENNESSEE**

**MEMPHIS**  
4000 WINCHESTER ROAD  
MEMPHIS, TN 38118  
PHONE: 901-365-2020  
FAX: 901-365-3914

**TEXAS**

**DALLAS**  
2920 114TH STREET SUITE 100  
GRAND PRAIRIE, TX 75050  
PHONE: 214-634-7271  
FAX: 214-634-8874

**HOUSTON**

10355 W. LITTLE YORK ROAD  
SUITE 300  
HOUSTON, TX 77041  
PHONE: 281-977-6500  
FAX: 281-977-6510

**UTAH**

**SALT LAKE CITY**  
2230 SOUTH MAIN STREET  
SALT LAKE CITY, UT 84115  
PHONE: 801-832-0127  
FAX: 801-832-8911

**WISCONSIN**

**MILWAUKEE**  
1960 SOUTH CALHOUN ROAD  
NEW BERLIN, WI 53151  
PHONE: 262-784-5940  
FAX: 262-784-1215

**INTERNATIONAL SALES**

**FORT SMITH, AR**  
P.O. BOX 2400  
FORT SMITH, AR 72902  
PHONE: 479-646-4711  
FAX: 479-648-5895

**CANADA**

**EDMONTON, ALBERTA**  
4053-92 STREET  
EDMONTON, ALBERTA T6E 6R8  
PHONE: 780-434-4900  
FAX: 780-438-2600

**TORONTO**

**OAKVILLE, ONTARIO**  
2750 COVENTRY ROAD  
OAKVILLE, ONTARIO L6H 6R1  
PHONE: 905-829-3301  
FAX: 905-829-3302

**MONTREAL, QUEBEC**

5155 J-ARMAND BOMBARDIER  
SAINT-HUBERT, QUÉBEC  
CANADA J3Z 1G4  
PHONE: 514-933-2711  
FAX: 514-933-8639

**VANCOUVER,**

**BRITISH COLUMBIA**  
1538 KEBET WAY  
PORT COQUITLAM,  
BRITISH COLUMBIA V3C 5M5  
PHONE 604-421-2822  
FAX: 604-421-3113

**WINNIPEG, MANITOBA**

54 PRINCESS STREET  
WINNIPEG, MANITOBA R3B 1K2  
PHONE: 204-942-5205  
FAX: 204-956-4251

**MEXICO**

**LEON, GUANAJUATO**  
KM. 2.0 BLVD. AEROPUERTO  
LEON, GUANAJUATO, CP37545  
MEXICO  
PHONE: +52 477 761 2030  
FAX: +52 477 761 2010

**Baldor Electric Company**

P.O. Box 2400

Fort Smith, AR 72902-2400 U.S.A.

Ph (479) 646-4711 • Fax (479) 648-5792

International Fax (479) 648-5895

[www.baldor.com](http://www.baldor.com)