 <b>PRODUCT DRAWING</b> <small>YORK INTERNATIONAL CORPORATION  P.O. Box 1592, York, PA 17405</small>	Supersedes: Nothing <span style="float: right;">Form 160.49-PW7 (297)</span> <p style="text-align: center;"><b>WIRING DIAGRAM,  MILLENNIUM MODEL YK LIQUID CHILLERS  MICROCOMPUTER CONTROL CENTER  WITH ELECTRO-MECHANICAL STARTER</b></p>	
CONTRACTOR _____ ORDER NO. _____ YORK CONTRACT NO. _____ YORK ORDER NO. _____	PURCHASER _____ JOB NAME _____ LOCATION _____ ENGINEER _____	
<input type="checkbox"/> REFERENCE    DATE _____	<input type="checkbox"/> APPROVAL    DATE _____	<input type="checkbox"/> CONSTRUCTION    DATE _____

For use with York Centrifugal Liquid Chilling Units shown below:

Models YK (Style C)  
\_\_\_\_\_

**JOB DATA:**

CHILLER MODEL NO. YK \_\_\_\_\_

NO. OF UNITS \_\_\_\_\_

COMPRESSOR MOTOR \_\_\_\_\_ VOLTS, 3-PHASE, \_\_\_\_\_ Hz

OIL PUMP MOTOR \_\_\_\_\_ VOLTS, 3-PHASE, \_\_\_\_\_ Hz, \_\_\_\_\_ FLA

**REMARKS:**

---

---

---

---

---

---

---

---







---

---





















# LEGEND

## LEGEND

IHTR	THERMOSTATICALLY CONTROLLED 1500 WATT OIL HEATER (115 VAC)	LWT	LOW WATER TEMPERATURE (PROVIDED BY RT1)
2HTR	THERMOSTATICALLY CONTROLLED 1500 WATT OIL HEATER (OIL PUMP VOLTAGE)	MOV	METAL OXIDE VARISTOR
IM	3 PHASE OIL PUMP STARTER	OL	MOTOR STARTER OVERLOADS
2M	COMPRESSOR MOTOR STARTER	OP	LOW OIL PRESSURE (PROVIDED BY TWO TRANSDUCERS)
3M	CONDENSER PUMP MOTOR STARTER	OVA	ORIFICE VALVE ACTUATOR
IR	COMPRESSOR MOTOR / IHTR HEATER CONTROL RELAY	PRV	PRE-ROTATION VANE MOTOR
2R	2HTR HEATER CONTROL RELAY	RT1-RT9	RESISTANCE TEMPERATURE SENSING ELEMENT
ISOL	OIL RETURN SOLENOID VALVE	RES	RESISTOR
2SOL	LIQUID LINE SOLENOID VALVE		TRANSIENT SUPPRESSOR
3SOL	VENT LINE SOLENOID VALVE	TB1, TB3, TB6,	TERMINAL BLOCK, FACTORY WIRING — 
4SOL	HIGH SPEED THRUST SOLENOID VALVE	TB7	
ISS	DPDT 3 POSITION ROCKER SWITCH	TB2, TB4,	TERMINAL BLOCK, FIELD CONNECTION — 
2SS	4PST 4 POSITION MANUAL OVERRIDE SWITCH	TB5	
IT	CLASS 2 POWER SUPPLY TRANSFORMER	VMP	VANE MOTOR POTENTIOMETER
CM	SOLID STATE OVERLOAD/POWER FAULT CONTACTS (PART OF CM-2 BOARD)	VMS	VANE MOTOR SWITCH
DOC	DIGITAL ORIFICE CONTROLLER	-----	FIELD WIRING
CT	CURRENT TRANSFORMER	=====	FACTORY WIRING
FDT5	FAULTY DISCHARGE TEMP. SENSOR	-----	CIRCUIT BOARD OR ENCLOSURE BOUNDARY
FLA	FULL LOAD AMPS (COMPRESSOR MOTOR)	→	JACK (J1, J2, ...)
FU	FUSE	⌋	PLUG (P1, P2, ...)
HSDT	HIGH SPEED DRAIN TEMP.		WIRE ENTRANCE HOLE IN CONTROL PANEL
PGD	PROXIMITY GAP DISTANCE	-----	OPTION (WHEN SUPPLIED) BY YORK.
HDT	REFRIG. HIGH DISCHARGE TEMP. (PROVIDED BY RT2)	-----	MECHANICAL LINKAGE
HOP	HIGH OIL PRESSURE (PROVIDED BY TWO TRANSDUCERS)		SHIELDED CABLE
HOT	HIGH OIL TEMPERATURE (PROVIDED BY RT3)		METAL OXIDE VARISTOR
HP	HIGH PRESSURE CUTOUT		
LEP	LOW EVAPORATOR PRESSURE (PROVIDED BY EVAP. PRESS TRANSDUCER)		
LLS	LIQUID LEVEL SENSOR (PROBE)		
ILEP	LOW EVAPORATOR PRESSURE CUTOUT (BRINE UNITS ONLY)		
LOT	LOW OIL TEMPERATURE (PROVIDED BY RT3)		
LOTD	LOW OIL TEMP. DIFFERENTIAL (PROVIDED BY RT3 AND CONDENSER PRESS. TRANSDUCER)		

LD00818

### NOTES:

- This wiring diagram describes the standard electronic control scheme for use with an electromechanical starter. For details of standard modifications, refer to Product Form 160.49-PW13.
- Field wiring to be in accordance with the National Electrical Code as well as all other applicable codes and specifications. See Product Drawing Form 160.49-PW10 for field wiring connections.
- Numbers along the left side of diagram are line identification numbers. The numbers along the right side indicate the line number location of relay contacts. An underlined contact location signifies a normally closed contact.
- Main control panel Class 1 field wiring terminal connection points are indicated by numbers within a rectangle, i.e.  15. Main control panel factory wiring terminal connection points are indicated by numbers within a triangle, i.e.  5. Component terminal markings are indicated by numbers within a circle, i.e.  1. Numbers adjacent to circuit lines are the circuit identification numbers.
- To cycle unit on and off automatically with contacts other than those shown, install a cycling device between terminals  1 &  13 (line 27) (see note 9). If a cycling device is installed, jumper must be removed between terminals  1 &  13.
- Compressor motor starter with starter interlock contacts (rated 0.5 to 1.0 amp @ 24 volts A.C.) must be per Form 160.45-PA5.1. Control panel shall be grounded.
- Units installed in Canada must have a field supplied CSA approved 30 amp disconnect switch and a 20 amp dual element fuse mounted external to control panel for 115 volt control supply.
- To stop unit and not permit it to start again, install a stop device between terminals  1 &  8 (Line 23 (see note 9)). A remote start-stop switch may be connected to terminals  1,  7 &  8 (Lines 22 & 23) (see note 9). Remote start-stop switch (Line 22) is operative only in the "Remote" operating mode.
- Device contact rating to be 5 milliamperes at 115 volts A.C.
- \_\_\_\_\_
- Contact rating is 5 amps resistive at 120 volts A.C. or 240 volts A.C.
- Three phase oil pump must be properly phased. L1, L2 & L3 corresponding to phase sequence A, B & C.
- To check motor rotation on initial start-up, install momentary switch between terminals  24 &  25 (Line 35). Depress start switch. After approx. 30 seconds, jog motor with momentary switch. When proper rotation is obtained, replace momentary switch with jumper. Switch must have a minimum contact rating of 2 FLA, 10 LRA at 115 volts A.C.
- Solid state motor overload (CM) is set to trip at 105% FLA. During momentary power interruption (Power Fault), contact opens for 1 second.
- For high and low voltage units, the factory supplied jumper between  1 &  53 must be removed when electromechanical starter overloads and/or safety devices are used. For high voltage (2300-4160) UL and CSA approved units only, electromechanical compressor motor starter overloads (normally closed) must be connected between  1 &  53.
- Contact rating is 5 amps resistive @ 250 volts A.C. & 30 volts D.C., 2 amp inductive (.4 PF) @ 250 volts A.C. & 30 volts D.C.
- Each 115 VAC field-connected inductive load: i.e., relay coil, motor starter coil, etc., shall have a transient suppressor wired in parallel with its coil, physically located at the coil. Spare transient suppressors and control circuit fuses are supplied in a bag attached to the top of the hinged panel.

# ELEMENTARY DIAGRAM (Cont'd.)

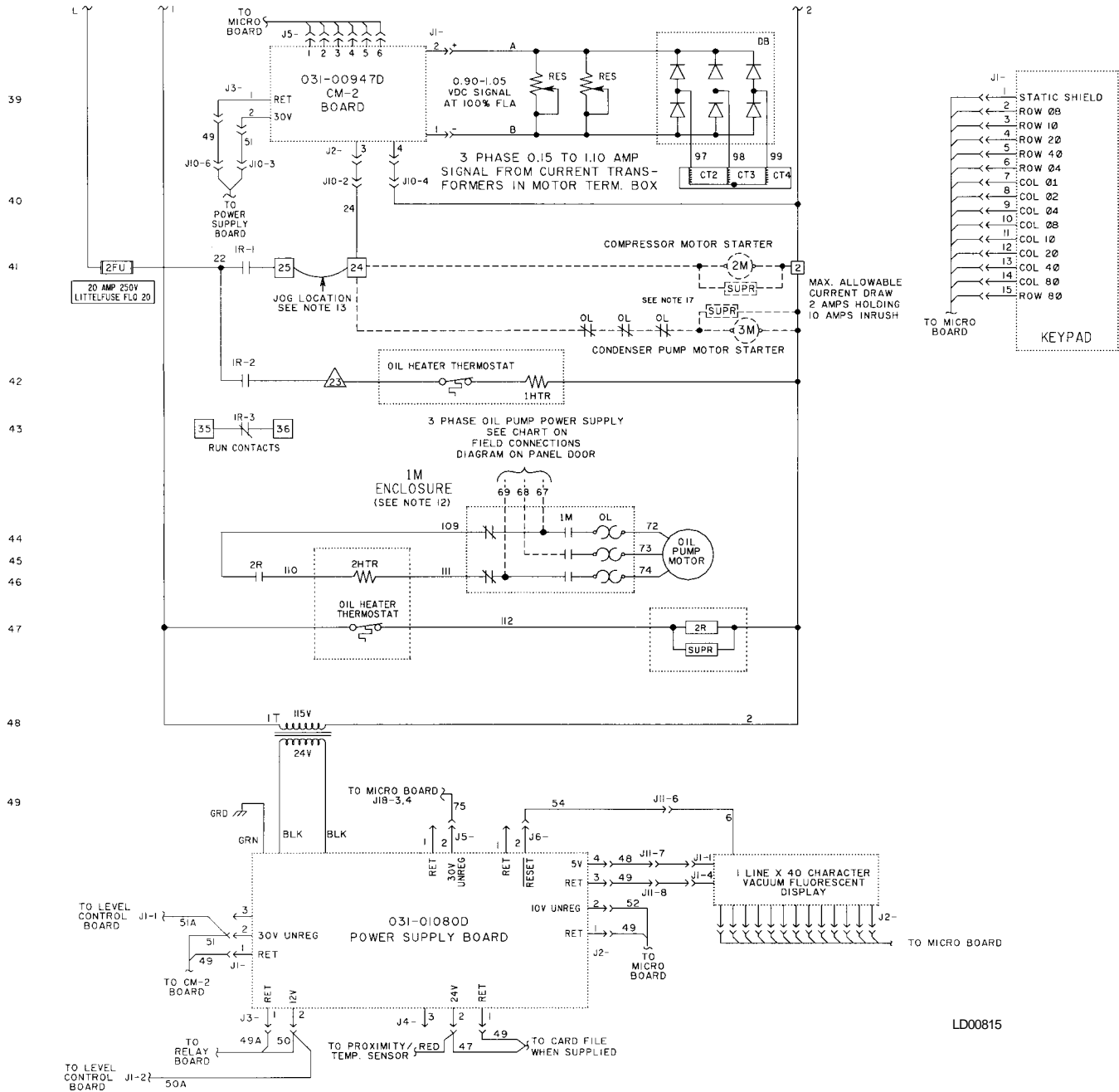

LD00815

# TIMING DIAGRAM

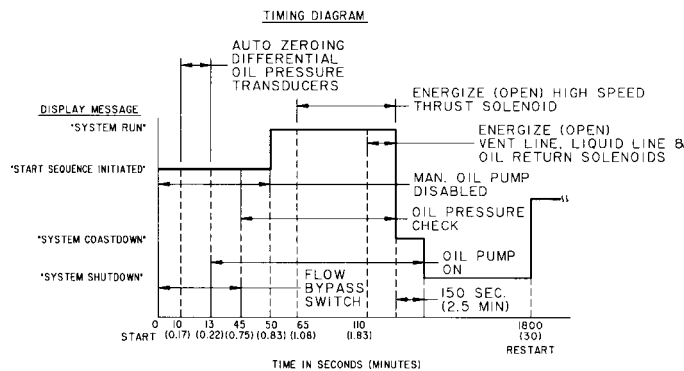

LD00816



PRESSURE-TEMPERATURE CHART							
APPLICATION		DEVICE	UNITS	OPERATING POINT			
CHILLED WATER	BRINE			ON RISE		ON FALL	
✓	✓	HDT	DEG.F/DEG.C	220/104.4		219/103.9	
✓	✓	HOT	DEG.F/DEG.C	180/82.2		179/81.7	
✓	✓	OP	PSID/kPa	25/172		15/104	
✓	✓	HP (R-22)	PSIG/kPa	CUT-OUT 265/1827	INHIBIT PRV OPENING * 246.3/1698	ALLOW PRV OPENING * 245/1689	CUT-IN 205/1413
✓	✓	HP (R-134a)	PSIG/kPa	CUT-OUT 180/1241	INHIBIT PRV OPENING * 162.5/1120	ALLOW PRV OPENING * 160/1103	CUT-IN 120/827
✓		LEP (R-22)	PSIG/kPa	CUT-IN 54.4/375	ALLOW PRV OPENING 57.5/396	INHIBIT PRV OPENING 56.2/387	CUT-OUT 54.3/374
✓		LEP (R-134a)	PSIG/kPa	CUT-IN 25.1/173	ALLOW PRV OPENING 28.0/193	INHIBIT PRV OPENING 27.0/186	CUT-OUT 25.0/172
	✓	ILEP	PSIG				
✓	✓	HOP-FOR FIRST 7 MINUTES OF COMPR. OPERATION	PSID/kPa	125/861.9		124/855.0	
✓	✓	HOP-AFTER THE FIRST 7 MINUTES OF COMPR. OPERATION	PSID/kPa	60/413.7		59/406.8	
✓	✓	FDS	DEG.F/DEG.C	30.0/-1.10		29.9/-1.20	
✓		LWT	DEG.F/DEG.C	CHILLED LIQUID TEMP. SETPOINT	AT OR ABOVE LCWT= 40/4.4, LWT=4/2.2 BELOW THE CHILLED LIQ. TEMP. SETPOINT: WHEN THE SETPOINT IS RAISED, LWT= 36/2.2 FOR 10 MINUTES. BELOW LWCT=40/4.4, LWT=36/2.2		
	✓	LWT	DEG.F/DEG.C	CHILLED LIQUID TEMP. SETPOINT	LWT = 4/2.2 BELOW THE CHILLED LIQ. TEMP. SETPOINT		
✓	✓	LOT	DEG.F/DEG.C	71.0/21.7		55.0/12.8	
✓	✓	LOTD†	DEG.F/DEG.C	30/16.7		29.9/16.6	
✓	✓	LOTD††	DEG.F/DEG.C	40/22.2		39.9/22.1	
✓	✓	HSDT	DEG.F/DEG.C	CUTOUT 250/121.1	CUTIN 180/82.2 & MANUAL RESET		

- \* - FUNCTION PROVIDED BY CONDENSER TRANSDUCER  
† - APPLICABLE IF UNIT WAS SHUTDOWN FOR 30 MINS. OR LESS  
†† - APPLICABLE IF UNIT WAS SHUTDOWN FOR GREATER THAN 30 MINS.

LD00817

# CONNECTION DIAGRAM

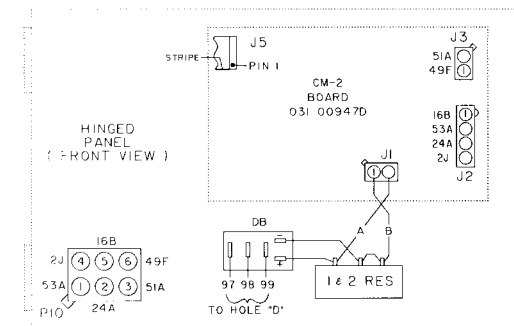
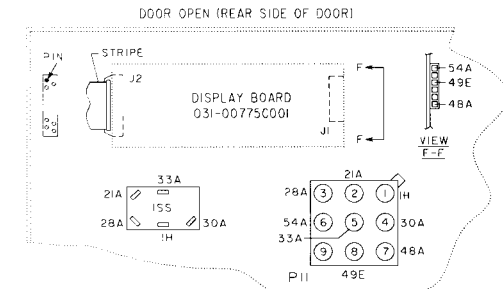

- TO REMOTE L/CWT SET POINT (PWM SIGNAL) I,19 (SEE NOTES 1,9)
- TO REMOTE CURRENT LIMIT SET POINT (PWM SIGNAL) I,20 (SEE NOTES 1,9)
- TO CHILLED WATER PUMP CONTACTS 44,45 (SEE NOTES 16,17)
- TO REMOTE MODE READY TO START CONTACTS 26,27 (SEE NOTES 16,17)
- TO CYCLING SHUTDOWN CONTACTS 40,41 (SEE NOTES 16,17)
- TO RUN CONTACTS 35,36 (SEE NOTES 11,17)
- TO CONDENSER PUMP MOTOR STARTER 2,24
- TO AUXILIARY SAFETY SHUTDOWN CONTACTS I,31 (SEE NOTES 1,9)
- TO CHILLED WATER PUMP INTERLOCK OR FLOW SWITCH I,12 (SEE NOTE 9)
- TO SAFETY SHUTDOWN CONTACTS 42,43 (SEE NOTES 16,17)
- TO CONTACTS THAT CYCLE UNIT I,7,8,13 (SEE NOTES 5,8,9)
- TO COMPRESSOR MOTOR STARTER 1,3,4,13,24,53 WITH CONTROL SUPPLY TRANSFORMER I,2 (GROUNDED CONDUCTOR) 11V, 50/60HZ, 15AMPS (SEE NOTES 6,7)
- TO MULTI-UNIT 1 SEQUENCE CONTACTS I,9 (SEE NOTES 1,9)

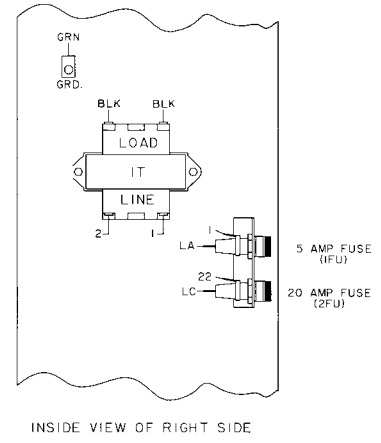
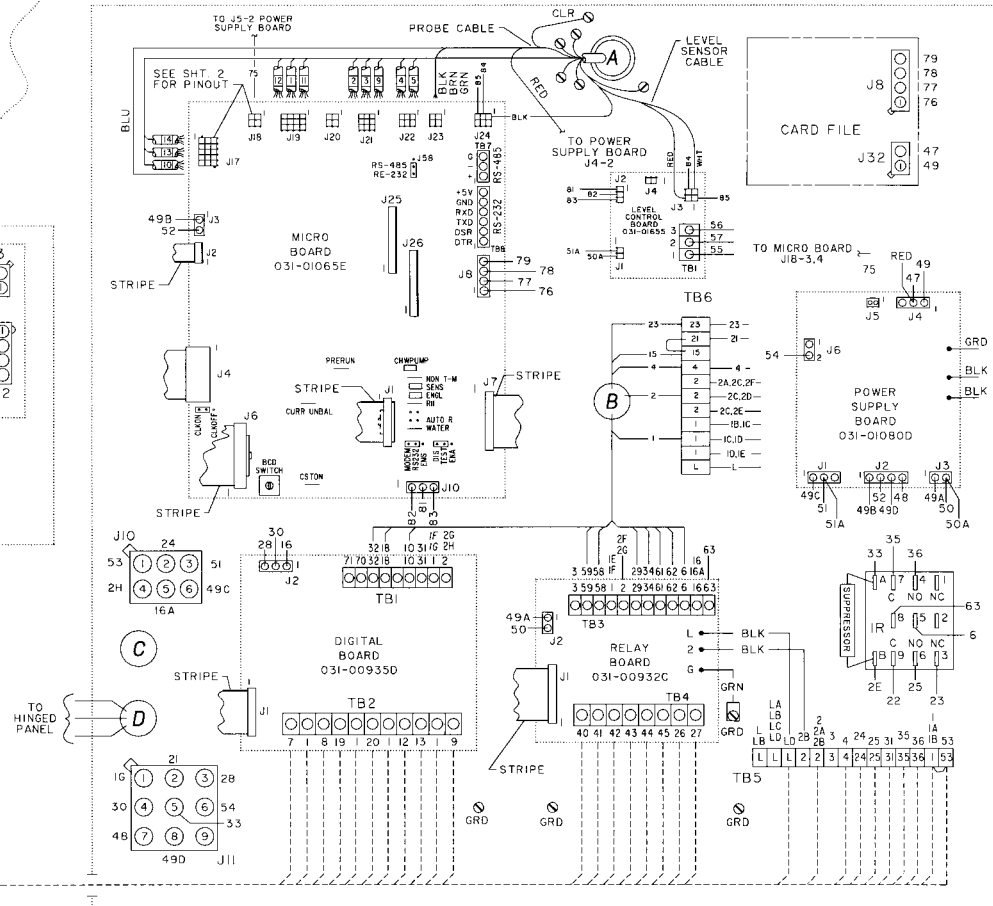

# CONNECTION DIAGRAM (Cont'd.)

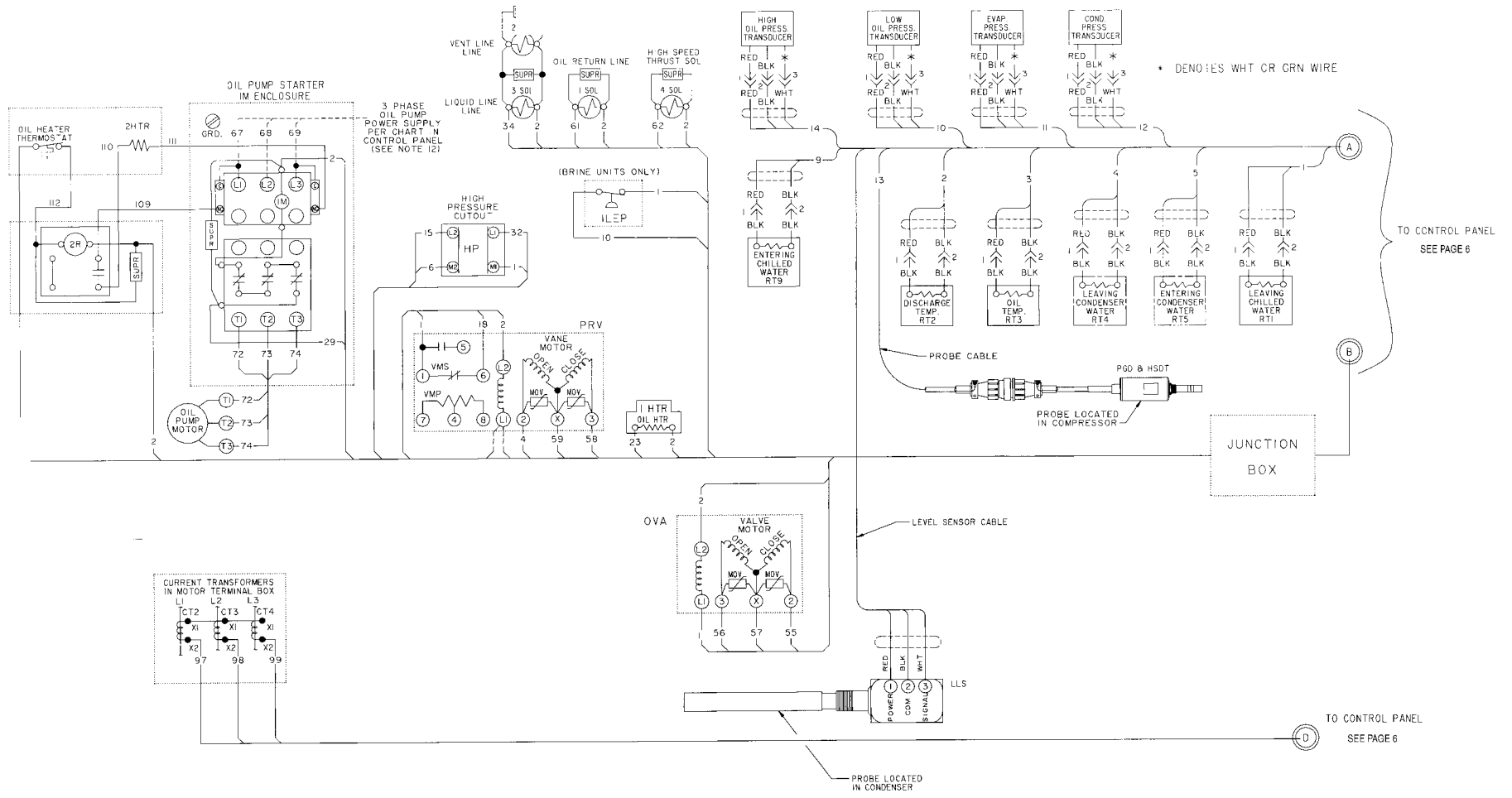

LD00821

OIL PUMP MOTOR		OIL PUMP STARTER OVERLOAD HEATERS				
VOLTS-PH-HZ	FULL LOAD AMPS	MANUFACTURER	MANUFACTURER'S PART NO.	TRIP AMPS	MAXIMUM DUAL ELEMENT FUSE SIZE	% PROTECTION
200-3-60	7.2	FURNAS	K49	9.80	30	136
208-3-60	6.8	↓	K43	8.55	30	126
220-3-60	6.7		K43	8.55	30	128
230-3-60	6.7		K43	8.55	30	128
240-3-60	6.7		K43	8.55	30	128
380-3-60	3.9		K34	5.02	15	129
416-3-60	3.4		K33	4.67	15	137
440-3-60	3.35		K32	4.23	12	126
460-3-60	3.35		K32	4.23	12	126
480-3-60	3.4		K33	4.67	15	137
550-3-60	2.6		K29	3.61	10	139
575-3-60	2.6		K29	3.61	10	139
600-3-60	2.7		K29	3.61	10	134
346-3-50	3.9		K34	5.02	15	129
380-3-50	3.4		K33	4.67	15	137
400-3-50	3.4		K33	4.67	15	137
415-3-50	3.6		K33	4.67	15	130
220-3-50	6.2		K42	8.05	25	130
440-3-50	3.1		K31	3.93	10	127



Proud Sponsor  
of the 1998  
U.S. Olympic Team

36USC380