



**DuPont E315 Powerhouse
CT Replacement**

Wilmington, DE

SUBMITTAL DATA

FOR: (RECORD)

REVISION: (1)

DATE: August 3, 2017

PURCHASER: E.I DuPont de Nemours & Co.
Wilmington, DE

ENGINEER: Pennoni Associates
Newark, DE

Equipment Summary

Four (4) Evapco Model UT-228-926-S Dual Cell Cooling Towers (TAG: CT-99-001-002, CT998-001-002)

Submitted By: Michael J. Haggarty Jr. P.E.

Cell Phone: 302.593.9344

Email: MikeH@etshvac.com

425 McFarlan Road
Suite 209
Kennett Square, PA
19348

Office
610.444.0333
Fax
610.444.0332



Michael J. Haggarty Jr. P.E.
 Energy Transfer Solutions, LLC.
 425 McFarlan Road
 Kennett Square, PA, 19348, USA
 1-610-444-0333 Fax: 1-610-444-0332
 Date: 5/23/17

Project: DuPont E315 CT Replacement

SCOPE OF WORK & QA CLARIFICATIONS

CT-997-001, CT-997-002, CT-998-001, CT-998-002

Four (4) EVAPCO Model UT-228-926-S induced draft counter-flow cooling towers, each unit with CTI Certified performance to cool 8,164 GPM of water from 95°F to 85°F at 78.00°F entering wet bulb temperature.

Technical Data for each unit:

# Fan Motors (HP):	(4)	60.00
Air Flow (CFM):		554,389
Inlet Pressure Drop (psi):		2.8
Evaporated Water Rate (gpm):		65.3
Drift Loss:		0.001%
Operating Weight (lbs):		84,000
Shipping Weight (lbs):		50,340

Standard Features included with offer:

- CTI Certified performance
- IBC Compliant up to 1g & 60 psf.
- Louver Access Door
- Fan Motor: Inverter Duty Premium Efficient
- G-235 Galvanized Steel Casing

Options Included:

- 5-Probe Electronic Water Level Control
- 304 Stainless Steel Cold Water Basin
- Motor Davit with Base – 1 Per Motor
- Vibration Switch – 1 Per Motor
- Baldor Motor Brushes – Mounted on outside of Motor housing Shaft Grounding Rings for Use with VFDs – 1 Per Motor
- Bottom Suction Connections
- Bottom Equalizer Connection (4) 12 inches
- Bottom Inlet Connections
- Side Bypass Connections
- Custom External Service Platform
 - Custom Platform Per Attached Sketch
 - Requires Customer Provided External Support & Customer Supplied Stair Access\
 - Evapco Provided additional details for handrail system to Customer under separate submission.
- Super Low Sound Fan

- Water Silencers
- Heater Option
 - Steam Heater Option – Includes internal steam heater for each unit, Qty (2) total, (1) per cell. Temperature Controls of Steam Heaters are provided & installed by others including Thermostat, Temp Sensor & Bulb well and Low Water Cutoff, the Steam control Valve and steam specialties, traps etc. are also provided by others.
- Sump Sweeper Piping with High Flow Eductors – Factory installed sump sweeper piping including high flow educator nozzles, per Lakos recommended layout.
- Flanged Connections for Cooling Tower (SS Flanges 125lb – Shipped Attached)
 - Qty (10)/Unit Flanged Connections for pipe sizes greater than 4”
 - (2) 14” Inlets, (2) 14” Outlets, (2) 14” Equalizer, (2) 12” Bypass, (2) 6” Sump Sweeper Outlets
 - Qty (10)/Unit Flanged Connection for pipe sizes equal to or smaller than 4”
 - (2) 4” Sump Sweeper Inlets, (2) 4” Drain, (2) 4” Overflow, (2) 3” Steam Inlets, (2) 3” Steam Outlets

Items Discussed and Agreed to by DuPont/Design/Construction/Evapco:

1. Aegis grounding rings are provided. No action required. (I agree) – Changed to Baldor Motor Brushes.
2. Evapco dynamically balances with fan mounted in assembly of the cooling tower. Evapco balances to G6.3. DuPont requesting balance to G2.5 and will investigate if this is doable. Evapco vibration tests to ensure not exceeding 0.22 inches per second. -- Evapco will go one more round on the dynamic balance; however there is no guarantee that will get us to G2.5. No cost impact. (Agreed)
3. Evapco will support the fan shaft at both bearing locations and check runout does not exceed 0.003 TR at mid point. – Evapco will check runout to ensure it does not exceed 0.003 TR. (Agreed)
4. Ball bearings are being provided and are acceptable.
5. DuPont requires that all cut edges of CT casing be deburred to ensure to sharp edges are left on the unit. This is a very important safety issue for DuPont and must be addressed. - Evapco will double check all edges and deburr. (Agree, the edges need to be deburred)
6. Add second motor base adjustment threaded rod and locking nut. -- Evapco believes this is possible(Picture #2 Below); however it has not been built/tested. Prior to shipping Evapco would like to physically build one and verify there are no issues. There will be no additional cost for this item. (Agree)
7. Each CT Cell will be provided with a fitting for a thermowell for basin temperature sensing. The thermowell and temperature sensor will be supplied by A.C.E.

PICTURE #1:
SHAFT ASSEMBLY WITH
BEARINGS & SHEAVES

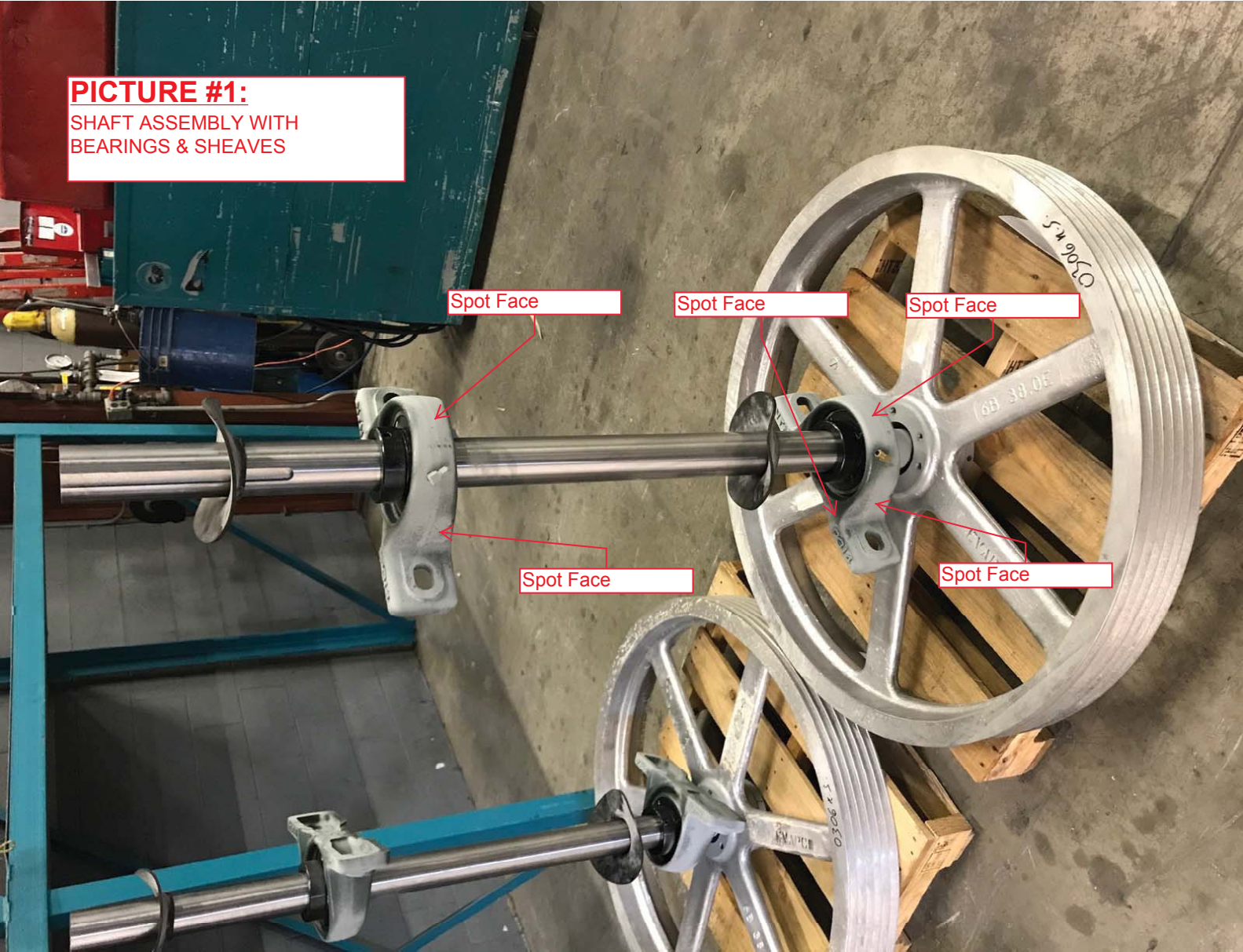

Picture #2:
Motor Support with
Threaded Drive Rod

Additional thread
for adjustment of
motor mount

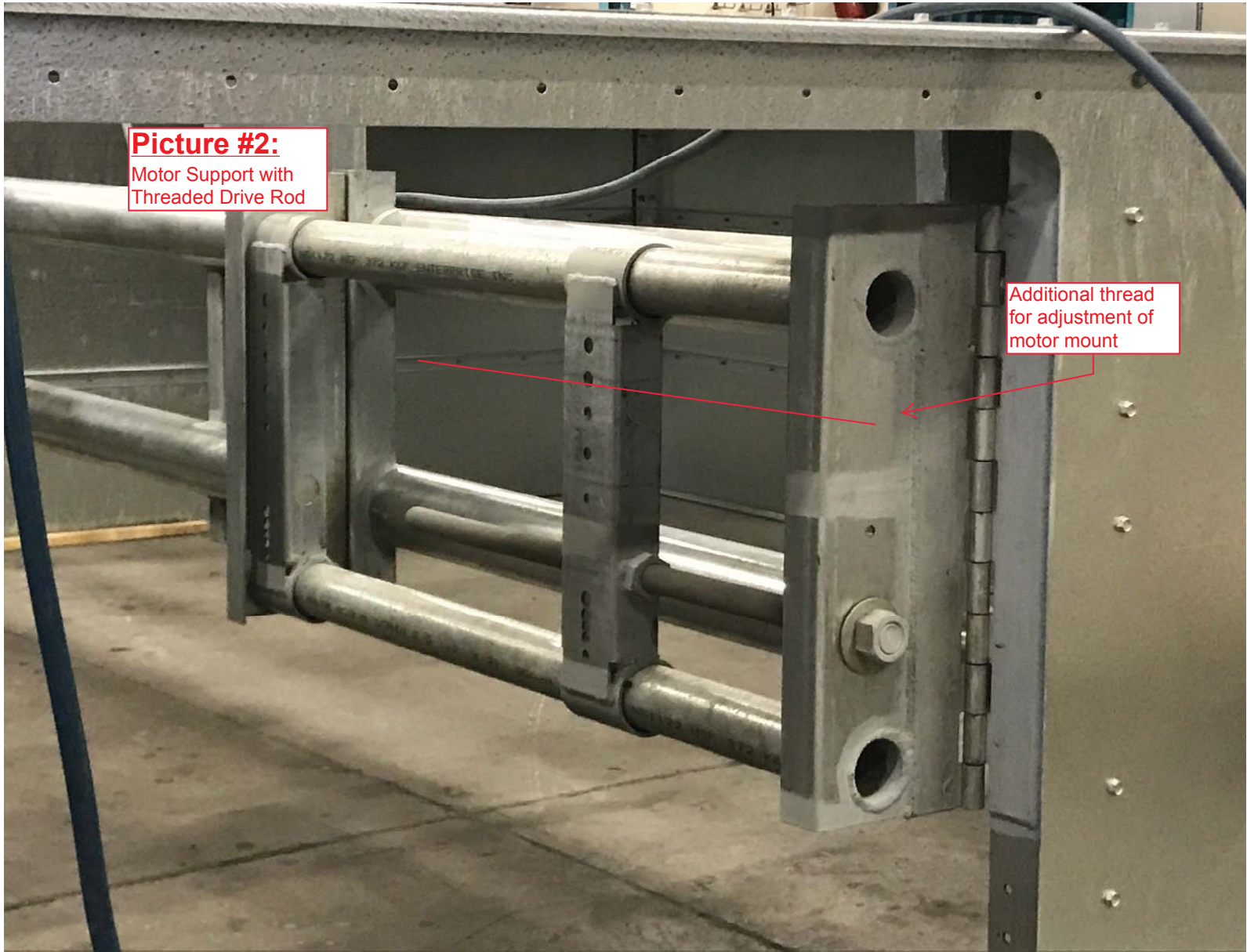



COOLING TOWER EXPRESS WARRANTY – EXTENDED 5 YEAR/5 YEAR

Applies to Evapco Cooling Tower Model No. UT-228-926-S Serial No. 17-812002-05

MANUFACTURER'S EXPRESS WARRANTY

EVAPCO warrants the mechanical equipment components consisting of the fan(s), bearings, pulleys, shafts, belts, gear reducer(s), drive shaft(s), drive couplings, electric fan motor(s) and mechanical equipment supports to be free from defects in materials and workmanship for a period of **five (5) years** from the date of shipment by Evapco. Any component not listed above is warranted against defects in materials and workmanship for a period of **five (5) years** from the date installation is completed in accordance with good manufacturing practices, but not to exceed **sixty six (66) months** from the date of shipment from EVAPCO. This five (5) year product warranty includes all structural components, fill and fill supports, drift eliminators and their supports, air inlet louvers or screens and their supports. All electrical components are warranted against defects in material and workmanship for a period of **one (1) year** from date of installation is completed in accordance with good manufacturing practices, but not to exceed **eighteen (18) months** from the date of shipment from EVAPCO. **Labor costs associated with any repair work performed under the terms of the warranty are NOT included within the warranty.** Damage caused by misuse of the product, including without limitation failure to properly install or maintain the product, is NOT covered by the warranty. This warranty is predicated on unit operation and maintenance in accordance with EVAPCO's recommended operation and maintenance procedures.

In addition to the unit warranty above, EVAPCO warrants the thermal performance of the unit as shown on the certified drawings delivered to the customer for a period of one-year from the date installation is completed in accordance with good engineering practices, but in no event shall such warranty period exceed eighteen (18) months from the date the unit is shipped by EVAPCO. If after installation and start-up there is any question regarding thermal performance of the equipment, at the owner's request EVAPCO will send its engineers to the jobsite to conduct a performance test. This test may be observed by the owner and the consulting engineer or by their authorized representatives. If the results of the evaluation show the equipment to be deficient, EVAPCO will make the necessary repairs or alterations to correct the deficiency subject to the limitations set forth below. If the equipment is found to be performing in accordance with its certified capacity, the owner will reimburse EVAPCO for all direct expenses incurred in connection with such performance test.

LIMITATION OF LIABILITY

THE SOLE REMEDY FOR BREACH OF THE EXPRESS WARRANTIES DESCRIBED HEREIN SHALL BE REPAIR OR REPLACEMENT OF THE EQUIPMENT BY EVAPCO, OR REFUNDING THE PURCHASE PRICE SET FORTH ON THE PURCHASE ORDER. IT SHALL BE IN EVAPCO'S SOLE DISCRETION AS TO WHETHER REPAIR, REPLACEMENT OR REFUND IS THE OFFERED REMEDY. IF EVAPCO DECIDES TO MAKE REPAIRS, EVAPCO HAS THE OPTION OF COMPLETING ALL NECESSARY REPAIRS ITSELF, OR AUTHORIZING A THIRD PARTY TO PERFORM SUCH REPAIRS AT EVAPCO'S EXPENSE. EVAPCO IS NOT RESPONSIBLE FOR ANY REPAIR WORK PERFORMED BY A THIRD PARTY THAT EVAPCO DID NOT PRE-APPROVE IN WRITING. EVAPCO IS ONLY RESPONSIBLE FOR COSTS THAT PERTAIN TO REPAIR OR REPLACEMENT OF EQUIPMENT SUPPLIED BY EVAPCO (i.e., EVAPCO IS NOT RESPONSIBLE FOR REPLACEMENT OR MODIFICATION OF PIPING, SUPPORTING STEEL, ELECTRICAL WIRING, MOTOR STARTERS OR "IN AND OUT" COSTS SUCH AS THIRD PARTY LABOR, CRANE OR OTHER EQUIPMENT FEES).

NOTWITHSTANDING ANYTHING ELSE IN THIS DOCUMENT, EVAPCO'S LIABILITY OF ANY KIND WHATSOEVER SHALL NOT EXCEED THE PURCHASE PRICE SET FORTH ON THE PURCHASE ORDER. UNDER NO CIRCUMSTANCES SHALL EVAPCO BE LIABLE FOR LOST PROFITS, LOST SAVINGS, PERSONAL INJURIES, INCIDENTAL DAMAGES, ECONOMIC LOSS, PROPERTY DAMAGE, OR ANY OTHER CONSEQUENTIAL, INDIRECT, INCIDENTAL, OR PUNITIVE DAMAGES, EVEN IF EVAPCO HAS BEEN ADVISED OF THE POSSIBILITY OF SUCH DAMAGES. In addition, Evapco shall not be responsible for any injuries or damages of any kind whatsoever under any theory of tort to the extent the injuries or damage are caused by misuse of the product by buyer or any third party.

DISCLAIMER OF IMPLIED WARRANTIES

OTHER THAN THE EXPRESS MANUFACTURER'S WARRANTY DESCRIBED HEREIN, THE UNIT IS SOLD "AS IS" AND THERE ARE NO OTHER WARRANTIES. EVAPCO HEREBY DISCLAIMS AND EXCLUDES ALL IMPLIED WARRANTIES OF ANY KIND WHATSOEVER, INCLUDING WITHOUT LIMITATION WARRANTIES OF MERCHANTABILITY, THAT THE UNIT IS FIT FOR A PARTICULAR USE OR PURPOSE, THAT THE UNIT IS FIT FOR A PARTICULAR APPLICATION OR ENVIRONMENT, AND ANY WARRANTIES THAT MIGHT OTHERWISE ARISE OUT OF A COURSE OF DEALING BETWEEN THE PARTIES OR USAGE OF TRADE.



EVAPCO, INC
P.O. Box 1300
Westminster, Maryland 21158, USA

Telephone (410) 756-2600
FAX (410) 756-6450

July 28, 2017

E.I. DuPont de Nemours & Co. Inc.
Experimental Station
200 Powder Mill Road
Wilmington, DE 19803

RE: Purchase Order # 6501730659
EVAPCO Order # 17-812002-812005
(4) UT- 228-926-S Cooling Towers
Project - DuPont E315 Powerhouse CT Replacement

Dear Customer:

Enclosed is the revised certified submittal data for the above referenced order. The revised submittal data is provided to show the following changes:

July 28, 2017

- **Added dimensions to external service platform drawing as requested.**

July 10, 2017

- **Tagged units on certified drawing(s).**
- **Relocated sump sweeper outlet connection(s).**

June 23, 2017

- **Motors provided with Baldor Brushes.**

June 08, 2017

- **Added (2) ¾ in FPT extra connections.**

April 19, 2017

- **Changed sweeper, inlet & outlet connections to flanged.**
- **Added a drawing to submittal for steam coil connection location.**
- **Relocated equalizer connections and added a sludge ring to the bottom.**
- **Changed make-up connection to 2”.**

This order is being manufactured at our Taneytown factory using the highest quality materials and will be assembled in accordance with EVAPCO's strict quality control guidelines. All EVAPCO® products undergo a mechanical test prior to shipment to ensure proper field performance.

The basin sections of this order are in our production schedule for shipment on or before 10/2/2017 and 10/9/2017; however, the remaining sections (casings and fans) are in our production schedule for shipment on or before 1/15/2018, 1/22/2018 & 1/26/2018. If you experience any delays in the project, which would affect your shipment requirements, please contact your local EVAPCO representative, Energy Transfer Solutions, Inc. - Delaware, as soon as possible.

Thank you for selecting EVAPCO as your supplier. We appreciate your business and look forward to working with you in the future.

Sincerely,

EVAPCO, INC

Troy Reineck

Troy Reineck
Product Manager

ENCLOSURE(S)

cc: Energy Transfer Solutions, Inc. - Delaware - Greg Haggarty



July 28, 2017

EVAPCO® SUBMITTAL PACKAGE

PROJECT	<u>DUPONT E315 POWERHOUSE CT</u>	UNIT	<u>(4) UT- 228-926-S COOLING TOWERS</u>
CUSTOMER	<u>E.I. DUPONT DE NEMOURS & CO. INC.</u>	P.O.	<u>6501730659</u>
EVAPCO SERIAL NO.	<u>17-812002-812005</u>	ENGINEER	<u>PENNONI ASSOCIATES</u>

SUBMITTAL DATA ENCLOSED

DESCRIPTION

PERFORMANCE AND MECHANICAL SPECIFICATIONS
UNIT CERTIFIED DRAWING
UNIT CERTIFIED DRAWING
ACCESSORY DRAWING
ACCESSORY DRAWING
ELECTRIC WATERLEVEL CONTROL
ELECTRIC WATERLEVEL CONTROL
SUMP SWEEPER PIPING ARRANGEMENT
EXTERNAL SERVICE PLATFORM
VIBRATION SWITCH (SINGLE SPEED)
CERTIFICATE OF COMPLIANCE
WARRANTY
GUARANTEE OF THERMAL PERFORMANCE

DOCUMENT NUMBER

AT12ST-ST
T3BI282660-DRB-003 [C9]
CUSTOMER PLAN VIEW
SCT32826DA-001 [C4]
MDAIBFTML-DC
D2IX0000-A
ELT3MW2C-001
LSWT32824DA-010 [C9]
PLT32826-09 [C13]
VIAU0000-EE
IBCIDCOC001.pdf
WARRANTY
AOS2636

EVAPCO...TAKING QUALITY AND SERVICE TO A HIGHER LEVEL!



PERFORMANCE AND MECHANICAL SPECIFICATIONS

EVAPCO® COOLING TOWER

PROJECT: <u>DuPont E315 Powerhouse CT Replacement</u>	
CUSTOMER: <u>E.I. DuPont de Nemours & Co. Inc.</u>	
ENGINEER: <u>Pennoni Associates</u>	
UNIT: <u>(4) UT- 228-926-S Cooling Towers</u>	
CUSTOMER P.O.	<u>17413BW</u>
EVAPCO SERIAL NO.	<u>17-812002-812005</u>
CAPACITY:	<u>Each Unit 8164 GPM</u>
INLET TEMP:	<u>95°F</u>
OUTLET TEMP:	<u>85°F</u>
E.W.B.:	<u>78°F</u>
FAN MOTOR:	<u>Each Unit (4) 60 HP</u>
ELEC. SPEC.	<u>460/3/60</u>
INLET PRESSURE:	<u>2.5 PSIG</u>
DRIVES SIZED FOR	<u>0" ESP.</u>

UNIT TYPE	Factory assembled, induced draft, counterflow cooling tower.
CONSTRUCTION	All cold water basin components including vertical supports and air inlet louver frames are constructed of type 304 Stainless Steel. All factory basin seams in the cold water basin are welded for water tight construction. Casing, channels and angle supports are constructed of heavy gauge mill hot-dip galvanized steel. All galvanized steel is coated with a minimum of 2.35 ounces of zinc per square foot of area (G-235 designation). During fabrication, all galvanized steel panel edges are coated with a 95% pure zinc-rich compound.
IBC COMPLIANCE	The unit structure is designed, analyzed, and constructed in accordance with the latest edition of International Building Code (IBC) for: $I_p = 1.00, S_{ds} = .84, P = 119$ psf.
PAN STRAINER*	All type 304 stainless steel construction with large area removable perforated screens.
ACCESS	Hinge mounted door in the upper casing for fan drive and water distribution system access. Removable louver panels on all four sides of the unit for pan and sump access.
FAN SHAFT	Solid shaft of ground and polished steel. Exposed surface coated with rust preventative.
FAN SHAFT BEARINGS	Heavy-duty, self-aligning ball type bearings with extended lubrication lines to grease fittings located on access door frame. Bearings are designed for a minimum L-10 life of 75,000 hours.
FAN MOTOR	Totally enclosed, ball bearing type electric motor(s) suitable for moist air service. Motor(s) are Premium Efficient, Class F insulated, 1.15 service factor design. Inverter rated per NEMA MG1 Part 31.4.4.2 and suitable for variable torque applications and constant torque speed range with properly sized and adjusted variable frequency drives.

FAN DRIVE	The fan drive is a multi-groove, solid back, reinforced neoprene V-belt type with taper lock sheaves designed for 150% of the motor nameplate horsepower. Fan and motor sheaves are constructed of aluminum alloy.
FILL	Polyvinyl Chloride (PVC) of cross-fluted design. PVC sheets are bonded together for strength and durability. Fill is self-extinguishing for fire resistance, has a flame spread of 5 under A.S.T.M. designation E-84-81a, and is resistant to rot, decay and biological attack.
WATER DISTRIBUTION SYSTEM	Precision molded ABS, large orifice spray nozzles utilizing fluidic technology for superior water distribution over the fill media and to minimize water distribution system maintenance. Spray header and branches are Schedule 40 Polyvinyl Chloride (PVC) for corrosion resistance with steel connection to attach external piping. Branches have threaded end caps to facilitate debris removal.
ELIMINATORS	The eliminators are constructed entirely of Polyvinyl Chloride (PVC) in easily handled sections. Design incorporates three changes in air direction and limits the water carryover to a maximum of 0.001% of the circulating water rate.
AIR INLET LOUVERS	The air inlet louvers are constructed from UV inhibited polyvinyl chloride (PVC) and incorporate a framed interlocking design that allows for easy removal of louvers for access to the entire basin area for maintenance. The louvers have a minimum of two changes in air direction and are of a non-planar design to prevent splash-out, block direct sunlight and debris from entering the basin. (Patent Pending)
SUPER LOW SOUND AXIAL PROPELLER FAN(S)	Unit is provided with SUPER Low Sound Fan(s). Fans are high efficiency axial propeller type with non-corrosive FRP hub and blade construction. The one-piece molded heavy duty fan construction utilizes a forward swept blade design for superior sound quality. Each fan is statically balanced and installed in a closely fitted cowl with venturi air inlet for maximum fan efficiency. The fan cowl is covered with a heavy gauge hot dip galvanized steel fan guard.
PASSIVATION	All evaporative cooling equipment utilizing galvanized construction requires initial passivation to maximize the service life of the equipment. The sites water treatment vendor should be contacted several weeks prior to adding any water to the system to provide a passivation plan along with associated passivation plan costs.
ELECTRONIC WATER LEVEL CONTROL PACKAGE	Electronic water level control package with five (5) stainless steel water level sensors ((1) one high level, one (1) high level alarm, one (1) low level, one (1) low level alarm and one (1) ground) with a NEMA 4X enclosure mounted in a cleanable Schedule 40 PVC external standpipe with slow closing solenoid valve(s) and "y" strainer(s).
WATER SILENCERS	Internal PVC pan water silencers mounted in basin.
*OMITTED ON UNITS FOR REMOTE SUMP OPERATION	

SPECIAL REMARKS:

- **5-Probe Electronic Water Level Control Package.**
- **Bottom Suction Connection(s).**
- **(2) 14 in Flanged equalizer connection(s).**
- **Unit(s) provided with External Service Platform(s) with Vertical Ladder(s).**
- **Flanged inlet connection (ship mounted).**
- **Flanged outlet connection (ship mounted).**
- **Motor davit and base.**
- **Unit provided with 304 stainless steel steam coil. Pressure and temperature controls by others.**
- **SUPER Low Sound Axial Propeller Fan(s).**
- **Unit provided with vibration cutout switch(es), mounted (wiring and sensitivity adjustment by others).**
- **Water silencers.**
- **Unit provided with Schedule 80 PVC sump sweeper piping consisting of one (1) inlet and one (1) outlet connection per pan section with high flow eductors.**
- **(2) 12 in Flanged bypass connection(s).**
- **Bottom Inlet.**
- **IBC Compliant up to 1g.**
- **Louver access door.**
- **Delete flume box.**
- **Fan Motor(s) to be supplied with shaft grounding rings.**
- **(2) 3/4 in FPT extra connections.**
- **Motors provided with Baldor Brushes.**



Evapco, Inc. Sound Data



Sound Pressure Levels (SPL) in dB RE 0.0002 Microbar
Sound Power Levels (PWL) in dB RE 10⁻¹² Watt

MODEL: UT 228-926-S
MOTOR: 60 Hp (45 kW)
MOTORS: 4
SPEED: Full Speed

Sound Reduction Options
Super Low Sound Fan
Water Silencer

MULTI-CELL DATA

BAND	SOUND PRESSURE LEVEL										SOUND POWER LEVEL
	End		Mtr. Side		End		Opp. Mtr. Side		Top		
	5 ft (1.5 m)	50 ft (15 m)	5 ft (1.5 m)	50 ft (15 m)	5 ft (1.5 m)	50 ft (15 m)	5 ft (1.5 m)	50 ft (15 m)	5 ft (1.5 m)	50 ft (15 m)	
63 HZ	79	74	79	74	79	74	79	74	82	66	105
125 HZ	76	69	76	69	76	69	76	69	82	70	101
250 HZ	70	60	70	59	70	60	70	59	75	67	94
500 HZ	68	57	68	56	68	57	68	56	72	61	90
1 KHZ	68	54	67	54	68	54	67	54	70	58	87
2 KHZ	65	51	65	51	65	51	65	51	67	56	84
4 KHZ	64	48	63	46	64	48	63	46	65	53	81
8 KHZ	65	48	65	46	65	48	65	46	65	54	81
dBA	74	60	73	60	74	60	73	60	76	65	94

- REMARKS: 1. Sound Pressure Levels are according to CTI Standard ATC-128.
2. Sound Power Levels are calculated according to the Small Units Section 8.
3. Sound from free-field conditions over a reflecting plane with +/- 2 db(A) tolerance.
4. Noise levels can increase with variable frequency drives depending on the drive manufacturer and the drive configuration.
5. Complete unit sound data with all fans operating and listed sound reduction option(s).

UNIT		SCALE N.T.S.
MODEL # AT-228-926-S		

EVAPCO, INC.



DWG #	T3BI282660-DRB-003	REV.	2
SERIAL #	17-812002-812005	DATE	07/10/2017

- NOTES:
- (M)- FAN MOTOR LOCATION
 - HEAVIEST SECTION IS FAN SECTION
 - MPT DENOTES MALE PIPE THREAD
FPT DENOTES FEMALE PIPE THREAD
BFW DENOTES BEVELLED FOR WELDING
FLG DENOTES 150# RF FLANGE
 - +UNIT WEIGHT DOES NOT INCLUDE ACCESSORIES (SEE ACCESSORY DRAWINGS)
 - MAKE-UP WATER PRESSURE
20 psi MIN [137 kPa], 50 psi MAX [344 kPa]

- CT-997-001
- CT-997-002
- CT-998-001
- CT-998-002

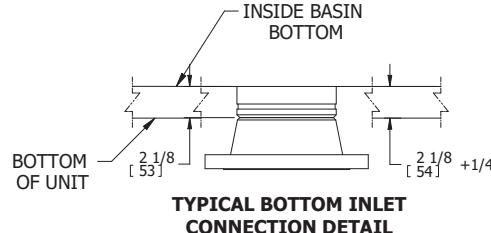

FACE 2 PLAN VIEW

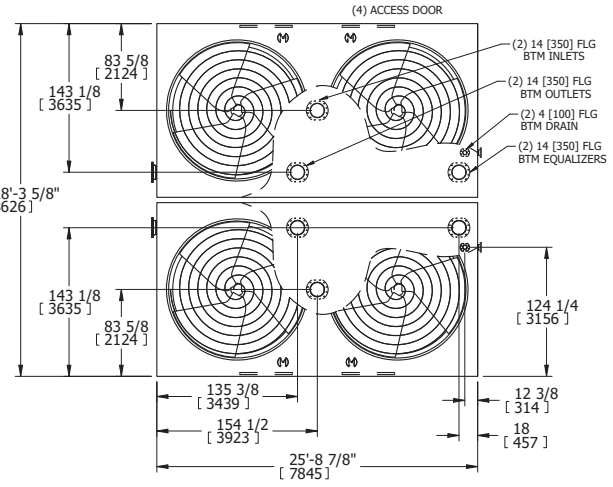

FACE 1

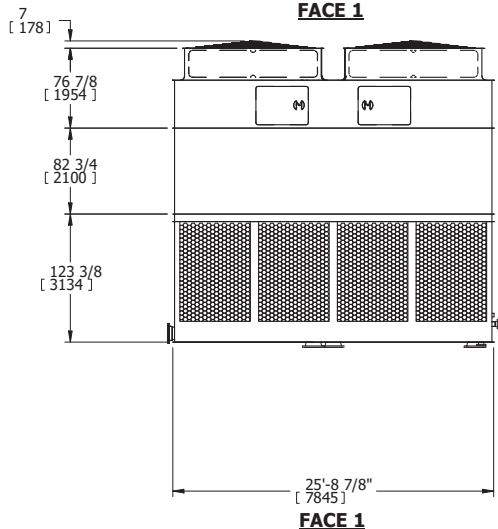

FACE 2

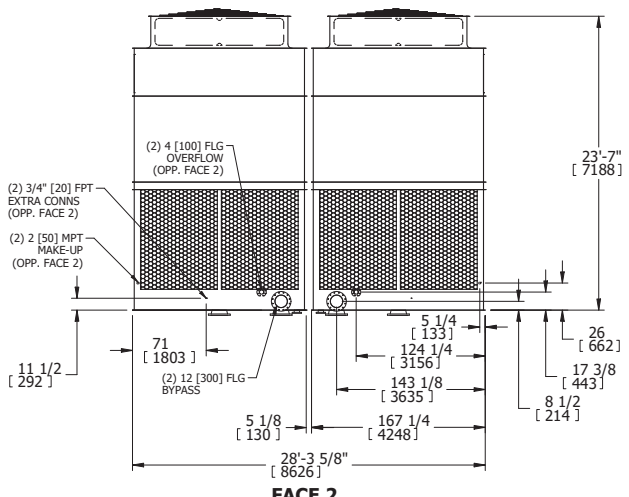

SHIPPING WEIGHT	57960 Lb+ [26290] Kg+	OPERATING WEIGHT	88400 Lb+ [40098] Kg+	HEAVIEST SECTION WEIGHT	11120 Lb+ [5044] Kg+	NO. OF SHIPPING SECTIONS	6	DRAWN BY	JTG
-----------------	-----------------------	------------------	-----------------------	-------------------------	----------------------	--------------------------	---	----------	-----

EVAPCO, INC.

TITLE **HIGH FLOW EDUCTOR ARR**

UNIT: 28X24,26 INDUCED DRAFT UNITS

DWG. # LSWT32824DA-010

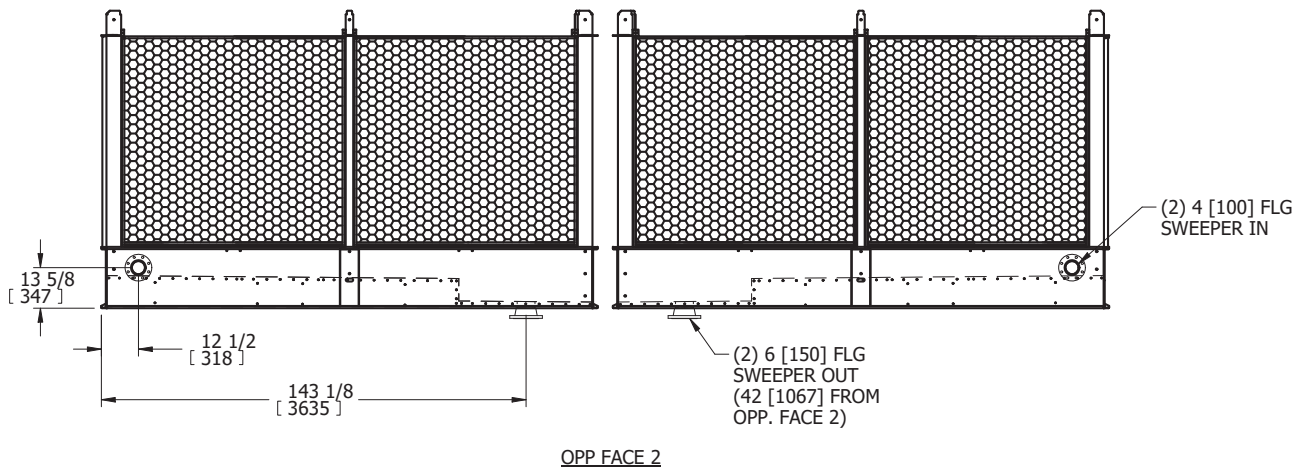

NOTES:

1. FLG DENOTES 150# RF FLANGE
2. UNIT CONNS ARE NOT SHOWN FOR CLARITY.
3. DIMENSIONS LISTED ARE IN ENGLISH AND [METRIC].

EVAPCO, INC.

TITLE HOT WATER/STEAM COIL ARR.	UNIT: 28X26 INDUCED DRAFT TOWER	DWG. # SCT32826DA-001
--	--	------------------------------

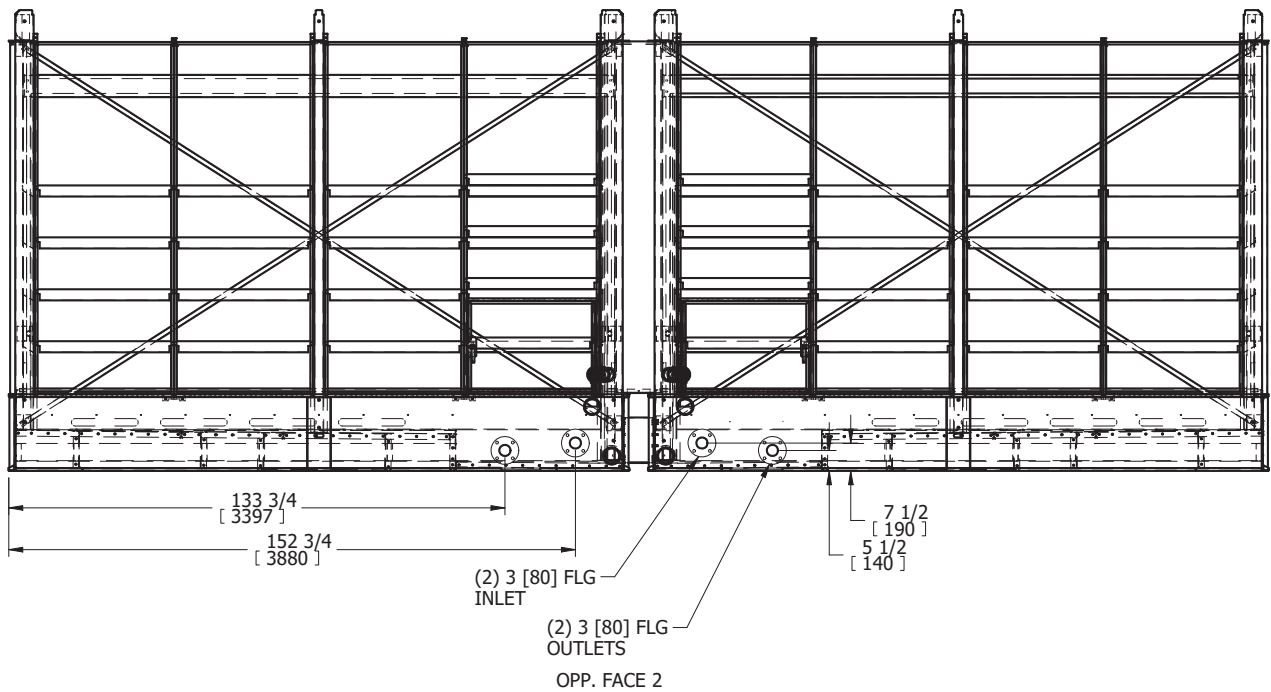

- NOTES:**
1. FLG DENOTES 150# RF FLANGE
 2. HOT WATER/STEAM COIL CIRCUIT IS MADE WITH SCH 40 STEEL PIPE.
 3. HOT WATER OR STEAM IS PROVIDED BY OTHERS.
 4. THE HOT WATER/STEAM COIL IS SIZED TO MAINTAIN 40F PAN WATER TEMPERATURE AT 0F AMBIENT. TEMP/PRESSURE CONTROLS SUPPLIED BY OTHERS.

CONFIDENTIAL
 This document is the property of Evapco, Inc. It should not be copied or disclosed without prior written authorization.

PART NO.	REV. NO.
068-20122F	-

HOT WATER/STEAM
 COIL LOOP

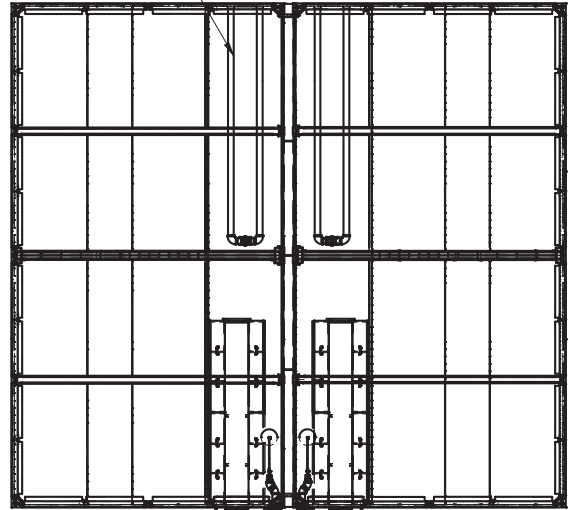

STAINLESS STEEL OPTION	
PART NO.	RAW MATL
NOTE: 1. ALL 1/4Ø HOLES SHOULD BE 11/32Ø 2. USE STAINLESS STEEL N.C. SET-UP SHEET	

REVISIONS

EVAPCO, INC.			
TITLE		AT3 28X26	
GA	RAW MATL	CUT SIZE	
DATE	SCALE	N.C. INFO.	
1/26/17	N.T.S.		
DRAWN BY	CHKD BY	PART NO.	REV. NO.
RW		068-20122F	-
NEXT ASSEMBLY:			

EVAPCO, INC.



TITLE	STEEL SUPPORT CONFIGURATION	UNIT:	28x26 INDUCED DRAFT UNITS	DWG. #	SLIX2826-DB
-------	-----------------------------	-------	---------------------------	--------	-------------

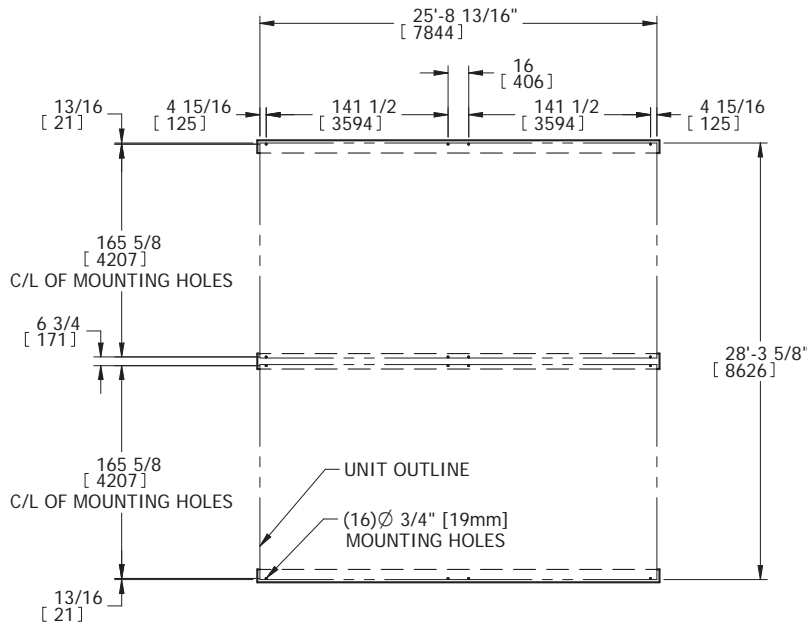

PLAN VIEW

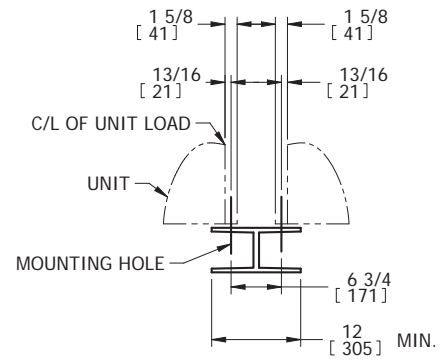

CENTER ARRANGEMENT

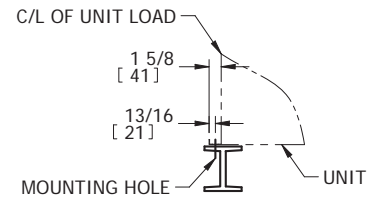

TYPICAL END VIEW

NOTES:

1. BEAMS SHOULD BE SIZED IN ACCORDANCE WITH ACCEPTED STRUCTURAL PRACTICES. MAXIMUM DEFLECTION OF BEAM UNDER UNIT TO BE 1/360 OF UNIT LENGTH NOT TO EXCEED 1/2" [13mm].
2. DEFLECTION MAY BE CALCULATED BY USING 55% OF THE OPERATING WEIGHT AS A UNIFORM LOAD ON EACH BEAM. SEE CERTIFIED PRINT FOR OPERATING WEIGHT.
3. SUPPORT BEAMS AND ANCHOR HARDWARE ARE TO BE FURNISHED BY OTHERS. ANCHOR HARDWARE TO BE ASTM-A325 5/8" [16mm] BOLT OR EQUIVALENT.
4. BEAMS MUST BE LOCATED UNDER THE FULL LENGTH OF THE PAN SECTION.
5. SUPPORTING BEAM SURFACE MUST BE LEVEL. DO NOT LEVEL THE UNIT BY PLACING SHIMS BETWEEN THE UNIT MOUNTING FLANGE AND THE SUPPORTING BEAM.
6. ANCHORING ARRANGEMENT SHOWN HAS A MAXIMUM WIND RATING OF 60 PSF [2.87 KPa] ON CASED VERTICAL SURFACES.
7. THE FACTORY RECOMMENDED STEEL SUPPORT CONFIGURATION IS SHOWN. CONSULT THE FACTORY FOR ALTERNATE SUPPORT CONFIGURATIONS.
8. UNIT SHOULD BE POSITIONED ON STEEL SUCH THAT THE ANCHORING HARDWARE FULLY PENETRATES THE BEAM'S FLANGE AND CLEARS THE BEAM'S WEB.
9. ALL 28 X 24 MODELS ARE MULTIPLE CELL UNITS. OPERATING WEIGHT OF EACH CELL IS FOUND BY DIVIDING TOTAL OPERATING WEIGHT BY THE NUMBER OF CELLS.
10. WHEN VIBRATION ISOLATION IS REQUIRED FOR MULTIPLE CELL UNITS, THE VIBRATION ISOLATORS (BY OTHERS) MUST BE LOCATED UNDER THE SUPPORTING STEEL BEAMS AND NOT BETWEEN THE SUPPORTING STEEL BEAMS AND THE UNIT.
11. THE CENTER BEAM SHOULD HAVE A MINIMUM WIDTH OF 12" [305mm].

EVAPCO, INC.

TITLE **PLAN VIEW** UNIT: ALL 28 X 26 AT COOLING TOWER UNITS DWG. # 17-812002-812005

COOLING TOWER PLATFORMS
ARE BACK TO BACK

OPEN END FOR
FIELD TIE IN BY OTHERS

ACCESS POINT

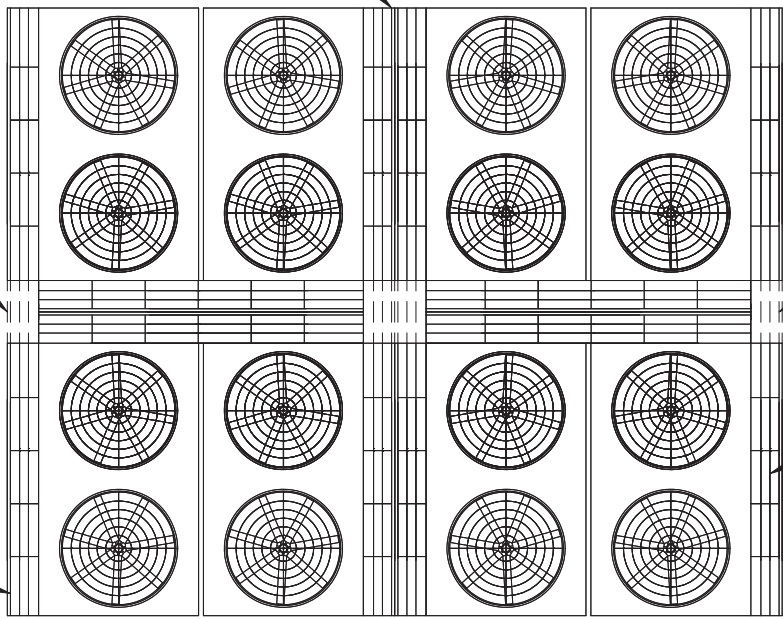

EXTERNAL SUPPORT
BY OTHERS

FACE 1

EVAPCO SUPPLIED
PLATFORM AREA

STAIRWAY SUPPLIED AND
SUPPORTED BY OTHERS

FACE 2

NOTE: NO HANDRAILING FACTORY SUPPLIED
CUSTOMER WILL DESIGN THEIR OWN

EVAPCO, INC.

TITLE **EXTERNAL SERVICE PLATFORM**

UNIT: ALL 28 X 26 AT COOLING TOWER UNITS

DWG. # PLT32826-09

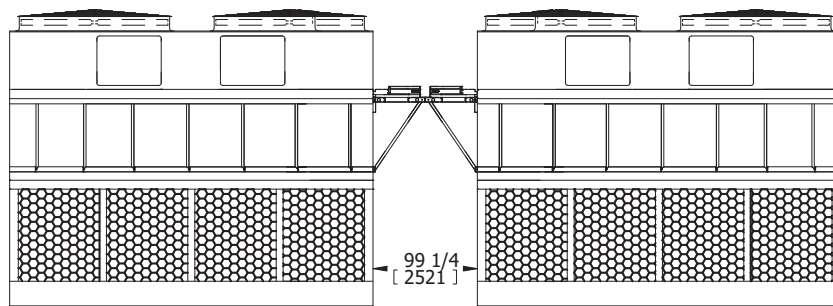

- NOTES:**
1. ALL PLATFORMS WILL SHIP LOOSE. FIELD INSTALLATION BY OTHERS IS REQUIRED.
 2. HANDRAILING NOT SUPPLIED BY FACTORY
 3. REFER TO RIGGING PACK FOR PLATFORM MOUNTING INSTRUCTIONS.
 4. THE PLATFORM ASSY. WEIGHS 28750 LBS [13068KG]
 5. ANY POSSIBLE PIPEWORK AND/OR OBSTRUCTIONS CONFLICTING WITH THE EXTERNAL SERVICE PLATFORM WILL BE THE CUSTOMER'S RESPONSIBILITY FOR RELOCATION.
 6. PLATFORM SPANS BETWEEN CELLS WILL MEET IN THE CENTER. PLATFORMS WILL BE SUPPORTED BY COOLING TOWERS. OPEN AREAS WILL NEED EXTERNAL SUPPORT OTHERS.

FACE 1

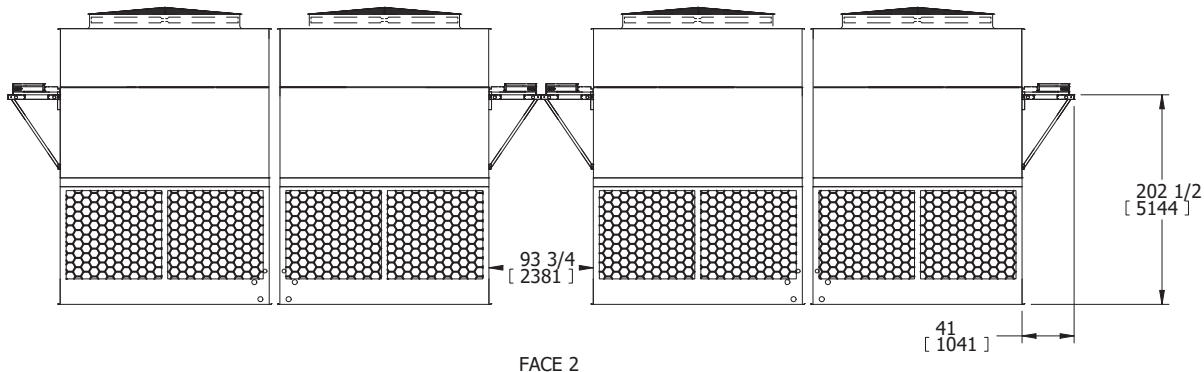

FACE 2

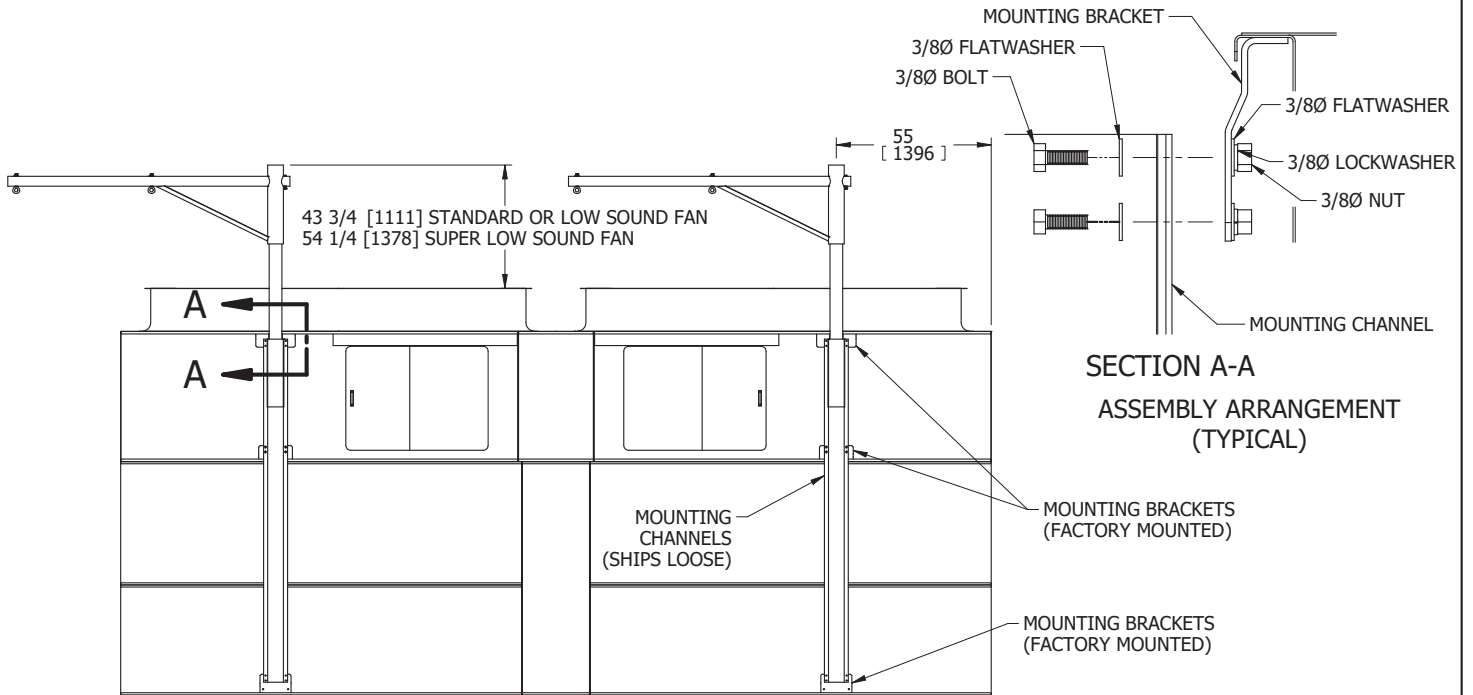

**BELT DRIVE
FOR UNITS WITH AND WITHOUT PLATFORMS**

NOTES:

- A. (M) = MOTOR
- B. DAVIT IS DESIGNED FOR RAISING OR LOWERING EVAPCO FAN MOTORS OR FANS AND GEARS AS UNIT IS EQUIPPED. DO NOT USE FOR ANY OTHER PURPOSE.
- C. DAVIT IS DESIGNED TO PIVOT FREELY AND CAN BE REMOVED FROM ITS MOUNTING BASE FOR STORAGE.
- D. DIMENSIONS LISTED AS FOLLOWS: ENGLISH [METRIC]
IN [mm]



REMOVABLE DAVIT

MDAIBFTML-DC

EVAPCO, INC.

TITLE ELECTRIC WATER LEVEL CONTROL WIRING	DESCRIPTION: INDUCED DRAFT TOWER - 5 PROBE, 2 VALVES	DWG. # D2IX0000-A
--	---	----------------------

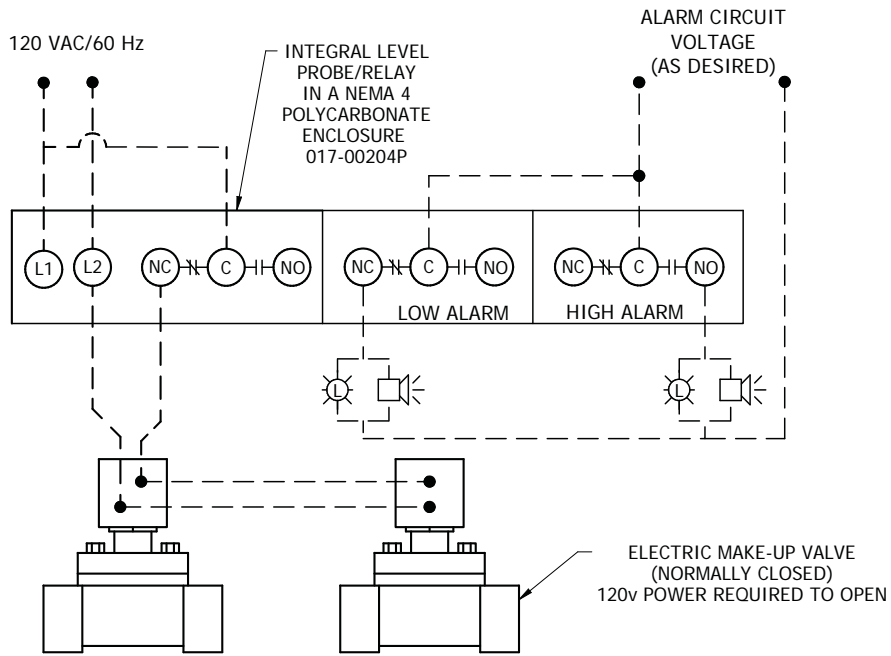

- NOTES:
1. DASHED LINES INDICATE WIRING BY OTHERS.
 2. TYPICAL WIRING PER PROBE.

UNIT	COOLING TOWER	EVAPCO, INC. 	DWG. #	ELT3MW2C-001	
TITLE	ELECTRIC WATER LEVEL CONTROL LOCATION		SCALE	N.T.S.	DRAWN BY

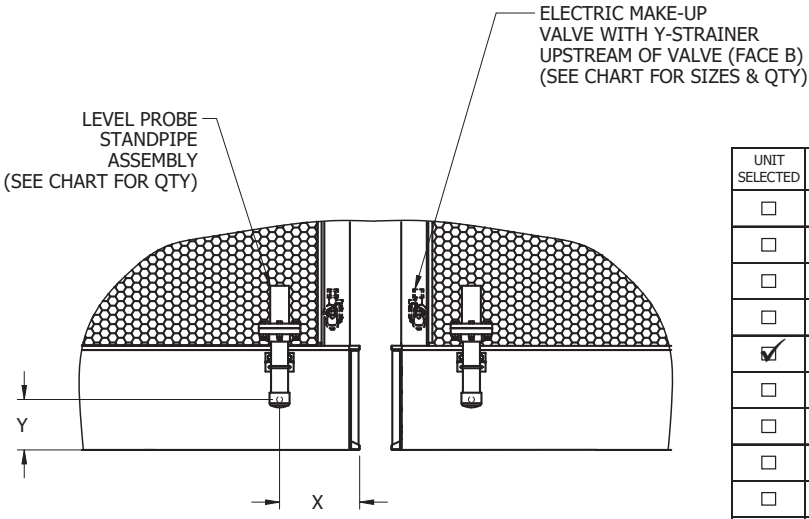

**OPP. FACE 2
IND CELL OPER**

UNIT SELECTED	BOX SIZE	VALVE			Y-STRAINER			STANDPIPE		
		QTY	SIZE	PART NO.	QTY	SIZE	PART NO.	QTY	X	Y
<input type="checkbox"/>	17x9 - 12	2	1" [25]	017-00153P	2	1" [25]	017-00280P	2	1'-8" [508]	8 1/2" [216]
<input type="checkbox"/>	17x14	2	1 1/2" [40]	017-00154P	2	1 1/2" [40]	017-00281P	2	1'-8" [508]	8 1/2" [216]
<input type="checkbox"/>	24x18 - 20	2	2" [50]	017-00155P	2	2" [50]	017-00282P	2	1'-8" [508]	8 1/2" [216]
<input type="checkbox"/>	28x24	2	2" [50]	017-00155P	2	2" [50]	017-00282P	2	1'-8" [508]	8 1/2" [216]
<input checked="" type="checkbox"/>	28x26	2	2" [50]	017-00155P	2	2" [50]	017-00282P	2	2'-0" [610]	8 1/2" [216]
<input type="checkbox"/>	4.8MX10.5	2	1" [25]	017-00153P	2	1" [25]	017-00280P	2	1'-8" [508]	8 1/2" [216]
<input type="checkbox"/>	4.8MX14	2	1 1/2" [40]	017-00154P	2	1 1/2" [40]	017-00281P	2	1'-8" [508]	8 1/2" [216]
<input type="checkbox"/>	6MX12	2	1 1/2" [40]	017-00154P	2	1 1/2" [40]	017-00281P	2	1'-8" [508]	8 1/2" [216]
<input type="checkbox"/>	6MX18	2	2" [50]	017-00155P	2	2" [50]	017-00282P	2	1'-8" [508]	8 1/2" [216]
<input type="checkbox"/>	12x8.5	2	1" [25]	017-00153P	2	1" [25]	017-00280P	2	1'-8" [508]	8 1/2" [216]
<input type="checkbox"/>	15x8.5	2	1" [25]	017-00153P	2	1" [25]	017-00280P	2	1'-8" [508]	8 1/2" [216]

- NOTES:
1. PIPING BY OTHERS.
 2. LEVEL PROBE STANDPIPE ASSEMBLY, MAKE-UP VALVE AND Y-STRAINER TO SHIP LOOSE FOR FIELD MOUNTING BY OTHERS.
 3. SEE CERTIFIED PRINT FOR MAKE-UP LOCATION.
 4. STANDPIPE TO BE HEAT TRACED AND INSULATED FOR WINTER OPERATION (BY OTHERS).
 5. THE ELECTRONIC WATER LEVEL CONTROL ON THIS UNIT WILL MAINTAIN THE PROPER OPERATING WATER LEVEL. HOWEVER, BEFORE INITIAL START-UP THE UNIT MUST BE MANUALLY FILLED TO WITHIN 1" OF THE OVERFLOW.
 6. FOR EASE OF MAINTENANCE, A SHUT-OFF VALVE IS RECOMMENDED UPSTREAM OF Y-STRAINER.
 7. DIMENSIONS LISTED AS FOLLOWS: ENGLISH FT-IN [METRIC] [mm]

EVAPCO, INC.



TITLE	DESCRIPTION:	DWG. #
VIBRATION SWITCH	SINGLE SPEED	V1AU0000-EE

SUPPLIED VOLTAGE, 3 PHASE
INCOMING POWER



SWITCH CONTACT RATING:
15 AMPS, 125, OR 480 Vac; 1/8 HP, 125 Vac; 1/4 HP, 250 Vac; 1/2 AMP, 125 Vdc; 1/4 AMP, 250 Vdc.

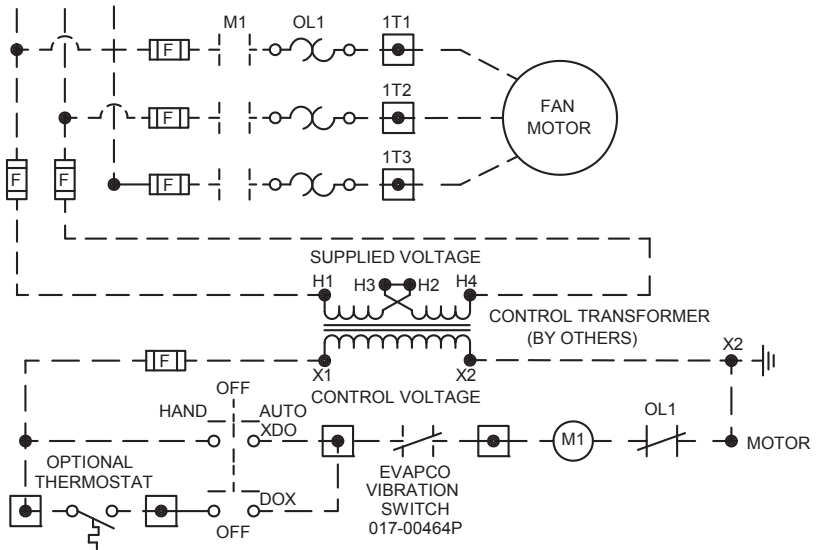

WIRING DIAGRAM:

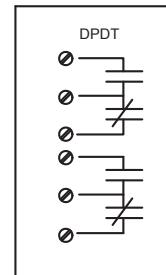

NOTES:

1. DASHED LINES INDICATE WIRING(BY OTHERS)

ADJUSTMENT

ADJUST THE SWITCH SO THAT DURING FULL SPEED START-UP AND UNDER NORMAL CONDITIONS, THE CONTACTS DO NOT TRIP. FIRST, WITH THE MOTOR OFF, TURN THE ADJUSTMENT SCREW COUNTER-CLOCKWISE (MORE SENSITIVE DIRECTION) UNTIL THE SWITCH TRIPS. NEXT, TURN THE ADJUSTMENT SCREW CLOCKWISE 1/8 TURN (LESS SENSITIVE DIRECTION). RESET THE SWITCH BY DEPRESSING THE PUSH-BUTTON RESET LOCATED ON TOP OF THE SWITCH. START THE MOTOR ON FULL SPEED. IF THE MOTOR TRIPS THE SWITCH, THEN TURN THE ADJUSTMENT SCREW CLOCKWISE AN ADDITIONAL 1/8 TURN. RESET THE SWITCH AND START THE MOTOR AGAIN. REPEAT THE ABOVE PROCEDURE UNTIL THE MOTOR CONTINUES TO RUN.



BALDOR® • RELIANCE 

Product Information Packet

EVAPCO

B678921

60HP,1780RPM,3PH,60HZ,364T,A36062M,TEAO

Part Detail							
Revision:	M	Status:	PRD/A	Change #:		Proprietary:	No
Type:	AC	Prod. Type:	A36062M	Elec. Spec:	A36WG0762	CD Diagram:	416820-002
Enclosure:	TEAO	Mfg Plant:		Mech. Spec:		Layout:	611741-694
Frame:	364T	Mounting:	W7	Poles:	04	Created Date:	11-18-2010
Base:		Rotation:	R	Insulation:	F	Eff. Date:	12-06-2016
Leads:	3#4,6#6					Replaced By:	
Literature:		Elec. Diagram:					

Nameplate NP2422L									
SPEC NO.	B678921	CAT.NO.		FRAME	364T				
HP	60	VOLTS	230/460	PHASE	3	DESIGN	B	TYPE	P
RPM	1780	AMPS	136/68	HZ	60	AMB	40	SF	1.15
DRIVE END BEARING	65BC03JGG30A	DUTY	CONT	INSUL.CLASS	F				
OPP D.E. BEARING	65BC03JGG30A	ENCL	TEAO	CODE	G				
SER.NO.									
	10-429P								
	MOTOR WEIGHT 867								

Parts List		
Part Number	Description	Quantity
SA211778	SA B678921	1.000 EA
RA199007	RA B678921	1.000 EA
000613006PU	N/P (RELEASE QTY 10,000) UL CSA LABEL	1.000 EA
000692000CY	N/P	1.000 EA
000692000VD	LABEL WARNING	1.000 EA
NP2422L	E-PACT XT, EXTRA TOUGH IEEE-45, SS,	1.000 EA
004824003CAB	WILKO PAINT 772.61	0.250 GA
033775004EA	DRSCR #6-1/4 304 S.S.	4.000 EA
004824015A	GREASE POLYREX EM	1.000 LB
032018010CK	HHCS 3/8-16X1-1/4 PLTD.	4.000 EA
032018012DK	HHCS 1/2-13X1-1/2 PLTD.	2.000 EA
032018012DK	HHCS 1/2-13X1-1/2 PLTD.	4.000 EA
032018024CK	HHCS 3/8-16X3 PLTD.	3.000 EA
032018024CK	HHCS 3/8-16X3 PLTD.	3.000 EA
085922073B	BRKT 360 085922072WCC KB	1.000 EA
033512008LB	HHTTS 1/4-20X1 PLATED	4.000 EA
034000014AB	WSH ID.406 OD.812 TH.065	4.000 EA
034180034HA	KEY 5/8X5/8X4-1/4 L	1.000 EA
034690001AB	SQHDPLG, COND	1.000 EA
034690001AB	SQHDPLG, COND	1.000 EA
034690002AB	"unbulked" PPLG 1/4" PLTD.	1.000 EA
034690002AB	"unbulked" PPLG 1/4" PLTD.	1.000 EA
085922073B	BRKT 360 085922072WCC KB	1.000 EA
048897010DG	PLUG,ODE BRKT - 360	1.000 EA

Parts List (continued)		
Part Number	Description	Quantity
065776000C	TERBD 320-400	1.000 EA
067053000B	GASK 320-400	1.000 EA
076708000BB	C/B - 360	1.000 EA
076709000A	C/B - 360	1.000 EA
410700004F	WSHR	1.000 EA
415000103D	T/LUG #4AWG-1/0AWG W/HOLE FOR .250 BOLT	1.000 EA
418150003A	GREASE FITTING CAP	1.000 EA
415038029A	250/280 MOUNTING BRKT	1.000 EA
415038029B	250/280 MOUNTING BRKT	1.000 EA
034017018AB	LCKW 5/8"	2.000 EA
033102018AG	NUT 5/8-11 PLATED	2.000 EA
032018012EK	HHCS 5/8-11X1-1/2L PLTD.	2.000 EA
HW4600G56	DOME SLINGER, 7.875 OD X 2.370/2.300 ID	1.000 EA
415045002E	SLGR	1.000 EA
418151057A	PLASTIC DRAIN,ODE BRKT	1.000 EA
034690001AB	SQHDPLG, COND	1.000 EA
421948032	LABEL, MYLAR	1.000 EA
604797064C	2"X4"-24"	2.000 EA
034600035AA	BUSH 3 TO 2-1/2 BLACK	1.000 EA
000692000FF	N/P	1.000 EA
415034014J	SPSCR	2.000 EA
604797064C	2"X4"-24"	1.000 EA
604797064C	2"X4"-24"	1.000 EA
604797064C	2"X4"-24"	1.000 EA

Product Information Packet: B678921 - 60HP,1780RPM,3PH,60HZ,364T,A36062M,TEAO

033512004LB	HHTTS 1/4-20X1/2 PLTD.	1.000 EA
-------------	------------------------	----------

REL. S.O.	FRAME	HP	TYPE	PHASE/HERTZ	RPM	VOLTS
	364T	60	P	3/60	1780	230/460
AMPS	DUTY	AMB °C/ INSUL.	S.F.	NEMA DESIGN	CODE LETTER	ENCL.
136/68	CONT	40/F	1.15	B	G	TEAO
E/S	ROTOR	TEST S.O.	TEST DATE	TEST DATE	STATOR RES. @25 °C OHMS (BETWEEN LINES)	
492281	418141035YE	---	---	---	.0277/.110	

PERFORMANCE

LOAD	HP	AMPERES	RPM	POWER FACTOR	% EFFICIENCY
NO LOAD	0	20.1	1800	4.67	0
1/4	15.0	25.8	1795	58.6	93.0
2/4	30.0	37.5	1791	78.7	95.2
3/4	45.0	51.9	1786	85.0	95.3
4/4	60.0	68.0	1781	87.0	95.0
5/4	75.0	85.1	1775	87.5	94.3

SPEED TORQUE

	RPM	TORQUE % FULL LOAD	TORQUE LB.-FT.	AMPERES
LOCKED ROTOR	0	181	320	430
PULL UP	720	161	285	395
BREAKDOWN	1703	251	445	244
FULL LOAD	1781	100	177	68.0

AMPERES SHOWN FOR 460. VOLT CONNECTION. IF OTHER VOLTAGE CONNECTIONS ARE AVAILABLE, THE AMPERES WILL VARY INVERSELY WITH THE RATED VOLTAGE

REMARKS: TYPICAL DATA
 XE MOTOR-NEMA NOM. EFF. 95.0 %
 GUARANTEED MIN. EFF. 94.5%

BALDOR	DR. BY	D. M. BYRD	A-C MOTOR
	CK. BY	J. P. TSAO	
	APP. BY	J. P. TSAO	PERFORMANCE DATA
	DATE	10/10/91	ISSUE DATE 12/15/10

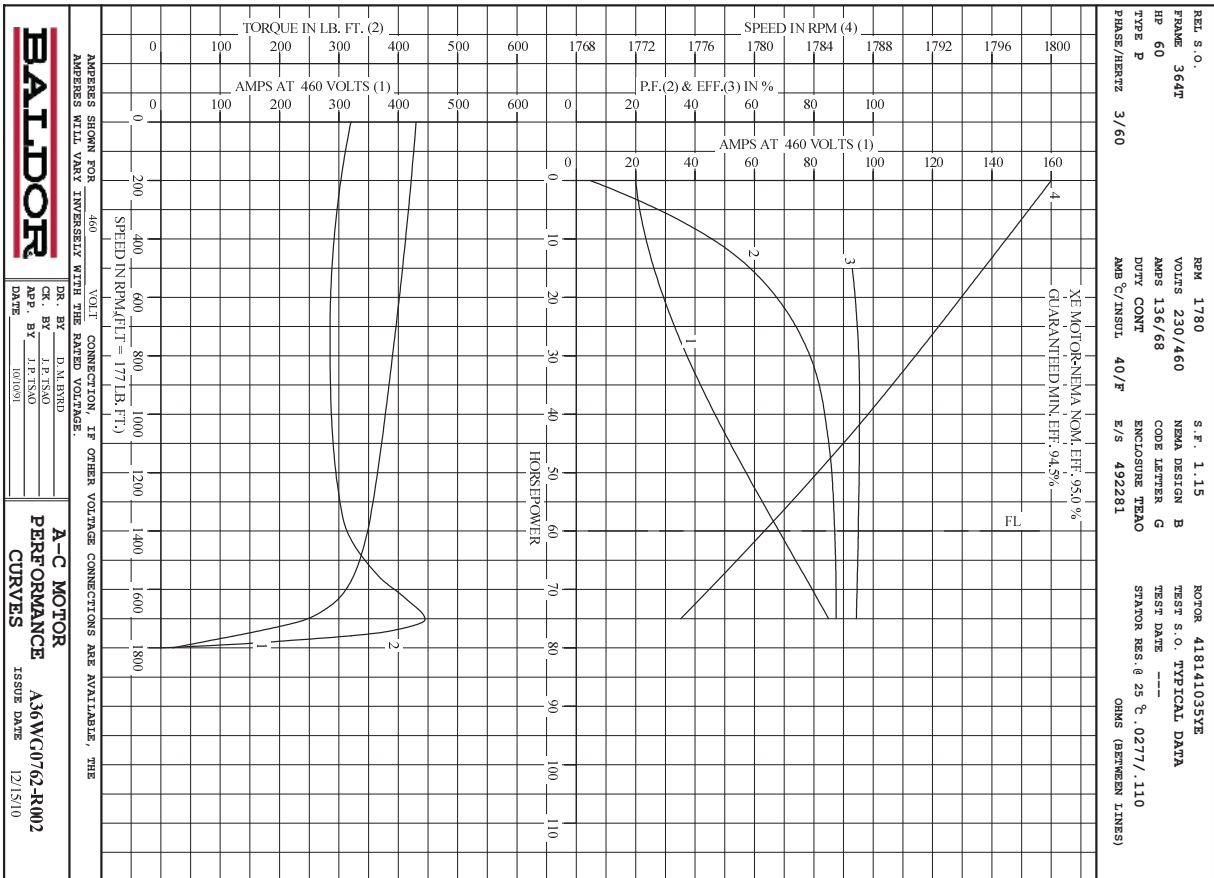

Printed on 12/15/10 9:29 @ psec-motorseng

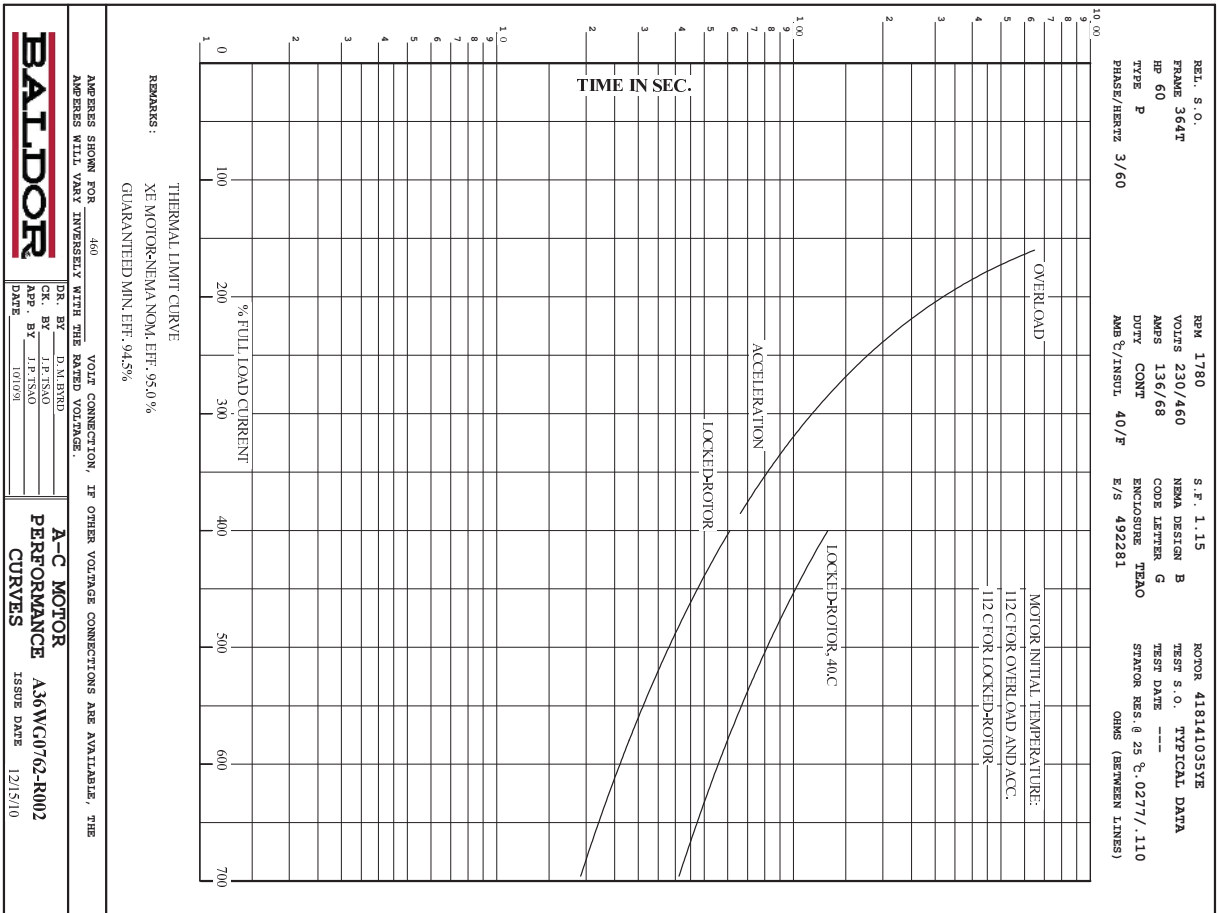

416820-002

A-C MOTOR
 CONNECTION DIAGRAM
 STANDARD 9 LEAD DELTA-CONNECTED

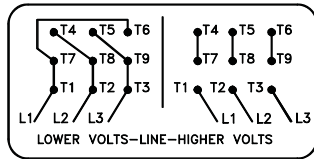
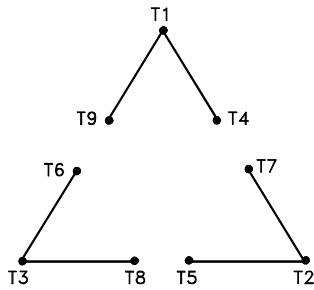

(N.P. 1575-B)

416820-002

REV. DESC: LOADED TO BUS, C/R 335225		
REV. LTR: -	VERSION: 00	TDR: 000000538207
FILE: \MGA\00000\661	REVISED: 10: 47: 51 04/30/2010	
MTL: -	BY: RAGRA	

BALDOR

CONN DIAG - STANDARD 9 LEAD, DELTA-CONNECTED
 SH 1 of 1

Features

- Pilot operated, normally open or normally closed
- Snubber slows disc closing speed to protect system against water hammer damage more effectively than other techniques
- Pressure spike due to water hammer is reduced to a point eliminating the need for suppressors or other controls in most water systems
- Fluid Controls Institute Inc. evaluations have classified these valves:

Pipe Sizes	FCI-82-1 Class
3/8", 1/2", 3/4"	CC
1", 1 1/4", 1 1/2", 2" , 2 1/2"	BB

Construction

Valve Parts in Contact with Fluids	
Body	Brass
Disc	NBR
Seals	PTFE & NBR
Core Tube	305 Stainless Steel
Core and Plugnut	430F Stainless Steel
Springs	302 Stainless Steel
Piston	Stainless Steel or Brass
Shading Coil	Copper

Electrical

Standard Coil and Class of Insulation	Watt Rating and Power Consumption				Spare Coil Part No.			
	DC Watts	AC			General Purpose		Explosionproof	
		Watts	VA Holding	VA Inrush	AC	DC	AC	DC
F	11.6	6.1	16	30	238210	238710	238214	238714
F	16.8	16.1	35	95	272610	97617	272614	97617
F	22.6	-	-	-	-	238710	-	238714

Standard Voltages: 24, 120, 240, 480 volts AC, 60 Hz (or 110, 220 volts AC, 50 Hz).
 6, 12, 24, 120, 240 volts DC. Must be specified when ordering.
 Other voltages are available when required.

Solenoid Enclosures

Standard: RedHat II - Watertight, Types 1, 2, 3, 3S, 4, and 4X; RedHat - Type I.

Optional: RedHat II - Explosionproof and Watertight, Types 3, 3S, 4, 4X, 6, 6P, 7, and 9; RedHat - Explosionproof and Raintight, Types 3, 7, and 9. (To order, add prefix "EF" to catalog number.)

See *Optional Features Section* for other available options.

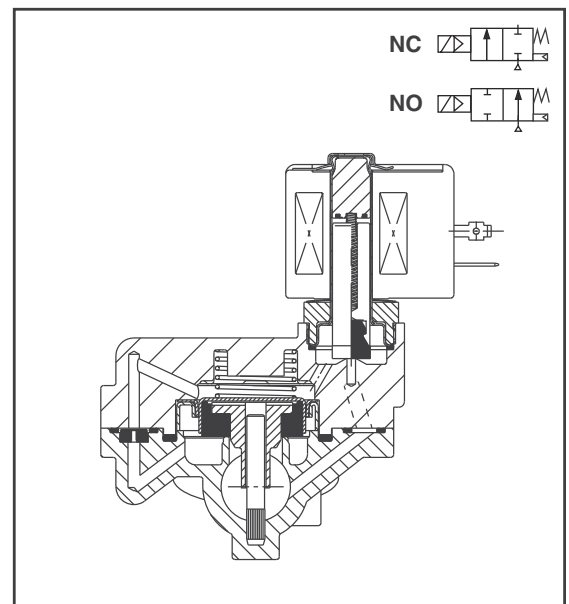

Nominal Ambient Temp. Ranges:

- RedHat II/ RedHat AC: 32°F to 125°F (0°C to 52°C)
- RedHat II DC: 32°F to 104°F (0°C to 40°C)
- RedHat DC: 32°F to 77°F (0°C to 25°C) (104°F/40°C occasionally)

Refer to *Engineering Section* for details.

Approvals:

CSA certified. UL listed, General Purpose Valves. RedHat II meets applicable CE directives. Refer to *Engineering Section* for details.

Specifications (English units)

Pipe Size (ins.)	Orifice Size (ins.)	Cv Flow Factor	Operating Pressure Differential (psi)			Max. Fluid Temp. °F		Brass Body Catalog Number	Const. Ref.	Watt Rating/ Class of Coil Insulation ③	
			Min. ①	Max. AC	Max. DC	AC	DC			AC	DC
				Water ②	Water ②						
NORMALLY CLOSED (Closed when de-energized)											
3/8	9/16	3	5	150	125	180	150	8221G001	1	6.1/F	11.6/F
1/2	9/16	3.5	5	150	125	180	150	8221G003	1	6.1/F	11.6/F
3/4	3/4	5.5	5	150	125	180	150	8221G005	2	6.1/F	11.6/F
1	1	11.5	5	150	125	180	150	8221G007	5	6.1/F	11.6/F
1 1/4	1 1/8	13	5	150	125	180	150	8221G009	6	6.1/F	11.6/F
1 1/2	1 1/4	24	5	150	125	180	150	8221G011	7	6.1/F	11.6/F
2	1 3/4	36	5	150	125	180	150	8221G013	11	6.1/F	22.6/F
2 1/2	1 3/4	38	5	150	125	180	150	8221G015	12	6.1/F	22.6/F
NORMALLY OPEN (Open when de-energized)											
3/8	9/16	3	5	-	125	-	150	8221 021	15	-	16.8/F
3/8	9/16	3	5	150	-	180	-	8221G021	3	16.1/F	-
1/2	9/16	3.5	5	-	125	-	150	8221 023	15	-	16.8/F
1/2	9/16	3.5	5	150	-	180	-	8221G023	3	16.1/F	-
3/4	3/4	5.5	5	-	125	-	150	8221 025	16	-	16.8/F
3/4	3/4	5.5	5	150	-	180	-	8221G025	4	16.1/F	-
1	1	11.5	5	-	125	-	150	8221 027	17	-	16.8/F
1	1	11.5	5	150	-	180	-	8221G027	8	16.1/F	-
1 1/4	1 1/8	13	5	-	125	-	150	8221 029	18	-	16.8/F
1 1/4	1 1/8	13	5	150	-	180	-	8221G029	9	16.1/F	-
1 1/2	1 1/4	24	5	-	125	-	150	8221 031	19	-	16.8/F
1 1/2	1 1/4	24	5	150	-	180	-	8221G031	10	16.1/F	-
2	1 3/4	36	5	-	125	-	150	8221 033	20	-	16.8/F
2	1 3/4	36	5	150	-	180	-	8221G033	13	16.1/F	-
2 1/2	1 3/4	38	5	-	125	-	150	8221 035	21	-	16.8/F
2 1/2	1 3/4	38	5	150	-	180	-	8221G035	14	16.1/F	-

① Valves require a 5 psi Minimum Pressure Differential to open. Once open, they remain open with 3 psi differential pressure.
 ② Refer to Steam/Hot Water Valve Series for Hot Water constructions.
 ③ On 50 hertz service, the watt rating for the 6.1/F solenoid is 8.1 watts.

Response time upon energization: 3/8" - 1/2" (2-4 seconds), 3/4" - 1 1/4" (4-8 seconds), 1 1/2" - 2 1/2" (8-10 seconds)

Dimensions: inches (mm)

Const. Ref.	H	K	L	P	W
1	ins. 4.34	2.69	2.72	3.59	3.41
	mm 110	68	69	91	87
2	ins. 4.53	2.69	2.78	3.75	3.41
	mm 115	68	71	95	87
3	ins. 5.22	3.14	2.72	4.47	3.69
	mm 133	80	69	114	94
4	ins. 5.41	3.30	2.78	4.62	3.69
	mm 137	84	71	117	94
5	ins. 5.62	3.15	3.75	4.03	3.16
	mm 143	80	95	102	80
6	ins. 5.56	3.15	3.66	4.03	3.56
	mm 141	80	93	102	90
7	ins. 6.12	3.30	4.38	4.19	4.12
	mm 156	84	111	106	105
8	ins. 6.53	3.59	3.75	4.91	3.16
	mm 166	91	95	125	80
9	ins. 6.47	3.59	3.56	4.91	3.56
	mm 164	91	93	125	90
10	ins. 7.03	3.74	4.38	5.06	4.12
	mm 179	95	111	129	105
11	ins. 7.38	3.71	5.06	4.59	4.72
	mm 188	94	129	117	120
12	ins. 7.38	3.71	5.50	4.59	5.19
	mm 188	94	140	117	132
13	ins. 8.22	4.15	5.06	5.47	4.72
	mm 209	105	129	139	120
14	ins. 8.22	4.15	5.50	5.47	5.19
	mm 209	105	140	139	132
15	ins. 5.22	-	2.72	4.47	3.69
	mm 133	-	69	114	94
16	ins. 5.41	-	2.78	4.62	3.69
	mm 137	-	71	117	94
17	ins. 6.53	-	3.75	4.91	3.16
	mm 166	-	95	125	80
18	ins. 6.47	-	3.66	4.91	3.56
	mm 164	-	93	125	90
19	ins. 7.03	-	4.38	5.06	4.12
	mm 179	-	111	129	105
20	ins. 8.22	-	5.06	5.47	4.72
	mm 209	-	129	139	120
21	ins. 8.22	-	5.50	5.47	5.19
	mm 209	-	140	139	132

IMPORTANT: Valves may be mounted in any position.

Const. Ref. 1, 2

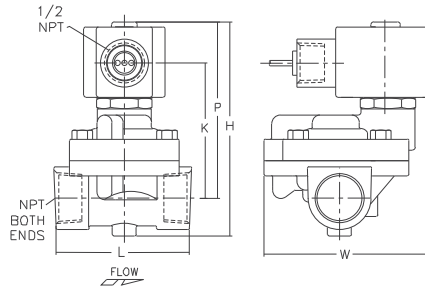

Const. Ref. 3, 4

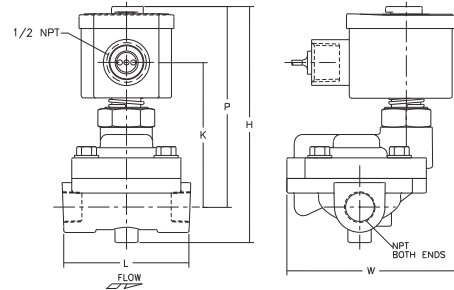

Const. Ref. 5, 6

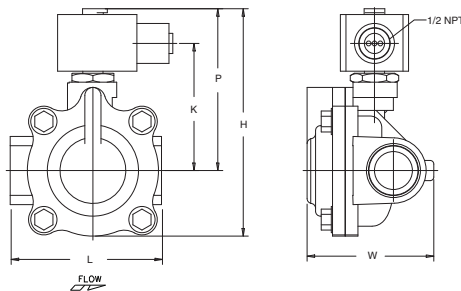

Const. Ref. 7, 11, 12

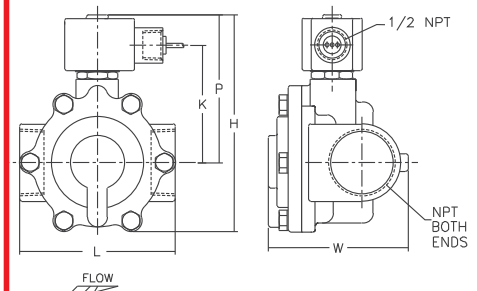

Const. Ref. 8, 9, 10, 13, 14

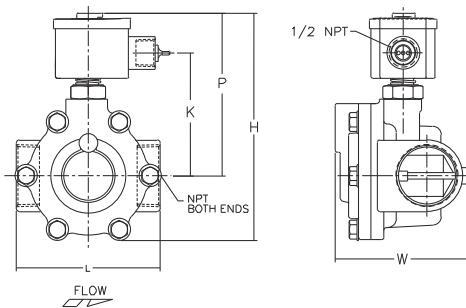

Const. Ref. 15, 16

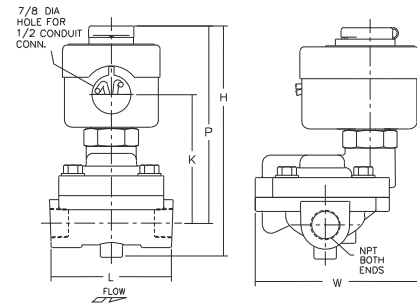

Const. Ref. 17 - 21

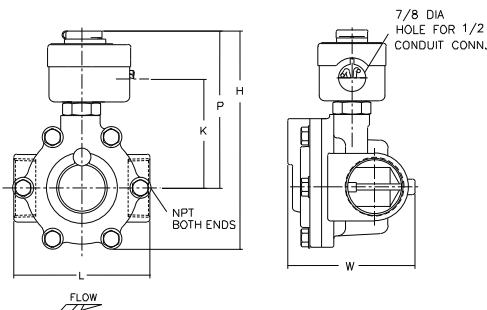



Certificate of Compliance

AT, USS, UAT, UT Cooling Towers
eco-ATWB/WB-E, ATWB and ESWA Closed Circuit Coolers
eco-ATC, ATC-E Evaporative Condensers

Are certified to meet or exceed the Seismic and Wind Load Provisions
set forth in the applicable building codes for this project.

These products have been manufactured following all
applicable quality assurance programs.

Applicable Building Codes:

IBC 2012
ASCE-7
NFPA 5000

Referenced Report:

VMA-43387

Approval Agency:

VMC Seismic Consulting Group



EVAPCO...Specialists in Heat Transfer Products and Services.

ID IBC COC 001



Guarantee of Thermal Performance

EVAPCO® unequivocally guarantees the thermal performance of its equipment as shown on the certified drawings, when the equipment is installed in accordance with good engineering practice. If after installation and start-up there is any question regarding thermal performance of the equipment, at the owner's request EVAPCO will send its engineers to the jobsite to conduct a performance test. This test may be observed by the owner and the consulting engineer or by their authorized representatives. If the results of the evaluation show the equipment to be deficient, EVAPCO will make the necessary repairs or alterations to correct the deficiency at no cost to the owner. If the equipment is found to be performing in accordance with its certified drawing, the owner is expected to reimburse the company for its costs associated with this performance test. This guarantee is subject to all conditions and limitations set forth in the express warranty that applies to the equipment.



EVAPCO...Specialists in Heat Transfer Products and Services.

