

**Available For
Quick Delivery**



**Bronze and
Stainless Steel
2-Way**

SOLENOID VALVES

For Control Of
**WATER • OIL • STEAM
AIR • GAS • CRYOGENICS
SOLVENTS • OXYGEN
CORROSIVE FLUIDS**





WELCOME TO MAGNATROL

Process Control Solenoid Valves For

Water • Oil • Air • Gas • Steam • Cryogenics • Vacuum • Solvents • Brine • Oxygen • Corrosive Fluids



Magnatrol Valve Corp.

- Established 1936
- Experienced Dedicated Sales Staff
- Application / Engineering Assistance
- Excellent Product Support
- Quick Delivery

Our continued success has come from manufacturing a top quality product, product support, commitment to service and on-time delivery assuring complete customer satisfaction.

Our Products

Every valve is manufactured and tested in-house following Quality Assurance Standards where production operations are under the control of our dedicated, experienced staff and workforce.

- High Quality Bronze and Stainless Steel Solenoid Valves*
- Pressures up to 500 PSI *
- Temperatures up to 400° F *
- Cryogenic and Oxygen Service Applications
- Normally Closed (Energize to Open)
- Normally Open (Energize to Close)
- Continuous Duty Coils for all AC & DC Voltages
- NO Differential Pressure Required to Open
- Full Port-Internal Pilot Operated or Direct Acting
- 2-Way Straight Thru Design
- Packless Construction

TABLE OF CONTENTS	
Category	Pages(s)
Coils.....	4
Construction Features.....	5
Bronze Valves	
N & NR.....	6 & 7
A & AR.....	8 & 9
M & MR.....	10 & 11
S & SR.....	12 & 13
L & LR.....	14 & 15
G & GR.....	16 & 17
D.....	18
Strainers.....	19
Stainless Steel Valves	
J & JR.....	20 & 21
K & KR.....	22 & 23
W & WR.....	24 & 25
Optional Features.....	26 & 27
Special Valves	
Universal Mount "P".....	28
Sandy Well Water.....	29
Gritty Coolant.....	30 & 31
Ordering Information.....	32 & 33
Terms & Conditions/Contact Info.....	34

* **Custom Engineered Valves**, Special Alloys, Temperatures, Pressures and Applications as well as Modifications to Standard Magnatrol Valves are available through Magnatrol's **Clark-Cooper Division**. (See bottom of page 3)





VALVE SELECTION CHART

Ordering Information - See Pages 32 & 33
For Optional Features - See Pages 26 & 27

VALVE SELECTION CHART

(For Fluids/Gases Not Listed And For Special Applications, Consult Factory)

Max . Temperature	Up To 212°F				Up To 400°F					
Construction	Bronze							Stainless Steel		
Valve Type	D	G/GR	N/NR	A/AR	M/MR	S/SR	L/LR	K/KR	W/WR	
Page	18	16 & 17	6 & 7	8 & 9	10 & 11	12 & 13	14 & 15	20 & 21	22 & 23	
Max. Diff. Pressure	30 PSI	50 PSI	300 PSI	500 PSI	150 PSI	180 PSI	500 PSI	500 PSI	180 PSI	
Pipe Size Inches	3/8"-2"	1"-3"	1/2"-3/4"	1/2"-3"	3/8"-3/4"	1/2"-3"	1/2"-3"	1/2"-3"	1/2"-3"	
Internal Port Size	Full	Full	Reduced	Full	Reduced	Full	Full	Full	Full	
Air	◆	◆	◆	◆	◆		◆	◆		
Brine			◆	◆	◆		◆	◆		
Gas	◆	◆		◆	◆		◆	◆		
Oil	◆		◆	◆	◆		◆	◆		
Solvents	◆	◆	◆	◆	◆		◆	◆		
Water	◆	◆	◆	◆	◆		◆	◆		
Vacuum	◆	◆	◆	◆						
Steam					◆	◆			◆	
Cryogenic					◆		◆	◆		
Oxygen, Liquid					◆		◆	◆		
Oxygen, Gaseous	◆	◆		◆			◆	◆		
Corrosive								◆		

Use the chart above to determine suitable types of Magnatrol valves for a given application.

Example: A normally closed 1/2" valve for use on 100 psi steam, there are three types suitable and the final selection can only be made after referring to Bulletins 3006-M, 3006-S and 3006-W on pages 10, 12 and 22 respectively.

Maximum Differential Pressure:

When specifying a valve, the Maximum Differential Pressure must be equal to or greater than the application. Care should be taken not to "over specify" the valve by choosing a valve with a Maximum Differential Pressure that is excessively beyond the application.

If you are unsure please consult the factory.

For Custom Engineered Valves,
modifications to standard Magnatrol valves and valves that fall outside standard valve capabilities,
contact Magnatrol's Clark Cooper Division

2-Way and 3-Way • 1/4" Thru 6"

- Pressures to 10,000
- Fluid Temperatures up to 550°F
- Dirty / Viscous & Corrosive Fluids
- Bronze, 316SS, Monel, Alloy 20 & Hastelloy
- End connections: NPT, Flange, Union, Socket Weld, Butt Weld, Pipe Nipples etc.
- Options: Remote Trip with Manual or Automatic Reset and many others

3-Valve
Manifold for
CNG Refueling



High Pressure
Cartridge Valve
10,000 PSI



3-Way Trip Valve with 2 Position
Indicating Switches
and Manual Reset

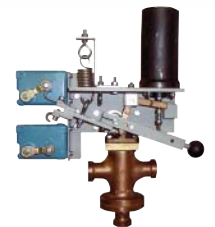

CLARK - COOPER DIV.
 855 INDUSTRIAL HIGHWAY - #4
 CINNAMINSON, NJ 08077

Phone: 856 - 829 - 4580 • Fax: 856 - 829 - 7303
 Email: techsupport@clarkcooper.com
 Web: www.clarkcooper.com

MAGNATROL VALVE CORPORATION



SOLENOID COILS CONTINUOUS DUTY COILS

ELECTRICAL CHARACTERISTICS

Coils are stocked for the following voltages:

Voltage	6	12	24	32	48	64	75	120	208	240	480	575
50, 60 Hertz AC			•					•	•	•	•	•
DC	•	•	•	•	•	•	•	*		*		

75V DC for locomotive applications * Furnished with surge protecting capacitor

Reference should be made to the Bulletins to determine the availability of a required valve for a specific power supply.

Consult the factory for information regarding voltage and frequencies not listed.



ENCAPSULATED COIL

Valves for A.C. service can be converted for use on other A.C. voltages simply by changing the coil. Similarly D.C. valves can be converted for other D.C. voltages. Consult factory regarding conversion from A.C. to D.C. or D.C. to A.C.

CURRENT CONSUMPTION:

Current values shown in the bulletins are for 120 volts, 60 hertz. For other voltages the current is inversely proportional: For instance, if a given valve draws 0.5 amperes on 120 volts it would draw 0.25 amperes on 240 volts, or 0.125 amperes on 480 volts. Where power consumption is shown in D.C. watts, the values given should be divided by line voltage to obtain the current in amperes. Power consumption for all valves is shown in the individual bulletins.

CONSTRUCTION:

Continuous Duty Construction: Coils can be energized continuously without overheating or failure.

Wire Leads: 18" long 18 gauge wire standard (longer continuous leads available)

Encapsulated: Coils are encapsulated for temperature of intended service, providing excellent resistance to shock, moisture, oil and chemicals

COIL CLASS:

GENERAL SERVICE - CLASS "B"		HIGH TEMPERATURE - CLASS "H"	
Maximum Fluid Temperature	Maximum Ambient Temperature	Maximum Fluid Temperature	Maximum Ambient Temperature
212° F (100° C)	140° F (60° C)	300° F (150° C)	212° F (100° C)

INSTALLATION:

The coil is a two wire device which may be controlled by either a single or double pole switch. The switch should always be installed in the hot leg of 120 volt circuits. Where both legs are hot, such as 240 or 480 volt circuits, a double pole switch is preferable, however, if a single pole switch is used, then the wiring should have top quality insulation since even minute leakage currents may give rise to sticking problems. On motor hookup with step control starter, full voltage should be supplied to coil immediately.

Note: Coil can be readily changed while valve is still under pressure.

VALVE CONSTRUCTION FEATURES



Valve Construction Features:

- 2-way straight thru globe design
- Bronze or Stainless Steel body w/ female NPT threads standard
- Stainless Steel available with 150# and 300# flanged ends
- Full port-internal pilot operated or direct acting
- Packless construction
- Continuous duty coils for all voltages
- No differential pressure required to open

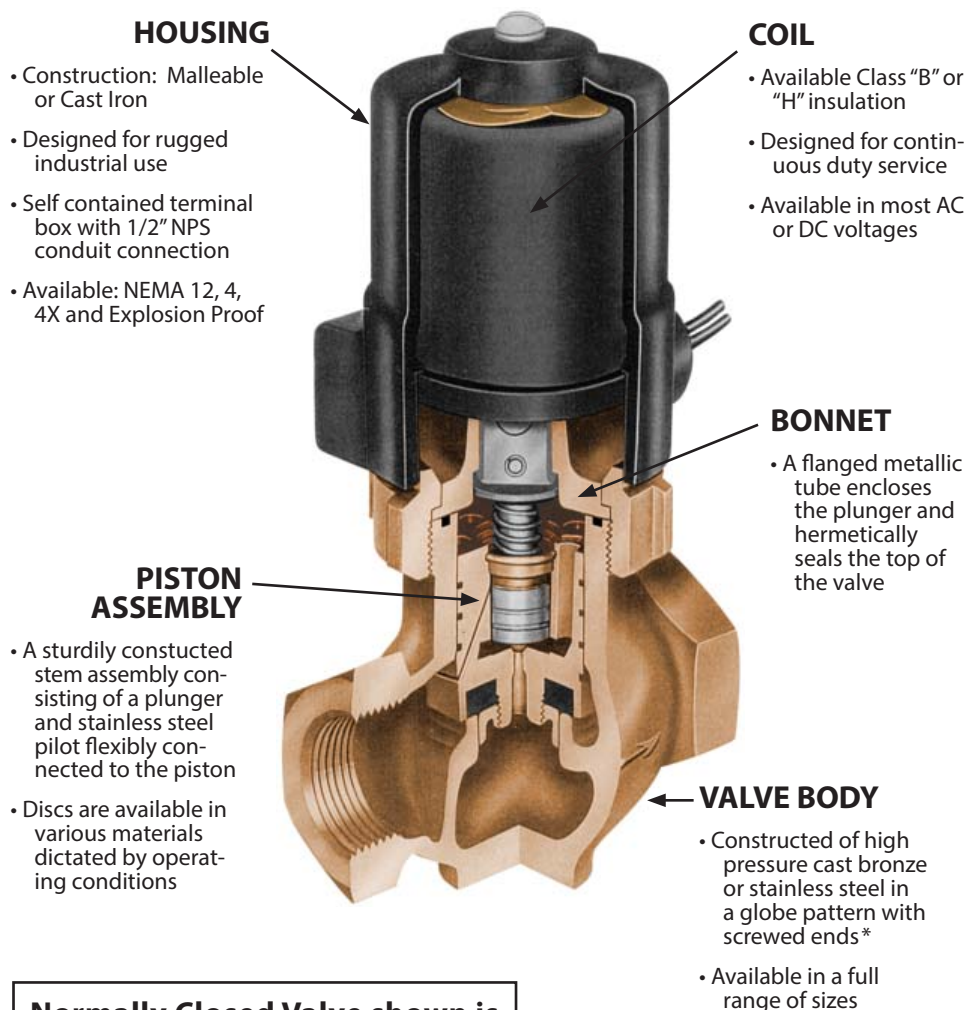

Normally Closed Valve shown is typical of Type A, 1/2" thru 1-1/4"

* Stainless Steel valves available with flanged ends. Flanged Bronze valves available through Magnatrol's Clark-Cooper Division (See bottom of

Easy In-Line Service

Inspect, clean or service all internal parts of full port-internal pilot operated or direct acting solenoid valves while the valve body remains in the pipeline shortening costly down time and increasing productivity.

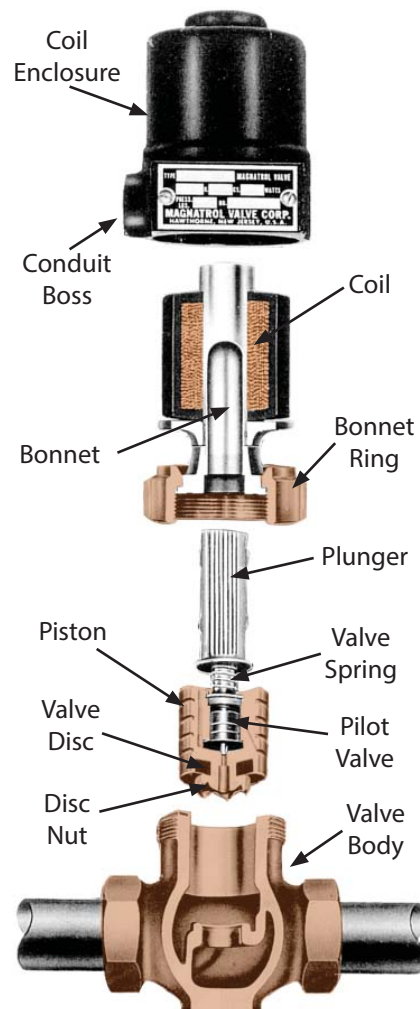

MAGNATROL SOLENOID OPERATED VALVES are used to control the flow of liquids or gases, generally in conjunction with automatic control apparatus such as thermostat, float switch, time switch, or flow meter.

MAGNATROL VALVE CORPORATION



BRONZE SOLENOID VALVES

Dependable • Packless

TYPE "N" - NORMALLY CLOSED 1/2" TO 3/4" PIPE SIZE

NO DIFFERENTIAL PRESSURE REQUIRED TO OPEN

DIRECT ACTING - ORIFICE SIZES 3/32" TO 1/2"

OPERATION:

Valve opens when energized and closes when de-energized. In this direct acting valve, when the coil is energized, the stem is lifted from its conical seat by the plunger.

CONSTRUCTION: (* Wetted parts)

- *Valve Body - Cast Bronze, Globe Pattern - NPT ends
- Coil Enclosure - Malleable Iron, 1/2" NPS conduit conn.
- *Plunger - 430 Stainless Steel
- *Valve Stem - 303 Stainless Steel
- *Bonnet Tube - 304 Stainless Steel
- *Spring - 302 Stainless Steel
- *Body Seal - Buna N
- *Orifice Seal - Metal to Metal
- *AC Shading Coil - Copper
- *Stem Pin - Inconel
- Coil - Encapsulated Class B, 18" leads - (Class H available)

APPLICATION:

To control the flow of **Water, Oil, Air, Gas, Solvents, Brine, Vacuum** and any other fluids not reactive with construction materials and free of sediment. Valve operates from zero to maximum differential pressure indicated in table. Valve must be mounted in horizontal pipe with solenoid enclosure vertical and on top.

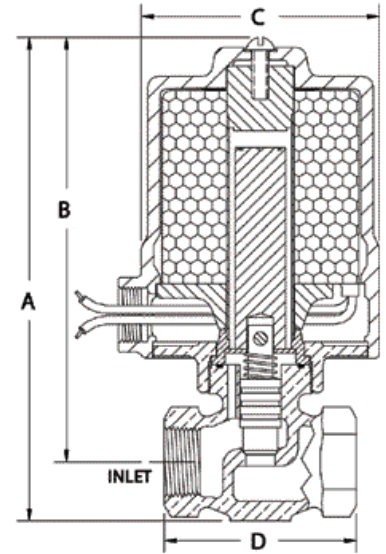

MAX. FLUID TEMP.
212° F
MAX. STATIC PRESSURE
300 PSI



FOR OPTIONS & ACCESSORIES
SEE PAGES 26 & 27

Pipe Size Inches	Max. Diff. PSI	Valve Port Size	Type No.	Watts AC	Amps Hold 120-60	Amps Inrush 120-60	Watts DC	Ship Wt. Lbs.	Dimensions In Inches			
									A	B	C	D
3/8	DISCONTINUED -- USE 1/2" VALVE WITH BUSHING											
1/2	25	3/8	18N22	25	0.4	1.2	18	6	6-1/4	5-3/8	2-3/4	2-3/4
	50	1/4	18N42									
	75	3/16	18N52									
	100	5/32	18N82									
	150	1/8	18N62									
	225	3/32	18N72									
	50	3/8	33N22	45	0.8	2.4	23	10	7-1/8	6-3/8	3-1/2	2-3/4
	75	5/16	33N32									
	100	1/4	33N42									
	150	3/16	33N52									
300	1/8	33N62										
3/4	15	1/2	18N13	25	0.4	1.3	18	7	6-1/2	5-5/8	2-3/4	2-7/8
	35	5/16	18N33									
	30	1/2	33N13	45	0.8	2.5	23	10	7-3/8	6-1/2	3-1/2	2-7/8
	75	5/16	33N33									

Strainers are recommended for use with solenoid valves (See page 19)

When you order please supply the following:

- Pipe Size
 - Valve Type
 - Voltage (AC or DC)
 - Hertz
 - Fluid
 - Fluid Temperature
 - Max. Diff. Pressure
 - Optional Features
- (See pages 26 & 27)

Optional "Soft Seat" Orifice Seal (for applications requiring tight seating)
Viton - Suitable for Fuel Oils, Gaseous Oxygen and other compatible fluids

MAGNATROL VALVE CORPORATION

BRONZE SOLENOID VALVES

Dependable • Packless



TYPE "NR" - NORMALLY OPEN

1/2" TO 3/4" PIPE SIZE

NO DIFFERENTIAL PRESSURE REQUIRED TO OPEN

DIRECT ACTING - ORIFICE SIZES 3/32" TO 1/2"

OPERATION:

Valve closes when energized and opens when de-energized. In this direct acting valve, when the coil is energized, the stem is pressed into its conical seat by the plunger.

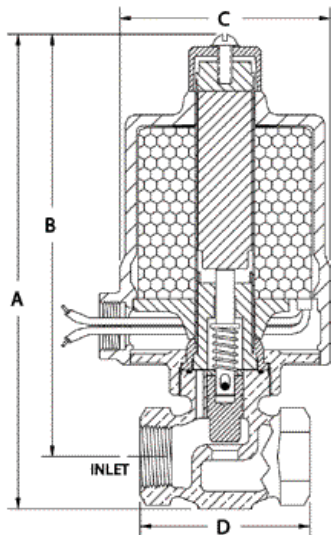

CONSTRUCTION: (* Wetted parts)

- *Valve Body - Cast Bronze, Globe Pattern - NPT ends
- Coil Enclosure - Malleable Iron, 1/2" NPS conduit conn.
- *Plunger - 430 Stainless Steel
- *Poppet - 304 Stainless Steel
- *Stem - 303 Stainless Steel
- *Bonnet Tube - 304 Stainless Steel
- *Spring - Inconel
- *Body Seal - Buna N
- *Orifice Seal - Metal to Metal
- *AC Shading Coil - Copper
- *Stem Pin - 304 Stainless Steel
- Coil - Encapsulated Class B, 18" leads - (Class H available)

APPLICATION:

To control the flow of **Water, Oil, Air, Gas, Solvents, Brine, Vacuum** and any other fluids not reactive with construction materials and free of sediment. Valve operates from zero to maximum differential pressure indicated in table. Valve must be mounted in horizontal pipe with solenoid enclosure vertical and on top.



**FOR OPTIONS & ACCESSORIES
SEE PAGES 26 & 27**

Strainers are recommended for use with solenoid valves
(See page 19)

When you order please supply the following:

- Pipe Size
- Valve Type
- Voltage (AC or DC)
- Hertz
- Fluid
- Fluid Temperature
- Max. Diff. Pressure
- Optional Features

(See pages 26 & 27)

Pipe Size Inches	Max. Diff. PSI	Valve Port Size	Type No.	Watts AC	Amps Hold 120-60	Amps Inrush 120-60	Watts DC	Ship Wt. Lbs.	Dimensions In Inches			
									A	B	C	D
3/8	DISCONTINUED -- USE 1/2" VALVE WITH BUSHING											
1/2	23	3/8	18NR22	25	0.5	1.5	18	7	7	6-1/8	2-3/4	2-3/4
	45	1/4	18NR42									
	70	3/16	18NR52									
	90	5/32	18NR82									
	135	1/8	18NR62	45	1.0	2.7	23	10	7-7/8	7-1/8	3-1/2	2-3/4
	200	3/32	18NR72									
	45	3/8	33NR22									
	70	5/16	33NR32									
90	1/4	33NR42	25	0.5	1.6	18	7	7-1/4	6-3/8	2-3/4	2-7/8	
135	3/16	33NR52										
270	1/8	33NR62										
3/4	13	1/2	18NR13	45	1.0	2.8	23	10	8-1/8	7-1/4	3-1/2	2-7/8
	32	5/16	18NR33									
	27	1/2	33NR13									
	70	5/16	33NR33									

Optional "Soft Seat" Orifice Seal (for applications requiring tight seating)
Viton - Suitable for Fuel Oils, Gaseous Oxygen and other compatible fluids

MAGNATROL VALVE CORPORATION



BRONZE SOLENOID VALVES

Dependable • Packless

TYPE "A" FULL PORT - NORMALLY CLOSED

1/2" TO 3" PIPE SIZE

NO DIFFERENTIAL PRESSURE REQUIRED TO OPEN

MAX. FLUID TEMP.
212° F
MAX. STATIC PRESSURE
300 PSI
 Except valves listed for 500 PSI

OPERATION:

Valve opens when energized and closes when de-energized. When the coil is energized the pilot valve opens, relieving the pressure above the piston, which is then lifted from its seat by the plunger. Upon de-energizing the coil, a spring closes the pilot valve and opens a bleed passageway to permit pressure to build above the piston and seat it.

CONSTRUCTION: (* Wetted parts)

- *Valve Body - Cast Bronze, Globe Pattern - NPT ends
- *Piston - Bronze
- Coil Enclosure - Malleable or Cast Iron, 1/2" NPS conduit conn.
- *Plunger - 430 Stainless Steel
- *Pilot Valve - 303 Stainless Steel
- *Bonnet Tube - 304 Stainless Steel
- *Spring - 302 Stainless Steel
- *Body Seal - Buna N or Non Asbestos Gasket
- *Orifice Seal - Buna N (Viton or Glass Filled Teflon available)
- *AC Shading Coil - Copper
- *Stem Pin - Inconel
- Coil - Encapsulated Class B, 18" leads - (Class H available)

APPLICATION:

To control the flow of Water, Oil, Air, Gas, Solvents, Brine, Vacuum and any other fluids not reactive with construction materials and free of sediment. Valve operates from zero to maximum differential pressure indicated in table. Valve must be mounted in horizontal pipe with solenoid enclosure vertical and on top.

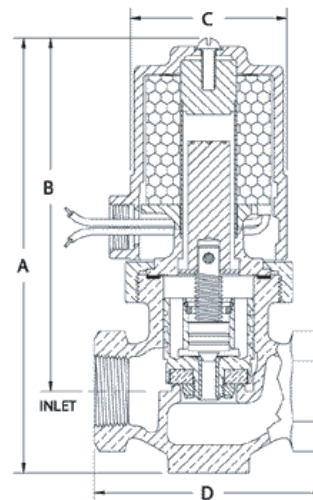

Pipe Size Inches	Max Diff. PSI	Type No.	Watts AC	Amps Hold 120-60	Amps Inrush 120-60	Watts DC	Ship Wt. Lbs.	Dimension In Inches				D(Flanged) 150#
								A	B	C	D	
1/2	110	18A42	25	0.4	1.2	18	8	7	5-7/8	2-3/4	3-1/4	4-3/4
	200	18A32										N/A
	300	18A52										
3/4	50	E33A62	45	0.8	2.4	23	16	8	6-7/8	4-1/8	3-1/4	N/A
	110	18A23	25	0.4	1.3	18	8	7-1/8	6	2-3/4	3-1/2	
	160	18A43	40	0.6	2.0	28						
	200	33A33	45	0.8	2.6	23	12	8-1/8	7	3-1/2	3-1/2	N/A
	300	33A53	45	0.8	2.6	23	12	8-1/8	7	3-1/2	3-1/2	
	500	E133A63	65	1.2	3.9	33	17	8-1/8	7	4-1/8	3-1/2	
1	50	18A24	25	0.4	1.5	18	10	7-7/8	6-5/8	2-3/4	4-1/8	5
	110	18A44	40	0.6	2.3	28						
	160	118A43	40	0.6	2.0	28	14	8-7/8	7-1/2	4-1/8	4-1/8	
	200	33A34	45	0.8	2.8	23						
	300	33A54	45	0.8	2.8	23						
500	E133A64	65	1.2	4.2	33	19	8-7/8	7-1/2	4-1/8	4-1/8	N/A	
1-1/4	50	18A25	25	0.4	1.6	18	12	8-3/8	6-3/4	2-3/4	4-1/2	7
	90	18A45	40	0.6	2.4	28						
	150	118A45	40	0.6	2.4	28	16	9-3/8	7-3/4	3-1/2	4-1/2	
	200	33A35	45	0.8	3.0	23						
	300	33A55	45	0.8	3.0	23						
500	40A65	60	1.2	6.2	N/A	20	10-3/8	8-3/4	4-1/2	4-1/2	N/A	
1-1/2	50	35A26	45	0.8	3.2	23	20	10	8-1/8	4	4-7/8	7-3/4
	115	35A46	45	0.8	3.2	23						
	160	135A46	65	1.2	4.8	33	24	11	9-1/8	4-1/2	4-7/8	
	200	41A36	60	1.2	6.7	35						
300	41A56	60	1.2	6.7	35	31	11	8-3/4	5-3/8	6		
500	141A66	85	2.0	10.0	45							
2	50	36A27	45	0.8	3.5	23	31	11	8-3/4	5-3/8	6	8
	100	36A47	45	0.8	3.5	23						
	150	136A47	65	1.2	5.0	33	36	12	9-3/4	5-3/4	6	
	200	42A37	60	1.2	7.4	35						
	300	42A57	60	1.2	7.4	35						
500	142A67	85	2.0	11.0	45	43	12-7/8	10-1/8	5-7/8	7-1/4		
2-1/2	50	43A28	60	1.2	8.0						35	
3	125	43A48	60	1.2	8.0	35	56	13-3/4	10-1/2	6-5/8	8-3/8	9-1/2
	200	43A38	60	1.2	8.0	35						
	300	143A58	85	2.0	12.0	45	N/A					
	500	144A59	85	2.0	13.0	45						

FOR OPTIONS & ACCESSORIES
SEE PAGES 26 & 27

Strainers are recommended for use with solenoid valves (See page 19)

When you order please supply the following:

- Pipe Size
- Valve Type
- Voltage (AC or DC)
- Hertz
- Fluid
- Fluid Temperature
- Max. Diff. Pressure
- Optional Features

(See pages 26 & 27)

†† Not available for DC operation

BRONZE SOLENOID VALVES

Dependable • Packless



TYPE "AR" FULL PORT - NORMALLY OPEN 1/2" TO 3" PIPE SIZE

NO DIFFERENTIAL PRESSURE REQUIRED TO OPEN

OPERATION:

Valve closes when energized and opens when de-energized. When the coil is energized the plunger presses the poppet, closing the pilot orifice, and opens a bleed passageway to permit pressure to build above the piston and seat it. Upon de-energizing the coil, the pilot orifice is opened, relieving the pressure above the piston allowing it to leave its seat. The bottom spring allows the valve to operate at zero pressure drop.

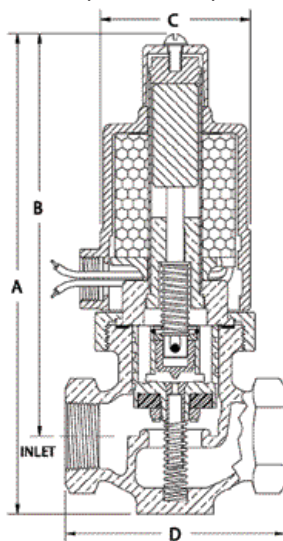

CONSTRUCTION: (* Wetted parts)

- *Valve Body - Cast Bronze, Globe Pattern - NPT ends
- *Piston - Bronze
- Coil Enclosure - Malleable or Cast Iron, 1/2" NPS conduit conn.
- *Plunger - 430 Stainless Steel
- *Pilot Valve - 303 Stainless Steel
- *Bonnet Tube - 304 Stainless Steel
- *Spring - 302 Stainless Steel
- *Body Seal - Buna N or Non Asbestos Gasket
- *Orifice Seal - Buna N (Viton or Glass Filled Teflon available)
- *AC Shading Coil - Copper
- *Stem Pin - Inconel
- Coil - Encapsulated Class B, 18" leads - (Class H available)

APPLICATION:

To control the flow of Water, Oil, Air, Gas, Solvents, Brine, Vacuum and any other fluids not reactive with construction materials and free of sediment. Valve operates from zero to maximum differential pressure indicated in table. Valve must be mounted in horizontal pipe with solenoid enclosure vertical and on top.



MAX. FLUID TEMP.
212° F

MAX. STATIC PRESSURE
300 PSI

Except valves listed for 500 PSI

**FOR OPTIONS & ACCESSORIES
SEE PAGES 26 & 27**

Strainers are recommended for use with solenoid valves (See page 19)

When you order please supply the following:

- Pipe Size
- Valve Type
- Voltage (AC or DC)
- Hertz
- Fluid
- Fluid Temperature
- Max. Diff. Pressure
- Optional Features

(See pages 26 & 27)

†† Not available for DC operation

Pipe Size Inches	Max Diff. PSI	Type No.	Watts AC	Amps Hold 120-60	Amps Inrush 120-60	Watts DC	Ship Wt. Lbs.	Dimension In Inches				
								A	B	C	D	D(Flanged) 150#
1/2	110	18AR42	25	0.5	1.5	18	8	8-1/8	7	2-3/4	3-1/4	4-3/4
	200	18AR32										N/A
300	18AR52	N/A										
3/4	50	18AR23	25	0.5	1.6	18	9	8-1/4	7-1/8	2-3/4	3-1/2	5-1/2
	110	18AR43										N/A
	200	33AR33	45	1.0	2.9	23	13	9-1/4	8-1/8	3-1/2	3-1/2	5-1/2
	300	33AR53										N/A
1	50	18AR24	25	0.5	1.8	18	11	9	7-3/4	2-3/4	4-1/8	5
	110	18AR44										N/A
	200	33AR34	45	1.0	3.0	23	14	10	8-5/8	3-1/2	4-1/8	5
300	33AR54	N/A										
1-1/4	50	18AR25	25	0.5	1.9	18	13	9-3/4	8-1/8	2-3/4	4-1/2	7
	90	18AR45										N/A
	200	33AR35	45	1.0	3.2	23	17	10-3/4	9-1/8	3-1/2	4-1/2	7
300	33AR55	N/A										
1-1/2	50	35AR26	45	1.0	3.8	23	21	11-3/8	9-1/2	4	4-7/8	7-3/4
	115	35AR46										N/A
	200	41AR36	60	1.7	6.5	35	25	11-5/8	9-3/4	4-1/2	4-7/8	7-3/4
300	41AR56	N/A										
2	50	36AR27	45	1.0	4.2	23	31	12-3/8	10-1/8	5-3/8	6	8
	100	36AR47										N/A
	200	42AR37	60	1.7	7.3	35	36	12-5/8	10-3/8	5-3/4	6	8
300	42AR57	N/A										
2-1/2	50	43AR28	60	1.7	8.0	35	45	13-1-2	10-3-4	5-7/8	7-1/4	11
	125	43AR48										N/A
	200	43AR38	85	3.5	13.0	45	45	13-1-2	10-3-4	5-7/8	7-1/4	11
300	143AR58	N/A										
3	50	44AR29	60	1.7	8.8	35	57	14-3/8	11-1/8	6-5/8	8-3/8	9-1/2
	100	44AR49										N/A
	200	44AR39	85	3.5	13.0	45	45	14-3/8	11-1/8	6-5/8	8-3/8	9-1/2
	300	144AR59										N/A

MAGNATROL VALVE CORPORATION



BRONZE SOLENOID VALVES

Dependable • Packless

TYPE "M" - NORMALLY CLOSED 3/8" TO 3/4" PIPE SIZE

NO DIFFERENTIAL PRESSURE REQUIRED TO OPEN

DIRECT ACTING - ORIFICE SIZES 1/8" TO 1/2"

OPERATION:

Valve opens when energized and closes when de-energized. In this direct acting valve, when the coil is energized, the stem is lifted from its conical seat by the plunger.

CONSTRUCTION: (* Wetted parts)

- *Valve Body - Cast Bronze, Globe Pattern - NPT ends
- Coil Enclosure - Malleable Iron, 1/2" NPS conduit conn.
- *Plunger - 430 Stainless Steel
- *Valve Stem - 303 Stainless Steel
- *Bonnet Tube - 304 Stainless Steel
- *Spring - Inconel
- *Body Seal - Non Asbestos Gasket
- *Orifice Seal - Metal to Metal
- *AC Shading Coil - Copper
- *Stem Pin - Inconel
- Coil - Encapsulated Class H, 18" leads

APPLICATION:

To control the flow of **Steam, Hot Liquids, Hot Gases, Cryogenics**** and any other fluids not reactive with construction materials and free of sediment. Cryogenic fluids include Liquid Oxygen (-297°F), Liquid Argon (-303°F) and Liquid Nitrogen (-320°F). Valve operates from zero to maximum differential pressure indicated in table. Valve must be mounted in horizontal pipe with solenoid enclosure vertical and on top.

****Cleaning:**

- Cryogenic valves are degreased and cleaned to keep them free of moisture.
- Oxygen valves are also "black light" tested.

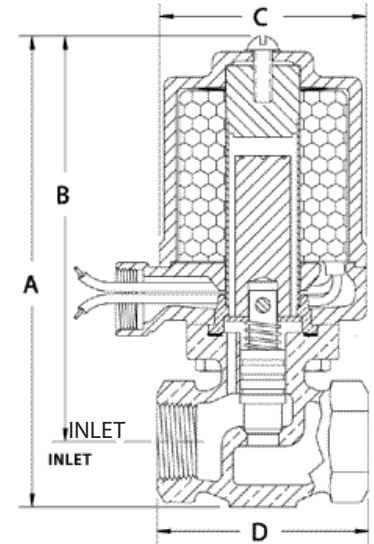

MAX. FLUID TEMP.
400° F
MAX. STATIC PRESSURE
150 PSI



FOR OPTIONS & ACCESSORIES
SEE PAGES 26 & 27

Pipe Size Inches	Max. Diff. PSI	Valve Port Size	Type No.	Watts AC	Amps Hold 120-60	Amps Inrush 120-60	Watts DC	Ship Wt. Lbs.	Dimensions In Inches											
									A	B	C	D								
3/8	25	3/8	10M21	25	0.4	1.1	18	6	6-1/4	5-1/2	2-7/8	2-5/8								
	50	1/4	10M41																	
	75	3/16	10M51																	
	100	5/32	10M81																	
	150	1/8	10M61																	
	50	3/8	25M21										45	0.8	2.3	23	10	7-1/8	6-3/8	3-1/2
75	5/16	25M31																		
100	1/4	25M41																		
150	3/16	25M51																		
25	3/8	10M22	25	0.4	1.2	18	6	6-1/4	5-1/2	2-7/8	2-3/4									
50	1/4	10M42																		
75	3/16	10M52																		
100	5/32	10M82																		
150	1/8	10M62																		
50	3/8	25M22										45	0.8	2.4	23	10	7-1/8	6-3/8	3-1/2	2-3/4
75	5/16	25M32																		
100	1/4	25M42																		
150	3/16	25M52																		
15	1/2	10M13	25	0.4	1.3	18	7	6-1/2	5-5/8	2-7/8	2-7/8									
35	5/16	10M33																		
30	1/2	25M13										45	0.8	2.5	23	10	7-3/8	6-1/2	3-1/2	2-7/8
75	5/16	25M33																		

Optional "Soft Seat" Orifice Seal (for applications requiring tight seating)

Viton - Suitable for Fuel Oils, Gaseous Oxygen and other compatible fluids

Strainers are recommended for use with solenoid valves (See page 19)

When you order please supply the following:

- Pipe Size
 - Valve Type
 - Voltage (AC or DC)
 - Hertz
 - Fluid
 - Fluid Temperature
 - Max. Diff. Pressure
 - Optional Features
- (See pages 26 & 27)

BRONZE SOLENOID VALVES

Dependable • Packless



TYPE "MR" - NORMALLY OPEN

3/8" TO 3/4" PIPE SIZE

NO DIFFERENTIAL PRESSURE REQUIRED TO OPEN

DIRECT ACTING - ORIFICE SIZES 1/8" TO 1/2"

OPERATION:

Valve closes when energized and opens when de-energized. In this direct acting valve, when the coil is energized, the stem is pressed into its conical seat by the plunger.

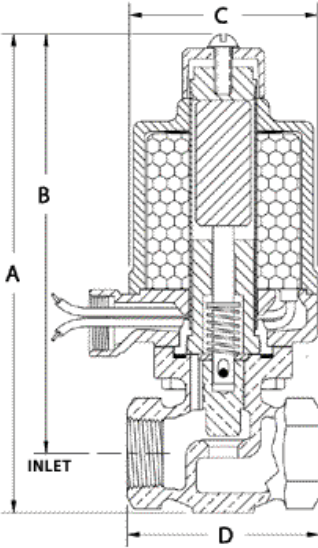

CONSTRUCTION: (* Wetted parts)

- *Valve Body - Cast Bronze, Globe Pattern - NPT ends
- Coil Enclosure - Malleable Iron, 1/2" NPS conduit conn.
- *Plunger - 430 Stainless Steel
- *Poppet - 304 Stainless Steel
- *Stem - 303 Stainless Steel
- *Bonnet Tube - 304 Stainless Steel
- *Spring - Inconel
- *Body Seal - Non Asbestos Gasket
- *Orifice Seal - Metal to Metal
- *AC Shading Coil - Copper
- *Stem Pin - Inconel
- Coil - Encapsulated Class H, 18" leads



APPLICATION:

To control the flow of Steam, Hot Liquids, Hot Gases, Cryogenics** and any other fluids not reactive with construction materials and free of sediment. Cryogenic fluids include Liquid Oxygen (-297°F), Liquid Argon (-303°F) and Liquid Nitrogen (-320°F). Valve operates from zero to maximum differential pressure indicated in table. Valve must be mounted in horizontal pipe with solenoid enclosure vertical and on top.



**FOR OPTIONS & ACCESSORIES
SEE PAGES 26 & 27**

****Cleaning:**

- Cryogenic valves are degreased and cleaned to keep them free of moisture.
- Oxygen valves are also "black light" tested.

Strainers are recommended for use with solenoid valves

(See page 19)

When you order please supply the following:

- Pipe Size
- Valve Type
- Voltage (AC or DC)
- Hertz
- Fluid
- Fluid Temperature
- Max. Diff. Pressure
- Optional Features

(See pages 26 & 27)

Pipe Size Inches	Max. Diff. PSI	Valve Port Size	Type No.	Watts AC	Amps Hold 120-60	Amps Inrush 120-60	Watts DC	Ship Wt. Lbs.	Dimensions In Inches											
									A	B	C	D								
3/8	23	3/8	† 10MR21	25	0.5	1.4	18	7	7	6-1/4	2-7/8	2-5/8								
	45	1/4	† 10MR41																	
	70	3/16	† 10MR51																	
	90	5/32	† 10MR81																	
	135	1/8	† 10MR61																	
	45	3/8	25MR21																	
70	5/16	25MR31	45	1.0	2.6	23	10	7-7/8	7-1/8	3-1/2	2-5/8									
90	1/4	25MR41																		
135	3/16	25MR51																		
23	3/8	10MR22										25	0.5	1.5	18	7	7	6-1/4	2-7/8	2-3/4
45	1/4	10MR42																		
70	3/16	10MR52																		
90	5/32	10MR82																		
135	1/8	10MR62																		
45	3/8	25MR22																		
70	5/16	25MR32	45	1.0	2.7	23	10	7-7/8	7-1/8	3-1/2	2-3/4									
90	1/4	25MR42																		
135	3/16	25MR52																		
13	1/2	10MR13										25	0.5	1.6	18	7	7-1/4	6-3/8	2-7/8	2-7/8
32	5/16	10MR33																		
27	1/2	25MR13																		
70	5/16	25MR33																		

Optional "Soft Seat" Orifice Seal (for applications requiring tight seating)

Viton - Suitable for Fuel Oils, Gaseous Oxygen and other compatible fluids

† UL Listed Valves - Consult Factory

MAGNATROL VALVE CORPORATION



BRONZE SOLENOID VALVES

Dependable • Packless

TYPE "S" FULL PORT - NORMALLY CLOSED 1/2" TO 3" PIPE SIZE

NO DIFFERENTIAL PRESSURE REQUIRED TO OPEN

MAX. FLUID TEMP.
400° F
MAX. STATIC PRESSURE
200 PSI



OPERATION:

Valve opens when energized and closes when de-energized. When the coil is energized the pilot valve opens, relieving the pressure above the piston, which is then lifted from its seat by the plunger. Upon de-energizing the coil, a spring closes the pilot valve and opens a bleed passageway to permit pressure to build above the piston and seat it.

CONSTRUCTION: (* Wetted parts)

- *Valve Body - Cast Bronze, Globe Pattern - NPT ends
- *Piston - Bronze
- Coil Enclosure - Malleable or Cast Iron, 1/2" NPS conduit conn.
- *Plunger - 430 Stainless Steel
- *Pilot Valve - 303 Stainless Steel
- *Bonnet Tube - 304 Stainless Steel
- *Spring - Inconel
- *Body Seal - Non Asbestos Gasket
- *Orifice Seal - Glass Filled Teflon
- *AC Shading Coil - Copper
- *Stem Pin - Inconel
- Coil - Encapsulated Class H, 18" leads

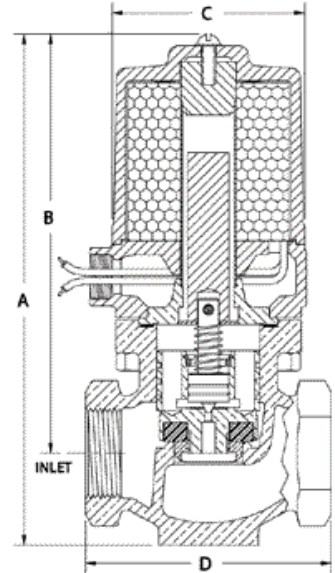

APPLICATION:

TO CONTROL THE FLOW OF STEAM. Steam must be free of sediment. Valve operates from zero to maximum differential pressure indicated in table. Valve must be mounted in horizontal pipe with solenoid enclosure vertical and on top.

FOR OPTIONS & ACCESSORIES
SEE PAGES 26 & 27

Pipe Size Inches	Max Diff. PSI	Type No.	Watts AC	Amps Hold 120-60	Amps Inrush 120-60	Watts DC	Ship Wt. Lbs.	Dimension In Inches										
								A	B	C	D	D(Flanged) 150#						
1/2	90	† 14S22	25	0.4	1.2	18	8	7	5-7/8	2-7/8	3-1/4	4-3/4						
	140	†114S42	40	0.6	1.8	28		8	6-7/8	3-1/2	3-1/4	N/A						
	180	129S42	65	1.2	3.6	33		11	8-1/8	7	3-1/2	3-1/2	N/A					
3/4	50	† 14S23	25	0.4	1.3	18	9	7-1/8	6	2-7/8	3-1/2	5-1/2						
	110	†114S43	40	0.6	2.0	28		8-1/8	7	3-1/2	3-1/2	N/A						
	180	129S43	65	1.2	3.9	33		12	8-1/8	7	3-1/2	3-1/2	N/A					
1	25	† 16S14	25	0.4	1.5	18	11	8	6-5/8	3-1/4	4-1/2	5						
	50	†116S24	40	0.6	2.3	28		14	8-7/8	7-1/2	3-1/2	4-1/8	N/A					
	90	†116S44																
180	131S44	65	1.2	4.2	33													
1-1/4	25	† 17S15	25	0.4	1.6	18	12	8-3/8	6-3/4	3-1/2	4-1/2	7						
	50	†117S25	40	0.6	2.4	28												
	140	132S45	65	1.2	4.8	33												
	180	††140S45	85	2.0	9.2	N/A							20	10-3/8	8-3/4	4-1/2	4-1/2	N/A
1-1/2	25	35S16	45	0.8	3.2	23	20	10	8-1/8	4	4-7/8	7-3/4						
	50	35S26																
	90	135S46	65	1.2	4.8	33												
	180	141S46	85	2.0	11.0	45							24	11	9-1/8	4-1/2	4-7/8	N/A
2	25	36S17	45	0.8	3.5	23	31	11	8-3/4	5-3/8	6	8						
	50	36S27																
	115	42S47	60	1.2	7.4	35							36	12	9-3/4	5-3/8	6	N/A
	180	142S47	85	2.0	11.0	45												
2-1/2	25	43S18	60	1.2	8.0	35	43	12-7/8	10-1/8	5-7/8	7-1/4	11						
	50	43S28																
	115	43S48																
	175	143S48											85	2.0	12.0	45	N/A	
3	25	44S19	60	1.2	8.8	35	56	13-3/4	10-1/2	6-5/8	8-3/8	9-1/2						
	50	44S29																
	100	44S49																
	150	144S49											85	2.0	13.0	45		

Strainers are recommended for use with solenoid valves (See page 19)

When you order please supply the following:

- Pipe Size
 - Valve Type
 - Voltage (AC or DC)
 - Hertz
 - Fluid
 - Fluid Temperature
 - Max. Diff. Pressure
 - Optional Features
- (See pages 26 & 27)

† UL Listed Valves - Consult Factory †† Not available for DC operation

BRONZE SOLENOID VALVES

Dependable • Packless



TYPE "SR" FULL PORT - NORMALLY OPEN 1/2" TO 3" PIPE SIZE

NO DIFFERENTIAL PRESSURE REQUIRED TO OPEN

OPERATION:

Valve closes when energized and opens when de-energized. When the coil is energized the plunger presses the poppet, closing the pilot orifice, and opens a bleed passageway to permit pressure to build above the piston and seat it. Upon de-energizing the coil, the pilot orifice is opened, relieving the pressure above the piston allowing it to leave its seat. The bottom spring allows the valve to operate at zero pressure drop.

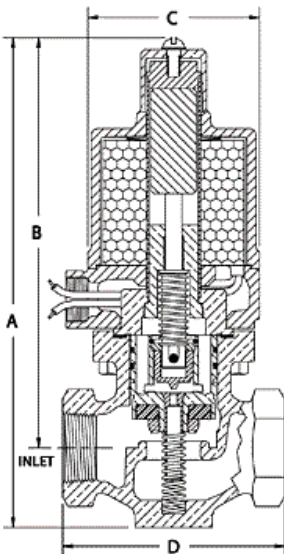

CONSTRUCTION: (* Wetted parts)

- *Valve Body - Cast Bronze, Globe Pattern - NPT ends
- *Piston - Bronze
- Coil Enclosure - Malleable or Cast Iron, 1/2" NPS conduit conn.
- *Plunger - 430 Stainless Steel
- *Poppet - 303 Stainless Steel
- *Stem - 303 Stainless Steel
- *Bonnet Tube - 304 Stainless Steel
- *Springs - Inconel and 302 Stainless Steel
- *Body Seal - Non Asbestos Gasket
- *Orifice Seal - Glass Filled Teflon
- *AC Shading Coil - Copper
- *Stem Pin - 304 Stainless Steel
- Coil - Encapsulated Class H, 18" leads



APPLICATION:

TO CONTROL THE FLOW OF STEAM. Steam must be free of sediment. Valve operates from zero to maximum differential pressure indicated in table. Valve must be mounted in horizontal pipe with solenoid enclosure vertical and on top.

MAX. FLUID TEMP.
400° F
MAX. STATIC PRESSURE
200 PSI



**FOR OPTIONS & ACCESSORIES
SEE PAGES 26 & 27**

Strainers are recommended for use with solenoid valves (See page 19)

When you order please supply the following:

- Pipe Size
- Valve Type
- Voltage (AC or DC)
- Hertz
- Fluid
- Fluid Temperature
- Max. Diff. Pressure
- Optional Features

(See pages 26 & 27)

Pipe Size Inches	Max Diff. PSI	Type No.	Watts AC	Amps Hold 120-60	Amps Inrush 120-60	Watts DC	Ship Wt. Lbs.	Dimension In Inches					
								A	B	C	D	D(Flanged) 150#	
1/2	90	† 14SR22	25	0.5	1.5	18	8	8-1/8	7	2-7/8	3-1/4	4-3/4	
	140	† 114SR42	40	0.8	2.4	28		9-1/8	8	3-1/2	3-1/4	N/A	
	180	129SR42	65	1.5	4.2	33		11	9-1/8	8	3-1/2	3-1/4	N/A
3/4	50	† 14SR23	25	0.5	1.6	18	9	7-1/8	6	2-7/8	3-1/2	5-1/2	
	110	† 114SR43	40	0.8	2.6	28		13	9-1/4	8-1/8	3-1/2	3-1/2	N/A
	180	129SR43	65	1.5	4.3	33			9-1/4	8-1/8	3-1/2	3-1/2	N/A
1	25	† 16SR14	25	0.5	1.8	18	11	9-1/8	7-3/4	3-1/4	4-1/8	5	
	50	† 116SR24	40	0.8	2.9	28		15	10	8-5/8	3-1/2	4-1/8	N/A
	180	131SR44	65	1.5	4.5	33			10	8-5/8	3-1/2	4-1/8	N/A
1-1/4	25	† 17SR15	25	0.5	1.9	18	13	9-3/4	8-1/8	3-1/2	4-1/2	7	
	50	† 117SR25	40	0.8	3.0	28		10-3/4	9-1/8	3-5/8	4-1/2		
	140	132SR45	65	1.5	4.8	33		17	10-3/4	9-1/8	3-5/8	4-1/2	N/A
1-1/2	25	35SR16	45	1.0	3.8	23	21	11-3/8	9-1/2	4	4-7/8	7-3/4	
	50	35SR26	60	1.5	5.7	33		25	11-5/8	9-3/4	4-1/2	4-7/8	N/A
	140	135SR46	60	1.5	5.7	33			11-5/8	9-3/4	4-1/2	4-7/8	N/A
2	25	36SR17	45	1.0	4.2	23	31	12-3/8	10-1/8	5-3/8	6	8	
	50	36SR27	60	1.7	7.3	35		36	12-5/8	10-3/8	5-3/8		6
	115	42SR47	60	1.7	7.3	35			36	12-5/8	10-3/8	5-3/8	6
2-1/2	25	43SR18	60	1.7	8.0	35	45	13-1/2	10-3/4	5-7/8	7-1/4	11	
	50	43SR28	60	1.7	8.0	35		57	14-3/8	11-1/8	6-5/8		8-3/8
	115	43SR48	85	3.5	12.0	45			14-3/8	11-1/8	6-5/8	8-3/8	9-1/2
3	25	44SR19	60	1.7	8.8	35	57	14-3/8	11-1/8	6-5/8	8-3/8	9-1/2	
	50	44SR29	60	1.7	8.8	35		57	14-3/8	11-1/8	6-5/8		8-3/8
	100	44SR49	85	3.5	13.0	45			14-3/8	11-1/8	6-5/8	8-3/8	9-1/2

† UL Listed Valves - Consult Factory †† Not available for DC operation

MAGNATROL VALVE CORPORATION



BRONZE SOLENOID VALVES

Dependable • Packless

TYPE "L" FULL PORT - NORMALLY CLOSED 1/2" TO 3" PIPE SIZE

NO DIFFERENTIAL PRESSURE REQUIRED TO OPEN

MAX. FLUID TEMP.
400° F

MAX. STATIC PRESSURE
300 PSI

Except valves listed for 500 PSI



OPERATION:

Valve opens when energized and closes when de-energized. When the coil is energized the pilot valve opens, relieving the pressure above the piston, which is then lifted from its seat by the plunger. Upon de-energizing the coil, a spring closes the pilot valve and opens a bleed passageway to permit pressure to build above the piston and seat it.

CONSTRUCTION: (* Wetted parts)

- *Valve Body - Cast Bronze, Globe Pattern - NPT ends
- *Piston - Bronze
- Coil Enclosure - Malleable or Cast Iron, 1/2" NPT conduit conn.
- *Plunger - 430 Stainless Steel
- *Pilot Valve - 303 Stainless Steel
- *Bonnet Tube - 304 Stainless Steel
- *Spring - Inconel
- *Body Seal - Non Asbestos Gasket
- *Orifice Seal - Glass Filled Teflon
- *AC Shading Coil - Copper
- *Stem Pin - Inconel
- Coil - Encapsulated Class H, 18" leads

**FOR OPTIONS & ACCESSORIES
SEE PAGES 26 & 27**

**FOR STEAM APPLICATIONS
SEE BULLETIN 3006-S
Page 12**

APPLICATION:

To control the flow of Hot Liquids, Hot Gases, Cryogenics** and any other fluids not reactive with construction materials and free of sediment. Cryogenic fluids include Liquid Oxygen (-297°F), Liquid Argon (-303°F) and Liquid Nitrogen (-320°F). Valve operates from zero to maximum differential pressure indicated in table. Valve must be mounted in horizontal pipe with solenoid enclosure vertical and on top.

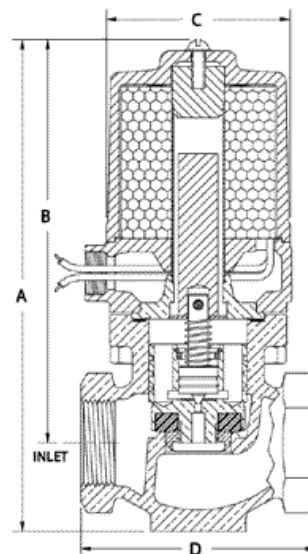

Pipe Size Inches	Max Diff. PSI	Type No.	Watts AC	Amps Hold 120-60	Amps Inrush 120-60	Watts DC	Ship Wt. Lbs.	Dimension In Inches				
								A	B	C	D	D(Flanged) 150#
1/2	110	14L42	25	0.4	1.2	18	8	7	5-7/8	2-7/8	3-1/4	4-3/4
	200	14L32										4-3/4
	300	29L52	45	0.8	2.4	23	11	8	6-7/8	3-1/2	3-1/4	N/A
3/4	50	14L23	25	0.4	1.3	18	9	7-1/8	6	2-7/8	3-1/2	5-1/2
	110	14L43										5-1/2
	200	29L33	45	0.8	2.6	23	12	8-1/8	7	3-1/2	3-1/2	N/A
	300	129L53	65	1.2	3.9	33	17	8-1/8	7	4	3-1/2	N/A
	500	E129L63	65	1.2	3.9	33	17	8-1/8	7	4	3-1/2	N/A
1	50	16L24	25	0.4	1.5	18	11	8	6-5/8	3-1/4	4-1/8	5
	110	16L44										5
	200	31L34	45	0.8	2.8	23	14	8-7/8	7-1/2	3-1/2	4-1/8	N/A
	300	131L54	65	1.2	4.2	33	19	8-7/8	7-1/2	4	4-1/8	N/A
	500	E131L64	65	1.2	4.2	33	19	8-7/8	7-1/2	4	4-1/8	N/A
1-1/4	50	17L25	25	0.4	1.6	18	12	8-3/8	6-3/4	3-1/2	4-1/2	7
	90	17L45										7
	200	32L35	45	0.8	3.0	23	16	9-3/8	7-3/4	3-5/8	4-1/2	N/A
	300	132L55	65	1.2	4.5	33	20	10-3/8	8-3/4	4-1/2	4-1/2	N/A
	500	†† 140L65	85	2.0	9.2	N/A	20	10-3/8	8-3/4	4-1/2	4-1/2	N/A
1-1/2	50	35L26	45	0.8	3.2	23	20	10	8-1/8	4	4-7/8	7-3/4
	115	35L46										7-3/4
	200	41L36	60	1.2	6.7	35	24	11	9-1/8	4-1/2	4-7/8	N/A
	300	141L56	85	2.0	10.0	45	24	11	9-1/8	4-1/2	4-7/8	N/A
2	50	36L27	45	0.8	3.5	23	31	11	8-3/4	5-3/8	6	8
	100	36L47										8
	200	42L37	60	1.2	7.4	35	36	12	9-3/4	5-3/8	6	N/A
	300	42L57	60	1.2	7.4	35	36	12	9-3/4	5-3/8	6	N/A
2-1/2	50	43L28	60	1.2	8.0	35	43	12-7/8	10-1/8	5-7/8	7-1/4	11
	125	43L48										11
	200	43L38	60	1.2	8.0	35	43	12-7/8	10-1/8	5-7/8	7-1/4	N/A
	300	143L58	85	2.0	12.0	45	43	12-7/8	10-1/8	5-7/8	7-1/4	N/A
3	50	44L29	60	1.2	8.8	35	56	13-3/4	10-1/2	6-5/8	8-3/8	9-1/2
	100	44L49										9-1/2
	200	44L39	60	1.2	8.8	35	56	13-3/4	10-1/2	6-5/8	8-3/8	N/A
	300	144L59	85	2.0	13.0	45	56	13-3/4	10-1/2	6-5/8	8-3/8	N/A

†† Not available for DC operation

**** CLEANING**

- Cryogenic valves are degreased & cleaned to keep them free of moisture.
- Oxygen valves are also "black light" tested.

Strainers are recommended for use with solenoid valves

(See page 19)

When you order please supply the following:

- Pipe Size
- Valve Type
- Voltage (AC or DC)
- Hertz
- Fluid
- Fluid Temperature
- Max. Diff. Pressure
- Optional Features

(See pages 26 & 27)

BRONZE SOLENOID VALVES

Dependable • Packless



TYPE "LR" FULL PORT - NORMALLY OPEN 1/2" TO 3" PIPE SIZE

NO DIFFERENTIAL PRESSURE REQUIRED TO OPEN

OPERATION:

Valve closes when energized and opens when de-energized. When the coil is energized the plunger presses the poppet, closing the pilot orifice, and opens a bleed passageway to permit pressure to build above the piston and seal it. Upon de-energizing the coil, the pilot orifice is opened, relieving the pressure above the piston allowing it to leave its seat. The bottom spring allows the valve to operate at zero pressure drop.

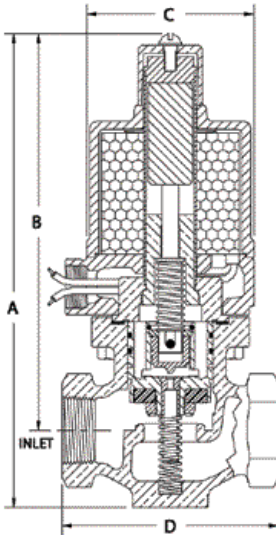

CONSTRUCTION: (* Wetted parts)

- *Valve Body - Cast Bronze, Globe Pattern - NPT ends
- *Piston - Bronze
- Coil Enclosure - Malleable or Cast Iron, 1/2" NPT conduit conn.
- *Plunger - 430 Stainless Steel
- *Poppet - 303 Stainless Steel
- *Stem - 303 Stainless Steel
- *Bonnet Tube - 304 Stainless Steel
- *Springs - Inconel and 302 Stainless Steel
- *Body Seal - Non Asbestos Gasket
- *Orifice Seal - Glass Filled Teflon
- *AC Shading Coil - Copper
- *Stem Pin - 304 Stainless Steel
- Coil - Encapsulated Class H, 18" leads

**FOR OPTIONS & ACCESSORIES
SEE PAGES 26 & 27**

**FOR STEAM APPLICATIONS
SEE BULLETIN 3006-SR
Page 13**

**MAX. FLUID TEMP.
400° F**
**MAX. STATIC PRESSURE
300 PSI**
Except valves listed for 500 PSI



APPLICATION:

To control the flow of Hot Liquids, Hot Gases, Cryogenics** and any other fluids not reactive with construction materials and free of sediment. Cryogenic fluids include Liquid Oxygen (-297°F), Liquid Argon (-303°F) and Liquid Nitrogen (-320°F). Valve operates from zero to maximum differential pressure indicated in table. Valve must be mounted in horizontal pipe with solenoid enclosure vertical and on top.

** CLEANING

- Cryogenic valves are degreased & cleaned to keep them free of moisture.
- Oxygen valves are also "black light" tested.

Strainers are recommended for use with solenoid valves

(See page 19)

When you order please supply the following:

- Pipe Size
- Valve Type
- Voltage (AC or DC)
- Hertz
- Fluid
- Fluid Temperature
- Max. Diff. Pressure
- Optional Features

(See pages 26 & 27)

Pipe Size Inches	Max Diff. PSI	Type No.	Watts AC	Amps Hold 120-60	Amps Inrush 120-60	Watts DC	Ship Wt. Lbs.	Dimension In Inches														
								A	B	C	D	D(Flanged) 150#										
1/2	110	14LR42	25	0.5	1.5	18	18	8-1/8	7	2-7/8	3-1/4	4-3/4										
	200	14LR32						9-1/8	8	3-1/2	3-1/4											
	300	29LR52						45	1.0	2.7	23	11	9-1/8	8	3-1/2	3-1/4	N/A					
3/4	50	14LR23	25	0.5	1.6	18	9	8-1/4	7-1/8	2-7/8	3-1/2	5-1/2										
	110	14LR43																				
	200	29LR33											45	1.0	2.9	23	13	9-1/4	8-1/8	3-1/2	3-1/2	N/A
	300	129LR53											65	1.5	4.3	33	18	9-1/4	8-1/8	4	3-1/2	
	500	E129LR63											65	1.5	4.3	33	18	9-1/4	8-1/8	4	3-1/2	
1	50	16LR24	25	0.5	1.8	18	11	9-1/8	7-3/4	3-1/4	4-1/8	5										
	110	16LR44																				
	200	31LR34											45	1.0	3.0	23	15	10	8-5/8	3-1/2	4-1/8	N/A
	300	131LR54											65	1.5	4.5	33	20	10	8-5/8	4	4-1/8	
1-1/4	50	17LR25	25	0.5	1.9	18	13	9-3/4	8-1/8	3-1/2	4-1/2	7										
	90	17LR45																				
	200	32LR35											45	1.0	3.2	23	17	10-3/4	9-1/8	3-5/8	4-1/2	N/A
	300	132LR55											65	1.5	4.8	33	20	11	9-3/8	4-1/2	4-1/2	
	500	†† 140LR65											85	3.5	9.0	N/A	20	11	9-3/8	4-1/2	4-1/2	
1-1/2	50	35LR26	45	1.0	3.8	23	21	11-3/8	9-3/8	4	4-7/8	7-3/4										
	115	35LR46																				
	200	41LR36											60	1.7	6.5	35	25	11-5/8	9-3/4	4-1/2	4-7/8	N/A
2	300	141LR56	85	3.5	9.7	45	31	12-3/8	10-1/8	5-3/8	6	8										
	500	141LR66																				
	50	36LR27											45	1.0	4.2	23	36	12-5/8	10-3/8	5-3/8	6	N/A
	100	36LR47																				
	200	42LR37																				
300	42LR57	60	1.7	7.3	35	45	13-1/2	10-3/4	5-7/8	7-1/4	11											
500	142LR67	85	3.5	11.0	45	45	13-1/2	10-3/4	5-7/8	7-1/4	N/A											
2-1/2	50	43LR28	60	1.7	8.0	35	45	13-1/2	10-3/4	5-7/8	7-1/4	9-1/2										
	125	43LR48																				
	200	43LR38																				
	300	143LR58											85	3.5	12.0	45	57	14-3/8	11-1/8	6-5/8	8-3/8	N/A
3	50	44LR29	60	1.7	8.8	35	57	14-3/8	11-1/8	6-5/8	8-3/8	9-1/2										
	100	44LR49																				
	200	44LR39																				
300	144LR59	85	3.5	13.0	45	57	14-3/8	11-1/8	6-5/8	8-3/8	N/A											

†† Not available for DC operation

MAGNATROL VALVE CORPORATION



BRONZE SOLENOID VALVES

Dependable • Packless

MAX. FLUID TEMP.
212° F
MAX. STATIC PRESSURE
150 PSI

TYPE "G" FULL PORT - NORMALLY CLOSED 1" TO 3" PIPE SIZE

NO DIFFERENTIAL PRESSURE REQUIRED TO OPEN

OPERATION:

Valve opens when energized and closes when de-energized. When the coil is energized the pilot valve opens, relieving the pressure above the piston, which is then lifted from its seat by the plunger. Upon de-energizing the coil, a spring closes the pilot valve and opens a bleed passageway to permit pressure to build above the piston and seat it.

CONSTRUCTION: (* Wetted parts)

- *Valve Body - Cast Bronze, Globe Pattern - NPT ends
- *Piston - Bronze
- Coil Enclosure - Malleable or Cast Iron, 1/2" NPS conduit conn.
- *Plunger - 430 Stainless Steel
- *Pilot Valve Stem - 303 Stainless Steel
- *Pilot Valve Disc Holder - Brass
- *Pilot Valve Seal - Buna N (Viton available)
- *Bonnet Tube - 304 Stainless Steel
- *Spring - 302 Stainless Steel
- *Body Seal - Buna N or Non Asbestos Gasket
- *Orifice Seal - Buna N (Viton or Glass Filled Teflon available)
- *AC Shading Coil - Copper
- *Stem Pin - Inconel
- Coil - Encapsulated Class B, 18" leads - (Class H available)

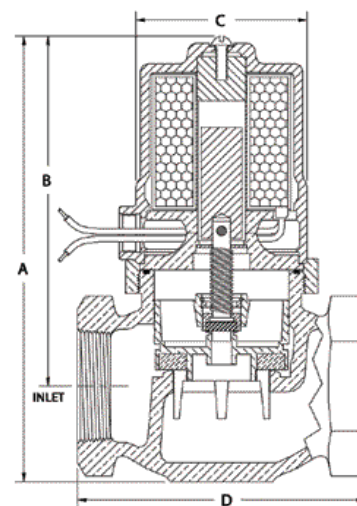

**FOR OPTIONS & ACCESSORIES
SEE PAGES 26 & 27**

APPLICATION:

To control the flow of Water, Air, Gas, Solvents, Vacuum and any other fluids not reactive with construction materials and free of sediment. Buna N seating of the pilot and main orifices make the valves ideal for **TIGHT SEATING, LOW PRESSURE** and **LOW FLOW** conditions. Valve operates from zero to maximum differential pressure indicated in table. Valve must be mounted in horizontal pipe with solenoid enclosure vertical and on top.

Strainers are recommended for use with solenoid valves
(See page 19)

Pipe Size Inches	Max Diff. PSI	Type No.	Watts AC	Amps Hold 120-60	Amps Inrush 120-60	Watts DC	Ship Wt. Lbs.	Dimension In Inches				
								A	B	C	D	D(Flanged) 150#
1	20	† 18G24	25	0.4	1.4	18	9	7-1/2	6-1/8	2-3/4	4-1/8	6-3/4
	30	118G24	40	0.6	2.3	28	9	7-1/2	6-1/8	2-3/4	4-1/8	
	50	133G24	65	1.2	4.0	33	13	8-1/2	7-1/8	3-1/2	4-1/8	
1-1/4	20	† 18G25	25	0.4	1.5	18	10	8	6-3/8	2-7/8	4-3/8	7
	30	118G25	40	0.6	2.4	28	10	8	6-3/8	2-7/8	4-3/8	
	50	133G25	65	1.2	4.1	33	14	8-7/8	7-3/8	3-1/2	4-3/8	
1-1/2	15	† 18G26	25	0.4	1.7	18	12	8-1/8	6-1/2	3-1/8	4-3/4	7-3/4
	25	118G26	40	0.6	2.5	28	12	8-1/8	6-1/2	3-1/8	4-3/4	
	35	133G26	65	1.2	4.2	33	16	9-1/8	7-1/2	3-1/2	4-3/4	
2	18	33G27	45	0.8	3.4	23	20	9-7/8	7-7/8	3-3/4	5-3/4	10
	30	133G27	65	1.2	4.2	33	20	9-7/8	7-7/8	3-3/4	5-3/4	
	50	233G27	80	1.8	9.0	40	20	9-7/8	7-7/8	3-3/4	5-3/4	
2-1/2	25	43G28	60	1.2	7.8	35	38	12-1/8	8-5/8	5-7/8	7-7/8	11
	35	143G28	85	2.0	12.0	45	38	12-1/8	9-5/8	5-7/8	7-7/8	
3	25	44G29	60	1.2	8.6	35	46	13	10	6-5/8	8	13-5/16
	35	144G29	85	2.0	13.0	45	46	13	10	6-5/8	8	

When you order please supply the following:

- Pipe Size
- Valve Type
- Voltage (AC or DC)
- Hertz
- Fluid
- Fluid Temperature
- Max. Diff. Pressure
- Optional Features

(See pages 26 & 27)

† UL Listed Valves - Consult Factory

BRONZE SOLENOID VALVES

Dependable • Packless



TYPE "GR" FULL PORT - NORMALLY OPEN 1" TO 3" PIPE SIZE

NO DIFFERENTIAL PRESSURE REQUIRED TO OPEN

OPERATION:

Valve closes when energized and opens when de-energized. When the coil is energized the plunger presses the poppet, closing the pilot orifice, and opens a bleed passageway to permit pressure to build above the piston and seat it. Upon de-energizing the coil, the pilot orifice is opened, relieving the pressure above the piston allowing it to leave its seat. The bottom spring allows the valve to operate at zero pressure drop.

MAX. FLUID TEMP.

212° F

MAX. STATIC PRESSURE

150 PSI

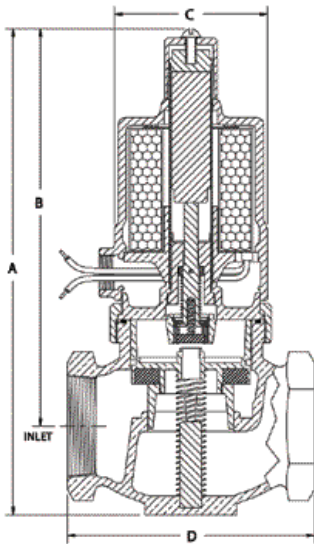

Strainers are recommended for use with solenoid valves

(See page 19)

CONSTRUCTION: (* Wetted parts)

- *Valve Body - Cast Bronze, Globe Pattern - NPT ends
- *Piston - Bronze
- Coil Enclosure - Malleable or Cast Iron, 1/2" NPS conduit conn.
- *Plunger - 430 Stainless Steel
- *Pilot Valve Stem - 303 Stainless Steel
- *Pilot Valve Disc Holder - Brass
- *Pilot Valve Seal - Buna N (Viton available)
- *Bonnet Tube - 304 Stainless Steel
- *Spring - 302 Stainless Steel
- *Body Seal - Buna N or Non Asbestos Gasket
- *Orifice Seal - Buna N (Viton or Glass Filled Teflon available)
- *AC Shading Coil - Copper
- *Stem Pin - Inconel



APPLICATION:

To control the flow of Water, Air, Gas, Solvents, Vacuum and any other fluids not reactive with construction materials and free of sediment. Buna N seating of the pilot and main orifices make the valves ideal for TIGHT SEATING, LOW PRESSURE and LOW FLOW conditions. Valve operates from zero to maximum differential pressure indicated in table. Valve must be mounted in horizontal pipe with solenoid enclosure vertical and on top.



**FOR OPTIONS & ACCESSORIES
SEE PAGES 26 & 27**

When you order please supply the following:

- Pipe Size
- Valve Type
- Voltage (AC or DC)
- Hertz
- Fluid
- Fluid Temperature
- Max. Diff. Pressure
- Optional Features

(See pages 26 & 27)

Pipe Size Inches	Max Diff. PSI	Type No.	Watts AC	Amps Hold 120-60	Amps Inrush 120-60	Watts DC	Ship Wt. Lbs.	Dimension In Inches				
								A	B	C	D	D(Flanged) 150#
1	20	† 18GR24	25	0.5	1.5	18	9	8-5/8	7-1/4	2-3/4	4-1/8	6-3/4
	35	33GR24	45	1.0	3.0	23	13	9-5/8	8-1/4	2-3/4	4-1/8	
1-1/4	20	† 18GR25	25	0.5	1.9	18	10	9-3/8	7-3/4	2-7/8	4-3/8	7
	35	33GR25	45	1.0	3.2	23	14	10-1/4	8-3/4	3-1/2	4-3/8	
1-1/2	15	† 18GR26	25	0.5	2.0	18	12	9-1/2	7-7/8	3-1/8	4-3/4	7-3/4
	25	33GR26	45	1.0	3.8	23	16	10-1/2	8-7/8	3-1/2	4-3/4	
2	18	33GR27	45	1.0	4.2	23	21	11-1/4	9-1/4	3-3/4	5-3/4	10
	30	133GR27	65	1.5	4.5	33	21	11-1/4	9-1/4	3-3/4	5-3/4	
2-1/2	25	43GR28	60	1.7	8.0	35	39	12-3/4	10-1/4	5-7/8	7-7/8	11
3	25	44GR29	60	1.7	8.8	35	47	13-5/8	10-5/8	6-5/8	8	13-5/16

† UL Listed Valves - Consult Factory

MAGNATROL VALVE CORPORATION



BRONZE SOLENOID VALVES

Dependable • Packless

TYPE "D" FULL PORT - NORMALLY CLOSED 3/8" TO 2" PIPE SIZE

NO DIFFERENTIAL PRESSURE REQUIRED TO OPEN

MAX. FLUID TEMP.
212° F
MAX. STATIC PRESSURE
150 PSI

OPERATION:

Valve opens when energized and closes when de-energized. In this direct acting valve the disc holder assembly is lifted from its seat by the plunger.

CONSTRUCTION: (* Wetted parts)

- *Valve Body - Cast Bronze, Globe Pattern - NPT ends
- *Disc Holder - Brass
- Coil Enclosure - Malleable or Cast Iron, 1/2" NPS conduit con
- *Plunger - 430 Stainless Steel
- *Stem - 303 Stainless Steel
- *Bonnet Tube - 304 Stainless Steel
- *Spring - 302 Stainless Steel
- *Body Seal - Buna N
- *Orifice Seal - Buna N (Viton or Glass Filled Teflon available)
- *AC Shading Coil - Copper
- *Stem Pin - Inconel
- Coil - Encapsulated Class B, 18" leads - (Class H available)

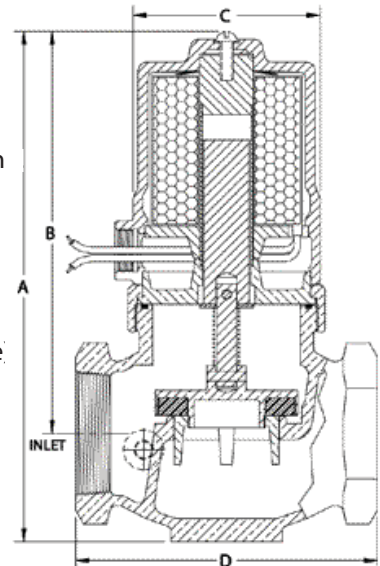
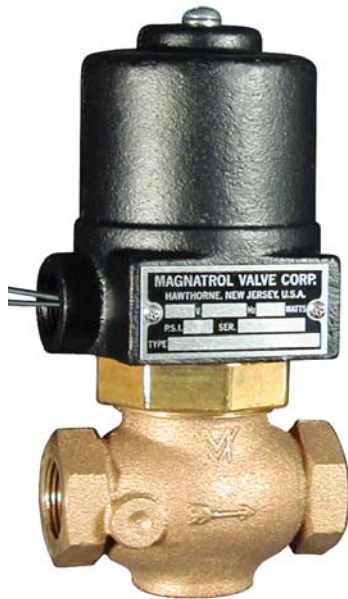

APPLICATION:

To control the flow of Water, Air, Gas, Solvents, Vacuum and any other fluids not reactive with construction materials and free of sediment. Buna N seating of the main orifice make the valves ideal for TIGHT SEATING, LOW PRESSURE and LOW FLOW conditions. Valve operates from zero to maximum differential pressure indicated in table. Valve must be mounted in horizontal pipe with solenoid enclosure vertical and on top.

Strainers are recommended for use with solenoid valves (See page 19)

FOR OPTIONS & ACCESSORIES
SEE PAGES 26 & 27



Pipe Size Inches	Max Diff. PSI	Type No.	Watts AC	Amps Hold 120-60	Amps Inrush 120-60	Watts DC	Ship Wt. Lbs.	Dimension In Inches					D(Flanged) 150#
								A	B	C	D		
3/8	15	18D11	25	0.4	1.0	18	7	6-1/4	5-3/8	2-3/4	2-7/8	N/A	
	30	33D11	45	0.8	2.3	23	10	7-1/8	6-3/8	3-1/2	2-7/8		
1/2	10	18D12	25	0.4	1.1	18	7	6-1/4	5-1/2	2-3/4	3-1/8	4-3/4	
	20	33D12	45	0.8	2.4	23	10	7-1/4	6-3/8	3-1/2	3-1/8		
3/4	4	18D13	25	0.4	1.2	18	8	6-7/8	5-3/4	2-3/4	3-1/2	5-1/2	
	7.5	33D13	45	0.8	2.5	23	12	7-3/4	6-3/4	3-1/2	3-1/2		
1	2	18D14	25	0.4	1.4	23	9	7-1/2	6-1/8	2-3/4	4-1/8	6-3/4	
	3.5	33D14	45	0.8	2.7	33	13	8-1/2	7-1/8	3-1/2	4-1/8		
1-1/4	1.3	18D15	25	0.4	1.5	18	10	8	6-3/8	2-7/8	4-3/8	7	
	2.3	33D15	45	0.8	2.8	23	14	8-7/8	7-3/8	3-1/2	4-3/8		
1-1/2	0.8	18D16	25	0.4	1.7	18	12	8-1/8	6-1/2	3-1/8	4-3/4	7-3/4	
	1.5	† 33D16	45	0.8	3.0	23	15	9-1/8	7-1/2	3-1/2	4-3/4		
2	0.8	33D17	45	0.8	3.4	23	19	9-7/8	7-7/8	3-3/4	5-3/4	10	
	1.2	† 133D17	65	1.2	4.2	33	19	9-7/8	7-7/8	3-3/4	5-3/4		

When you order please supply the following:

- Pipe Size
- Valve Type
- Voltage (AC or DC)
- Hertz
- Fluid
- Fluid Temperature
- Max. Diff. Pressure
- Optional Features

(See pages 26 & 27)

† UL Listed Valves - Consult Factory

MAGNATROL VALVE CORPORATION

Magnatrol Valve Corporation • P.O. Box 17 • 67 Fifth Avenue • Hawthorne • New Jersey • 07507
info@magnatrol.com • Phone: 973-427-4341 • Fax: 973-427-7611 • www.magnatrol.com

STRAINERS

Bronze • Stainless Steel



APPLICATION:

The presence of foreign particles in an automatic valve may seriously affect its dependability. The installation of a strainer close to the inlet side of the valve is the best means of preventing the entrance of pipe chips, scale, rust, pipe dope, welding slag or sediment into the valve, provided the screen is periodically removed for cleaning.

CONSTRUCTION:

Strainer bodies have screwed ends. Screens are stainless steel with opening sizes as listed in tables below. Other sizes can be furnished upon request. Liberal straining area provides for fluid passage at minimum pressure drop. Screens are easily removed for cleaning. Strainers are furnished with NPT blow-off connections unplugged. See charts below for blow-off sizes (C Dim.)

CLEANING FOR CRYOGENIC & OXYGEN SERVICE:

- Strainers for Cryogenic applications are degreased and cleaned to keep them free of moisture.
- Strainers for Oxygen service are degreased and cleaned then “black light” tested.



BRONZE 1/4" TO 3" PIPE SIZE

Pipe Size Inches	Screen Size	Type No.	Ship Wt. Lbs.	Dimensions In Inches		
				A	B	C
1/4	60 Mesh 0.009 Openings	BR 0	3/4	2-3/4	2-1/4	1/4
3/8		BR 1	3/4	2-3/4	2-1/4	1/4
1/2		BR 2	3/4	2-3/4	2-1/4	1/4
3/4		BR 3	1-1/2	3	2-9/16	3/8
1	0.16 Diameter Perforations Lined With 30 Mesh	BR 4	2-1/4	3-3/4	2-3/4	3/8
1-1/4		BR 5	3-1/4	4-7/16	3-5/8	3/4
1-1/2		BR 6	4-1/2	4-15/16	3-7/8	3/4
2		BR 7	7	6-1/8	5-1/16	1
2-1/2		BR 8	12-1/2	8-1/4	6	1-1/4
3	BR 9	18	9	6-3/4	1-1/2	

STAINLESS STEEL 1/2" TO 2" PIPE SIZE

Pipe Size Inches	Screen Size	Type No.	Ship Wt. Lbs.	Dimensions In Inches		
				A	B	C
1/2	60 Mesh 0.009 Openings	SS 2	1-1/2	3	2-3/8	1/4
3/4		SS 3	2-1/4	3-3/4	2-13/16	3/8
1		SS 4	3-1/4	4-5/8	3-1/8	3/8
1-1/2	0.16 Diameter Perforations Lined w/30 Mesh	SS 6	6-3/4	5-5/8	4-3/4	3/4
2		SS 7	11-1/2	7	6	1

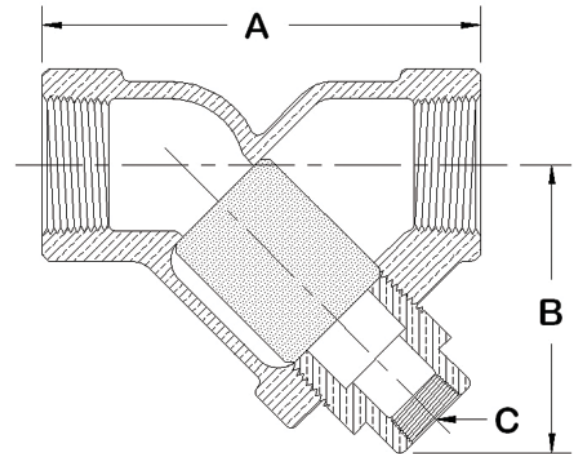

PRESSURE TEMPERATURE RATINGS

MATERIAL	STEAM	LIQUIDS
BRONZE	300 PSI @ 400°F	600 PSI @ 100°F
STAINLESS STEEL	845 PSI @ 750°F	1,440 PSI @ 100°F



STAINLESS STEEL SOLENOID VALVES

Dependable • Packless

TYPE "J" - NORMALLY CLOSED

3/8" TO 1/2" PIPE SIZE

NO DIFFERENTIAL PRESSURE REQUIRED TO OPEN

DIRECT ACTING - ORIFICE SIZES 1/8" TO 3/8"

OPERATION:

Valve opens when energized and closes when de-energized. In this direct acting valve, when the coil is energized, the stem is lifted from its conical seat by the plunger.

CONSTRUCTION: (*Wetted parts)

- *Valve Body - 304 Stainless Steel Globe Pattern - NPT ends
- Coil Enclosure - Malleable Iron, 1/2" NPT conduit conn.
- *Plunger - 430 Stainless Steel
- *Valve Stem - 303 Stainless Steel
- *Bonnet Tube - 304 Stainless Steel
- *Spring - Inconel
- *Body Seal - Non Asbestos Gasket
- *Orifice Seal - Metal to Metal
- *AC Shading Coil - Silver
- *Stem Pin - Inconel
- Coil - Encapsulated Class H, 18" leads

APPLICATION:

To control the flow of **Steam, Hot Liquids, Hot Gases, Cryogenics and any other fluids not reactive with construction materials and free of sidement.** Cryogenic fluids include liquid oxygen (-297°F), liquid argon(-303°F) and liquid nitrogen (-320°F). Valve operates from zero to maximum differential pressure indicated in table. Valve must be mounted in horizontal pipe with solenoid enclosure vertical and on top.

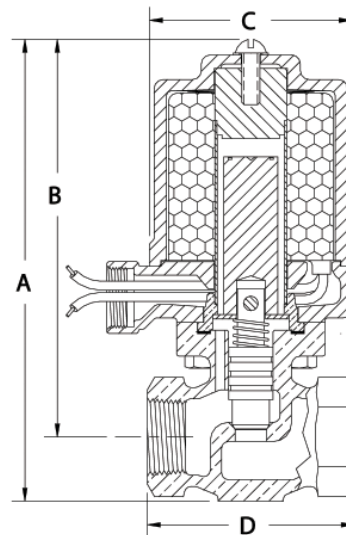

FOR OPTIONS AND ACCESSORIES SEE PAGES 26 & 27

Pipe Size Inches	Max. Diff. PSI	Valve Port Size	Type No.	Watts AC	Amps Hold 120-60	Amps Inrush 120-60	Watts DC	Ship Wt. Lbs.	Dimensions In Inches			
									A	B	C	D
3/8	25	3/8	10J21	25	0.4	1.1	18	6	6-1/4	5-1/2	2-7/8	2-3/4
	75	3/16	10J51									
	150	1/8	10J61									
	50	3/8	25J21	45	0.8	2.3	23	10	7-1/8	6-3/8	3-1/2	2-3/4
	150	3/16	25J51									
300	1/8	25J61										
1/2	25	3/8	10J22	25	0.4	1.2	18	6	6-1/4	5-1/2	2-7/8	2-3/4
	75	3/16	10J52									
	150	1/8	10J62									
	50	3/8	25J22	45	0.8	2.4	23	10	7-1/8	6-3/8	3-1/2	2-3/4
	150	3/16	25J52									
	300	1/8	25J62									

**Optional "Soft Seat" Orifice Seal:
(for applications requiring tight seating):**

- **Viton** - Suitable for Fuel Oils, Gaseous Oxygen and other compatible fluids

**** CLEANING**

- Cryogenic valves are degreased & cleaned to keep them free of moisture.
- Oxygen valves are also "black light" tested.

Strainers are recommended for use with solenoid valves (See page 19)

When you order please supply the following:

- Pipe Size
 - Valve Type
 - Voltage (AC or DC)
 - Hertz
 - Fluid
 - Fluid Temperature
 - Max. Diff. Pressure
 - Optional Features
- (See pages 26 & 27)

STAINLESS STEEL SOLENOID VALVES

Dependable • Packless



TYPE "JR" - NORMALLY OPEN

3/8" TO 1/2" PIPE SIZE

NO DIFFERENTIAL PRESSURE REQUIRED TO OPEN

DIRECT ACTING - ORIFICE SIZES 1/8" TO 3/8"

OPERATION:

Valve closes when energized and opens when de-energized. In this direct acting valve, when the coil is energized, the stem is pressed into its conical seat by the plunger.

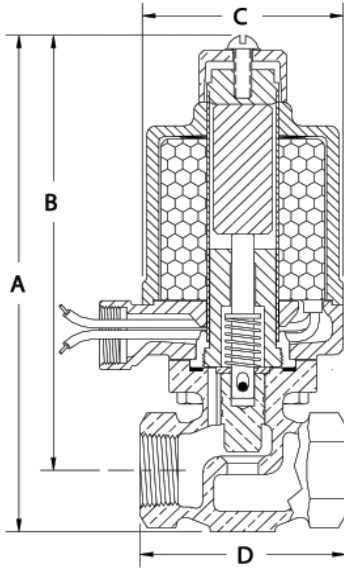

CONSTRUCTION: (*Wetted parts)

- *Valve Body - 304 Stainless Steel Globe Pattern - NPT ends
- Coil Enclosure - Malleable Iron, 1/2" NPT conduit conn.
- *Plunger - 430 Stainless Steel
- *Poppet - 304 Stainless Steel
- *Stem - 303 Stainless Steel
- *Bonnet Tube - 304 Stainless Steel
- *Spring - Inconel
- *Body Seal - Non Asbestos Gasket
- *Orifice Seal - Metal to Metal
- *AC Shading Coil - Silver
- *Stem Pin - Inconel
- Coil - Encapsulated Class H, 18" leads

APPLICATION:

To control the flow of Steam, Hot Liquids, Hot Gases, Cryogenics and any other fluids not reactive with construction materials and free of sidentment. Cryogenic fluids include liquid oxygen (-297°F), liquid argon (-303°F) and liquid nitrogen (-320°F). Valve operates from zero to maximum differential pressure indicated in table. Valve must be mounted in horizontal pipe with solenoid enclosure vertical and on top.



FOR OPTIONS AND ACCESSORIES SEE PAGES 26 & 27

**** CLEANING**

- Cryogenic valves are degreased & cleaned to keep them free of moisture.
- Oxygen valves are also "black light" tested.

Strainers are recommended for use with solenoid valves (See page 19)

When you order please supply the following:

- Pipe Size
- Valve Type
- Voltage (AC or DC)
- Hertz
- Fluid
- Fluid Temperature
- Max. Diff. Pressure
- Optional Features

(See pages 26 & 27)

Pipe Size Inches	Max. Diff. PSI	Valve Port Size	Type No.	Watts AC	Amps Hold 120-60	Amps Inrush 120-60	Watts DC	Ship Wt. Lbs.	Dimensions In Inches			
									A	B	C	D
3/8	23	3/8	10JR21	25	0.5	1.4	18	7	7	6-1/4	2-7/8	2-3/4
	70	3/16	10JR51									
	135	1/8	10JR61									
	45	3/8	25JR21	45	1.0	2.6	23	10	7-7/8	7-1/8	3-1/2	2-3/4
	135	3/16	25JR51									
300	1/8	25JR61										
1/2	23	3/8	10JR22	25	0.5	1.5	18	7	7	6-1/4	2-7/8	2-3/4
	70	3/16	10JR52									
	135	1/8	10JR62									
	45	3/8	25JR22	45	1.0	2.7	23	10	7-7/8	7-1/8	3-1/2	2-3/4
	135	3/16	25JR52									
300	1/8	25JR62										

**Optional "Soft Seat" Orifice Seal:
(for applications requiring tight seating):**

- **Viton** - Suitable for Fuel Oils, Gaseous Oxygen and other compatible fluids



STAINLESS STEEL SOLENOID VALVES

Dependable • Packless

TYPE "K" FULL PORT - NORMALLY CLOSED 1/2" TO 3" PIPE SIZE

NO DIFFERENTIAL PRESSURE REQUIRED TO OPEN

MAX. FLUID TEMP.
400° F
MAX. STATIC PRESSURE
300 PSI
Except valves listed for 500 PSI

OPERATION:

Valve opens when energized and closes when de-energized. When the coil is energized the pilot valve opens, relieving the pressure above the piston, which is then lifted from its seat by the plunger. Upon de-energizing the coil, a spring closes the pilot valve and opens a bleed passageway to permit pressure to build above the piston and seat it.

CONSTRUCTION:

- (*Wetted parts - No Copper Bearing Alloys in contact with fluid)
- *Valve Body - 304 Stainless Steel Globe Pattern - NPT ends
(For Flanged Ends see Options page 24)
- *Piston - 303 Stainless Steel
- Coil Enclosure - Malleable or Cast Iron, 1/2" NPS conduit conn.
- *Plunger - 430 Stainless Steel
- *Pilot Valve - 303 Stainless Steel
- *Bonnet Tube - 304 Stainless Steel
- *Spring - Inconel
- *Body Seal - Non Asbestos Gasket
- *Orifice Seal - Glass Filled Teflon
- *AC Shading Coil - Silver
- *Stem Pin - Inconel
- Coil - Encapsulated Class H, 18" leads

**FOR
STEAM APPLICATIONS
SEE BULLETIN 3006-W
Page 22**

APPLICATION:

To control the flow of **Corrosive Fluids, Deionized Water, Condensate, Ammonias, Vegetable Oils, Fuel Oils, Cryogenics**, Flammable Liquids.** Cryogenic fluids include liquid oxygen (-297°F), liquid argon (-303°F) and liquid nitrogen (-320°F). Valve operates from zero to maximum differential pressure indicated in table. Valve must be mounted in horizontal pipe with solenoid enclosure vertical and on top.

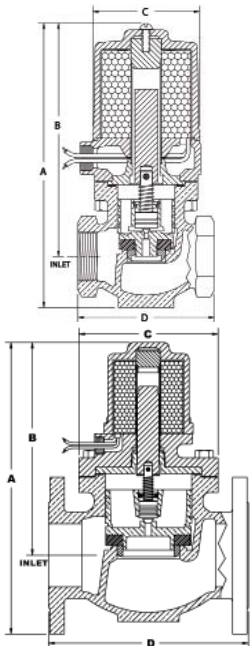

FOR OPTIONS & ACCESSORIES SEE PAGES 26 & 27

Pipe Size Inches	Max. Diff. PSI	Type No.	Watts AC	Amps Hold 120-60	Amps Inrush 120-60	Watts DC	Ship Wt. Lbs.	Dimensions In Inches					
								A	B	C	D NPT	D (Flanged)	
											150#	300#	
1/2	110	14K42	25	0.4	1.2	18	7	7	5-7/8	2-7/8	3-1/4	6	6-1/2
	200	14K32	45	0.8	2.4	23	10	8	6-7/8	3-1/2			
	300	29K52								4			
	500	E29K62	4										
3/4	110	14K43	25	0.4	1.3	18	8	7-1/8	6	2-7/8	3-1/2	6	6-1/2
	200	29K33	45	0.8	2.6	23	11	8-1/8	7	3-1/2			
	300	129K53	65	1.2	3.9	33				16	4		
	500	E129K63					4						
1	110	16K44	25	0.4	1.5	18	10	8	6-5/8	3-1/4	4-1/8	6-1/2	7-1/2
	200	31K34	45	0.8	2.8	23	13	8-7/8	7-1/2	3-1/2			
	300	131K54	65	1.2	4.2	33				18	4		
	500	E131K64					4						
1-1/2	115	35K46	45	0.8	3.2	23	17	10	8-1/8	4	4-7/8	6-1/2	7-1/2
	200	41K36	60	1.2	6.7	35	21	11	9-1/8	4-1/2			
	300	141K56	85	2.0	10.0	45					21	11	9-1/8
	500	141K66					4						
2	100	36K47	45	0.8	3.5	23	27	11	8-3/4	5-3/8	6	8	9
	200	42K37	60	1.2	7.4	35	32	12	9-3/4				
	300	42K57								85	2.0	11.0	45
	500	142K67	4										
3	100	44K49F1	60	1.2	8.8	35	68	13-3/4	10-1/2	6-5/8	N/A	9-1/2	N/A
	200	44K39F1	85	2.0	13.0	45	81					N/A	N/A
	300	144K59F3											

**** CLEANING**

- Cryogenic valves are degreased & cleaned to keep them free of moisture.
- Oxygen valves are also "black light" tested.

Strainers are recommended for use with solenoid valves (See page 19)

When you order please supply the following:

- Pipe Size
 - Valve Type
 - Voltage (AC or DC)
 - Hertz
 - Fluid
 - Fluid Temperature
 - Max. Diff. Pressure
 - Optional Features
- (See pages 26 & 27)

Shipping Weights above apply to Threaded Ends Only (except 3" which are Flanged Only)

For Flanged Ends contact factory for complete weight and dimensions

3" STAINLESS STEEL VALVES ARE SUPPLIED WITH FLANGED ENDS ONLY

STAINLESS STEEL SOLENOID VALVES

Dependable • Packless



TYPE "KR" FULL PORT - NORMALLY OPEN 1/2" TO 3" PIPE SIZE

NO DIFFERENTIAL PRESSURE REQUIRED TO OPEN

**MAX. FLUID TEMP.
400° F**
**MAX. STATIC PRESSURE
300 PSI**
Except valves listed for 500 PSI

OPERATION:

Valve closes when energized and opens when de-energized. When the coil is energized the plunger presses the poppet, closing the pilot orifice, and opens a bleed passageway to permit pressure to build above the piston and seat it. Upon de-energizing the coil, the pilot orifice is opened, relieving the pressure above the piston allowing it to leave its seat. The bottom spring allows the valve to operate at zero pressure drop.

CONSTRUCTION:

- (*Wetted parts - No Copper Bearing Alloys in contact with fluid)
- *Valve Body - 304 Stainless Steel Globe Pattern - NPT ends
(For Flanged Ends see Options page 24)
- *Piston - 303 Stainless Steel
- Coil Enclosure - Malleable or Cast Iron, 1/2 " NPS conduit conn.
- *Plunger - 430 Stainless Steel
- *Poppet - 303 Stainless Steel
- *Stem - 303 Stainless Steel
- *Bonnet Tube - 304 Stainless Steel
- *Spring - Inconel
- *Body Seal - Non Asbestos Gasket
- *Orifice Seal - Glass Filled Teflon
- *AC Shading Coil - Silver
- *Stem Pin - 304 Stainless Steel
- Coil - Encapsulated Class H, 18" leads

**FOR
STEAM APPLICATIONS
SEE BULLETIN 3006-WR
Page 23**

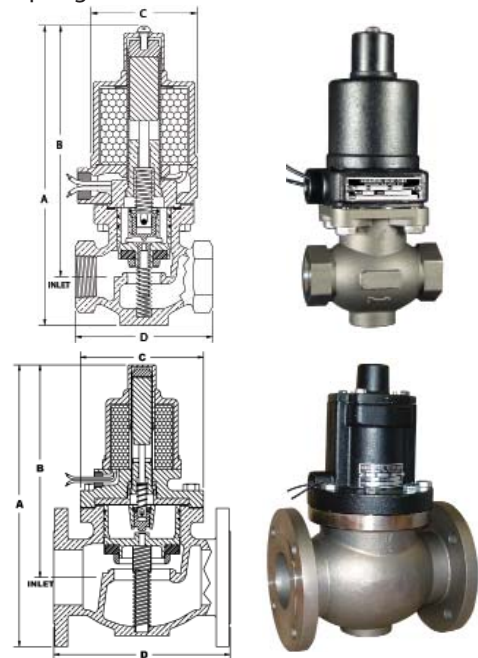

APPLICATION:

To control the flow of Corrosive Fluids, Deionized Water, Condensate, Ammonias, Vegetable Oils, Fuel Oils, Cryogenics, Flammable Liquids.** Cryogenic fluids include liquid oxygen (-297°F), liquid argon (-303°F) and liquid nitrogen (-320°F). Valve operates from zero to maximum differential pressure indicated in table. Valve must be mounted in horizontal pipe with solenoid enclosure vertical and on top.

**** CLEANING**

- Cryogenic valves are degreased & cleaned to keep them free of moisture.
- Oxygen valves are also "black light" tested.

Strainers are recommended for use with solenoid valves

(See page 19)

When you order please supply the following:

- Pipe Size
- Valve Type
- Voltage (AC or DC)
- Hertz
- Fluid
- Fluid Temperature
- Max. Diff. Pressure
- Optional Features

(See pages 26 & 27)

FOR OPTIONS & ACCESSORIES SEE PAGES 26 & 27

Pipe Size Inches	Max. Diff. PSI	Type No.	Watts AC	Amps Hold 120-60	Amps Inrush 120-60	Watts DC	Ship Wt. Lbs.	Dimensions In Inches					
								A	B	C	D	D (Flanged)	
												150#	300#
1/2	110	14KR42	25	0.5	1.5	18	7	8-1/8	7	2-7/8	3-1/4	6	6-1/2
	200	14KR32											
	300	29KR52	45	1.0	2.7	23	10	9-1/8	8	3-1/2			
	500	E29KR62								4			
3/4	110	14KR43	25	0.5	1.6	18	8	8-1/4	7-1/8	2-7/8	3-1/2	6	6-1/2
	200	29KR33											
	300	129KR53	65	1.5	4.3	33	12	9-1/4	8-1/8	3-1/2			
	500	E129KR63								4			
1	110	16KR44	25	0.5	1.8	18	10	9-1/8	7-3/4	3-1/4	4-1/8	6-1/2	7-1/2
	200	31KR34											
	300	131KR54	65	1.5	4.5	33	14	10	8-5/8	3-1/2			
	500	E131KR64								4			
1-1/2	115	35KR46	45	1.0	3.8	23	18	11-3/8	9-1/2	4	4-7/8	6-1/2	7-1/2
	200	41KR36											
	300	141KR56	85	3.5	9.7	45	22	11-5/8	9-3/4	4-1/2			
	500	141KR66								4			
2	100	36KR47	45	1.0	4.2	23	27	12-3/8	10-1/8	5-3/8	6	8	9
	200	42KR37											
	300	42KR57	85	3.5	11.0	45	32	12-5/8	10-3/8				
	500	142KR67											
3	100	44KR49F1	60	1.7	8.8	35	69	14-3/8	11-1/8	6-5/8	N/A	9-1/2	N/A
	200	44KR39F1											
	300	144KR59F3	85	3.5	13.0	45	82	N/A	12-1/2				

Shipping Weights above apply to Threaded Ends Only (except 3" which are Flanged Only)

For Flanged Ends contact factory for complete weight and dimensions

3" STAINLESS STEEL VALVES ARE SUPPLIED WITH FLANGED ENDS ONLY

MAGNATROL VALVE CORPORATION



STAINLESS STEEL SOLENOID VALVES

Dependable • Packless

TYPE "W" FULL PORT - NORMALLY CLOSED 1/2" TO 3" PIPE SIZE

NO DIFFERENTIAL PRESSURE REQUIRED TO OPEN

MAX. FLUID TEMP.
400° F
MAX. STATIC PRESSURE
200 PSI

OPERATION:

Valve opens when energized and closes when de-energized. When the coil is energized the pilot valve opens, relieving the pressure above the piston, which is then lifted from its seat by the plunger. Upon de-energizing the coil, a spring closes the pilot valve and opens a bleed passageway to permit pressure to build above the piston and seat it.

CONSTRUCTION:

- (*Wetted parts - No Copper Bearing Alloys in contact with fluid)
- *Valve Body - 304 Stainless Steel Globe Pattern - NPT ends
(For Flanged Ends see Options page 24)
- *Piston - 303 Stainless Steel
Coil Enclosure - Malleable or Cast Iron, 1/2" NPS conduit conn.
- *Plunger - 430 Stainless Steel
- *Pilot Valve - 303 Stainless Steel
- *Bonnet Tube - 304 Stainless Steel
- *Spring - Inconel
- *Body Seal - Non Asbestos Gasket
- *Orifice Seal - Glass Filled Teflon
- *AC Shading Coil - Silver
- *Stem Pin - Inconel
Coil - Encapsulated Class H, 18" leads

APPLICATION:

To control the flow of STEAM. Steam must be free of sediment. Valve operates from zero to maximum differential pressure indicated in table. Valve must be mounted in horizontal pipe with solenoid enclosure vertical and on top.

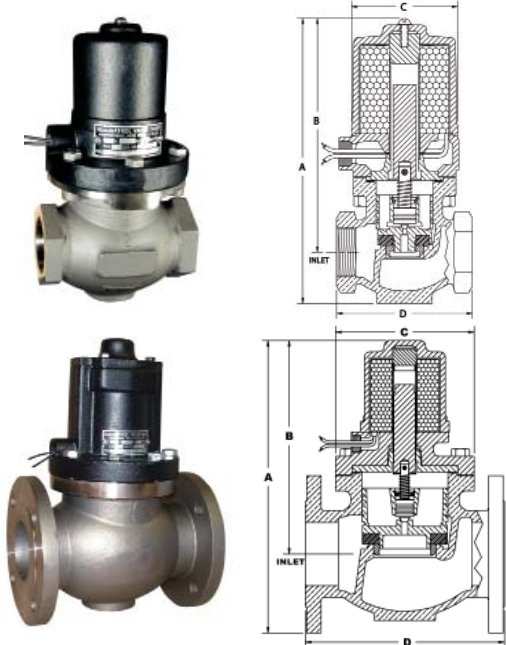

FOR OPTIONS & ACCESSORIES
SEE PAGES 26 & 27

Pipe Size Inches	Max. Diff. PSI	Type No.	Watts AC	Amps Hold 120-60	Amps Inrush 120-60	Watts DC	Ship Wt. Lbs.	Dimensions In Inches				
								A	B	C	D	D (Flanged) 150#
1/2	90	14W22	25	0.4	1.2	18	7	7	5-7/8	2-7/8	3-1/4	6
	140	114W42	40	0.6	1.8	28		8	6-7/8	3-1/2		
	180	129W42	65	1.2	3.6	33		10	8	6-7/8		
3/4	50	14W23	25	0.4	1.3	18	8	7-1/8	6	2-7/8	3-1/2	6
	110	114W43	40	0.6	2.0	28		8-1/8	7	3-1/2		
	180	129W43	65	1.2	3.9	33		11	8-1/8	7		
1	25	16W14	25	0.4	1.5	18	10	8	6-5/8	3-1/4	4-1/8	6-1/2
	50	116W24	40	0.6	2.3	28		8	6-5/8	3-1/4		
	90	116W44	40	0.6	2.3	28		8	6-5/8	3-1/4		
	180	131W44	65	1.2	4.2	33		13	8-7/8	7-1/2		
1-1/2	25	35W16	45	0.8	3.2	23	17	10	8-1/8	4	4-7/8	6-1/2
	50	35W26	45	0.8	3.2	23		10	8-1/8	4		
	90	135W46	65	1.2	4.8	33		11	9-1/8	4-1/2		
	180	141W46	85	2.0	10.0	45		21	11	9-1/8		
2	25	36W17	45	0.8	3.5	23	27	11	8-3/4	5-3/8	6	8
	50	36W27	45	0.8	3.5	23		11	8-3/4			
	115	42W47	60	1.2	7.4	35		12	9-3/4			
	180	142W47	85	2.0	11.0	45		32	12			
3	25	44W19F1	60	1.2	8.8	35	68	13-3/4	10-1/2	6-5/8	N/A	9-1/2
	50	44W29F1										
	100	44W49F1										
	150	144W49F1										

Strainers are recommended for use with solenoid valves (See page 19)

When you order please supply the following:

- Pipe Size
 - Valve Type
 - Voltage (AC or DC)
 - Hertz
 - Fluid
 - Fluid Temperature
 - Max. Diff. Pressure
 - Optional Features
- (See pages 26 & 27)

Shipping Weights above apply to Threaded Ends Only (except 3" which are Flanged Only)
For Flanged Ends contact factory for complete weight and dimensions
3" STAINLESS STEEL VALVES ARE SUPPLIED WITH FLANGED ENDS ONLY

STAINLESS STEEL SOLENOID VALVES

Dependable • Packless



TYPE "WR" FULL PORT - NORMALLY OPEN 1/2" TO 3" PIPE SIZE

NO DIFFERENTIAL PRESSURE REQUIRED TO OPEN

OPERATION:

Valve closes when energized and opens when de-energized. When the coil is energized the plunger presses the poppet, closing the pilot orifice, and opens a bleed passageway to permit pressure to build above the piston and seat it. Upon de-energizing the coil, the pilot orifice is opened, relieving the pressure above the piston allowing it to leave its seat. The bottom spring allows the valve to operate at zero pressure drop.

CONSTRUCTION:

(*Wetted parts - No Copper Bearing Alloys in contact with fluid)

*Valve Body - 304 Stainless Steel Globe Pattern - NPT ends

(For Flanged Ends see Options page 24)

*Piston - 303 Stainless Steel

Coil Enclosure - Malleable or Cast Iron, 1/2" NPS conduit conn.

*Plunger - 430 Stainless Steel

*Poppet - 303 Stainless Steel

*Stem - 303 Stainless Steel

*Bonnet Tube - 304 Stainless Steel

*Spring - Inconel

*Body Seal - Non Asbestos Gasket

*Orifice Seal - Glass Filled Teflon

*AC Shading Coil - Silver

*Stem Pin - 304 Stainless Steel

Coil - Encapsulated Class H, 18" leads

MAX. FLUID TEMP.

400° F

MAX. STATIC PRESSURE

200 PSI

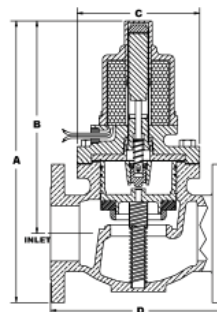
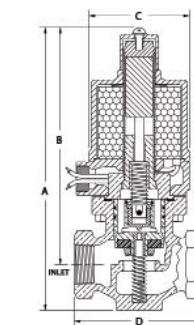

**FOR OPTIONS & ACCESSORIES
SEE PAGES 26 & 27**

APPLICATION:

To control the flow of STEAM. Steam must be free of sediment. Valve operates from zero to maximum differential pressure indicated in table. Valve must be mounted in horizontal pipe with solenoid enclosure vertical and on top.

Strainers are recommended for use with solenoid valves (See page 19)

When you order please supply the following:

- Pipe Size
- Valve Type
- Voltage (AC or DC)
- Hertz
- Fluid
- Fluid Temperature
- Max. Diff. Pressure
- Optional Features

(See pages 26 & 27)

Pipe Size Inches	Max. Diff. PSI	Type No.	Watts AC	Amps Hold 120-60	Amps Inrush 120-60	Watts DC	Ship Wt. Lbs.	Dimensions In Inches					
								A	B	C	D	D (Flanged) 150#	
1/2	90	14WR22	25	0.5	1.5	18	7	8-1/8	7	2-7/8	3-1/4	6	
	140	114WR42	40	0.8	2.4	28		9-1/8	8	3-1/2			
	180	129WR42	65	1.5	4.2	33		10	9-1/4	8-1/8			3-1/2
3/4	50	14WR23	25	0.5	1.6	18	8	8-1/4	7-1/8	2-7/8	3-1/2	6	
	110	114WR43	40	0.8	2.6	28		9-1/4	8-1/8	3-1/2			
	180	129WR43	65	1.5	4.3	33		12	9-1/4	8-1/8			3-1/2
1	25	16WR14	25	0.5	1.8	18	10	9-1/8	7-3/4	3-1/4	4-1/8	6-1/2	
	50	116WR24	40	0.8	2.9	28		10	9-1/8	7-3/4			3-1/4
	90	116WR44	40	0.8	2.9	28		10	9-1/8	7-3/4			3-1/4
	180	131WR44	65	1.5	4.5	33		14	10	8-5/8			3-1/2
1-1/2	25	35WR16	45	1.0	3.8	23	18	11-3/8	9-1/2	4	4-7/8	6-1/2	
	50	35WR26	45	1.0	3.8	23		11-3/8	9-1/2	4			
	90	135WR46	65	1.5	5.7	33		11-3/8	9-1/2	4			
	180	141WR46	85	3.5	9.7	45		22	11-5/8	9-3/4			4-1/2
2	25	36WR17	45	1.0	4.2	23	27	12-3/8	10-1/8	5-3/8	6	8	
	50	36WR27	45	1.0	4.2	23		12-3/8	10-1/8				
	115	42WR47	60	1.7	7.3	35		32	12-5/8				10-3/8
3	25	44WR19F1	60	1.7	8.8	35	69	14-3/8	11-1/8	6-5/8	N/A	9-1/2	
	50	44WR29F1											
	100	44WR49F1											
	150	144WR49F1											

Shipping Weights above apply to Threaded Ends Only (except 3" which are Flanged Only)
For Flanged Ends contact factory for complete weight and dimensions
3" STAINLESS STEEL VALVES ARE SUPPLIED WITH FLANGED ENDS ONLY

MAGNATROL VALVE CORPORATION



OPTIONAL FEATURES

For Dependable • Packless Solenoid Valves

See Individual Options For Availability For Use With Specific Valve Types

BOTTOM MOUNTED OPTIONS Note: Only One Bottom Mount Option Can Be Installed On Each Valve

MANUAL OVERRIDE

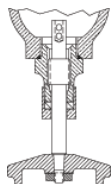

(Normally Closed valves only)
(Designated by Prefix "MO")
Enables manual opening of solenoid valve during power failure or to override automatic controls.

LEVER

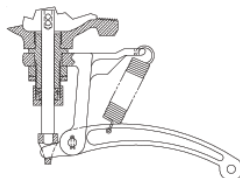

(Normally Closed valves only)
(Designated by Prefix "LV")
Enables rapid opening of solenoid valve. Can be chain operated for use at inaccessible locations.

DASHPOT

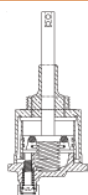

(Designated by Prefix "DP")
Furnished for clean liquids to reduce water hammer effect sometimes encountered in long pipe runs by slowing valve closing.

FLOW CONTROL

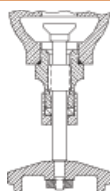

(Normally Closed, NR & MR valves, only)
(Designated by Prefix "FC")
Provides a manual method of reducing or throttling the flow.

MOUNTING STUD

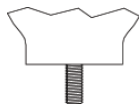

(Designated by Prefix "MS")
3/8"-16 thread can be furnished in bottom of body to facilitate mounting on bracket. (Not available on 2", 2-1/2" and 3")

DRAIN



(Normally Closed, NR & MR valves, only)
(Designated by Prefix "DR") - 1/4" NPT plug supplied in bottom of valve to facilitate draining of liquid

OTHER OPTIONS

PILOT TAP



(Designated by Prefix "PT")
Type D, G & GR Valves can be furnished with 1/8" tapped hole for pilot connection or pressure gauge.

DIN CONNECTOR

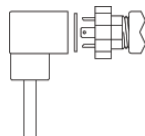

(Designated by Suffix "DN")
Provides 3 prong connector for easy power connect / disconnect.
Not available for Explosion-Proof.

"HUM FREE": (No AC Hum/Buzz)

(Designated by Suffix "HF") - The "HUM FREE" option eliminates the "AC hum" associated with AC operated solenoid valves. Enables valves to be used where an AC hum would not be acceptable and AC is the only power source available. IE: Hospitals, labs, schools (class rooms), homes, office environments etc. & when 24 vac is required for 40 series valves.

Leak / Dead Tight:

(Normally Closed valves only)
(Designated by Suffix "LT") - The Leak / Dead Tight Option offers 'soft' resilient seating or 'gapless' seal for low pressure applications 50 PSI or less. Consult Factory for Max. Diff. Pressure and Valve Type availability.

Flanged Ends for Bronze and Stainless Steel Valves:

(Designated by Suffix "F1" for 150 lb or "F3" for 300 lb Flanges)
F1 or F3 Flanged ends available on all stainless steel valves. F1 Flanged ends available on bronze valves. F3 Flanged ends for bronze valves available through our Clark-Cooper Division.

Explosion-Proof and Watertight Solenoids:

(Designated by Prefix "F") - are Explosion-proof and NEMA 4, 7C & D, 9E, F & G suitable for use in hazardous locations requiring Class I, Groups C & D & Class II Groups E, F, and G equipment.

NEMA 4X:

(Designated by Prefix "F" AND Suffix "ZP") - are suitable for use in locations requiring a NEMA 4X designation. "ZP" (Zinc Plating) replaces the standard paint used on the Coil housing (cup and base). The additional corrosion protection satisfies NEMA 4X requirements. Internal construction, pressure ratings, power consumption, and external dimensions are the same as for standard valves.

Nickel Plating:

(Designated by Suffix "NP") - Plating is 0.0005" Thick Meets Mil Spec. C26074

Universal Mount Valves For Mounting In Vertical Pipe Runs
(See Magnatrol Universal Mount Catalog 3006-UM)

POSITION INDICATORS

For Normally Closed Solenoid Valves



Position Switches

CONSTRUCTION:

Housing - 316 Stainless Steel with 1/2" NPT Conduit Connection

Contact - SPDT (Single Pole/Double Throw)

Lead Wires - 36 inches long, 18 gauge standard leads potted-in PVC

OPERATION:

Switch is activated by a ferromagnetic "target" attached to the valve's piston



PS shown with valve body adaptor

"PS" - General Purpose/NEMA 4, 4X
"PSF" - Explosion Proof

SPDT Contact

Electrical Rating:

4A @ 120 VAC / 3A @ 24 VDC

2A @ 240 VAC / 1.25A @ 48 VDC

0.5A @ 125 VDC & 250 VDC

The PS and PSF can be wired AC or DC, N/O or N/C, consume no power to operate, and leave no current leakage or voltage drop



PS General Purpose & Water Tight (SPDT Switch) shown on 3" Stainless Steel Valve

Position Switches With LED Visual Indication



Position Switch on right shown energizing Red LED

"PL" - General Purpose/NEMA 4, 4X
"PLF" - Explosion Proof

SPDT Contact

Electrical Rating:

0.25A @ 120 VAC / 3A @ 24 VDC

(3A @ 120 VAC / 2A @ 24 VDC without the LEDs)

The PL and PLF can be wired AC or DC, N/O or N/C

Ambiant Temperature: -40°F to 221°F (106°C)

NOTE: ONLY ONE BOTTOM MOUNTED OPTION CAN BE INSTALLED ON EACH VALVE

For multiple switches and where a switch and a bottom mounted option are required, contact our Clark Cooper Division.

(See bottom of Page 3)

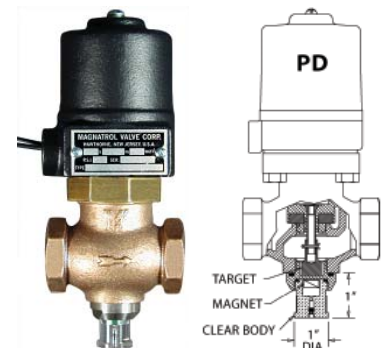

Position Display - Visual Indication ONLY

"PD" - General Purpose / NEMA 4, 4X / Explosion Proof

CONSTRUCTION:

Housing - Clear High-Strength Polycarbonate

APPLICATION:

Visual indication that valve is Open / Closed

OPERATION:

When the valve is in the closed position, a ferromagnetic "target" attached to the valve's piston, lifts a green colored magnet into the adapter hiding it from view. When the valve is energized, (open position), the magnet drops down to a visible position.

Position Indicators for Normally Closed Valve Only
Available on Type A, S, L, K, W & G Valves

HOW TO ORDER:

Indicate Option when Ordering:

Use the appropriate Prefix:
 PS, PSF, PL, PLF, or PD

Example:

PS18A44 indicates a Position Switch mounted on a Type 18A44 valve.



BRONZE SOLENOID VALVES

Dependable • Packless

TYPE "P" FULL PORT - NORMALLY CLOSED 1/2" TO 1-1/2" PIPE SIZE

NO DIFFERENTIAL PRESSURE REQUIRED TO OPEN

MAX. FLUID TEMP.
212° F
MAX. STATIC PRESSURE
300 PSI
Except valves listed for 500 PSI



OPERATION:

Valve opens when energized and closes when de-energized. When the coil is energized the pilot valve opens, relieving the pressure above the piston, which is then lifted from its seat by the plunger. Upon de-energizing the coil, a spring closes the pilot valve and opens a bleed passageway to permit pressure to build "above" the piston and seat it.

CONSTRUCTION: (* Wetted parts)

- *Valve Body - Cast Bronze, Globe Pattern - NPT ends
- *Piston - Bronze
- Coil Enclosure - Malleable Iron, 1/2" NPS conduit conn.
- *Plunger - 430 Stainless Steel
- *Plunger Spring - 304 Stainless Steel
- *Pilot Valve - 303 Stainless Steel
- *Bonnet Tube - 304 Stainless Steel
- *Spring - 302 Stainless Steel
- *Body Seal - Buna N or Non Asbestos Gasket
- *Orifice Seal - Buna N (Viton or Glass Filled Teflon available)
- *
- *

APPLICATION:

To control the flow of Water, Oil, Air, Gas, Solvents, Brine, Vacuum and any other fluids not reactive with construction materials and free of sediment. Valve operates from zero to maximum differential pressure indicated in table. Valve can be mounted in ANY POSITION (See box at right).

The "P" Valve is:

Multipoised:
Ability to be mounted in any position.

Spring Loaded:
The term used to indicate that the valve has a plunger spring. A spring-loaded plunger permits the valve to be mounted in any position without causing malfunction.

Pipe Size Inches	Max Diff. PSI	Type No.	Watts	Ship Wt. Lbs.	Dimension In Inches			
					A	B	C	D
1/2	110	118P42HF	28	8	7	5-7/8	2-3/4	3-1/4
	200	118P32HF						
	300	118P52HF						
3/4	50	118P23HF	28	8	7-1/2	6	2-3/4	3-1/2
	110	118P43HF						
	200	133P33HF	33	12	8-1/8	7	4-1/8	
	300	133P53HF						
1	50	118P24HF	28	10	7-7/8	6-5/8	2-3/4	4-1/8
	110	118P44HF						
	200	133P34HF	33	14	8-7/8	7-1/2	3-1/2	
	300	133P54HF						
1-1/2	115	41P46HF	35	24	11	9-1/8	4-1/2	4-7/8
	200	41P36HF						
	300	41P56HF						

FOR OPTIONS & ACCESSORIES SEE PAGES 26 & 27

Strainers are recommended for use with solenoid valves (See page 19)

When you order please supply the following:

- Pipe Size
 - Valve Type
 - Voltage (AC or DC)
 - Hertz
 - Fluid
 - Fluid Temperature
 - Max. Diff. Pressure
 - Optional Features
- (See pages 26 & 27)

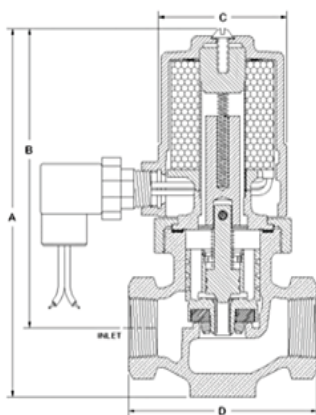

For AC POWER SOURCE
Shown with "HF" Rectifier

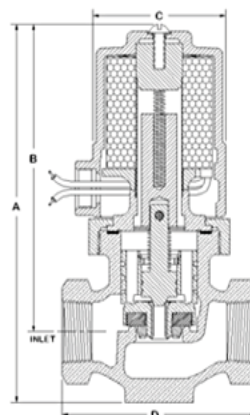

For DC POWER SOURCE
Drop "HF" Suffix. i.e.: 118P44

Explosion Proof:
Available for DC Power Source **ONLY** (Valves without "HF" suffix). Use Prefix "F" (i.e. F118P44).

BRONZE SOLENOID VALVES
Dependable • Packless



“SANDY WELL WATER” FULL PORT - NORMALLY CLOSED
1/2” TO 3” PIPE SIZE

NO DIFFERENTIAL PRESSURE REQUIRED TO OPEN

OPERATION:

Valve opens when energized and closes when de-energized. When the coil is energized the pilot valve opens, relieving the pressure above the piston, which is then lifted from its seat by the plunger. Upon de-energizing the coil, a spring closes the pilot valve and opens a bleed passageway to permit pressure to build above the piston and seat it.

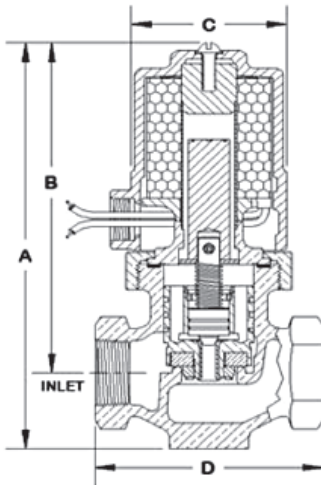

CONSTRUCTION: (* Wetted parts)

- *Valve Body - Cast Bronze, Globe Pattern - NPT ends
- *Piston - Bronze
- Coil Enclosure - Malleable or Cast Iron, 1/2” NPS conduit conn.
- *Plunger - 430 Stainless Steel
- *Pilot Valve - 303 Stainless Steel
- *Bonnet Tube - 304 Stainless Steel
- *Spring - 302 Stainless Steel
- *Body Seal - Buna N or Non Asbestos Gasket
- *Orifice Seal - Buna N (Viton or Glass Filled Teflon available)
- *AC Shading Coil - Copper
- *Stem Pin - Inconel
- Coil - Encapsulated Class B, 18” leads - (Class H available)

APPLICATION:

To control the flow of “Sandy Well Water”, the valve is designed with the piston and other components “turned down”, offering additional clearance, allowing the valve to operate with fluids containing some sediment typically found in well water. Valve operates from zero to maximum differential pressure indicated in table. Valve must be mounted in horizontal pipe with solenoid enclosure vertical and on top.

MAX. FLUID TEMP.
212° F
MAX. STATIC PRESSURE
300 PSI
Except valves listed for 500 PSI



FOR OPTIONS & ACCESSORIES
SEE PAGES 26 & 27

Strainers are recommended for use with solenoid valves (See page 19)

When you order please supply the following:

- Pipe Size
- Valve Type
- Voltage (AC or DC)
- Hertz
- Fluid
- Fluid Temperature
- Max. Diff. Pressure
- Optional Features

(See pages 26 & 27)

Pipe Size Inches	Max Diff. PSI	Type No.	Watts AC	Watts AC	Ship Wt. Lbs.	Dimension In Inches			
						A	B	C	D
1/2	50	18A22-V	25	18	8	7	5-7/8	2-3/4	3-1/4
	80	118A22-V	40	28					
3/4	50	18A23-V	25	18	8	7-1/8	6	2-3/4	3-1/2
	75	118A23-V	40	28					
	125	233A23-V	80	40	12	8-1/8	7	3-1/2	3-1/2
1	50	18A24-V	25	18	10	7-7/8	6-5/8	2-3/4	4-1/8
	75	118A24-V	40	28					
	125	133A24-V	65	33	14	8-7/8	7-1/2	2-3/4	4-1/8
	200	233A24-V	80	N/A					
1-1/4	50	18A25-V	25	18	12	8-3/8	6-3/4	2-3/4	4-1/2
	75	118A25-V	40	28					
	110	133A25-V	65	33					
	300	140A45-V	85	N/A	16	9-3/8	7-3/4	3-1/2	4-1/2
1-1/2	50	35A26-V	45	23	20	10	8-1/8	4	4-7/8
	75	135A26-V	65	33					
	125	41A26-V	60	35	24	11	9-1/8	4-1/2	4-7/8
2	30	36A17-V	45	23	31	11	8-3/4	5-3/8	6
	50	136A17-V	65	33					
	75	136A27-V	65	33					
	125	42A27-V	60	35	36	12	9-3/4	5-3/8	6
	185	142A27-V	85	45					
2-1/2	30	43A18-V	60	35	43	12-7/8	10-1/8	5-7/8	7-1/4
	50	143A18-V	85	45					
	75	243A18-V	115	65					
3	30	44A19-V	60	35	56	13-3/4	10-1/2	6-5/8	8-3/8
	50	144A19-V	85	45					
	75	244A19-V	115	65					

†† Not available for DC operation



BRONZE SOLENOID VALVES

Dependable • Packless

“GRITTY COOLANT” FULL PORT - NORMALLY CLOSED 1/2” TO 1-1/2” PIPE SIZE

NO DIFFERENTIAL PRESSURE REQUIRED TO OPEN

MAX. FLUID TEMP.
212° F
MAX. STATIC PRESSURE
300 PSI
Except valves listed for 500 PSI



OPERATION:

Valve opens when energized and closes when de-energized. When the coil is energized the pilot valve opens, relieving the pressure above the piston, which is then lifted from its seat by the plunger. Upon de-energizing the coil, a spring closes the pilot valve and opens a bleed passageway to permit pressure to build above the piston and seat it.

CONSTRUCTION: (* Wetted parts)

- *Valve Body - Cast Bronze, Globe Pattern - NPT ends
- *Piston - Bronze
- Coil Enclosure - Malleable or Cast Iron, 1/2” NPS conduit conn.
- *Plunger - 430 Stainless Steel
- *Pilot Valve - 303 Stainless Steel
- *Bonnet Tube - 304 Stainless Steel
- *Spring - 302 Stainless Steel
- *Body Seal - Buna N or Non Asbestos Gasket
- *Orifice Seal - Buna N (Viton or Glass Filled Teflon available)
- *AC Shading Coil - Copper
- *Stem Pin - Inconel
- Coil - Encapsulated Class B, 18” leads - (Class H available)

APPLICATION:

To control the flow of “Coolant”, the valve is designed with the piston “turned down” and a larger pilot port, offering additional clearance, allowing the valve to operate with fluids containing some grit/sediment typically found in coolant. Valve operates from zero to maximum differential pressure indicated in table. Valve must be mounted in horizontal pipe with solenoid enclosure vertical and on top.

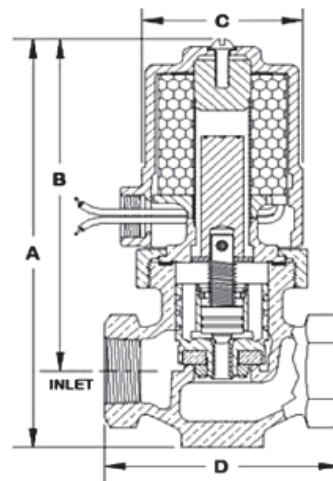

**FOR OPTIONS & ACCESSORIES
SEE PAGES 26 & 27**

Pipe Size Inches	Max Diff. PSI	Type No.	Watts AC	Watts AC	Ship Wt. Lbs.	Dimension In Inches			
						A	B	C	D
1/2	80	MS18A42-C	25	18	8	7	5-7/8	2-3/4	3-1/4
	200	MS33A22-C	40	23					
	300	MS233A42-C	80	40					
3/4	80	MS18A43-C	25	18	8	7-1/8	6	2-3/4	3-1/2
	125	MS33A23-C	45	23					
	200	MS133A23-C	65	33					
	300	MS233A43-C	80	40					
1	200	MS233A24-C	80	40	10	7-7/8	6-5/8	2-3/4	4-1/8
	300	MS233A44-C	80	40					
1-1/4	200	MS233A25-C	80	40	12	8-3/8	6-3/4	2-3/4	4-1/2
	300	MS233A45-C	80	40					
1-1/2	300	MS241A46-C	115	65	20	10	8-1/8	4	4-7/8

“A” Dimension does not include the “MS” Mounting Stud (Approx. 7/8”)

Note: The addition of any bottom mounted option would replace the “MS” Mounting Stud and change the prefix to reflect the appropriate option.

Strainers are recommended for use with solenoid valves (See page 19)

When you order please supply the following:

- Pipe Size
 - Valve Type
 - Voltage (AC or DC)
 - Hertz
 - Fluid
 - Fluid Temperature
 - Max. Diff. Pressure
 - Optional Features
- (See pages 26 & 27)

†† Not available for DC operation

BRONZE SOLENOID VALVES
Dependable • Packless



“GRITTY COOLANT” FULL PORT - NORMALLY OPEN
1/2” TO 1-1/2” PIPE SIZE

NO DIFFERENTIAL PRESSURE REQUIRED TO OPEN

OPERATION:

Valve closes when energized and opens when de-energized. When the coil is energized the plunger presses the poppet, closing the pilot orifice, and opens a bleed passageway to permit pressure to build above the piston and sealing it. Upon de-energizing the coil, the pilot orifice is opened, relieving the pressure above the piston, allowing it to leave its seat. The bottom spring allows the valve to operate at zero pressure drop.

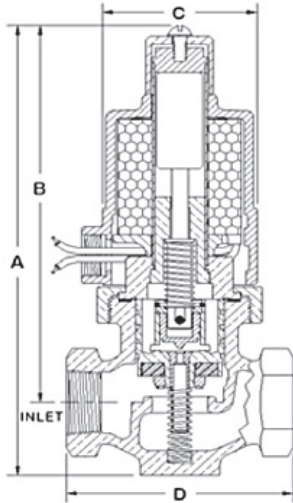

CONSTRUCTION: (* Wetted parts)

- *Valve Body - Cast Bronze, Globe Pattern - NPT ends
- *Piston - Cast Bronze
- Coil Enclosure - Malleable or Cast Iron, 1/2” NPS conduit conn.
- *Plunger - 430 Stainless Steel
- *Poppet - 303 Stainless Steel
- *Stem - 303 Stainless Steel
- *Bonnet Tube - 304 Stainless Steel
- *Spring - Inconel and 302 Stainless Steel
- *Body Seal - Buna N or Non Asbestos Gasket
- *Orifice Seal - Buna N (Viton or Glass Filled Teflon available)
- *AC Shading Coil - Copper
- *Stem Pin - 304 Stainless Steel
- Coil - Encapsulated Class B, 18” leads - (Class H available)

APPLICATION:

To control the flow of **Water, Oil, Air, Gas, Solvents, Brine, Vacuum** and any other fluids not reactive with construction materials and free of sediment. Valve operates from zero to maximum differential pressure indicated in table. Valve must be mounted in horizontal pipe with solenoid enclosure vertical and on top.



MAX. FLUID TEMP.
212° F
MAX. STATIC PRESSURE
300 PSI
Except valves listed for 500 PSI

FOR OPTIONS & ACCESSORIES
SEE PAGES 26 & 27

Strainers are recommended for use with solenoid valves

(See page 19)

Pipe Size Inches	Max Diff. PSI	Type No.	Watts AC	Watts AC	Ship Wt. Lbs.	Dimension In Inches			
						A	B	C	D
1/2	200	MS33AR42-C	45	23	8	9-3/8	8-1/4	4-1/8	3-1/4
	50	MS18AR23-C	25	18	9	8-1/4	7-1/8	2-3/4	3-1/2
3/4	110	MS233AR43-C	80	40	13	9-1/4	8-1/8	3-1/2	3-1/2
	110	MS33AR44-C	45	23					
1	200	MS233AR24-C	80	40	14	10	8-5/8	3-1/2	4-1/8
	300	MS233AR44-C	80	40					

“A” Dimension does not include the “MS” Mounting Stud (Approx. 7/8”)

Note: The addition of any bottom mounted option would replace the “MS” Mounting Stud and change the prefix to reflect the appropriate option.

When you order please supply the following:

- Pipe Size
- Valve Type
- Voltage (AC or DC)
- Hertz
- Fluid
- Fluid Temperature
- Max. Diff. Pressure
- Optional Features

(See pages 26 & 27)

†† Not available for DC operation



REQUEST A QUOTE

Fill In The Information Below

If you have any questions or wish to request a quote:
Phone: 973-427-4341 • Fax: 973-427-7611
E-Mail: info@magnatrol.com

We appreciate the opportunity to quote on your requirements.

For immediate quote – Fill in the information below and CALL: 973-427-4341

For same day quote – Fill in the information below and FAX: 973-427-7611

For quote within 24 hrs – Go online to www.magnatrol.com, and go to Quick Quote

YOUR COMPANY DATA

Company Name: _____ **Phone:** _____

Contact (Your Name): _____ **Fax:** _____

Your RFQ Reference (If Any): _____

Type of Business: OEM Re-Seller Consumer/End User

E-Mail: _____

VALVE DATA

Desired Delivery: _____

Your Reference (Optional): _____

Quantity: _____

Valve Construction Material: Bronze or Stainless Steel

Pipe Size: (1/4" thru 3"): _____

Normally: **Closed** (Energize To Open) or **Open** (Energize To Close)

Voltage: **AC:** _____ Volts/_____ Hz or **DC:** _____ Volts

Maximum Differential Pressure: _____ PSI

Fluid: _____

Maximum Fluid Temperature: _____ °F

Optional Feature: (See Optional Feature Details On Pages 26 & 27)

Choose One (1) Of The Following Per Valve: MO LV DP FC MS DR PD PS PL

Additional Options: HF LT NP PT DN ZP (Can be combined with one (1) of the above Optional Features)

Enclosure Options: General Purpose Explosion Proof NEMA 4 NEMA 4X
(For Solenoid Housing) (Prefix "G" - NEMA 12) (Prefix "F") (Prefix "E") (Prefix "E" & Suffix "ZP")

Comments: _____

Quantity Discounts: Consult Factory

Delivery: Most orders ship in 7-10 days. Small emergency orders can be shipped in 1-2 days.

ORDERING GUIDELINES

Magnatrol Solenoid Valves



If you have any questions or wish to request a quote:
Phone: 973-427-4341 • Fax: 973-427-7611
E-Mail: info@magnatrol.com

MAGNATROL VALVE TYPE NUMBER DETAIL

For Additional Information On Options See Optional Features Pages 26 & 27

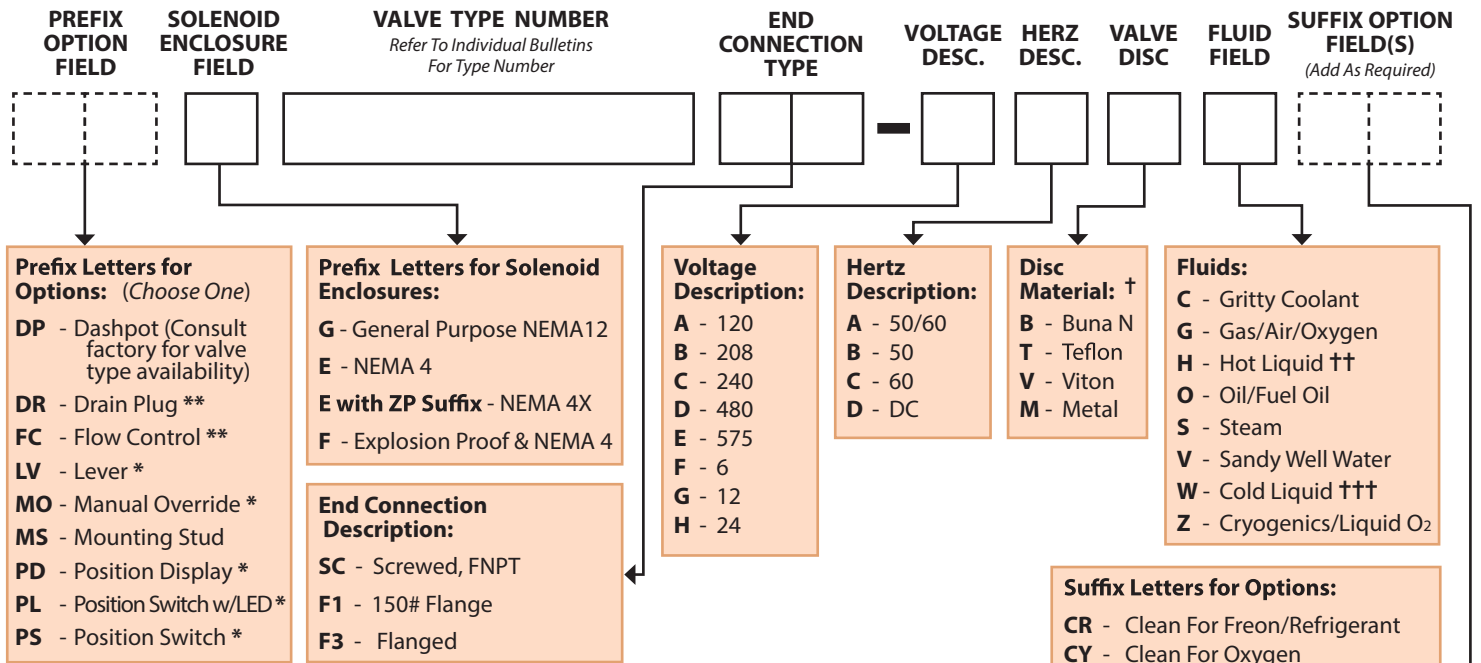

† Refer to Individual Bulletins for Standard Orifice Seal/Disc Material.
NOTE: (For N, NR, M, MR, J & JR this field is used to show a change to the Valve Body Seal Material)

†† Use fluid designation "H" for light liquids up to 400° F. and Brine applications.

††† Use fluid designation "W" for light liquids under 212° F. (i.e. Water, Jet Fuel, Kerosene, Gasoline, Naptha, Alcohol, Soluable Oil, Coolant, Freon and Refrigerant).

* Normally Closed Valves Only

** Normally Closed and NR & MR Valves/FC not available on G valve type

*** Pilot Tap: Can be used along with any other option. Available On Type D, G and GR only.

Consult Factory for Assistance with:

- Additional voltages
- End Connections not shown
- Fluid Field designations



Check individual bulletins for listed valves



TERMS & CONDITIONS OF SALE

CONTACT INFORMATION

Solenoid valve questions can be answered quickly and accurately over the phone:

Phone: 973-427-4341 • Fax: 973-427-7611

TERMS & CONDITIONS OF SALE

- 1. Catalog:** This catalog supersedes all previous issues.
 - 2. Quotations:** Quotations are made for acceptance within 60 days and are subject to change or withdrawal without notice.
 - 3. Prices and Discounts:** All prices and discounts are in accordance with the prices and discounts established by Magnatrol and are subject to change without notice.
 - 4. Terms:** Net 30 days, subject to establishment of credit.
 - 5. Shipments:** All shipments are F.O.B. factory, Hawthorne, New Jersey. Our responsibility ends with delivery of merchandise to the transportation company and issuance to us of formal shipping receipt.
 - 6. Minimum Billing:** Minimum billing charge is \$50.00 net.
 - 7. Cancellations:** Orders are subject to cancellation only with our consent.
 - 8. Shipping Date:** There shall be no liability for default or delay in shipping. All orders, contracts, and agreements are made subject to delays contingent upon accidents, strikes, embargoes or other causes beyond our control.
 - 9. Design and Materials:** All materials and designs are subject to change without notice.
 - 10. Weights and Dimensions:** Weights and dimensions listed in this catalog are as close to actual as is practicable but are not guaranteed and are subject to change without notice.
 - 11. Errors:** All clerical errors are subject to correction.
 - 12. Returns for Repair:** Valves returned for repair must be shipped prepaid and accompanied by a detailed report regarding service application, installation and nature of trouble or malfunction.
 - 13. Returns for Credit:** Returns for credit will be accepted only with our consent. Credit will be subject to restocking charge and any additional expenses incurred in restoring valves to salable condition. Credit will be issued only to original purchaser.
 - 14. Taxes:** Any manufacturer's excise tax, use tax, sales tax or tax or duty of any nature shall be paid by the buyer. In the event that the seller is required to pay any such taxes or duties, the buyer shall reimburse seller therefore. The buyer may provide seller with an exemption certificate or other documents acceptable to taxing or customs authorities at the time an order is placed.
 - 15. Guarantee:** MAGNATROL valves are guaranteed to be free from any defects in material and workmanship for one year or 500,000 cycles, whichever comes first. Our guarantee solely conveys the right to repair or replace free of charge, any defective valves, or parts, thereof, returned to us transportation charges prepaid, within one year after date of original shipment from factory.
- This guarantee shall not apply if the valve has been:**
- Improperly Installed
 - Used for other than intended service
 - Repaired without authorization



Check individual bulletins for listed valves

MAGNATROL CONTACT INFORMATION

Sales, Service, Tech Support: Phone: 973-427-4341
 Fax: 973-427-7611
 Email: info@magnatrol.com
 techsupport@magnatrol.com

Mailing Address: PO Box 17
 Hawthorne, NJ 07507

Shipping Address: 21 Horton Avenue
 Hawthorne, NJ 07506

Administrative: 67 Fifth Avenue
 Hawthorne, NJ 07506

