

Fisher™ 3610J and 3620J Positioners and 3622 Electro-Pneumatic Converter

Fisher 3610J or 3610JP pneumatic and 3620J or 3620JP electro-pneumatic positioners are used in combination with either single or double-acting rotary actuators to accurately position control valves used in throttling applications. The positioner mounts integrally to the actuator housing. These rugged positioners provide a valve position proportional to a pneumatic or a DC current input signal.

The 3610J or 3610JP pneumatic positioner in combination with the Fisher 3622 electro-pneumatic converter becomes the 3620J or 3620JP positioner, respectively. This integral electro-pneumatic converter, can be factory installed or installed in the field on existing positioners. The electro-pneumatic converter receives the DC current input signal and

provides a proportional pneumatic output signal through a nozzle/flapper arrangement.

The output signal from the converter becomes the input signal pressure to the pneumatic positioner, eliminating the need for a remote mounted transducer.

The positioner mounts on the actuator as shown below. Figure 1 shows the cam feedback mechanism for a positioner mounted on the actuator. Positioner bleed air continually purges the enclosure containing the feedback lever and the feedback linkages.

To support diagnostic testing of valve/actuator/positioner packages, connectors, piping, and other hardware can be installed between the 3610J or 3620J positioner and the actuator.

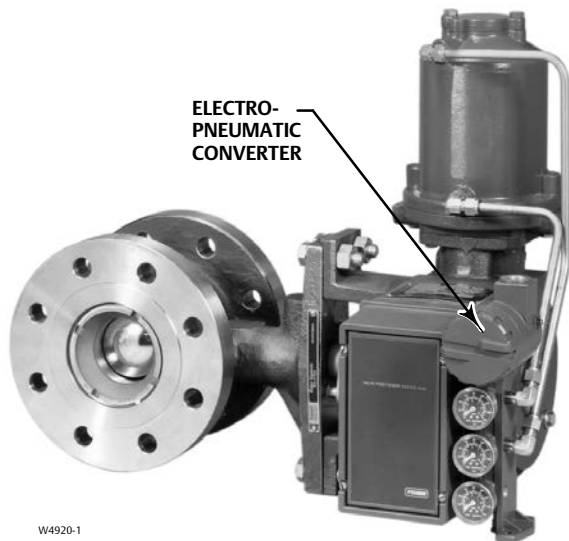

W4920-1

**3620JP ELECTRO-PNEUMATIC POSITIONER
WITH 1061 ACTUATOR AND V500 VALVE**

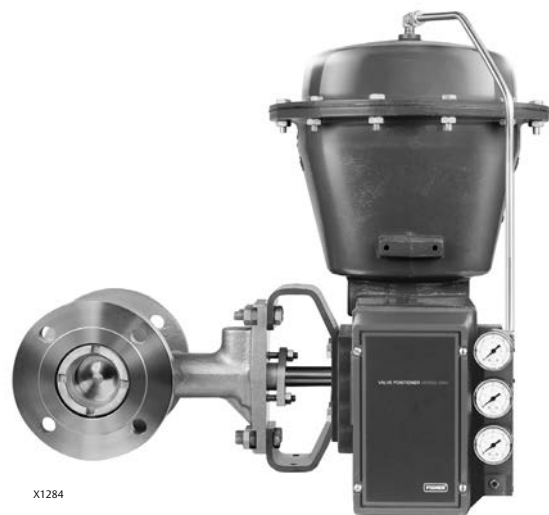

X1284

**3610J PNEUMATIC POSITIONER
WITH 2052 ACTUATOR AND V500 VALVE**

Specifications

Available Configurations

Refer to the type number description on page 6

Input Signal

3610J or 3610JP:

Standard: ■ 0.2 to 1.0 bar (3 to 15 psig), ■ 0.4 to 2.0 bar (6 to 30 psig), or ■ split range, see table 1.

Adjustable: Zero is adjustable from 0.07 to 1.5 bar (1 to 22 psig) for standard valve rotations. Span is adjustable from 0.2 to 2.0 bar (3.2 to 28.8 psi) for standard valve rotations. Location of adjustments are shown in figure 2.

3620J and 3620JP:

4-20 mA DC constant current with 30 VDC maximum compliance voltage. Minimum terminal voltage is 2.4 VDC at 20 mA. Split range is also available, see table 1.

Output Signal

Pneumatic pressure as required by the actuator up to full supply pressure

Action⁽¹⁾: Field-reversible between ■ direct and ■ reverse within the pneumatic positioner

Equivalent Circuit

3620J and 3620JP: 120 ohms shunted by three 5.6 V zener diodes

Typical Performance

Independent Linearity:

Direct-Acting 3610J and 3620J: ±1.5% of output span

Reverse-Acting 3610J and 3620J: ±0.75% of output span

Direct-Acting 3610JP and 3620JP: ±1.25% of output span

Reverse-Acting 3610JP and 3620JP: ±0.5% of output span

Hysteresis:

3610J: 1.0% of output span

3620J: 0.75% of output span

3610JP: 0.5% of output span

3620JP: 0.6% of output span

Deadband: 0.1% of input span

Electromagnetic Compliance for 3622 electro-pneumatic converter:

Meets EN 61326-1:2013

Immunity—Industrial locations per Table 2 of the EN 61326-1 standard. Performance is shown in table 2 below.

Emissions—Class A

ISM equipment rating: Group 1, Class A

Note:The Electromagnetic Compliance specifications also apply to 3620J positioners

Maximum Supply Air Demand⁽²⁾

3610J and 3620J:

1.4 bar (20 psig) Supply: 13 normal m³/hour (490 scfh)

2.4 bar (35 psig) Supply: 17 normal m³/hour (640 scfh)

3610JP and 3620JP:

5.2 bar (75 psig) Supply: 37 normal m³/hour (1380 scfh)

6.9 bar (100 psig) Supply: 46 normal m³/hour (1700 scfh)

Operating Influences

Supply Pressure Sensitivity: A 10% change in supply pressure changes the valve shaft position less than the following percentages of valve rotation:

3610J and 3620J: 1.0% at 1.4 bar (20 psig) supply pressure

3610JP and 3620JP: 1.5% at 4.1 bar (60 psig) supply pressure

Supply Pressure⁽³⁾

Minimum Recommended: 0.3 bar (5 psig) above actuator requirement [1.4 bar (20 psig) for a 0.2 to 1.0 bar (3 to 15 psig) nominal actuator signal; 2.4 bar (35 psig) for a 0.4 to 2.0 bar (6 to 30 psig) nominal actuator signal].

Maximum: 10.3 bar (150 psig) or maximum pressure rating of the actuator, whichever is lower.

Supply Medium: Air or Natural Gas

3620J and 3620JP are not approved for use with natural gas as the supply medium

- continued -

Specifications (continued)

Steady-State Air Consumption⁽²⁾

3610J: 0.40 normal m³/hour (15 scfh) at 1.4 bar (20 psig) supply pressure

3610JP: 0.64 normal m³/hour (24 scfh) at 6.9 bar (100 psig) supply pressure

3620J: 0.49 normal m³/hour (18 scfh) at 1.4 bar (20 psig) supply pressure

3620JP: 0.93 normal m³/hour (35 scfh) at 6.9 bar (100 psig) supply pressure

Operative Temperature Limits⁽³⁾

-40 to 82°C (-40 to 180°F)

Electrical Classification for 3622

Hazardous Area:

CSA— Intrinsicly Safe, Explosion proof, Type n Dust-Ignition proof, Division 2

FM— Intrinsicly Safe, Explosion proof, Type n, Non-incendive, Dust-Ignition proof,

ATEX— Intrinsicly Safe, Type n, Flameproof

IECEX— Intrinsicly Safe, Type n, Flameproof (Gas Atmospheres Only)

Refer to tables 3, 4, 5, and 6 for additional information.

Note: These classifications also apply to 3620J positioners

Housing Classification for 3622

CSA— Type 3 Encl.

FM— NEMA 3, IP54

ATEX— IP64

IECEX— IP54

Mount instrument with vent on side or bottom if weatherproofing is a concern.

Note: These classifications also apply to 3620J positioners

Other Classifications/Certifications for 3622

CUTR— Customs Union Technical Regulations (Russia, Kazakhstan, Belarus, and Armenia)

INMETRO— National Institute of Metrology, Quality and Technology (Brazil)

KGS— Korea Gas Safety Corporation (South Korea)

Contact your [Emerson Process Management sales office](#) for classification/certification specific information



Note: These classifications also apply to 3620J positioners

Hazardous Area Classification for 3610J Positioners

Complies with the requirements of ATEX Group II Category 2 Gas and Dust

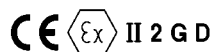

Meets Customs Union technical regulation TP TC 012/2011 for Groups II/III Category 2 equipment

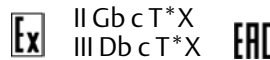

Note: These ratings do *not* apply to 3620J positioners

Construction Materials

All Positioners:

Case: Low copper aluminum alloy

Cover: Polyester plastic

Feedback Lever: Stainless steel

Range Spring: Zinc-plated steel

Input Module and Relay Diaphragms: Nitrile and polyester

Relay Valve Plugs and Seats: Stainless steel

Tubing: Copper (standard)

Fittings: Brass (standard)

Gauges: Chrome-plated brass connection with plastic case

3620J and 3620JP:

Housing and Cap: Low copper aluminum alloy

Pressure Connections

1/4 NPT internal

- continued -

Specifications (continued)

<p>Rotary Valve Rotation</p> <p>60, 75, or 90 degrees</p> <p>Characterized Cams</p> <p>See Characterized Cams section</p> <p>Electrical Connection for 3620J and 3620JP</p> <p>1/2-14 NPT Conduit Connection</p>	<p>Options</p> <p>3610J and 3610JP:</p> <ul style="list-style-type: none"> ■ Supply pressure gauge, ■ tire valves, or ■ plugs, ■ Integral mounted bypass valve on 3610J only <p>3620J and 3620JP:</p> <ul style="list-style-type: none"> ■ Supply pressure gauge, ■ tire valves, or ■ plugs <p>Approximate Weight</p> <p>3610J positioners: 2.5 kg (5.6 pounds) 3620J positioners: 3.6 kg (8.0 pounds)</p>
---	---

NOTE: Specialized instrument terms are defined in ANSI/ISA Standard 51.1 - Process Instrument Terminology.
 1. For direct action, an increasing input signal extends the actuator rod. For reverse action, an increasing input signal retracts the actuator rod.
 2. Normal m³/hr--normal cubic meters per hour (0°C and 1.01325 bar absolute). Scfh--standard cubic feet per hour (60°F and 14.7 psia).
 3. The pressure and temperature limits in this document and any applicable standard or code limitation should not be exceeded.

Table 1. Split-Range Capabilities

3610J AND 3610JP POSITIONERS⁽¹⁾				
Split	0.2 to 1.0 Bar (3 to 15 Psig) Input Signal		0.4 to 2.0 Bar (6 to 30 Psig) Input Signal	
	Bar	Psig	Bar	Psig
Two-way	0.2 to 0.6 0.6 to 1.0	3 to 9 9 to 15	0.4 to 1.2 1.2 to 2.0	6 to 18 18 to 30
Three-way	0.2 to 0.5 0.5 to 0.7 0.7 to 1.0	3 to 7 7 to 11 11 to 15	0.4 to 0.9 0.9 to 1.5 1.5 to 2.0	6 to 14 14 to 22 22 to 30
3620J AND 3620JP POSITIONERS⁽¹⁾				
Split	4-20 Milliampere Input Signal			
Two-way	4 to 12 12 to 20			
Three-way	4 to 9.3 9.3 to 14.7 14.7 to 20			

1. This table is only valid for the following standard valve rotations/range spring combinations: 90°/18A7845X012 (blue), 75°/18A7846X012 (yellow), and 60°/18A5118X012 (red). Contact your [Emerson Process Management sales office](#) or the factory for input signal ranges not listed.

Table 2. Fisher 3622 Electro-Pneumatic Converter⁽¹⁾ EMC Summary Results—Immunity

Port	Phenomenon	Basic Standard	Test Level	Performance Criteria ⁽²⁾
Enclosure	Electrostatic Discharge (ESD)	IEC 61000-4-2	4 kV contact; 8 kV air	A
	Radiated EM field	IEC 61000-4-3	80 to 1000 MHz @ 10V/m with 1 kHz AM at 80% 1400 to 2000 MHz @ 3V/m with 1 kHz AM at 80% 2000 to 2700 MHz @ 1V/m with 1 kHz AM at 80%	A
	Rated power frequency magnetic field	IEC 61000-4-8	60 A/m at 50 Hz	A
I/O signal/control	Burst (fast transients)	IEC 61000-4-4	1 kV	A
	Surge	IEC 61000-4-5	1 kV (line to ground only, each)	B
	Conducted RF	IEC 61000-4-6	150 kHz to 80 MHz at 3 Vrms	A

Specification limit = ±1% of span
 1. The information contained in the table also applies to 3620J, 3620JP, and 3621JP electro-pneumatic positioners.
 2. A=No degradation during testing. B = Temporary degradation during testing, but is self-recovering.

Figure 1. Typical Fisher 3610J and 3620J Positioner Mounting

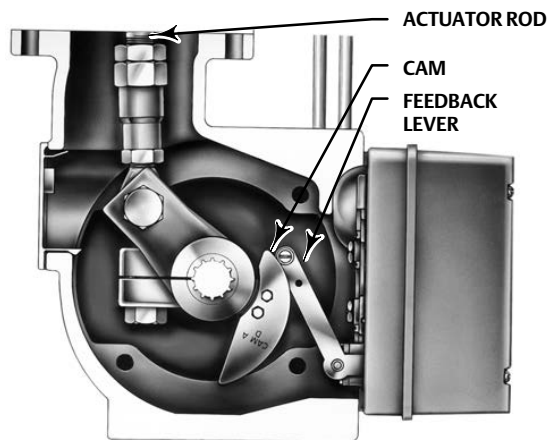

W3783

Figure 2. Adjustments for Fisher 3610J and 3620J Positioners

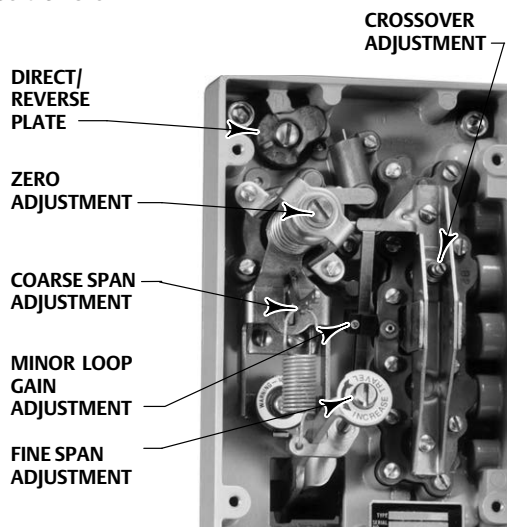

W4900-1

Features

- **Accurate, Efficient, Vibration-Resistant Operation**—The positioner provides accurate, fast-response and can withstand the vibrations of most plant environments. Low steady-state air consumption contributes to efficient operation.
- **Modular Design**—The pneumatic 3610J positioner easily converts to an electro-pneumatic 3620J positioner by replacing the existing gauge block with the 3622 electro-pneumatic converter assembly. The converter assembly attaches to the existing positioner, providing a simple, compact, and cost-effective conversion.
- **Versatility**—3610J and 3610JP positioners accept a pneumatic input signal and 3620J and 3620JP positioners accept a DC current input signal from a control device. The pneumatic and electro-pneumatic positioners provide split range capabilities and adjustable zero and span. The rangeability of the positioner zero and span permits using a single range spring for all standard input signals including split ranges.
- **Fewer Spare Parts**—Most of the parts for 3610J and 3610JP or 3620J and 3620JP positioners are interchangeable, requiring fewer spare parts to support these positioners.
- **Easy Positioner Adjustments**—With the cover removed, zero, span, and cross-over adjustments, shown in figure 2, are easily accessible and can be made with a screwdriver.
- **Application Flexibility**—Easily adjustable minor loop gain fine tunes the positioner to optimize dynamic response for each specific actuator size and application.
- **Stable Operation**—Changes in supply pressure have minimal effect on positioner operation.
- **Corrosion Resistant**—Case, components, and gasket materials withstand harsh environments. Positioner bleed air purges internal parts and actuator housing for additional protection.
- **Field Reversible**—Simple adjustments permit switching between direct and reverse action; no additional parts are required.

Figure 3. Schematic of Fisher 3610JP Positioner

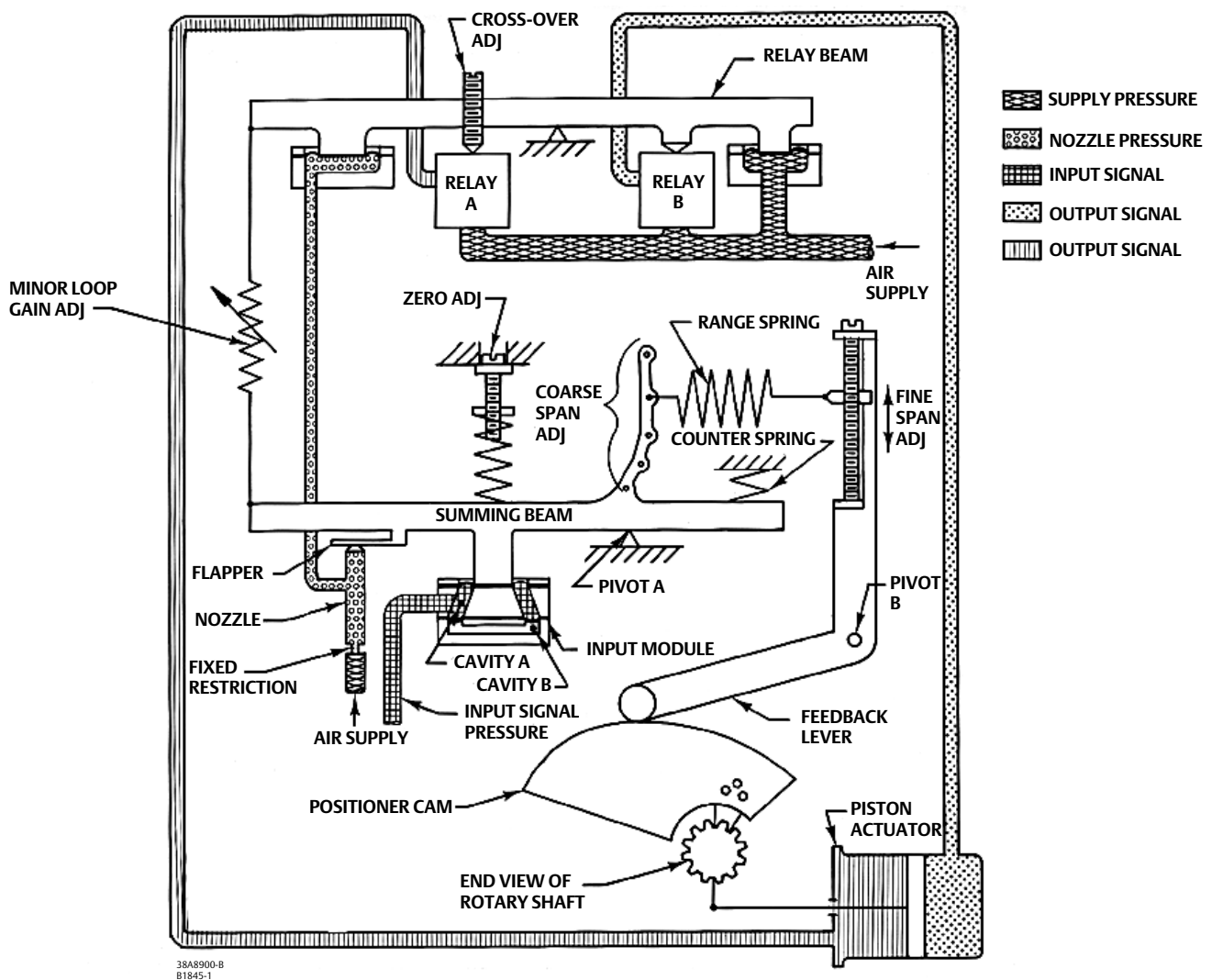

Type Number Description

The following descriptions provide specific information on the different positioner constructions.

3610J: A single-acting pneumatic rotary valve positioner for use with Fisher 1051 and 1052 actuators.

3610JP: A double-acting pneumatic rotary valve positioner for use with Fisher 1061 and 1069 actuators.

3620J: A single-acting electro-pneumatic rotary valve positioner for use with 1051 and 1052 actuators.

3620JP: A double-acting electro-pneumatic rotary valve positioner for use with 1061 and 1069 actuators.

3622: An electro-pneumatic converter that converts a 4-20 mA DC input signal to a 3 to 15 psig (0.2 to 1.0 bar) input signal for the pneumatic positioner. Combining this unit with a 3610J or 3610JP positioner produces a 3620J or 3620JP positioner, respectively.

Principle of Operation

3610J positioners accept a pneumatic input signal and 3620J positioners accept a DC current input signal from a control device.

Figure 4. Schematic of Fisher 3620JP Positioner

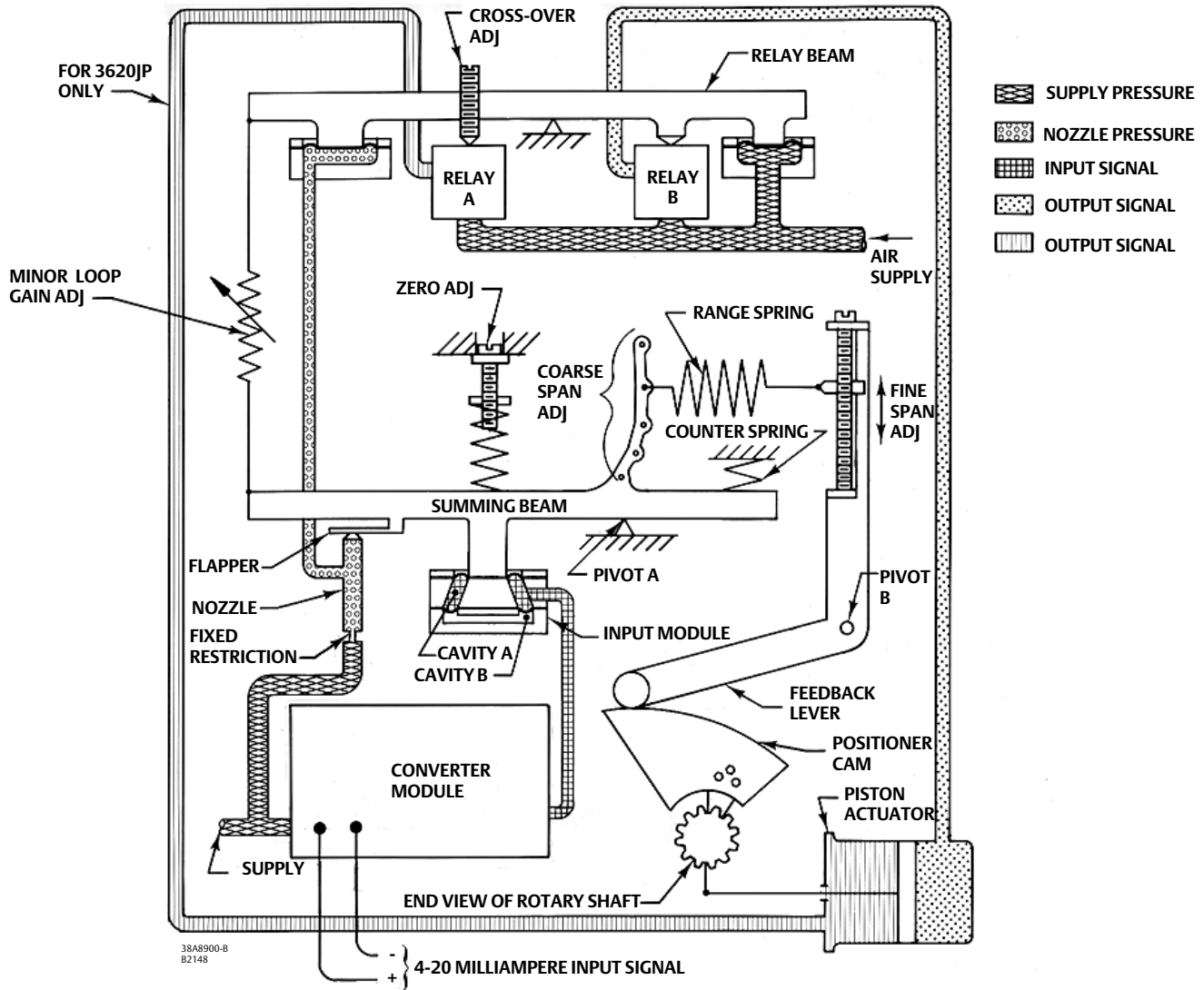

These positioners are force-balanced instruments that provide a valve shaft position proportional to the input signal. The following describes the principle of operation for 3610JP and 3620JP positioners. The principle of operation for 3610J and 3620J positioners is similar except relay A is not used. Refer to figures 3 and 4 while reading the following descriptions.

For direct action, input signal pressure from a control device is channeled to cavity A in the input module. An increase in input signal pressure results in a downward force on the summing beam, pivoting the

summing beam counterclockwise. This moves the flapper slightly toward the nozzle, increasing the nozzle pressure. As nozzle pressure increases, the relay beam pivots clockwise, causing relay B to increase upper cylinder pressure and relay A to exhaust lower cylinder pressure of the actuator.

As a result, the actuator rod extends and the actuator rotary shaft rotates clockwise. This causes the feedback lever to pivot clockwise and the force applied to the summing beam by the range spring increases. This force, which opposes the downward force on the summing beam caused by the increasing input signal

pressure, continues to increase until the summing beam torques are in equilibrium. At this point, the valve shaft is in the correct position for the specific input signal applied.

For reverse action, input signal pressure is channeled to both cavities A and B. An increase in signal pressure results in an upward force on the summing beam, pivoting the summing beam clockwise and causing relay B to exhaust upper actuator cylinder pressure to atmosphere and relay A to increase lower actuator cylinder pressure. As a result, the actuator rod retracts and the actuator rotary shaft rotates counterclockwise. This causes the feedback arm to pivot counterclockwise reducing the force applied to the summing beam by the range spring.

As the valve shaft rotates counterclockwise, the range spring force to the summing beam continues to reduce until the summing beam torques are in equilibrium. At this point, the valve shaft is in the correct position for the specific input signal applied.

3620J or 3620JP positioners (figure 4) are a combination of a 3610J or a 3610JP positioner with a 3622 electro-pneumatic converter. The electro-pneumatic converter provides a 0.2 to 1.0 bar (3 to 15 psig) output pressure proportional to the

4-20 mA DC input signal. The 0.2 to 1.0 bar (3 to 15 psig) output pressure becomes the input signal pressure to the 3610J or 3610JP pneumatic positioner.

Installation

The supply pressure medium must be a clean, dry, and oil-free air, or noncorrosive gas (3610J positioners only). If the supply pressure source is capable of exceeding the maximum actuator operating pressure or positioner supply pressure, appropriate steps must be taken during installation to protect the positioner and all connected equipment against overpressure.

Typical positioner mounting on an actuator is shown on the front page. Overall dimensions are shown in figure 5.

Note

3620J and 3620JP positioners are not approved for use with natural gas as the supply medium.

Figure 5. Typical Mounting Dimensions and Connections

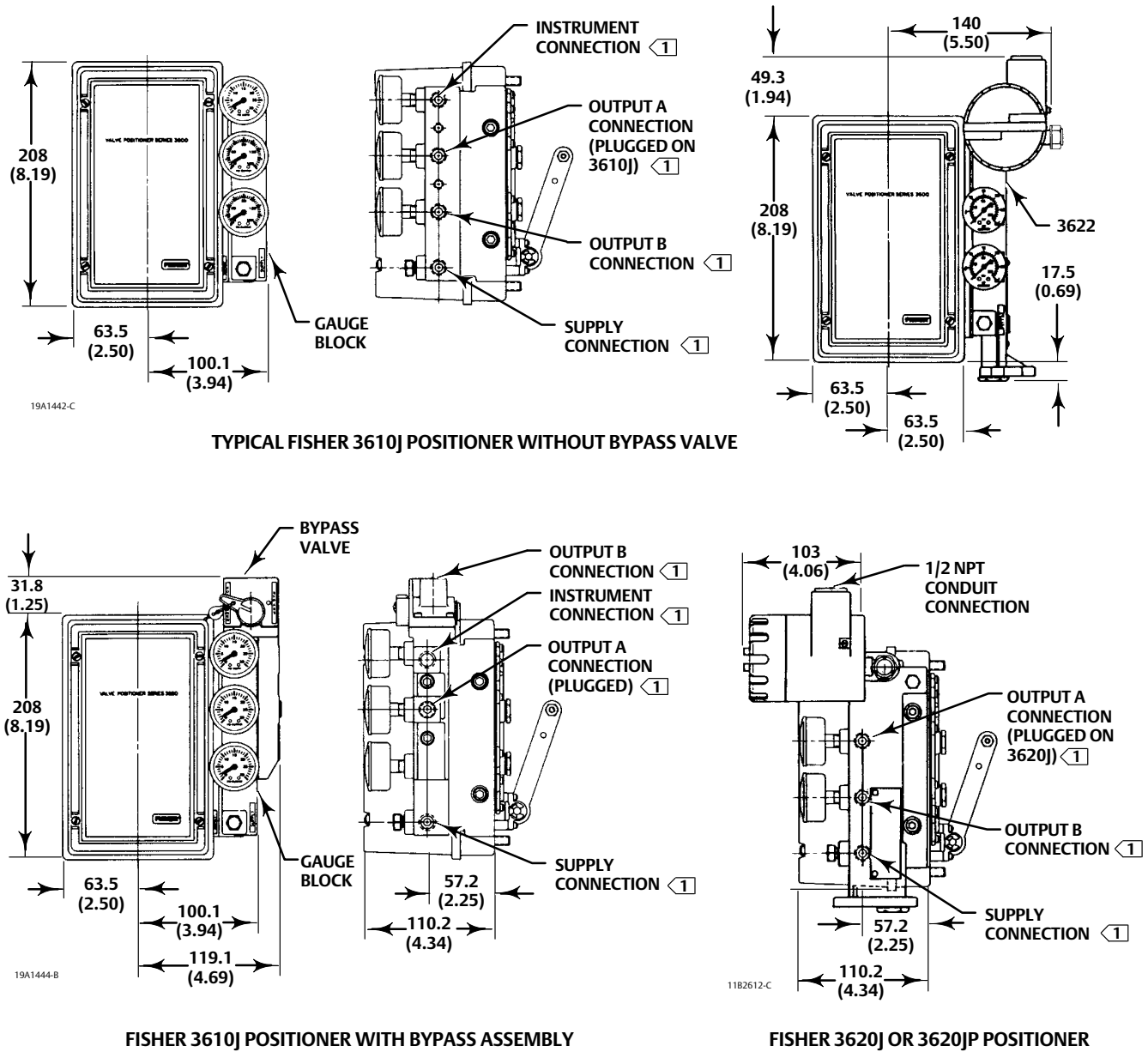

mm
(INCH)

Note:
 Instrument, Output, and Supply connections are 1/4 NPT.

C0681-2

Figure 6. Input Span Versus Valve Rotation

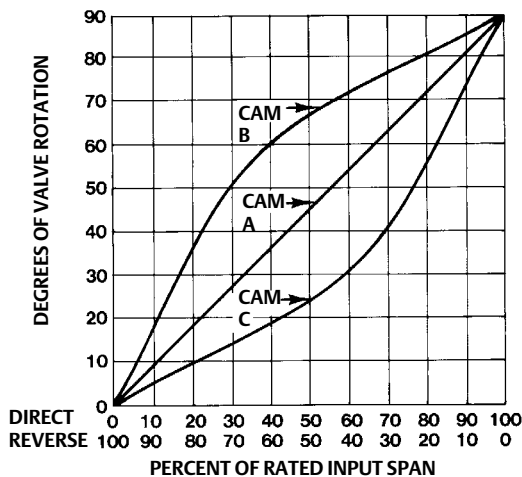

A2264-1

Figure 7. Flow Characteristics for the Various Cams When Used with an Equal Percentage Characteristic, Push-Down-to-Close Valve

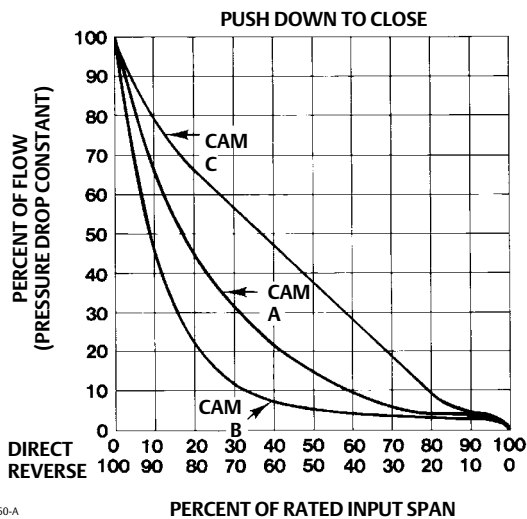

33A4960-A
A1582-2

Characterized Cams

3610J and 3620J positioners are available with any one of three cams, a linear cam (cam A) or two characterized cams (cams B and C). Figure 6 shows the resultant valve rotation due to an incremental instrument pressure change for the three cams.

Figures 7 and 8 show how the flow characteristics change when using the cams with a valve that has equal percentage characteristics.

Figure 8. Flow Characteristics for the Various Cams When Used with an Equal Percentage Characteristic, Push-Down-to-Open Valve

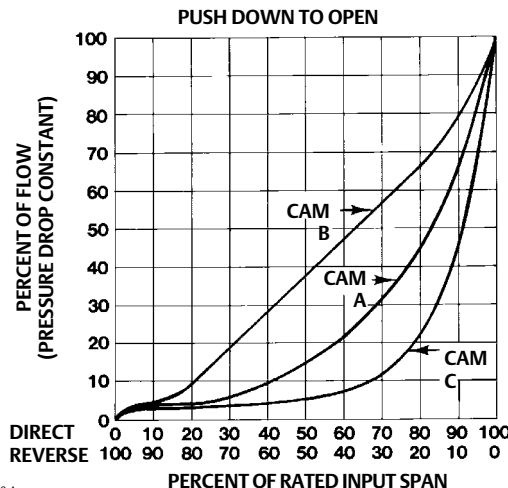

33A4959-A
A1581-2

When the linear cam is the operating cam, there is a linear relationship between an incremental instrument pressure change and the resultant valve stem rotation. The flow characteristic is that of the control valve.

As shown in figure 6, installing either characterized cam as the operating cam changes the relationship between the incremental instrument pressure change and valve stem travel, thereby modifying the valve flow characteristics.

Ordering Information

When ordering, specify the product application and construction:

Application

1. Positioner type number
2. Maximum supply pressure available
3. Actuator size and type number
4. Cam characteristic
5. Input signal

Construction

Refer to the specifications. Carefully review each specification; indicate your choice whenever a selection is to be made.

Table 3. Hazardous Area Classifications for Fisher 3622 Electro-Pneumatic Converter⁽¹⁾—CSA (Canada)

Certification Body	Certification Obtained	Entity Rating	Temperature Code
CSA	Intrinsically Safe Ex ia IIC T4/T5/T6 per drawing GE28591 Ex ia Intrinsically Safe Class I, II Division 1 GP A,B,C,D,E,F,G T4/T5/T6 per drawing GE28591	Vmax = 30 VDC Imax = 150 mA Pi = 1.25 W Ci = 0 nF Li = 0 mH	T4 (Tamb ≤ 82°C) T5 (Tamb ≤ 62°C) T6 (Tamb ≤ 47°C)
	Explosion-proof Ex d IIC T5 Class I, Division 1, GP A,B,C,D T5	---	T5 (Tamb ≤ 82°C)
	Type n Ex nA IIC T6	---	T6 (Tamb ≤ 82°C)
	Class I, Division 2, GP A,B,C,D T6		T6 (Tamb ≤ 82°C)
	Class II, Division 1, GP E,F,G T5	---	T5 (Tamb ≤ 82°C)
	Class II, Division 2, GP F,G T6		T6 (Tamb ≤ 82°C)

1. These hazardous area classification also apply to 3620J positioners.

Table 4. Hazardous Area Classifications for Fisher 3622 Electro-Pneumatic Converter⁽¹⁾—FM (United States)

Certification Body	Certification Obtained	Entity Rating	Temperature Code
FM	Intrinsically Safe Class I Zone 0 AEx ia IIC T4/T5/T6 per drawing GE28590 Class I, II, III Division 1 GP A,B,C,D,E,F,G T4/T5/T6 per drawing GE28590	Vmax = 30 VDC Imax = 150 mA Pi = 1.25 W Ci = 0 nF Li = 0 mH	T4 (Tamb ≤ 82°C) T5 (Tamb ≤ 62°C) T6 (Tamb ≤ 47°C)
	Explosion-proof Class I Zone 1 AEx d IIC T5 Class I, Division I, GP A,B,C,D T5	---	T5 (Tamb ≤ 82°C)
	Type n Class I Zone 2 AEx nA IIC T5	---	T5 (Tamb ≤ 82°C)
	Class I, Division 2, GP A,B,C,D T5 Class II, Division 1, GP E,F,G T5 Class II, Division 2, GP F,G T5	---	T5 (Tamb ≤ 82°C)

1. These hazardous area classification also apply to 3620J positioners.

Table 5. Hazardous Area Classifications for Fisher 3622 Electro-Pneumatic Converter⁽¹⁾—ATEX

Certificate	Certification Obtained	Entity Rating	Temperature Code
ATEX	⊕ II 1 G & D		
	Intrinsically Safe Gas Ex ia IIC T4/T5/T6 Ga	Ui = 30 VDC Ii = 150 mA Pi = 1.25 W Ci = 0 nF Li = 0 mH	T4 (Tamb ≤ 82°C) T5 (Tamb ≤ 62°C) T6 (Tamb ≤ 47°C)
	Dust Ex ia IIIC Da T120°C (Tamb ≤ 82°C) / T100°C (Tamb ≤ 62°C) / T85°C (Tamb ≤ 47°C)		---
	⊕ II 2 G & D		
	Flameproof Gas Ex d IIC T5 Gb	---	T5 (Tamb ≤ 82°C)
	Dust Ex tb IIIC Db T82°C (Tamb ≤ 79°C)		---
	⊕ II 3 G & D		
	Type n Gas Ex nA IIC T6 Gc	---	T6 (Tamb ≤ 82°C)
Dust Ex tc IIIC Dc T85°C (Tamb ≤ 82°C)		---	

1. These hazardous area classification also apply to 3620J positioners.

Table 6. Hazardous Area Classifications for Fisher 3622 Electro-Pneumatic Converter⁽¹⁾—IECEX

Certificate	Certification Obtained	Entity Rating	Temperature Code
IECEX	Intrinsically Safe Gas Ex ia IIC T4/T5/T6 Ga	U _i = 30 VDC I _i = 150 mA P _i = 1.25 W C _i = 0 nF L _i = 0 mH	T4 (T _{amb} ≤ 82°C) T5 (T _{amb} ≤ 62°C) T6 (T _{amb} ≤ 47°C)
	Flameproof Gas Ex d IIC T5 Gb	---	T5 (T _{amb} ≤ 82°C)
	Type n Gas Ex nA IIC T6 Gc	---	T6 (T _{amb} ≤ 82°C)
1. These hazardous area classification also apply to 3620J positioners.			

Neither Emerson, Emerson Process Management, nor any of their affiliated entities assumes responsibility for the selection, use or maintenance of any product. Responsibility for proper selection, use, and maintenance of any product remains solely with the purchaser and end user.

Fisher is a mark owned by one of the companies in the Emerson Process Management business unit of Emerson Electric Co. Emerson Process Management, Emerson, and the Emerson logo are trademarks and service marks of Emerson Electric Co. All other marks are the property of their respective owners.

The contents of this publication are presented for informational purposes only, and while every effort has been made to ensure their accuracy, they are not to be construed as warranties or guarantees, express or implied, regarding the products or services described herein or their use or applicability. All sales are governed by our terms and conditions, which are available upon request. We reserve the right to modify or improve the designs or specifications of such products at any time without notice.

Emerson Process Management
Marshalltown, Iowa 50158 USA
Sorocaba, 18087 Brazil
Cernay, 68700 France
Dubai, United Arab Emirates
Singapore 128461 Singapore

www.Fisher.com

