

## YORK<sup>®</sup> Industrial Control Center Retrofit

Offer for:

DuPont  
Wilmington, DE  
Original Sales Order: 90-813634

## Executive Summary

The existing controls for the process chillers/compressors are original equipment and offer the following challenges:

- Existing controls pose a major challenge for plant personnel in trouble shooting unit operational issues
- Little or no OEM technical support available to trouble shoot or modify existing system
- Control components are out of date with a number of components being obsolete with no direct replacement parts available
- Service support is increasingly difficult to provide as trained personnel with necessary programming software have become extremely rare throughout the nation. Although JCI strives to service the existing control panels in a timely manner, we face this difficult reality and will not be able to ensure the same level of prompt technical and parts support for these obsolete panels that have been provided in the past.
- Original automatic functionality of the capacity controls have been abandoned leading to inefficient operation and compromised system safety protection
- Existing controls yield inefficient low load operation
- Current control strategy provides little protection from compressor surging at reduced loads
- Other than high current safety shut down, existing controls do not provide automatic current limit protection for motor to enable automatic high load operation
- Other than the high pressure safety shut down, existing controls do not provide provisions to ensure continued unit operation under high discharge pressure conditions
- Other than the low pressure safety shut down, existing controls do not provide provisions to ensure continued unit operation under low suction pressure conditions

Johnson Controls continues to lead the industry in chiller/compressor electronics which includes the YORK® Industrial Control Retrofit, a custom PAC (Programmable Automation Controller) control panel with graphic display. It is the standard offering on the YORK® Titan Industrial chiller and is offered as an aftermarket upgrade for other industrial applications such as this. Every control panel retrofit receives full JCI/York factory engineering support to ensure a proper application. JCI/York factory and local service support ensures efficient and reliable operation for years to come. Documentation and training will be provided to ensure customer's understanding of proper operation and troubleshooting capabilities. This project will bring the controls up to date, providing the following solutions to existing challenges:

- Eliminate obsolescence associated with existing control system
- Increase the equipments overall reliability with current state of the art technology
- Provide for automatic energy efficient operation
- Provide increased protection against compressor surging
- Provide for more efficient part load operation
- Provide additional safety protection
- Provide useful data to allow for more timely troubleshooting of unit operational issues
- Provide for data logging which will allow for operators to trend unit operation and implement corrective measures in a more timely manner

- Provide automatic current limit control at high load to ensure continued stable operation
- Provide automatic capacity limit control at high discharge pressure conditions to ensure continued stable operation
- Provide automatic capacity limit control at low suction pressure conditions to ensure continued stable operation
- Provide interface capability with existing DCS to keep operators better informed of system operation and allow for more timely adjustments to operating setpoints

## Overview

The **YORK**<sup>®</sup> Industrial Control Retrofit is based on an Allen-Bradley Logix5000 programmable automation controller (PAC) and a RedLion HMI color graphics display with a membrane keypad for operator interface. The control panel and field installed electro-pneumatic devices provide all necessary controls and control logic to provide manual operation, automatic operation, pneumatic capacity control and safety protection of the chiller/compressor unit. Chiller control algorithms, graphics, and software remain the intellectual property of Johnson Controls.

JCI shall retain all right, title, ownership and interest in and to any (a) deliverables provided to the customer hereunder, including without limitation, all software source and object code, documentation, technical information or data, specifications and designs and any changes, improvements or modifications thereto or derivatives thereof ("Deliverables") and (b) Know-How (defined below) employed by JCI in the creation of the Deliverables or performance of the Services, whether known to JCI prior to, or developed or discovered or acquired in connection with, the performance of its obligations hereunder. Ownership of all Deliverables and Know-How shall vest solely in JCI and no Deliverables shall be deemed "works made for hire." Without limiting the generality of the foregoing, ownership of all source files used in the course of performing the Services shall remain the exclusive property of JCI. For purposes of this Agreement, "Know-How" means any know-how, processes, techniques, concepts, methodologies, tools, analytical approaches, database models and designs, discoveries, and ideas furnished, produced by, developed, employed or used by JCI in the creation or provision of the Deliverables or in the performance of the Services, and any changes, improvements or modifications thereto or derivatives thereof. Under no circumstances shall the customer obtain access or ownership to any JCI proprietary information, including, but not limited to, source codes, object codes, specifications and designs.

Alarm annunciation is provided by alarm indicators on the color graphic screens. An alarm history screen is provided which shows the most recent alarms with the time and date of occurrence. Trip status screens are provided which show the values of analog inputs at the time of the last five chiller safety shutdowns. The time and date of the shutdown are also recorded and shown.

The architecture of the **YORK**<sup>®</sup> Industrial Control Retrofit combines industry standard system components that easily integrate with all aspects of the chiller system.

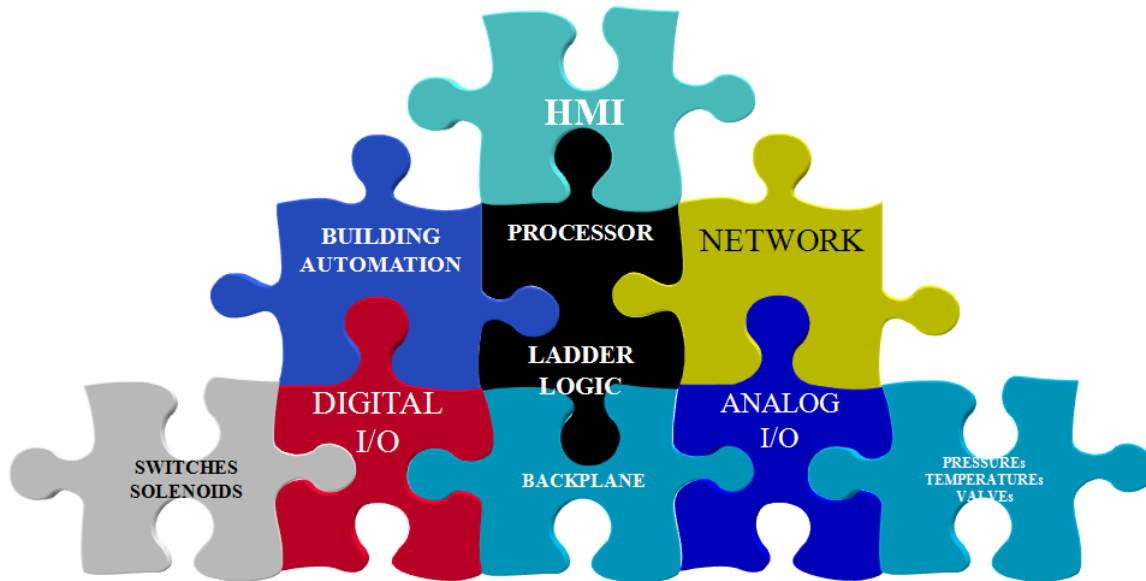

The **YORK**<sup>®</sup> Industrial Control Retrofit offers the following benefits:

- Dynamic Capacity Control
- Adapts to the demands of ever changing chilling conditions
- Advanced Anti-surge Algorithms
- Improved chiller/compressor efficiency
- Protects the investment of an Industrial Chiller

## Deliverables

### Hardware

- **YORK**® Industrial Control Retrofit Panel
- Drawings
  - Elementary Diagram
  - Panel Layout and Bill of Materials
  - Instrument kit Bill of Materials
- Backup copies of the chiller control ladder “LOGIX.ZIP” file will be provided after commissioning is complete.
- Backup copies of the chiller HMI application “image.ci3” file will be provided after commissioning is complete.
- Operation Manual in PDF format
  
- Instrument Kit By YORK

### Installation

- Lock-out-Tag-out of all utilities to provide safe work environment
- Removal and storage of refrigerant as necessary per current EPA Rules and Regulations
- Removal and disposal of all existing control components not being re-used
- Expansion or replacement of housekeeping pad to accommodate new control panel
- Installation of new control panel
- Installation of new end-devices. All new end-devices will be installed at point of measurement/control to minimize refrigerant piping.
- Installation of all control and power wiring.
  - All 120 volt and greater wiring will be run in conduit equivalent to existing installation.
  - For all NEMA-1 environments, all 24 voltage wiring will be run in open bundling and/or wire trays.
- Installation and tuning of control programming
- System start-up and concurrent operator training

[Click here to enter text.](#)

Customer is responsible for the following:

- Removal and disposal of hazardous material (i.e. asbestos, mercury, etc.)
- 120 volt power supply to panel if existing supply is not adequate
- Starter compliance with YORK starter specification R-787 for electric drive units.

## YORK® Industrial Control Retrofit Panel

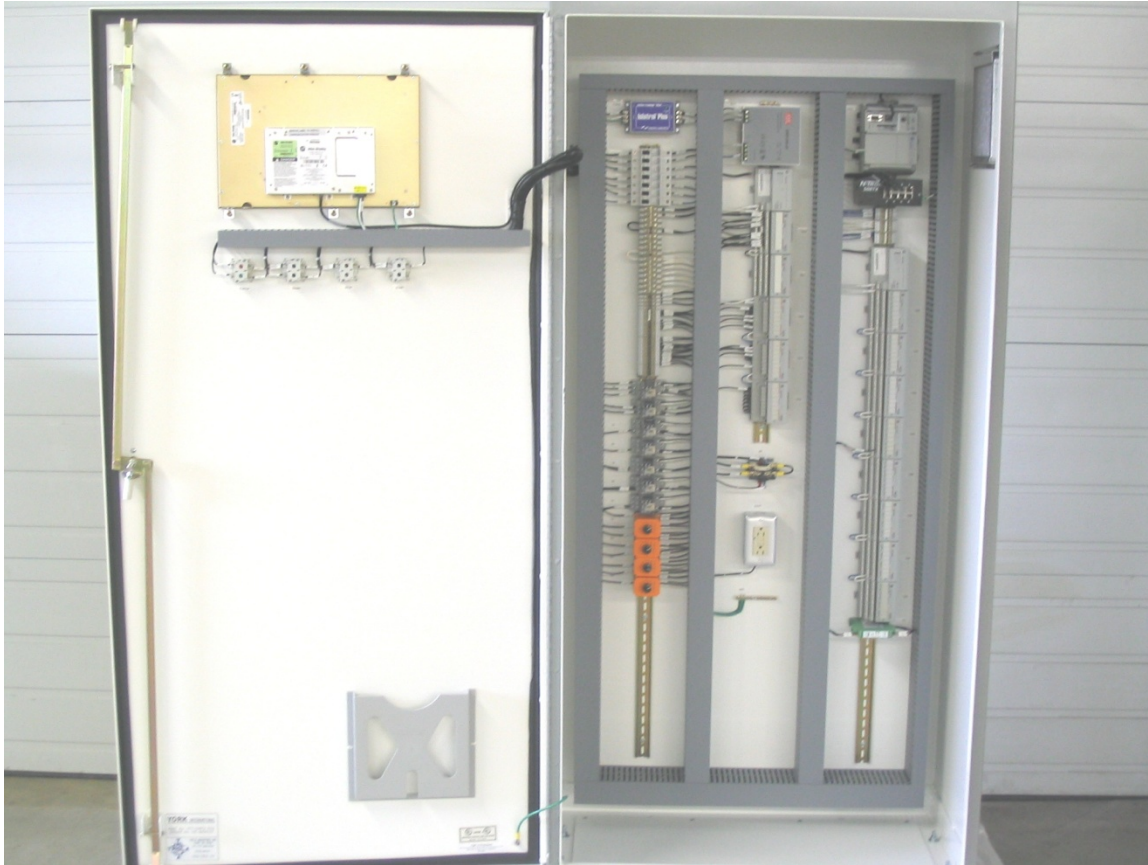

Typical configuration. Actual panel layout may vary.

All controls are arranged for easy access. Wiring is color coded black (120VAC control circuits), white (neutral), and green (ground). Wiring enclosed in shielded cables is color coded per the wiring diagram. External (field) wiring connections are made to clearly marked terminal strips and the Allen-Bradley Flex I/O terminal blocks. Flexibility is provided to allow for choosing locations and size of the conduit connections at time of installation. Control voltage internal panel wiring is done with MTW 18 AWG wire minimum. The panel will require a 50 amp 120 volt 60 Hertz power supply from either a 5.0 KVA transformer in the motor control center (MCC) or from a separate source. This power is for the oil heaters and control components.

The pneumatic controls, including valves and ancillary equipment require:

Electric drive units require 4-6 SCFM of clean dry filtered instrument air at 80 to 100 psig pressure.

Type Z purge units, for air purge applications, will add 1-3 SCFM depending on enclosure size.

The control panel contains all necessary controls and control logic to provide stand-alone operation including the following:

- Electric Drive
- Automatic Startup
- Fail-safe fully automatic operation of compressor, motor and speed increaser
- PID capacity control
- Safety protection of the compressor, speed increaser, electric motor, cooler and condenser.
- Automatic pre-lube and post-lube operation of the speed increaser gear and compressor auxiliary oil pumps (AOP)
- Operation of the Auxiliary Oil Pumps during any low pressure lube condition.
- Automatic control of compressor capacity to limit maximum motor power consumption, manually adjustable 100 to 40% of chiller capacity.
- Safety and Protection of the Compressor, Gearbox, and Motor
- Energy efficient integration of vane control and hot gas control to protect compressor from surge.
- Automatic operation of Interstage Valve(s)

All temperature and pressure displays are in English (+/- PSIG, °F, GPM) units of measure. All points are electronically monitored from locally mounted RTDs with transmitters and pressure transducers.

The control console is factory (internally) wired in an upright front panel display style, Nema 12. The panel is fabricated of 10-gauge Steel and includes a full height front access door. The panel enclosure is painted ANSI light gray. A separate, hardwired condenser refrigerant high-pressure cutout switch, remotely mounted at the compressor, is provided in accordance with ANSI/ASHRAE Standard 15 Safety Code requirements.

The following operator interface is provided on front of control panel

- Start Pushbutton
- Stop Pushbutton
- System Reset Pushbutton
- Hard Wired Emergency Stop Pushbutton bypassing all controls
- Front Panel display for Operator Interface to all other functions that are software operated.

The INPUT/OUTPUT System utilizes the Allen-Bradley Flex I/O system for its expandability, versatility, reliability, and low cost. The architecture allows for multiple racks and distributed I/O.

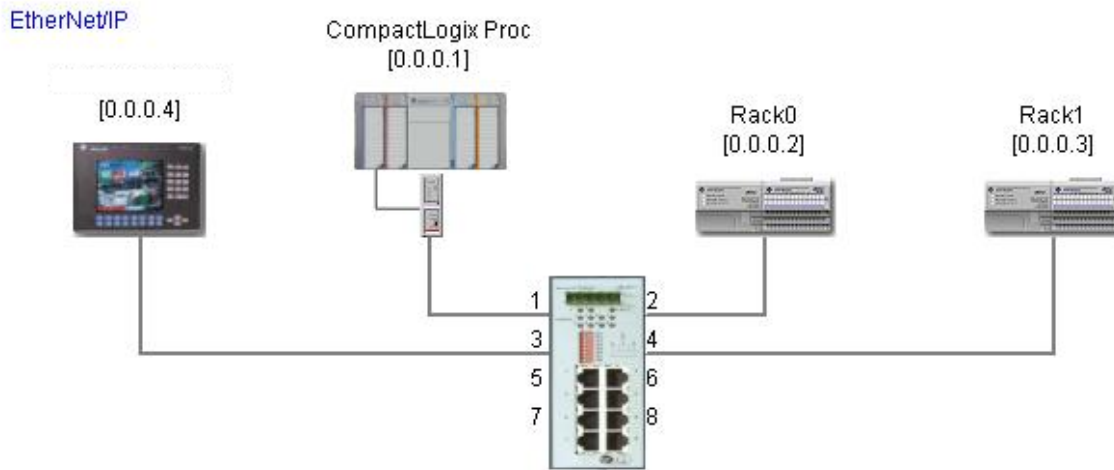

The RedLion LCD display features graphic animated display of the chiller, chiller subsystems and system parameters, allowing the presentation of several operating parameters at once.

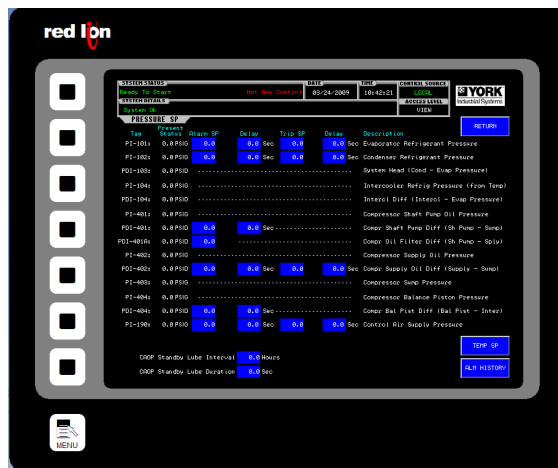

During startup, operation and shutdown, the system will display vital information available at any time. The locations of various chiller parameters are clearly marked and instructions for specific operation are provided on many of the screens.



The color graphic display can be accessed remotely over a LAN connection using a simple web browser. The remote virtual HMI in the web browser is exactly the same as standing in

front of the control panel, without leaving the control room. Preferred HMI models have two LAN ports, one which is dedicated to remote virtual HMI, and remote IP networking.

The main status indicator bar at the top of the screen will display the SYSTEM STATUS with the following example messages:

<b>READY TO START</b>	Unit is ready to start in Local Mode
<b>REMOTE START ENABLED</b>	Unit is ready to start in Remote Mode
<b>START / PRELUBE = XXX sec</b>	Locally initiated start / Prelube cycle
<b>REM START / PRELUBE = XXX sec</b>	Remote initiated start / Prelube cycle
<b>SYSTEM RUNNING</b>	System Running
<b>SYSTEM COASTDOWN = XXX sec</b>	System stopping / Post lube cycle
<b>SYSTEM TRIPPED</b>	System Tripped Offline
<b>ANTI-RECYCLE = XX:XX</b>	<b>Anti-recycle Countdown</b>
<b>Controlled Stop</b>	Control Stop initiated
<b>Remote Lockout</b>	Remote mode selected / not confirmed

The following are typical panel display indicators:

- On (engaged) and Off (disengaged) signals are represented by “LED” symbols. A red LED symbol is ON , and a grey LED symbol is OFF .
- Running Pumps are shown as RED, and pumps not running are shown as GREEN.
- Pre-Trip Alarm (Yellow Blinking “**A**”) and Trip (Red Blinking “**T**”) indicators (other than described above) appear adjacent to the descriptive text of the measurement parameter whenever applicable.
- The measurement parameter text (**PSIG**, **°F**) changes to YELLOW blinking if the analog input signal goes out of range and will remain in this state until the RESET pushbutton is pushed after the input signal returns to normal
- The Pre-Trip Alarm indicator will automatically be reset if the abnormal condition progresses to a point below the alarm setpoint.
- The Trip Alarm indicator will remain in the alarm state until the RESET pushbutton is pressed after the conditions have returned to normal.

Graphical animated screens provide a means of data display and service for various system components. Screens indicate all aspects of operation and sensor data pertaining to the particular component depicted.

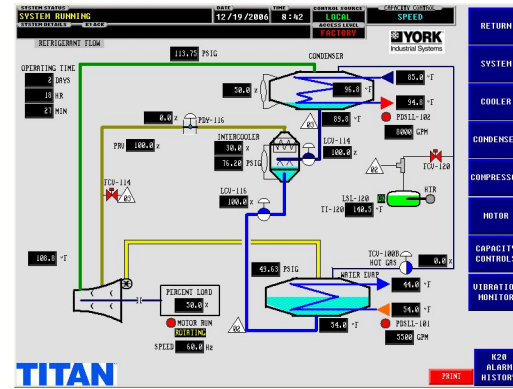
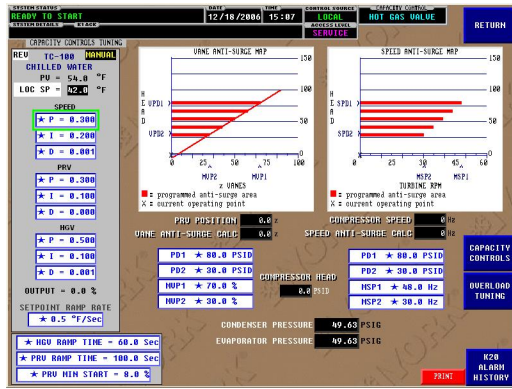
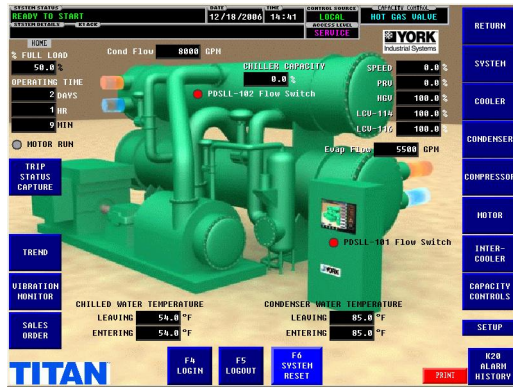
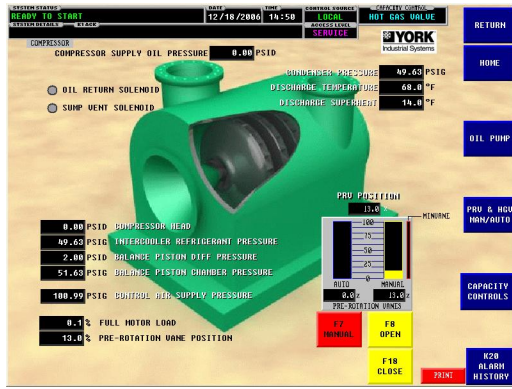

Typical screens. Actual screens may vary with application.

At the top of each main screen is displayed the system status, present date and time, local or remote control source and system access level. Sub-screens may also be available for some system components providing additional data access. Screens are selected by selecting the appropriate tabs on the sides of the display and pressing the soft touch screen button corresponding to a particular screen tab.

## Capacity Controls System

The Capacity Controls of the **YORK**<sup>®</sup> Industrial Control Retrofit allow efficient fully automated control, without need for operator intervention. This control system also monitors and displays all safety aspects of the chiller and provides alarms and a shutdown if safety limits are exceeded.

The Capacity Controls algorithm automatically seeks out the most efficient operation of the Titan chiller. The pre-rotation vanes are automated to meet the desired system control parameters. To provide light duty operation, the hot gas recycle valve is seamlessly throttled open according to system process demands. This keeps the centrifugal compressor out of surge and maintains chilled process production.

With an electric motor drive unit, in cases of high load which exceeds the motor power usage, the capacity controls algorithm automatically unloads the system to maintain a restriction on power consumption.

With Fixed Speed operation the minimum vane opening is used with the minimal amount of hot gas.

In the situation of high discharge pressure or low suction pressure override the dynamic overrides act on the capacity controls in the interests of keeping the chiller system online at a part load point. The system will modulate back to full load when the pressures return to conditions within the design range.

If operator intervention is required, manual controls are provided on the Electronic Operator interface for all I/P converters and auxiliary oil pumps.

## Chiller Plant Control System Interface

Ethernet I/P (Ethernet Industrial Protocol) is the preferred LAN (Local Area Network) between Local Chiller Control Panels. Ethernet I/P allows full management of the **YORK®** Industrial Control Retrofit panel from a central location.

All required analog and discrete data for communications will be arranged in blocks of IEEE Floating Point and 16-bit words within the Logix processor's data tables. All data is available remotely as read only values. The following write-able control signals are available. Remote Start, Remote Stop, Remote Leaving Chilled Water Setpoint, and Remote Demand Limit Setpoint.

### Standard Available Network Protocols

REQUIRED (CHECK)	MEDIA	PROTOCOL
-	Ethernet CAT-5	Ethernet Industrial Protocol <a href="http://www.ethernet-ip.org">www.ethernet-ip.org</a>
-	Ethernet CAT-5	Modbus TCP/IP
-	Ethernet CAT-5	Allen-Bradley DF1 via PCCC/EIP
-	RS-232	Allen-Bradley DF1 Full Duplex
-	RS-232	Telemecanique Uni-Telway Slave
-	RS-232	Modbus RTU Slave
X	RS-485	Modbus RTU Slave
-	RS-232	Modbus ASCII Slave
-	RS-485	Modbus ASCII Slave
-	RS-232	BACnet MS/TP
-	RS-485	BACnet MS/TP
-	Ethernet CAT-5	BACnet UDP/IP Slave
-	Ethernet CAT-5	BACnet 802.3 Slave
-	Ethernet CAT-5	Generic Ethernet Industrial Protocol slave adapter
-	Ethernet CAT-5	OPC server
-	Ethernet CAT-5	Virtual HMI via web browser
-	-	For more options see <a href="http://www.redlion.net">www.redlion.net</a>

All DCS / BAS communication interface wiring and hardware, which is required external to the chiller control panel, will be supplied and installed by others.

## **Installation Requirements**

### **INPUT POWER REQUIREMENTS**

- Supply – 115VAC 5 KVA (nominal), (50/60) HZ
- Analog Input – 4-20mA, 24VDC
- Analog Output – 4-20mA
- Digital Input – 120 VAC
- Digital Output – 120 VAC
- Control Wiring – 120VAC, 300V, 90 °C

### **WIRE REQUIREMENTS**

- Supply – Insulated stranded copper conductor 6 AWG, 300V, 90 °C
- Analog Input – Shielded 2 conductor cable, 18 AWG
- Analog Output – Shielded 2 conductor cable, 18 AWG
- Digital Input – Insulated stranded copper conductor, 18 AWG, 300V, 90 °C
- Control Wiring – Insulated copper conductor 300V, 90 °C

### Field Installed Components (standard industrial end-devices)

The following items are shipped loose for field installation. End Devices will be at installed at the source to minimize piping and reduce potential leaks.

AMETEK fixed range pressure transmitters will be provided for points specified on the Input / Output List. Lockable stainless steel ball valves are included for each root connection.



Temperature sensors will be National Basic Sensor (NBS), 3-wire, 100 ohm platinum RTDs with NBS temperature transmitters. Ranges will be selected to cover all expected operating conditions, but kept to a minimum to ensure best possible accuracy. Temperature sensors/transmitters will be provided for the points specified on the Input / Output List.

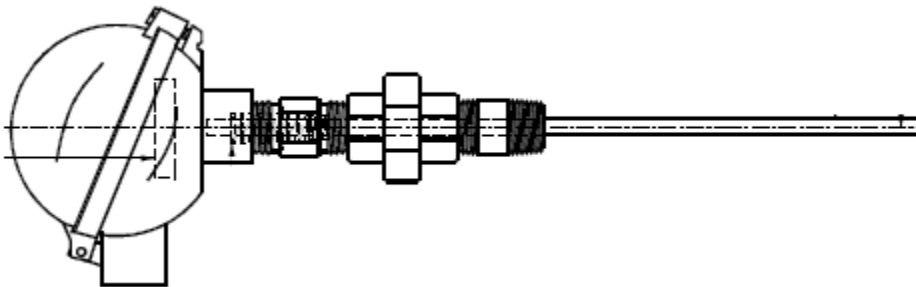

If new sensors are required, information supplied will need to include element lengths and diameter. If sensor isn't existing, the well insertion length and process connection size will need to be provided. This information should be supplied with the order.

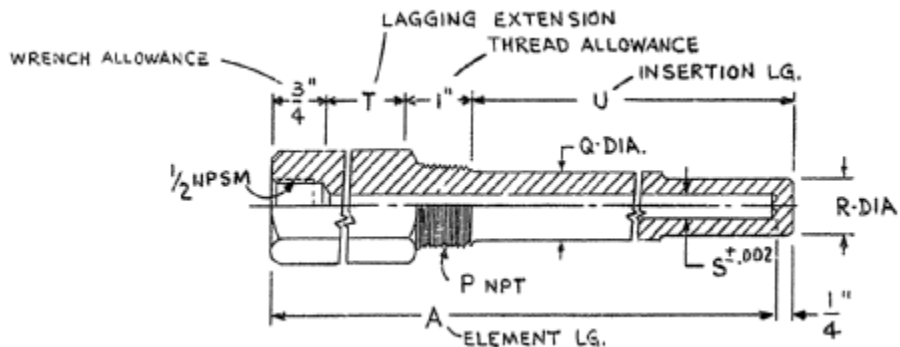

(example)

Temperature Sensors will be equipped with FlexTop Head mounted transmitter.



The refrigerant liquid level transmitters will be a Hansen (or Innovative Tech) capacitance type sensor and are field installed in a connection on the lower side of the condenser and on the level column of the Flash Economizer(s).



All new safety switches will be ITT Neo-Dyn. The condenser refrigerant high-pressure safety switch will be hardwired to the control circuit and will be field installed without any intervening stop valve, as required by ASHRAE-15 safety code.



Brandt Electro-Pneumatic Transducers with 4-20mA DC input and 3-15 psi output will be provided for the compressor pre-rotation vanes, hot gas valve, interstage valve, and level control valves.



An NK Technologies current transmitter will be provided to sense the main compressor motor current. The instrument will deliver a 4-20mA signal with a range greater than 100% of full load, to indicate an overload condition.



**ALTERNATE Field Installed Components (Premium End-devices - NEMA 4X)**

Rosemount Model pressure transmitters with integral displays will be provided for points specified on the Input/Output List, and will be field installed on the unit. Lockable stainless steel ball valves (Apollo) are included for each root connection.



Temperature sensors will be Rosemount, 3-wire, 100 ohm platinum RTDs with temperature transmitters. Ranges are selected to cover all expected operating conditions, but are kept to a minimum to ensure best possible accuracy. Temperature sensors / transmitters are provided for the points specified on the Input / Output List.



If new sensors are required, information supplied will need to include element lengths and diameter. If sensor isn't existing, the well insertion length and process connection size will need to be provided. This information should be supplied with the order.

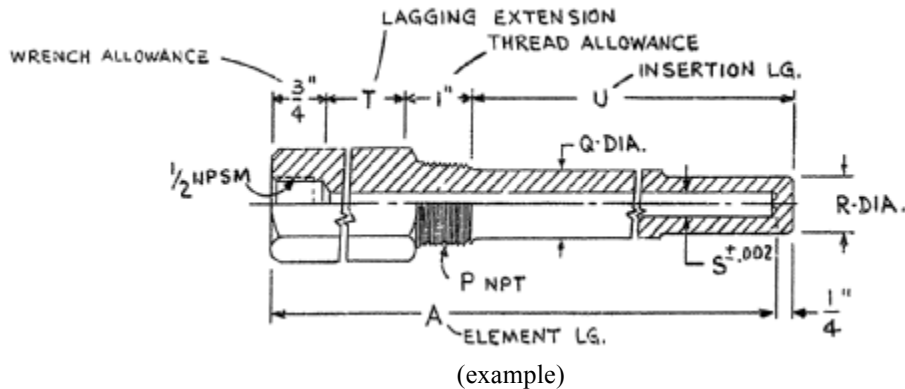

The refrigerant liquid level transmitters will be a Hansen (or Innovative Tech) capacitance type sensor and are field installed in a connection on the lower side of the condenser and on the level column of the Flash Economizer(s).



All new safety switches will be ITT Neo-Dyn. The condenser refrigerant high-pressure safety switch will be hardwired to the control circuit and will be field installed without any intervening stop valve, as required by ASHRAE-15 safety code.



Brandt Electro-Pneumatic Transducers with 4-20mA DC input and 3-15 psi output will be provided for the compressor pre-rotation vanes, hot gas valve, interstage valve, and level control valves.



An NK Technologies current transmitter will be provided to sense the main compressor motor current. The instrument will deliver a 4-20mA signal with a range greater than 100% of full load, to indicate an overload condition.



If present the following components will be re-used unless specifically supplied.

- Flow Transmitters utilized for water flow measurement
- Control Valves and pneumatic actuators.
- Existing flow or differential pressure switches utilized for flow safety protection
- Existing motor starters (i.e. compressor, oil pump, AOP, condensate return pump etc)
- Existing heaters (i.e. compressor oil, gear oil, motor space heater, etc.)
- Existing solenoid valves (i.e. oil cooler, purge, sump vent, etc.)
- Interlock/Interfaces with other system components

All calibrated instruments shall have traceable documentation.

Software safety points will replace hardwired safety switches where possible, for increased reliability.

## Preliminary Input/Output Control Points

The following are typical Input/Output points of control. Final Input/Output list shall be the result of a detailed equipment survey and firm scope development.

### Compressor and System

- Entering Process Temperature, AI
- Leaving Process Temperature, AI
- Evaporator Refrigerant Pressure, AI
- Entering Condenser Water Temperature, AI
- Leaving Condenser Water temperature, AI
- Condenser Refrigerant Pressure, AI
- Refrigerant Level Indication, AI
- Refrigerant Level Control valves, AO
- Hot gas valve, AO
- Interstage Pressure, AI
- Interstage Valves, AO
- Compressor Oil Pressure, AI
- Compressor Oil Temperature, AI
- Compressor Discharge Temperature, AI
- Compressor High Discharge Pressure switch, DI
- Compressor Capacity Control, AI
- Process Flow Switch, DI
- Condenser Flow Switch, DI
- Compressor Oil Pump Motor Starter Interface, DO
- Compressor Oil Cooling Solenoids, DO
- Compressor Oil Heaters, DO
- Vibration Monitoring System Interface DI or AI

### Electric Motor Drive

- Compressor Motor Starter Interface, DI & DO
- Motor Amps, DI
- Speed Increaser Oil Pressure, AI
- Speed Increaser Oil Temperature, AI
- Speed Increaser Oil Pump Motor Starter Interface, DO
- Speed Increaser Oil Cooling Solenoids, DO
- Vibration Monitoring System Interface, DI or AI

[Click here to enter text.](#)

[Click here to enter text.](#)

**Pricing**

Total Project price for services outlined above.....\$

Budget pricing is being provided as an aid for customer to develop project justification and support for establishing project funding. A firm priced offer will be provided after customer budget approval and further discussion of specific scope requirements.

JCI shall retain all right, title, ownership and interest in and to any (a) deliverables provided to customer hereunder, including without limitation, all software source and object code, documentation, technical information or data, specifications and designs and any changes, improvements or modifications thereto or derivatives thereof (“Deliverables”) and (b) Know-How (defined below) employed by JCI in the creation of the Deliverables or performance of the Services, whether known to JCI prior to, or developed or discovered or acquired in connection with, the performance of its obligations hereunder. Ownership of all Deliverables and Know-How shall vest solely in JCI and no Deliverables shall be deemed “works made for hire.” Without limiting the generality of the foregoing, ownership of all source files used in the course of performing the Services shall remain the exclusive property of JCI. For purposes of this Agreement, “Know-How” means any know-how, processes, techniques, concepts, methodologies, tools, analytical approaches, database models and designs, discoveries, and ideas furnished, produced by, developed, employed or used by JCI in the creation or provision of the Deliverables or in the performance of the Services, and any changes, improvements or modifications thereto or derivatives thereof. Under no circumstances shall customer obtain access or ownership to any JCI proprietary information, including, but not limited to, source codes, object codes, specifications and designs.

Any eventual order would be in accordance with the attached terms and conditions.