

Amerigear 200 Series Flexible Couplings Large Bore Couplings

P-6001

Service & Installation Instructions

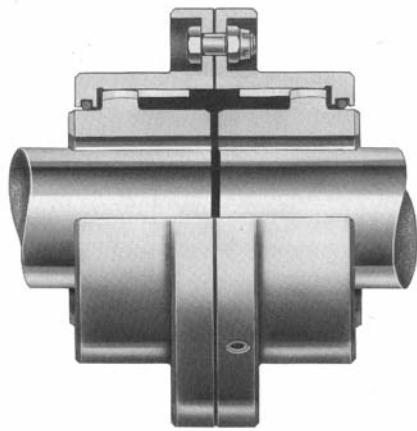

Series F
Standard Flanged-Sleeve
Flexible Coupling

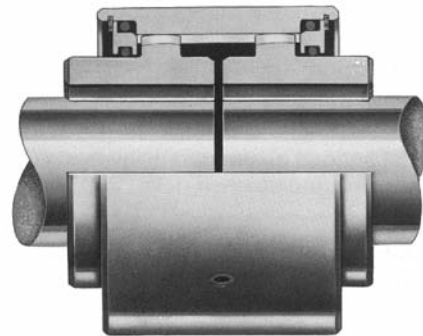

Series C
Standard Continuous-Sleeve
Flexible Coupling

 **Ameridrives**[®]
Couplings

An Altra Industrial Motion Company

Alignment and Installation

Class III, Series F Flexible Coupling components are serialized. Each hub and its mating sleeve are marked as end "A" or "B" and must be assembled accordingly.

NOTE: Amerigear Couplings are not lubricated when shipped. Follow procedures contained herein.

CAUTION Prevent accidental injury from this rotating equipment. Install suitable coupling guard before starting equipment.

CAUTION Torque flange fasteners to tabulated values (see page 3).

Purpose: The purpose of aligning equipment is to avoid transmission of unwanted stresses to bearings, shafts, couplings, etc.

How: By providing minimum angularity and offset of shaft axis at normal operating conditions (Figs. 1 and 2).

Why: To increase life of bearings, couplings, shafts and seals. To get at the root of serious malfunctions involving shutdowns and costly repairs.

When:

1. During installation, before grouting.
2. Immediately after initial operation.
3. When final operating conditions and final temperature are attained.
4. Seasonally.
5. Whenever first symptoms of trouble occur — vibration, undue noise, sudden overheating of bearings.

Practical Considerations:

1. Verify shaft separation.
2. Locate rotor in running position (for example, on sleeve bearing motors).
3. Anticipate thermal changes.
4. Read instructions and review drawings.

Tools:

1. Dial indicator with attaching device.
2. Feeler gauges.
3. Inside micrometer.
4. Outside micrometer.
5. Snap gauges.
6. Straightedge.

Angular Misalignment Measurement:

1. Measure at 4 points the space between the shaft ends (Fig. 3).
2. Rotate both shafts 180° and repeat.
3. Perform calculations for angle.

Offset Misalignment Measurement:

1. Rotate shaft A (with dial indicator mounted) and note readings of shaft B offset (Fig. 4).
2. Or use straightedge and feeler gauge (Fig. 5).

WARNING Misalignment at installation should not exceed 1/3 of rated catalog misalignment.

CAUTION Rotating equipment is potentially dangerous and could cause injury or damage if not properly protected. Follow applicable codes and regulations.

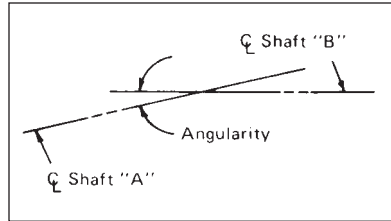

Figure 1 — Angularity is the acute angle formed at the intersection of the axes of the driving and the driven machine shafts. When shafts are exactly parallel, angular misalignment is zero; but vertical or horizontal displacement of axes may be present (See Fig. 2).

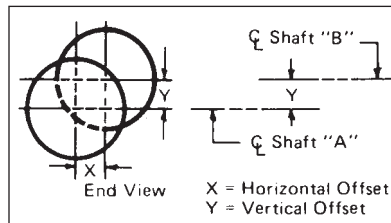

Figure 2 — Concentric alignment (also called offset alignment or parallel offset) is the relationship between the shaft axes in terms of vertical and horizontal displacements of the axis of one shaft from the axis of the other shaft.

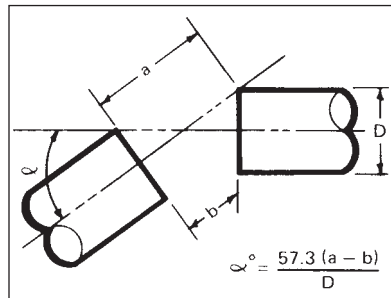

Figure 3 — To determine relative angular shaft-positions of driving and driven machines, measure at four points the space between the shaft ends. Choose the largest (a) and smallest dimension (b).

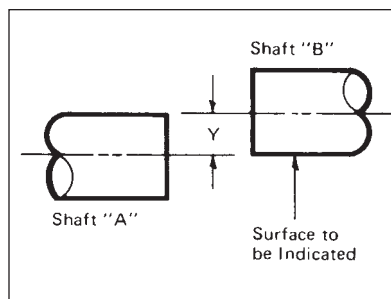

Figure 4 — To measure offsets with a dial indicator, attach the indicator to shaft "A," rotate shaft, and indicate to the periphery of shaft "B." To obtain actual displacements of shafts, divide dial indicator readings by 2.

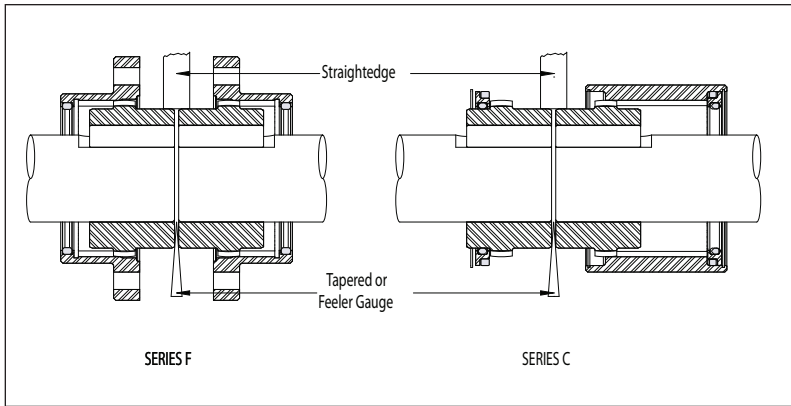
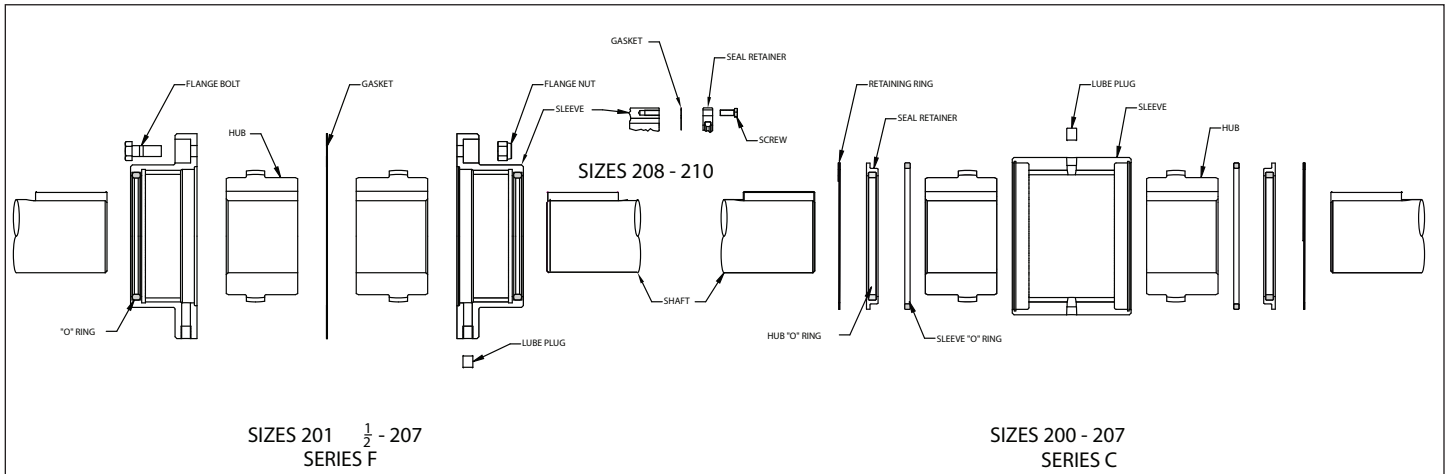

Figure 5 — Lay straightedge on one hub and measure gap between straightedge and other hub with feeler gauge. Measure at top, bottom, and both sides. Feeler gauge readings indicate actual displacements of shafts.

Installation and Lubrication



Installation

Disassemble coupling and clean all parts. Follow the appropriate 6 steps below and you are ready to go! Installed and lubricated in accordance with the instructions, your Amerigear 200 Series coupling is prepared for a life of dependable, trouble-free service.

Series F Installation

Step 1. Lightly coat grease on “O” rings and insert “O” rings into grooves of sleeve (into grooves of seal retainer for sizes 208 and larger). Place sleeves for sizes 200-207 over shaft ends. For sizes 208 and larger, place only the seal retainers with “O” rings inserted, on shaft. Care should be taken not to damage seal on shaft key seat.

Step 2. Check key fits and coat keys and keyways with oil resistant sealing compound (Permatex No. 2) to prevent leakage. Install size 201 to 207 hubs on shafts with long ends flush with shaft ends. Install size 200 hub on shaft with short end flush with shaft end. For shrink fits, apply heat to hubs uniformly, preferably submerged in oil not exceeding 350° F. Do not allow “O” ring seals to contact heated hubs.

⚠ CAUTION Care must be taken to avoid personal injury in the heating and handling of coupling hubs that are shrink fit shaft mounted.

For sizes 208 and larger, place retainer gaskets and sleeves over hubs and onto shafts.

Step 3. Align shafts allowing clearance as per tabulation or in accordance with Dimension “D” from Engineering Data. Check gap with taper or feeler gauge at 90° points and align hubs with straightedge at 90° points.

Step 4. After thoroughly coating hub and sleeve teeth with lubricant, slip sleeves onto hubs, carefully engaging teeth (do not damage seal surface). Place sleeve gasket between sleeves and align bolt holes.

Step 5. Secure sleeves, using care to tighten fasteners uniformly. See tabulation “Flange Bolt Tightening Torque.” For sizes 208 and larger, bolt seal retainers to sleeves.

Step 6. Remove both Dryseal lube plugs and add grease in the amount given in the Lubricant Quantity Table. Install lube plugs using Permatex No. 2 for sealing and seat securely.

Series C Installation

Step 1. For sizes 200-207 place retainer ring, seal retainer with “O” ring seated in retainer groove, and sleeve “O” ring on each shaft. For sizes 208 and larger, place seal retainer with “O” ring inserted, and gasket over shaft. For CS Series, place retainer ring on shaft on which CS rigid hub will be mounted.

Step 2. Check key fits and coat keys and keyways with oil resistant compound to prevent leakage. Install hubs on shafts with short ends flush with shaft ends. For shrink fits, apply heat to hubs uniformly, preferably submerged in oil not exceeding 350°F. Do not allow “O” rings to contact heated hubs.

⚠CAUTION Care must be taken to avoid personal injury in the heating and handling of coupling hubs that are shrink fit shaft mounted.

Step 3. Slip sleeve over hub mounted on longest shaft.

Step 4. Align shafts allowing clearance as per tabulation or from Engineering Data, Dimension “D.” Check gap with taper or feeler gauge at 90° intervals. Also align hubs with straightedge at 90° points.

Step 5. Pack hub and sleeve teeth with grease. Force grease into shaft gap. Lightly coat grease on “O” rings. Slide sleeve over hubs to center position. Remove Dryseal lube plugs and add grease in the amount given in the Lubricant Quantity Table.

Step 6. For sizes 200-207, install sleeve “O” rings in sleeve counterbores — then press seal retainer assembly in place. Use fingertips or blunt tool. Seat retaining rings in grooves using a winding motion. Recheck to assure retaining rings are positively seated. For sizes 208 and larger, bolt seal end plates to sleeves.

SIZE	HUB SEPARATION			FLANGE BOLT TIGHTENING TORQUE FT.LBS.*	
	F & C	FS	CS	F Exposed	F Shrouded
200	.125	.078	.125	10	10
201	.125	.078	.125	10	10
201¼	.125	.078	.125	10	10
201½	.125	.156	.125	29	32
202	.125	.156	.125	63	32
202½	.188	.188	.188	125	69
203	.188	.188	.188	125	69
203½	.250	.219	.250	210	133
204	.250	.312	.250	210	133
204½	.312	.344	.312	210	133
205	.312	.344	.312	313	232
205½	.312	.344	.312	313	232
206	.312	.406	.312	313	340
207	.375	.500	.375	440	476
208	.375	.500	—	600	
209	.500	.562	—	800	
210	.500	.625	—	1,200	

*Tightening torque based on unlubricated threads; if threads are lubricated derate torque to 75% of above values.

Maintenance and Lubrication

MANUFACTURER	GENERAL	MOIST / WET	HIGH TORQUE	150 – 300°F (65 -150°C)	CLASS III
American Lubricants Co. (Dayton, OH)	Alubco Bison 1650	Alubco Bison 1650	Alubco Bison 1650	Alubco Bison 1650	Alubco Bison 1650
Brooks Technology (Cleveland, OH) (Fuchs Lubricants)	Superplex EP #1 or Benalene 350 EP #2	Superplex EP #1 or Benalene 350 EP #2	Superplex EP #1 or Benalene 350 EP #2	Superplex EP #1 or Benalene 350 EP #2	–
Chevron Lubricants			Coupling Grease or Duralith EP2	Duralith EP2 or Rykon Premium EP#2	Coupling Grease or Gear Compound EP 460
Citgo Petroleum Corp.	Premium Lithium EP2	Premium Lithium EP2	Premium Lithium EP2	Premium Lithium EP2	EP Compound 460 or AP Grease
Exxon / Mobil Corp.	Mobilux EP 111	Mobilux EP 111	Mobilux EP 111	Mobiltemp 78 or Unirex N2	Mobilgrease 28 or Mobilgrease XTC or Teresstic 460
Fiske Bros. Refining Co.	Lubriplate 630AA	Lubriplate 630AA	Lubriplate 630AA	Lubriplate 1200-2	Lubriplate #8 (Gear Oil) ISO 460
Anderol Inc. (Houghton Canada)	Anderol 786	Anderol 786	Anderol 786	Anderol 786	Anderol 786
Kendall Motor Oil	L-424	L-424	–	L-424	L-427 Super Blu
Lyondell Lubricants (Houston, TX)	Litholene H EP2	Litholene H EP2	Litholene H EP2	–	Pennant NL 220
Maryn International / Power Up Lubricants (Calgary, Canada)	Thixogrease EP #2	Thixogrease EP #2	Thixogrease EP #2	Thixogrease EP #2	Thixogrease EP #2
Pennzoil / Quaker State	Pennlith EP711 or Pennlith EP712	Pennlith EP711 or Pennlith EP712	Pennlith EP711 or Pennlith EP712	Pennzoil 707L or Pennlith EP712	Super Maxol EP460
Syn-Tech Ltd. (Addison, IL)	NS-3913-G1	NS-3913-G1	NS-3913-G1	NS-3913-G1	NS-3913-G1
Texaco Inc.	Multifax EP2 or Texaco Coupling Grease	Multifax EP2 or Texaco Coupling Grease	Multifax EP2 or Texaco Coupling Grease	Thermatex EP2	Texaco Coupling Grease
UNOCAL 76 (TOSCO Corporation)	UNOBA EP2	UNOBA EP2	UNOBA EP2	UNOBA EP2	MP Gear Lube 85W-140

LUBRICANT QUANTITIES

Coupling Size	LUBRICATION			
	SERIES F*		SERIES C	
	Wt. Lbs.	Vol. Qts.	Wt. Lbs.	Vol. Qts.
200	.020	.010	.015	.008
201	.045	.025	.036	.020
201¼	.069	.033	.045	.025
201½	.140	.070	.080	.040
202	.200	.110	.080	.040
202½	.380	.200	.160	.090
203	.540	.290	.240	.120
203½	.820	.430	.240	.120
204	1.080	.580	.440	.240
204½	1.540	.820	.540	.290
205	2.580	1.380	1.000	.530
205½	3.120	1.660	1.120	.590
206	3.480	1.860	1.020	.540
207	7.040	3.760	2.700	1.440
208	9.160	4.840	5.580	2.970
209	11.700	6.240	7.620	4.060
210	14.140	7.540	9.500	5.050

Maintenance - The Amerigear Coupling requires a minimum of maintenance. Nevertheless, to ensure a trouble-free life a few checks and proper lubrication should be performed at regular intervals.

Ameridrives suggests that the maximum interval between checks and relube be one year. This is only a guide, and the actual interval should be in accordance with good operating practices for application.

To disassemble Series F, remove flange fasteners, separate sleeves, slide sleeves over hubs, clean out old lubricant, and inspect seals and gear teeth. Reassemble, starting with Step 3 under Series F installation instructions on the previous page.

To disassemble Series C, remove one snap ring, slide sleeves off hubs, clean out old lubricant and inspect seals and gear teeth. Reassemble, starting at Step No. 4 under Series C installation instructions on the previous page.

If proper alignment of shafts is assured and it is not practical to disassemble coupling, remove both lube plugs and add grease in sufficient amount to overflow with lubricant holes in horizontal position. Recommended lubricants and quantities are listed on this page.

NOTE: Sizes 200 and 201 Series C are supplied without lube plugs – lubricate per Series C, Step No. 5.

The lubricants listed above are recommended by the lubricant manufacturers for the indicated conditions. Those shaded are reported by lubricant manufacturers to comply with the intent of AGMA 9001. This list is solely for our customers' convenience and does not constitute an endorsement. The listing is not intended to be complete nor necessarily current due to continuous research and improvement by the various manufacturers.

Series F, FM, FA, FE use quantities recommended. For FE, apply one-half in one end and one-half in other end. **Series ES, EMS, FAS** use one-half the quantities recommended. **Series C, CM, CA** use quantities as shown.

Series CS, CMS, CAS use one-half the quantities recommended.

***Series F, Class III** use quantities as recommended for Series F but limited to the greases shown in Class III column above or the following oils: Citgo EP Compound 460 by Citgo Corp.; Teresstic 460 by Exxon; Lubriplate No. 8 by Fiske Bros.



P-6001 • 104-SHA 5/09

Ameridrives Couplings
1802 Pittsburgh Avenue • Erie, PA 16512
814-480-5000 • Fax: 814-453-5891
www.ameridrives.com
An Altra Industrial Motion Company

Printed in USA