

SmartPurge™ Retrofit Overview

BACKGROUND

York's ParaFlow enjoys a significant portion of the two stage absorption chiller market. To maintain our position, we are constantly improving the design of our equipment. One improvement we have made is in the Paraflow purge system. York's two-stage absorbers operate in a vacuum and are susceptible to air infiltration. Air that enters the chiller must be purged from the system to avoid internal corrosion and to maintain peak performance.

Chillers shipped before January 1997 require manual purging. This process can be time consuming and is often considered a major inconvenience. Customers have asked for an automatic purge system. In response to their request we have recently developed the SmartPurge™ (standard for all new absorption units) and the SmartPurge™ Retrofit for existing units.

The SmartPurge™ which is wired to the MicroPanel senses the pressure within the absorption units purge tank and automatically empties its contents when the tank is full. The MicroPanel alerts the operator if the unit is purging to frequently. This system eliminates labor and maintenance since no personnel is needed to purge the tank.

RETROFIT APPLICATION

The SmartPurge™ Retrofit is available for the following units:

- York ParaFlow direct-fired "G" and "S" series
- York ParaFlow steam "G" and "S" series
- Hitachi absorbers that have a York MicroPanel retrofit

It is not available for any other type of absorption unit.

Installation of the SmartPurge™ includes several pressure transducers, valves and an E-Prom change out. All absorbers receiving a SmartPurge™ Retrofit will require some piping modifications. One of these modifications will include installing a pressure transducer isolation valve (PTI valve) into the purge tank. However, in anticipation of the SmartPurge™ Retrofit, many late model absorbers have been equipped with this valve. These units will require significantly less piping labor. For more information on identifying whether or not the valve has been factory installed, refer to the attached Installation Instructions.

HOW IT WORKS

An absorption unit's general health can be quickly determined by the quantity of non-condensables it produces. A properly maintained ParaFlow unit will produce very few non-condensables, the fewer the better. A small amount of internally generated gases will always be present and should be considered normal. Air leaks, no matter how small, will almost always cause noticeable increases in the amount of non-condensables a unit produces. Since it is important to correct any air leaks as soon as possible, it is essential to develop a disciplined method of purging units so that any abnormalities can be discovered quickly. Units with SmartPurge™ will automatically evacuate only when necessary and the frequency of evacuation is continuously monitored.

SmartPurge™ consists of hardware and software that monitors the purge tank pressure, purges it when needed and records the event. SmartPurge™ will also alert the user if purging is excessive. By utilizing two pressure transducers, SmartPurge™ continuously watches the purge pump performance and stops the purging process if a problem occurs.

STRATEGY

Most ParaFlow chiller owners have inquired about some type of automatic purge system. Since no other manufacturer can offer anything comparable to the SmartPurge™, this York Enhancement Service (YES) product should be well received in the marketplace and very profitable. The following features and benefits should be covered with your customers:

Feature	Benefit
<ul style="list-style-type: none">• Automatically removes non-condensables that can corrode absorber	<ul style="list-style-type: none">• Extend equipment life• Protect investment
<ul style="list-style-type: none">• Keep non-condensibles from raising operating pressures	<ul style="list-style-type: none">• Maintain peak performance
<ul style="list-style-type: none">• Full automatic operation	<ul style="list-style-type: none">• Saves maintenance labor• No worry of neglect or abuse
<ul style="list-style-type: none">• Digital technology	<ul style="list-style-type: none">• Accurate operation
<ul style="list-style-type: none">• Warning message output to micropanel display or to your BAS	<ul style="list-style-type: none">• Early warning system

BROCHURE

A sales brochure has been created to help you communicate all the features and benefits of the SmartPurge™ to your customers. Form: 50.40-SG28

FIELD TRIALS

Field trials exist at the following locations:

- 1) Blue Cross Blue Shield (Chicago, IL)
- 2) Lafayette General Hospital (Lafayette, LA)

Both field trials have been operating very well. Procedures that facilitate the installation have been outlined in the Installation Instructions.

PRICING

Kits for the SmartPurge™ can be order from the Baltimore Parts Warehouse

• SmartPurge™ Retrofit Kit	
Part Number	325-32967-000
Master List Price	\$3296.59
SQ Multiplier is applicable	
• Estimated Labor	
Factory Installed PTI Valve	36 man hours
Field Installed PTI Valve	44 man hours
• Suggested Selling Price	\$8,000 - \$12,000

INSTALLATION INSTRUCTIONS

A comprehensive set of Installation Instructions will be shipped with the SmartPurge™ Retrofit Kit (see attached).

HIT LIST

Attached is a list of all ParaFlow chillers that have been shipped through January 1997. This list is sorted by state. In most cases, determination of whether the unit has a factory installed pressure transducer isolation valve has been indicated. Visual verification is recommended.

SUPPORT

For marketing support, please call Victor Chael at 717-771-6243.

For technical support, please call Rick Nadeau at 717-771-6589.

York 2-Stage Absorption Installation List

State	Location	Model #	Project Name	Factory Installed	
				PTI Valve *	York Order #
AL	Mobile	YPC-DF-16G	PROVIDENCE HOSPITAL	N	91829296
AR	Little Rock	YPC-ST-20G-46-C-S	Baptist Medical Center	N	92912078
AZ	Phoenix	YPC-FD-18G-46-S-S-A	Arizona State Hospital	N	94166128
AZ	Phoenix	YPC-FD-14S-46-C-S-A	AZ Precision Sheet Metal A	Y	93166121
AZ	Phoenix	YPC-FD-14S-46-C-S-A	AZ Precision Sheet Metal B	Y	93166121
AZ	Phoenix	YPC-DF-17G-46-S-A	Phoenix Federal Courthouse	N	92932037
AZ	Peoria	YPC-FD-12SC-46-C-S-B	Sunrise Mountain High School	Y	95166231
CA		YPC-FN-16G-46-H-A	66O Newport Center	N	92931339
CA	Los Angeles	YPC-FN-16G-46-C-S-A	Bullocks-Macy's A	Y	94102171
CA	Los Angeles	YPC-FN-16G-46-C-S-A	Bullocks-Macy's B	Y	94102171
CA	San Diego	YPC-DF-18G	General Mail Facility	N	91931062
CA	Malibu	YPC-FN-14S-46-H-S-B	Hughes Research Labs	Y	94161165
CA	Long Beach	YPC-DF-20G	Long Beach Conv. Ctr.	N	92931105
CA		YPC-FN-16G-46-C-A	R. R. Donnelly	N	92931297
CA	Downey	YPC-ST-21G-17-C-A	Rancho Los Amigos Med. Ctr.	N	92161933
CA	Downey	YPC-ST-21G-17-C-A	Rancho Los Amigos Med. Ctr.	N	92161933
CA	Downey	YPC-ST-21G-17-C-A	Rancho Los Amigos Med. Ctr.	N	92161933
CA	Los Angeles	YPC-ST-15GL	UCLA	N	92931256
CA	Redlands	YPC-FN-17G-46-C-S	University of Redlands	N	94161104
CA		YPC-FX-16G-46-H-S	Valencia Mail	N	92931158
CA		YPC-FX-16G-46-H-S	Valencia Mail	N	92931158
CA		YPC-FX-16G-46-H-S	Valencia Mail	N	92931158
CA		YPC-FN-16G-46-C-X	Ventura County Jail	N	92931260
CA	Scotts Valley	YPC-FN-16G-46-C-A-A	Watkins-Johnson	N	94164129
CT	WALLINGFORD	YPC-ST-22G-46-C-A	BRISTOL MYERS / SQUIBB	N	91804220
CT	Bethel	YPC-FN-17G-46-H-S-B	Duracell A	Y	94102824
CT	Bethel	YPC-FN-17G-46-H-S-B	Duracell B	Y	94102824
CT	E. Hartford	YPC-DF-14G	E. Hartford High School	N	92803976
CT	Greenwich	YPC-FD-16G-17-H-A-A	Greenwich High School A	N	94102808
CT	Greenwich	YPC-FD-16G-17-H-A-A	Greenwich High School B	N	94102808
CT	Hartford	YPC-FN-17G-46-S-A-B	Hartford Post Office	?	95105042
CT	Hartford	YPC-FD-14SC-46-H-S	Hartford Post Office	?	96105005
CT	New Britain	YPC-ST-20G-17-C-A	New Britain General Hosp.	N	93102811
CT	New Britain	YPC-ST-16G	New Britain Mem. Hospital	N	92803977
CT	Hamden	YPC-FN-15S-46-C-S-A	Quinnipiac College A	N	94102814
CT	Hamden	YPC-FN-15S-46-C-S-A	Quinnipiac College B	N	94102814
CT	New Haven	YPC-ST-18G-46-C-S	St. Raphael	N	92803819
CT	West Haven	YPC-ST-20G-46-C-A	V.A. West Haven	N	92803800
DC	Washington	YPC-FD-15S-46-S-S-B	American Council for Education	Y	94112253
DE	Wilmington	YPC-ST-22G-46-C-X-A	E.I. Du Pont De Nemours & Co.	?	93211038
DE	Wilmington	YPC-ST-22G-46-C-X-A	E.I. Du Pont De Nemours & Co.	?	94211016
DE	Wilmington	YPC-ST-22G-46-C-X-A	E.I. Du Pont De Nemours & Co.	?	94211016
DE	Wilmington	YPC-ST-22G-46-C-X-A	E.I. Du Pont De Nemours & Co.	?	94211016
FL	Cape Coral	YPC-FX-17G-46-C-A	Cape Coral Hospital	N	92824022
FL	Miami	YPC-HR-19GL	North Shore Medical Ctr.	N	92824875
FL	Jacksonville	YPC-ST-18G-46-C-S	University Medical Center #1	N	92826333
FL	Jacksonville	YPC-ST-18G-46-C-S-A	University Medical Center #2	N	93226002
GA	Atlanta	YPC-FN-14SC-17-H-S	Atlanta Gas	Y	96121412
GA	Barnesville	YPC-FN-19GL-46-C-S-B	General Tire	N	94121145
GA	Forsyth	YPC-FD-20G-46-C-A	UPS Data Center A	N	93121105
GA	Forsyth	YPC-FD-20G-46-C-A	UPS Data Center B	N	93121105
IL		YPC-ST-21G-46-C-X	Abbott Labs	N	92901155
IL	Abbott Park	YPC-FN-20G-46-C-A	Abbott Labs	N	96141333
IL	Chicago	YPC-DF-11SL	American College of Surgeons	N	92901456
IL	Chicago	YPC-DF-21G	AT&T Bell Labs	N	92901249
IL	Chicago	YPC-DF-21G	AT&T Bell Labs	N	92901249
IL	Chicago	YPC-FN-14SC-46-S-S	Belmont House	Y	96141358
IL	Chicago	YPC-FN-14SC-46-S-S	Belmont House B	Y	96141358

State	Location	Model #	Project Name	Factory Installed	
				PTI Valve *	York Order #
IL	Waukegan	YPC-FD-15S-46-C-S-B	Blue Cross A	Field Trial	94141208
IL	Waukegan	YPC-FD-15S-46-C-S-B	Blue Cross B	Field Trial	94141208
IL	Oaklawn	YPC-ST-18G-46-C-A	Christ Hospital	N	92901339
IL	Chicago	YPC-FN-14S-46-H-S-A	CTA	N	93141023
IL	Chicago	YPC-FN-16G-46-H-S	CTA	?	93141023
IL		YPC-FN-13S-46-C-A-B	Great Lakes Naval Training A	Y	95141223
IL		YPC-FN-13S-46-C-A-B	Great Lakes Naval Training B	Y	95141223
IL	Great Lakes	YPC-FN-16G-46-C-A-B	Great Lakes NTC	Y	95141266
IL	Chicago	YPC-ST-16G	Harper College	N	92901334
IL	Chicago	YPC-FN-17G-46-C-A	Illinois Psychiatric	N	92901259
IL	Chicago	YPC-FN-17G-46-C-A	Illinois Psychiatric	N	92901259
IL	Joliet	YPC-FN-16G-46-H-A-A	Joliet Junior College	N	94141135
IL	Chicago	YPC-FD-18G-46-C-A	Jones High School	N	93141040
IL	Chicago	YPC-FN-14S-17-H-A-B	Knickerbocker Hotel A	Y	94141210
IL	Chicago	YPC-FN-14S-17-H-A-B	Knickerbocker Hotel B	Y	94141210
IL	Glenview	YPC-ST-18G-46-C-A-B	Kraft Research	Y	94141182
IL		YPC-DF-12SL	LaGrange Hospital	?	93141011
IL		YPC-DF-12SL	LaGrange Hospital	?	93141011
IL	Chicago	YPC-FN-19G-46-H-A	Loyola Business	N	92901353
IL	Chicago	YPC-FN-19G-46-H-A	Loyola Business	N	92901353
IL	Decatur	YPC-ST-16SL-46-C-S-B	Millikin University	Y	95242570
IL		YPC-DF-20G-46-A-S	Moraine Valley	N	92901421
IL	Chicago	YPC-ST-20G-46-C-A	Rockford Medical Center	N	92901450
IL	Palatine	YPC-FN-13S-46-H-A-A	Sanborne Elementary School	?	93141004
IL	Joliet	YPC-ST-20G-46-C-S-B	Silver Cross Hospital	N	94141127
IL	Chicago	YPC-FN-16G-46-H-A-A	UIC Student Services A	N	93141122
IL	Chicago	YPC-FN-16G-46-H-A-A	UIC Student Services B	N	93141122
IL	Chicago	YPC-ST-19G-46-C-A	Warner Lambert	N	93141006
IL	Rockford	YPC-ST-19GL-46-C-A-B	Warner Lambert	Y	95141258
IL		YPC-FN-17G-17-H-S	Winston School	N	92901283
IL		YPC-FN-16G-46-C-A	Woodstock Memorial Hospital	N	93141019
IL		YPC-FN-16G-46-C-A	Woodstock Memorial Hospital	N	93141019
IN	Indianapolis	YPC-FD-16G-46-S-S	Jay County High School	N	92911536
IN	Indianapolis	YPC-FD-16G-46-S-S	Jay County High School	N	92911836
IN		YPC-DF-11SL	N. Indiana Historical Society	N	92901360
KS	Leavenworth	YPC-ST-19G-46-C-A	VAMC A	Y	93213008
KS	Leavenworth	YPC-ST-19G-46-C-A	VAMC B	Y	93213008
KS	Leavenworth	YPC-ST-19G-46-C-A	VAMC C	Y	93213008
LA	Lafayette	YPC-FN-17G-46-H-A-B	Lafayette Hospital	Y	95153255
MA	Boston	YPC-FD-18G-46-H-A	C.F.Hurley #1	N	92802324
MA	Boston	YPC-FD-18G-46-H-A	C.F.Hurley #2	N	92802325
MA	Nattick	YPC-FN-18G-17-H-A	Jordan Marsh Dept. Store	N	93132104
MA	Boston	YPC-DF-11SL	United States Coast Guard	N	92802337
MD	Hunt Valley	YPC-ST-16G	Becton Dickinson	N	93112009
MD	Laurel	YPC-FD-15S-46-S-S-B	Birchwood Garden Apts.	Y	94112181
MD	BALTIMORE	YPC-FN-16G-46-H-S	Iverson Mall (Montgomery Ward)	N	92801006
MD	Baltimore	YPC-FD-17G-46-C-A	Mariner Health	N	92801968
MD	Bethesda	YPC-FD-20G-17-S-A-B	National Naval Medical Center	Y	94112191
MD	Randallstown	YPC-DF-18G	Northwest Hospital (Balt. Co.)	N	92801478
MD		YPC-DF-16G	Oakland Mills High School	N	92880114
MD	Glen Burnie	YPC-FN-14S-46-S-S-A	Rippling Woods Elem. School	Y	94112927
MI	Wyandotte	YPC-DF-12S	Biddle House Condominiums	N	92904171
MI	Detroit	YPC-FN-14SC-46-H-S	Detroit Water Treatment A	Y	94133203
MI	Detroit	YPC-FN-14SC-46-H-S	Detroit Water Treatment B	Y	94133203
MI	Detroit	YPC-FN-17G-46-S-S	Henry Ford Village	N	92801979
MI	Detroit	YPC-FN-17G-46-S-S	Henry Ford Village	N	92801979
MI	Dearborn	YPC-FN-17G-46-H-A	Henry Ford Village A	Y	95133286
MI	Dearborn	YPC-FN-17G-46-H-A	Henry Ford Village B	Y	95133286
MI	Flint	YPC-ST-20G-46-C-A	Hurley Hospital	Y	96217112
MI	Detroit	YPC-ST-21G-46-C-A-A	IRS 1A	?	94133108

State	Location	Model #	Project Name	Factory Installed	
				PTI Valve *	York Order #
MI	Detroit	YPC-ST-21G-46-C-A-A	IRS 1B	?	94133108
MI	Detroit	YPC-ST-21G-46-C-A-A	IRS 2A	?	94133108
MI	Detroit	YPC-ST-21G-46-C-A-A	IRS 2B	?	94133108
MI	Detroit	YPC-FN-15S-46-H-S-B	Reed Building A	?	94133117
MI		YPC-FN-12SC-17-C-S	State of Missouri	Y	96213213
MN	Andover	YPC-FD-14SC-17-H-S-B	Andover Elementary School	Y	95144200
MN		YPC-DF-11SL	Augsburg College	N	92905546
MN	Chaska	YPC-FN-16G-46-H-A	Carver County	N	92905561
MN	Fridley	YPC-FN-13S-46-C-A-A	Healthspan Unity Hospital	Y	93144110
MN		YPC-FN-16G-46-C-S	Luther Hospital	N	91905509
MN	Maple Grove		Maple Grove High School	?	95944151
MN	Maple Grove	YPC-FN-15S-46-C-S-B	Maple Grove High School A	Y	94144151
MN	Maple Grove	YPC-FN-15S-46-C-S-B	Maple Grove High School B	Y	94144151
MN	Minneapolis	YPC-FN-14SC-46-C-S	Monco Products	Y	95144214
MN	Anoka	YPC-FD-13SC-46-H-A	Ramsey Elementary School	?	95144197
MO	Florissant	YPC-FN-12SC-17-S-A	Mary Grove Industries	Y	96245460
N.S.W.	Sydney	YPC-FN-18G-50-C-B-A	Northern Development A"IBIS"	N	94971039
N.S.W.	Sydney	YPC-FN-18G-50-C-B-A	Northern Development B"IBIS"	N	94971039
NC	Greenville	YPC-ST-21G-46-C-S	Burroughs Wellcome	N	92818522
NC	Greenville	YPC-ST-21G-46-C-A-B	Burroughs Wellcome	Y	94187189
NE	Omaha	YPC-ST-21G-46-C-S	Bergan Mercy Medical Ctr.	N	92907233
NJ	Basking Ridge	YPC-FD-19G-46-S-A	AT&T Corporate #1	N	93106002
NJ	Basking Ridge	YPC-FD-19G-46-S-A	AT&T Corporate #2	N	93106002
NJ	Trenton	YPC-FD-19G-46-H-S	Campbell Soup A	N	92805045
NJ	Trenton	YPC-FD-19G-46-H-S	Campbell Soup B	N	92805045
NJ	Newark	YPC-FN-16G-17-C-A	Carmel Towers	N	92804384
NJ	Cherry Hill	YPC-FN-18G-46-C-A-A	Elkins-Sinn	N	94111112
NJ	Hazlet	YPC-FD-16G-46-C-A	International Flavors A	N	93106029
NJ	Hazlet	YPC-FD-16G-46-C-A	International Flavors B	N	93106029
NJ	Jersey City	YPC-ST-14G	Jersey City State College	N	92804352
NJ	North Bergen	YPC-FN-14SC-28-H-S	Meer Co.	Y	96106210
NJ	Rahway	YPC-ST-19G-46-C-X	Merck	N	92804244
NJ	Rayway	YPC-ST-17G	Merck Bldg 50	N	91804211
NJ	Rayway	YPC-ST-22G-46-C-A	Merck Bldg. 80	N	91804232
NJ	Rahway	YPC-ST-22G-46-C-A	Merck Bldg. 80	N	91804232
NJ	Pennington	YPC-FD-17G-46-S-A	Mobil Research and Development	N	92805021
NJ		YPC-DF-14G	New Jersey Institute of Tech.	N	92804392
NJ	Newark	YPC-ST-22G-46-C-C-B	Newark Beth Israel Hospital	?	95106156
NJ	Raritan	YPC-ST-22G-46-C-C	Ortho-McNeil Pharmaceutical	?	93106036
NJ	Raritan	YPC-ST-18S-46-C-X	Ortho Diagnostics Systems 'A'	Y	96106243
NJ	Raritan	YPC-ST-18S-46-C-X	Ortho Diagnostics Systems 'B'	Y	96106243
NJ	Trenton	YPC-FD-16G-46-H-S	St. Francis Medical Center	N	92805033
NJ	Atlantic City		Tropicana Casino (TRIGEN)	Y	96111557
NJ	Princeton	YPC-FN-17G-46-C-S	Vision Impact A	N	93106107
NJ	Princeton	YPC-FD-20G-46-C-S	Vision Impact B	N	93106107
NJ	Hawthorne	YPC-FN-16G-46-C-S-B	Wayne General Hospital	Y	94106011
NY	NYC	YPC-ST-21G-46-C-A	110 E. 59th St. A	N	92803008
NY	NYC	YPC-ST-21G-46-C-A	110 E. 59th St. B	N	92803008
NY	NYC	YPC-FN-13S-17-S-S-B	116 Central Park South	Y	95102262
NY	NY	YPC-FN-16G-17-H-A-B	15 E. 57th Street (NY Tech)	N	94102192
NY	NY	YPC-FD-15S-17-H-S-B	160 East 65th St. A	N	94102223
NY	NY	YPC-FD-15S-17-H-S-B	160 East 65th St. B	N	94102223
NY	NY	YPC-ST-20G-46-C-A-A	1700 Broadway (New) A	N	94005020
NY	NY	YPC-ST-20G-46-C-A-A	1700 Broadway (New) B	N	94005020
NY	New York	YPC-FN-14S-17-C-S	175 E. 62nd St.	N	93102106
NY	NY	YPC-FN-14SC-17-C-S-B	201 E. 62nd St.	Y	95102360
NY	NYC	YPC-FD-13S-17-S-A-A	235 E. 87th Street	?	94102102
NY	NYC	YPC-ST-19G-C-A	261 Madison Ave	N	92803009
NY	NYC	YPC-ST-19G-46-C-A-A	425 Park Avenue A	Y	94102174
NY	NYC	YPC-ST-19G-46-C-A-A	425 Park Avenue B	Y	94102174

State	Location	Model #	Project Name	Factory Installed	
				PTI Valve *	York Order #
NY	NYC	YPC-ST-19G-46-C-A-A	425 Park Avenue C	Y	94102174
NY	NY	YPC-FN-17G-17-S-A-B	5030 Broadway A	Y	95102403
NY	NY	YPC-FN-17G-17-S-A-B	5030 Broadway B	Y	95102403
NY		YPC-FN-16G-17-C-A	600 Old Country Road	N	92803661
NY	NYC	YPC-FN-16G-17-C-A	600 Old Country Road	N	92803662
NY	Nanuet	YPC-FN-17G-46-C-S	A&S Dept. Store	Field Trial	93106040
NY	New York	YPC-FD-17G-46-H-A-A	Audubon Research Park A	N	94102103
NY	New York	YPC-FD-17G-H-A-A	Audubon Research Park B	N	94101103
NY	Brooklyn	YPC-DF-12S	BUG-Canarsie	N	93102023
NY	White Plains	YPC-FD-14SC-46-H-S-B	Burke Rehab A	Y	95102382
NY	White Plains	YPC-FD-15SL-46-H-S-S	Burke Rehab B	Y	95102382
NY	White Plains	YPC-FD-14SC-46-H-S-B	Burke Rehab C	Y	95102382
NY		YPC-ST-19G	Cabrini Medical Center	N	92803514
NY		YPC-ST-19G	Cabrini Medical Center	N	92803515
NY		YPC-ST-19G	Cabrini Medical Center	N	92803516
NY	Suffern	YPC-ST-21G-46-C-C-B	Ciba Geigy A	Y	94106210
NY	Suffern	YPC-ST-21G-46-C-C-B	Ciba Geigy B	Y	94106210
NY	Brooklyn	YPC-FN-13SC-17-C-S-B	Clinton Towers	Y	95102374
NY	NYC	YPC-FD-16G-46-H-S	Consolidated Edison	N	92803563
NY	NYC	YPC-DF-18G2	Consolidated Edison	N	92803564
NY	Yonkers	YPC-FN-13S-17-H-A-A	Consumer's Union	?	93102825
NY	Yonkers	YPC-FN-13S-17-H-A-A	Consumer's Union	?	93102825
NY	White Plains	YPC-FN-14S-46-H-S-A	Federal Courthouse A	?	93102824
NY	White Plains	YPC-FN-14S-46-H-S-A	Federal Courthouse B	?	93102824
NY	Bronx	YPC-FN-15S-46-H-S-B	Fordham Library A	Y	95102275
NY	Bronx	YPC-FN-15S-46-H-S-B	Fordham Library B	Y	95102275
NY	Greece	YPC-DF-14G	Greece Athena High School	N	92811447
NY	NYC	YPC-ST-18G-17-C-A	Hippodrome #1	N	92803558
NY	NYC	YPC-ST-18G-17-C-A	Hippodrome #2	N	92803559
NY	Tarrytown	YPC-ST-22G-46-C-A-B	Keren Developments A	?	95105011
NY	Tarrytown	YPC-ST-22G-46-C-A-B	Keren Developments B	?	95105011
NY	New York	YPC-ST-22GL-46-C-A	Kiac Partners (JFK Airport)	N	92803587
NY	NYC	YPC-ST-22G-46-C-A	Kiac Partners (JFK Airport)	N	92803588
NY		YPC-ST-22GL-46-C-A	Kiac Partners (JFK Airport)	N	92803589
NY		YPC-ST-22GL-46-C-A	Kiac Partners (JFK Airport)	N	92803590
NY		YPC-ST-22GL-46-C-A	Kiac Partners (JFK Airport)	N	92803591
NY	Albany	YPC-FD-16G-46-S-A	KTB Printing	N	92803611
NY	Albany	YPC-FD-16G-46-S-A	KTB Printing	N	92803693
NY	NY	YPC-FD-13S-17-H-X-A	Lefrak Queens B "Stock"	N	93102107
NY	NY	YPC-FD-13S-17-H-X-A	Lefrak Queens C "Stock"	N	93102107
NY	NYC	YPC-FN-16G-17-H-A	Local 1199 (ASHRAE Unit)	N	92803732
NY	Long Island	YPC-FN-14S-17-H-S-A	Long Island University A	?	94102146
NY	Long Island	YPC-FN-14S-17-H-S-A	Long Island University B	?	94102146
NY	NYC	YPC-FN-17G-17-C-S-A	New York Life A	N	93102126
NY	NYC	YPC-FN-17G-17-C-S-A	New York Life B	N	93102126
NY	NYC	YPC-FN-17G-17-C-S-A	New York Life C	N	93102126
NY	NYC	YPC-FN-17G-17-C-S-A	New York Life D	N	93102126
NY	Jamaica	YPC-DF-13S	New York Telephone	N	92803855
NY	Jamaica	YPC-DF-13S	New York Telephone	N	92803855
NY	Dansville	YPC-ST-16GL	Nicolas Noyes	N	92811443
NY	NY	YPC-FD-13SC-17-H-S	NYCHA - Police HQ 'A'	?	95102394
NY	NY	YPC-FD-13SC-17-H-S	NYCHA Police HQ 'B'	?	95102394
NY	New York	YPC-ST-19GL-46-C-S	Nymex	?	95102448
NY		YPC-FD-12SC-17-H-X-A	NYU Residence Hall	Y	95102384
NY	Pleasantville	YPC-FN-14S-17-S-S-B	Pace University	Y	95105009
NY	New York	YPC-FN-17G-17-C-S	Payson House A	?	95102404
NY	New York	YPC-FN-17G-17-C-S	Payson House B	?	95102404
NY	New York	YPC-ST-21G-46-C-A-B	Penn Plaza A	Y	96102561
NY	NEW YORK	YPC-FD-17G-46-H-A	PENN STATION	N	91803479
NY	NEW YORK	YPC-FD-17G-46-H-A	PENN STATION	N	91803479

State	Location	Model #	Project Name	Factory Installed	
				PTI Valve *	York Order #
NY	Queens	YPC-FN-16G-17-S-A-A	Queens Blvd. Ext. Care	N	93102127
NY	Smithtown	YPC-FN-14SC-46-C-S	Smithtown High School	?	95102339
NY	Deer Park	YPC-FN-13S-17-S-S-B	St. Johnland Nursing Home	Y	94102143
NY	New York	YPC-FD-16G-17-S-A	St. Tropaz	N	91803481
NY	New York	YPC-FD-16G-17-S-A	St. Tropaz	N	91803481
NY	Long Island City	YPC-FN-13S-17-H-A-B	Sunset Park Courthouse	Y	94102224
NY	NYC	YPC-ST-20G-46-C-A	Teachers A	N	92803726
NY	NYC	YPC-ST-20G-46-C-A	Teachers B	N	92803727
NY		YPC-FN-16G-17-C-A	Touro College	N	92803676
NY	Flatbush	YPC-FD-13S-17-H-S-A	Touro College A	?	93102130
NY	Flatbush	YPC-FD-13S-17-H-S-A	Touro College B	?	93102130
NY	NYC	YPC-FX-17G-46-H-A	U.S. Air	N	92803002
NY	Bronx	YPC-FN-16G-17-C-S	Union Hospital	N	92803772
NY	New York	YPC-FN-17G-17-C-A	Victory Memorial Hospital	N	92102877
NY	White Plains	YPC-FN-16G-46-C-S-B	White Plains Hospital A	Y	94102833
NY	White Plains	YPC-FN-16G-46-C-S-B	White Plains Hospital B	Y	94102833
NY	NYC	YPC-FD-17G-46-H-S	Wychkoff A	N	91803460
NY	Chazy	YPC-ST-19G-46-C-B-B	Wyeth-Ayerst Laboratories A	Y	94246512
NY	Chazy	YPC-ST-19G-46-C-B-B	Wyeth-Ayerst Laboratories B	Y	94246512
NY	New York	YPC-FD-12SC-17-H-A	Wyndam House	Y	95102263
OH	Cincinnati	YPC-FN-13S-46-S-S-A	Lagos & Lagos	?	94132122
OH	Canton	YPC-FN-15S-46-S-S-B	Montgomery Wards	Y	94131117
OH	Chillicothe	YPC-FN-13S-46-S-S-A	Pickway-Ross School	Y	94132141
OH	Painesville	YPC-ST-15GL	Ricerca	N	92903551
OH	Painesville	YPC-ST-15GL	Ricerca	N	92903551
OH	Toledo	YPC-FN-14S-46-S-S-A	Toledo Museum of Art	N	93133110
OH	Wright Patterson AFB	YPC-FN-12SC-46-H-S	Wright Patterson AFB	Y	95132205
OK	Oklahoma City	YPC-ST-21G-46-C-A	AT&T #1	N	92949043
OK	Oklahoma City	YPC-ST-21G-46-C-A	AT&T #2	N	92949044
OK	Oklahoma City	YPC-ST-21G-46-C-A	AT&T #3	N	92949045
OK	Oklahoma City	YPC-ST-21G-46-C-A	AT&T #4	N	92949046
OK	Oklahoma City	YPC-ST-19GL-46-C-A	St. Anthony's Hospital 'A'	?	95152274
OK	Oklahoma City	YPC-ST-19GL-46-C-A	St. Anthony's Hospital 'B'	?	95152274
OK	Tulsa	YPC-DF-11SL	Trinity Episcopal	N	92922185
OK	Tulsa	YPC-FN-17G-46-H-X-A	University Center Tulsa A	N	93217102
OK	Tulsa	YPC-FN-17G-46-H-X-A	University Center Tulsa B	N	93217102
ONT		YPC-ST-20G-46-C-A	Ford Canada-Chiller 2	N	93407426
ONT	Windsor	YPC-ST-19G-46-C-A-B	Ford Windsor #1	Y	95133237
ONT		YPC-ST-21G-46-C-X	GM Canada	N	92407360
ONT		YPC-ST-21G-46-C-X	GM Transmission	N	92407361
ONT	Niagara Falls	YPC-FN-13S-17-S-A-B	Ministry of Culture A	Y	94407545
ONT	Niagara Falls	YPC-FN-13S-17-S-A-B	Ministry of Culture B	Y	94407545
PA	Leisening	YPC-FN-13S-46-H-A	Belvatone Systems	Y	95201051
PA	Coatsville	YPC-FN-13SC-46-H-S	Coatsville School District A	?	95111309
PA	Coatsville	YPC-FN-13SC-46-H-S	Coatsville School District B	Y	95111309
PA	Philadelphia	YPC-FN-20G-46-H-A	Criminal Justice Center 01A	N	93111073
PA	Philadelphia	YPC-FN-20G-46-H-A	Criminal Justice Center 01B	N	93111073
PA	Philadelphia	YPC-FN-20G-46-H-A	Criminal Justice Center 01C	N	93111073
PA	Philadelphia	YPC-FN-20G-46-C-A	Criminal Justice Center 06A	N	93111073
PA	Philadelphia	YPC-FN-20G-46-C-A	Criminal Justice Center 06B	N	93111073
PA	Philadelphia	YPC-FN-20G-46-C-A	Criminal Justice Center 06C	N	93111073
PA	Doylestown	YPC-FD-18G-46-C-A	Doylestown Hospital	N	93111095
PA	West Chester	YPC-DF-12S	E.O.Bull Computer Center	N	92805903
PA	Lewisburg	YPC-FD-16G-46-H-S-A	Evangelical Community Hospital	N	93114030
PA	Philadelphia	YPC-DF-13S	Highland Park School	N	92805111
PA	Coatsville	YPC-FD-14SC-46-H-S	Kings Highway Elem.	Y	96111580
PA	Philadelphia	YPC-FN-14SC-46-S-S-B	Kurz-Hastings A	Y	95111366
PA	Philadelphia	YPC-FN-14SC-46-S-S-B	Kurz-Hastings B	Y	95111366
PA	Westpoint	YPC-ST-22G-46-C-A	Merck	N	91804230
PA	Westpoint	YPC-ST-22G-46-C-A	Merck	N	91804230

State	Location	Model #	Project Name	Factory Installed	
				PTI Valve *	York Order #
PA	Westpoint	YPC-ST-22G-46-C-X	Merck	N	92804290
PA	Riverside	YPC-ST-21G-46-C-S-A	Merck	N	94106016
PA	Westpoint	YPC-ST-22G-46-C-X	Merck Bldg 80	N	92804250
PA	Allentown	YPC-FN-17G-17-C-S	Nestle Dist. Company A	N	93111041
PA	Allentown	YPC-FN-17G-17-C-S	Nestle Dist. Company B	N	93111041
PA	Springhouse	YPC-ST-18G-46-C-X-B	Ortho McNeil YPC	Y	94111172
PA	Philadelphia	YPC-FD-15S-46-C-S-B	PCI Packaging Coordinators A	Y	94111252
PA	Philadelphia	YPC-FD-15S-46-H-S-B	PCI Packaging Coordinators B	Y	94111252
PA	Philadelphia	YPC-FN-16G-46-H-A-B	Philadelphia Osteopathic A	Y	94111208
PA	Philadelphia	YPC-FN-16G-46-H-A-B	Philadelphia Osteopathic B	Y	94111208
PA	Swarthmore	YPC-ST-18G-46-C-A-B	Swarthmore College	Y	94111246
PA	Upper Darby	YPC-FD-18G-46-H-A-A	Upper Darby High School A	N	94111135
PA	Upper Darby	YPC-FD-18G-46-H-A-A	Upper Darby High School B	N	94111135
QUE	Montreal	YPC-FN-14S-46-C-S-A	Edifice Environnement	Y	94406091
QUE	Montreal	YPC-FN-14S-46-H-X-A	Gaz Metropolitan	Y	93406046
QUE	Noranda	YPC-FN-13S-46-S-S-B	UQ Rouyn	Y	95406130
RI	Providence	YPC-FN-12SC-17-S-A-B	URI Coastal	Y	95103233
SC	Edgefield	YPC-FD-19GL-17-H-S	Edgefield Prison	?	95125031
TX	Allen	YPC-FN-13S-46-H-A-A	Allen Middle School A	Y	93152009
TX	Allen	YPC-FN-13S-46-H-A-A	Allen Middle School B	Y	93152009
TX	McKenney	YPC-FN-17G-46-C-A	Collin County A	N	92915440
TX	McKenney	YPC-FN-17G-46-C-A	Collin County B	N	92915440
TX	Dallas	YPC-ST-20G	Dallas County Co-Generation	N	92915428
TX	Grand Prairie	YPC-FN-15S-46-H-S-B	Dallas/Fort Worth Medical Ctr.	Y	94152209
TX	Mesquite	YPC-FN-18G-46-C-X-A	Eastfield College	Y	94152167
TX	RICHMOND	YPC-FD-18G-46-H-A	JESTER IV PSYCHIATRIC	N	91928287
TX	RICHMOND	YPC-FD-18G-46-H-A	JESTER IV PSYCHIATRIC	N	91928287
TX	Refuge	YPC-DF-12S	Memorial Hospital	N	91916716
TX	Irving	YPC-FN-17G-46-C-A	Northlake College A	N	93152110
TX	Irving	YPC-FN-17G-46-C-A	Northlake College B	N	93152110
TX	Dallas	YPC-FN-16G-46-C-A-B	Parker College	Y	95152239
TX	Dallas	YPC-FN-13S-46-H-S-A	Paul Quinn College Adm. Bldg.	?	94152106
TX		YPC-FN-16G-46-H-S	Rockwall A	N	92915371
TX		YPC-FN-16G-46-H-S	Rockwall B	N	92915371
TX	Houston	YPC-ST-22G-46-C-A	Shell Development Company	N	92916070
TX	San Marcos	YPC-ST-22G-46-C-X	Southwest Texas State Univ.	Y	96151278
TX	Lubbock	YPC-FD-18G-46-H-A-A	TDCJ Facility A	N	94210302
TX	Lubbock	YPC-FD-18G-46-H-A-A	TDCJ Facility B	N	94210302
TX	Denton	YPC-FN-13S-17-H-S	Thomas Rivera Elementary	N	92915535
TX	San Antonio	YPC-ST-19G-46-C-A-B	Wilford Hall Medical Center A	N	94142512
TX	San Antonio	YPC-ST-20G-46-C-A-A	Wilford Hall Medical Center B	N	94142512
WI	Wausau	YPC-FN-15S-46-H-S-B	North Central Health Care	Y	95240751
		YPC-ST-18G-50-C-A	Abbott Labs - Italy	Y	95953002
		YPC-ST-19GL	Alcatel	?	93954055
		YPC-DF-11SL	American College of Surgeons	N	92901456
	London	YPC-FN-12SC-50-H-A	Brookhouse Apartments A	Y	95954257
	London	YPC-FN-12SC-50-H-A	Brookhouse Apartments B	Y	95954257
	Cairo	YPC-FD-12SC-50-C-S-B	Cairo Information Center	Y	95970447
		YPC-FN-16G-50-H-S	Cartotacnica Rifernate	Y	95954223
		YPC-DF-12S	Cathedral Square A	N	92407306
		YPC-DF-12S	Cathedral Square B	N	92407306
		YPC-DF-12S	Cathedral Square C	N	92407306
		YPC-FN-16G-17-H-A	Cherry Hill	N	92805959
		YPC-FN-14S-50-S-S-B	Commerciale Ancona	Y	95954193
	Berlin	YPC-FN-13S-50-H-A-B	Druckhaus Friedrichshain	Y	95944151
	Berlin	YPC-FN-13S-50-H-A-B	Druckhaus Friedrichshain A	Y	94944107
	Berlin	YPC-FN-13S-50-H-A-B	Druckhaus Friedrichshain B	Y	94944107
	Berlin	YPC-FN-13S-50-H-A-B	Druckhaus Friedrichshain C	Y	94944107
		YPC-FN-15S-50-C-S-B	EKZ Dormagen	?	94944071
		YPC-FN-16G-50-H-A-B	Fiat Iveco-Stura	Y	94954164

State	Location	Model #	Project Name	Factory Installed	
				PTI Valve *	York Order #
		YPC-ST-18G-46-C-S	Ford Canada-Chiller 6	N	92407404
		YPC-ST-20G-46-C-A	Ford Canada A "Chiller3"	N	92407403
		YPC-ST-20G-46-C-A	Ford Canada B "Chiller4"	N	92407403
		YPC-ST-20G-46-C-A	Ford Canada C "Chiller5"	N	92407403
		YPC-ST-20G-46-C-A	Ford Canada D "Chiller1"	N	92407403
	Munich	YPC-FN-13S-50-H-S-B	Fraunhofer Munich	Y	95944128
		YPC-FN-16G-50-H-C	Hertie Dresden A	N	93944012
	Dresden	YPC-FN-18G-50-H-A-A	Hertie Dresden B	N	93944013
	Brussels	YPC-FN-16S-50-C-S-B	ILEAS Brussels A	Y	96954281
	Turin	YPC-FN-16G-50-S-A-A	IRCC Candiolo	?	94954109
		YPC-FD-13S-28-H-S-B	ISSSTE Cerralvo	Y	94991208
		YPC-FN-18G-50-H-A	IVECO	Y	96953009
		YPC-ST-16SL-50-C-S-B	Janssen-Cilag	Y	96953012
		YPC-ST-16SL-50-C-S	Janssen-Cilag	Y	96953016
		YPC-FN-16G-50-H-A	Karstadt	?	93944004
		YPC-FN-18S-50-H-S-B	Karstadt - A	Y	96944230
		YPC-FN-18S-50-H-S-B	Karstadt B	Y	96944230
		YPC-FN-18S-50-H-S-B	Karstadt C	Y	96944230
	Lubeck	YPC-FN-20G-50-H-A-B	Karstadt Lubeck	?	93944005
	Brasilia	YPC-ST-19GL-46-C-X-B	Lab Roche	Y	95922149
		YPC-FN-17G-50-H-A-B	LBS Potsdam	Y	94944093
		YPC-ST-18S-46-C-S-B	Merck, Sharp & Dohme	Y	95989225
	Madureira	YPC-ST-19GL-46-C-X-B	Norte Shopping	Y	95922155
		YPC-FN-14SC-50-H-S	OSP S. Vito Tagliamento	Y	96953015
		YPC-FN-14SC-50-H-S	OSP Vito Tagliamento	Y	96953015
		YPC-FN-16G-50-H-A	QCS Heathrow Airport A	?	94954191
		YPC-FN-16G-50-H-A	QCS Heathrow Airport B	?	94954191
		YPC-DF-11S	Readers Digest	N	92803966
	Berlin	YPC-ST-19GL-50-C-C-B	Schering Berlin A	Y	95944132
	Berlin	YPC-ST-19GL-50-C-C-B	Schering Berlin B	Y	95944132
		YPC-FN-16G-50-S-A	Schering Project	N	92114108
		YPC-FN-12SC-17-C-S	Senior Quarters	Y	95102411
		YPC-DF-13S	SGI Temple	N	93102001
	Hong Kong		Shanghai Times Square	?	95912062
		YPC-DF-14S-50-C-S-A	Socim C & A	?	94954078
		YPC-FN-13S-50-H-S-A	Stadtsparkasse Trier	?	93944029
		YPC-FD-17G-50-S-A	State Life A	Y	95970562
		YPC-FD-17G-50-S-A	State Life B	Y	95970562
		YPC-FN-16G-50-H-S-B	TBA Heathrow 1A	Y	94954189
		YPC-FN-16G-50-H-S-B	TBA Heathrow 2A	Y	94954189
		YPC-FN-16G-50-H-S-B	TBA Heathrow 2B	Y	94954189
		YPC-FN-16G-50-H-S-B	TBA Heathrow 2C	Y	94954189
		YPC-FD-18G-46-H-S	Thorton Hospital	N	91931078
	Lahore	YPC-FN-16G	U.S. Aid #1	N	92117521
	Lahore	YPC-FN-16G	U.S. Aid #2	N	92117521
	Brussels	YPC-FN-16G-50-C-S-B	Unilever Belgium	Y	94954176
		YPC-FN-15S-50-H-S-B	Viscount Heathrow 1	?	94954190
		YPC-FN-15S-50-H-S-B	Viscount Heathrow 2	?	94954190
		YPC-FN-13S-50-H-A-B	Volksbank	Y	94944096
		YPC-FD-17G-46-H-S	Wyckhoff B	N	91803461
	Brussels	YPC-FN-16S-50-C-S-B		Y	96954281

* PTI Valve = Pressure Transducer Isolation Valve

Even though the presence of the pressure transducer isolation valve may be indicated, visual confirmation is recommended.

Smart Purge (09 EPROM) Field Retrofit Instructions

The 09 EPROM incorporates some long awaited features into its programming. Two of the most exciting features are SmartPurge™ (AutoPurge) and a Crystallization Cutout Safety Feature.

SmartPurge™ - With SmartPurge™, manual purging during normal operation is no longer necessary. Non-condensables accumulate in the purge chamber during the run cycle. When the pressure in the purge chamber reaches 60 mmHg, the purge pump is turned on, followed by subsequent opening of the SmartPurge™ automatic valves. The pressure in the tank is reduced to 30mmHg before the valves are closed and the purge pump is turned back off.

Pages 15 and 16 depict purge systems for both the S and G series units, with and without autopurge.

Quantity of purges is automatically monitored: On completion of the above cycle, an internal counter adds one to its previous value. If the quantity of purges exceeds an unacceptable amount during a seven day period, a warning is displayed indicating an excess purge condition. If this happens, either a leak has developed and/or the internal chemistry is not to specifications. The customer should call York immediately to troubleshoot the problem, thus eliminating any unnecessary internal corrosion or system down time.

Crystallization Cutout Safety Feature - This feature provides added protection against crystallization during the run cycle. The strong solution concentration leaving the high temperature generator is constantly calculated and if this value exceeds 65.5%, the unit loading will be reduced in the hopes of lowering this concentration. If after a reduction in input, the concentration is still excessive, the unit will cycle off on a safety shut down.

1. Hardware Installation Overview

The new EPROM (A.01F.09) release for the Micro Panel contains many new features, some of which require hardware addition and some modification to the unit. The modifications to the unit aside from installing this new EPROM are as follows:

Note: Items A, B, and C require welding to the shell. A

slight positive pressure of nitrogen or argon must be present in the unit at all times during welding.

A. An opening must be made in the purge tank for the addition of an isolation valve (diaphragm type). This will require taking the unit out of service, pressurizing it to atmospheric pressure, installing the valve and then leak checking and re-evacuating it again. (see the specific task instructions for the detailed procedure).

Note: This step may be eliminated if the purge tank transducer isolation valve was Factory installed. This valve is installed on all model S and later model G-units.

This valve is located on the purge tank. To determine if it is present on your unit, refer to drawing number M1 for models 16G-21G and M2 for models 22G-22GL.

B. A thermowell must also be installed between valve VA and the 2nd stage generator tube side outlet box. This well is for the new thermistor (RT12) which senses the condensate temperature leaving the 2nd stage generator. This thermistor must be installed if the Crystallization Cutout Safety Feature is to function.

C. A pressure transducer and two automatic valves must be installed on the purge piping. A bracket must be welded to the shell to support the autopurge piping assembly (Refer to drawings M3 and M4).

D. A pressure transducer must be installed on the purge tank isolation valve that was either Factory installed or installed in Step A.

E. Modifications may require replacement of the existing I/O expansion board with an updated board.

F. If the existing EPROM is an A01F06 or earlier, the chilled water flow switch wiring will have to be changed.

2. Parts and Materials Needed and Determination of Scope of Work

A. An 09 EPROM retrofit kit is available at the Baltimore Parts Warehouse (Part# 325-32967-000). It contains all components necessary to perform the field retrofit minus service tools and some bulk materials.

Table 1 : Components Contained in 09 EPROM (Smart Purge) Retrofit Kit

Item	Quantity	Description	York Part Number
1	2	Pressure Transducer	025-29907-002
2	1	Thermistor (3K), LTG Condensate Temperature	025-29964-000
3	1	Electrically Actuated Purge Ball Valve	022-09562-000
4	1	Purge Solenoid Valve	022-09563-000
5	1	Housing Plug (P8)	025-28382-000
6	1	Housing Plug (P17)	025-28385-000
7	1	EPROM - (A.01.F.09)	031-01669-002
8	2	Suppressors for Purge Solenoid and Ball Valve	031-00808-000
9	1	I/O Expansion Board	031-01301-001
10	1	Electrical Box (JB6) - 2X4	025-01146-000
11	1	2X4 Electrical Box Cover	025-01732-000
12	1	1/2" Chase Nipple	025-05806-000
13	2	Locknut	025-05701-000
14	8	Contact, Socket	025-28386-000
15	3	Insulated Spring Spade	025-19407-000
16	2	Connector	025-28954-000
17	1	Connector	025-28951-000
18	8	Collar	025-28950-000
19	8	Contact, Receptacle	025-28952-000
20	1	3/8" Straight Connector for Flex Conduit	025-06678-000
21	3	3/8" 90° Connector for Flex Conduit	025-08199-000
22	2	1/2" Flange Weld Slip-On	023-10770-000
23	4	Screw Cap Hex. 5/8"-11UNC	021-02794-000
24	4	Nut Hex 5/8"-11UNC	021-00495-000
25	4	LockWasher Hel SPG 5/8" Reg	021-05273-000
26	1	Gasket Neoprene 1-7/8" OD	075-23414-000
27	2	Screw Cap Hex 1/4"-20 UNC	021-01406-000
28	2	Nut Hex 1/4" - 20 UNC	021-00450-000
29	2	Washer Plain 9/32" ID	021-01225-000
30	2	LockWasher Hel SPG 1/4" Reg	021-05267-000
31	1	Coupling, 1/4" FPT - Butt Weld	075-14528-000
32	1	1/2" Elbow - Long Radius Butt Weld	075-14526-000
33	1	Tee - 1/2" Weld SCH 40	023-10743-000
34	1	Wiring Label - Direct Fired Models	035-11951-000
35	1	Wiring Label - Steam Units	035-11952-000
36	1 Set	Retrofit Instructions	-
37	1	Warning Sticker - Auto Purge Pump Operation	075-23415-000
38	1	MicroPanel Operations Manual (Form 155.17-O2 (12/96))	-

Table 2: Pipe and fittings, tools and misc. items necessary for unit modification: The following list of material and tools should be on hand prior to beginning the modification.

Item	Qty	Description	York Part Number
1	1	Hole Saw, 1/2 inch	†
2	1	TIG Welding Equipment	-
3	1	Loctite Thread Cleaner 7070	013-02899-000
4	1	Loctite Primer N (7649)	013-01753-000
5	1	Loctite Thread Sealant 567	013-02280-000
6	‡‡	Nitrogen or Argon Tanks w/ Low Press Regulator	-
7	1	Vacuum Sealant, 4 oz.	013-02882-003 ‡
8	-	Rupture Disk Gasket Kit (6 inch) for G units	026-33819-000 ‡
9	-	Rupture Disk Gasket Kit (4 inch) for S units	026-33818-000 ‡
10	1	Valve, Diaphragm, socket weld	022-08869-052 †
11	1	Elbow, 1/2 inch, long radius (2 needed for 22G units)	075-14526-000 †
12	1	Coupling, 1/4 inch FPT -Butt Weld	075-14528-000 †
13	*	Paint, York Carribbean Blue	013-01835-000
14	1	AMP Watertite Pin Tool	755262-1 (Amp P/N)
15	1	AMP Tool - Universal Mate and Lock	755331-1 (AMP P/N)
16	1	Buchanan Tool	C-24 (Buchanan P/N)
17	3 ft	Pipe, 1/2 inch, Sch. 40 black (clean)	-
18	5"	Pipe, 3/8", Sch. 40 black (clean) - Refer to Dwgs M5 and M6	††
19	‡‡	2 wire shielded cable (Priced per foot)	025-28701-002
20	‡‡	3 wire shielded cable (Priced per Foot)	025-28701-003
21	‡‡	Misc. wire connectors, ties and supports.	-

Notes:

† Components required only if purge tank isolation valve needs to be installed. Refer to Drawing Numbers M1 or M2 and Step 1 of this retrofit procedure.

†† Components required if thermowell for RT12 needs to be installed (Refer to Drawing M5 and M6).

‡ For carbon disk quantity, refer to Table 3. Part numbers 026-33819-000 and 026-33818-000 contain enough gaskets for one rupture disk. **Not required if rupture disk is the new metal (inconel) type.**

‡‡ Quantity to be determined in field.

The kit contains all items listed in Table 1.

B. Items listed in Table 2 must be on-hand prior to performing this modification. Some components may not be needed depending on existing unit conditions. A visit to the job site will be necessary to determine the actual scope of work and field supplied components needed. Refer to items 1 through 4 below.

1. Has a purge tank transducer isolation valve been installed on the purge tank? All model S units are equipped with this valve. Refer to drawings M1 and M2 to determine if this valve is installed on model G units. If the valve is not present, install assembly as shown in the applicable drawing (M1 or M2) and Step A of the installation instructions.

Field supplied components needed for the addition of this valve assembly are marked with an † in Table 2.

2. Has a thermowell been installed between the low temperature generator tube side outlet box and valve VA? Refer to drawing M5 for thermowell location. A thermowell may have been installed at the Factory downstream of VA going to the condenser. **DO NOT USE THIS WELL.** If no thermowell was installed or if it was installed downstream of VA, install one as shown in Drawing M5. The thermowell can be manufactured using Drawing M6.

Field supplied components required for the addition of this thermowell are marked with an †† in Table 2.

3. What type of rupture disk is installed on the unit? Carbon or Metal?

Machines equipped with carbon rupture disk(s) will have to have their gaskets replaced after leak checking. Those equipped with the new metal rupture disk, do not have to be removed for pressure testing.

Materials required to remove and re-install carbon rupture disks are marked with an ‡ in Table 2. Table 3 lists the quantity of disks located on each model unit.

4. What version of EPROM is presently on the micro-board? If the EPROM version is an A01f06 or earlier, the chilled water flow switch wiring will have to be modified. This step doesn't require additional components and should only take about a half hour to perform.

Table 3 Carbon Rupture Disk Usage

Model Number	Disk Size	Quantity
YPC-16G-19GL	6"	1
YPC-20G-22GL	6"	2
YPC-12SC-15S	4"	1

3. Pre-Installation Requirements

This Retrofit Procedure requires taking the unit out of service for at least 24 hours. In most cases, the welding and leak checking could be done during normal working hours the first day although the earlier the start the better. The unit can then be left to evacuate overnight. **DO NOT START THIS PROCEDURE** unless sufficient time is available to complete all welding/leak checking so that unit evacuation is begun at the termination of work.

All estimated labor times below are for the addition of all components. These times will be reduced if certain components have been Factory installed.

Day 1: (20 man hours including welder)

a. A welder, experienced in Tig Welding Procedures, will be required. Refer to Section 5 of these instructions and drawings M1 - M6 for welding scope of work. The welder should read the ParaFlow Welding Procedure Manual (Form 155.17-M3) before he arrives at the job site.

b. Sections 5A - 5F should be performed. The unit will then be left to evacuate overnight. Determine manpower necessary to finish these sections in this time period.

Day 2: (16 man hours)

a. Electrical wiring (Sections 5G-5H) should be completed.

b. Final Retrofit Tasks (Section 5I) should be finished.

c. The machine should be put back on line and all operational check-outs should be performed. Hot purging and purging during operation will be required. All safety and operational tests (Section 5J) should be performed before the unit is left running unattended. All work not performed on day 2 should be finished on day 3.

Day 3: (8 man hours)

- a. Finish work from day 2.
- b. The machine should be monitored to make sure it is purging properly and is not in any danger of tripping on any of its safety devices.
- c. Train customer on new features of the 09 EPROM (Section 5K).

4. Pre-Retrofit Instructions

READ THE FOLLOWING INSTRUCTIONS COMPLETELY BEFORE PROCEEDING!

DO NOT LEAVE UNIT OPEN TO THE ATMOSPHERE AT ANY TIME!

ALL WELDING TO THE SHELL OR ADJOINING PIPING MUST BE DONE WITH THE UNIT IN A SLIGHT POSITIVE PRESSURE (< 1 PSI NITROGEN OR ARGON).

A. Evacuate the Purge Chamber - Purge unit purge chamber to at least 30 mm Hg, using the normal procedures.

B. Shut Machine Off - Shut the unit off by placing the Stop/Run/Stop-Reset Switch (Located on the Micropanel) to the Stop/Reset position. Allow unit to go through a complete dilution cycle after shutdown.

C. Shut Off and Lock Out Power - Electrically isolate the unit and properly tag all disconnects and safety interlocks.

D. Break the System Vacuum With Nitrogen or Argon-

1. Attach a low pressure regulator to either a nitrogen or argon tank.
2. Connect the low pressure side of the regulator with a hose to the purge piping of the ParaFlow unit at the manometer port (disconnect manometer).
3. Purge the line by opening the regulator slightly before tightening the connection at the unit.

DO NOT ALLOW AIR INTO THE UNIT.

4. Open the purge valves to the purge tank, absorber and condenser and slowly allow the unit pressure to increase to just slightly positive (less than 1 psi).

Maintain a slight positive pressure in the unit during the entire time it is open and whenever welding is being performed.

5. Retrofit Instructions

NOTE: BEFORE PERFORMING THIS RETROFIT, ALL OF THE PRE-RETROFIT ITEMS LISTED IN SECTION 4 MUST BE COMPLETED.

Use Drawings M1 to M6 and the following instructions to make the mechanical modifications to the unit.

- M1 - Purge Tank Isolation Valve (16G-21G).
- M2 - Purge Tank Isolation Valve (22G-22GL).
- M3 - SmartPurge™ Valves and Piping.
- M4 - Piping Support Bracket.
- M5 - Thermowell Location Diagram.
- M6 - Thermowell Detail.

A. Installation of Purge Tank Isolation Valve

Note: Units recently manufactured (both S and G series) may already have an isolation valve installed on the purge tank with a pipe plug in the end. This valve was installed in anticipation of the SmartPurge™ hardware. If this valve is installed, proceed to Step B.

1. Using the attached drawings (M1 and M2), layout the location for the hole to be cut in the purge tank.

Note: On smaller G series units, the purge tank is incorporated into the same box as the alcohol separator (Drawing M1).

2. Using the 1/2" hole saw, carefully cut a hole in the tank at the location shown in Drawing M1 or M2. The slight positive pressure in the unit should help prevent chips from falling into the tank.

WEAR YOUR SAFETY GOGGLES !

DO NOT USE OIL OF ANY KIND TO LUBRICATE THE HOLE SAW.

3. Follow the guidelines in the ParaFlow Welding Procedure Manual (Form 155-17-M3) and TIG weld the appropriate valve assembly (drawing number M1 or M2 (Detail A)) to the purge tank. The valve assembly should be oriented as shown in the appropriate drawing.

Note: Before welding valve, disassemble it and remove diaphragm.

4. After the valve is welded in place and has cooled down, re-assemble it.

5. Close valve by turning the handle clockwise until resistance is felt.

Note: Once the valve is closed, the pressure regulator may have to be turned back down to prevent over-pressurization of the machine. Adjust as needed to maintain a slight positive pressure.

B. Installation of Purge Tank Pressure Transducer

1. Ensure that the purge tank isolation valve is closed and remove the pipe plug where applicable.

Note: The pipe plug will be present on units already equipped with this valve.

2. Install the purge tank transducer.

Note: Use the Loctite cleaning, priming and sealing compounds listed in Table 2 when making up threads for transducer. **DO NOT SUBSTITUTE.** Carefully examine threads ahead of time for burrs or distorted threads. If threads are suspect, install another transducer.

3. Open Valve

C. Installation of Refrigerant Condensate Temperature Sensor (RT12) Thermowell.

1. Determine if a thermowell was installed at the Factory in the location shown in drawing M5.

2. Weld the thermowell onto the refrigerant line coming out of the Second Stage Generator tube side water box prior to valve VA. To avoid nuisance shutdowns, the thermowell must be installed as shown in Drawing M5.

Although the location may vary slightly from unit to

unit, it is important to locate the thermowell in an area of piping between the water box and VA so that a representative temperature is sensed by the thermowell.

On some S series models, the thermowell will have to be installed on the Second Stage Generator condensate box as shown in Drawing M5 (Optional Location). There is not enough room on the pipe, between the box and VA to install it.

Orient the thermowell so that clearance is available to insert the thermistor.

3. Fill well with heat transfer compound.

4. Insulate well with 1/2" fiberglass insulation.

D. Installation of Vacuum Pump Pressure Transducer, Purge Tank Solenoid Valve and Purge Pump Motorized Ball Valve Assembly

Refer to Drawing M3 for the standard auto-purge piping assembly.

Note: The piping length between the two valves may have to be changed depending on the model unit.

The following points should be strictly adhered to when installing the piping.

1. Use the Loctite cleaning, priming and sealing compounds listed in Table 2 when making up threaded joints. **DO NOT SUBSTITUTE.** Carefully examine threaded joints ahead of time for burrs or distorted threads. It is highly imperative that no leaks exist in this piping.

2. Solenoid valve must be installed with its coil in the vertical position and with the flow arrow (located on the body of the valve) pointing towards the the purge tank.

3. The motorized ball valve should be installed as shown in drawing number M3. The actuator/valve assembly must be supported to eliminate stress on the piping.

Note: Fabricate a support using the 1-1/4 X 1-1/4 X 1/4" field supplied angle iron and drawing number M4. Cut angle iron to length. A mitered cut may be necessary for certain G model units.

Use items 27-30 in Table 1 to bolt the ball valve to the fabricated support.

4. The Purge Pump Pressure Transducer must be installed in the vertical position.

5. Cut purge piping after VP5 and weld on field supplied flange. All other piping may be pre-assembled.

Note: If there is insufficient room, VP5 may be removed. Make sure that all other purge valves are closed before removing VP5.

Also take care to prevent dirt from entering the purge piping. If rust flakes are present in the existing piping from previous LiBr contamination, replace or clean the piping. Rust flakes or dirt will clog the solenoid valve and cause it to leak.

6. Use gasket and bolts supplied to mate the two flange halves (Items 23-26, Table 1).

7. Leak check new piping up to the motorized ball valve with soap solution and 12 psig of nitrogen or argon. Install a cap on the 1/2" nipple located on the down stream side of the ball valve (Refer to drawing M3 for details).

Note: Keep valve VP5 open and all other purge valves closed during the test. Increase pressure from nitrogen regulator through manometer port. Automatic purge valves must be electrically opened. Repair leaks as necessary.

8. Remove electrical connection to automatic purge valves.

9. After relieving pressure and removing test cap, reinstall check valve (Flapper Type P/N 022-09517-000) down stream of the motorized ball valve.

10. Attach hose from check valve to oil separator.

11. Replace flexible piping from oil separator to purge pump and check if piping is bubble tight by running the purge pump.

E. Leak Check Unit

1. Open VP5 if present.

2. If a carbon type rupture disk is present on the unit, remove and blank off or equalize the disk. The new style metal rupture disk should not be removed.

Note: Bleed nitrogen through unit when the rupture disk is removed. Before removing disk, make sure system is still in a slight positive pressure.

3. Open the purge valves to the purge tank, absorber and condenser and slowly allow the unit pressure to increase to the following:

Carbon rupture disk - removed and blanked off or equalized - 12 psig max.

New style metal rupture disk - installed - 9 psig max.

NOTE: DO NOT REMOVE METAL RUPTURE DISK. IT CANNOT BE RE-INSTALLED.

2. Leak check all welds and threaded joints using liquid soap-type leak check solution such as Big Blu or equivalent. Repair any leaks.

3. Release the leak check pressure until the unit's pressure is just slightly positive.

Steps 4 through 7 are applicable only if a carbon style rupture disk is installed on the unit.

4. Disconnect equalizing connection around rupture disk or re-install carbon rupture disk if removed prior to leak check.

Coat faces and rim of rupture disk with vacuum sealant and allow to dry before installing new gaskets. Install Belleville Disk Springs on rupture disk bolts. Re-install disk. Re-torque the rupture disk to 20-25 ft-lbs.

5. Increase nitrogen or argon pressure to unit to 5 psig maximum (rupture disk will burst at 7.0 ± 0.75 psig).

6. Leak check rupture disk using liquid soap-type leak check compound such as Big Blue or equivalent. Repair any leaks.

Figure 1. Cold Purging Saturation Chart

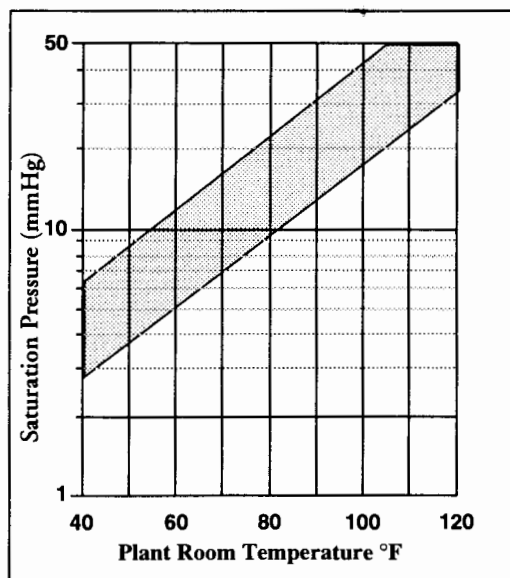

7. Release leak check pressure and continue to maintain a slight positive pressure.

F. Evacuate Unit Overnight

1. Close all manual purge valves.
2. Remove low pressure nitrogen or argon line going to manometer port after closing off cylinder if not already done.
3. Reconnect manometer line.

Use the Loctite cleaning, priming and sealing compounds listed in Table 2 when making up threads for manometer fittings. **DO NOT SUBSTITUTE.** Carefully examine threaded joints ahead of time for burrs or distorted threads. It is highly imperative that no leaks exist in this piping.

4. Install temporary power (120VAC) to both automatic purge valves.
5. Evacuate unit overnight through all purge valves simultaneously until unit is within the saturation pressure chart range shown in Figure 1.

BE SURE PURGE CHECK VALVE IS OPERABLE IF

LEAVING THE PURGE PUMP RUNNING AND UNATTENDED.

Note: Once the Automatic SmartPurge™ Valves have been installed, wired and remaining electrical tasks completed, the solenoids themselves will protect the unit in the case of a power failure.

G. Installation of Interconnecting Wiring and Sensor Cables

Once unit's pressure is within the saturation range as shown in Figure 1, close all purge valves and remove temporary power to automatic purge valves. Shut off vacuum pump.

Use Drawing Numbers W1 - W4 to make the wiring harnesses and to install the interconnecting wiring to the various devices.

W1 - Micro-board and I/O Expansion Board Connections.

W2 - Thermistor and Transducer Connections.

W3 - Relay Output Board Connections (Purge Valves 120 VAC).

W4 - Purge Valve Connections.

035-11952-000 - (Sheets 1-7) - System Wiring (Steam Fired)

035-11951-000 - (Sheets 1-6) - System Wiring (Gas/Oil Fired)

Caution: Disconnect and properly tag all electrical disconnects to the ParaFlow unit prior to working on the electrical devices.

FAILURE TO DO SO MAY CAUSE INJURY OR DEATH!

Low Voltage Connections

1. Replace the existing EPROM with the new one supplied in the retrofit kit.
 - a. Wash hands. Be sure they are free of oil, grease, and metal.
 - b. Locate the replacement EPROM in the kit.
 - c. Attach an anti-static wrist band and clip the other end to a panel ground screw or other

unpainted, grounded metal fastener in the Micropanel.

d. Using an extractor tool or small screw driver, carefully remove the EPROM from the U17 socket on the Microboard.

e. Being sure that the notch in the replacement EPROM is pointed up, carefully insert the pins in the U17 socket. It may be easier to insert the pins slightly on one side and then insert the other side. When all the pins are properly aligned with the socket, gently press the EPROM into place.

2. Check part number on existing I/O Expansion Board. If it differs from the 031-01301-001 part number, remove it and install new I/O board. For details on how to remove and reinstall the I/O Board see the ParaFlow Micro Panel Service Manual (155.17-M2)

3. Use one of the 4 small knockouts in the Micro Panel directly beneath the penetration where the existing shielded cables come through (Hole A), for both transducers and the new temperature sensor. A squeeze-type cable clamp should be used to pass all three cables into the Micro Panel. This hole is marked with the letter "F" on Drawing W1.

4. Fabricate and run a two wire shielded cable (P/N 025-28701-002) for 2nd Stage Generator Condensate Thermistor. Wire tie cable to unit supports when routing it. Be sure that the cable doesn't make contact with any hot surfaces along the way.

Make connections as follows:

MicroPanel

a. Plug P8 (025-28382-000) goes on the end that attaches to the I/O Expansion Boards receptacle J8. Use drawing W1 as a guide. Be sure to get the pins/sockets in the correct plug housing hole. Carefully inset housing plug P8 into Expansion Board receptacle J8.

b. Crimp on a supplied spade connector (025-19407-000) to the bare ground wire of the shielded cable. Attach connector to an existing ground screw adjacent to Hole A in the MicroPanel. Refer to Drawing W1 for details.

Thermistor (RT12)

a. Install connector (025-28951-000) on thermistor end of cable. Use drawing W2 as a guide. Be sure to get the receptacles/collars in the correct connector hole.

b. Snip off ground wire down to the insulation of the shielded cable.

c. Fill 2nd Stage Generator Leaving Refrigerant Temperature Thermowell with Thermal Mastic Heat Transfer Compound and insert the new thermistor. Insulate the thermowell area with at least two inches of fiber glass insulation.

Carefully push together both connectors. Wire tie cable to sensor as shown in drawing W2.

5. Run a three wire shielded cable (025-28701-003) for both the Purge Pump Pressure Transducer and the Purge Tank Pressure Transducer. Wire tie cables to unit supports when routing it. Be sure that the cables don't make contact with any hot surfaces along the way.

Note: It may be helpful to mark both ends of each cable.

Make connections as follows:

MicroPanel

a. Plug P17 (025-28385-000) goes on the end that attaches to the Micro Boards receptacle J17. Use drawing W1 as a guide.

Note: Both transducers connect to Plug P17.

Be sure to get the pins/sockets in the correct plug housing hole.

b. Carefully insert housing plug P17 into MicroBoard receptacle J17.

c. Crimp on a supplied spade connector (025-19407-000) to the bare ground wire of each shielded cable. Attach each connector to an existing ground screw adjacent to Hole A in the MicroPanel. Refer to Drawing W1 for details.

Pressure Transducers (PT3 and PT4)

- a. Install a connector (025-28954-000) on transducer end of both transducer cables. Use drawing W2 as a guide. Be sure to get the receptacles/collars in the correct connector hole.
- b. Snip off ground wire down to the insulation of both shielded cables.
- c. Carefully push together both connectors. Wire tie cable to transducers as shown in drawing W2.

6. Make 120VAC connections as detailed in drawings W3-W4 and the following instructions.

Purge Valve Connections

Caution: Disconnect and properly tag all electrical disconnects to the ParaFlow unit prior to working on the electrical devices.

- a. Choose a convenient knockout in the back of the MicroPanel to run wires. Marked as Hole G on drawing W3.
- b. Run 3/8" flexible conduit (Greenfield) from MicroBoard to JB3. Use appropriate connectors supplied with kit.
- c. Label and pull three 14 gauge wires (2,22, and 23) from the Micropanel, through the flexible conduit, to JB3.

Note: If 14-3 BX Cable is used, this step may be eliminated. Wires will already be present.

- d. Strip wires and make connections at Relay Output Board (Refer to Drawing W3).
- e. Run 3/8" flexible conduit (Greenfield) from JB3 to Motorized Ball Valve (Refer to Drawing W4). Use appropriate connectors supplied with kit.
- f. Use existing wires from motorized ball valve and run them through the flexible conduit to JB3.

Note: If wires from Motorized Ball Valve do not reach JB3, install an additional junction box at motorized valve and make connections.

g. Make valve connections to wires coming from Relay Board (refer to drawing W4).

Note: Suppressors must be installed across each valve as shown.

H. Chilled Water Flow Switch Wiring Modification (Necessary only if existing EPROM is Version 06 or lower).

Important: Please read over entire change before beginning work.

Summary of Change: Remove CHFLS from Safety Switch series configuration and reconnect to terminals 1 and 12 on the Micropanel digital input board as shown on the attached revised wiring diagrams (labels) 035-11951-000 (direct fired units) and 035-11952-000 (steam units). This allows power to be available to initiate a CHFLS safety switch opening following another safety shutdown.

How to make the Change:

WARNING : Open and lock out all electrical disconnects to the unit before proceeding. Failure to do so can result in INJURY or DEATH!

Micropanel

1. Open the Micropanel door.
2. At TB5, disconnect wire #25. Using a Buchanan ferrule with an insulator and a crimping tool, wire cap the bare end of the wire. Bend the capped wire end back on to the main body of the wire and securely wrap together with electrical tape. The capped end of the wire must be completely covered so there is no visible exposure. Coil any excess wire and wire tie to the back of the panel.
3. At TB5, re-label wire #24 as wire #1. Disconnect the wire and install at terminal #1 on TB2 of the Digital Input Board.
4. Obtain terminal block jumper supplied with the

Micropanel spare parts. Install the jumper at TB5, between terminal #s 24 and 25. If factory jumper can't be found, use a piece of wire.

5. Check all new connections to be sure they are secure and correct.

6. Close the Micropanel door.

CHFLS Wiring

1. Locate CHFLS and remove cover.

2. Currently, the wiring of the CHFLS will be in accordance with **Figure 2** when a York supplied CHFLS has been used. Depending on the unit model, the York supplied switch will either be from Watts Regulator P/N FS20 or McDonnell-Miller P/N FS-4W or FS-8W. Wire #24 will be connected to the common contact, wire #12 will be connected to the normally closed contact and wire #25 will be connected to the normally open contact.

Figure 2. Existing Wiring Configuration

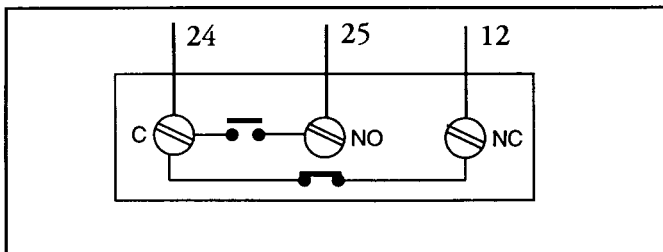

3. Re-label wire #24 at the Common Terminal as wire #1.

4. Disconnect wire #25 from the Normally Open Terminal. Cut off or remove the wire label. Using a Buchanan ferrule with an insulator and crimping tool, wire cap the bare end of the wire. Bend the capped wire end back on to the main body of the wire and securely wrap together with electrical tape. The capped end of the wire must be completely covered so there is no visible exposure.

5. Disconnect wire #12 from the Normally Closed Terminal. Reconnect wire #12 to the Normally Open Terminal where wire #25 was originally connected.

6. The final wiring of the CHFLS should be in accordance with **Figure 3**. Wire #1 is to be connected to

common terminal. There is to be no connection to the normally closed terminal and wire #12 is to be connected to the normally open terminal.

Figure 3. New Wiring Configuration

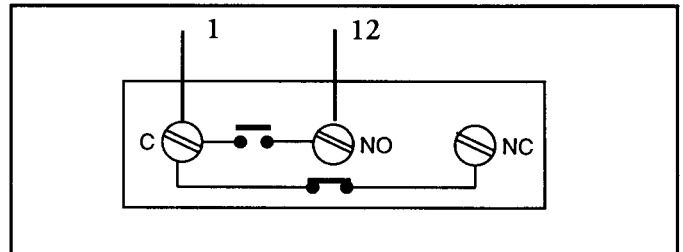

7. Check to be sure all new connections are secure and correct.

8. Replace the cover on the CHFLS.

9. Place the Micropanel Unit Switch into the Stop/Reset position and reconnect power to the unit by closing the Main Disconnect Switch in the Power Panel and also the locked out disconnect switches.

Testing the Wiring After the Change Prior to Chiller Operation :

1. With power restored, the unit must be tested to make sure that the CHFLS is connected correctly. Leaving the Unit Switch in the Stop/Reset position, clear all faults from the display by entering the Service Mode and depressing the Reset Key.

2. Remove power feeding the Chilled Water Pump Motor. Open Fused Disconnect Switch (or equivalent disconnect) or if available, place the Hand/Off/Auto Switch for the Chilled Water Pump Motor into the Off position.

3. Leaving power to the Chilled Water Pump Motor removed, go to the Micropanel. Press the Status Key. The message on the Micropanel should read;

NO MALFUNCTION DETECTED

4. With power to the Chilled Water Pump Motor still off, place the Unit Switch into the Start position. After thirty seconds the unit should indicate a safety shut-down.

5. With power to the Chilled Water Pump Motor still removed, press the Status Key again. The Micropanel should read;

[DAY] [TIME] CHILLED WATER FLOW SWITCH

The unit should no longer enter the Run Mode.

6. If the unit did not respond properly to the required testing, shut the unit down and disconnect power.

Place the Unit Switch into the Stop/Reset position and open the Main Disconnect Switch in the Power Panel.

WARNING: Open and lock out all electrical disconnects to the unit before proceeding. Failure to do so can result in **INJURY or DEATH!**

Recheck all new connections at the CHFLS and in the Micropanel. After the problem is corrected repeat the testing procedure.

7. If the unit responded correctly, place the appropriate wiring schematic in the micropanel door.

8. Restore power to the Chilled Water Pump Motor. Close Fused Disconnect Switch (or equivalent disconnect) or if available, place the Hand/Off/Auto Switch for the Chilled Water Pump Motor into the Hand or Auto position.

9. Close the Micropanel door. The unit is now ready for regular service. Discard old EPROM, and wiring schematics.

I. Perform Final Retrofit Tasks

1. Clean and re-paint piping and welds.
2. Following purging procedures as outlined in the ParaFlow Start-up Instruction Manual (Form 155-17-SU2) purge the unit and place it back in service.
3. Flush Vacuum Pump using Welch Oil Flush Procedure outlined in Green Letter (155-17 NM1 [SB17])
4. Replace vacuum pump oil.

J. Software Checkout and Setup

The following instructions assume that the installer has some previous knowledge of York MicroPanels. Service and operational information for the 09 EPROM is located in forms 155.17-M2 (1/97) and 155.17-O2 (12/96).

1. The following jumpers must be set as follows for the software and hardware to function properly.

I/O Expansion Board:

J14 - Solution Concentration Analyzer - Disable/Enable

Installed on Pins 1 and 2 - Solution concentration display and safety shutdown disabled.

Installed on Pins 2 and 3 - Solution concentration display and safety shutdown enabled.

JP1 - SmartPurge™ - Enable/Disable

Removed - Enable SmartPurge™
Installed - Disable SmartPurge™

2. Perform the following software operational checks:

a. Check out the operation of the purge valves using the manual purge function.

1. Enter the **Program Mode** using access code **9675**.

2. Press the **Manual Pump Key**.

“Purge Type = 1 (0=MAN;1=AUTO TANK)” is displayed.

3. Type 0 and press the **ENTER** key.

PROGRAM MODE, SELECT SETPOINT is displayed.

Press the **PROGRAM** key to exit Program Mode.

In manual purge operation, although the purge tank solenoid and purge pump ball valves are controlled automatically, the operator must manually operate the purge pump as before.

To start manual purge:

Press the **PUMP STATUS** key until **"PURGE PUMP - OFF - MANUAL PURGE"** is displayed.

Press the **MANUAL PUMP** key.

"PURGE PUMP - ON - MANUAL PURGE" is displayed.

The purge pump will start immediately. After two minutes, the purge tank solenoid valve (1SOL) and purge pump motorized ball valve (2SOL) will open.

Open VP5 and/or VP2 and evacuate the purge tank down to 30mmHG. Close purge valves.

To stop manual purge:

If necessary, Press **PUMP STATUS** key until **"PURGE PUMP - ON - MANUAL PURGE"** is displayed.

Press the **MANUAL PUMP** key.

If the pump has been running less than two minutes, (purge pump and tank automatic valves not yet opened), the purge pump is turned off and **"PURGE PUMP - OFF - MANUAL PURGE"** is displayed.

If the purge pump has been running for greater than two minutes, the two automatic valves are de-energized and the following message is displayed.

"PURGE PUMP VALVE CLOSING"

65 seconds after this message is displayed, the vacuum pump is turned off and **"PURGE PUMP - OFF - MANUAL PURGE"** is displayed.

Press the **DISPLAY HOLD** key to get back to the normal foreground message.

b. Check that the new pressure transducers read correctly. Compare to manometer on machine.

c. Check that the new temperature sensor reads correctly. Use infrared temperature scanner or thermometer.

d. Perform a Burner Calibration (on gas fired units). Refer to Form 155.17 - M2 (1/97-pp.66-68) for details.

Note: It may be necessary to recheck/adjust the maximum cooling or heating programmed value after this operation so that the correct firing rate is obtained for the respective high fire rate (Full Fire Mode Setpoint - Form 155.17 - M2 (1/97-p.68)).

e. **Reset all four purge counters to zero.**

Refer to Form 155.17 - M2 (1/97-p.62)) for details.

f. **Enable Generator Concentration Display.**

J14 of the I/O Expansion Board must be installed between pins 2 and 3.

1. Press and release the **UNLOAD** key.

2. Use the **Advance/Day Scroll** key until either of the following is displayed.

SHOW SOL'N CONCENTRATION = 0 (0=NO ;1=YES) or,

SHOW SOL'N CONCENTRATION = 1 (0=NO ;1=YES)

3. Using the **Entry** keys, Press **"1"** to enable the display.

4. Press the **Enter** key.

5. Press the **Access Code** key to return to the normal background message.

Note: Once the machine has been started and purged, it will be necessary to take a solution sample coming from the first stage generator (strong solution return) and compare it to the displayed concentration. If the values differ by more than 1/2%, RT12 may not have been installed in the correct location, is not insulated properly or is defective. Correct problem until actual concentration matches displayed concentration.

3. Place the purge into the Auto Mode making sure that the manual purge valves are positioned correctly; VP5 (if not removed) and VP2 open.

a. Enter the **Program Mode** using access code 9675.

b. Press the **Manual Pump Key**.

“**Purge Type = 1 (0=MAN;1=AUTO TANK)**” is displayed.

c. Type 1 and press the **ENTER** key.

“**OPEN VP2, CLOSE VP4, THEN PRESS THE ENTER KEY**” is displayed.

Note: VP5 should always be open during automatic operation.

Important !!! The manual valves must be adjusted before proceeding to the next step, since an immediate auto tank purge will occur if the tank pressure is greater than 60 mmHg.

Danger: The purge pump will now operate automatically. Make sure belt guard is in place.

d. Press the **ENTER** key.

e. Press the **PROGRAM** key to exit Program Mode.

4. Install the Warning Label that states the purge pump will start automatically (supplied).

K. Customer Training

1. Instruct customer personnel on the new features of unit operation.

If it is desired to connect an alarm or send a signal to a BAS system when a system warning occurs, the following dry contacts should be used.

Relay Output Board

TB4 - Terminals 89/90

2. The customer should be made aware that excessive purging may be required during the first week or so of operation after the retrofit. The excessive purge warning

will not occur until after 150 hours of unit operation. If the warning occurs after this time period, the customer should inform the installer and the following should be done.

a. Take a solution sample and send in to lab for analysis.

b. Make chemical adjustments as necessary.

c. If the warning reoccurs, an air leak may be present in the unit.

3. Give customer new 09 EPROM Operators Manual (Form 155.17-O2 12/96) supplied with kit.

All questions related to this retrofit should be directed to York Factory Service.

Important !!! Before leaving site, recheck torque on carbon rupture disk bolts (if removed for leak testing).

**G Series Unit Purge System
(without SmartPurge™)**

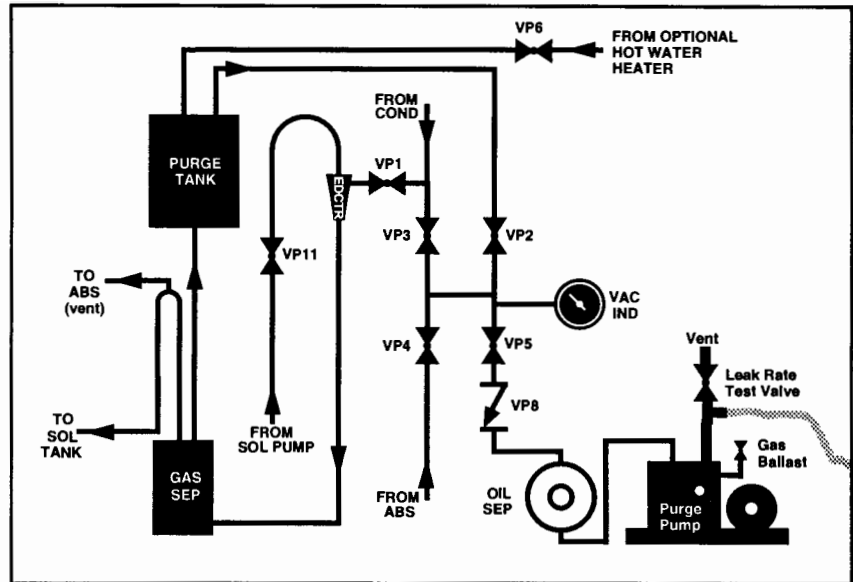

**G Series Unit Purge System With
SmartPurge™**

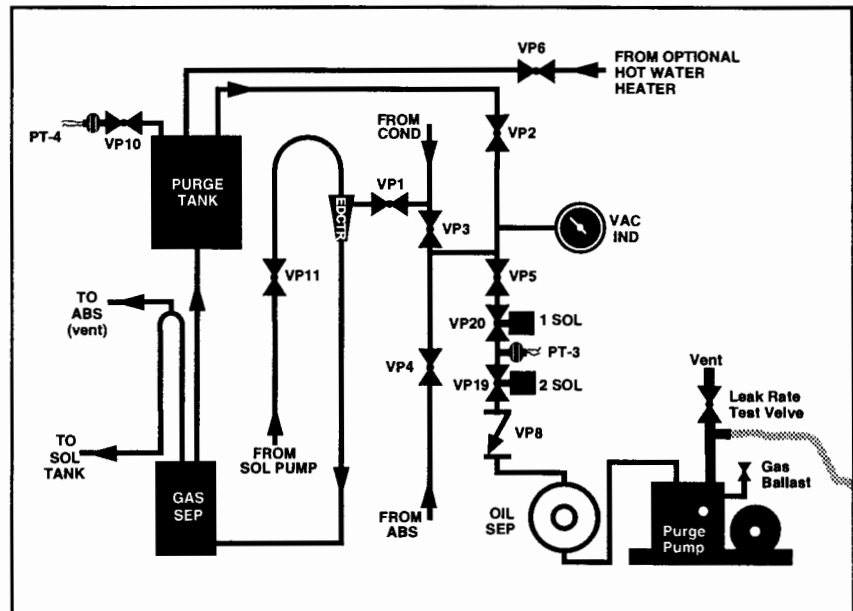

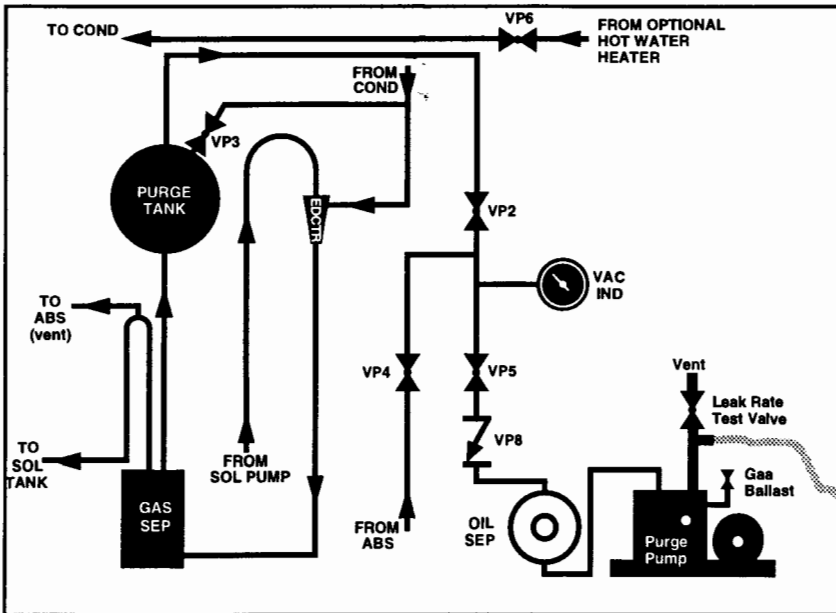

**S Series Unit Purge System
(without SmartPurge™)**

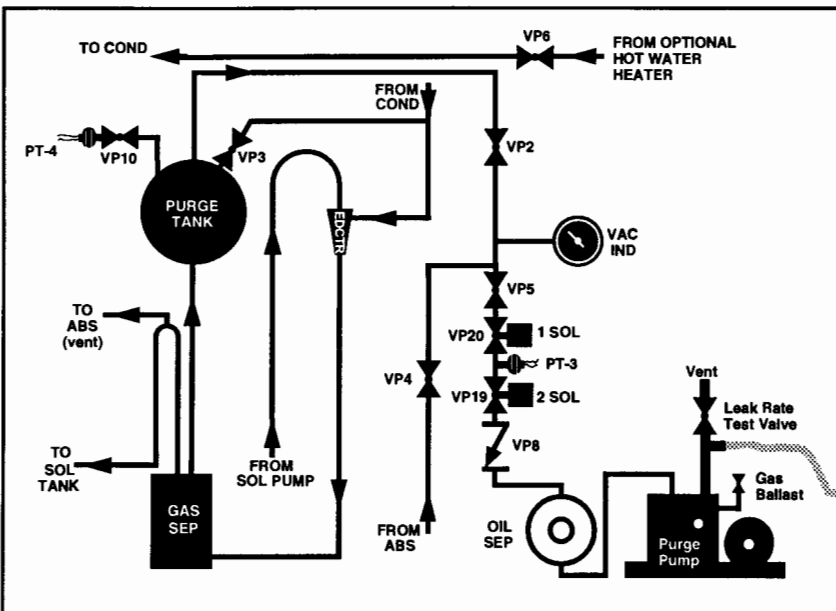

**S Series Unit Purge System
With SmartPurge™**

FIELD SUPPLIED COMPONENTS:

- A - 075-14528-000 - COUPLING 1/4" FPT
- B - FIELD SUPPLIED 1/2" SCH40 BLK PIPE - CUT TO LENGTH AND BEVEL ONE END.
- C - 022-08869-052 - 1/2" DIAPHRAGM VALVE SOCKET WELD.
- D - 075-14526-000 - 90 DEG. LONG RADIUS EL.

DETAIL A

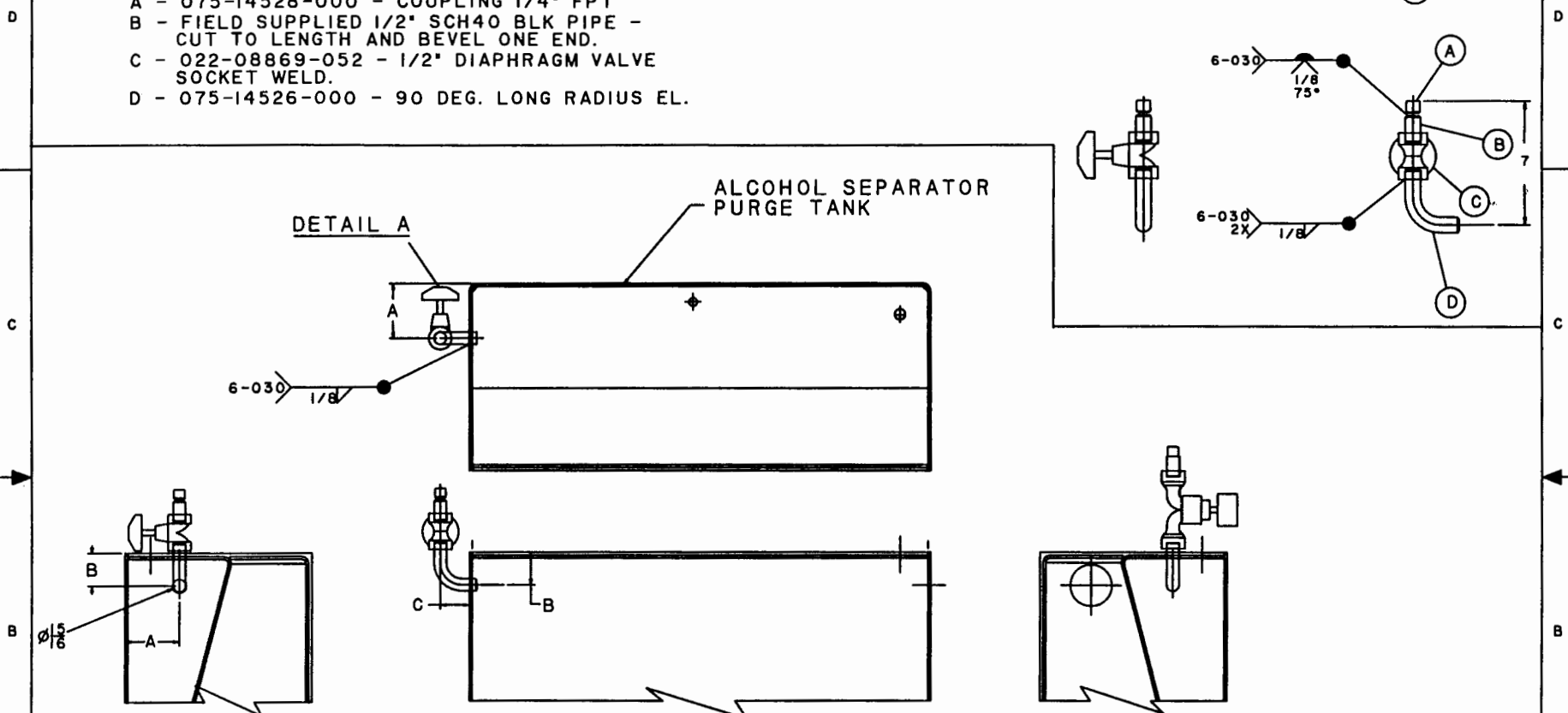

MODEL	A	B	C
16G,17G,18G,19GL,20G, & 21G	3-3/4	2-1/4	2
19G	4-1/2	2-1/4	2

NOTES:

1. IF VALVE ASSEMBLY IS NOT INSTALLED AS SHOWN, IT WILL HAVE TO BE FIELD INSTALLED.
2. REFER TO SMARTPURGE RETROFIT INSTRUCTIONS FOR DETAILS.

YORK INTERNATIONAL CORPORATION YORK, PA. 17405			
DIMENSIONS ARE IN INCHES DO NOT SCALE		DWG-PURGE VALVE PURGE TANK 16G-21G	
NAME DR. B. W. NADEAU	DATE 03-18-97	SIZE C	SMARTPURGE RETROFIT
APPR. SCALE (N.T.S.)		DRAWING NUMBER M1	
SHEET			

6-030 1/8

PURGE DUCT

DETAIL A

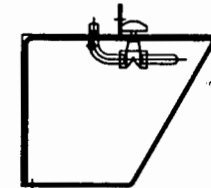
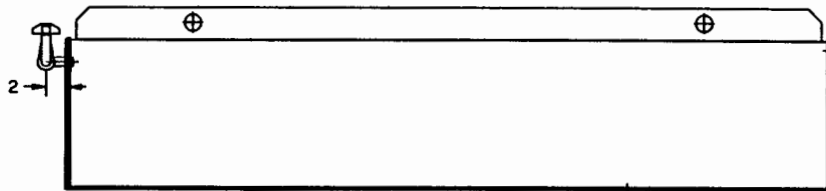
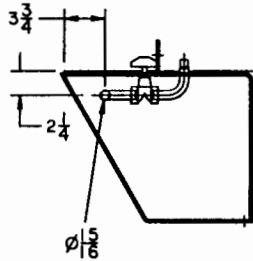

NOTES:

1. IF VALVE ASSEMBLY IS NOT INSTALLED AS SHOWN, IT WILL HAVE TO BE FIELD INSTALLED.
2. REFER TO SMART PURGE RETROFIT INSTRUCTIONS FOR DETAILS.

3. REMOVE ALL OIL, GREASE AND DIRT FROM ITEMS A AND B.
4. PIPE ASSEMBLY IS SIZED FOR SAUNDERS VALVES (ITEM C). IF ITT VALVES ARE USED, TRIM PIECE PARTS TO DIMENSIONS SHOWN.

DETAIL A

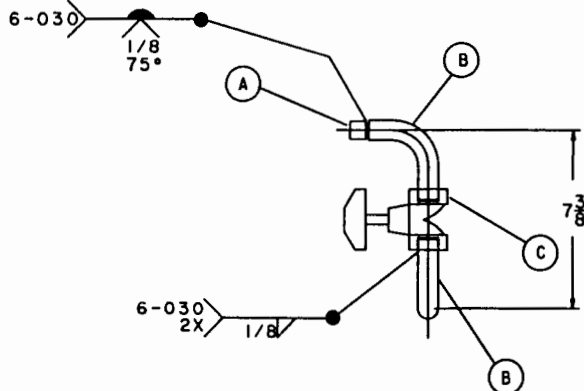
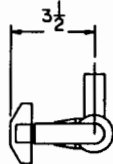

FIELD SUPPLIED COMPONENTS:

- A - 075-14528-000 - COUPLING 1/4" FPT - BUTT WELD
- B - 075-14526-000 - 1/2" LONG RADIUS EL. (QNTY. 2)
- C - 022-08869-052 - 1/2" DIAPHRAGM VALVE - SOCKET WELD.

YORK INTERNATIONAL CORPORATION
YORK, PA. 17405

DIMENSIONS ARE IN INCHES
DO NOT SCALE

DWG-PURGE VALVE
PURGE TANK
22G-22GL

NAME DR. R. W. NARDEAU
DATE 03-18-97
APPR. _____
SCALE N.T.S.

SIZE C

SMARTPURGE
RETROFIT

DRAWING NUMBER

M2

SHEET

NOTES:

1. ALL OIL, GREASE, AND DIRT MUST BE REMOVED FROM ALL COMPONENTS BEFORE INSTALLATION.
2. ALL THREADED CONNECTIONS MUST BE MADE USING ITEMS 013-02899-000, 013-01753-000 AND 013-02280-000.
3. ITEM 2 MUST BE INSTALLED WITH ITS ARROW POINTING TOWARDS THE FLANGE.

UNIT	DIM. A	DIM. B	DIM. C
12SC,13S,13SC,14S 15SL,16S,16SL,17S 18S,19S,19GL,20G,21G	7-1/4"	5-1/2"	25-3/4"
14SC,15S,22G,22GL	10-7/8"	9-1/16"	33"

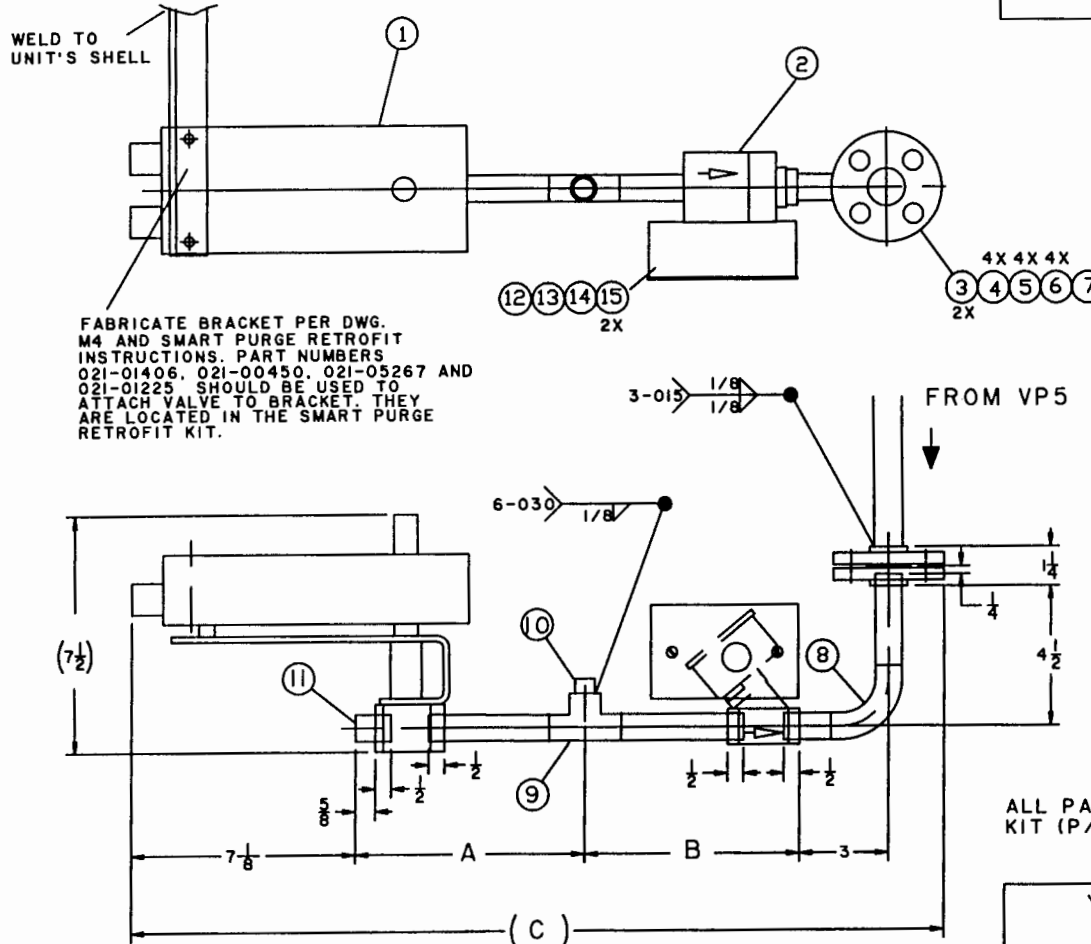

PARTS LIST:

- 022-09562-000 - MOTORIZED BALL VALVE.
- 022-09563-000 - SOLENOID VALVE.
- 023-10770-000 - 1/2" FLANGE (QNTY. 2)
- 021-02794-000 - SCREW CAP HEX - 5/8"-11UNC (QNTY. 4).
- 021-00495-000 - NUT HEX - 5/8" - 5/8"-11UNC (QNTY. 4).
- 021-05273-000 - 5/8" LOCK WASHER (QNTY. 4)
- 075-23414-000 - NEOPRENE GASKET 1-7/8" OD.
- 075-14526-000 - 1/2" LONG RADIUS ELBOW.- BUTT WELD.
- 023-10743-000 - 1/2" TEE BUTT WELD.
- 075-14528-000 - 1/4" FPT COUPLING - BUTT WELD.
- 023-14617-000 - 1/2" NPT THREADED NIPPLE
- 025-01146-000 - 2x4 ELECTRICAL WORK BOX.
- 025-01732-000 - 2X4 BOX COVER
- 025-05806-000 - CHASE NIPPLE
- 025-05701-000 - LOCK NUTS (QNTY. 2)

ALL PARTS LISTED ABOVE ARE IN SMART PURGE RETROFIT KIT (P/N 325-32967-000).

YORK INTERNATIONAL CORPORATION
YORK, PA. 17406

DIMENSIONS ARE IN INCHES
DO NOT SCALE

DWG-MECHANICAL
SMART PURGE VALVES/PIPING

NAME: DR. R. W. NADEAU
DATE: 03-18-97
APPR: _____
SCALE: N.T.S.

SIZE: C
SMARTPURGE
RETROFIT

DRAWING NUMBER
M3

SHEET

NOTES:

1. BRACKET MUST BE CUT TO LENGTH. IF NO ANGLE IS NEEDED, DIMENSION A = B.
2. BRACKET MATERIAL IS NOT SUPPLIED WITH KIT.
3. BRACKET SHOULD BE WELDED TO MAIN SHELL AS DETAILED IN SMART PURGE RETROFIT INSTRUCTIONS.
4. THE UNIT MUST BE IN A SLIGHT POSITIVE PRESSURE (NITROGEN OR ARGON) BEFORE WELDING BRACKET TO THE SHELL.

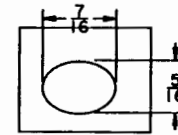

DETAIL A
2X

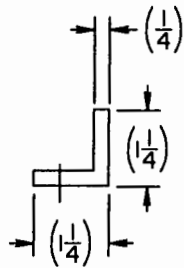
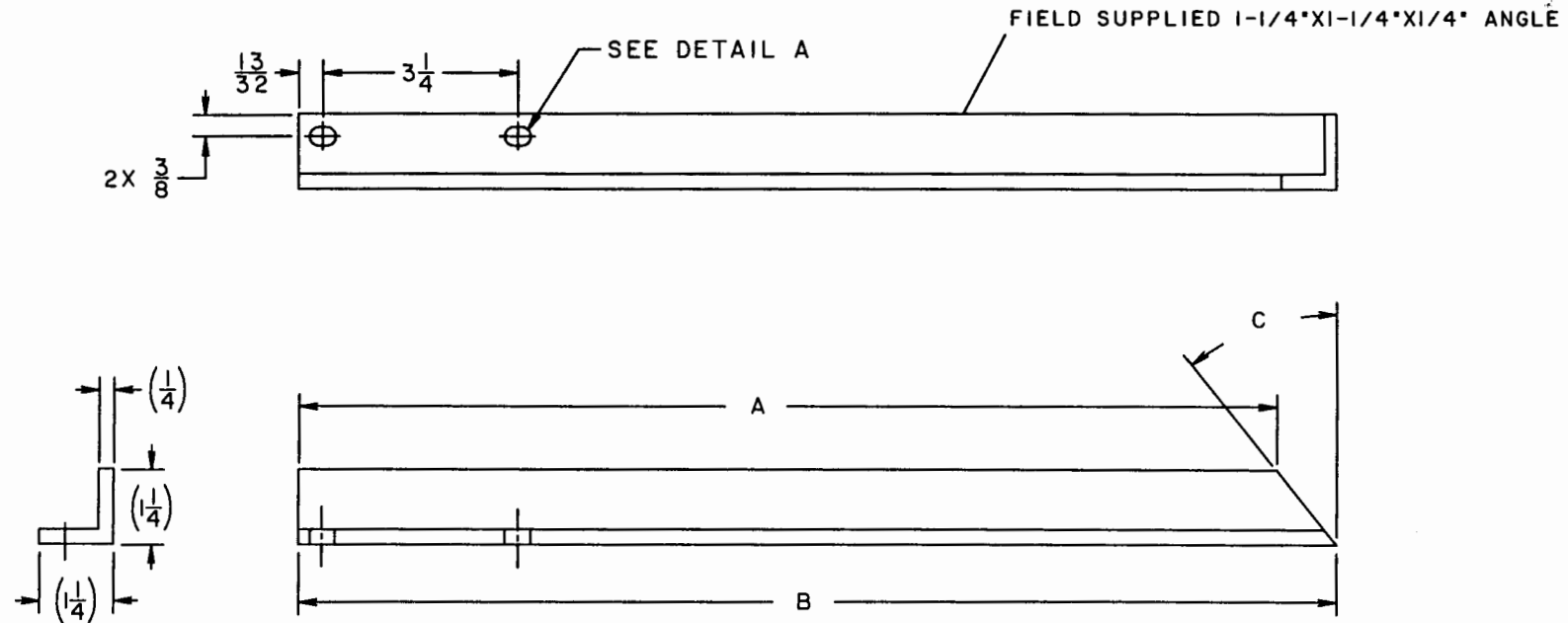

YORK INTERNATIONAL CORPORATION YORK, PA. 17406			
DIMENSIONS ARE IN INCHES DO NOT SCALE		DWG-MECHANICAL BRACKET	
NAME DR. R.W. NADEAU APPR. _____ SCALE: N.T.S.	DATE 03-19-97	SIZE C	SMARTPURGE RETROFIT
DRAWING NUMBER M4			SHEET

MODEL S UNITS

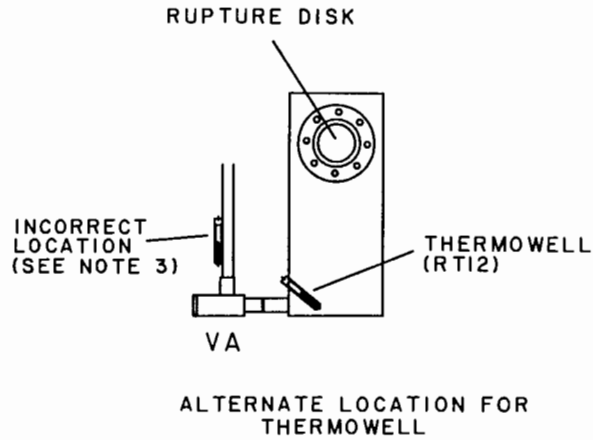
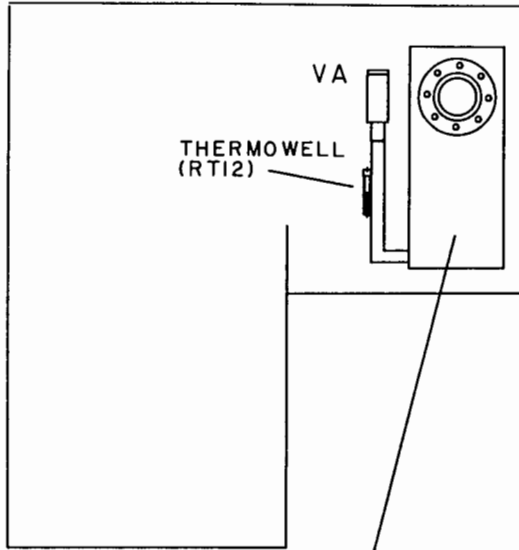

MODEL G UNITS

LOW TEMP. GENERATOR
CONDENSATE LEAVING SIDE

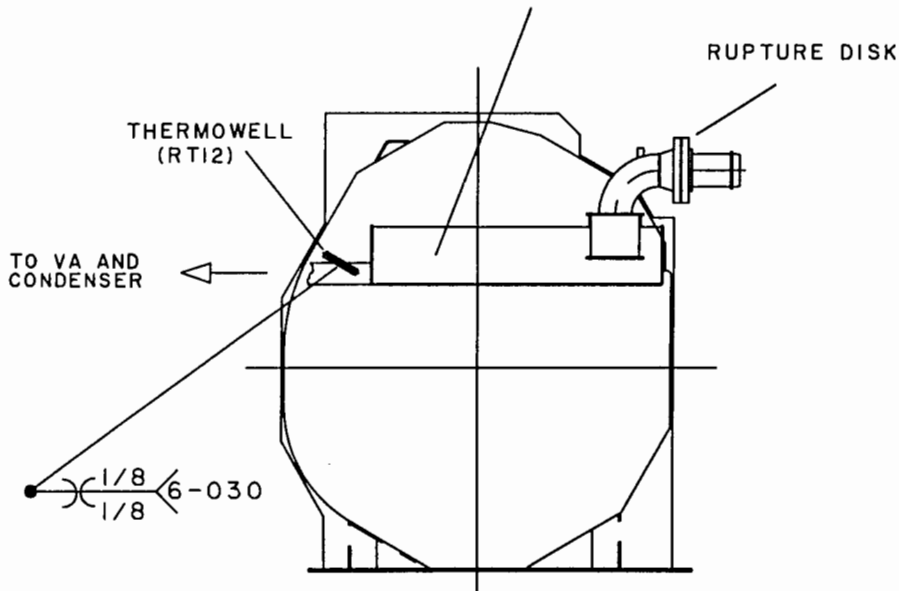

NOTES:

1. REFER TO DWG M6 FOR THERMOWELL DETAIL.
2. INSTALL THERMOWELL ON PIPE AS SHOWN. IF INSUFFICIENT ROOM IS AVAILABLE BETWEEN THE LOW TEMP. GEN. CONDENSATE BOX AND VA, THE THERMOWELL SHOULD BE INSTALLED IN THE ALTERNATE LOCATION SHOWN ABOVE.
3. DO NOT INSTALL OR USE A THERMOWELL THAT IS DOWN STREAM OF VA.

YORK INTERNATIONAL CORPORATION
YORK PA. 17405

DIMENSIONS ARE IN INCHES
DO NOT SCALE

DWG-MECHANICAL
THERMOWELL LOCATIONS

NAME DATE
DR. B. W. NADEAU 03-18-97
APPR. _____
SCALE: N.T.S.

SIZE
C

SMARTPURGE
RETROFIT

DRAWING NUMBER

M5

SHEET

4

3

2

1

D

D

C

C

B

B

A

A

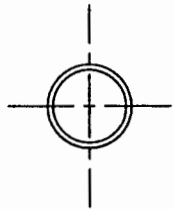

6-030
1/8"

DISK - 3/8"
DIAMETER

FIELD SUPPLIED 3/8" SCH40 BLK PIPE.
CUT TO LENGTH.

5.0'

NOTES:

1. BOTH ITEMS ARE FIELD SUPPLIED.
2. WELD THERMOWELL TO UNIT IN LOCATION SPECIFIED IN RETROFIT INSTRUCTIONS AND DWG M5.

YORK INTERNATIONAL CORPORATION YORK, PA. 17405			
DIMENSIONS ARE IN INCHES DO NOT SCALE		DWG-MECHANICAL THERMOWELL (RT12)	
NAME DR. R. W. MADEAU	DATE 03-18-97	SIZE C	SMARTPURGE RETROFIT
APPR. SCALE N.T.S.		DRAWING NUMBER M6	
SHEET			

4

3

2

1

DETAIL A

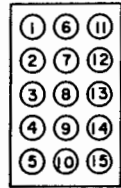

P17 (025-28385-000)

TOP VIEW

CONNECTIONS

PURGE PUMP TRANSDUCER PT3

- ① BLACK
- ⑥ RED
- ⑪ WHITE/GREEN

PURGE TANK TRANSDUCER PT4

- ③ BLACK
- ⑧ RED
- ⑬ WHITE/GREEN

DETAIL B

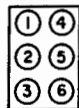

P8 (025-28382-000)

TOP VIEW

CONNECTIONS

LEAVING REFRIG TEMP THERMISTOR RT12

- ⑤ BLACK
- ④ RED

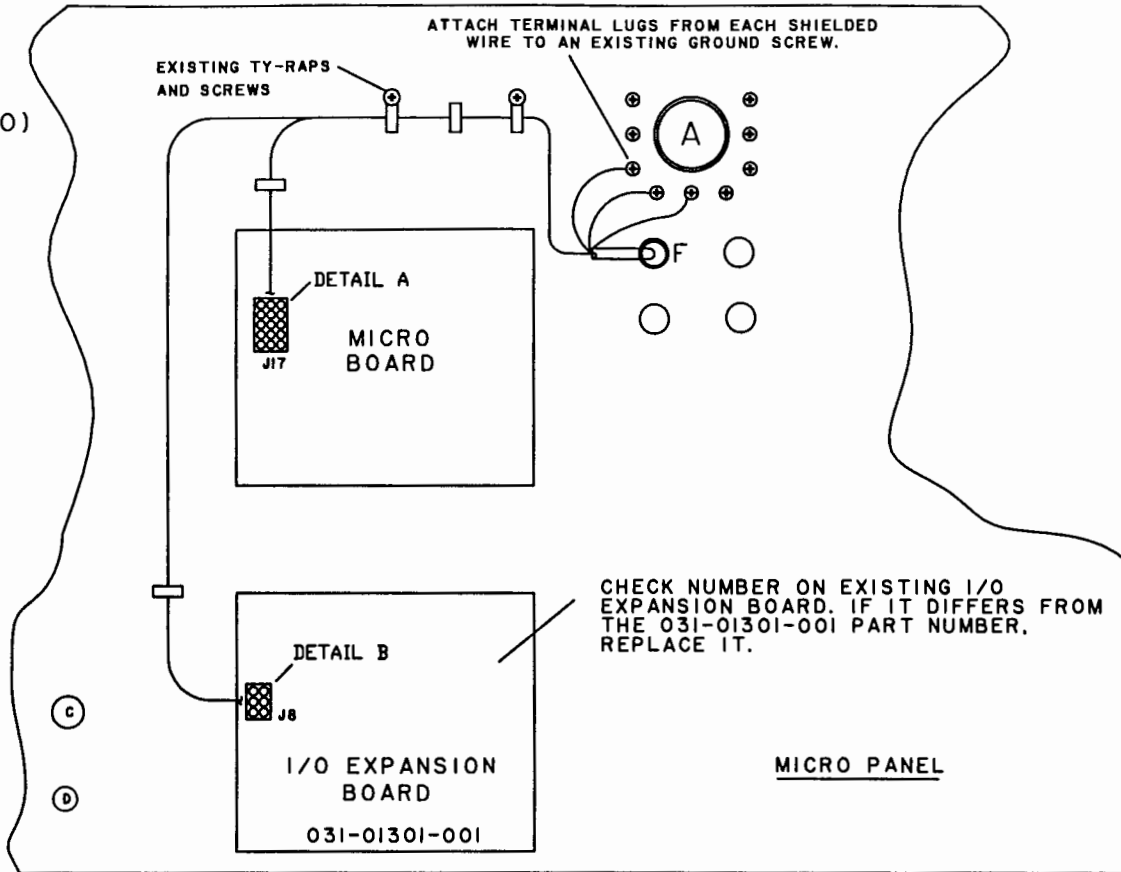

CHECK NUMBER ON EXISTING I/O EXPANSION BOARD. IF IT DIFFERS FROM THE 031-01301-001 PART NUMBER, REPLACE IT.

NOTES:

1. 2 - THREE WIRE AND 1 - TWO WIRE SHIELDED CABLES WILL HAVE TO BE RUN. LENGTHS TO BE DETERMINED IN FIELD. CABLE PART NUMBERS ARE 025-28701-003 AND 025-28701-002 RESPECTIVELY.

2. SOCKET CONTACTS (025-28386-000) SHOULD BE CRIMPED ON TO WIRE USING AMP (P/N 755331-1) AND INSTALLED INTO APPROPRIATE RECEPTACLES IN P8 AND P17 AS SHOWN IN DETAILS A AND B.

YORK INTERNATIONAL CORPORATION YORK, PA. 17406			
DIMENSIONS ARE IN INCHES DO NOT SCALE		DWG-WIRING MICROBOARD CONN. ALL UNITS	
NAME DR. R.W. MADEAU APPR. _____ SCALE N.T.S.	DATE 03-18-97	SIZE C	SMARTPURGE RETROFIT
			DRAWING NUMBER W1
SHEET			

4 3 2 1

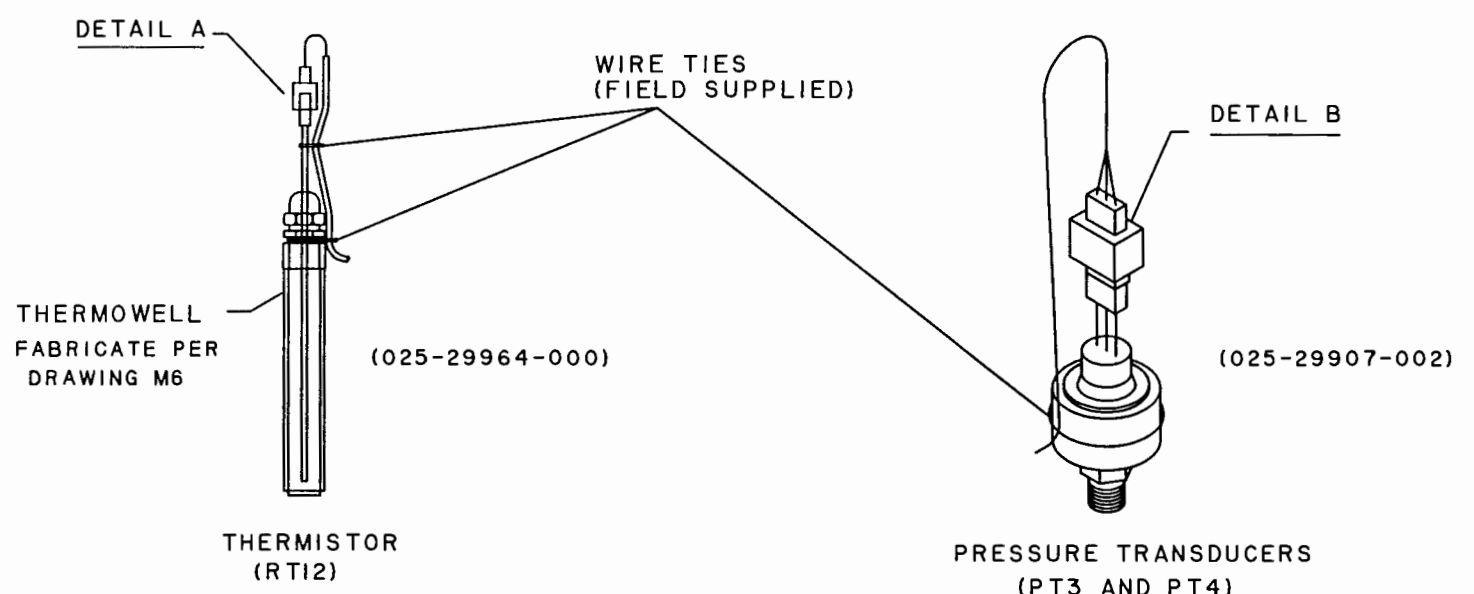

DETAIL A

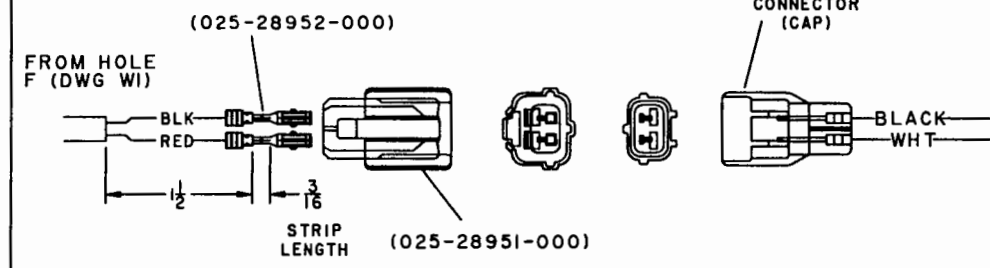

DETAIL B

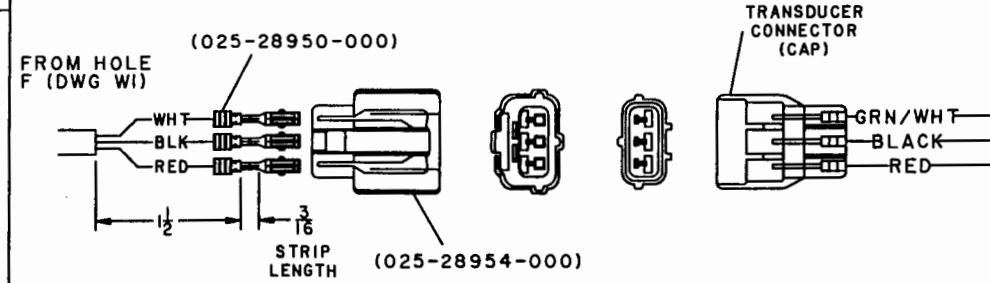

NOTES:

1. THERMOWELL SHOULD BE FABRICATED USING DRAWING NUMBER M6. PARTS TO BE PURCHASED LOCALLY. A PLASTIC NUT MAY BE SUPPLIED WITH THE THERMISTOR AS SHOWN IN THE DRAWING. IT DOES NOT NEED TO BE USED.
2. FILL THERMOWELL WITH A THERMAL HEAT TRANSFER COMPOUND BEFORE INSTALLING THERMISTOR. OUTSIDE OF WELL SHOULD BE INSULATED USING FIBERGLASS INSULATION.
3. PART NUMBER (025-28952) SHOULD BE CRIMPED ON TO THE SHIELDED CABLE USING USING AMP P/N 755262-1.

YORK INTERNATIONAL CORPORATION YORK, PA. 17405			
DIMENSIONS ARE IN INCHES DO NOT SCALE		DWG-WIRING THERMISTOR/TRANSDUCER CONNECTIONS	
NAME DR. R.W. NADEAU APPR. _____ SCALE: N.T.S.	DATE 03-18-97	SIZE C	SMARTPURGE RETROFIT
DRAWING NUMBER W2			SHEET

4 3 2 1

NOTES:

1. CONNECT USING 3/8" 14-3 CONDUCTOR (FIELD SUPPLIED) BX CABLE OR GREENFIELD. LENGTH TO BE DETERMINED IN FIELD.

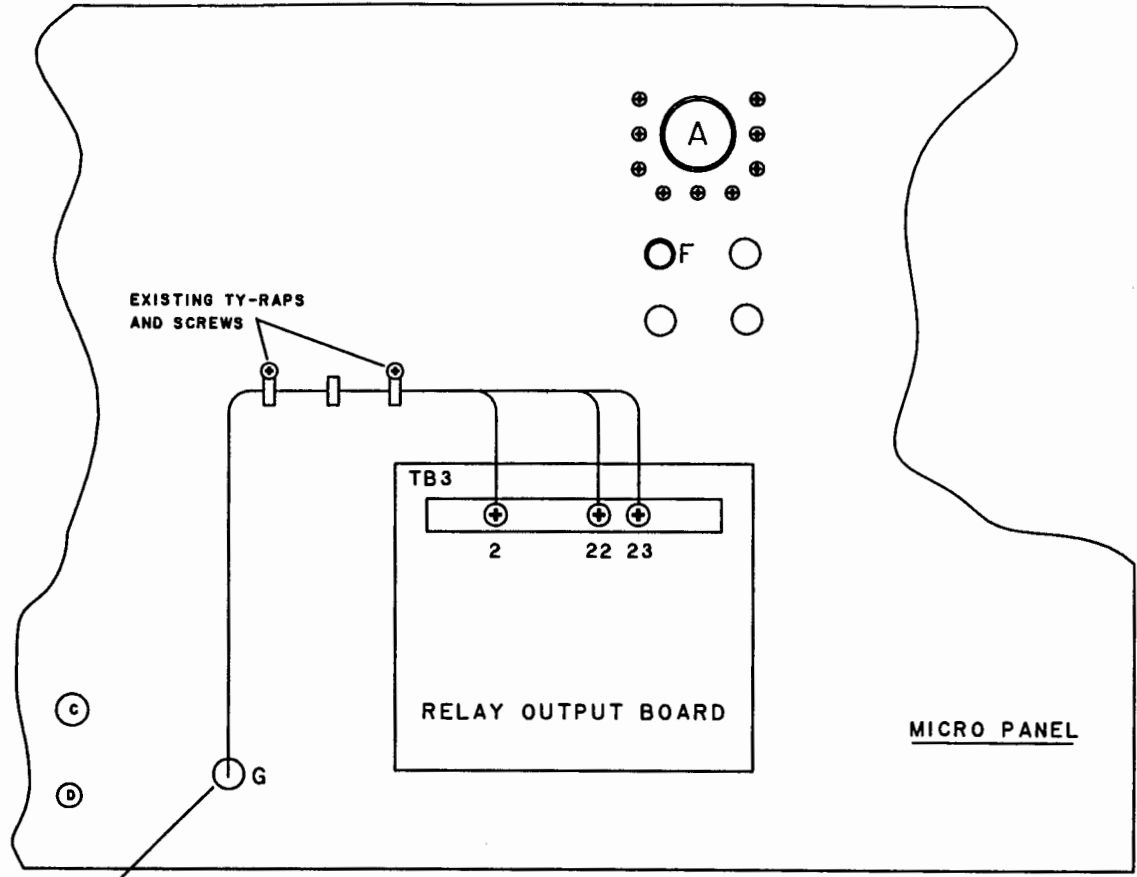

CHOOSE ANY CONVENIENT KNOCKOUT.

CONNECTIONS:

- TB3-2 115VAC NEUTRAL (GND.)
- TB3-22 115VAC (TO PURGE TANK SOLENOID)
- TB3-23 115VAC (TO PURGE PUMP SOLENOID)

YORK INTERNATIONAL CORPORATION YORKPA.17405			
DIMENSIONS ARE IN INCHES DO NOT SCALE		DWG-WIRING MICROBOARD CONN. PURGE VALVES	
NAME DR. B.W. MADEAU APPR. _____ SCALE 1/4" = 1"	DATE 03-18-97	SIZE C	SMARTPURGE RETROFIT
			DRAWING NUMBER W3
			SHEET

3/8" STRAIGHT CONN.
(025-06678-000)

WIRES 2, 22, AND 23 FROM
RELAY OUTPUT BOARD IN
MICRO-PANEL
REFER TO DWG. W3.

FIELD SUPPLIED 3/8" 14-3
BX CABLE OR GREENFIELD. LENGTH TO BE
DETERMINED IN FIELD.

USE EXISTING UNISTRUT TO SUPPORT CABLE.
UNISTRUT CLAMPS ARE TO BE FIELD SUPPLIED.

JUNCTION BOX INSTALLED IN FIELD
ON SIDE OF PURGE TANK SOLENOID
VALVE COIL (ISOL). REFER TO DWG. M3
FOR MOUNTING LOCATION.

3/8" 90 DEG. CONN.
(025-08199-000)

FIELD SUPPLIED 3/8"
GREENFIELD.
RUN EXISTING WIRES FROM
2SOL THROUGH GREENFIELD.

1/2" CHASE NIPPLE
(025-05806-000)
LOCKNUT (QNTY. 2)
(025-05701-000)

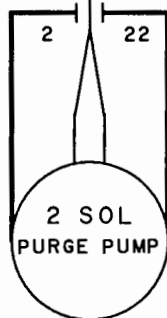

MOTORIZED BALL VALVE
(022-09562-000)

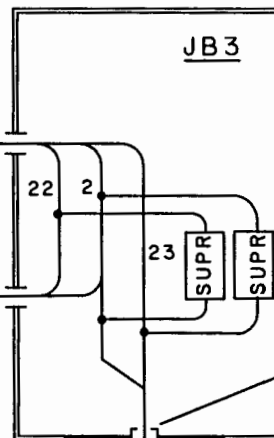

SOLENOID VALVE
(022-09563-000)

NOTES:

1. SURGE SUPPRESSORS (031-00808-000) MUST
BE INSTALLED AT VALVE LOCATION.

CONNECTIONS:

- WIRE #2 - FROM TB3-2 115VAC NEUTRAL (GND.)
- WIRE #22 - FROM TB3-22 115VAC (TO PURGE TANK SOLENOID)
- WIRE #23 - FROM TB3-23 115VAC (TO PURGE PUMP SOLENOID)

YORK INTERNATIONAL CORPORATION YORK, PA. 17405			
DIMENSIONS ARE IN INCHES DO NOT SCALE		DWG-WIRING PURGE VALVE CONNECTIONS	
NAME DR. R. W. NADEAU	DATE 09-31-97	SIZE C	SMARTPURGE RETROFIT
DRAWING NUMBER W4			SHEET

