

BUFFALO CAN-O-MATIC[®]

The Reliable Zero Leakage Pumps



CAN-O-MATIC® THE RELIABLE ZERO LEAKAGE PUMPS

BACKGROUND

Reliability . . . next to leakproof design it's undoubtedly the single most important feature in a hermetically sealed pump. That's why Buffalo Can-O-Matic® Pumps are designed to deliver maximum service life with minimum maintenance.

Realizing that the motor bearings were the weak point in a hermetically sealed pump, Buffalo engineers selected a patented, spring-loaded, self-adjusting, self-lubricating tapered carbon graphite bearing for the Can-O-Matic motor. In operation, bearing wear is evenly distributed and automatically compensated. Concentric rotation of the rotor-impeller assembly is maintained, regardless of natural bearing wear. This effectively prevents mechanical contact between the rotor can and stator can. This superior bearing design is incorporated into a motor-pump assembly which features balanced axial and radial thrust . . . back pull-out construction, standard dimensions, and interchangeability of many pump end components with other Buffalo pump types.

Extensive field experience with thousands of Can-O-Matics now in service has proven the correctness of the Can-O-Matic design. If you want a trouble-free leakproof pump, this is the one to select.

APPLICATIONS

Can-O-Matic® Pumps are being used where the possibility of leakage is unacceptable. Typically, these conditions involve health, safety or financial considerations, and on installations where the pump will not be readily accessible for routine inspection and maintenance. Can-O-Matics are handling refrigerants, high temperature water, toxic, volatile, carcinogenic and corrosive liquids.

ENGINEERING ASSISTANCE

The Buffalo Sales Engineer in your area is in a unique position to help you apply Can-O-Matic® Pumps to situations requiring leakproof performance. The wealth of information at his disposal includes specification, installation and performance on both in-plant and OEM applications. The

sooner you call him, the sooner you can end serious pump leakage problems.

CAN-O-MATIC OVERALL SPECIFICATIONS GENERAL DESCRIPTION

The Can-O-Matic is a close coupled, enclosed impeller, end suction pump which has the motor stator and rotor hermetically sealed in separate "cans". The motor assembly is sealed to the pump casing. No stuffing box is required. Special tapered carbon graphite bearings are spring loaded to maintain concentric rotation of the rotor can. This eliminates mechanical contact between the rotor and stator cans.

MODELS AVAILABLE

- HCR - A GENERAL PURPOSE
LEAKPROOF PUMP
- HFF & HFFA - LEAKPROOF PUMPS FOR
HIGH HEAD PERFORMANCE
- HCCO - A LEAKPROOF PUMP FOR
HANDLING REFRIGERANTS
- HCCLY - LEAKPROOF PUMP FOR HIGH
WORKING PRESSURES
- HLYD - A LEAKPROOF PUMP FOR LARGE
CAPACITIES, STANDARD AND HIGH
WORKING PRESSURES

SPECIFICATIONS

- CAPACITIES TO 1200 gpm
- WORKING PRESSURE TO 600 psi
- TEMPERATURE RANGE -120° F to +490° F
- HEADS TO 480'

MATERIALS OF CONSTRUCTION

- Ductile Iron - Cast Iron Fitted
- Ductile Iron - Bronze Fitted
- Ductile Iron - 316SS Fitted
- All 316SS
- Nickel
- Monel
- Any combination of the above

CAN-O-MATIC® THE RELIABLE ZERO LEAKAGE PUMPS

CAN-O-MATIC® CAPABILITIES

Containing troublesome liquids

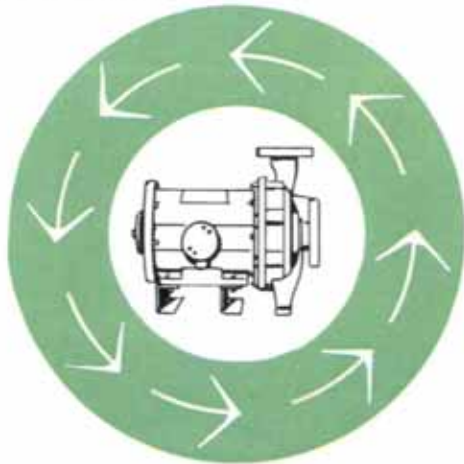

Can-O-Matic Pumps are hermetically sealed units. They allow you to safely handle hot, cold, toxic, corrosive and generally troublesome liquids without the fear of leakage.

Coping with temperature extremes

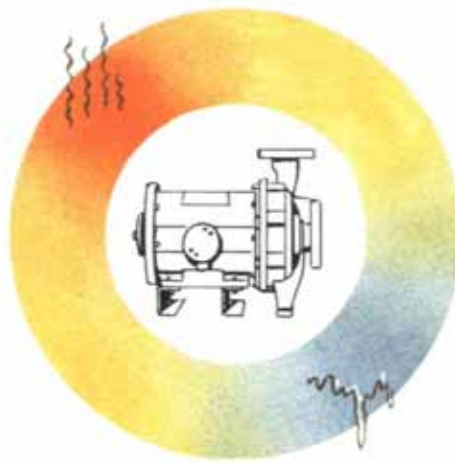

Liquids from -120°F to $+490^{\circ}\text{F}$ are successfully handled with Can-O-Matic Pumps. Ambient air, either naturally or fan circulated, provides motor temperature control.

Contamination free liquid handling



Being a hermetically sealed heliarc welded assembly, without stuffing box or mechanical seal, outside contaminants cannot enter a system through a Can-O-Matic Pump.

Extended service life



To provide continuous maintenance-free service over an extended period, Buffalo Can-O-Matics have tapered spring-loaded self-adjusting carbon graphite bearings.

CAN-O-MATIC[®] THE RELIABLE ZERO LEAKAGE PUMPS



HCR



HCCO



HCR - FAN COOLED



HCCLY



HFF



HLYD

CAN-O-MATIC® THE RELIABLE ZERO LEAKAGE PUMPS

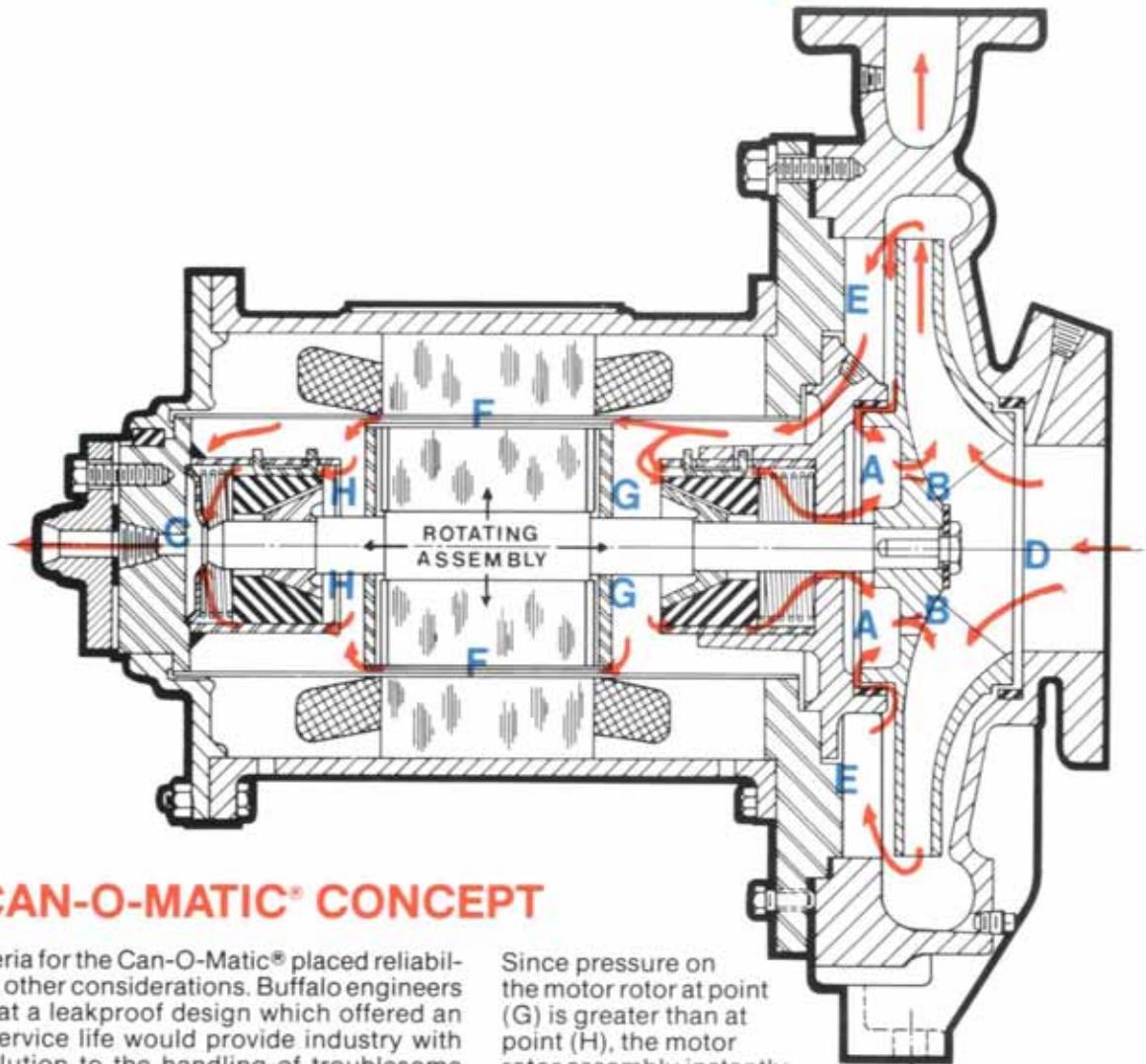

THE CAN-O-MATIC® CONCEPT

Design criteria for the Can-O-Matic® placed reliability above all other considerations. Buffalo engineers believed that a leakproof design which offered an extended service life would provide industry with the true solution to the handling of troublesome liquids. Experience with Can-O-Matics on a variety of applications has proven the correctness of this approach.

In the Can-O-Matic Pump, two opposing axial forces are balanced to create a state of equilibrium between the rotating and stationary elements. This condition is attained by the action of the pumped liquid as it passes through the impeller balance chamber (A), impeller balance holes (B), and the patented Thrust-O-Matic® device (C), consisting of a throttle plate with orifice and specially tapered shaft on the motor end farthest from the impeller. Internal stresses at the bearings are reduced to the absolute minimum. In operation, this works as follows: when the pump is started, the rotating assembly (impeller & motor rotor) moves toward the pump suction (D). This is caused by the discharge pressure acting on the back shroud (E) of the impeller.

At this point, the Thrust-O-Matic orifice (C) is at its maximum opening.

The resultant flow of liquid through the small annular space (F) between the rotor can and stator can creates a pressure drop across the motor rotor.

Since pressure on the motor rotor at point (G) is greater than at point (H), the motor rotor assembly instantly moves toward the Thrust-O-Matic orifice (C). The taper at the end of the motor shaft enters in the Thrust-O-Matic orifice reducing its opening.

This reduces the potential for flow of pumped liquid across the motor rotor, reducing pressure drop across the rotor, tending then to move the rotating assembly toward the suction end (D). The process repeats with increasingly smaller pressure differentials and rotating assembly movement, until equilibrium of the rotating assembly is attained.

The balancing holes in the impeller (B) serve as an orifice between pump discharge pressure at (E) and pump suction at (D). The balancing holes (B) and balancing chamber (A) control the axial thrust created by the impeller. This aids in the balancing of the rotating assembly.

Flow passages around the impeller, the size of the balance chamber, balance holes through the impeller, groove size in the bearings, and orifice opening and shaft taper have all been designed to provide maximum reliability for extended maintenance-free service.

DESIGN FEATURES FOR EXTENDED SERVICE LIFE

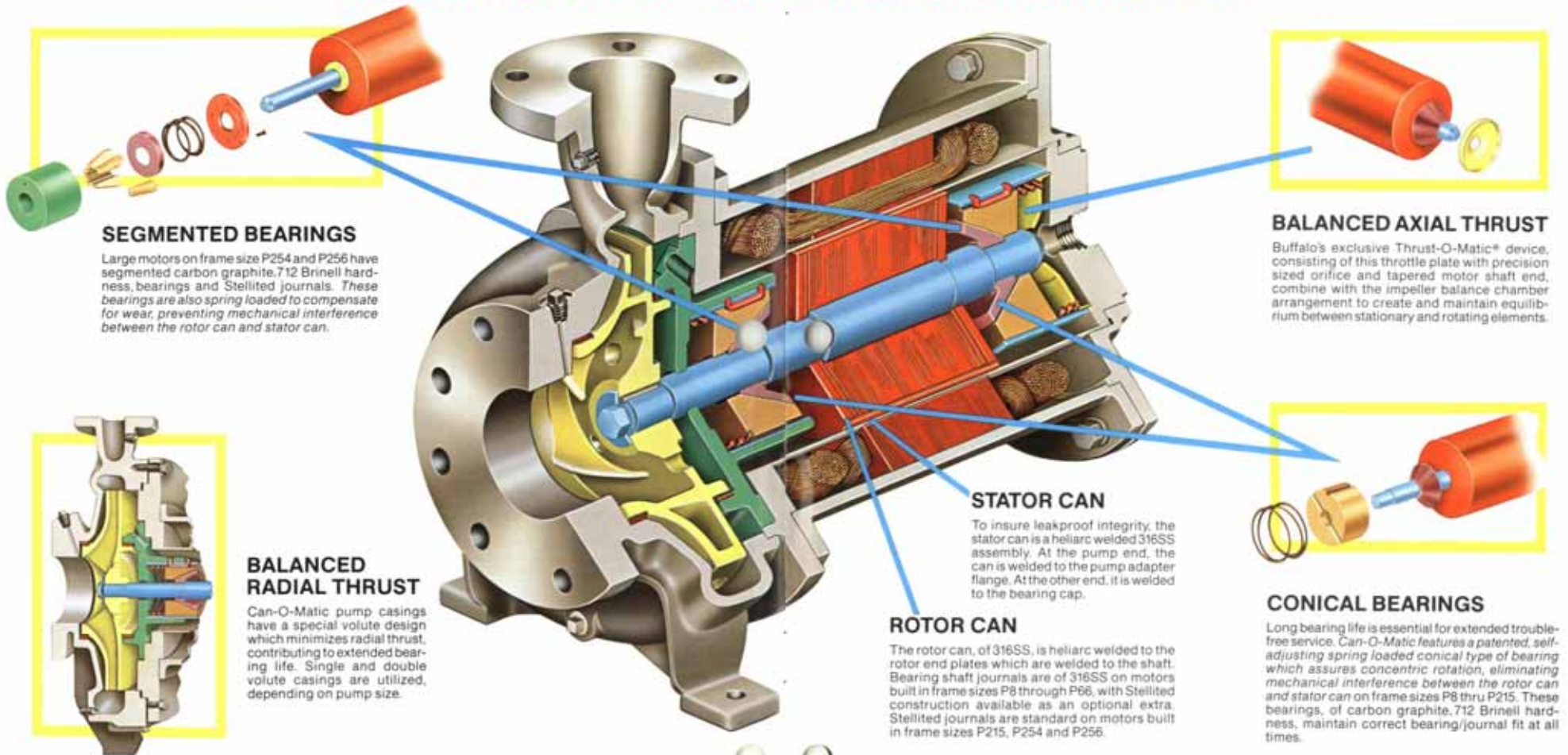

SEGMENTED BEARINGS

Large motors on frame size P254 and P256 have segmented carbon graphite, 712 Brinell hardness, bearings and Stellite journals. These bearings are also spring loaded to compensate for wear, preventing mechanical interference between the rotor can and stator can.

BALANCED RADIAL THRUST

Can-O-Matic pump casings have a special volute design which minimizes radial thrust, contributing to extended bearing life. Single and double volute casings are utilized, depending on pump size.

STATOR CAN

To insure leakproof integrity, the stator can is a heliarc welded 316SS assembly. At the pump end, the can is welded to the pump adapter flange. At the other end, it is welded to the bearing cap.

ROTOR CAN

The rotor can, of 316SS, is heliarc welded to the rotor end plates which are welded to the shaft. Bearing shaft journals are of 316SS on motors built in frame sizes P8 through P66, with Stellite construction available as an optional extra. Stellite journals are standard on motors built in frame sizes P215, P254 and P256.

BALANCED AXIAL THRUST

Buffalo's exclusive Thrust-O-Matic® device, consisting of this throttle plate with precision sized orifice and tapered motor shaft end, combine with the impeller balance chamber arrangement to create and maintain equilibrium between stationary and rotating elements.

CONICAL BEARINGS

Long bearing life is essential for extended trouble-free service. Can-O-Matic features a patented, self-adjusting spring loaded conical type of bearing which assures concentric rotation, eliminating mechanical interference between the rotor can and stator can on frame sizes P8 thru P215. These bearings, of carbon graphite, 712 Brinell hardness, maintain correct bearing/journal fit at all times.

MOTOR TEMPERATURE CONTROL

Can-O-Matic pumps utilize ambient air to control motor operating temperatures, either natural or forced circulation, with a fan, depending on liquid temperature, motor frame rating and insulation. For the natural circulation design, heat is transferred from the outside surface of the motor housing to ambient air. The forced circulation design features a fan at the motor end of the pump and a special perforated end plate. Air is blown through the holes in the end plate, across the stator windings, exiting through a screened opening in the motor housing near the pump end. In all cases, the pumped liquid flowing through the motor maintains bearing temperatures at their self-lubricating level. Complete horsepower/temperature data is on page 17.

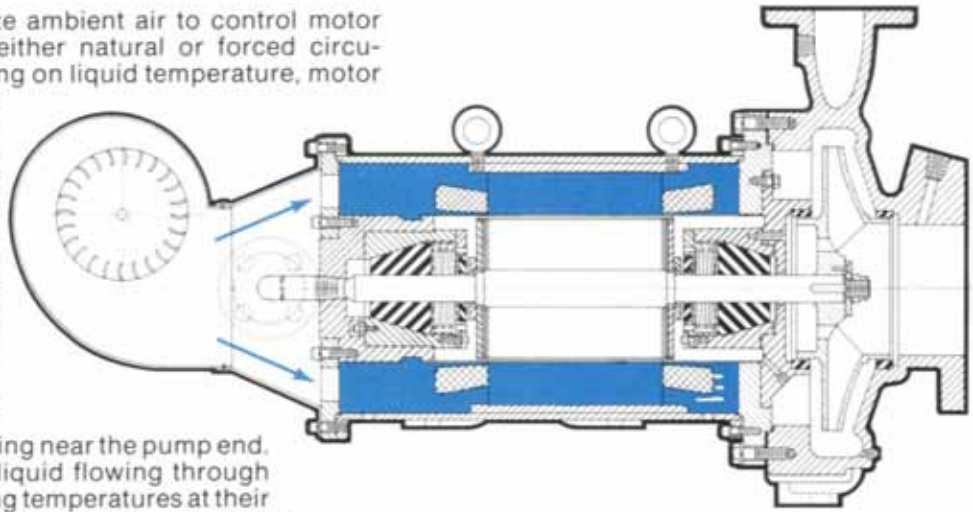

INSULATION

Two classes of stator insulation are furnished on Can-O-Matic pumps. Class "H" insulation, with silicone rubber covering, is used for liquid temperatures from -120°F up to $+370^{\circ}\text{F}$. Class "C" insulation, with silicone rubber covering, is used for liquid temperatures from -120°F up to $+455^{\circ}\text{F}$ and on fan cooled units up to $+490^{\circ}\text{F}$. Stator windings are varnished and silicone rubber covered to offer maximum protection against condensation inside the motor housing. Since the Can-O-Matic is a back withdrawal design, a replacement motor can be installed without disturbing piping. Complete insulation data is on page 17.

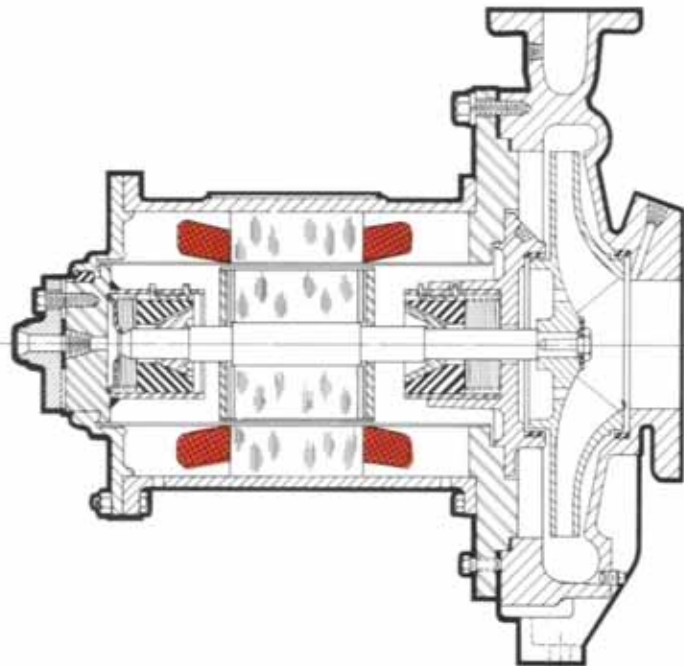

Recirculation Systems

A pumped liquid recirculation system is an integral component of each Can-O-Matic installation. The liquid which flows through the Can-O-Matic, to bring the rotor-impeller assembly into balance and control bearing temperature, returns to the system via the recirculation piping. Two different recirculation piping arrangements are used depending on the nature and temperature of the pumped liquid.

NON-SATURATED LIQUIDS are handled with a recirculation system which is installed from the Can-O-Matic motor end to the suction piping.

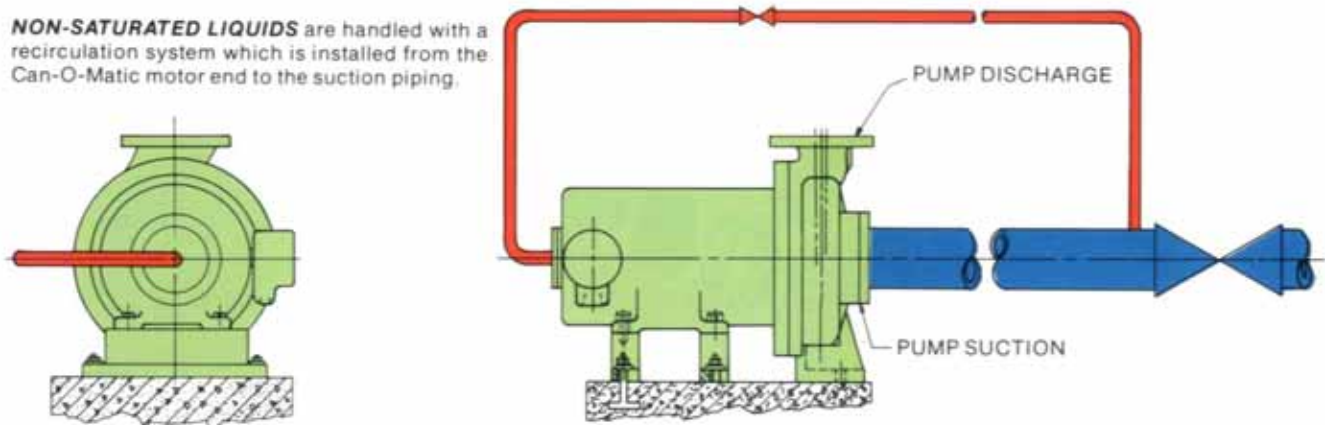

SATURATED LIQUIDS require a recirculation line from the pump motor end to the supply tank above maximum liquid level. This is done to allow the recirculation liquid to flash in the supply tank rather than at the pump inlet which would cause cavitation.

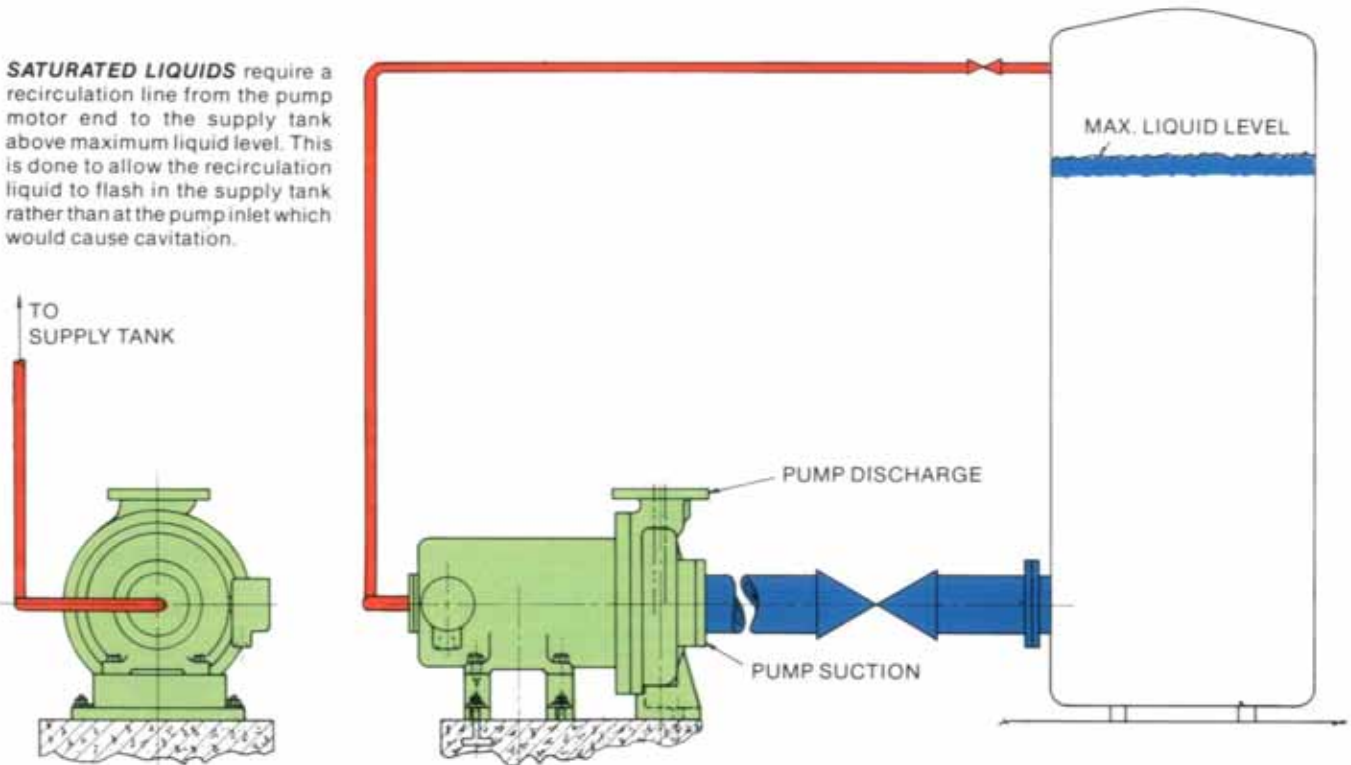

CAN-O-MATIC® THE RELIABLE ZERO LEAKAGE PUMPS

MAJOR COMPONENTS

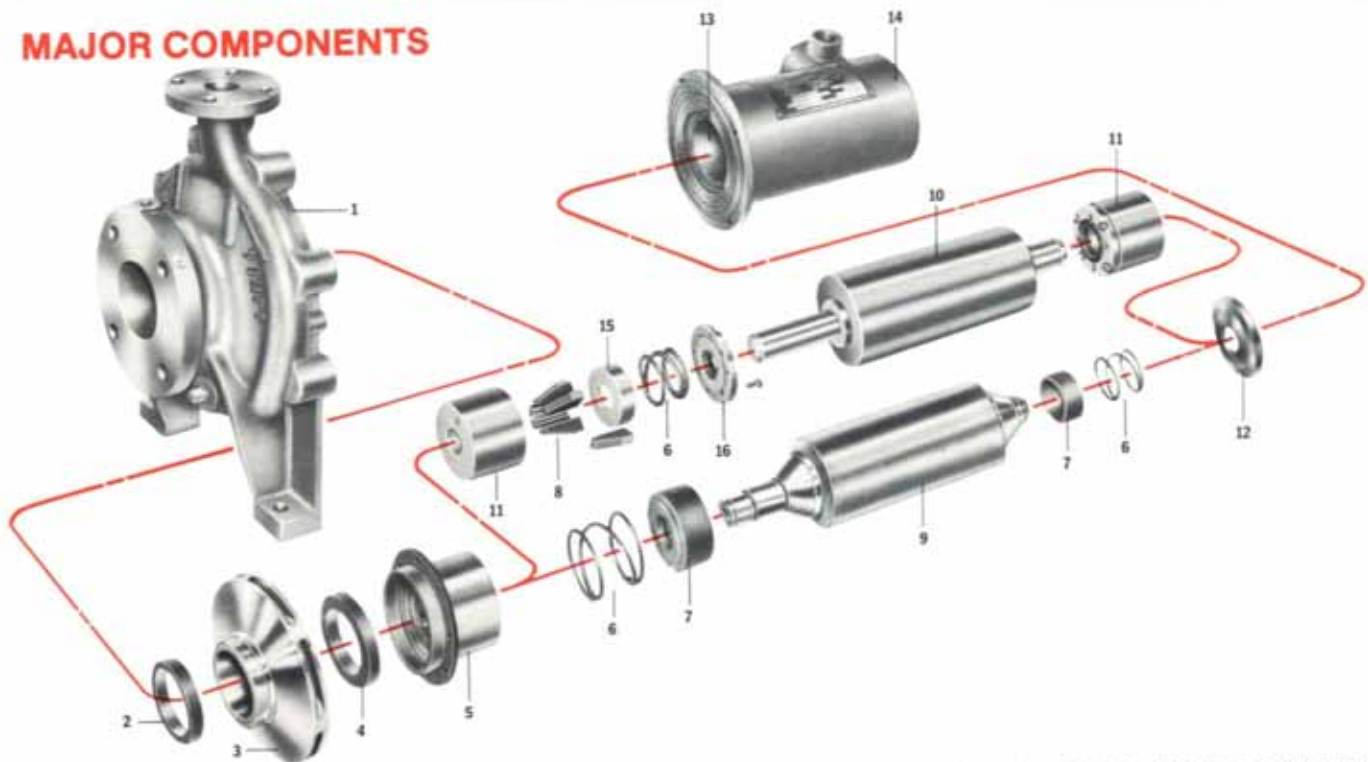

- 1 Casing** is a back pull out design, top discharge, self-venting. Material of construction suitable for liquid being pumped.
- 2 Casing wear rings** of carbon graphite are compatible with most liquids. They can be readily replaced.
- 3 Impeller** is single suction enclosed type, hydraulically balanced to minimize axial and radial thrust. Material of construction suitable for liquid pumped.
- 4 Motor wear ring** of carbon graphite. Compatible with most liquids, they can be easily replaced.
- 5 Front motor housing** contains motor wear ring and pump end bearing assembly which keeps rotor and impeller in alignment.
- 6 Bearing springs** of 316 stainless steel automatically compensate for bearing wear assuring correct bearing/journal fit at all times.
- 7 Conical bearings** of carbon graphite construction are tapered internally to fit rotor journals and compensate for wear. Concentric rotation is assured, eliminating mechanical interference between rotor can and stator can.
- 8 Segmented bearings** of carbon graphite construction are used on motors built in frames P245 and P256. They are tapered externally to fit the bearing housing and spring loaded to compensate for wear. Concentric rotation is assured. Mechanical contact between rotor can and stator can is prevented.
- 9 Motor rotor**, used with conical bearings on motors built in frame sizes P8, P66 and P215, is hermetically sealed in a 316 stainless steel can. Shaft is also 316 stainless steel. Tapered journals are 316 stainless steel for motors built in frame sizes P8 and P66 and Stellite on size P215.
- 10 Motor rotor**, used with segmented bearings on motors built in frames P245 and P256, is hermetically sealed in a 316 stainless steel can. Straight bearing journals are Stellite.
- 11 Bearing housing** used to contain segmented bearings on motors built on frames P245 and P256.
- 12 Thrust-O-Matic® orifice plate** of 316 stainless steel is a major component in the axial thrust balance system.
- 13 Stator can**, heliarc welded to motor flange, is 316 stainless steel. Standard pressure is 200 psi. Can is reinforced for higher working pressures.
- 14 Motor housing** is a cast iron enclosed type with 1/2" drains for condensation elimination. The cast aluminum conduit box is liquid tight and explosion proof. Leads from the stator to the box are sealed at the housing.
- 15 Spring retainer**
- 16 Bearing cover**

Parts List Referring to Diagrams Page 11

PART NO.	NAME OF PART	PART NO.	NAME OF PART	PART NO.	NAME OF PART
2	CASING	202	MOTOR FLANGE	229	ROTOR SHAFT
3	IMPELLER	205	BEARING HOUSING	238	RETAINING CLIP - BEARING
9	CASING RING	206	BRG. HOUSING INSERT	242	JACK SCREW
10	MOTOR RING	207	FRONT HOOD	243	COLLAR
15A	IMPELLER LOCKING SCREW	208	WEAR RING HOUSING	244	BEARING COVER
16	IMPELLER WASHER	210	BEARING-CONICAL	245	THRUST COLLAR
17B	FEATHER KEY (IMPELLER)	211	CONICAL BEARING JOURNAL	246	SPRING RETAINER
56	MOTOR SUPPORT	212	ROTOR END PLATE	247	BEARING - SEGMENTED
65	GASKET-CASING	216	STATOR CAN	248	BEARING HOUSING
65A	GASKET-SUCTION PIECE	221	ROTOR CAN	250	SPRING
90	COMPRESSION FLANGE	222	STATOR CORE ASSEMBLY	258	THRUST-O-MATIC ORIFICE
201	FIELD SHELL CASING	223	ROTOR CORE ASSEMBLY		

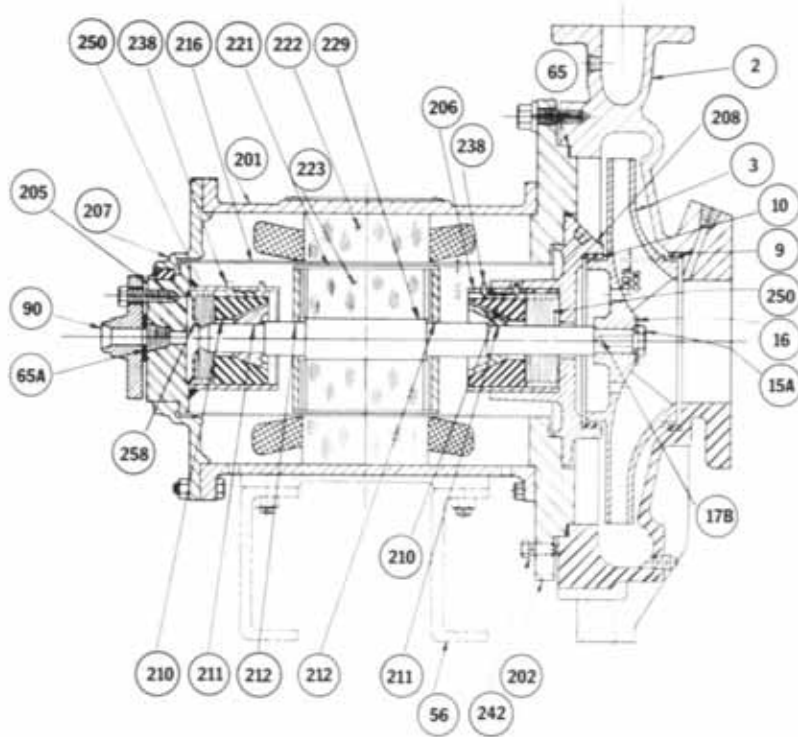

CONICAL BEARING DESIGN

Conical bearings of self-lubricating carbon graphite construction are used on motors built in motor frames P8, P66, P215 and PL215. Conical bearings have an internal taper to fit the tapered journals on the rotor. Stainless steel coil springs at each bearing maintain direct contact between the bearing and the journal, automatically compensating for bearing wear. A retaining clip prevents rotation of the conical bearing within the bearing housing. The pumped fluid circulated around the bearings serves to maintain bearing temperatures at a level which permits self-lubrication.

Conical Bearing Detail

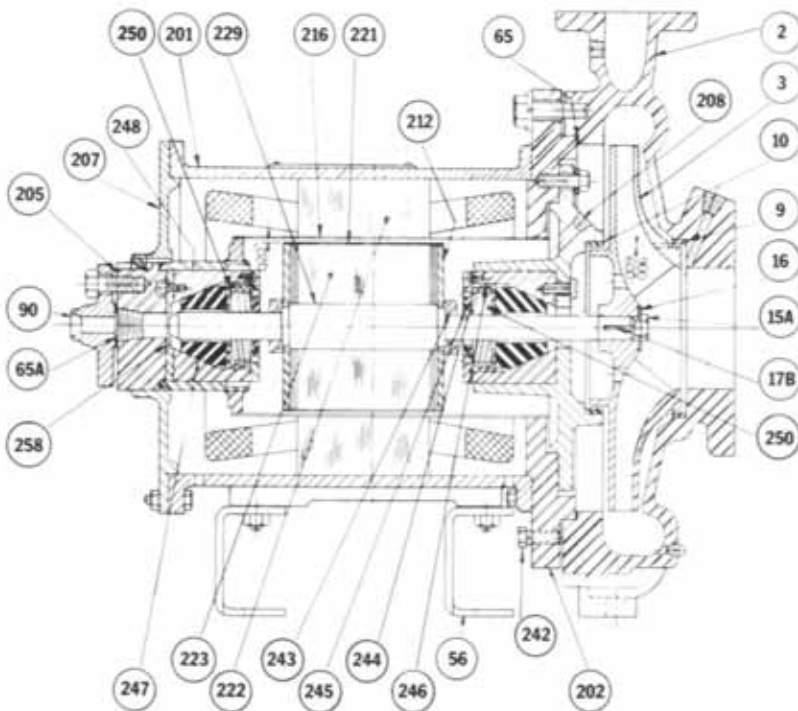
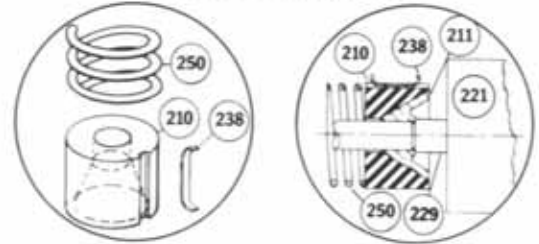

SEGMENTED BEARING DESIGN

Segmented bearings of self-lubricating carbon graphite construction are used on motors built in motor frames P-254, P-256X and P-256Z. Segmented bearings have an external taper to fit the tapered bearing housings. Stainless steel coil springs and spring retainer at each bearing maintain direct contact between the bearing, bearing housing, and straight rotor journal, which is Stellite. This type of bearing construction is used on motors for the above motor frames to reduce bearing peripheral speeds and to accommodate heavier bearing loads.

Segmented Bearing Detail

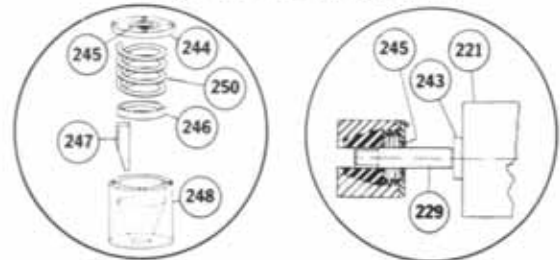

PERFORMANCE DATA HCR
3500 RPM

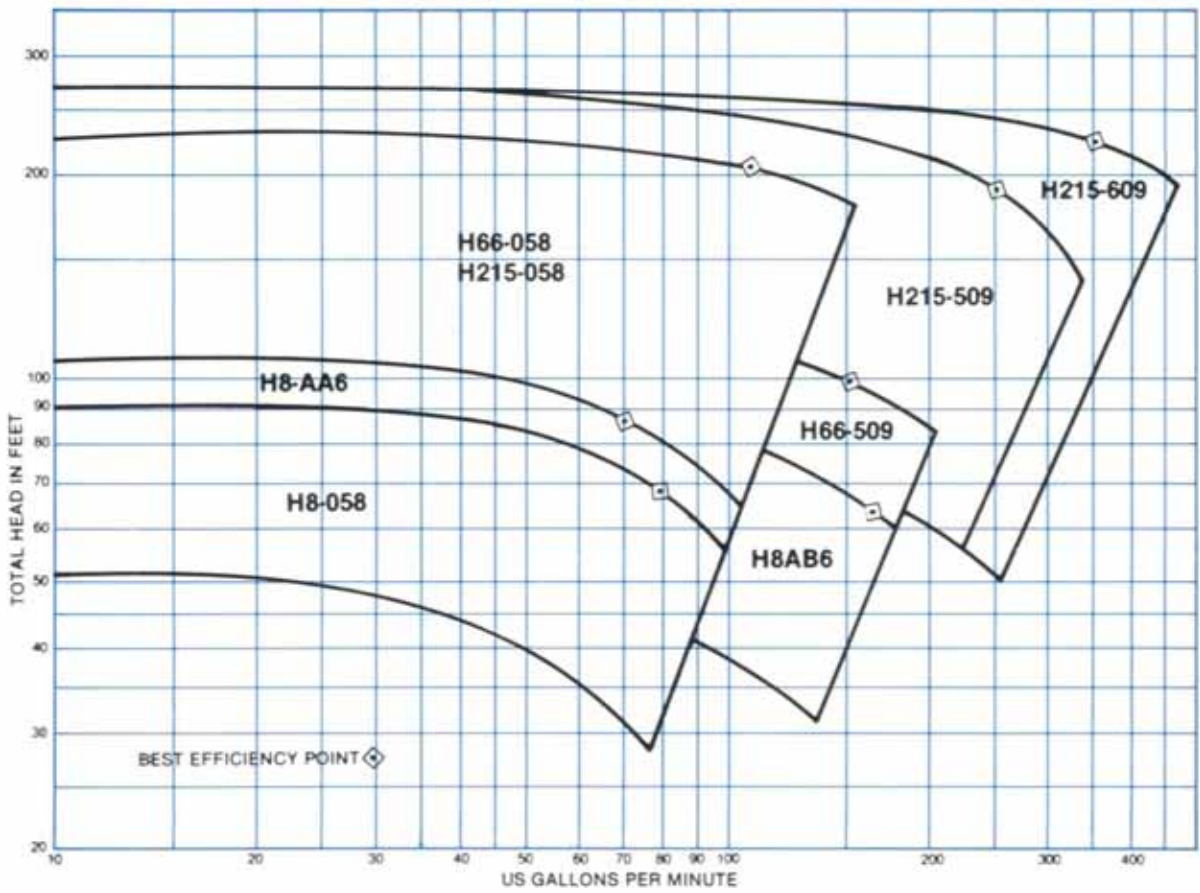

PERFORMANCE DATA HCR
1750 RPM

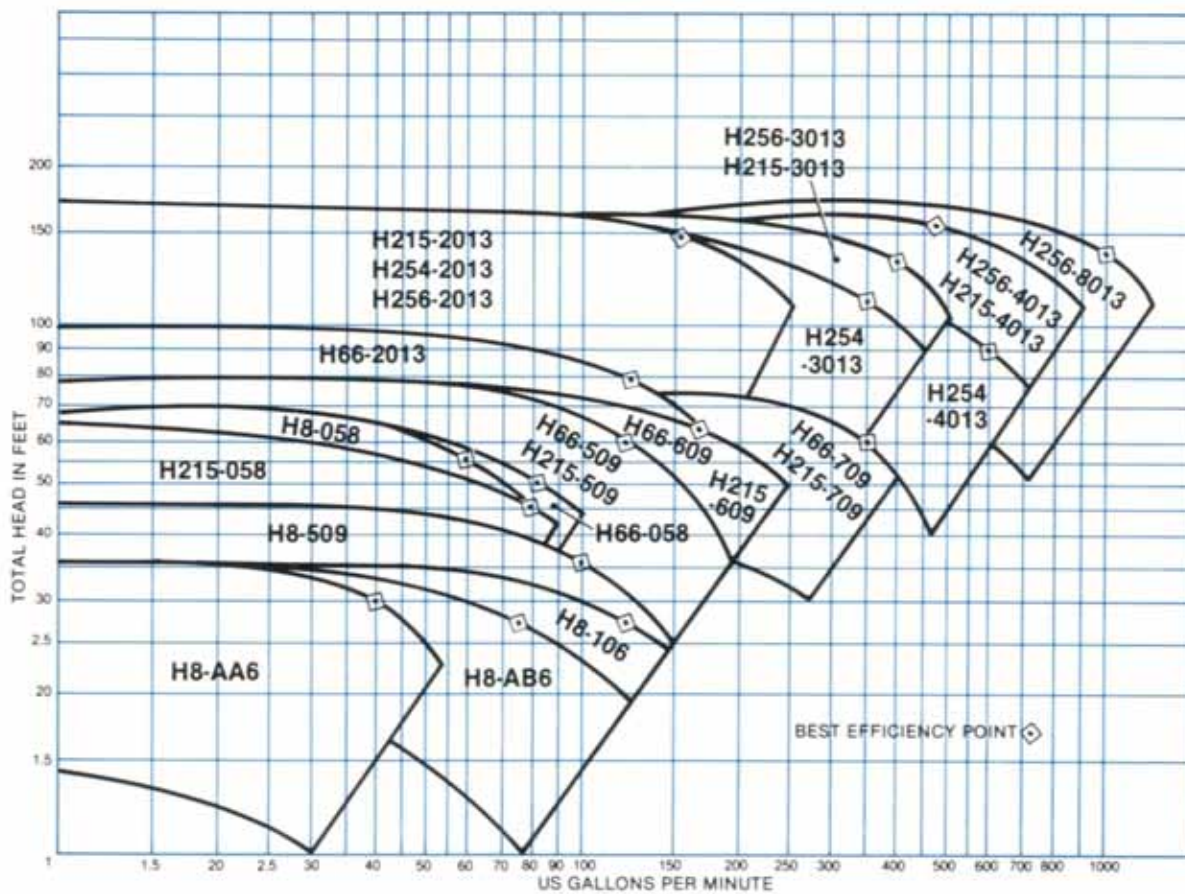

CAN-O-MATIC® THE RELIABLE ZERO LEAKAGE PUMPS

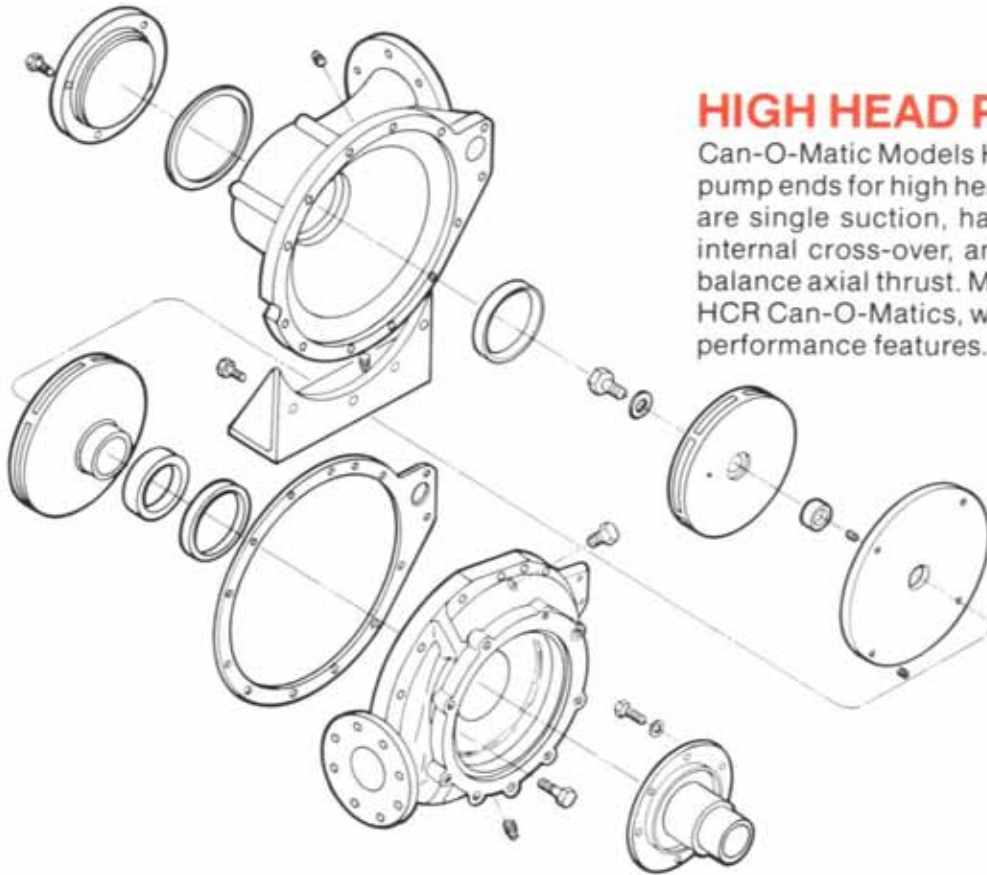

HIGH HEAD PERFORMANCE

Can-O-Matic Models HFF and HFFA have two-stage pump ends for high head applications. These pumps are single suction, have vertical split casings with internal cross-over, and opposed impellers to help balance axial thrust. Motors are the same as used on HCR Can-O-Matics, with identical construction and performance features.

SPECIFICATIONS

Head: to 480 feet
 Working Pressure: to 400 psi
 Temperature Range: -120° F to +490° F
 Motor Horsepower: 5 to 20 H.P.
 Materials of construction: Ductile iron, ductile iron/316ss fitted and all 316ss

PERFORMANCE DATA 2-STAGE FF & FFA
1750 RPM

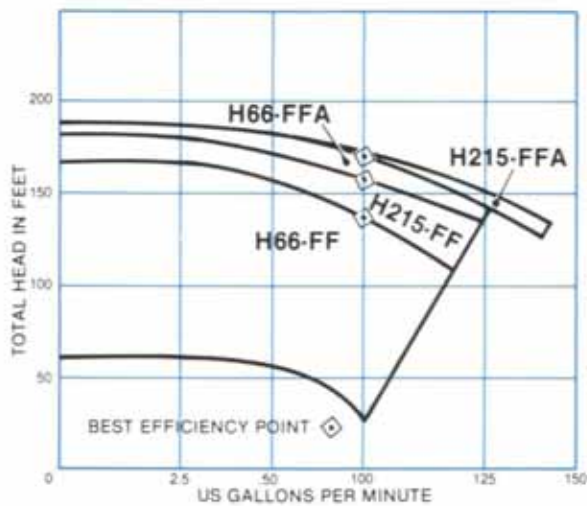

PERFORMANCE DATA 2-STAGE FF
3500 RPM

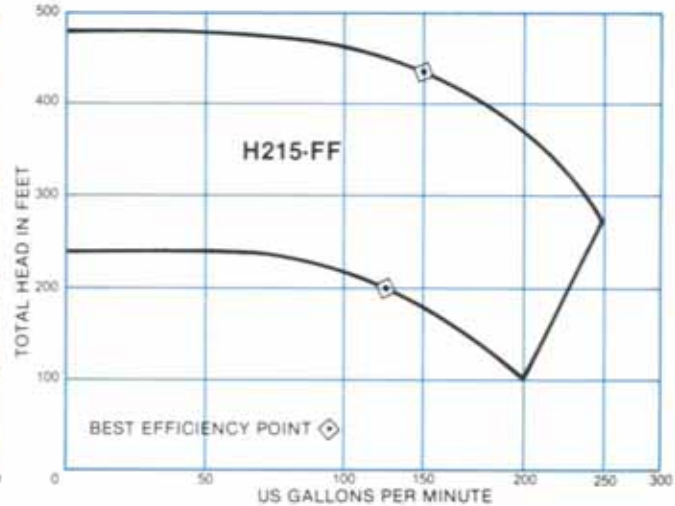

CAN-O-MATIC® THE RELIABLE ZERO LEAKAGE PUMPS

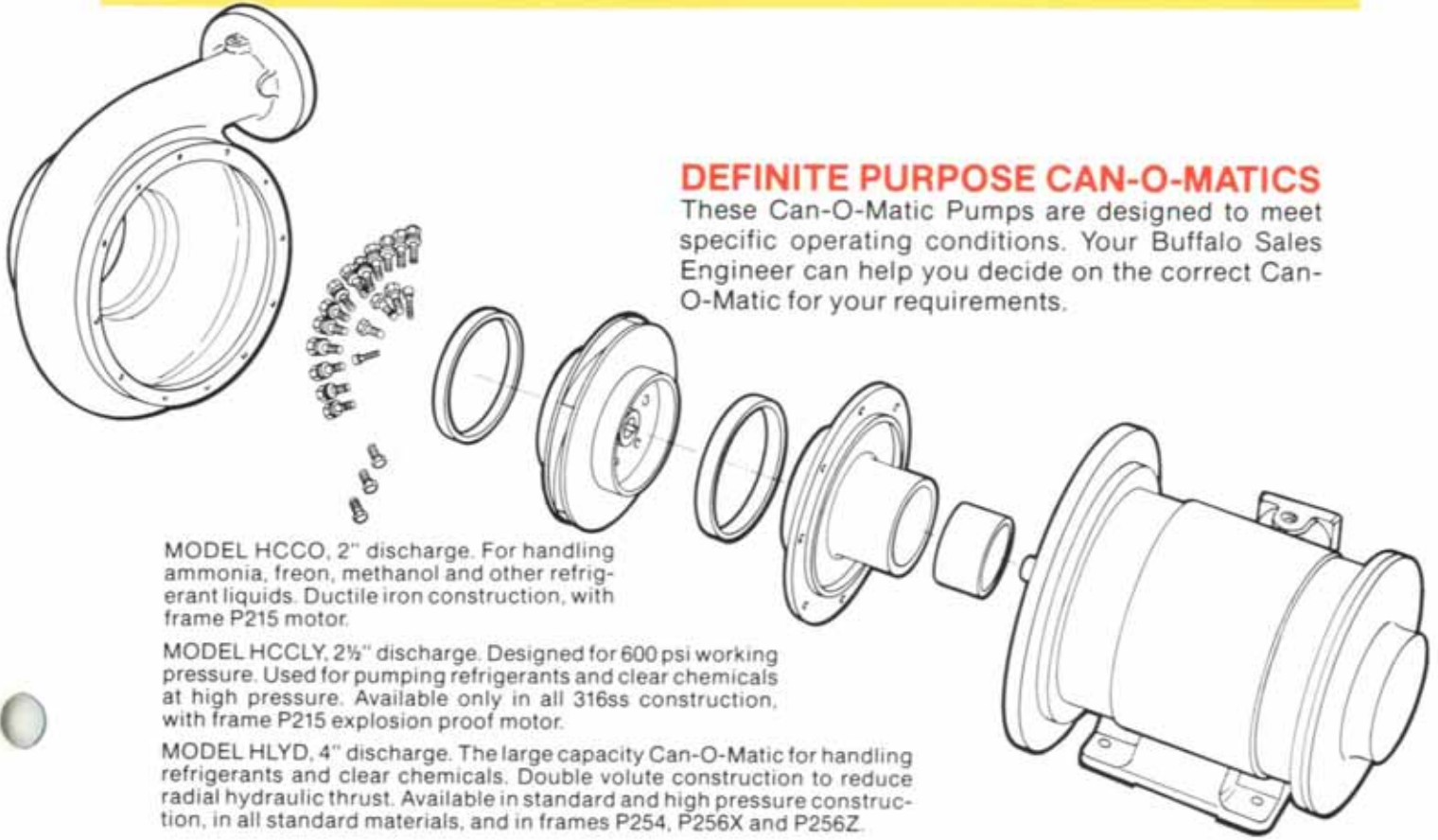

DEFINITE PURPOSE CAN-O-MATICS

These Can-O-Matic Pumps are designed to meet specific operating conditions. Your Buffalo Sales Engineer can help you decide on the correct Can-O-Matic for your requirements.

MODEL HCCO, 2" discharge. For handling ammonia, freon, methanol and other refrigerant liquids. Ductile iron construction, with frame P215 motor.

MODEL HCCLY, 2½" discharge. Designed for 600 psi working pressure. Used for pumping refrigerants and clear chemicals at high pressure. Available only in all 316ss construction, with frame P215 explosion proof motor.

MODEL HLYD, 4" discharge. The large capacity Can-O-Matic for handling refrigerants and clear chemicals. Double volute construction to reduce radial hydraulic thrust. Available in standard and high pressure construction, in all standard materials, and in frames P254, P256X and P256Z.

PERFORMANCE DATA HCCO, HCCLY, HLYD 1750 RPM



GENERAL SPECIFICATIONS "HCR" PUMPS

PUMPS

CAPACITIES TO -1200 GPM
TOTAL HEADS TO -225 FT

WORKING PRESSURES

200 PSI 150 PSI FF FLANGES
300 PSI 300 PSI FF FLANGES
400 PSI 300 PSI FF FLANGES

TEMPERATURES: VS INSULATION LIMITS

MINIMUM LIQUID -120° F
MAXIMUM LIQUID CLASS H - INSULATION +370° F
MAXIMUM LIQUID CLASS C - INSULATION +490° F

PUMPS AVAILABLE FOR PUMPED LIQUID TEMPERATURES
UP TO MAXIMUM DEPENDING ON HP/RPM CONDITIONS.
MAXIMUM VISCOSITY OF PUMPED FLUID 200 SSU.

MOTORS

HORSEPOWERS 1½ - 40
VOLTAGES: 3 phase 60 cycles
208-480 volts
3 phase 50 cycles
180-416 volts

ENCLOSURES:

- 1) Totally enclosed, liquid cooled - standard
- 2) Totally enclosed, liquid cooled explosion
Proof Class I Group D
Division I (No. U.L. label) - optional

STANDARD MATERIALS OF CONSTRUCTION

PART	DUCTILE IRON CAST IRON FITTED	DUCTILE IRON BRONZE FITTED	DUCTILE IRON 316 ST. STL. FITTED	ALL 316 ST. STL.	PART NO.
CASING	DUCTILE IRON	DUCTILE IRON	DUCTILE IRON	316 ST. STL.	2
IMPELLER	CAST IRON	BRONZE	316 ST. STL.	316 ST. STL.	3
CASING RING	CARBON GRAPHITE	CARBON GRAPHITE	CARBON GRAPHITE	CARBON GRAPHITE	9
MOTOR RING	CARBON GRAPHITE	CARBON GRAPHITE	CARBON GRAPHITE	CARBON GRAPHITE	10
IMP. LOCK SCREW	316 ST. STL.	316 ST. STL.	316 ST. STL.	316 ST. STL.	15A
IMP. WASHER	316 ST. STL.	316 ST. STL.	316 ST. STL.	316 ST. STL.	16
FEATHER KEY	316 ST. STL.	316 ST. STL.	316 ST. STL.	316 ST. STL.	17B
ADAPTER (b)	STEEL (a)	STEEL (a)	STEEL (a)	316 ST. STL.	60
MOTOR FLANGE	STEEL (a)	STEEL (a)	STEEL (a)	316 ST. STL.	202
BEARING HOUSING	316 ST. STL.	316 ST. STL.	316 ST. STL.	316 ST. STL.	205, 248
WEAR RNG HOUSING	CAST IRON (a)	CAST IRON (a)	CAST IRON (a)	316 ST. STL.	208
BEARINGS (d)	CARBON GRAPHITE	CARBON GRAPHITE	CARBON GRAPHITE	CARBON GRAPHITE	247, 210
JOURNALS (c)	316 ST. STL.	316 ST. STL.	316 ST. STL.	316 ST. STL.	211
STATOR CAN	316 ST. STL.	316 ST. STL.	316 ST. STL.	316 ST. STL.	216
MOTOR CAN	316 ST. STL.	316 ST. STL.	316 ST. STL.	316 ST. STL.	221
MOTOR SHAFT	316 ST. STL.	316 ST. STL.	316 ST. STL.	316 ST. STL.	229
SPRINGS	316 ST. STL.	316 ST. STL.	316 ST. STL.	316 ST. STL.	250
THRUST-O-MATIC ORIFICE	316 ST. STL.	316 ST. STL.	316 ST. STL.	316 ST. STL.	258
BEARING HOUSING INSERT	316 ST. STL.	316 ST. STL.	316 ST. STL.	316 ST. STL.	206
RETAINING CLIP (BEARING)	316 ST. STL.	316 ST. STL.	316 ST. STL.	316 ST. STL.	238

a) 316 STAINLESS STEEL ON FRAME P8

b) USED ON H8-058, H8-509, H66-2013, and H66-3013

c) STELLITE 40 ON FRAMES P215, P254, P256X, and P256Z

d) CONICAL BEARINGS FRAMES P8 to P215, SEGMENTED BEARINGS FRAMES P254, P256X, and P256Z
FOR OTHER MATERIALS OF CONSTRUCTION, HIGHER TEMPERATURES OR HIGHER PRESSURES -
CONSULT WITH BUFFALO PUMP ENGINEERING

TEMPERATURE CAPABILITIES - STANDARD MOTORS

FRAME	NOMINAL HP	RPM	RATED HP	WORKING PRESSURE PSI		COOLING BY NATURAL CONVECTION	MAXIMUM LIQUID TEMP		MAXIMUM LIQUID TEMP AT EXTENDED HP		
				STD	HIGH		CLASS H	CLASS C	HP	CLASS H	CLASS C
P 8	1½ 3	1750 3600	1½ 3	200	300	Ambient Air	352F	430F	2	180F	220F
							363F	453F			
P 66	5	1750	1	200	300	Ambient Air	363F	455F	6	135F	180F
			2				345F	437F			
	3	325F	412F								
	5	275F	370F								
P 66	5	3600	1	200	300	Ambient Air	370F	450F	6	160F	200F
			2				363F	442F			
	3	354F	433F								
	5	325F	401F								
P 215	10	1750	5	200	400	Ambient Air	358F	435F	15	165F	230F
			7½				342F	417F			
	10	325F	400F								
	5	325F	403F								
P 215	10	3600	7½	200	400	Ambient Air	300F	375F	15	155F	215F
			10				260F	340F			
	5	325F	403F								
	5	300F	375F								
PL 215	20	1750	7½	400	Ambient Air	NA	442F	NONE	NA	NA	
			10			NA	407F				
	15	NA	348F								
	20	NA	246F								
PL 215	20	3500	7½	400	Ambient Air	NA	376F	NONE	NA	NA	
			10			NA	359F				
	15	NA	310F								
	20	NA	239F								
P 254	15	1750	7½	400	Ambient Air	NA	430F	20	NA	195F	
			10			NA	406F				
	15	NA	400F								
	7½	NA	481F								
P 254	15	1750	10	400	Fan Cooling	NA	478F	20	NA	235F	
			15			NA	464F				
	7½	NA	464F								
	15	NA	464F								
P 256X	25	1750	15	400	Ambient Air	NA	422F	35	NA	145F	
			20			NA	400F				
	25	NA	350F								
	15	NA	491F								
P 256X	25	1750	20	400	Fan Cooling	NA	464F	35	NA	190F	
			25			NA	422F				
	15	NA	422F								
	25	NA	422F								
P 256Z	40	1750	25	400	Ambient Air	NA	412F	50	NA	150F	
			30			NA	368F				
	40	NA	338F								
	25	NA	469F								
P 256Z	40	1750	20	400	Fan Cooling	NA	430F	50	NA	190F	
			40			NA	404F				

CAN-O-MATIC® THE RELIABLE ZERO LEAKAGE PUMPS

DIMENSIONS

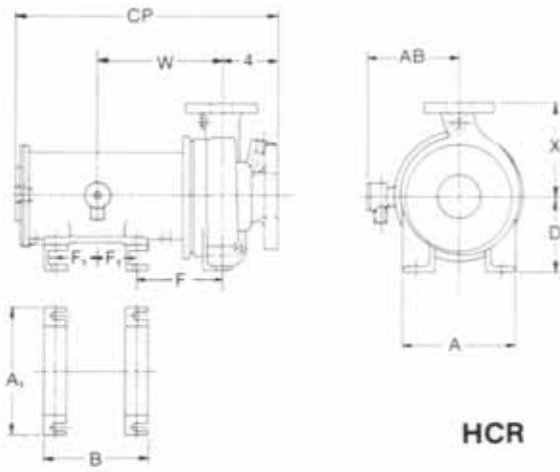

HCR

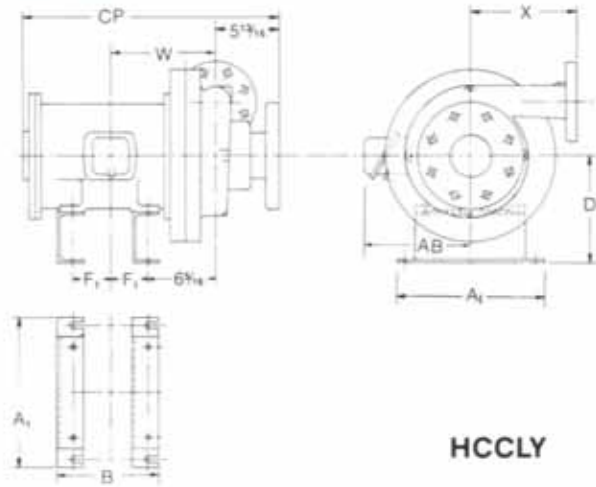

HCCLY

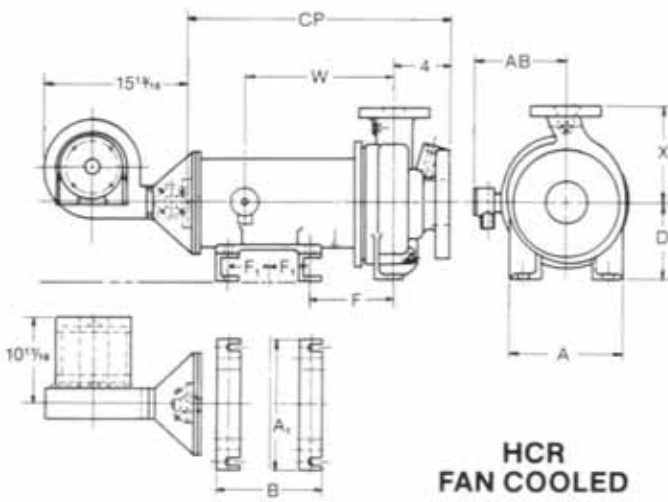

**HCR
FAN COOLED**

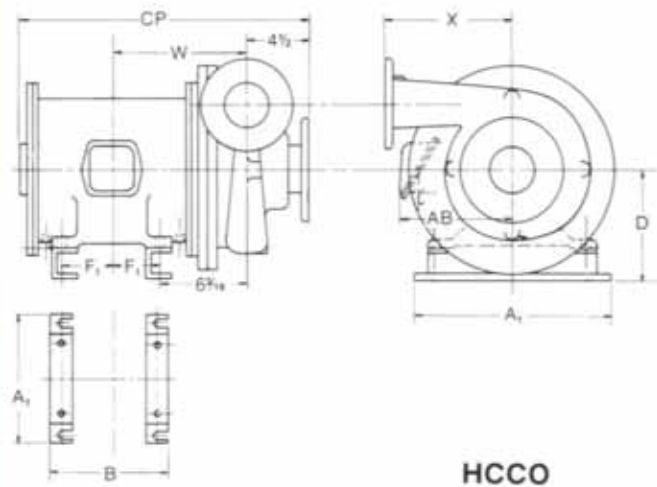

HCCO

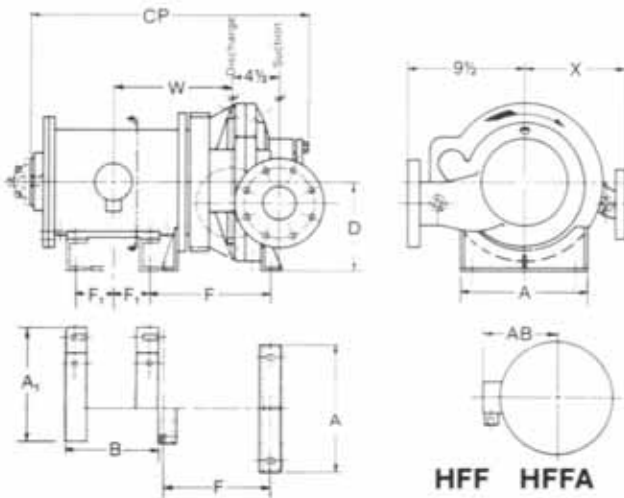

HFF HFFA

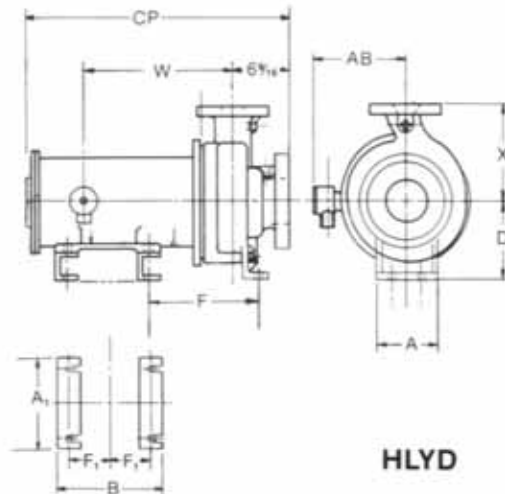

HLYD

CAN-O-MATIC® THE RELIABLE ZERO LEAKAGE PUMPS

DIMENSIONS HCR HFF HCCLY HCCO HLYD

		PUMP MODEL	SUC-TION	DIS-CHARGE	CP	A	D	X	W	AB	B	A ₁	F	F ₁
HCR	H8	AA6	1½	1	18½	8	5½	6½	12½ ₃₂	6½ ₁₆	—	—	—	—
"	H8	AB6	3	1½	18½	8	5½	6½	12½ ₃₂	6½ ₁₆	—	—	—	—
"	H8	106	3	2	18½	8	5½	8½	12½ ₃₂	6½ ₁₆	—	—	—	—
"	H8	058	2	1	18½ ₃₂	11½	8½	8½	12½ ₁₆	6½ ₁₆	—	—	—	—
"	H8	509	3	1½	18½ ₃₂	11½	8½	8½	12½ ₁₆	6½ ₁₆	—	—	—	—
"	H66	058	2	1	18½ ₁₆	11½	8½	8½	13	7½ ₁₆	—	—	—	—
"	H66	509	3	1½	18½ ₁₆	11½	8½	8½	13	7½ ₁₆	—	—	—	—
"	H66	609	3	2	18½ ₁₆	11½	8½	9½	13	7½ ₁₆	—	—	—	—
"	H66	709	4	3	18½ ₁₆	11½	8½	11	13	7½ ₁₆	—	—	—	—
"	H66	2013	3	1½	18½ ₁₆	11½	10	10½	13	7½ ₁₆	—	—	—	—
HCR	H215	058	2	1	20½	11½	8½	8½	8½ ₁₆	9½ ₁₆	9½	14	5½ ₁₆	3½
"	HL215	058	2	1	20½	11½	8½	8½	8½ ₁₆	9½ ₁₆	9½	14	5½ ₁₆	3½
"	H215	509	3	1½	20½	11½	8½	8½	8½ ₁₆	9½ ₁₆	9½	14	5½ ₁₆	3½
"	HL215	509	3	1½	20½	11½	8½	8½	8½ ₁₆	9½ ₁₆	9½	14	5½ ₁₆	3½
"	H215	609	3	2	20½	11½	8½	9½	8½ ₁₆	9½ ₁₆	9½	14	5½ ₁₆	3½
"	HL215	609	3	2	20½	11½	8½	9½	8½ ₁₆	9½ ₁₆	9½	14	5½ ₁₆	3½
"	H215	709	4	3	20½	11½	8½	11	8½ ₁₆	9½ ₁₆	9½	14	5½ ₁₆	3½
"	HL215	709	4	3	20½	11½	8½	11	8½ ₁₆	9½ ₁₆	9½	14	5½ ₁₆	3½
"	H215	2013	3	1½	20½	11½	10	10½	8½ ₁₆	9½ ₁₆	9½	14	5½ ₁₆	3½
"	HL215	2013	3	1½	20½	11½	10	10½	8½ ₁₆	9½ ₁₆	9½	14	5½ ₁₆	3½
"	H215	3013	3	2	20½	11½	10	11½	8½ ₁₆	9½ ₁₆	9½	14	5½ ₁₆	3½
"	HL215	3013	3	2	20½	11½	10	11½	8½ ₁₆	9½ ₁₆	9½	14	5½ ₁₆	3½
"	H215	4013	4	3	20½	11½	10	12½	8½ ₁₆	9½ ₁₆	9½	14	5½ ₁₆	3½
"	HL215	4013	4	3	20½	11½	10	12½	8½ ₁₆	9½ ₁₆	9½	14	5½ ₁₆	3½
HCR	H254	2013	3	1½	21½	11½	10	10½	9½ ₃₂	10	10½	15½	5½ ₁₆	4½
"	H254	3013	3	2	21½	11½	10	11½	9½ ₃₂	10	10½	15½	5½ ₁₆	4½
"	H254	4013	4	3	21½	11½	10	12½	9½ ₃₂	10	10½	15½	5½ ₁₆	4½
"	H254	8013	6	4	21½	14	10	13½	9½ ₃₂	10	10½	15½	5½ ₁₆	4½
HCR	H256	2013	3	1½	28	11½	10	10½	19½ ₁₆	10½ ₁₆	10½	15½	8½	4½
"	H256	3013	3	2	28	11½	10	11½	19½ ₁₆	10½ ₁₆	10½	15½	8½	4½
"	H256	4013	4	3	28	11½	10	12½	19½ ₁₆	10½ ₁₆	10½	15½	8½	4½
"	H256	8013	6	4	28	14	10	13½	19½ ₁₆	10½ ₁₆	10½	15½	8½	4½
HFF	H66	HFF	3	2	23½ ₁₆	12	8½	9½	15½ ₁₆	7½ ₁₆	—	—	9½ ₁₆	—
"	H66	HFFA	3	2	23½ ₁₆	12	8½	9½	15½ ₁₆	7½ ₁₆	—	—	9½ ₁₆	—
"	H215	HFF	3	2	25½	12	8½	9½	10½	9½ ₁₆	9½	14	10½	3½
"	HL215	HFF	3	2	25½	12	8½	9½	10½	9½ ₁₆	9½	14	10½	3½
"	H215	HFFA	3	2	25½	12	8½	9½	10½	9½ ₁₆	9½	14	10½	3½
"	HL215	HFFA	3	2	25½	12	8½	9½	10½	9½ ₁₆	9½	14	10½	3½
HCCLY	H215	HCCLY	4	2½	23½ ₁₆	—	10	9½ ₁₆	9½ ₁₆	9½ ₁₆	9½	14	—	3½
HCCO	H215	HCCO	3	2	22	—	10	9½	9½ ₁₆	9½ ₁₆	8½	14	—	3½
HLYD	H254	HLYD	6	4	24½ ₁₆	7	12	16	9½ ₃₂	10	9½ ₃₂	12	8½	4½
"	H256	HLYD	6	4	31	7	12	16	20	10½ ₁₆	10½	12	12½ ₁₆	4½

SUCTION AND DISCHARGE FLANGE DIMENSIONS

ALL MODELS EXCEPT HLYD

PRESSURE	STANDARD						HIGH (OPTIONAL)						HLYD PUMP STD. 175# W.P.		
	1"	1½"	2"	3"	4"	6"	1"	1½"	2"	2½"	3"	4"	6"	4"	6"
SIZE	1"	1½"	2"	3"	4"	6"	1"	1½"	2"	2½"	3"	4"	6"	4"	6"
FLANGE DIA.	4½"	5"	6"	7½"	9"	11"	4½"	6½"	6½"	7½"	8½"	10"	12½"	10"	12½"
THICKNESS	¾"	1½"	¾"	1½"	1½"	—	1½"	1½"	¾"	1"	1½"	1½"	1½"	1½"	1½"
NO. & SIZE BOLTS	4½"	4½"	4"	4"	8"	8"	4"	4"	8"	8"	8"	8"	12½"	8"	8"
BOLT CIRCLE	3½"	3½"	4½"	6"	7½"	9½"	3½"	4½"	5"	5½"	6½"	7½"	10½"	7½"	9½"

Sales Representatives

ALBANY, NY
ALBUQUERQUE, NM
ALLENTOWN, PA
ATLANTA, GA
BALTIMORE (SEVERNA PARK), MD
BIRMINGHAM, AL
BOSTON (WAKEFIELD), MA
BUFFALO (ORCHARD PARK), NY
CHICAGO (WHEELING), IL
CINCINNATI, OH
CLEVELAND, OH
COLUMBUS, OH
DALLAS (RICHARDSON), TX
DENVER (ENGLEWOOD), CO
DES MOINES, IA
DETROIT (FARMINGTON HILLS), MI
FLORIDA (MIAMI), FL
(TAMPA)
(JACKSONVILLE)
GREENSBORO, NC
GREENVILLE, SC
HARTFORD (AVON), CT
HOUSTON, TX
INDIANAPOLIS, IN
KANSAS CITY, MO
KNOXVILLE, TN
LOS ANGELES
(SANTA FE SPRINGS), CA
LOUISVILLE, KY
MEMPHIS, TN
MILWAUKEE, WI
MINNEAPOLIS
(BLOOMINGTON), MN
NEW ORLEANS, LA
NEW YORK (E. NORWALK, CT)
NORTHERN NEW JERSEY
(PLUCKEMIN), NJ
OKLAHOMA CITY, OK
PHILADELPHIA (WYNNEWOOD), PA
PHOENIX, AZ
PITTSBURGH, PA
RICHMOND, VA
ROCHESTER, NY
ST. LOUIS, MO
SALT LAKE CITY, UT
SAN ANTONIO, TX
SAN FRANCISCO
(EMERYVILLE), CA
SEATTLE (BELLEVUE), WA
SYRACUSE, NY
TOLEDO (PERRYSBURG), OH
TULSA, OK
WASHINGTON, D.C.
(ROCKVILLE, MD)
(ALEXANDRIA, VA)
SOUTHERN REGIONAL PUMP OFFICE
ATLANTA (EAST POINT), GA

In Canada:

CALGARY, ALTA.
EDMONTON, ALTA.
HAMILTON, ONT.
KITCHENER, ONT.
MONTREAL, QUE.
OTTAWA, ONT.
SAINT JOHN, N.B.
SARNIA, ONT.
SASKATOON, SASK.
TORONTO, ONT.
VANCOUVER, B.C.
WINNIPEG, MAN.

In Mexico:

GUADALAJARA, JAL.
MEXICO CITY, D.F.
MONTERREY, N.L.

OTHER BUFFALO PUMPS

BUFFALO "SH" SOLIDS HANDLING PUMPS

These industrial solids handling pumps are available in horizontal, vertical non-submerged, vertical submerged and close coupled models. Sizes to handle up to 4" solids. Capacities to 6000 gpm. Pressures to 100 psi. Heads to 225'. Bulletin 964.

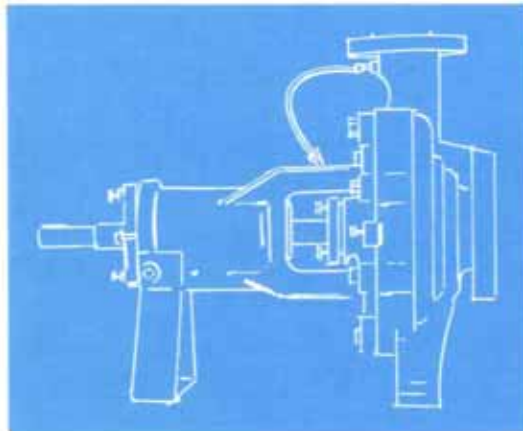
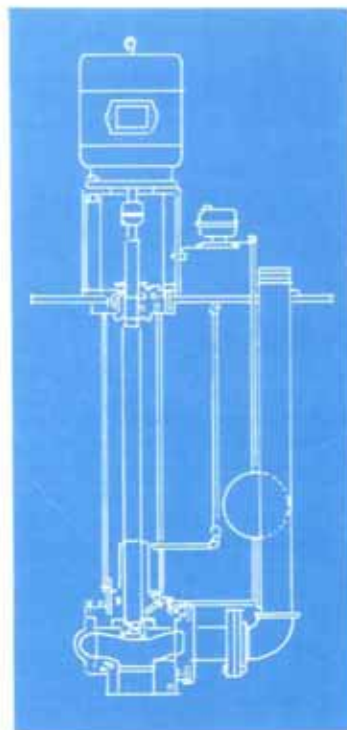

4-WAY FRAME MOUNTED PUMP

Buffalo 4-Way Pumps are designed to operate with reduced axial and radial loads for long maintenance-free service in the chemical process and allied industries. 21 sizes. Capacities to 5000 gpm. Pressures to 300 psi. Bulletin 903.

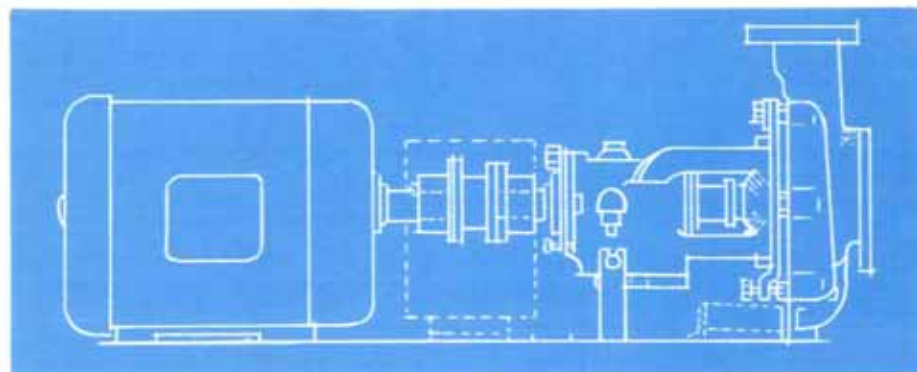

VORTEX PUMPS

Designed to handle abrasive slurries and solids, this new line of vortex type pumps features an adjustable, replaceable vane impeller. One impeller hub size and three vane lengths provide impeller diameters from 7" to 13" at 1/2" increments. Adjustability feature provides modification of pump output and compensation for wear. Capacities to 2000 gpm. Heads to 190 ft. Bulletin 902. PATENT PENDING.

buffalo pumps



BUFFALO, NEW YORK 14240-0985

