



BY JOHNSON CONTROLS

**AIR-COOLED LIQUID CHILLERS
HERMETIC SCROLL**

RENEWAL PARTS

Supercedes: 150.67-RP1 (310)

Form: 150.67-RP1 (511)

**MODELS YCAL0019, 0022, 0028, 0033, 0043, 0046, 0052,
0056, AND 0066**



50091

STYLE "E"



R-410A
15 - 60 TON
53 - 218 Kw
50Hz and 60Hz

Issue Date:
May 18, 2011



200-3-60
230-3-60
315-3-60
380/415-50
460-3-60
575-3-60
MODELS ONLY

CHANGEABILITY OF THIS DOCUMENT

In complying with Johnson Controls policy for continuous improvement, the information contained in this document is subjected to change without notice. While Johnson Controls makes no commitment to update or provide current information automatically to the manual user, that information, if applicable, can be obtained by contacting the nearest Johnson Controls Engineered Systems Service office.

It is the responsibility of operating/service personnel as to the applicability of these documents to the equipment in question. If there is any question in the mind of operating/ service personnel as to the applicability of these documents, then, prior to working on the equipment, they should verify with the owner, whether the equipment has been modified and if the current literature is available.

WARNING

HIGH VOLTAGE

Is used in the operation of this equipment.

DEATH OR SERIOUS INJURY

may result if personnel fail to observe safety precautions.

Work on electronic equipment should not be undertaken unless the individual(s) have been trained in the proper maintenance of equipment and is (are) familiar with its potential hazards.

Shut off power supply to the equipment before beginning work and follow lockout procedures. When working inside equipment with power off, take care to discharge every capacitor likely to hold dangerous potential.

Be careful not to contact high voltage connections when installing or operating this equipment.

LOW VOLTAGE

DO NOT be misled by the term "low voltage." Voltages as low as 50 volts may cause death.

TABLE OF CONTENTS

Table 1 - SWEP HEAT EXCHANGER - STANDARD INSULATION	5
Table 2 - SWEP HEAT EXCHANGER - DOUBLE INSULATION	7
Table 3 - SWEP HEAT EXCHANGER PARTS (STANDARD AND DOUBLE INSULATION) YCAL0019 - YCAL0033.....	9
Table 4 - SWEP HEAT EXCHANGER AND TXV PARTS (STANDARD AND DOUBLE INSULATION) YCAL0043 - YCAL0066.....	10
Table 5 - ALFA LAVAL HEAT EXCHANGER AND RELATED COMPONENTS	12
Table 6 - CONDENSER COIL COMPONENTS.....	15
Table 7 - CONDENSER COIL COMPONENTS.....	16
Table 8 - FAN COMPONENTS - MODELS YCAL0019 and YCAL0022	17
Table 9 - FAN COMPONENTS - YCAL0028, 0033, 0043, 0046, 0052, 0056 & YCAL0066.....	18
Table 10 - REFRIGERANT PIPING COMPONENTS	19
Table 11 - RECOMMENDED OIL TYPE	27
Table 12 - R-410A COMPRESSOR PART NUMBERS.....	27
Table 13 - COMPRESSOR HEATER AND COMPRESSOR SOUND BLANKET PART NUMBERS	29
Table 14 - OPTION PANEL AND POWER PANEL CONFIGURATIONS	31
Table 15 - CONTROL PANEL AND POWER PANEL IDENTIFIERS	33
Table 16 - CONTROL AND POWER PANEL COMPONENTS	34
Table 17 - CONTROL WIRING HARNESSSES.....	51
Table 18 - SENSOR HARNESS WIRING	52
Table 19 - TEMPERATURE SENSORS AND TRANSDUCERS.....	53
Table 20 - TRANSDUCER AND THERMISTOR WIRE HARNESS CONNECTORS - FIELD REPLACEMENT PARTS.....	54
Table 21 - WIRE KIT OPTIONS	55
Table 22 - WIRE ENCLOSURE PARTS	55
Table 23 - LOUVERED ENCLOSURE PARTS	56
Table 24 - ENCLOSURE KIT OPTIONS	57
Table 25 - WIRE ENCLOSURE PARTS	57
Table 26 - LOUVERED ENCLOSURE PARTS	58
Table 27 - VIBRATION ISOLATORS PART NUMBERS	59
Table 28 - FIELD INSTALLED OPTIONS KIT NUMBERS	60
Table 29 - CONTROL TRANSFORMER KIT	60
Table 30 - OPTIVIEW REMOTE CONTROL CENTER PARTS.....	61
Table 31 - REMOTE RESET WIRING	62
Table 32 - REMOTE TEMPERATURE RESET KIT COMPONENTS	62
Table 33 - RECOMMENDED SPARE PARTS - YCAL STYLE 'E' CHILLERS.....	63

UNIT NOMENCLATURE NAMEPLATE ENGINEERING DATA

BASIC PART NUMBER

YCAL0062EC28XDA

1	2	3	4	5	6	7	8	9	10	11	12	13	14	15
BASE PRODUCT TYPE				NOMINAL CAPACITY				UNIT DESIGNATOR	REFRIGERANT	VOLTAGE/STARTER			DESIGN/DEVELOPMENT LEVEL	
Y	C	A	L	#	#	#	#	E	E	1	7		E	
: YORK : Chiller : Air Cooled L : Scroll				Tons/Kw 0019 to 0066				High Efficiency	:R-410A	:200/3/60 :230/3/60 :380/3/60 :460/3/60 :385-415/3/50 :575/3/60 X :Across the Line			:Design Series E :Engineering Change or PIN Level	

PART NUMBER – LETTER CODES

16 17 18 19 POWER FIELD

S	X			
S	D			
B	X			
		T		
			C	

MP = Multiple Point
SP = Single Point
NFDS = Non-Fused Disconnect Switch
TB = Terminal Block
Ser. = Service
CB = Circuit Breaker

20 21 22 23 24 25 26 27 28 CONTROLS FIELD

L	H	A						
		M						
		S	F					
		G						
			R					
				L				
					C			
						O		
							S	

29 30 31 32 33 34 35 36 37 COMPRESSOR / PIPING FIELD

#	#							
T	S							
		C						
		S						
		B						
				1				
				2				
								X

38 39 40 41 42 43 44 EVAP. FIELD

3		D					
			X				
			V				
				S			
				T			
				U			
				D			
				E			
				F			
					A		
						R	

55 EXTENDED FIELD WARRANTY

X	
B	
C	
D	
E	
F	
G	
H	

45 46 47 CONDENSER FIELD

X		
C		
B		
P		
	X	

56
REFRIGERANT WARRANTY

1	: 1 Year Refrigerant
2	: 2 Year Refrigerant
5	: 5 Year Refrigerant

48 49 50 51 52 53 54 CABINET FIELD

1						
7						
	B					
			L			
				1		
				S		
				N		

60
PUMP PACKAGE OPTIONS

A	: 1-Pump
B	: 2-Pumps
C	: 1 Pump with Expansion Tank
D	: 2-Pumps with Expansion Tank
E	: 1-Pump with Buffer Tank
F	: 2-Pumps with Buffer Tank
G	: 1-Pump with Expansion Tank and Buffer Tank
H	: 2-Pumps with Expansion Tank and Buffer Tank

61
PLANT OF MANUFACTURE

R	: Plant Of Manufacture - Monterrey
CUR	: Curitiba, Brazil
MEX	: Mexico, ES
MTY	: Monterrey, BE
SAT	: San Antonio, Texas

NOTES:

1. Q :DENOTES SPECIAL / S.Q.
2. # :DENOTES STANDARD
3. X :w/in OPTIONS FIELD, DENOTES NO OPTION SELECTED
4. Agency Files (i.e. U.L. / ETL; CE; ARI; ETC.) will contain info. based on the first 14 characters only.
5. Plant of manufacture to include PIN 56 upon entering the chiller order.

SECTION 1 - SWEP HEAT EXCHANGER AND RELATED COMPONENTS

TABLE 1 - SWEP HEAT EXCHANGER - STANDARD INSULATION

ITEM	DESCRIPTION	HEAT EXCHANGER		PART NUMBER*	MODELS	QUANTITY	FIGURE
		STANDARD	REMOTE				
1	Heat Exchanger	X	X	375 94523 000	YCAL0019		1, 3, 4
		X	X	375 94525 000	YCAL0022, YCAL0028, YCAL0033	1	
		X	N/A	375 94531 000	YCAL0043	1	
		N/A	X	392 01184 000	YCAL0043, YCAL0052	1	
		X	N/A	375 94533 000	YCAL0046	1	
		N/A	X	392 01186 000	YCAL0046, YCAL0056	1	
		X	N/A	375 94535 000	YCAL0052	1	
		X	N/A	375 94537 000	YCAL0056	1	
		X	N/A	375 94539 000	YCAL0066	1	
N/A	X	392 01188 000	YCAL0066	1			
5	Heater, 120 Volts, 100 Watts	X	N/A	025 40572 000	ALL	1	1, 3, 4
6	Cover Water Side	X	X	075 70428 112	YCAL0019, YCAL0022, YCAL0028, YCAL0033	1	1, 3, 4
	Cover Water Side	X	X	075 70428 141	YCAL0043, YCAL0046, YCAL0052, YCAL0056, YCAL0066	1	
7	Cover Refrigerant Side	X	X	075 70428 112	YCAL0019, YCAL0022, YCAL0028, YCAL0033	1	1, 3, 4
	Cover Refrigerant Side	X	X	075 70428 141	YCAL0043, YCAL0046, YCAL0052, YCAL0056, YCAL0066	1	
8	Cover (Standard Insulation)	X	X	075 70430 118	YCAL0019	1	1, 3, 4
	Cover (Standard Insulation)	X	X	075 70430 121	YCAL0022, YCAL0028, YCAL0033	1	
	Cover (Standard Insulation)	X	X	075 70430 155	YCAL0043, YCAL0052	1	
	Cover, (Standard Insulation)	X	X	075 70430 156	YCAL0046, YCAL0056	1	
	Cover (Standard Insulation)	X	X	075 70430 157	YCAL0066	1	

* Part numbers for heat exchangers include mounting bracket, wells and rails. On older YCAL's with Alfa Laval heat exchangers, piping modifications may be needed to install the SWEP heat exchangers. See "Figure 4 - SWEP HEAT EXCHANGER - (STANDARD AND DOUBLE INSULATION) YCAL0043 - YCAL0066" on page 11 and "Table 5 - ALFA LAVAL HEAT EXCHANGER AND RELATED COMPONENTS" on page 12 for Alfa Laval heat exchanger and related component part numbers. The TXV's are not included with the heat exchanger.

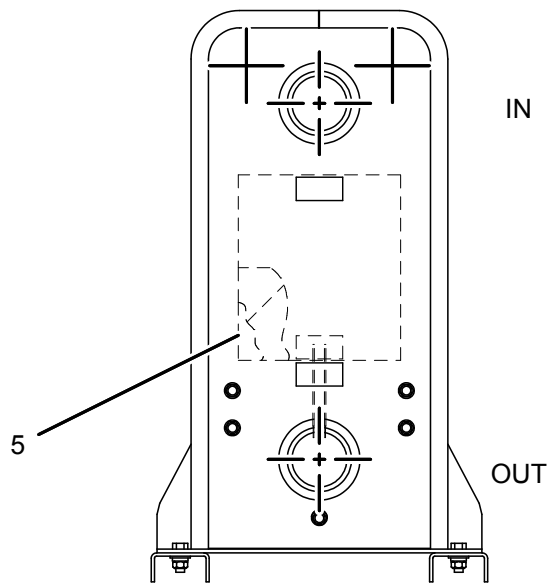
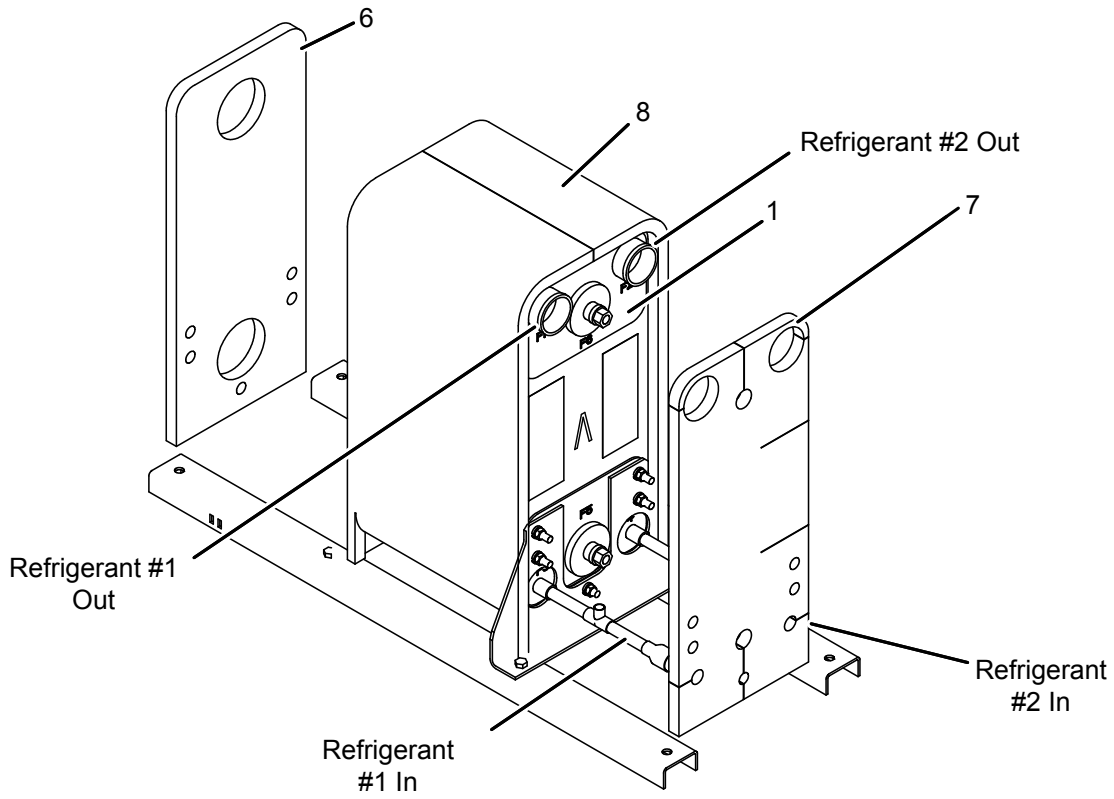

YCAL0046 SHOWN

LD15728

FIGURE 1 - SWEP HEAT EXCHANGER - STANDARD INSULATION

TABLE 2 - SWEP HEAT EXCHANGER - DOUBLE INSULATION

ITEM	DESCRIPTION	HEAT EXCHANGER		PART NUMBER*	MODELS	QUANTITY	FIGURE
		STANDARD	REMOTE				
1	Heat Exchanger	X	X	375 94523 000	YCAL0019	1	2, 3, 4
		X	X	375 94525 000	YCAL0022	1	
		X	N/A	375 94531 000	YCAL0043	1	
		N/A	X	392 01184 000	YCAL0043, YCAL0052	1	
		X	N/A	375 94533 000	YCAL0046	1	
		N/A	X	392 01186 000	YCAL0046, YCAL0056	1	
		X	N/A	375 94535 000	YCAL0052	1	
		X	N/A	375 94537 000	YCAL0056	1	
		N/A	X	392 01188 000	YCAL0066	1	
X	N/A	375 94539 000	YCAL0066	1			
5	Heater, 120 Volts, 100 Watts	X	N/A	025 40572 000	ALL	1	2, 3, 4
6	Cover Water Side	X	X	075 70428 112	YCAL0019, YCAL0022, YCAL0028, YCAL0033	2	2, 3, 4
		X	X	075 70428 141	YCAL0043, YCAL0046, YCAL0052, YCAL0056, YCAL0066	2	
7	Cover Refrigerant Side	X	X	075 70429 112	YCAL0019, YCAL0022, YCAL0028, YCAL0033	2	2, 3, 4
		X	N/A	075 70429 141	YCAL0052, YCAL0056	2	
		X	X	075 70429 141	YCAL0066	2	
8	Cover Inside, (Double Insulation)	N/A	X	075 70431 118	YCAL0019	1	2, 3, 4
		X	X	075 70431 121	YCAL0022, YCAL0028, YCAL0033	1	
		X	X	075 70431 155	YCAL0043, YCAL0052	1	
		X	X	075 70431 156	YCAL0046	1	
		X	X	075 70431 156	YCAL0056	1	
9	Cover Outside (Double Insulation)	X	X	075 70432 118	YCAL0019	1	2, 3, 4
		X	X	075 70432 122	YCAL0022	1	
		X	X	075 70432 121	YCAL0028, YCAL0033	1	
		X	X	075 70432 155	YCAL0043, YCAL0052	1	
		X	X	075 70432 156	YCAL0046, YCAL0056	1	
		X	X	075 70432 157	YCAL0066	1	

* Part numbers for heat exchangers include mounting bracket, wells and rails. On older YCAL's with Alfa Laval heat exchangers, piping modifications may be needed to install the SWEP heat exchangers. See "Figure 4 - SWEP HEAT EXCHANGER - (STANDARD AND DOUBLE INSULATION) YCAL0043 - YCAL0066" on page 11 and "Table 5 - ALFA LAVAL HEAT EXCHANGER AND RELATED COMPONENTS" on page 12 for Alfa Laval heat exchanger and related component part numbers. The TXV's are not included with the heat exchanger.

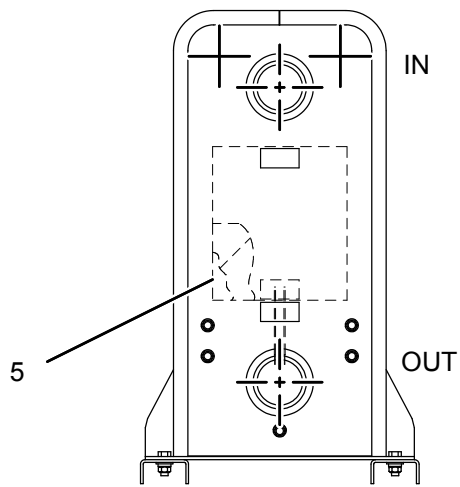
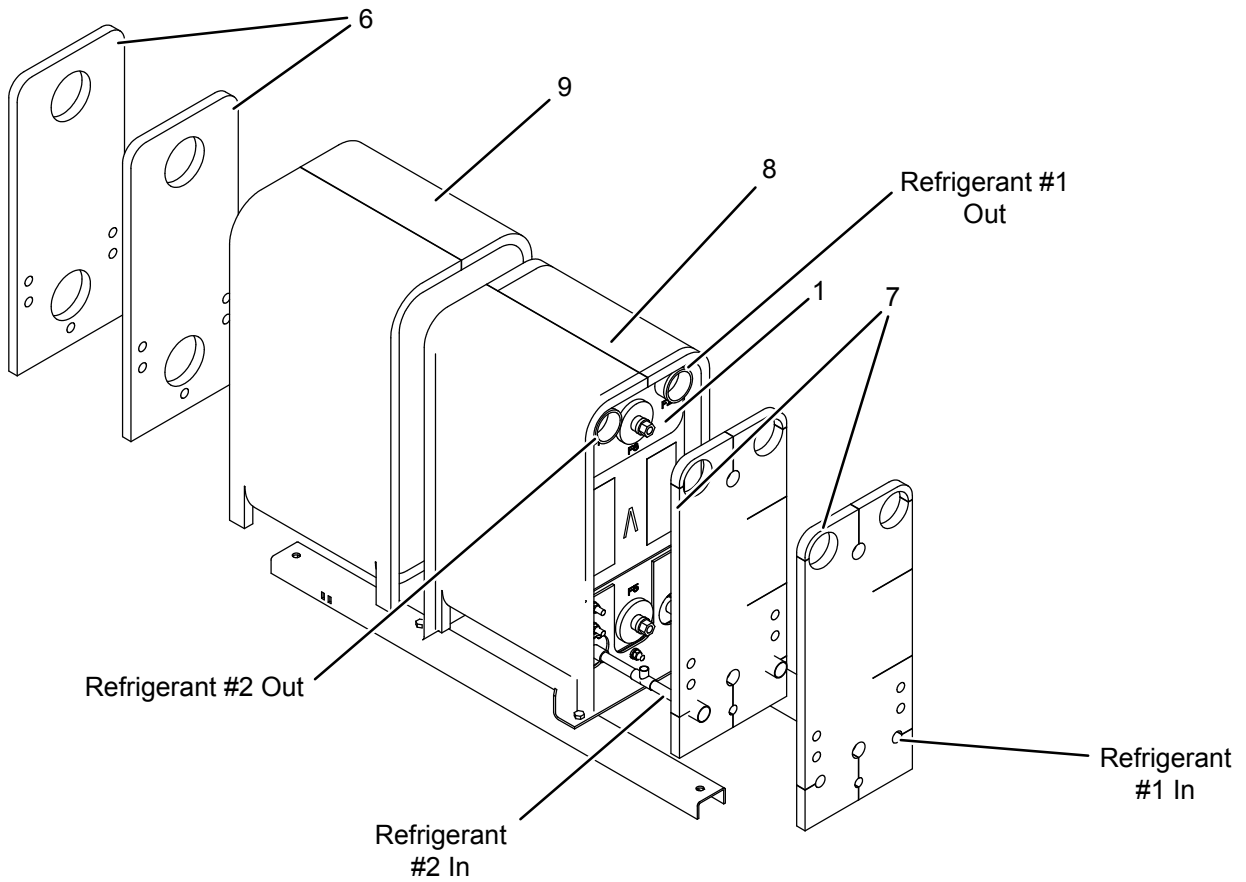

YCAL0046 SHOWN

LD15729

FIGURE 2 - SWEP HEAT EXCHANGER - DOUBLE INSULATION

TABLE 3 - SWEP HEAT EXCHANGER PARTS (STANDARD AND DOUBLE INSULATION)
 YCAL0019 - YCAL0033

ITEM	DESCRIPTION	PART NUMBER	MODELS	QUANTITY	FIGURE
2	Bracket, Heat Exchanger	075 61084 102	YCAL0019	2	3
		075 61084 103	YCAL0022, YCAL0028, YCAL0033		
3	HHCS, 0.375-16 X 1.000 Gr 5 Emp	021 19305 016	YCAL0019, YCAL0022, YCAL0028, YCAL0033	4	3
4	Washer, Plain, 3/8 ID X 7/8 OD	021 09983 000	YCAL0019, YCAL0022, YCAL0028, YCAL0033	8	3
5	Lockwasher, Spg Hel, 3/8 Reg	021 19306 000	YCAL0019, YCAL0022, YCAL0028, YCAL0033	12	3
6	Nut, Hex, 3/8 -16unc-2b	021 19307 000	YCAL0019, YCAL0022, YCAL0028, YCAL0033	8	3
7	Bracket, Heat Exchanger	075 61082 101	YCAL0019, YCAL0022, YCAL0028, YCAL0033	2	3
9	Screw, Cap Hex, 5/16 -18unc	021 16976 000	YCAL0019, YCAL0022, YCAL0028, YCAL0033	4	3
12	Well Thermo	026 32328 000	YCAL0019, YCAL0022, YCAL0028, YCAL0033	2	3
13	Washer, Plain, 7/16 ID X 1 OD	021 16140 000	YCAL0019, YCAL0022, YCAL0028, YCAL0033	4	3

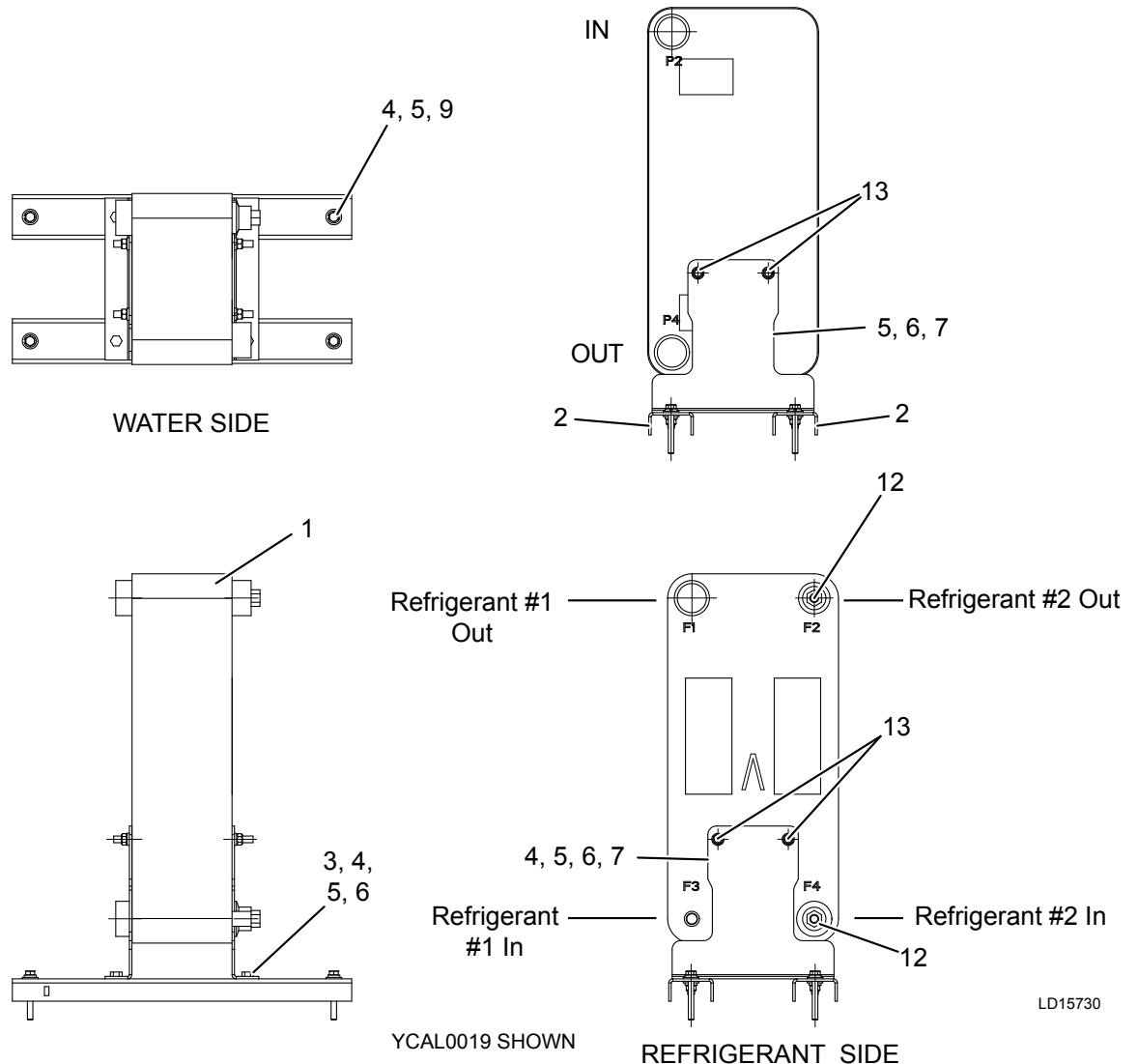
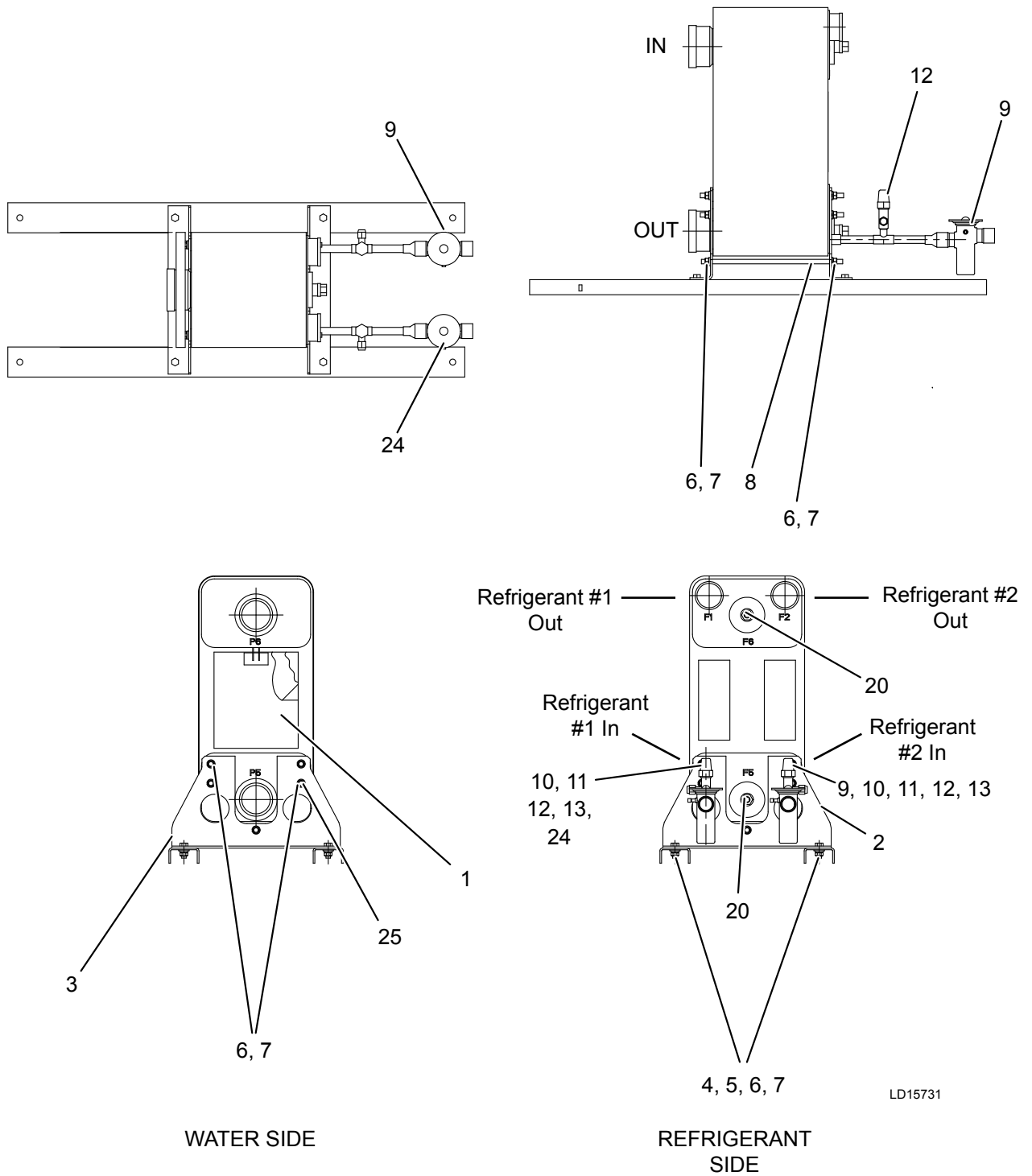

FIGURE 3 - SWEP HEAT EXCHANGER - (STANDARD AND DOUBLE INSULATION) YCAL0019 - YCAL0033

TABLE 4 - SWEP HEAT EXCHANGER AND TXV PARTS (STANDARD AND DOUBLE INSULATION)
YCAL0043 - YCAL0066

ITEM	DESCRIPTION	PART NUMBER	MODELS	QUANTITY	FIGURE
2	Bracket, Heat Exchanger	075 58280 102	YCAL0043, YCAL0052, YCAL0046, YCAL0056, YCAL0066	2	4
3	Rail, Heat Exchanger	075 61534 101	YCAL0043, YCAL0052	2	4
		075 61534 102	YCAL0046, YCAL0056		
		075 61534 103	YCAL0066		
4	HHCS, 0.375-16 X 1.000 Gr 5 Emp	021 19305 016	YCAL0043, YCAL0052, YCAL0046, YCAL0056, YCAL0066	4	4
5	Washer, Plain, 3/8 ID X 7/8 OD X	021 09983 000	YCAL0043, YCAL0052, YCAL0046, YCAL0056, YCAL0066	4	4
6	Lockwasher, Spg Hel, 3/8 Reg	021 19306 000	YCAL0043, YCAL0052, YCAL0046, YCAL0056, YCAL0066	14	4
7	Nut, Hex, 3/8 -16unc-2b	021 19307 000	YCAL0043, YCAL0052, YCAL0046, YCAL0056, YCAL0066	14	4
8	Rod, Tie, Continuous Thread, 3/8	021 31666 001	YCAL0046	1	4
		021 31666 002	YCAL0043, YCAL0052, YCAL0056		
	Rod, Tie, Continuous Thread, 3/8-16unc-2a	021 31666 006	YCAL0066		
9	Valve, TXV, Tgel 20-23	025 40900 002	YCAL0043, YCAL0046	1	4
	Valve, TXV, Tgel 40-31	025 40900 003	YCAL0052		
	Valve, TXV, Tgel 40-35	025 40900 006	YCAL0056		
	Valve, TXV, Tgel 40-46	025 40900 007	YCAL0066		
10	Pipe, Liquid	075 65211 141	YCAL0043, YCAL0046, YCAL0052, YCAL0056, YCAL0066	4	4
11	Tee, Sld C X C X C 5/8 X	023 07965 000	YCAL0043, YCAL0046, YCAL0052, YCAL0056, YCAL0066	2	4
12	Valve, Charging, Brass	022 09754 000	YCAL0043, YCAL0046, YCAL0052, YCAL0056, YCAL0066	2	4
13	Washer, Plain, 7/16 ID X 1 OD X	021 16140 000	YCAL0019, YCAL0022, YCAL0028, YCAL0033	4	3
13	Red Sld Ftg X C 1-1/8 X	023 09849 000	YCAL0043, YCAL0046, YCAL0052, YCAL0056, YCAL0066	2	4
20	Well Thermo	026 32328 000	YCAL0043, YCAL0046, YCAL0056, YCAL0052, YCAL0066	2	4
24	Valve, TXV, Tgel 20-23	025 40900 002	YCAL0043, YCAL0046	1	4
	Valve, TXV, Tgel 40-31	025 40900 003	YCAL0052		
	Valve, TXV, Tgel 40-35	025 40900 006	YCAL0056, YCAL0066		
25	Washer, Plain, 7/16 ID X 1 OD X	021 16140 000	YCAL0043, YCAL0046, YCAL0056, YCAL0052, YCAL0066	8	4



LD15731

YCAL0043 SHOWN

FIGURE 4 - SWEP HEAT EXCHANGER - (STANDARD AND DOUBLE INSULATION) YCAL0043 - YCAL0066

TABLE 5 - ALFA LAVAL HEAT EXCHANGER AND RELATED COMPONENTS

ITEM	QUANTITY	DESCRIPTION	DWP	UNIT MODEL YCAL0019 375-61095-001	UNIT MODEL YCAL0022 375-64147-001	FIGURE
1	1	Heat Exchanger, less Heater & Insulation	ALL	375-61094-002	375-61094-003	5
2	-	Insulation (3/4"x49"x65")	ALL	010-05997-000	010-05997-000	
	-	Insulation (1 1/2"x49"x65")		010-05998-000	010-05998-000	
6	1	Heater, Cooler 100 Watt	ALL	025-40572-000	025-40572-000	
9	1	Valve, Thermal Expansion	ALL	025-40900-001	025-40900-001	
12	1	Valve, Charging	ALL	022-09754-000	022-09754-000	
16	1	Valve, Relief	ALL	022-10686-001	022-10686-001	
17	1	Tube (Use w/ Item 16)	ALL	375-37977-000	375-37977-000	
19	1	Valve, Access (Suction)	ALL	022-00009-000	022-00009-000	
20	1	Well, Thermo	ALL	026-32328-000	026-32328-000	

ITEM	QUANTITY	DESCRIPTION	DWP	UNIT MODEL YCAL0028 375-64145-001	UNIT MODEL YCAL0033 375-61087-001	FIGURE
1	1	Heat Exchanger, less Heater & Insulation	ALL	375-61083-004	375-61083-005	5
2	-	Insulation (3/4"x49"x65")	ALL	010-05997-000	010-05997-000	
	-	Insulation (1 1/2"x49"x65")		010-05998-000	010-05998-000	
6	1	Heater, Cooler 100 Watt	ALL	025-40572-000	025-40572-000	
9	1	Valve, Thermal Expansion	ALL	025-40900-002	025-40900-003	
12	2	Valve, Charging	ALL	022-09754-000	022-09754-000	
16	1	Valve, Relief	ALL	022-10686-001	022-10686-001	
17	1	Tube (Use w/ Item 16)	ALL	375-37977-000	375-37977-000	
19	1	Valve, Access (Suction)	ALL	022-00009-000	022-00009-000	
20	1	Well, Thermo	ALL	026-32328-000	026-32328-000	

ITEM	QUANTITY	DESCRIPTION	DWP	UNIT MODEL YCAL0043 375-66837-001	FIGURE
1	1	Heat Exchanger, less Heater & Insulation	ALL	375-59427-005	5
2	-	Insulation (3/4"x49"x65")	ALL	010-05997-000	
	-	Insulation (1 1/2"x49"x65")		010-05998-000	
6	1	Heater, Cooler 100 Watt	ALL	025-40272-000	
9	1	Valve, Thermal Expansion	ALL	025-40900-001	
12	2	Valve, Charging	ALL	022-09754-000	
16	1	Valve, Relief	ALL	022-10686-001	
17	1	Tube (Use w/ Item 16)	ALL	375-37977-000	
19	1	Valve, Access (Suction)	ALL	022-00009-000	
20	1	Well, Thermo	ALL	026-32328-000	

TABLE 5 - ALFA LAVAL HEAT EXCHANGER AND RELATED COMPONENTS (CONT'D)

ITEM	QUANTITY	DESCRIPTION	DWP	UNIT MODEL YCAL0046 375-67242-001	UNIT MODEL YCAL0052 375-82814-001	FIGURE
1	1	Heat Exchanger, less Heater& Insulation	ALL	375-59421-005	375-59520-005	5
2	-	Insulation (3/4"x49"x65")	ALL	010-05997-000	010-05997-000	
	-	Insulation (1 1/2"x49"x65")		010-05998-000	010-05998-000	
6	1	Heater, Cooler 100 Watt	ALL	025-40272-000	025-40272-000	
9	1	Valve, Thermal Expansion	Sys 1	025-40900-001	025-40900-003	
	1		Sys 2	025-40900-002		
12	2	Valve, Charging	ALL	022-09754-000	022-09754-000	
16	2	Valve, Relief	ALL	022-10686-001	022-10686-001	
17	2	Tube (Use w/ Item 16)	ALL	375-37977-000	375-37977-000	
19	2	Valve, Access (Suction)	ALL	022-00009-000	022-00009-000	
20	2	Well, Thermo	ALL	026-32328-000	026-32328-000	

ITEM	QUANTITY	DESCRIPTION	DWP	UNIT MODEL YCAL0056 375-82813-001	UNIT MODEL YCAL0066 375-66836-001	FIGURE
1	1	Heat Exchanger, less Heater and Insulation	ALL	375-58505-006	375-58489-006	5
2	-	Insulation (3/4"x49"x65")	ALL	010-05997-000	010-05997-000	
	-	Insulation (1 1/2"x49"x65")		010-05998-000	010-05998-000	
6	1	Heater, Cooler 100 Watt	ALL	025-40272-000	025-40272-000	
9	1	Valve, Thermal Expansion	Sys 1	025-40900-006	025-40900-007	
	1		Sys 2		025-40900-006	
12	2	Valve, Charging	ALL	022-09754-000	022-09754-000	
16	2	Valve, Relief	ALL	022-10686-001	022-10686-001	
17	2	Tube (Use w/ Item 16)	ALL	375-37977-000	375-37977-000	
19	2	Valve, Access (Suction)	ALL	022-00009-000	022-00009-000	
20	2	Well, Thermo	ALL	026-32328-000	026-32328-000	

FLOW SWITCHES:

Standard 150 psig DWP cooler - 024-26116-000
Optional 300 psig DWP cooler - 024-12144-000

Service Note: Pin Location 38 in Model Number will be
"X" for 150 psig cooler.
"3" for 300 psig cooler.

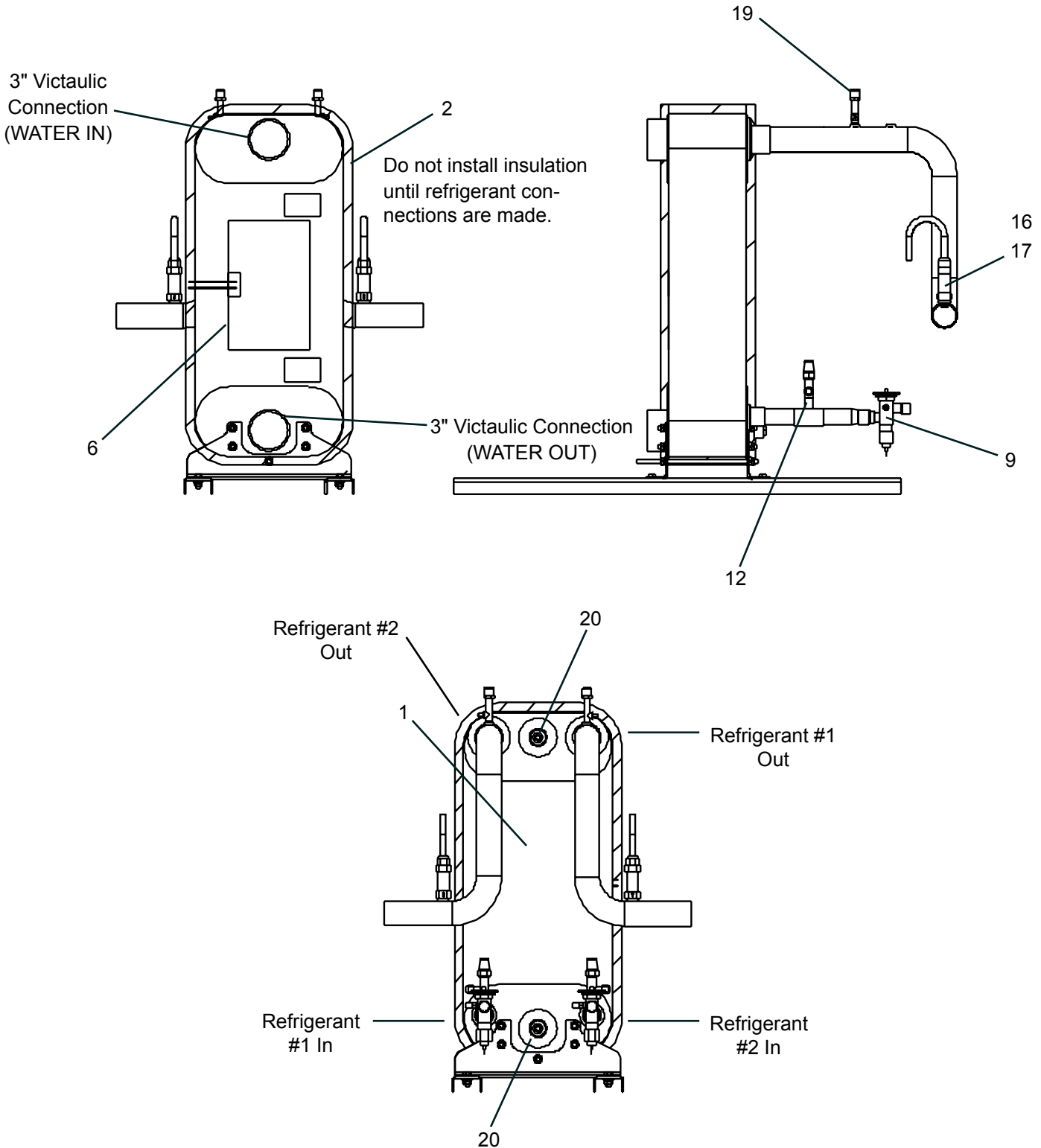

59428-1B

FIGURE 5 - ALFA LAVAL HEAT EXCHANGER COMPONENTS

SECTION 2 - CONDENSER COIL COMPONENTS

TABLE 6 - CONDENSER COIL COMPONENTS

ITEM	DESCRIPTION	QUANTITY	YCAL0019	YCAL0022	YCAL0028 and YCAL0033	FIGURE
ALUMINUM FIN COILS						
1	Coil Module*	1	375-58294-103	375-58294-203	375-58294-303	6
2		1	375-58294-104	375-58294-204	375-58294-304	
COPPER COILS						
1	Coil Module*	1	375-58294-113	375-58294-213	375-58294-313	6
2		1	375-58294-114	375-58294-214	375-58294-314	
BLACK FIN COILS						
1	Coil Module*	1	375-58294-123	375-58294-223	375-58294-323	6
2		1	375-58294-124	375-58294-224	375-58294-324	
PHENOLIC COILS						
1	Coil Module*	1	375-58294-133	375-58294-233	375-58294-333	6
2		1	375-58294-134	375-58294-234	375-58294-334	

*Note: Coil Module includes coil and headers.

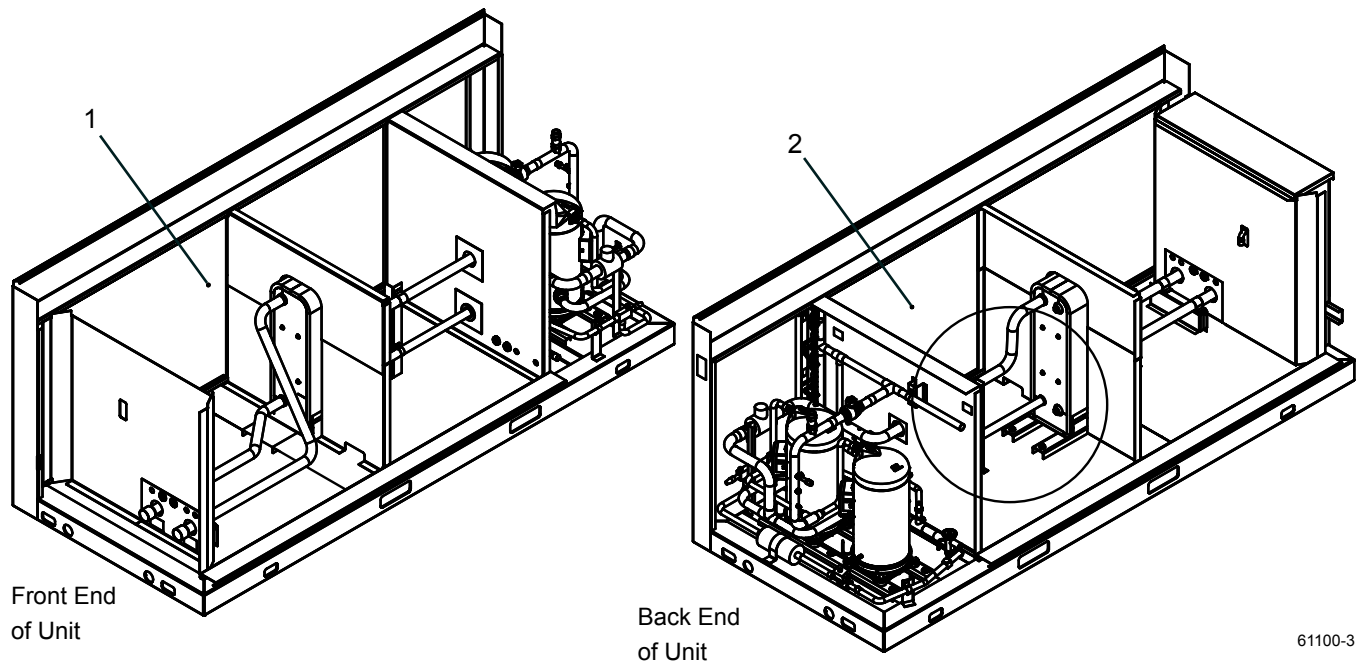

*Note: Single Circuit Model Shown.

FIGURE 6 - CONDENSER COIL LAYOUT

TABLE 7 - CONDENSER COIL COMPONENTS

ITEM	DESCRIPTION	QUANTITY	YCAL0043 and YCAL0046	YCAL0052 and YCAL0056	YCAL0066	FIGURE
ALUMINUM FIN COILS						
1	Coil Module*	1	375-58294-202	375-58294-401	375-58294-501	7
24		1	375-58294-201	375-58294-402	375-58294-502	
31		1	375-58294-205	375-58294-404	375-58294-506	
32		1	375-58294-206	375-58294-403	375-58294-505	
COPPER COILS						
1	Coil Module*	1	375-58294-212	375-58294-411	375-58294-511	7
24		1	375-58294-211	375-58294-412	375-58294-512	
31		1	375-58294-215	375-58294-414	375-58294-516	
32		1	375-58294-216	375-58294-413	375-58294-515	
BLACK FIN COILS						
1	Coil Module*	1	375-58294-222	375-58294-421	375-58294-521	7
24		1	375-58294-221	375-58294-422	375-58294-522	
31		1	375-58294-225	375-58294-424	375-58294-526	
32		1	375-58294-226	375-58294-423	375-58294-525	
PHENOLIC COILS						
1	Coil Module*	1	375-58294-232	375-58294-431	375-58294-531	7
24		1	375-58294-231	375-58294-432	375-58294-532	
31		1	375-58294-235	375-58294-434	375-58294-536	
32		1	375-58294-236	375-58294-433	375-58294-535	

*Note:Coil Module includes coil and headers.

*Note: Dual Circuit Model Shown.

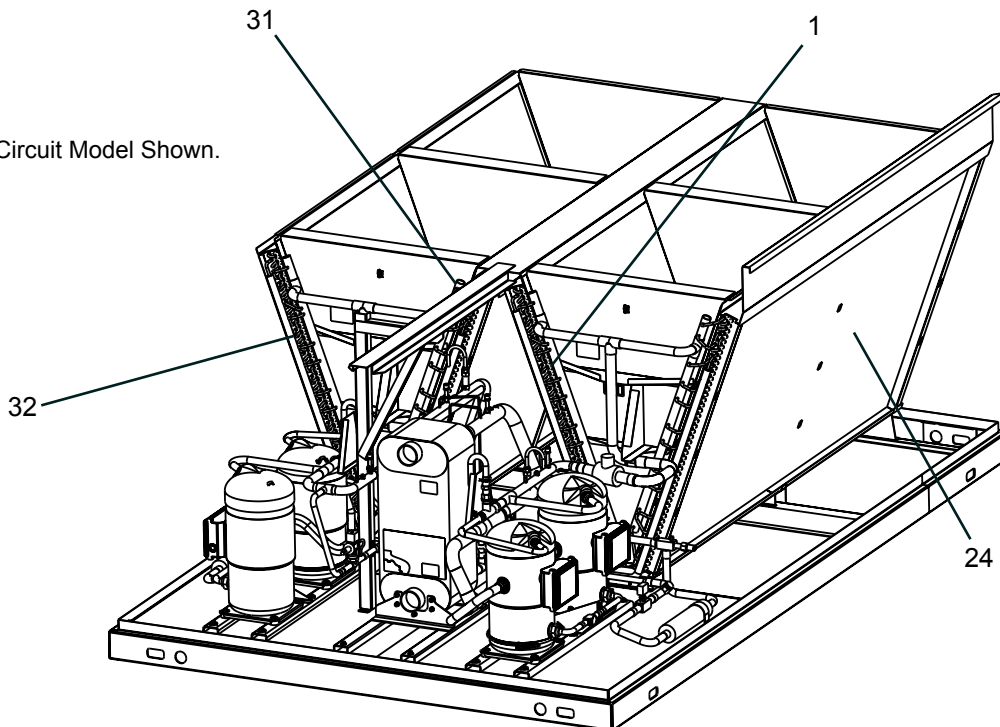

LD12477b

FIGURE 7 - CONDENSER COIL LAYOUT

SECTION 3 - FAN COMPONENTS

TABLE 8 - FAN COMPONENTS - MODELS YCAL0019 AND YCAL0022

ITEM	DESCRIPTION	VOLTAGE CODE	FAN TYPE		FIGURE
			STANDARD 7/8", 1075 RPM	ULTRA LOW NOISE 7/8", 850 RPM	
1 ^s	Motor, Fan, .5 HP (YCAL0019 & YCAL0022)	-17	024-35427-002	n/a	8
		-28	024-35427-002		
		-40	024-35427-004		
		-46	024-35427-001		
		-50	024-35427-001		
		-58	024-35427-003		
2 ^s	Blade	All	026-43008-000	n/a	8
3	Guard	All	026-37521-000		
4	Orifice	All	026-43010-000		
5	Support, Fan	All	026-43007-000	n/a	
6	Support, Ring	All	026-38369-000		
7	Hub, Square	All	026-41939-000		

^s = Recommended Spare Parts

Service Note:

Fan Hub to Shaft Joint should be sealed with protective coating - factory uses RUST VETO 344 - a solvent type, rust preventative coating.

Service Note: Pin Location 52 in Model Number will be "X" for Standard Fan, or "L" for Ultra Low Noise Fan. See "UNIT NOMENCLATURE NAMEPLATE ENGINEERING DATA" on page 4.

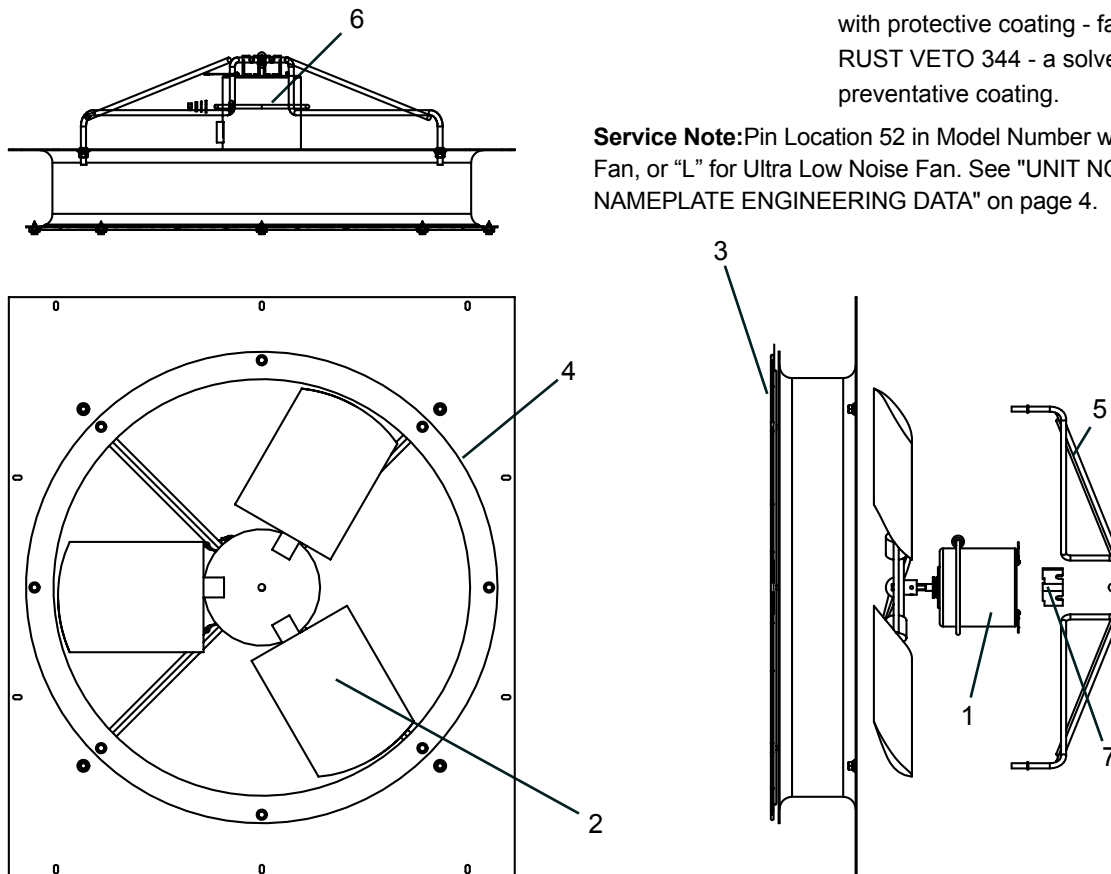

61093-0

FIGURE 8 - FAN COMPONENTS - MODELS YCAL0019 AND YCAL0022

TABLE 9 - FAN COMPONENTS - YCAL0028, 0033, 0043, 0046, 0052, 0056 & YCAL0066

ITEM	DESCRIPTION	VOLTAGE CODE	FAN TYPE		FIGURE
			STANDARD 7/8", 1150 RPM	ULTRA LOW NOISE 7/8", 850 RPM	
1 ^s	Motor, Fan, 2 HP (0028, 0033, 0043, 0046, 0052, 0056 & 0066)	-17	024-27322-103	024-34980-102	9
		-28	024-27322-106	024-34980-102	
		-40	024-27322-104	024-34980-105	
		-46	024-27322-207	024-34980-101	
		-50	024-27322-207	024-34980-101	
2 ^s	Blade (0028, 0033, 0052, 0056 & 0066)	All	026-41594-000	026-41942-000	9
	Blade (0043 & 0046)		026-41592-000	026-41593-000	
3	Guard (0028, 0033, 0052, 0056 & 0066)	All	026-46008-000		9
	Guard (0043 & 0046)		026-37521-000		
4	Orifice (0028, 0033, 0052, 0056 & 0066)	All	026-45789-000		9
	Orifice (0043 & 0046)		026-42029-000		
5	Support, Fan (0043 - 0066)	All	-----	026-45533-000	9
	Support, Fan (0028 & 0033, 0043, 0046)	All	026-41937-000	-----	
	Support, Fan (0052, 0056, 0066)	17, 28, 40, 58		-----	
	Support, Fan (0052, 0056, 0066)	46 & 50	026-41938-000	-----	
6	Support, Ring	All	026-36367-000		9
7	Spacer (.375 I.D.)	All	075-29007-000		9
8	Screw, Cap (M8x125)	All	021-18494-000		9
9	Spacer (1.406 I.D.)	All	075-40484-000		9
10	Hub, Square (0043 - 0066)	All	-----	026-41939-005	9
	Hub, Square (0028, 0033, 0052, 0056, 0066)	17, 28, 40, 58	026-41939-001	-----	
	Hub, Square (0028, 0033)	46 & 50	026-41939-002		
	Hub, Square (0052, 0056, 0066)	46 & 50	026-41939-005		
	Hub, Square (0043 & 0046)	All	026-41939-001		

^s = Recommended Spare Parts

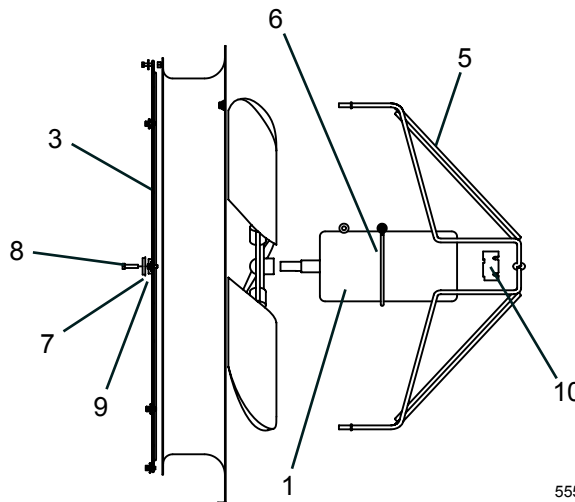
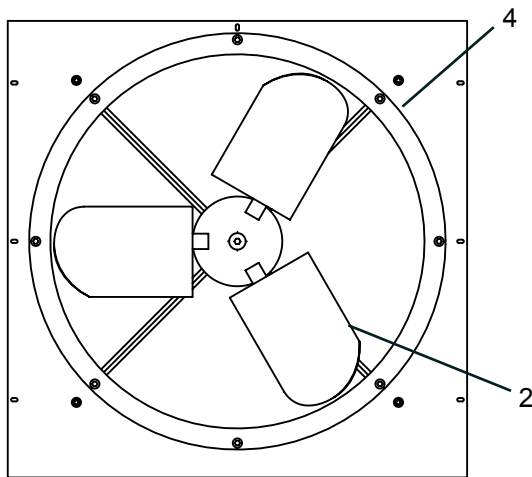

55596-000

Service Note: Pin Location 52 in Model Number will be "X" for Standard Fan, or "L" for Ultra Low Noise Fan. See "UNIT NOMENCLATURE NAMEPLATE ENGINEERING DATA" on page 4.

Service Note: Fan Hub to Shaft Joint should be sealed with protective coating - factory uses RUST VETO 344 - a solvent type, rust preventative coating.

FIGURE 9 - FAN COMPONENTS - YCAL0028, 0033, 0043, 0046, 0052, 0056 AND YCAL0066

SECTION 4 - REFRIGERANT PIPING COMPONENTS

CHILLER MODEL YCAL – STYLE 'E'

TABLE 10 - REFRIGERANT PIPING COMPONENTS

ITEM	QUANTITY	DESCRIPTION	SYSTEM	YCAL0019 and YCAL0022	YCAL0028	YCAL0033	FIGURE
1^S	1	Valve, Thermal Expansion	1	025-40900-001	025-40900-002	025-40900-003	10
2	2	Valve, Charging (Liquid Line)	1	022-09754-000	022-09754-000	022-09754-000	
3	1	Valve, Solenoid (Liquid Line)	1	025-42077-000	025-41558-000	025-41558-000	
4^S	1	Valve, Stop (Liquid Line)	1	022-11306-000	022-10022-000	022-10022-000	
5	1	Drier	1	026-35634-000	026-20145-000	026-20145-000	
6A	1	Moisture Indicator	1	026-12992-000	026-12992-000	026-12992-000	
7	1	Valve, Access (Suction)	1	022-00009-000	022-00009-000	022-00009-000	
8	1	Valve, Relief (Suction)	1	022-10686-001	022-10686-001	022-10686-001	
9	1	Tube w/ Nut (Use with Item 8)	1	375-37977-000	375-37977-000	375-37977-000	
10A	1	Valve, Ball (Suction)	1	022-08883-000	022-09752-000	022-09752-000	11
11	1	Valve, Access (Discharge)	1	022-00009-000	022-00009-000	022-00009-000	12
12A	1	Valve, Ball (Discharge)	1	022-09750-000	022-09750-000	022-09750-000	
13	2	Compressor	1	See Tables 12 and 13			
14	1	Valve, Relief (Discharge)	1	022-10682-001	022-10682-001	022-10682-001	
15	1	Inline Sight Glass	1	026-41616-000	026-41616-000	026-41616-000	13

^S = Recommended Spare Part

TABLE 10 – REFRIGERANT PIPING COMPONENTS (CONT'D)

ITEM	QUANTITY	DESCRIPTION	SYSTEM	YCAL0043	YCAL0046	YCAL0052	FIGURE
1^S	1	Valve, Thermal Expansion	Sys1	025-40900-001	025-40900-001	025-40900-003	10
	1		Sys2		025-40900-002		
2	2	Valve, Charging (Liquid Line)	Both	022-09754-000	022-09754-000	022-09754-000	
3	2	Valve, Solenoid (Liquid Line)	Both	025-42077-000	025-42077-000	025-42077-000	
4^S	2	Valve, Stop (Liquid Line)	Both	022-10022-000	022-10022-000	022-10022-000	
5	2	Dehydrator	Both	026-36510-000	026-36510-000	026-36510-000	
6A	2	Moisture Indicator, Body	Both	026-32397-000	026-32397-000	026-32397-000	
6B	2	Moisture Indicator, Sight Glass Cap	Both	026-32800-000	026-32800-000	026-32800-000	
7	2	Valve, Access (Suction)	Both	022-00009-000	022-00009-000	022-00009-000	
8	2	Valve, Relief (Suction)	Both	022-10686-001	022-10686-001	022-10686-001	
9	2	Tube w/ Nut (Use with Item 8)	Both	375-37977-000	375-37977-000	375-37977-000	
10A	1	Valve, Ball (Suction)	Sys1	022-09752-000	022-09752-000	022-09752-000	11
10B	1		Sys2				
11	2	Valve, Access (Discharge)	Both	022-00009-000	022-00009-000	022-00009-000	12
12A	1	Valve, Ball (Discharge)	Sys1	022-09750-000	022-09750-000	022-09750-000	
12B	1		Sys2				
13	4	Compressor	Both	See Tables 12 and 13			
14	2	Valve, Relief (Discharge)	Both	022-10682-001	022-10682-001	022-10682-001	
15	2	Inline Sight Glass	Both	026-41616-000	026-41616-000	026-41616-000	13

^S = Recommended Spare Part

TABLE 10 – REFRIGERANT PIPING COMPONENTS (CONT'D)

ITEM	QUANTITY	DESCRIPTION	SYSTEM	YCAL0056 375-66827-100	YCAL0066	FIGURE
1^S	1	Valve, Thermal Expansion	Sys1	025-40900-006	025-40900-007	10
	1		Sys2		025-40900-006	
2	2	Valve, Charging (Liquid Line)	Both	022-09754-000	022-09754-000	
3	2	Valve, Solenoid (Liquid Line)	Both	025-41558-000	025-41558-000	
4^S	2	Valve, Stop (Liquid Line)	Both	022-10022-000	022-10022-000	
5	2	Dehydrator	Both	026-36510-000	026-36510-000	
6A	2	Moisture Indicator, Body	Both	026-32397-000	026-32397-000	
6B	2	Moisture Indicator, Sight Glass Cap	Both	026-32800-000	026-32800-000	
7	2	Valve, Access (Suction)	Both	022-00009-000	022-00009-000	
8	2	Valve, Relief (Suction)	Both	022-10686-001	022-10686-001	
9	2	Tube w/ Nut (Use with Item 8)	Both	375-37977-000	375-37977-000	
10A	1	Valve, Ball (Suction)	Sys1	022-09752-000	022-09753-000	11
10B	1		Sys2		022-09752-000	
11	2	Valve, Access (Discharge)	Both	022-00009-000	022-00009-000	12
12A	1	Valve, Ball (Discharge)	Sys1	022-09750-000	022-11720-000	
12B	1		Sys2			
13	4	Compressor	Both	See Tables 12 and 13		
14	2	Valve, Relief (Discharge)	Both	022-10682-001	022-10682-001	
15	2	Inline Sight Glass	Both	026-41616-000	026-41616-000	13

^S = Recommended Spare Part

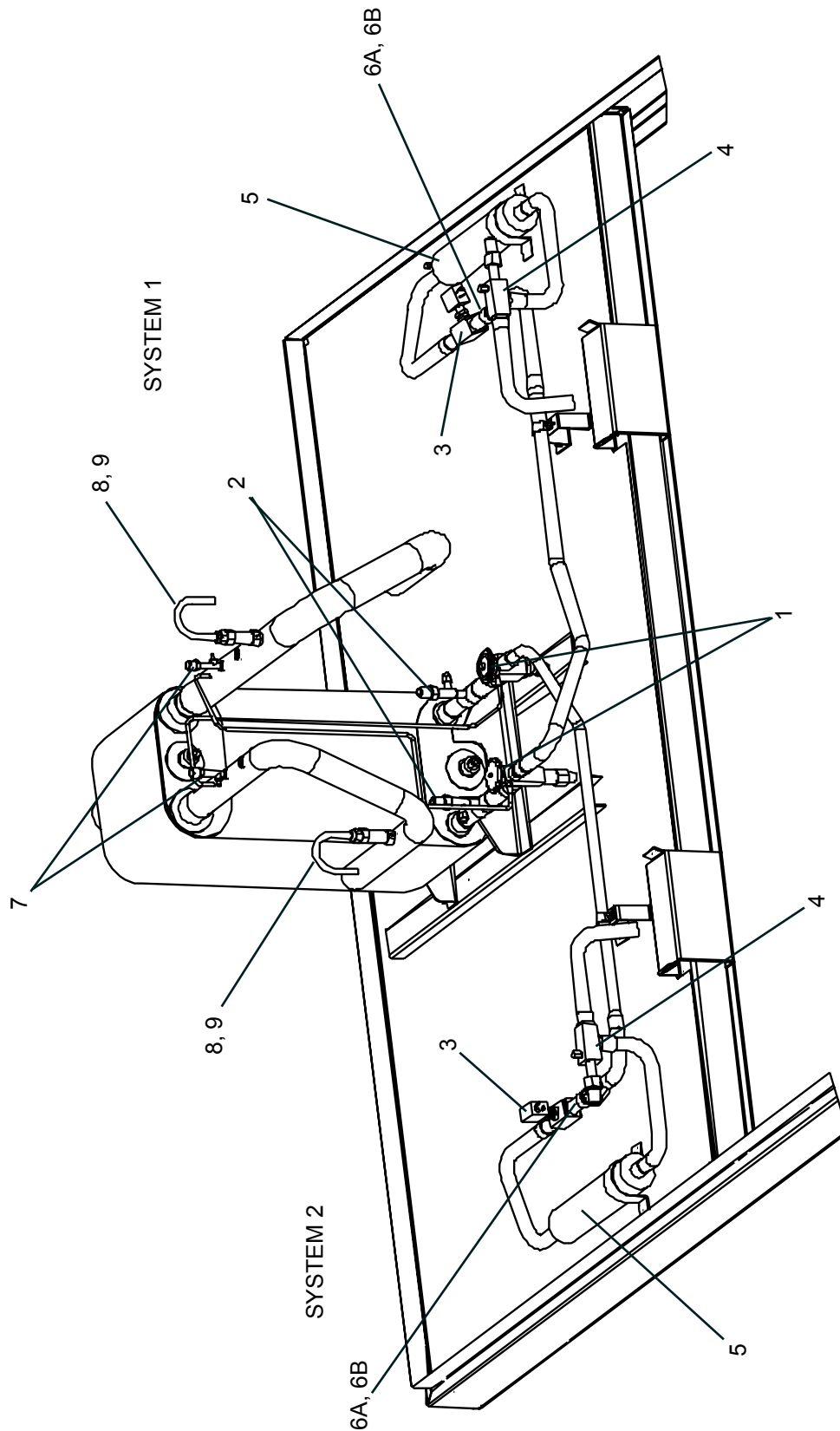

58283-1

FIGURE 10 - REFRIGERANT PIPING COMPONENTS (SUCTION AND LIQUID) - MODEL YCAL0066 SHOWN

58283-3

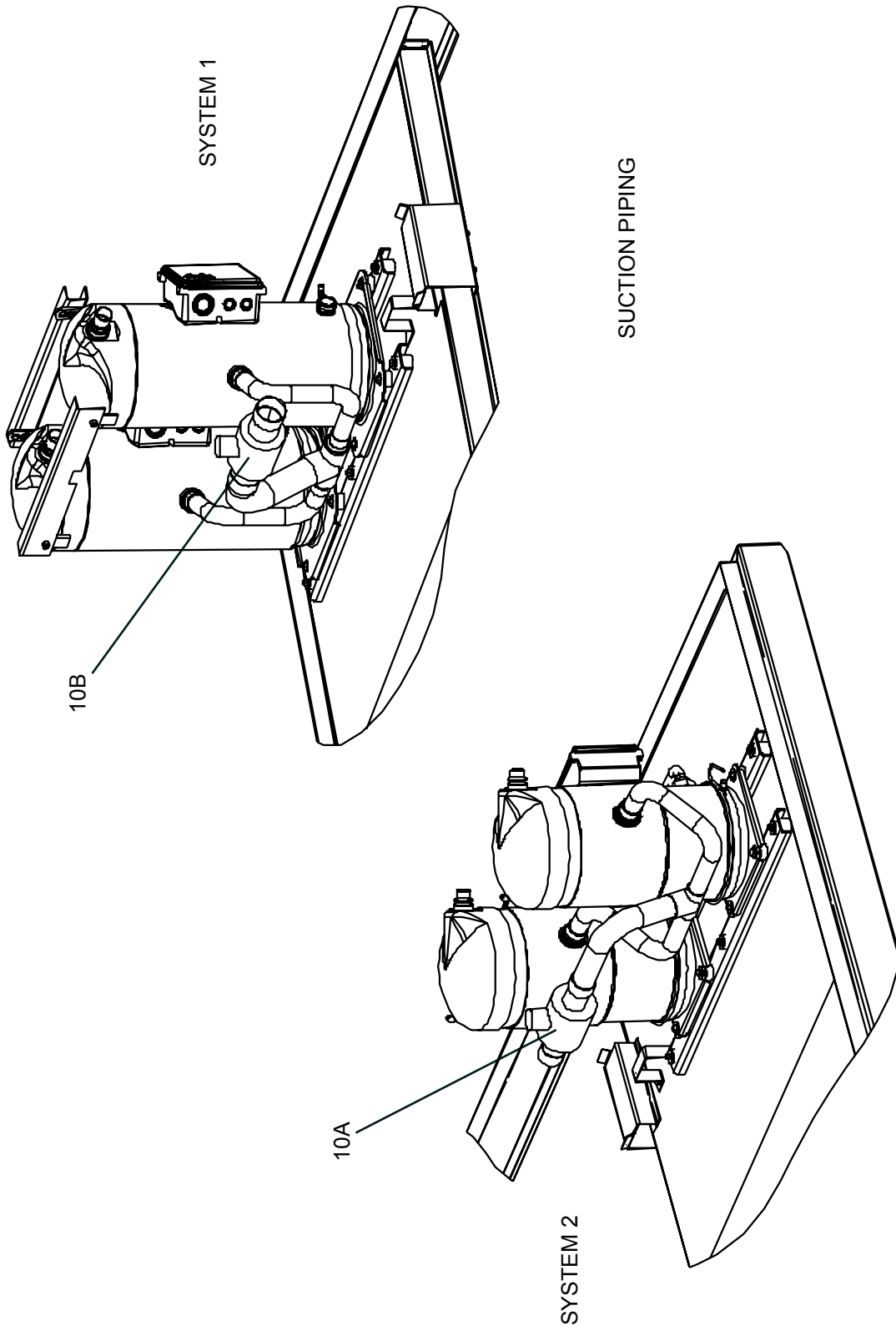

FIGURE 11 - REFRIGERANT PIPING COMPONENTS (SUCTION) - MODEL YCAL0066 SHOWN

58283-2

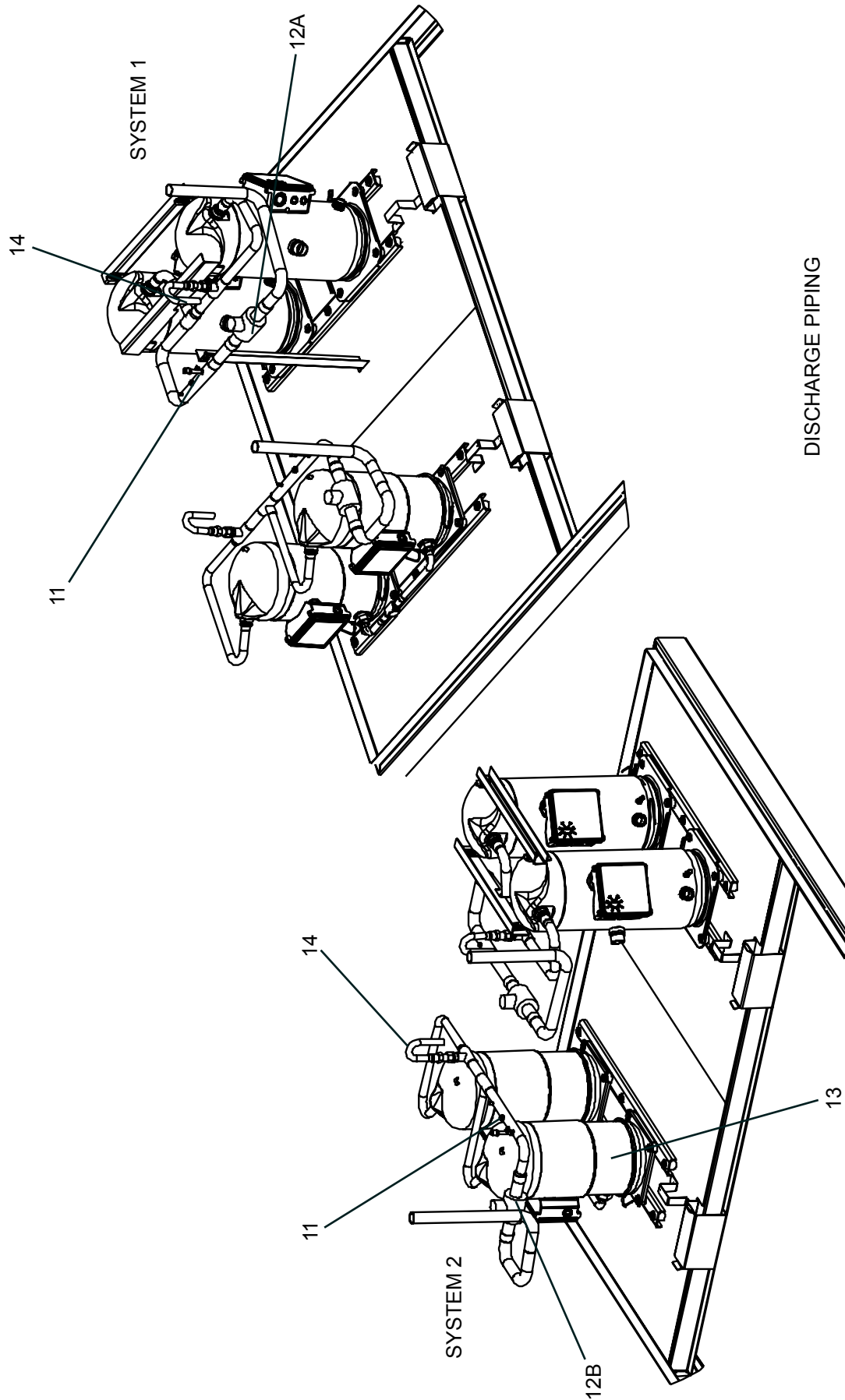

FIGURE 12 - REFRIGERANT PIPING COMPONENTS (DISCHARGE) - MODEL YCAL0066 SHOWN

56283-4

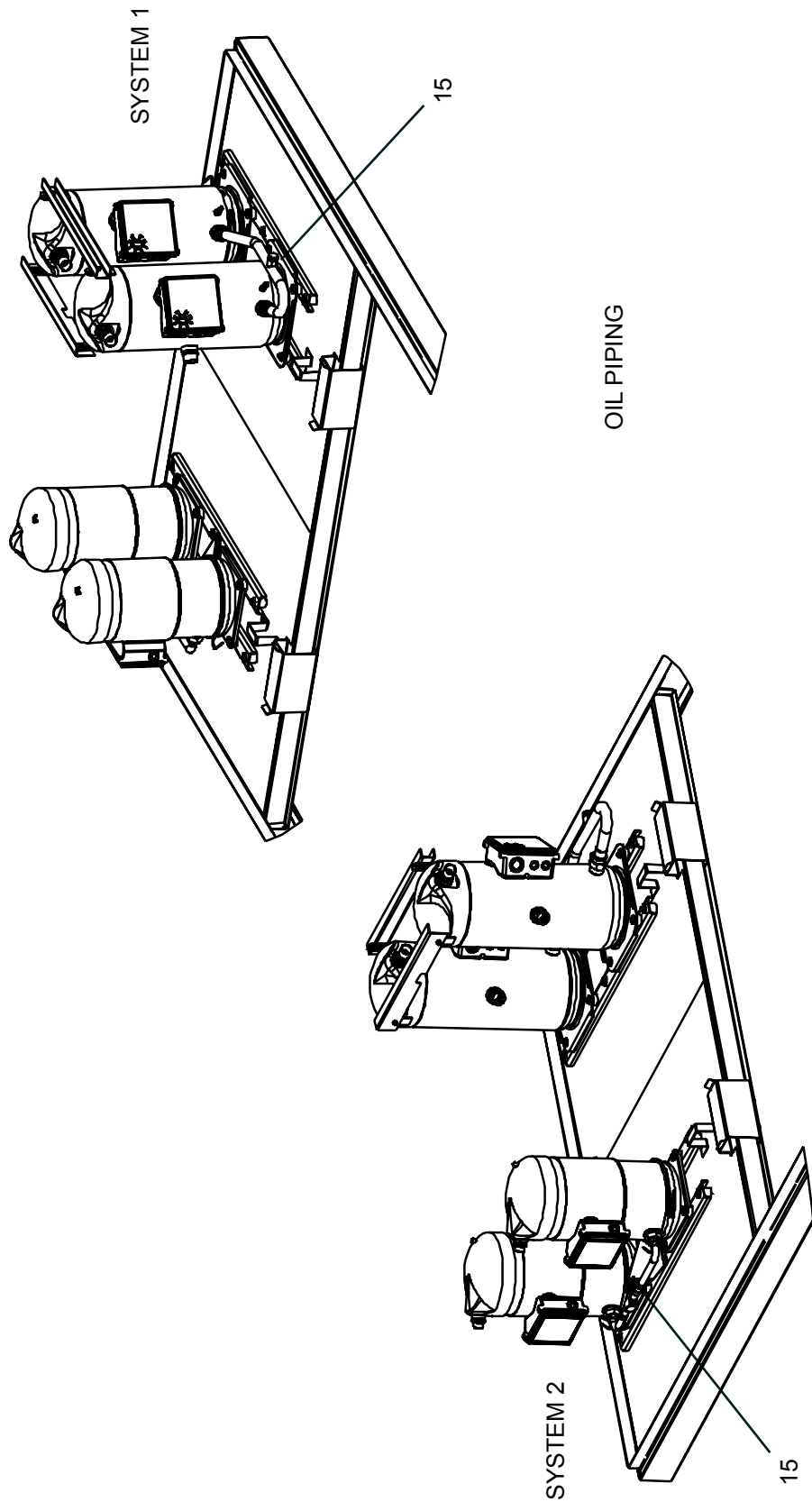

FIGURE 13 - REFRIGERANT PIPING COMPONENTS (OIL) - MODEL YCAL0066 SHOWN

THIS PAGE INTENTIONALLY LEFT BLANK

SECTION 5 - COMPRESSOR COMPONENTS

TABLE 11 - RECOMMENDED OIL TYPE

ITEM	COOLANT	DESCRIPTION	(6) 1 GALLON	5 GALLON
OIL ^S	R-410A	OIL, COMPRESSOR (TYPE 'V')	011-00948-000	011-00949-000

^S = Recommended Spare Part

TABLE 12 - R-410A COMPRESSOR PART NUMBERS

MODEL	VOLTAGE CODE	SYSTEM 1		SYSTEM 1		FIGURE
		#1 COMPRESSOR		#2 COMPRESSOR		
		PART #	MODEL #	PART #	MODEL #	
YCAL0019	-17 & -28	015-04041-101	ZP103KCE	015-04041-101	ZP103KCE	14
	-40	015-04041-102	ZP103KCE	015-04041-102	ZP103KCE	
	-46 & -50	015-04041-104	ZP103KCE	015-04041-104	ZP103KCE	
	-58	015-04041-105	ZP103KCE	015-04041-105	ZP103KCE	
YCAL0022	-17 & -28	015-04042-101	ZP120KCE	015-04042-101	ZP120KCE	
	-40	015-04042-102	ZP120KCE	015-04042-102	ZP120KCE	
	-46 & -50	015-04042-104	ZP120KCE	015-04042-104	ZP120KCE	
	-58	015-04042-105	ZP120KCE	015-04042-105	ZP120KCE	
YCAL0028	-17 & -28	015-04166-101	ZP182KCE	015-04055-101	ZP154KCE	
	-40	015-04166-102	ZP182KCE	015-04055-102	ZP154KCE	
	-46 & -50	015-04166-104	ZP182KCE	015-04055-104	ZP154KCE	
	-58	015-04166-105	ZP182KCE	015-04055-105	ZP154KCE	
YCAL0033 (New P/N)*	-17 & -28	015-04166-101	ZP182KCE*	015-04166-101	ZP182KCE*	
	-40	015-04166-102	ZP182KCE*	015-04166-102	ZP182KCE*	
	-46 & -50	015-04166-104	ZP182KCE*	015-04166-104	ZP182KCE*	
	-58	015-04166-105	ZP182KCE*	015-04166-105	ZP182KCE*	
YCAL0033 (Old P/N)*	-17 & -28	015-04045-101	ZP180KCE*	015-04045-101	ZP180KCE*	
	-40	015-04045-102	ZP180KCE*	015-04045-102	ZP180KCE*	
	-46 & -50	015-04045-104	ZP180KCE*	015-04045-104	ZP180KCE*	
	-58	015-04045-105	ZP180KCE*	015-04045-105	ZP180KCE*	
YCAL0043	-17 & -28	015-04042-101	ZP120KCE	015-04042-101	ZP120KCE	
	-40	015-04042-102	ZP120KCE	015-04042-102	ZP120KCE	
	-46 & -50	015-04042-104	ZP120KCE	015-04042-104	ZP120KCE	
	-58	015-04042-105	ZP120KCE	015-04042-105	ZP120KCE	
YCAL0046	-17 & -28	015-04043-101	ZP137KCE	015-04043-101	ZP137KCE	
	-40	015-04043-102	ZP137KCE	015-04043-102	ZP137KCE	
	-46 & -50	015-04043-104	ZP137KCE	015-04043-104	ZP137KCE	
	-58	015-04043-105	ZP137KCE	015-04043-105	ZP137KCE	

* Compressors are not interchangeable. The correct compressor must be used; substitutions are not possible.

Select the proper compressor Part Number based on the compressor model on the unit.

TABLE 12 - R-410A COMPRESSOR PART NUMBERS (CONT'D)

MODEL	VOLTAGE CODE	SYSTEM 2 #4 COMPRESSOR		SYSTEM 2 #5 COMPRESSOR		FIGURE
		PART #	MODEL #	PART #	MODEL #	
YCAL0019	-17 & -28	n/a	n/a	n/a	n/a	14
	-40	n/a	n/a	n/a	n/a	
	-46 & -50	n/a	n/a	n/a	n/a	
	-58	n/a	n/a	n/a	n/a	
YCAL0022	-17 & -28	n/a	n/a	n/a	n/a	
	-40	n/a	n/a	n/a	n/a	
	-46 & -50	n/a	n/a	n/a	n/a	
	-58	n/a	n/a	n/a	n/a	
YCAL0028	-17 & -28	n/a	n/a	n/a	n/a	
	-40	n/a	n/a	n/a	n/a	
	-46 & -50	n/a	n/a	n/a	n/a	
	-58	n/a	n/a	n/a	n/a	
YCAL0033	-17 & -28	n/a	n/a	n/a	n/a	
	-40	n/a	n/a	n/a	n/a	
	-46 & -50	n/a	n/a	n/a	n/a	
	-58	n/a	n/a	n/a	n/a	
YCAL0043	-17 & -28	015-04042-101	ZP120KCE	015-04042-101	ZP120KCE	
	-40	015-04042-102	ZP120KCE	015-04042-102	ZP120KCE	
	-46 & -50	015-04042-104	ZP120KCE	015-04042-104	ZP120KCE	
	-58	015-04042-105	ZP120KCE	015-04042-105	ZP120KCE	
YCAL0046	-17 & -28	015-04042-101	ZP120KCE	015-04042-101	ZP120KCE	
	-40	015-04042-102	ZP120KCE	015-04042-102	ZP120KCE	
	-46 & -50	015-04042-104	ZP120KCE	015-04042-104	ZP120KCE	
	-58	015-04042-105	ZP120KCE	015-04042-105	ZP120KCE	

MODEL	VOLTAGE CODE	SYSTEM 1 #1 COMPRESSOR		SYSTEM 1 #2 COMPRESSOR		FIGURE
		PART #	MODEL #	PART #	MODEL #	
YCAL0052	-17 & -28	015-04055-101	ZP154KCE	015-04055-101	ZP154KCE	14
	-40	015-04055-102	ZP154KCE	015-04055-102	ZP154KCE	
	-46 & -50	015-04055-104	ZP154KCE	015-04055-104	ZP154KCE	
	-58	015-04055-105	ZP154KCE	015-04055-105	ZP154KCE	
YCAL0056	-17 & -28	015-04166-101	ZP182KCE	015-04166-101	ZP182KCE	
	-40	015-04166-102	ZP182KCE	015-04166-102	ZP182KCE	
	-46 & -50	015-04166-104	ZP182KCE	015-04166-104	ZP182KCE	
	-58	015-04166-105	ZP182KCE	015-04166-105	ZP182KCE	
YCAL0066	-17 & -28	015-04044-101	ZP235KCE	015-04044-101	ZP235KCE	
	-40	015-04044-102	ZP235KCE	015-04044-102	ZP235KCE	
	-46 & -50	015-04044-104	ZP235KCE	015-04044-104	ZP235KCE	
	-58	015-04044-105	ZP235KCE	015-04044-105	ZP235KCE	

TABLE 12 - R-410A COMPRESSOR PART NUMBERS (CONT'D)

MODEL	VOLTAGE CODE	SYSTEM 2		SYSTEM 2		FIGURE
		#4 COMPRESSOR		#5 COMPRESSOR		
		PART #	MODEL #	PART #	MODEL #	
YCAL0052	-17 & -28	015-04055-101	ZP154KCE	015-04055-101	ZP154KCE	14
	-40	015-04055-102	ZP154KCE	015-04055-102	ZP154KCE	
	-46 & -50	015-04055-104	ZP154KCE	015-04055-104	ZP154KCE	
	-58	015-04055-105	ZP154KCE	015-04055-105	ZP154KCE	
YCAL0056	-17 & -28	015-04166-101	ZP182KCE	015-04166-101	ZP182KCE	
	-40	015-04166-102	ZP182KCE	015-04166-102	ZP182KCE	
	-46 & -50	015-04166-104	ZP182KCE	015-04166-104	ZP182KCE	
	-58	015-04166-105	ZP182KCE	015-04166-105	ZP182KCE	
YCAL0066 (New P/N)*	-17 & -28	015-04166-101	ZP182KCE	015-04166-101	ZP182KCE	
	-40	015-04166-102	ZP182KCE	015-04166-102	ZP182KCE	
	-46 & -50	015-04166-104	ZP182KCE	015-04166-104	ZP182KCE	
	-58	015-04166-105	ZP182KCE	015-04166-105	ZP182KCE	
YCAL0066 (Old P/N)*	-17 & -28	015-04045-101	ZP180KCE	015-04045-101	ZP180KCE	
	-40	015-04045-102	ZP180KCE	015-04045-102	ZP180KCE	
	-46 & -50	015-04045-104	ZP180KCE	015-04045-104	ZP180KCE	
	-58	015-04045-105	ZP180KCE	015-04045-105	ZP180KCE	

* Compressors are not interchangeable. The correct compressor must be used; substitutions are not possible.

Select the proper compressor Part Number based on the compressor model on the unit.

TABLE 13 - COMPRESSOR HEATER AND COMPRESSOR SOUND BLANKET PART NUMBERS

COMPRESSOR PART NUMBER	HEATER PART NUMBER	QUANTITY PER COMPRESSOR	SOUND BLANKET PART NUMBER	QUANTITY PER COMPRESSOR	FIGURE
015-04041-xxx	025-40351-000	1	010-06507-005	1	14
015-04042-xxx	025-40351-000	1	010-06507-005	1	
015-04043-xxx	025-40351-000	1	010-06507-005	1	
015-04044-xxx	025-37852-000	1	010-06507-001	1	
015-04045-xxx	025-37888-000	1	010-06507-002	1	
015-04055-xxx	025-40351-000	1	010-06507-007	1	
015-04166-xxx	025-37888-000	1	010-06507-007	1	

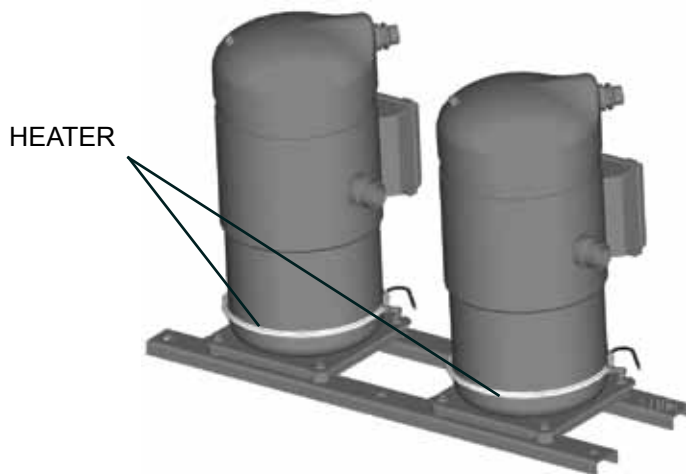
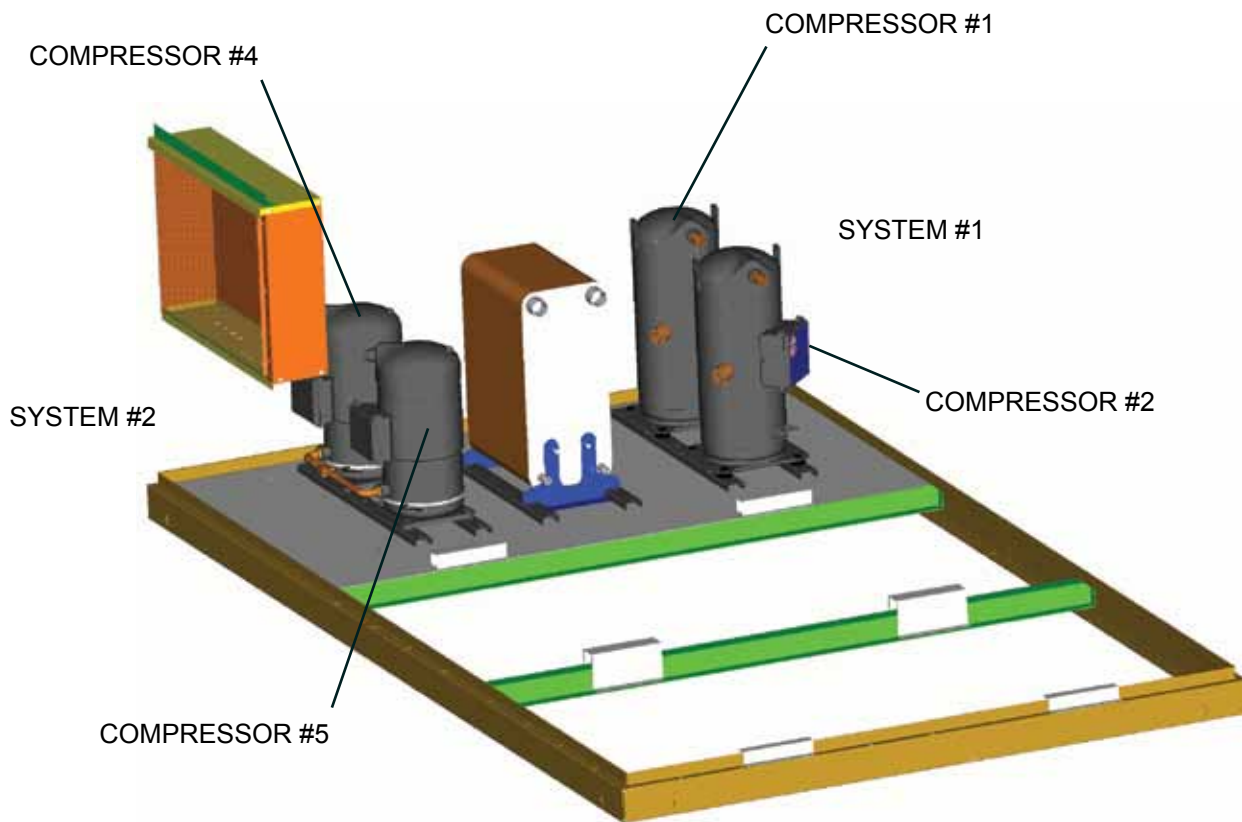

55692-000-A

FIGURE 14 - COMPRESSOR - TYPICAL LAYOUT

SECTION 6 - CONTROL PANEL AND POWER PANEL CONFIGURATIONS

Power panels and option panels are offered in several different configurations using three (3) major components:

1. Terminal Blocks
2. Circuit Breakers
3. Non-Fused Disconnect Switches

The most basic chiller power wiring configuration uses Terminal Blocks in the power panels, and an options panel with no power wire termination hardware. The model pin number locations 16 and 17 would be as shown in the table below to reflect this basic combination. Identify model pin number locations 16 and 17 to identify the chiller power wiring connections and hardware listed below. See "UNIT NOMENCLATURE NAMEPLATE ENGINEERING DATA" on page 4.

TABLE 14 - OPTION PANEL AND POWER PANEL CONFIGURATIONS

PIN 16 & 17 LETTER CODE IDENTIFIERS		CONFIGURATIONS
S	X	Single Point Supply Terminal Block
S	D	Single Point Supply Non-Fused Disconnect Switch
B	X	Single Point Supply Circuit Breaker

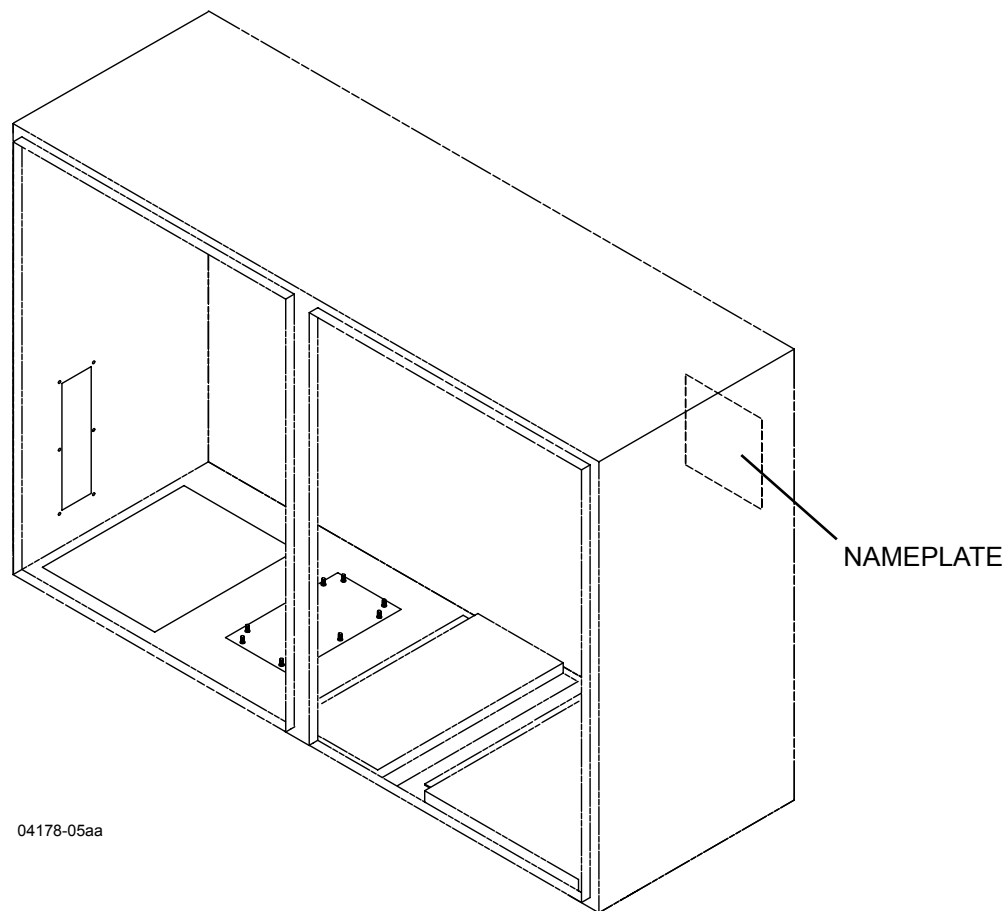

FIGURE 15 - CONTROL AND POWER PANEL IDENTIFIER LOCATION

THIS PAGE INTENTIONALLY LEFT BLANK

SECTION 7 - CONTROL PANEL AND POWER PANEL COMPONENTS

To identify replacement part numbers, select “Panel Identifier Number” from the table below or from the panel nameplate shown on Figure 15 on page 31,

then refer to the “Control and Power Panel Components” information (Table 16 on page 34; see also Figure 16 on page 49 and Figure 17 on page 50).

TABLE 15 - CONTROL PANEL AND POWER PANEL IDENTIFIERS

MODEL	VOLTAGE CODE	SINGLE POINT TERMINAL BLOCK (SX)	SINGLE POINT NON-FUSED DISCONNECT SWITCH (SD)	SINGLE POINT CIRCUIT BREAKER (BX)
YCAL0019	17 & 28	371-05161-101	371-05161-201	371-05161-301
	40 & 46	371-05161-102	371-05161-202	371-05161-302
	50 & 58	371-05161-102	371-05161-202	371-05161-302
YCAL0022	17 & 28	371-05161-101	371-05161-201	371-05161-301
	40 & 46	371-05161-102	371-05161-202	371-05161-302
	50 & 58	371-05161-102	371-05161-202	371-05161-302
YCAL0028	17 & 28	371-05162-101	371-05162-201	371-05162-301
	40 & 46	371-05162-102	371-05162-202	371-05162-302
	50 & 58	371-05162-102	371-05162-202	371-05162-302
YCAL0033	17 & 28	371-05162-101	371-05162-201	371-05162-301
	40 & 46	371-05162-102	371-05162-202	371-05162-302
	50 & 58	371-05162-102	371-05162-202	371-05162-302
YCAL0043	17 & 28	371-05163-101	371-05163-201	371-05163-301
	40 & 46	371-05163-102	371-05163-202	371-05163-302
	50 & 58	371-05163-102	371-05163-202	371-05163-302
YCAL0046	17 & 28	371-05163-101	371-05163-201	371-05163-301
	40 & 46	371-05163-102	371-05163-202	371-05163-302
	50 & 58	371-05163-102	371-05163-202	371-05163-302
YCAL0052	17, 28 & 40	371-05163-103	371-05163-203	371-05163-303
	46, 50 & 58	371-05163-102	371-05163-202	371-05163-302
YCAL0056	17, 28 & 40	371-05163-103	371-05163-203	371-05163-303
	46, 50 & 58	371-05163-102	371-05163-202	371-05163-302
YCAL0066	17 & 28	371-05163-103	371-05163-203	371-05163-303
	40 & 46	371-05163-104	371-05163-204	371-05163-304
	50 & 58	371-05163-104	371-05163-204	371-05163-304

TABLE 16 - CONTROL AND POWER PANEL COMPONENTS

ITEM	QUANTITY	DESCRIPTION	YCAL0019-17 & YCAL0019-28 YCAL0022-17 & YCAL0022-28			FIGURE
			371-05161-101SX**	371-05161-201SD**	371-05161-301BX**	
2	1	Control Transformer	025-27911-000	025-27911-000	025-27911-000	16
2A	1	Single Point Terminal Block	025-39423-000	N/A	N/A	
	1	Single Point Circuit Breaker	N/A	N/A	025-34419-000	
	1	Single Point NF Disconnect Switch	N/A	024-31871-000	N/A	
2B	1	Lugs	N/A	025-34480-000	025-34418-000	
2C	1	Ground Lug	025-34455-000	025-34089-000	025-34089-000	
3A	1	Control Board, IPU 2	031-02550-101*	031-02550-101*	031-02550-101*	
3B	1	Flash Card	031-02755-001	031-02755-001	031-02755-001	
4A	4	Compressor Contactor	024-35467-000	024-35467-000	024-35467-000	
4B	4	Surge Suppressor	031-00808-000	031-00808-000	031-00808-000	
4D	4	Auxiliary Contact	024-35493-000	N/A	N/A	
5	2	Control Relay	024-35526-000	024-35526-000	024-35526-000	
5A	2	Surge Suppressor	031-00808-000	031-00808-000	031-00808-000	
6B	1	Display	031-02749-000	031-02749-000	031-02749-000	17
6D	1	Switch	024-25517-000	024-25517-000	024-25517-000	
6F	1	Ribbon Cable	031-02108-000	031-02108-000	031-02108-000	
7C	4	Fan Contactor	024-35441-000	024-35441-000	024-35441-000	16
7D	4	Surge Suppressor	031-00808-000	031-00808-000	031-00808-000	
7E	2	Fuse Block	025-37864-000	025-37864-000	025-37864-000	
7F	6	Fuse	025-34139-000	025-34139-000	025-34139-000	
10	1	Ground Bar	025-35685-000	025-35685-000	025-35685-000	
11	1	Fuse Block	025-37862-000	025-37862-000	025-37862-000	
11A	1	Fuse	025-34435-000	025-34435-000	025-34435-000	

SX**	SINGLE POINT TERMINAL BLOCK
SD**	SINGLE POINT NON-FUSED DISCONNECT SWITCH
BX**	SINGLE POINT CIRCUIT BREAKER

Service Note: Locate the PANEL NUMBER sticker on the upper right hand corner of the power panel, then refer to the appropriate parts list for that number. Or, identify PIN number positions 16 and 17 on unit identification plate (See example on Page 4) then compare to table directly above for power configuration options.

***Note:** Replacement Control Board (Item 3A) should be ordered as kit #331-02550-101. (Kit contains assembled 031-02630-001 I/O Board and 031-02550-000 Control Board, as well as a Flash Card. The dual system 031-02550-000 Control Board can be used in both single and dual system YCAL units.

TABLE 16 - CONTROL AND POWER PANEL COMPONENTS (CONT'D)

ITEM	QUANTITY	DESCRIPTION	YCAL0019-40 & YCAL0019-46 YCAL0022-40 & YCAL0022-46			FIGURE	
			371-05161-102SX**	371-05161-202SD**	371-05161-302BX**		
2	1	Control Transformer	025-27911-000	025-27911-000	025-27911-000	16	
2A	1	Single Point Terminal Block	025-39423-000	N/A	N/A		
	1	Single Point Circuit Breaker	N/A	N/A	024-35973-000		
	1	Single Point NF Disconnect Switch	N/A	024-31888-000	N/A		
2B	1	Lugs	N/A	025-34478-000	025-40823-000		
2C	1	Ground Lug	025-34455-000	025-34089-000	025-34455-000		
3A	1	Control Board, IPU 2	031-02550-101*	031-02550-101*	031-02550-101*		
3B	1	Flash Card	031-02755-001	031-02755-001	031-02755-001		
4A	4	Compressor Contactor	024-35459-000	024-35459-000	024-35459-000		
4B	4	Surge Suppressor	031-00808-000	031-00808-000	031-00808-000		
4D	4	Auxiliary Contact	024-35493-000	N/A	N/A		
5	2	Control Relay	024-35526-000	024-35526-000	024-35526-000		
5A	2	Surge Suppressor	031-00808-000	031-00808-000	031-00808-000		
6B	1	Display	031-02749-000	031-02749-000	031-02749-000		17
6D	1	Switch	024-25517-000	024-25517-000	024-25517-000		
6F	1	Ribbon Cable	031-02108-000	031-02108-000	031-02108-000		
7C	4	Fan Contactor	024-35441-000	024-35441-000	024-35441-000	16	
7D	4	Surge Suppressor	031-00808-000	031-00808-000	031-00808-000		
7E	2	Fuse Block	025-37864-000	025-37864-000	025-37864-000		
7F	6	Fuse	025-34139-000	025-34139-000	025-34139-000		
10	1	Ground Bar	025-35685-000	025-35685-000	025-35685-000		
11	1	Fuse Block	025-37862-000	025-37862-000	025-37862-000		
11A	1	Fuse	025-34435-000	025-34435-000	025-34435-000		

SX**	SINGLE POINT TERMINAL BLOCK
SD**	SINGLE POINT NON-FUSED DISCONNECT SWITCH
BX**	SINGLE POINT CIRCUIT BREAKER

Service Note: Locate the PANEL NUMBER sticker on the upper right hand corner of the power panel, then refer to the appropriate parts list for that number. Or, identify PIN number positions 16 and 17 on unit identification plate (See example on Page 4) then compare to table directly above for power configuration options.

***Note:** Replacement Control Board (Item 3A) should be ordered as kit #331-02550-101. (Kit contains assembled 031-02630-001 I/O Board and 031-02550-000 Control Board, as well as a Flash Card. The dual system 031-02550-000 Control Board can be used in both single and dual system YCAL units.

TABLE 16 - CONTROL AND POWER PANEL COMPONENTS (CONT'D)

ITEM	QUANTITY	DESCRIPTION	YCAL0019-50 & YCAL0019-58 YCAL0022-50 & YCAL0022-58			FIGURE
			371-05161-102SX**	371-05161-202SD**	371-05161-302BX**	
2	1	Control Transformer	025-27911-000	025-27911-000	025-27911-000	16
2A	1	Single Point Terminal Block	025-39423-000	N/A	N/A	
	1	Single Point Circuit Breaker	N/A	N/A	024-35973-000	
	1	Single Point NF Disconnect Switch	N/A	024-31888-000	N/A	
2B	1	Lugs	N/A	025-34478-000	025-40823-000	
2C	1	Ground Lug	025-34455-000	025-34089-000	025-34455-000	
3A	1	Control Board, IPU 2	031-02550-101*	031-02550-101*	031-02550-101*	
3B	1	Flash Card	031-02755-001	031-02755-001	031-02755-001	
4A	4	Compressor Contactor	024-35459-000	024-35459-000	024-35459-000	
4B	4	Surge Suppressor	031-00808-000	031-00808-000	031-00808-000	
4D	4	Auxiliary Contact	024-35493-000	N/A	N/A	
5	2	Control Relay	024-35526-000	024-35526-000	024-35526-000	
5A	2	Surge Suppressor	031-00808-000	031-00808-000	031-00808-000	
6B	1	Display	031-02749-000	031-02749-000	031-02749-000	
6D	1	Switch	024-25517-000	024-25517-000	024-25517-000	
6F	1	Ribbon Cable	031-02108-000	031-02108-000	031-02108-000	
7C	4	Fan Contactor	024-35441-000	024-35441-000	024-35441-000	16
7D	4	Surge Suppressor	031-00808-000	031-00808-000	031-00808-000	
7E	2	Fuse Block	025-37864-000	025-37864-000	025-37864-000	
7F	6	Fuse	025-34139-000	025-34139-000	025-34139-000	
10	1	Ground Bar	025-35685-000	025-35685-000	025-35685-000	
11	1	Fuse Block	025-37862-000	025-37862-000	025-37862-000	
11A	1	Fuse	025-34435-000	025-34435-000	025-34435-000	

SX**	SINGLE POINT TERMINAL BLOCK
SD**	SINGLE POINT NON-FUSED DISCONNECT SWITCH
BX**	SINGLE POINT CIRCUIT BREAKER

Service Note: Locate the PANEL NUMBER sticker on the upper right hand corner of the power panel, then refer to the appropriate parts list for that number. Or, identify PIN number positions 16 and 17 on unit identification plate (See example on Page 4) then compare to table directly above for power configuration options.

***Note:** Replacement Control Board (Item 3A) should be ordered as kit #331-02550-101. (Kit contains assembled 031-02630-001 I/O Board and 031-02550-000 Control Board, as well as a Flash Card. The dual system 031-02550-000 Control Board can be used in both single and dual system YCAL units.

TABLE 16 - CONTROL AND POWER PANEL COMPONENTS (CONT'D)

ITEM	QUANTITY	DESCRIPTION	YCAL0028-17 & YCAL0028-28 YCAL0033-17 & YCAL0033-28			FIGURE
			371-05162-101SX**	371-05162-201SD**	371-05162-301BX**	
2	1	Control Transformer	025-27911-000	025-27911-000	025-27911-000	16
2A	1	Single Point Terminal Block	025-39386-000	N/A	N/A	
	1	Single Point Circuit Breaker	N/A	N/A	025-34419-000	
	1	Single Point NF Disconnect Switch	N/A	024-31871-000	N/A	
2B	1	Lugs	N/A	025-34480-000	025-34480-000	16
2C	1	Ground Lug	025-34089-000	025-34089-000	025-34089-000	
3A	1	Control Board, IPU 2	031-02550-101*	031-02550-101*	031-02550-101*	
3B	1	Flash Card	031-02755-001	031-02755-001	031-02755-001	
4A	4	Compressor Contactor	024-35470-000	024-35470-000	024-35470-000	
4B	4	Surge Suppressor	031-00808-000	031-00808-000	031-00808-000	
4D	4	Auxiliary Contact	024-35493-000	N/A	N/A	
5	2	Control Relay	024-35526-000	024-35526-000	024-35526-000	17
5A	2	Surge Suppressor	031-00808-000	031-00808-000	031-00808-000	
6B	1	Display	031-02749-000	031-02749-000	031-02749-000	
6D	1	Switch	024-25517-000	024-25517-000	024-25517-000	
6F	1	Ribbon Cable	031-02108-000	031-02108-000	031-02108-000	16
7C	4	Fan Contactor	024-35444-000	024-35444-000	024-35444-000	
7D	4	Surge Suppressor	031-00808-000	031-00808-000	031-00808-000	
7E	2	Fuse Block	025-37863-000	025-37863-000	025-37863-000	
7F	6	Fuse	025-34142-000	025-34142-000	025-34142-000	
10	1	Ground Bar	025-35685-000	025-35685-000	025-35685-000	
11	1	Fuse Block	025-37862-000	025-37862-000	025-37862-000	
11A	1	Fuse	025-34435-000	025-34435-000	025-34435-000	

SX**	SINGLE POINT TERMINAL BLOCK
SD**	SINGLE POINT NON-FUSED DISCONNECT SWITCH
BX**	SINGLE POINT CIRCUIT BREAKER

Service Note: Locate the PANEL NUMBER sticker on the upper right hand corner of the power panel, then refer to the appropriate parts list for that number. Or, identify PIN number positions 16 and 17 on unit identification plate (See example on Page 4) then compare to table directly above for power configuration options.

***Note:** Replacement Control Board (Item 3A) should be ordered as kit #331-02550-101. (Kit contains assembled 031-02630-001 I/O Board and 031-02550-000 Control Board, as well as a Flash Card. The dual system 031-02550-000 Control Board can be used in both single and dual system YCAL units.

TABLE 16 - CONTROL AND POWER PANEL COMPONENTS (CONT'D)

ITEM	QUANTITY	DESCRIPTION	YCAL0028-40 & YCAL0028-46 YCAL0033-40 & YCAL0033-46			FIGURE
			371-05162-102SX**	371-05162-202SD**	371-05162-302BX**	
			2	1	Control Transformer	
2A	1	Single Point Terminal Block	025-39423-000	N/A	N/A	
	1	Single Point Circuit Breaker	N/A	N/A	025-34419-000	
	1	Single Point NF Disconnect Switch	N/A	024-31888-000	N/A	
2B	1	Lugs	N/A	025-34478-000	025-34418-000	16
2C	1	Ground Lug	025-34089-000	025-34089-000	025-34089-000	
3A	1	Control Board, IPU 2	031-02550-101*	031-02550-101*	031-02550-101*	
3B	1	Flash Card	031-02755-001	031-02755-001	031-02755-001	
4A	4	Compressor Contactor	024-35462-000	024-35462-000	024-35462-000	16
4B	4	Surge Suppressor	031-00808-000	031-00808-000	031-00808-000	
4D	4	Auxiliary Contact	N/A	N/A	N/A	
5	2	Control Relay	024-35526-000	024-35526-000	024-35526-000	
5A	2	Surge Suppressor	031-00808-000	031-00808-000	031-00808-000	17
6B	1	Display	031-02749-000	031-02749-000	031-02749-000	
6D	1	Switch	024-25517-000	024-25517-000	024-25517-000	
6F	1	Ribbon Cable	031-02108-000	031-02108-000	031-02108-000	
7C	4	Fan Contactor	024-35444-000	024-35441-000	024-35441-000	16
7D	4	Surge Suppressor	031-00808-000	031-00808-000	031-00808-000	
7E	2	Fuse Block	025-37863-000	025-37863-000	025-37863-000	
7F	6	Fuse	025-34142-000	025-34142-000	025-34142-000	
10	1	Ground Bar	025-35685-000	025-35685-000	025-35685-000	16
11	1	Fuse Block	025-37862-000	025-37862-000	025-37862-000	
11A	1	Fuse	025-34435-000	025-34435-000	025-34435-000	

SX**	SINGLE POINT TERMINAL BLOCK
SD**	SINGLE POINT NON-FUSED DISCONNECT SWITCH
BX**	SINGLE POINT CIRCUIT BREAKER

Service Note: Locate the PANEL NUMBER sticker on the upper right hand corner of the power panel, then refer to the appropriate parts list for that number. Or, identify PIN number positions 16 and 17 on unit identification plate (See example on Page 4) then compare to table directly above for power configuration options.

***Note:** Replacement Control Board (Item 3A) should be ordered as kit #331-02550-101. (Kit contains assembled 031-02630-001 I/O Board and 031-02550-000 Control Board, as well as a Flash Card. The dual system 031-02550-000 Control Board can be used in both single and dual system YCAL units.

TABLE 16 - CONTROL AND POWER PANEL COMPONENTS (CONT'D)

ITEM	QUANTITY	DESCRIPTION	YCAL0028-50 & YCAL0028-58 YCAL0033-50 & YCAL0033-58			FIGURE
			371-05162-102SX**	371-05162-202SD**	371-05162-302BX**	
2	1	Control Transformer	025-27911-000	025-27911-000	025-27911-000	16
2A	1	Single Point Terminal Block	025-39423-000	N/A	N/A	
	1	Single Point Circuit Breaker	N/A	N/A	025-34419-000	
	1	Single Point NF Disconnect Switch	N/A	024-31888-000	N/A	
2B	1	Lugs	N/A	025-34478-000	025-34418-000	16
2C	1	Ground Lug	025-34089-000	025-34089-000	025-34089-000	
3A	1	Control Board, IPU 2	031-02550-101*	031-02550-101*	031-02550-101*	
3B	1	Flash Card	031-02755-001	031-02755-001	031-02755-001	
4A	4	Compressor Contactor	024-35462-000	024-35462-000	024-35462-000	
4B	4	Surge Suppressor	031-00808-000	031-00808-000	031-00808-000	
4D	4	Auxiliary Contact	N/A	N/A	N/A	
5	2	Control Relay	024-35526-000	024-35526-000	024-35526-000	
5A	2	Surge Suppressor	031-00808-000	031-00808-000	031-00808-000	
6B	1	Display	031-02749-000	031-02749-000	031-02749-000	
6D	1	Switch	024-25517-000	024-25517-000	024-25517-000	
6F	1	Ribbon Cable	031-02108-000	031-02108-000	031-02108-000	
7C	4	Fan Contactor	024-35444-000	024-35441-000	024-35441-000	16
7D	4	Surge Suppressor	031-00808-000	031-00808-000	031-00808-000	
7E	2	Fuse Block	025-37863-000	025-37863-000	025-37863-000	
7F	6	Fuse	025-34142-000	025-34142-000	025-34142-000	
10	1	Ground Bar	025-35685-000	025-35685-000	025-35685-000	
11	1	Fuse Block	025-37862-000	025-37862-000	025-37862-000	
11A	1	Fuse	025-34435-000	025-34435-000	025-34435-000	

SX**	SINGLE POINT TERMINAL BLOCK
SD**	SINGLE POINT NON-FUSED DISCONNECT SWITCH
BX**	SINGLE POINT CIRCUIT BREAKER

Service Note: Locate the PANEL NUMBER sticker on the upper right hand corner of the power panel, then refer to the appropriate parts list for that number. Or, identify PIN number positions 16 and 17 on unit identification plate (See example on Page 4) then compare to table directly above for power configuration options.

***Note:** Replacement Control Board (Item 3A) should be ordered as kit #331-02550-101. (Kit contains assembled 031-02630-001 I/O Board and 031-02550-000 Control Board, as well as a Flash Card. The dual system 031-02550-000 Control Board can be used in both single and dual system YCAL units.

TABLE 16 - CONTROL AND POWER PANEL COMPONENTS (CONT'D)

ITEM	QUANTITY	DESCRIPTION	YCAL0043-17 & YCAL0043-28 YCAL0046-17 & YCAL0046-28			FIGURE
			371-05163-101SX**	371-05163-201SD**	371-05163-301BX**	
2	1	Control Transformer	025-27911-000	025-27911-000	025-27911-000	16
2A	1	Single Point Terminal Block	025-39410-000	N/A	N/A	
	1	Single Point Circuit Breaker	N/A	N/A	025-34424-000	
	1	Single Point NF Disconnect Switch	N/A	024-30964-000	N/A	
2B	1	Lugs	N/A	025-34420-000	025-34420-000	
2C	1	Ground Lug	025-34089-000	025-34089-000	025-34089-000	
3A	1	Control Board, IPU 2	031-02550-101*	031-02550-101*	031-02550-101*	
3B	1	Flash Card	031-02755-001	031-02755-001	031-02755-001	
4A	4	Compressor Contactor	024-35467-000	024-35467-000	024-35467-000	
4B	4	Surge Suppressor	031-00808-000	031-00808-000	031-00808-000	
4D	4	Auxiliary Contact	024-35493-000	N/A	N/A	
5	2	Control Relay	024-35526-000	024-35526-000	024-35526-000	
5A	2	Surge Suppressor	031-00808-000	031-00808-000	031-00808-000	
6B	1	Display	031-02749-000	031-02749-000	031-02749-000	17
6D	1	Switch	024-25517-000	024-25517-000	024-25517-000	
6F	1	Ribbon Cable	031-02108-000	031-02108-000	031-02108-000	
7C	4	Fan Contactor	024-35444-000	024-35444-000	024-35444-000	16
7D	4	Surge Suppressor	031-00808-000	031-00808-000	031-00808-000	
7E	2	Fuse Block	025-37863-000	025-37863-000	025-37863-000	
7F	6	Fuse	025-34142-000	025-34142-000	025-34142-000	
10	1	Ground Bar	025-35685-000	025-35685-000	025-35685-000	
11	1	Fuse Block	025-37862-000	025-37862-000	025-37862-000	
11A	1	Fuse	025-34435-000	025-34435-000	025-34435-000	

SX**	SINGLE POINT TERMINAL BLOCK
SD**	SINGLE POINT NON-FUSED DISCONNECT SWITCH
BX**	SINGLE POINT CIRCUIT BREAKER

Service Note: Locate the PANEL NUMBER sticker on the upper right hand corner of the power panel, then refer to the appropriate parts list for that number. Or, identify PIN number positions 16 and 17 on unit identification plate (See example on Page 4) then compare to table directly above for power configuration options.

***Note:** Replacement Control Board (Item 3A) should be ordered as kit #331-02550-101. (Kit contains assembled 031-02630-001 I/O Board and 031-02550-000 Control Board, as well as a Flash Card. The dual system 031-02550-000 Control Board can be used in both single and dual system YCAL units.

TABLE 16 - CONTROL AND POWER PANEL COMPONENTS (CONT'D)

ITEM	QUANTITY	DESCRIPTION	YCAL0043-40 & YCAL0043-46 YCAL0046-40 & YCAL0046-46			FIGURE
			371-05163-102SX**	371-05163-202SD**	371-05163-302BX**	
2	1	Control Transformer	025-27911-000	025-27911-000	025-27911-000	16
2A	1	Single Point Terminal Block	025-39423-000	N/A	N/A	
	1	Single Point Circuit Breaker	N/A	N/A	025-34419-000	
	1	Single Point NF Disconnect Switch	N/A	024-31888-000	N/A	
2B	1	Lugs	N/A	025-34480-000	025-34418-000	
2C	1	Ground Lug	025-34089-000	025-34089-000	025-34089-000	
3A	1	Control Board, IPU 2	031-02550-101*	031-02550-101*	031-02550-101*	
3B	1	Flash Card	031-02755-001	031-02755-001	031-02755-001	
4A	4	Compressor Contactor	024-35459-000	024-35459-000	024-35459-000	
4B	4	Surge Suppressor	031-00808-000	031-00808-000	031-00808-000	
4D	4	Auxiliary Contact	024-35493-000	N/A	N/A	
5	2	Control Relay	024-35526-000	024-35526-000	024-35526-000	
5A	2	Surge Suppressor	031-00808-000	031-00808-000	031-00808-000	
6B	1	Display	031-02749-000	031-02749-000	031-02749-000	17
6D	1	Switch	024-25517-000	024-25517-000	024-25517-000	
6F	1	Ribbon Cable	031-02108-000	031-02108-000	031-02108-000	
7C	4	Fan Contactor	024-35441-000	024-35441-000	024-35441-000	16
7D	4	Surge Suppressor	031-00808-000	031-00808-000	031-00808-000	
7E	2	Fuse Block	025-37863-000	025-37863-000	025-37863-000	
7F	6	Fuse	025-34142-000	025-34142-000	025-34142-000	
10	1	Ground Bar	025-35685-000	025-35685-000	025-35685-000	
11	1	Fuse Block	025-37862-000	025-37862-000	025-37862-000	
11A	1	Fuse	025-34435-000	025-34435-000	025-34435-000	

SX**	SINGLE POINT TERMINAL BLOCK
SD**	SINGLE POINT NON-FUSED DISCONNECT SWITCH
BX**	SINGLE POINT CIRCUIT BREAKER

Service Note: Locate the PANEL NUMBER sticker on the upper right hand corner of the power panel, then refer to the appropriate parts list for that number. Or, identify PIN number positions 16 and 17 on unit identification plate (See example on Page 4) then compare to table directly above for power configuration options.

***Note:** Replacement Control Board (Item 3A) should be ordered as kit #331-02550-101. (Kit contains assembled 031-02630-001 I/O Board and 031-02550-000 Control Board, as well as a Flash Card. The dual system 031-02550-000 Control Board can be used in both single and dual system YCAL units.

TABLE 16 - CONTROL AND POWER PANEL COMPONENTS (CONT'D)

ITEM	QUANTITY	DESCRIPTION	YCAL0043-50 & YCAL0043-58 YCAL0046-50 & YCAL0046-58			FIGURE
			371-05163-102SX**	371-05163-202SD**	371-05163-302BX**	
2	1	Control Transformer	025-27911-000	025-27911-000	025-27911-000	16
2A	1	Single Point Terminal Block	025-39423-000	N/A	N/A	
	1	Single Point Circuit Breaker	N/A	N/A	025-34419-000	
	1	Single Point NF Disconnect Switch	N/A	024-31888-000	N/A	
2B	1	Lugs	N/A	025-34480-000	025-34418-000	
2C	1	Ground Lug	025-34089-000	025-34089-000	025-34089-000	
3A	1	Control Board, IPU 2	031-02550-101*	031-02550-101*	031-02550-101*	
3B	1	Flash Card	031-02755-001	031-02755-001	031-02755-001	
4A	4	Compressor Contactor	024-35459-000	024-35459-000	024-35459-000	
4B	4	Surge Suppressor	031-00808-000	031-00808-000	031-00808-000	
4D	4	Auxiliary Contact	024-35493-000	N/A	N/A	
5	2	Control Relay	024-35526-000	024-35526-000	024-35526-000	
5A	2	Surge Suppressor	031-00808-000	031-00808-000	031-00808-000	
6B	1	Display	031-02749-000	031-02749-000	031-02749-000	17
6D	1	Switch	024-25517-000	024-25517-000	024-25517-000	
6F	1	Ribbon Cable	031-02108-000	031-02108-000	031-02108-000	
7C	4	Fan Contactor	024-35441-000	024-35441-000	024-35441-000	16
7D	4	Surge Suppressor	031-00808-000	031-00808-000	031-00808-000	
7E	2	Fuse Block	025-37863-000	025-37863-000	025-37863-000	
7F	6	Fuse	025-34142-000	025-34142-000	025-34142-000	
10	1	Ground Bar	025-35685-000	025-35685-000	025-35685-000	
11	1	Fuse Block	025-37862-000	025-37862-000	025-37862-000	
11A	1	Fuse	025-34435-000	025-34435-000	025-34435-000	

SX**	SINGLE POINT TERMINAL BLOCK
SD**	SINGLE POINT NON-FUSED DISCONNECT SWITCH
BX**	SINGLE POINT CIRCUIT BREAKER

Service Note: Locate the PANEL NUMBER sticker on the upper right hand corner of the power panel, then refer to the appropriate parts list for that number. Or, identify PIN number positions 16 and 17 on unit identification plate (See example on Page 4) then compare to table directly above for power configuration options.

***Note:** Replacement Control Board (Item 3A) should be ordered as kit #331-02550-101. (Kit contains assembled 031-02630-001 I/O Board and 031-02550-000 Control Board, as well as a Flash Card. The dual system 031-02550-000 Control Board can be used in both single and dual system YCAL units.

TABLE 16 - CONTROL AND POWER PANEL COMPONENTS (CONT'D)

ITEM	QUANTITY	DESCRIPTION	YCAL0052-17, YCAL0052-28 & YCAL0052-40 YCAL0056-17, YCAL0056-28 & YCAL0056-40			FIGURE
			371-05163-103SX**	371-05163-203SD**	371-05163-303BX**	
2	1	Control Transformer	025-27911-000	025-27911-000	025-27911-000	16
2A	1	Single Point Terminal Block	025-39410-000	N/A	N/A	
	1	Single Point Circuit Breaker	N/A	N/A	025-34424-000	
	1	Single Point NF Disconnect Switch	N/A	024-30964-000	N/A	
2B	1	Lugs	N/A	025-34481-000	025-34481-000	
2C	1	Ground Lug	025-34089-000	025-34089-000	025-34089-000	
3A	1	Control Board, IPU 2	031-02550-101*	031-02550-101*	031-02550-101*	
3B	1	Flash Card	031-02755-001	031-02755-001	031-02755-001	
4A	4	Compressor Contactor	024-35473-000	024-35473-000	024-35473-000	
4B	4	Surge Suppressor	031-00808-000	031-00808-000	031-00808-000	
4D	4	Auxiliary Contact	024-35493-000	N/A	N/A	
5	2	Control Relay	024-35526-000	024-35526-000	024-35526-000	
5A	2	Surge Suppressor	031-00808-000	031-00808-000	031-00808-000	
6B	1	Display	031-02749-000	031-02749-000	031-02749-000	17
6D	1	Switch	024-25517-000	024-25517-000	024-25517-000	
6F	1	Ribbon Cable	031-02108-000	031-02108-000	031-02108-000	
7C	4	Fan Contactor	024-35444-000	024-35444-000	024-35444-000	16
7D	4	Surge Suppressor	031-00808-000	031-00808-000	031-00808-000	
7E	2	Fuse Block	025-37863-000	025-37863-000	025-37863-000	
7F	6	Fuse	025-34142-000	025-34142-000	025-34142-000	
10	1	Ground Bar	025-35685-000	025-35685-000	025-35685-000	
11	1	Fuse Block	025-37862-000	025-37862-000	025-37862-000	
11A	1	Fuse	025-34435-000	025-34435-000	025-34435-000	

SX**	SINGLE POINT TERMINAL BLOCK
SD**	SINGLE POINT NON-FUSED DISCONNECT SWITCH
BX**	SINGLE POINT CIRCUIT BREAKER

Service Note: Locate the PANEL NUMBER sticker on the upper right hand corner of the power panel, then refer to the appropriate parts list for that number. Or, identify PIN number positions 16 and 17 on unit identification plate (See example on Page 4) then compare to table directly above for power configuration options.

***Note:** Replacement Control Board (Item 3A) should be ordered as kit #331-02550-101. (Kit contains assembled 031-02630-001 I/O Board and 031-02550-000 Control Board, as well as a Flash Card. The dual system 031-02550-000 Control Board can be used in both single and dual system YCAL units.

TABLE 16 - CONTROL AND POWER PANEL COMPONENTS (CONT'D)

ITEM	QUANTITY	DESCRIPTION	YCAL0052-46YCAL0056-46			FIGURE
			371-05163-102SX**	371-05163-202SD**	371-05163-302BX**	
2	1	Control Transformer	025-27911-000	025-27911-000	025-27911-000	16
2A	1	Single Point Terminal Block	025-39423-000	N/A	N/A	
	1	Single Point Circuit Breaker	N/A	N/A	025-34419-000	
	1	Single Point NF Disconnect Switch	N/A	024-31888-000	N/A	
2B	1	Lugs	N/A	025-34480-000	025-34418-000	
2C	1	Ground Lug	025-34089-000	025-34089-000	025-34089-000	
3A	1	Control Board, IPU 2	031-02550-101*	031-02550-101*	031-02550-101*	
3B	1	Flash Card	031-02755-001	031-02755-001	031-02755-001	
4A	4	Compressor Contactor	024-35459-000	024-35459-000	024-35459-000	
4B	4	Surge Suppressor	031-00808-000	031-00808-000	031-00808-000	
4D	4	Auxiliary Contact	024-35493-000	N/A	N/A	
5	2	Control Relay	024-35526-000	024-35526-000	024-35526-000	
5A	2	Surge Suppressor	031-00808-000	031-00808-000	031-00808-000	
6B	1	Display	031-02749-000	031-02749-000	031-02749-000	
6D	1	Switch	024-25517-000	024-25517-000	024-25517-000	
6F	1	Ribbon Cable	031-02108-000	031-02108-000	031-02108-000	
7C	4	Fan Contactor	024-35441-000	024-35441-000	024-35441-000	16
7D	4	Surge Suppressor	031-00808-000	031-00808-000	031-00808-000	
7E	2	Fuse Block	025-37863-000	025-37863-000	025-37863-000	
7F	6	Fuse	025-34142-000	025-34142-000	025-34142-000	
10	1	Ground Bar	025-35685-000	025-35685-000	025-35685-000	
11	1	Fuse Block	025-37862-000	025-37862-000	025-37862-000	
11A	1	Fuse	025-34435-000	025-34435-000	025-34435-000	

SX**	SINGLE POINT TERMINAL BLOCK
SD**	SINGLE POINT NON-FUSED DISCONNECT SWITCH
BX**	SINGLE POINT CIRCUIT BREAKER

Service Note: Locate the PANEL NUMBER sticker on the upper right hand corner of the power panel, then refer to the appropriate parts list for that number. Or, identify PIN number positions 16 and 17 on unit identification plate (See example on Page 4) then compare to table directly above for power configuration options.

***Note:** Replacement Control Board (Item 3A) should be ordered as kit #331-02550-101. (Kit contains assembled 031-02630-001 I/O Board and 031-02550-000 Control Board, as well as a Flash Card. The dual system 031-02550-000 Control Board can be used in both single and dual system YCAL units.

TABLE 16 - CONTROL AND POWER PANEL COMPONENTS (CONT'D)

ITEM	QUANTITY	DESCRIPTION	YCAL0052-50 & YCAL0052-58 YCAL0056-50 & YCAL0056-58			FIGURE
			371-05163-102SX**	371-05163-202SD**	371-05163-302BX**	
2	1	Control Transformer	025-27911-000	025-27911-000	025-27911-000	16
2A	1	Single Point Terminal Block	025-39423-000	N/A	N/A	
	1	Single Point Circuit Breaker	N/A	N/A	025-34419-000	
	1	Single Point NF Disconnect Switch	N/A	024-31888-000	N/A	
2B	1	Lugs	N/A	025-34480-000	025-34418-000	
2C	1	Ground Lug	025-34089-000	025-34089-000	025-34089-000	
3A	1	Control Board, IPU 2	031-02550-101*	031-02550-101*	031-02550-101*	
3B	1	Flash Card	031-02755-001	031-02755-001	031-02755-001	
4A	4	Compressor Contactor	024-35459-000	024-35459-000	024-35459-000	
4B	4	Surge Suppressor	031-00808-000	031-00808-000	031-00808-000	
4D	4	Auxiliary Contact	024-35493-000	N/A	N/A	
5	2	Control Relay	024-35526-000	024-35526-000	024-35526-000	
5A	2	Surge Suppressor	031-00808-000	031-00808-000	031-00808-000	
6B	1	Display	031-02749-000	031-02749-000	031-02749-000	17
6D	1	Switch	024-25517-000	024-25517-000	024-25517-000	
6F	1	Ribbon Cable	031-02108-000	031-02108-000	031-02108-000	
7C	4	Fan Contactor	024-35441-000	024-35441-000	024-35441-000	16
7D	4	Surge Suppressor	031-00808-000	031-00808-000	031-00808-000	
7E	2	Fuse Block	025-37863-000	025-37863-000	025-37863-000	
7F	6	Fuse	025-34142-000	025-34142-000	025-34142-000	
10	1	Ground Bar	025-35685-000	025-35685-000	025-35685-000	
11	1	Fuse Block	025-37862-000	025-37862-000	025-37862-000	
11A	1	Fuse	025-34435-000	025-34435-000	025-34435-000	

SX**	SINGLE POINT TERMINAL BLOCK
SD**	SINGLE POINT NON-FUSED DISCONNECT SWITCH
BX**	SINGLE POINT CIRCUIT BREAKER

Service Note: Locate the PANEL NUMBER sticker on the upper right hand corner of the power panel, then refer to the appropriate parts list for that number. Or, identify PIN number positions 16 and 17 on unit identification plate (See example on Page 4) then compare to table directly above for power configuration options.

***Note:** Replacement Control Board (Item 3A) should be ordered as kit #331-02550-101. (Kit contains assembled 031-02630-001 I/O Board and 031-02550-000 Control Board, as well as a Flash Card. The dual system 031-02550-000 Control Board can be used in both single and dual system YCAL units.

TABLE 16 - CONTROL AND POWER PANEL COMPONENTS (CONT'D)

ITEM	QUANTITY	DESCRIPTION	YCAL0066-17 & YCAL0066-28			FIGURE
			371-05163-103SX**	371-05163-203SD**	371-05163-303BX**	
2	1	Control Transformer	025-27911-000	025-27911-000	025-27911-000	16
2A	1	Single Point Terminal Block	025-39410-000	N/A	N/A	
	1	Single Point Circuit Breaker	N/A	N/A	025-34424-000	
	1	Single Point NF Disconnect Switch	N/A	024-30964-000	N/A	
2B	1	Lugs	N/A	025-34481-000	025-34481-000	
2C	1	Ground Lug	025-34089-000	025-34089-000	025-34089-000	
3A	1	Control Board, IPU 2	031-02550-101*	031-02550-101*	031-02550-101*	
3B	1	Flash Card	031-02755-001	031-02755-001	031-02755-001	
4A	4	Compressor Contactor	024-35473-000	024-35473-000	024-35473-000	
4B	4	Surge Suppressor	031-00808-000	031-00808-000	031-00808-000	
4D	4	Auxiliary Contact	024-35493-000	N/A	N/A	
5	2	Control Relay	024-35526-000	024-35526-000	024-35526-000	
5A	2	Surge Suppressor	031-00808-000	031-00808-000	031-00808-000	
6B	1	Display	031-02749-000	031-02749-000	031-02749-000	17
6D	1	Switch	024-25517-000	024-25517-000	024-25517-000	
6F	1	Ribbon Cable	031-02108-000	031-02108-000	031-02108-000	
7C	4	Fan Contactor	024-35444-000	024-35444-000	024-35444-000	16
7D	4	Surge Suppressor	031-00808-000	031-00808-000	031-00808-000	
7E	2	Fuse Block	025-37863-000	025-37863-000	025-37863-000	
7F	6	Fuse	025-34142-000	025-34142-000	025-34142-000	
10	1	Ground Bar	025-35685-000	025-35685-000	025-35685-000	
11	1	Fuse Block	025-37862-000	025-37862-000	025-37862-000	
11A	1	Fuse	025-34435-000	025-34435-000	025-34435-000	

SX**	SINGLE POINT TERMINAL BLOCK
SD**	SINGLE POINT NON-FUSED DISCONNECT SWITCH
BX**	SINGLE POINT CIRCUIT BREAKER

Service Note: **Locate the PANEL NUMBER sticker on the upper right hand corner of the power panel, then refer to the appropriate parts list** for that number. Or, identify PIN number positions 16 and 17 on unit identification plate (See example on Page 4) then compare to table directly above for power configuration options.

***Note:** Replacement Control Board (Item 3A) should be ordered as kit #331-02550-101. (Kit contains assembled 031-02630-001 I/O Board and 031-02550-000 Control Board, as well as a Flash Card. The dual system 031-02550-000 Control Board can be used in both single and dual system YCAL units.

TABLE 16 - CONTROL AND POWER PANEL COMPONENTS (CONT'D)

ITEM	QUANTITY	DESCRIPTION	YCAL0066-40 & YCAL0066-46			FIGURE
			371-05163-104SX**	371-05163-204SD**	371-05163-304BX**	
2	1	Control Transformer	025-27911-000	025-27911-000	025-27911-000	16
2A	1	Single Point Terminal Block	025-39386-000	N/A	N/A	
	1	Single Point Circuit Breaker	N/A	N/A	025-34419-000	
	1	Single Point NF Disconnect Switch	N/A	024-30963-000	N/A	
2B	1	Lugs	N/A	025-34418-000	025-34418-000	
2C	1	Ground Lug	025-34089-000	025-34089-000	025-34089-000	
3A	1	Control Board, IPU 2	031-02550-101*	031-02550-101*	031-02550-101*	
3B	1	Flash Card	031-02755-001	031-02755-001	031-02755-001	
4A	4	Compressor Contactor	024-35467-000	024-35467-000	024-35467-000	
4B	4	Surge Suppressor	031-00808-000	031-00808-000	031-00808-000	
4D	4	Auxiliary Contact	N/A	N/A	N/A	
5	2	Control Relay	024-35526-000	024-35526-000	024-35526-000	
5A	2	Surge Suppressor	031-00808-000	031-00808-000	031-00808-000	
6B	1	Display	031-02749-000	031-02749-000	031-02749-000	17
6D	1	Switch	024-25517-000	024-25517-000	024-25517-000	
6F	1	Ribbon Cable	031-02108-000	031-02108-000	031-02108-000	
7C	4	Fan Contactor	024-35441-000	024-35441-000	024-35441-000	16
7D	4	Surge Suppressor	031-00808-000	031-00808-000	031-00808-000	
7E	2	Fuse Block	025-37863-000	025-37863-000	025-37863-000	
7F	6	Fuse	025-34142-000	025-34142-000	025-34142-000	
10	1	Ground Bar	025-35685-000	025-35685-000	025-35685-000	
11	1	Fuse Block	025-37862-000	025-37862-000	025-37862-000	
11A	1	Fuse	025-34435-000	025-34435-000	025-34435-000	

SX**	SINGLE POINT TERMINAL BLOCK
SD**	SINGLE POINT NON-FUSED DISCONNECT SWITCH
BX**	SINGLE POINT CIRCUIT BREAKER

Service Note: Locate the PANEL NUMBER sticker on the upper right hand corner of the power panel, then refer to the appropriate parts list for that number. Or, identify PIN number positions 16 and 17 on unit identification plate (See example on Page 4) then compare to table directly above for power configuration options.

***Note:** Replacement Control Board (Item 3A) should be ordered as kit #331-02550-101. (Kit contains assembled 031-02630-001 I/O Board and 031-02550-000 Control Board, as well as a Flash Card. The dual system 031-02550-000 Control Board can be used in both single and dual system YCAL units.

TABLE 16 - CONTROL AND POWER PANEL COMPONENTS (CONT'D)

ITEM	QUANTITY	DESCRIPTION	YCAL0066-50 & YCAL0066-58			FIGURE
			371-05163-104SX**	371-05163-204SD**	371-05163-304BX**	
2	1	Control Transformer	025-27911-000	025-27911-000	025-27911-000	16
2A	1	Single Point Terminal Block	025-39386-000	N/A	N/A	
	1	Single Point Circuit Breaker	N/A	N/A	025-34419-000	
	1	Single Point NF Disconnect Switch	N/A	024-30963-000	N/A	
2B	1	Lugs	N/A	025-34418-000	025-34418-000	
2C	1	Ground Lug	025-34089-000	025-34089-000	025-34089-000	
3A	1	Control Board, IPU 2	031-02550-101*	031-02550-101*	031-02550-101*	
3B	1	Flash Card	031-02755-001	031-02755-001	031-02755-001	
4A	4	Compressor Contactor	024-35467-000	024-35467-000	024-35467-000	
4B	4	Surge Suppressor	031-00808-000	031-00808-000	031-00808-000	
4D	4	Auxiliary Contact	N/A	N/A	N/A	
5	2	Control Relay	024-35526-000	024-35526-000	024-35526-000	
5A	2	Surge Suppressor	031-00808-000	031-00808-000	031-00808-000	
6B	1	Display	031-02749-000	031-02749-000	031-02749-000	17
6D	1	Switch	024-25517-000	024-25517-000	024-25517-000	
6F	1	Ribbon Cable	031-02108-000	031-02108-000	031-02108-000	
7C	4	Fan Contactor	024-35441-000	024-35441-000	024-35441-000	16
7D	4	Surge Suppressor	031-00808-000	031-00808-000	031-00808-000	
7E	2	Fuse Block	025-37863-000	025-37863-000	025-37863-000	
7F	6	Fuse	025-34142-000	025-34142-000	025-34142-000	
10	1	Ground Bar	025-35685-000	025-35685-000	025-35685-000	
11	1	Fuse Block	025-37862-000	025-37862-000	025-37862-000	
11A	1	Fuse	025-34435-000	025-34435-000	025-34435-000	

SX**	SINGLE POINT TERMINAL BLOCK
SD**	SINGLE POINT NON-FUSED DISCONNECT SWITCH
BX**	SINGLE POINT CIRCUIT BREAKER

Service Note: Locate the PANEL NUMBER sticker on the upper right hand corner of the power panel, then refer to the appropriate parts list for that number. Or, identify PIN number positions 16 and 17 on unit identification plate (See example on Page 4) then compare to table directly above for power configuration options.

***Note:** Replacement Control Board (Item 3A) should be ordered as kit #331-02550-101. (Kit contains assembled 031-02630-001 I/O Board and 031-02550-000 Control Board, as well as a Flash Card. The dual system 031-02550-000 Control Board can be used in both single and dual system YCAL units.

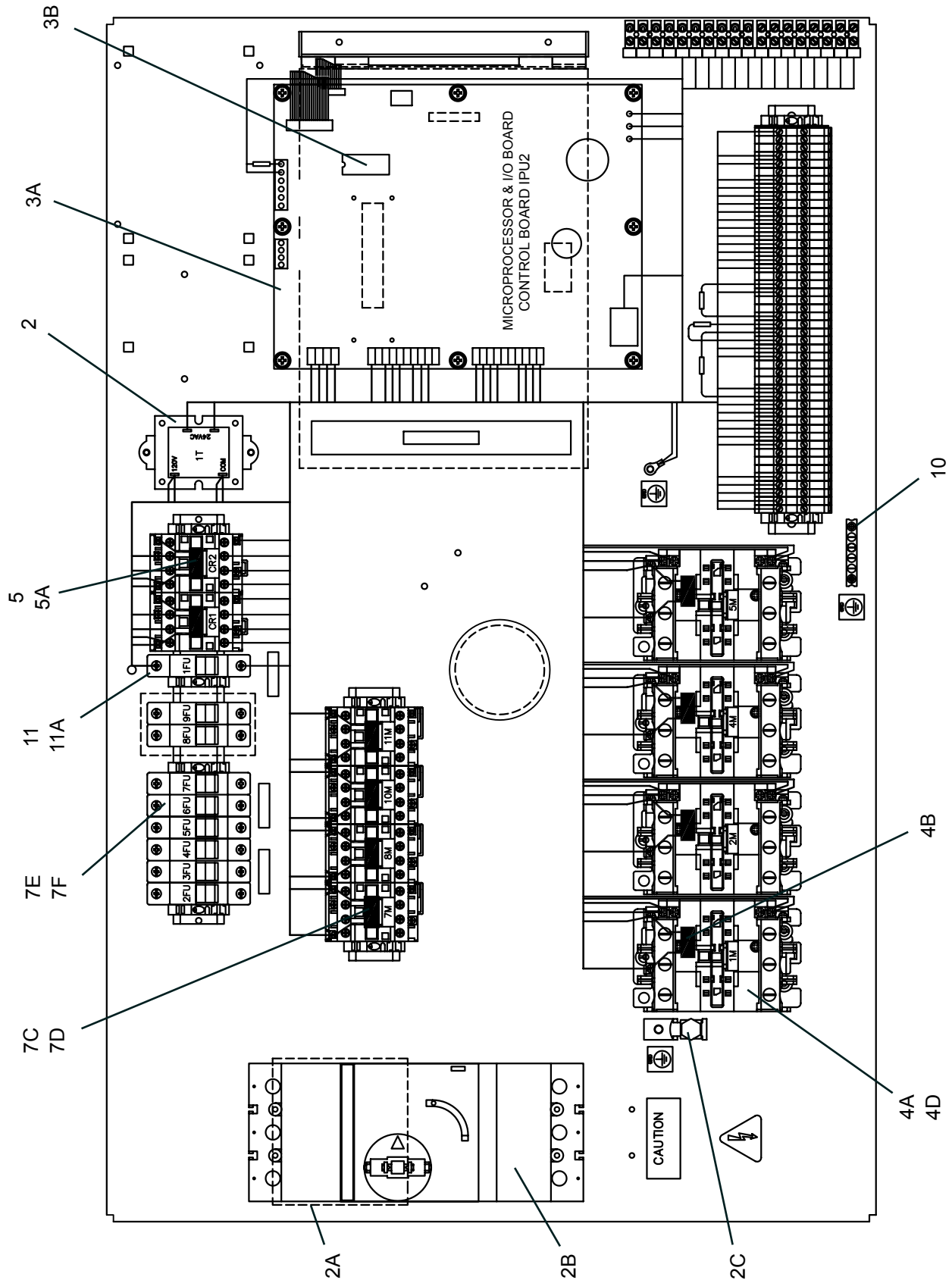

206985-sht1

FIGURE 16 - CONTROL AND POWER PANEL COMPONENTS (CONTROL BOARD)

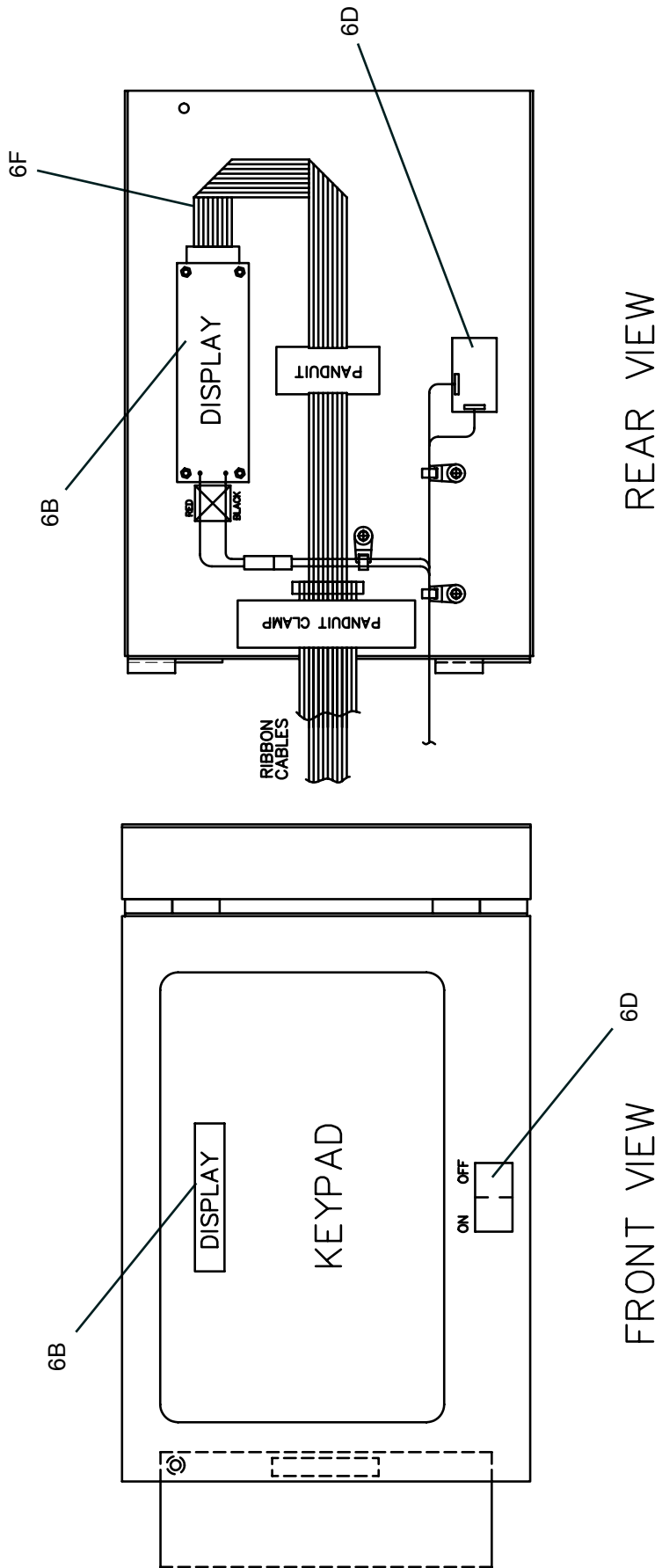

202777-3

FIGURE 17 - CONTROL AND POWER PANEL COMPONENTS (FRONT AND REAR VIEW)

SECTION 8 - WIRING HARNESSSES

TABLE 17 - CONTROL WIRING HARNESSSES

ITEM	DESCRIPTION	SYSTEM	YCAL	PART NUMBER	FIGURE
1	HARNESS, LIQUID LINE SOLENOID VALVE	#1	0019-0022	575-57126-231	18
			0028-0033	575-57126-231	
			0043-0052	575-57126-215	
			0056-0066	575-57126-208	
2	HARNESS, LIQUID LINE SOLENOID VALVE	#2	0019-0022	N/A	
			0028-0033	N/A	
			0043-0052	575-57126-216	
			0056-0066	575-57126-209	
3	HARNESS, HIGH PRESSURE CUT OUT*	#1	ALL	575-57126-244	
4	HARNESS, HIGH PRESSURE CUT OUT*	#2	ALL	575-57126-244	

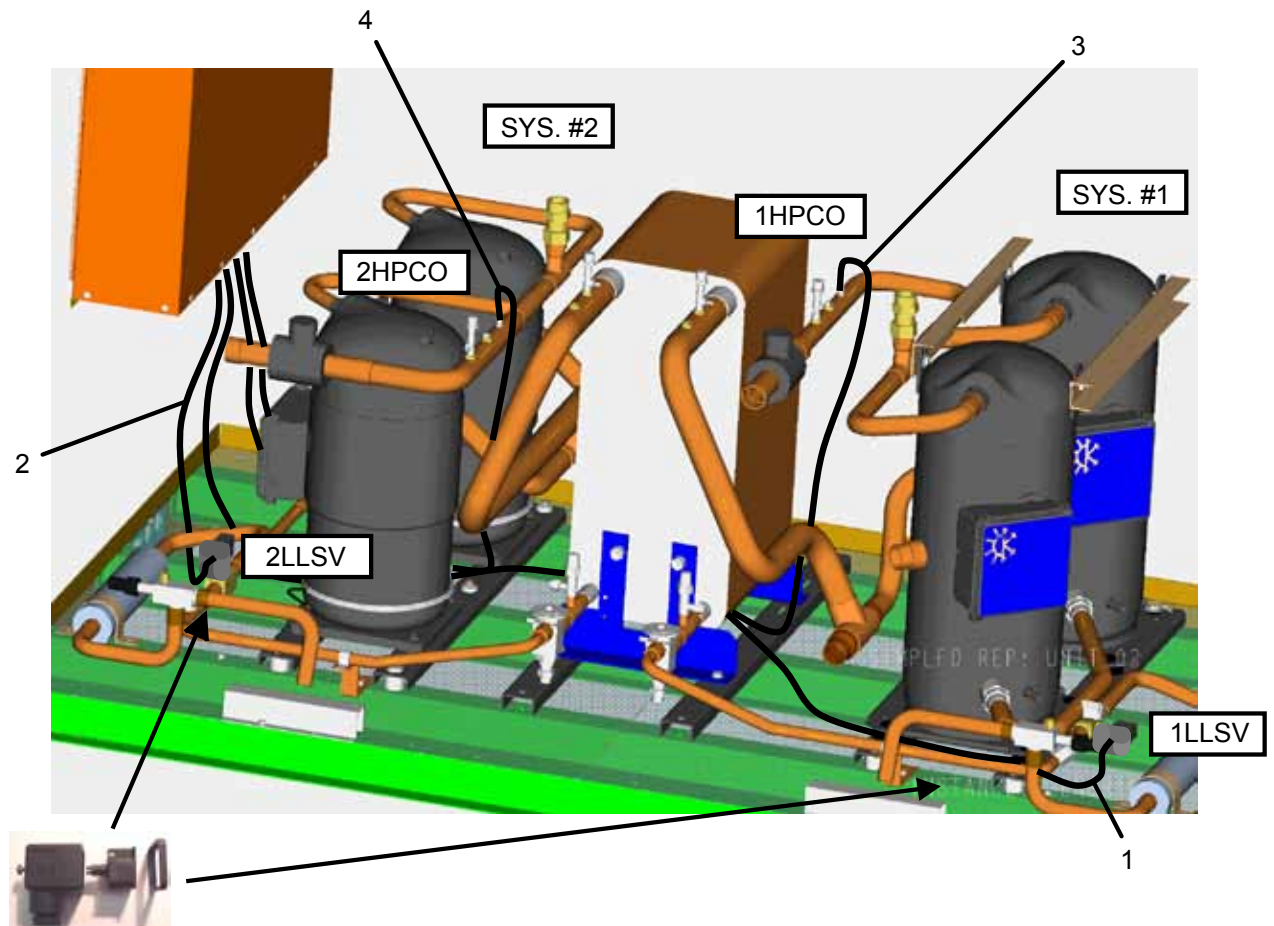

* Service Note: High Pressure Cut-Out Harness includes High Pressure Cut-Out Switch 025-41535-000



58363-004a

FIGURE 18 - CONTROL WIRING HARNESSSES

TABLE 18 - SENSOR HARNESS WIRING

PLUG DETAIL	PLUG AND PIN/P/N	PLUG "P" NUMBER	PLUG PIN NUMBER	WIRE COLOR	CABLE NUMBER	FUNCTION	HARNESS ASSEMBLY PART NUMBER	FIGURE
	Plug = 025-28384-000 Pin = 025-28386-000	P4	5	Red	S1SP	System #1 Suction Pressure	575-57126-313	19
			10	White				
			1	Black				
			2	Drain	S1DP	System #1 Discharge Pressure		
			7	Red				
			12	White				
	Plug = 025-28384-000 Pin = 025-28386-000	P7	8	Black	S2SP	System #2 Suction Pressure		
			9	Drain				
			5	Red			S2DP	
			10	White				
			1	Black				
						2	Drain	
7	Red							
12	White							
			8	Black				
			9	Drain				
			5	Red				

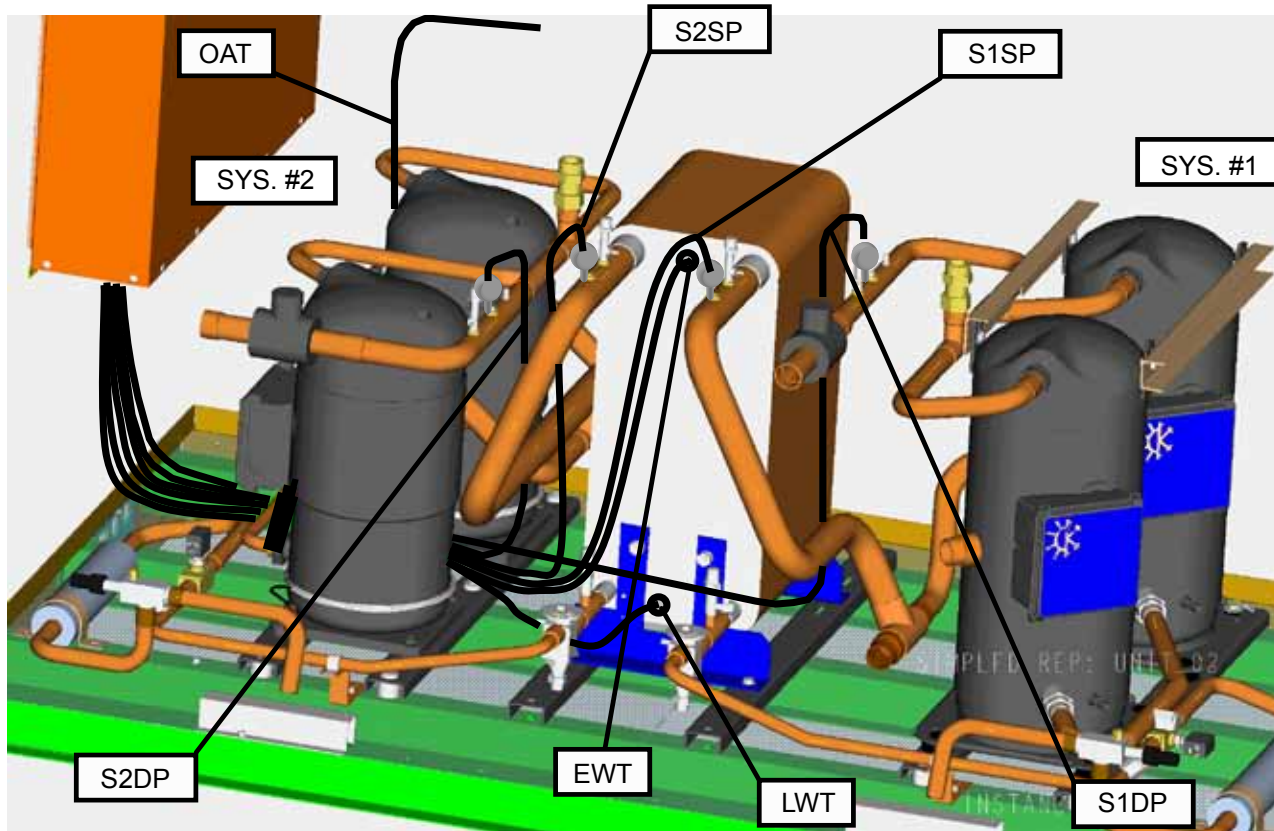

58363-005

FIGURE 19 - SENSOR WIRING HARNESES

TABLE 19 - TEMPERATURE SENSORS AND TRANSDUCERS

ITEM	QUANTITY	DESCRIPTION	MODELS	PART NUMBER	FIGURE
1 ^S	1	Sensor, Outside Air Temperature (Cable Included)	0019-0033	025-40273-008*	Not Shown
			0043-0052	025-40273-006*	
			0056-0066	025-40273-003*	
2 ^S	2	Sensor, Entering Water Temp. (Cable Included)	0019-0033	025-04273-002*	20
			0043-0052	025-04273-005*	
			0056-0066	025-04273-002*	
3 ^S	2	Sensor, Leaving Water Temp. (Cable Included)	0019-0033	025-04273-007*	20
			0043-0052	025-04273-004*	
			0056-0066	025-04273-001*	
4	-	Compound, Heat Conductive**	All	013-00898-000	
5 ^S	2	Transducer, Suction Pressure (0-400psi)	All	025-41756-002	
6 ^S	2	Transducer, Discharge Pressure (0-650psi)	All	025-41756-003	
7 ^S	2	Switch, High Pressure Cut-Out	All	025-41535-000	Not Shown

^S Recommended Spare Part

* **Note:** Sensor only = 025-29964-000.

** **Note:** Used with items 2 and 3.

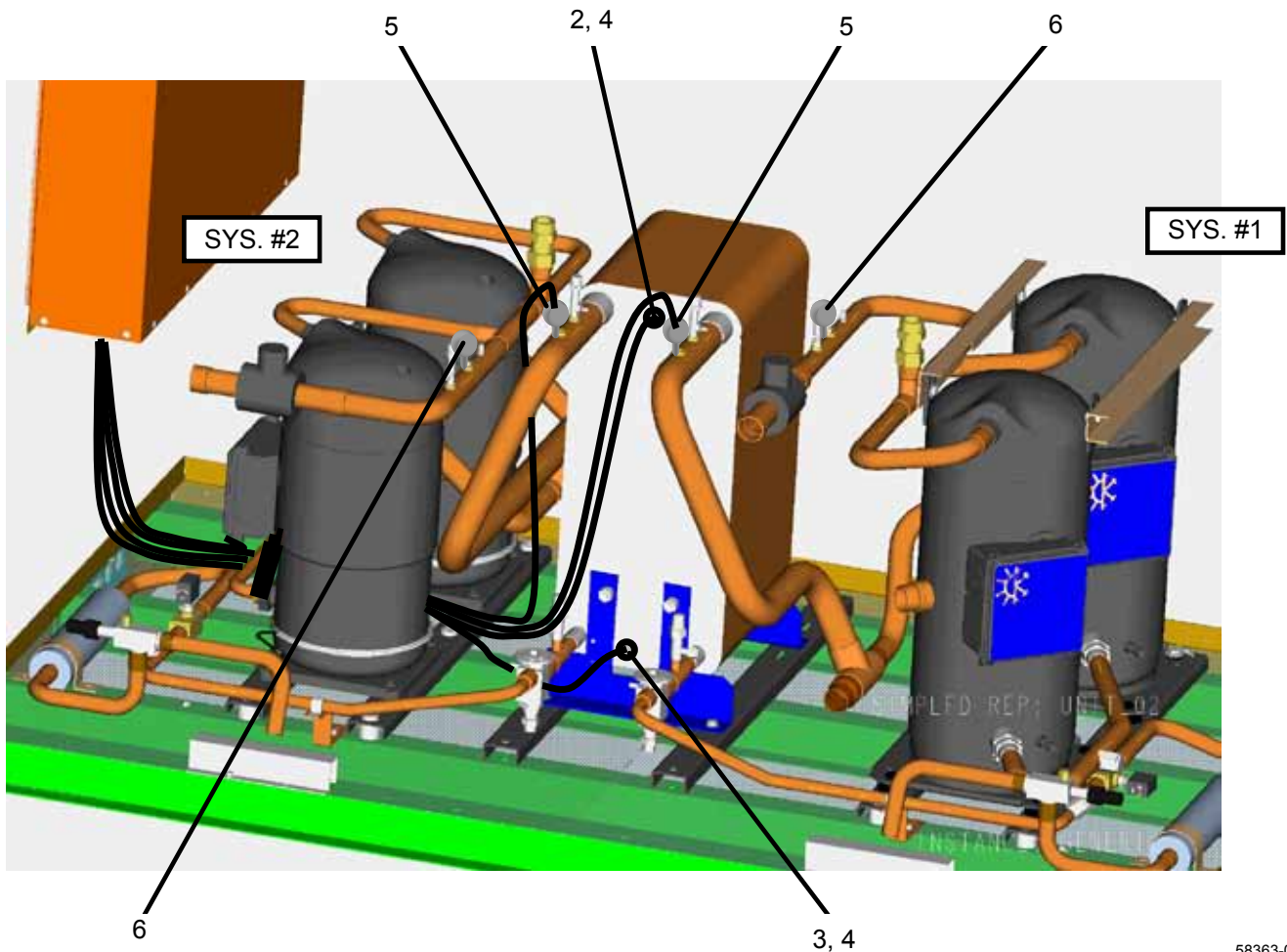

58363-005A

FIGURE 20 - TEMPERATURE SENSORS AND TRANSDUCERS

TABLE 20 - TRANSDUCER AND THERMISTOR WIRE HARNESS CONNECTORS - FIELD REPLACEMENT PARTS

ITEM	LOCATION	DESCRIPTION	PINS	PART NUMBER	FIGURE
1	Transducer	Plug Connector	3 Pin End	025-30463-001	21

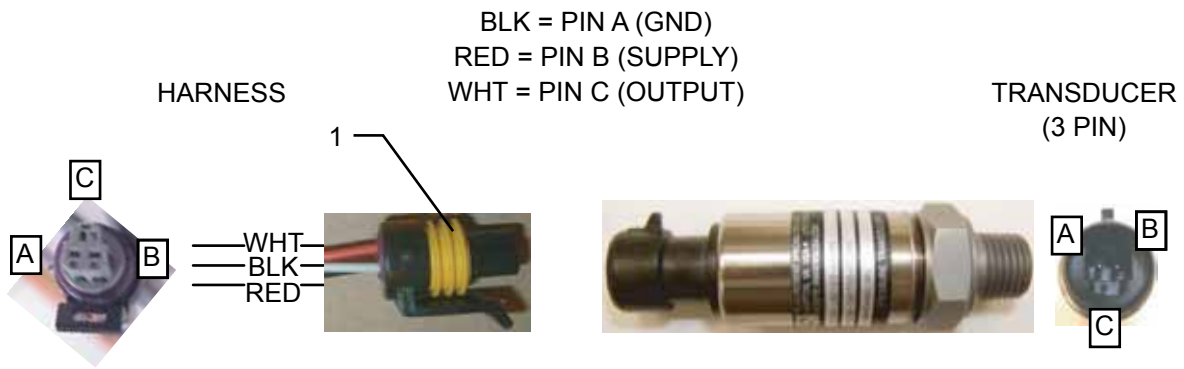

LD15732

FIGURE 21 - TRANSDUCER AND THERMISTOR WIRE HARNESS CONNECTORS - FIELD REPLACEMENT PART NUMBERS

SECTION 9 - ENCLOSURES

TABLE 21 - WIRE KIT OPTIONS

MODEL NUMBER	WIRE ENCLOSURE (FACTORY INSTALLED)	LOUVERED ENCLOSURE (FIELD INSTALLED)
YCAL0019	375-61114-000	575-65188-000
YCAL0022		
YCAL0028	375-61115-000	575-65189-000
YCAL0033		

Refer to Tables 22 And 23

TABLE 22 - WIRE ENCLOSURE PARTS

ITEM	DESCRIPTION	YCAL0019 and YCAL0022		YCAL0028 and YCAL0033		FIGURE
		375-61114-000	QUANTITY	375-61115-000	QUANTITY	
1	WIRE PANEL, SIDES	026-41826-010	2	026-41826-009	2	22
2	WIRE PANEL, REAR	026-41826-011		026-41826-008		

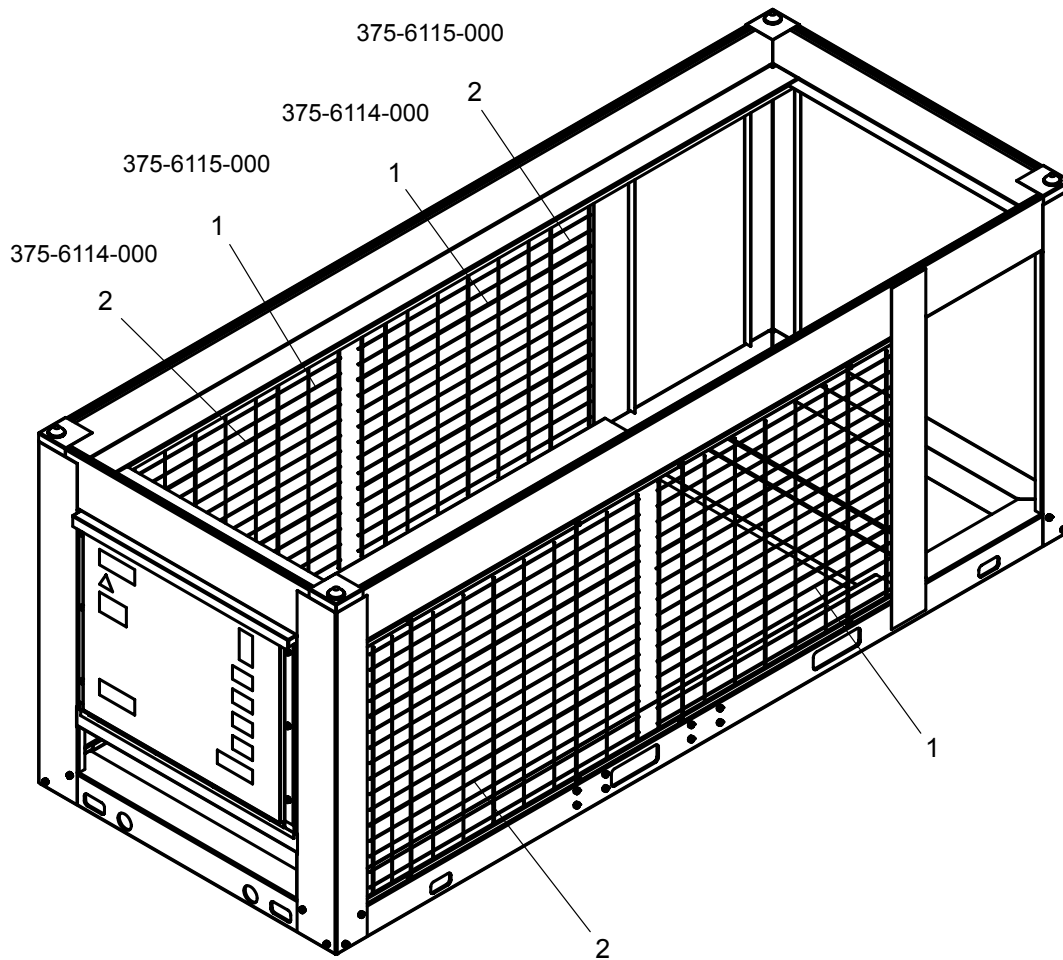

61114-000

FIGURE 22 - WIRE ENCLOSURE PARTS

TABLE 23 - LOUVERED ENCLOSURE PARTS

ITEM	DESCRIPTION	YCAL0019 AND YCAL0022		YCAL0028 AND YCAL0033		FIGURE
		575-65188-000	QUANTITY	575-65189-000	QUANTITY	
1	LOUVERED PANEL	075-60803-009	2	075-60803-010	2	23
2	LOUVERED PANEL	075-60803-008		075-60803-011		

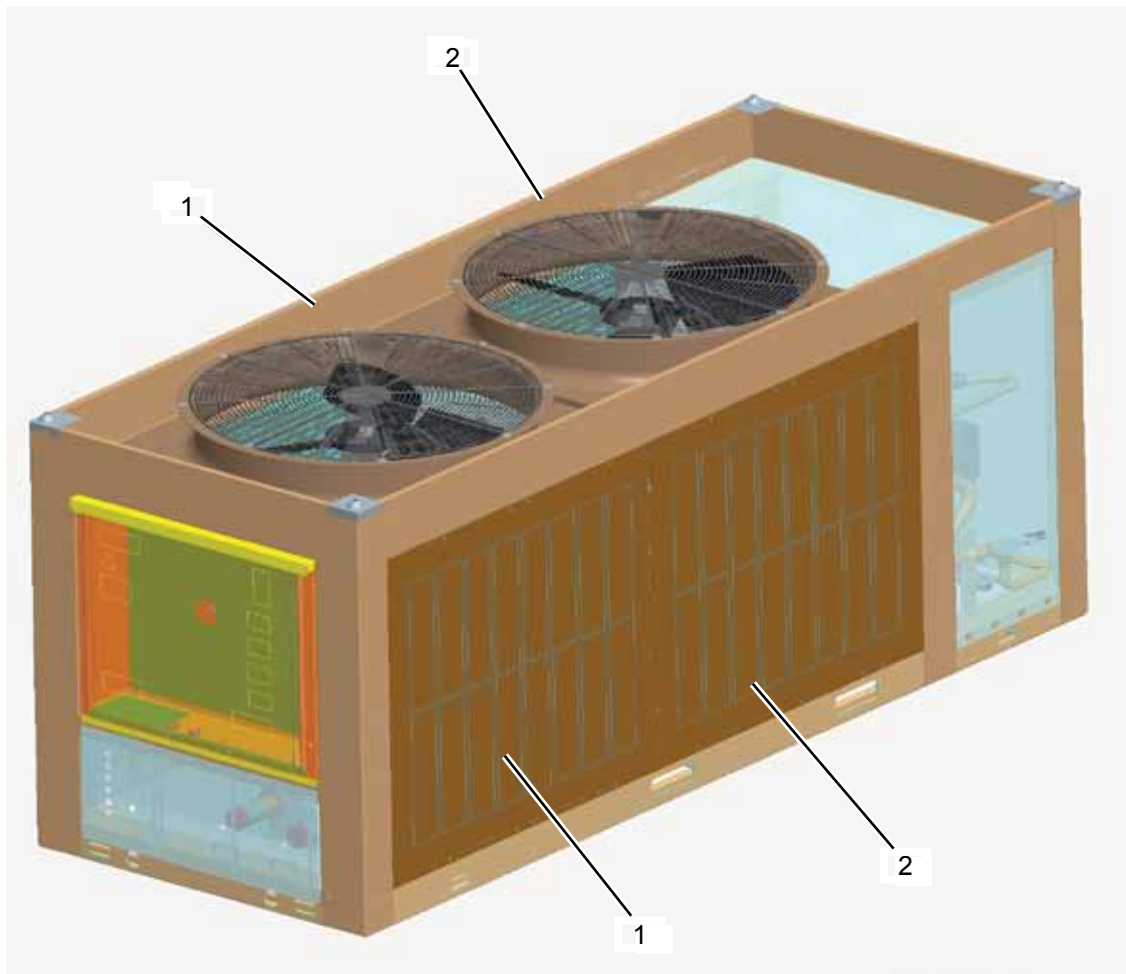

60803-001

FIGURE 23 - LOUVERED ENCLOSURE PARTS

TABLE 24 - ENCLOSURE KIT OPTIONS

MODEL NUMBER	WIRE ENCLOSURE (FACTORY INSTALLED)	LOUVERED ENCLOSURE (FIELD INSTALLED)
YCAL0043	375-59527-000	575-59445-000
YCAL0046		
YCAL0052	375-59526-000	575-59444-000
YCAL0056		
YCAL0066	375-59525-000	575-59443-000

Refer to Tables 25 and 26

TABLE 25 - WIRE ENCLOSURE PARTS

ITEM	DESCRIPTION	YCAL0043 AND YCAL0046		YCAL0052 AND YCAL0056		FIGURE
		375-59527-000	QUANTITY	375-59526-000	QUANTITY	
1	WIRE PANEL, SIDES	026-41826-005	4	026-41826-003	4	24
2	WIRE PANEL, REAR	026-41826-004	3	026-41826-002	3	

ITEM	DESCRIPTION	YCAL0066		FIGURE
		375-59525-000	QUANTITY	
1	WIRE PANEL, SIDES	026-41826-001	4	24
2	WIRE PANEL, REAR	026-41826-002	3	

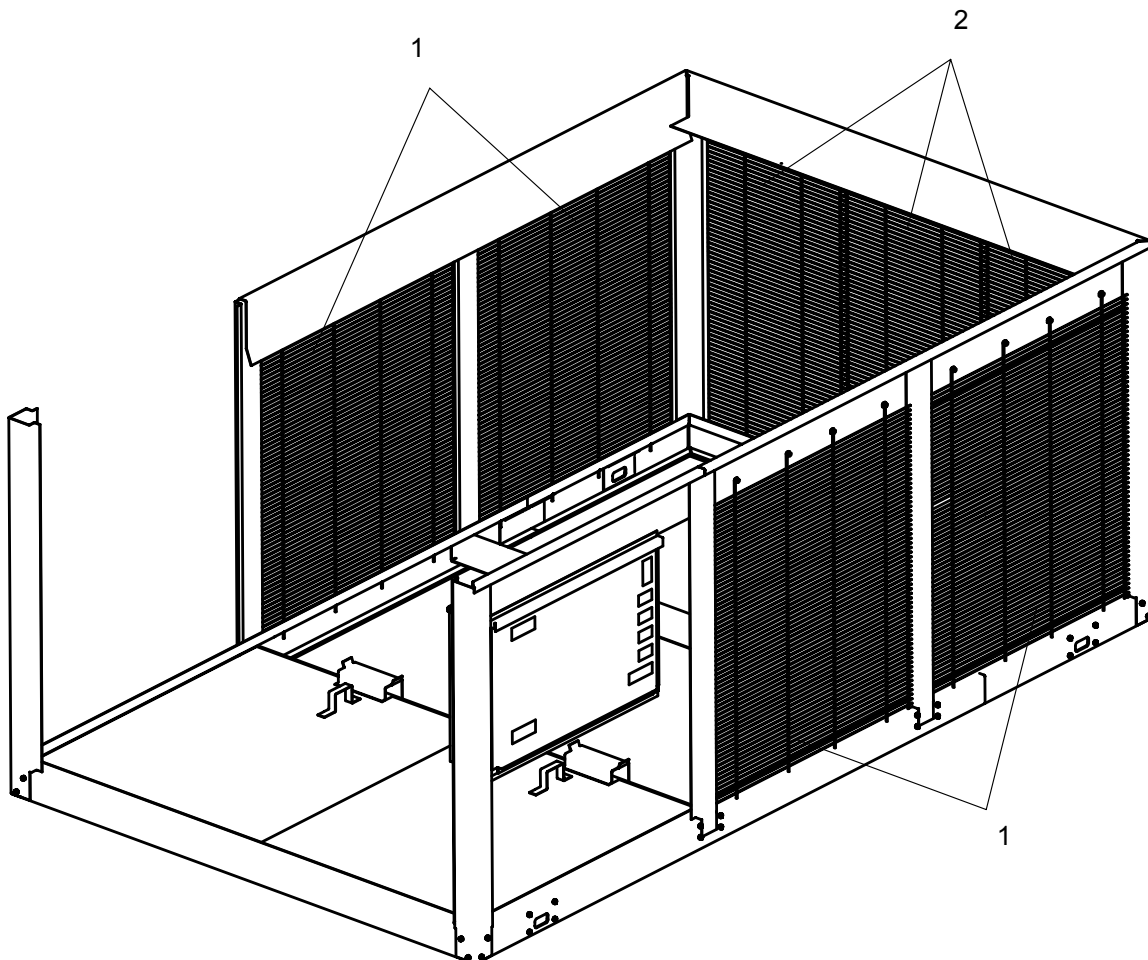

59525-000

FIGURE 24 - WIRE ENCLOSURE PARTS

TABLE 26 - LOUVERED ENCLOSURE PARTS

ITEM	DESCRIPTION	YCAL0043 and YCAL0046		YCAL0052 and YCAL0056		FIGURE
		575-59445-000	QUANTITY	575-59444-000	QUANTITY	
1	LOUVERED PANEL	075-60803-012	1	075-60803-005	1	25
2	LOUVERED PANEL	075-60803-002	4	075-60803-004	4	
3	LOUVERED PANEL	075-60803-003	1	075-60803-006	1	

ITEM	DESCRIPTION	YCAL0066		FIGURE
		575-59443-000	QUANTITY	
1	LOUVERED PANEL	075-60803-005	1	25
2	LOUVERED PANEL	075-60803-007	4	
3	LOUVERED PANEL	075-60803-006	1	

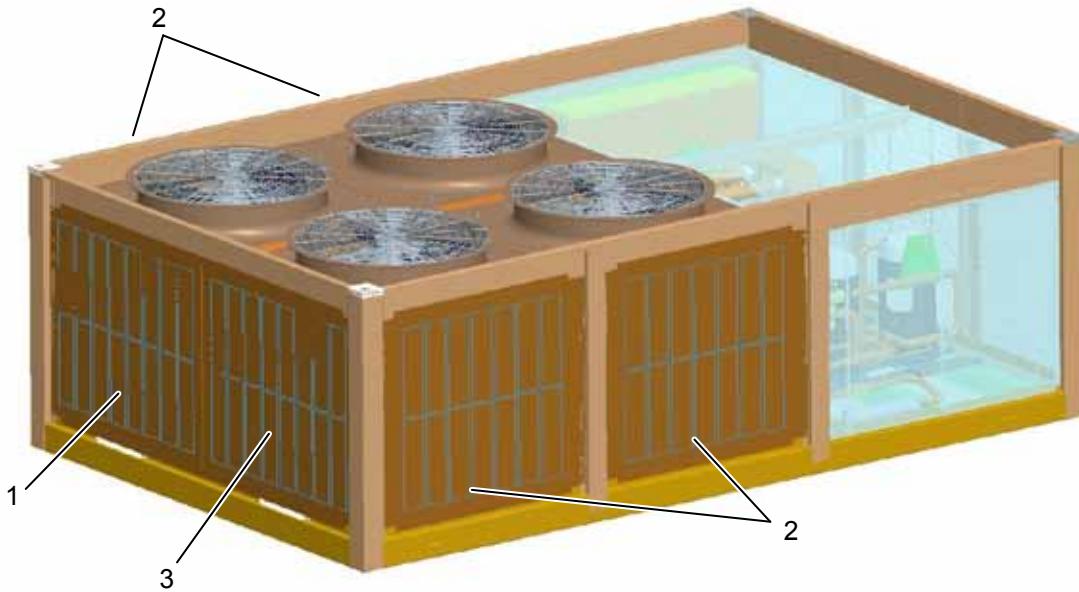

60803-000

FIGURE 25 - LOUVERED ENCLOSURE PARTS

SECTION 10 - CHILLER OPTIONS

TABLE 27 - VIBRATION ISOLATORS PART NUMBERS

ONE INCH DEFLECTION SPRING ISOLATOR CROSS REFERENCE FOR UNITS WITH ALL POINT LOADS LESS THAN 1404 LBS. (637 KG.)

WEIGHT RANGE (lbs.)	WEIGHT RANGE (kg.)	VENDOR PART NUMBER	COLOR	YORK PART NUMBER
239 to 384 lbs.	108 to 174 kg.	CIP-B-450	RED	029-24583-002
384 to 639 lbs.	174 to 290 kg.	CIP-B-750	WHITE	029-24583-003
639 to 851 lbs.	290 to 386 kg.	CIP-B-1000	BLUE	029-24583-004
851 to 1064 lbs.	386 to 483 kg.	CIP-B-1250	GRAY	029-24583-005
1064 to 1404 lbs.	483 to 637 kg.	CIP-B-1650	BLACK	029-24583-006

FOR UNITS WITH ANY POINT LOAD ABOVE 1404 LBS. (637 KG.)

WEIGHT RANGE (lbs.)	WEIGHT RANGE (kg.)	VENDOR PART NUMBER	COLOR	YORK PART NUMBER
Up to 851 lbs.	Up to 386 kg.	CIP-C-1000	BLACK	029-24583-007
851 to 1149 lbs.	386 to 521 kg.	CIP-C-1350	YELLOW	029-24583-008
1149 to 1489 lbs.	521 to 675 kg.	CIP-C-1750	BLACK	029-24583-009
1489 to 1786 lbs.	675 to 910 kg.	CIP-C-2100	YELLOW W/ RED	029-24583-010
1786 to 2028 lbs.	910 to 920 kg.	CIP-C-2385	YELLOW W/ GREEN	029-24583-011
2028 to 2254 lbs.	920 to 1022 kg.	CIP-C-2650	RED W/ RED	029-24583-012
2254 to 2936 lbs.	1022 to 1332 kg.	CIP-C-2935	RED W/ GREEN	029-24583-013

NEOPRENE ISOLATOR CROSS REFERENCE

WEIGHT RANGE (lbs.)	WEIGHT RANGE (kg.)	VENDOR PART NUMBER	COLOR	YORK PART NUMBER
Up to 751 lbs.	Up to 341 kg.	ND-C	YELLOW	029-24584-001
751 to 1651 lbs.	341 to 749 kg.	ND-D	YELLOW	029-24584-002
1651 to 3226 lbs.	749 to 1463 kg.	ND-DS	YELLOW	029-24584-004

TWO INCH DEFLECTION, SEISMIC SPRING ISOLATOR CROSS REFERENCE

WEIGHT RANGE (lbs.)	WEIGHT RANGE (kg.)	VENDOR PART NUMBER	COLOR	YORK PART NUMBER
Up to 358 lbs.	Up to 162 kg.	SLRS-2-C2-420	RED	029-24585-006
358 to 443 lbs.	162 to 201 kg.	SLRS-2-C2-520	WHITE	029-24585-007
443 to 582 lbs.	201 to 264 kg.	SLRS-2-C2-660	BLACK	029-24585-008
582 to 783 lbs.	264 to 335 kg.	SLRS-2-C2-920	BLUE	029-24585-009
783 to 1038 lbs.	335 to 471 kg.	SLRS-2-C2-1220	GREEN	029-24585-010
1038 to 1497 lbs.	471 to 679 kg.	SLRS-2-C2-1760	GRAY	029-24585-011
1497 to 2058 lbs.	679 to 933 kg.	SLRS-2-C2-2420	SILVER	029-24585-012
2058 to 2619 lbs.	933 to 1188 kg.	SLRS-2-C2-3080	GRAY W/ RED	029-24585-013
2619 to 3180 lbs.	1188 to 1442 kg.	SLRS-2-C2-3740	SILVER W/ RED	029-24585-014

TABLE 28 - FIELD INSTALLED OPTIONS KIT NUMBERS

MODEL NUMBER YCAL	HOT GAS BY-PASS SOLENOID VALVE W/ HARNESS * (1 CIRCUIT)	HOT GAS BY-PASS SOLENOID VALVE W/ HARNESS * (2 CIRCUITS)	BAS/EMS TEMPERATURE RESET / OFFSET	MICRO GATEWAY	CHICAGO CODE RELIEF VALVE	DIFFERENTIAL PRESSURE SWITCH		
MODEL	375-	375-	375-30914	371-04455	022-10682	025-30919		
0019	65191-700	N/A	-000	-010	-001	-000		
0022								
0028	65191-500							
0033								
0043	59523-800	59523-820						
0046								
0052							59523-600	59523-620
0056							59523-700	59523-720
0066			59523-500	59523-520				

*Note: Hot Gas By-Pass Solenoid Valve Only: 025-34133-000

MODEL NUMBER YCAL	STANDARD 150# VICTAULIC FLANGE	OPTIONAL 300# VICTAULIC FLANGE	STANDARD 150# FLOW SWITCH	OPTIONAL 300# FLOW SWITCH	MOTOR CURRENT MODULE KIT	OPTIVIEW REMOTE CONTROL PANEL	SOUND BLANKET KIT			
MODEL	023-	023-	024-26116	024-12144	371-04101	371-02750	310-06507			
0019	22869-000	22868-000	-000	-000	-001	-101	-717			
0022							-736			
0028							-720			
0033							-710			
0043	22554-000	22553-000			-000		-000	-000	-101	-723
0046										-714
0052										-710
0056										-723
0066							-714			

TABLE 29 - CONTROL TRANSFORMER KIT

MODEL NUMBERS	VOLTAGE	DESCRIPTION	PART NUMBER
YCAL0019, YCAL0022, 0028 and YCAL0033	-17	KIT, CONTROL TRANSFORMER	375-65193-101
	-28		375-65193-102
	-40		375-65193-103
	-46		375-65193-104
	-50		375-65193-105
	-58		375-65193-106
YCAL0043, YCAL0046, 0052, 0056 and YCAL0066	-17	KIT, CONTROL TRANSFORMER	375-59641-101
	-28		375-59641-102
	-40		375-59641-103
	-46		375-59641-104
	-50		375-59641-105
	-58		375-59641-106

TABLE 30 - OPTIVIEW REMOTE CONTROL CENTER PARTS

371-02750-101

ITEM NUMBER	QUANTITY	DESCRIPTION	PART NUMBER	FIGURE
1	1	MICROPROCESSOR BOARD	031-01730-002	26
2	1	POWER SUPPLY ASSEMBLY	371-02750-411	
3	1	KEYPAD	024-30974-001	Not Shown
4	1	TERMINAL BLOCK	025-35120-000	26
5	1	DISPLAY	331-02053-000	Not Shown
6	1	RIBBON CABLE	031-02056-000	26
7	1	WIRE CABLE	571-02750-421	
8	8	LAN TRANSIENT PROTECTION MODULE	031-01586-000	
9	1	COVER, REMOTE CONTROL	371-02750-311	
10	1	BASE, REMOTE CONTROL	071-02485-320	
11	1	EPROM	031-01796-002	
12	1	FLASH MEMORY CARD	031-02057-001	

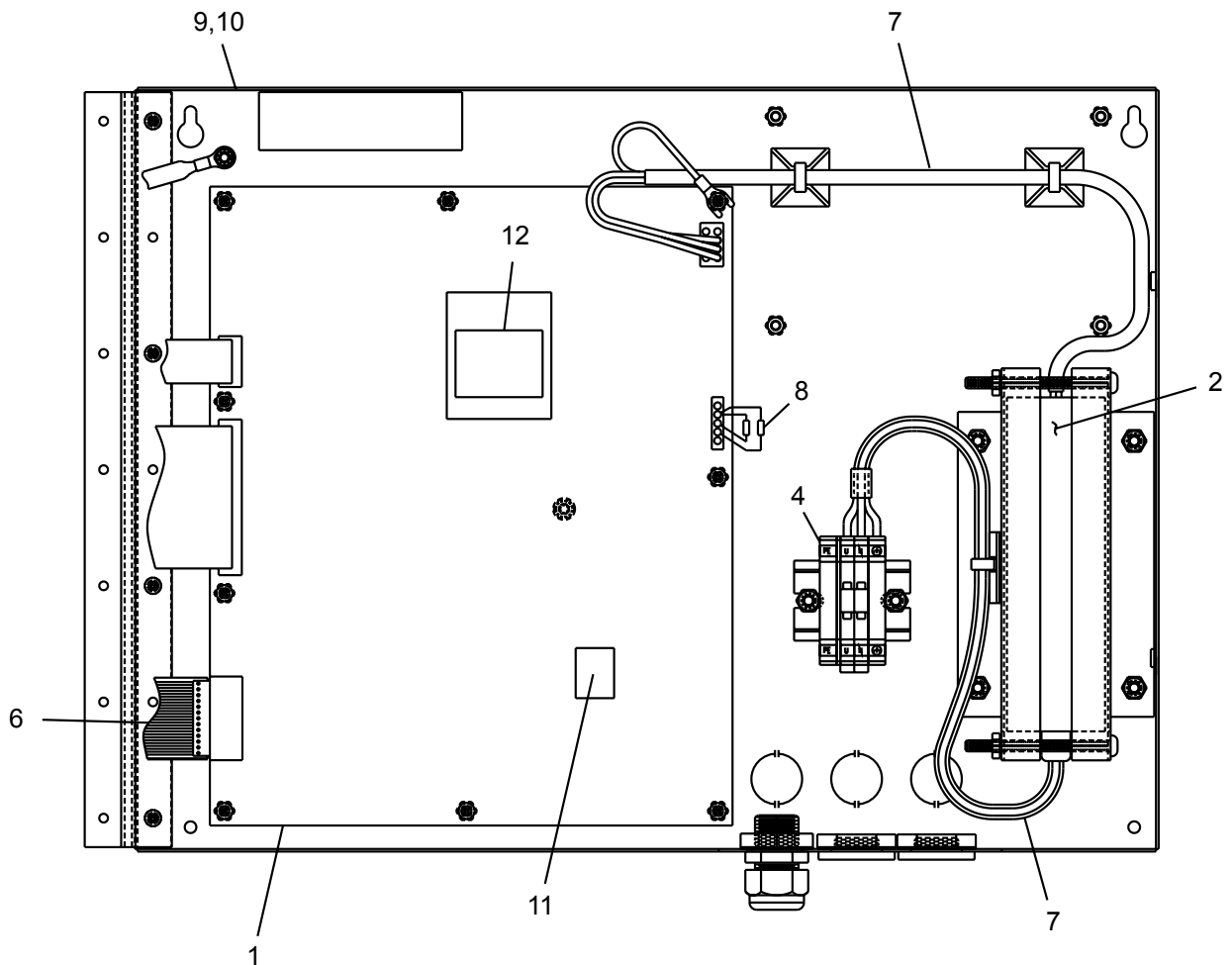

02750-3A

FIGURE 26 - OPTIVIEW REMOTE CONTROL CENTER PARTS

TABLE 31 - REMOTE RESET WIRING

ITEM	QUANTITY	DESCRIPTION	PART NUMBER	FIGURE
8	2	CONT SOC AWG WIRE SIZE 20	025-19674-000	27
9	2	TERMINAL PUSH ON STRAIGHT	025-06642-000	
10	4	TUBING HEAT SHRINKABLE 1/8" I.D.	025-29632-000	
11	1	HGS CONNECTOR ELECTRICAL PLUG	025-32564-000*	
12	1	CONNECTOR EDGE, 15 POSITION, 0.125	025-17594-000	

TABLE 32 - REMOTE TEMPERATURE RESET KIT COMPONENTS

375-90914-000

ITEM	QUANTITY	DESCRIPTION	PART NUMBER	FIGURE
1	1	CONTROL, REMOTE CURRENT/TEMPERATURE	031-00814-000	27
2	1	BRACKET, REMOTE CURRENT/ TEMPERATURE RESET	371-01232-361	
3	1	TRACK, SNAP	071-01232-363	
4	1	WIRING, REMOTE CURRENT/ TEMPERATURE RESET	571-02492-231*	
5	2	SCREW, MACHINE PAN HEAD #4	021-17594-000	
6	2	NUT, HEX #4 - 40 UNC-2B	021-10056-000	
7	2	LOCKWASHER, HELICAL SPRING #4 REGULAR	021-17576-000	

* Refer to Table 31

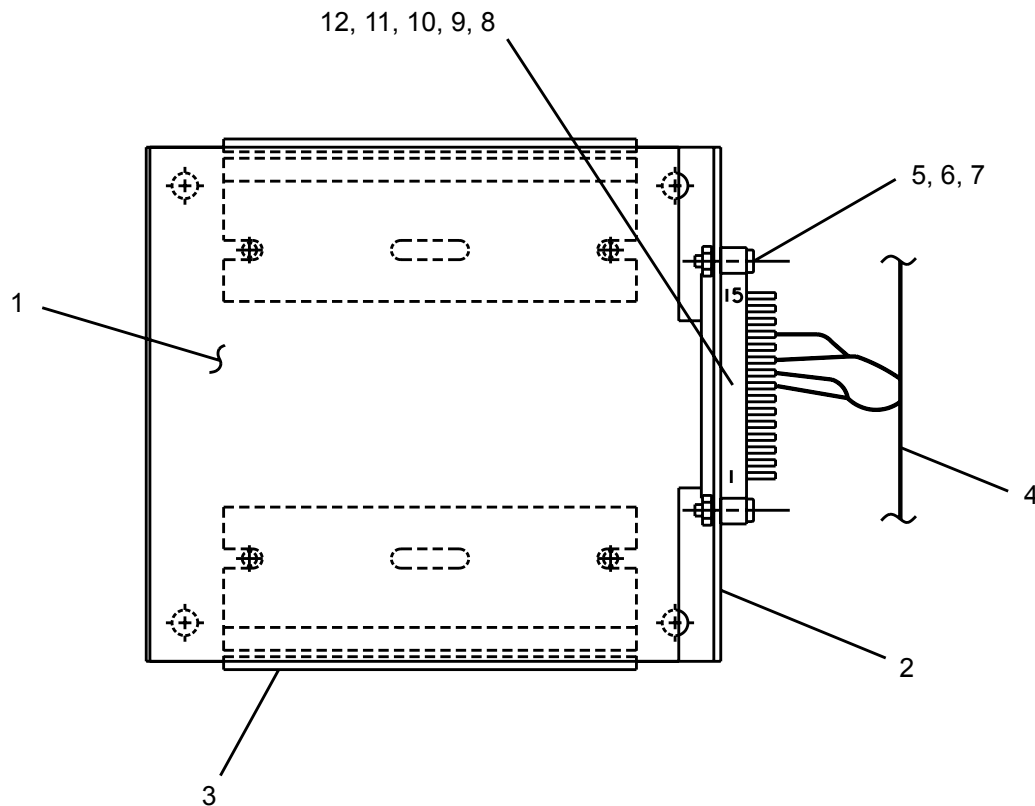

LD05256

FIGURE 27 - REMOTE TEMPERATURE RESET KIT COMPONENTS

SECTION 11 - SPARE PARTS

TABLE 33 - RECOMMENDED SPARE PARTS - YCAL STYLE 'E' CHILLERS

DESCRIPTION	MODEL NUMBER YCAL	VOLTAGE CODE	PART NUMBER	REFERENCE LOCATION
Fan Motor (Standard)	0019 & 0022	-17 & -28	024-35427-002	Figure 8 on page 17, Item 1
		-40	024-35427-004	
		-46 & -50	024-35427-001	
		-58	024-35427-003	
Fan Motor (Standard)	0028, 0033, 0043, 0046, 0052, 0056 & 0066	-17	024-27322-103	Figure 9 on page 18, Item 1
		-28	024-27322-106	
		-40	024-27322-104	
		-46 & -50	024-27322-107	
		-58	024-27322-102	
Fan Blade (Standard)	0019 & 0022	All	026-43008-000	Figure 8 on page 17, Item 2
	0043, 0046 & 0052		026-41592-000	Figure 9 on page 18, Item 2
	0028, 0033, 0056 & 0066		026-41594-000	
Thermal Expansion Valve	All	All	025-40900-001	Table 10 on page 19, Item 1
			025-40900-002	
			025-40900-003	
			025-40900-006	
			025-40900-007	
Valve, Liquid Line	All	All	022-11306-000	Table 10 on page 19, Item 4
			022-10022-000	
Oil, Compressor - (6) 1 Gallon	All	All	011-00948-000	Table 11 on page 27, Oil
Oil, Compressor - 5 Gallon			011-00949-000	
Sensor, Outside Air	0019-0033	All	025-40273-008	Table 19 on page 53, Item 1
	0043-0052		025-40273-006	
	0056-0066	All	025-40273-003	
Sensor, Entering Water Temperature	0019-0033	All	025-40273-002	Table 19 on page 53, Item 2
	0043-0052		025-40273-005	
	0056-0066		025-40273-002	
Sensor, Leaving Water Temperature	0019-0033	All	025-40273-007	Table 19 on page 53, Item 3
	0043-0052		025-40273-004	
	0056-0066		025-40273-001	
Transducer, Suction Pressure	All	All	025-41756-002	Table 19 on page 53, Item 5
Transducer, Discharge Pressure	All	All	025-41756-003	Table 19 on page 53, Item 6
Switch, High Pressure Cut-Out	All	All	025-41535-000	Table 19 on page 53, Item 7

All parts should be purchased from your local JCI/
YORK Sales and Service Center.



BY JOHNSON CONTROLS

P.O. Box 1592, York, Pennsylvania USA 17405-1592
Copyright © by Johnson Controls 2011

Tele. 800-861-1001
www.york.com

Subject to change without notice. Printed in USA
ALL RIGHTS RESERVED

Form 150.67-RP1 (511)
Issue Date: May 18, 2011
Supersedes: 150.67-RP1 (310)