



AIR-COOLED LIQUID CHILLERS HERMETIC SCROLL

INSTALLATION, OPERATION, MAINTENANCE

Supersedes 150.67-NM1 (312)

Form 150.67-NM1 (1016)

035-21456-000

YCAL0019, 0022, 0028, 0033, 0043, 0046, 0052, 0056, 0066 AIR-COOLED SCROLL CHILLERS STYLE E (60 HZ) 15-65 TON



DUAL CIRCUIT

LD10950



SINGLE CIRCUIT

R-410A



Issue Date:
October 7, 2016



IMPORTANT!

READ BEFORE PROCEEDING!

GENERAL SAFETY GUIDELINES

This equipment is a relatively complicated apparatus. During rigging, installation, operation, maintenance, or service, individuals may be exposed to certain components or conditions including, but not limited to: heavy objects, refrigerants, materials under pressure, rotating components, and both high and low voltage. Each of these items has the potential, if misused or handled improperly, to cause bodily injury or death. It is the obligation and responsibility of rigging, installation, and operating/service personnel to identify and recognize these inherent hazards, protect themselves, and proceed safely in completing their tasks. Failure to comply with any of these requirements could result in serious damage to the equipment and the property in

which it is situated, as well as severe personal injury or death to themselves and people at the site.

This document is intended for use by owner-authorized rigging, installation, and operating/service personnel. It is expected that these individuals possess independent training that will enable them to perform their assigned tasks properly and safely. It is essential that, prior to performing any task on this equipment, this individual shall have read and understood the on-product labels, this document and any referenced materials. This individual shall also be familiar with and comply with all applicable industry and governmental standards and regulations pertaining to the task in question.

SAFETY SYMBOLS

The following symbols are used in this document to alert the reader to specific situations:



Indicates a possible hazardous situation which will result in death or serious injury if proper care is not taken.

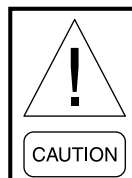

Identifies a hazard which could lead to damage to the machine, damage to other equipment and/or environmental pollution if proper care is not taken or instructions and are not followed.



Indicates a potentially hazardous situation which will result in possible injuries or damage to equipment if proper care is not taken.

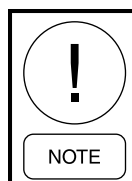

Highlights additional information useful to the technician in completing the work being performed properly.



External wiring, unless specified as an optional connection in the manufacturer's product line, is not to be connected inside the control cabinet. Devices such as relays, switches, transducers and controls and any external wiring must not be installed inside the micro panel. All wiring must be in accordance with Johnson Controls' published specifications and must be performed only by a qualified electrician. Johnson Controls will NOT be responsible for damage/problems resulting from improper connections to the controls or application of improper control signals. Failure to follow this warning will void the manufacturer's warranty and cause serious damage to property or personal injury.

CHANGEABILITY OF THIS DOCUMENT

In complying with Johnson Controls' policy for continuous product improvement, the information contained in this document is subject to change without notice. Johnson Controls makes no commitment to update or provide current information automatically to the manual or product owner. Updated manuals, if applicable, can be obtained by contacting the nearest Johnson Controls Service office or accessing the Johnson Controls QuickLIT website at <http://cgproducts.johnsoncontrols.com>.

It is the responsibility of rigging, lifting, and operating/service personnel to verify the applicability of these documents to the equipment. If there is any question

regarding the applicability of these documents, rigging, lifting, and operating/service personnel should verify whether the equipment has been modified and if current literature is available from the owner of the equipment prior to performing any work on the chiller.

CHANGE BARS

Revisions made to this document are indicated with a line along the left or right hand column in the area the revision was made. These revisions are to technical information and any other changes in spelling, grammar or formatting are not included.

SINGLE CIRCUIT AND DUAL CIRCUIT MODELS

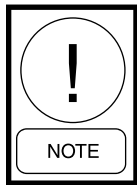

This manual contains installation, operation and maintenance instructions for both single and dual refrigerant circuit models. If your unit is a single circuit model (YCAL0019-0033), disregard references to "System 2" which may appear in this manual. Any references to Sys 2 are applicable to YCAL0043-0066 models.

THIS PAGE INTENTIONALLY LEFT BLANK

TABLE OF CONTENTS

SECTION 1 – GENERAL CHILLER INFORMATION and SAFETY	15
INTRODUCTION	15
WARRANTY	15
SAFETY.....	15
Standards for Safety.....	15
Responsibility for Safety.....	16
ABOUT THIS MANUAL	16
MISUSE OF EQUIPMENT	16
Suitability for Application	16
Structural Support	16
Mechanical Strength	16
General Access	16
Pressure Systems	16
Electrical.....	17
Rotating Parts.....	17
Sharp Edges.....	17
Refrigerants and Oils.....	17
High Temperature and Pressure Cleaning	17
Emergency Shutdown	17
SECTION 2 – PRODUCT DESCRIPTION	19
INTRODUCTION.....	19
GENERAL SYSTEM DESCRIPTION	19
Compressors	19
Evaporator (Heat Exchanger).....	19
Condenser.....	20
Coils.....	20
Low Sound Fans.....	20
Motors.....	20
MILLENNIUM CONTROL CENTER.....	20
Display/Print	20
Entry	20
Setpoints	20
Unit.....	20
Unit On/Off Switch.....	21
COMMUNICATIONS	21
POWER PANEL	21
ACCESSORIES AND OPTIONS	22
Power Options.....	22
Compressor Power Connection.....	22
Single-Point Supply Terminal Block	22
Single-Point Non-Fused Disconnect Switch	22
Single-Point Circuit Breaker.....	22
Control Transformer.....	22
Power Factor Correction Capacitors	22
Control Options	22
Ambient Kit (Low).....	22
Ambient Kit (High).....	22
Building Automation System Interface	22
Language LCD And Keypad Display.....	22
Discharge Pressure Transducers And Readout Capability	22
Suction Pressure Transducers.....	23
Motor Current Module	23
Multi-Unit Sequencing.....	23

TABLE OF CONTENTS (CONT'D)

Compressor, Piping, Evaporator Options	23
Low Temperature Brine	23
Chicago Code Relief Valves	23
Service Isolation Valve	23
Hot Gas By-Pass	23
Heat Exchanger 300 PSIG (21 BARG) DWP Waterside	23
Flanges (ANSI/AWWA C-606 Couplings Type)	23
Flow Switch	23
150 PSIG (10.5 BARG) DWP	23
300 PSIG (21 BARG) DWP	23
Differential Pressure Switch	23
Condenser And Cabinet Options	23
Pre-Coated Fin Condenser Coils	23
Post-Coated Dipped Condenser Coils	24
Copper Fin Condenser Coils	24
Enclosure Panels (Unit)	24
Louvered Panels (Full Unit)	24
Sound Reduction / Attenuation Options	24
Vibration Isolators	24
UNIT COMPONENTS YCAL0019 - 0033	25
CONTROL - POWER PANEL COMPONENTS YCAL0019-0033	26
UNIT COMPONENTS - YCAL0043 – 0066	27
CONTROL / POWER PANEL COMPONENTS - YCAL0043 – 0066	28
PRODUCT IDENTIFICATION NUMBER (PIN)	29
BASIC UNIT NOMENCLATURE	29
REFRIGERANT FLOW DIAGRAM	34
SECTION 3 – HANDLING AND STORAGE	35
DELIVERY AND STORAGE	35
INSPECTION	35
MOVING THE CHILLER (YCAL0043 – 0066 DUAL SYSTEM ONLY)	35
Lifting Weights	35
MOVING THE CHILLER (YCAL0019 – 0033 SINGLE CIRCUIT ONLY)	35
UNIT RIGGING	36
Lifting Weights	36
SECTION 4 – INSTALLATION	39
INSTALLATION CHECKLIST	39
HANDLING	39
INSPECTION	39
LOCATION AND CLEARANCES	39
Ground Level Locations	39
Rooftop Locations	40
Noise Sensitive Locations	40
SPRING ISOLATORS (OPTIONAL)	40
COMPRESSOR MOUNTING	40
REMOTE COOLER OPTION	40
CHILLED LIQUID PIPING	40
PIPEWORK ARRANGEMENT	41
DUCT WORK CONNECTION	41
General Requirements	41
WIRING	41
Field Wiring	41
Evaporator Pump Start Contacts	42
System Run Contacts	42

TABLE OF CONTENTS (CONT'D)

Alarm Status Contacts.....	42
Remote Start/Stop Contacts.....	42
Remote Emergency Cutoff.....	42
Remote Temp Reset Input.....	42
Load Limit Input.....	42
Flow Switch Input.....	42
COMPRESSOR HEATERS.....	42
RELIEF VALVES.....	43
HIGH PRESSURE CUTOUT.....	43
CONTROL WIRING.....	45
SECTION 5 – TECHNICAL DATA.....	47
OPERATIONAL LIMITATIONS (ENGLISH).....	47
Voltage Limitations.....	47
OPERATIONAL LIMITATIONS (SI).....	50
Voltage Limitations.....	50
PHYSICAL DATA (ENGLISH).....	53
ELECTRICAL DATA (ENGLISH).....	54
ELECTRICAL NOTES AND LEGEND.....	59
CONTROL WIRING DIAGRAMS.....	60
POWER OPTIONS CONNECTION DIAGRAMS.....	72
CONNECTION WIRING DIAGRAMS.....	84
DIMENSIONS (ENGLISH).....	96
TECHNICAL DATA – CLEARANCES.....	132
ISOLATORS.....	133
General.....	133
ISOLATOR LOCATIONS.....	133
Weight Distribution and Isolator Mounting Positions YCAL0019 – 0033 (Without Pump Package Option).....	133
General.....	135
WEIGHT DISTRIBUTION AND ISOLATOR MOUNTING POSITIONS YCAL0043 – 0066.....	135
ISOLATOR DETAILS - UNITS SHIPPED ON OR AFTER JUNE 15, 2008.....	136
ISOLATOR DETAILS - UNITS SHIPPED BEFORE JUNE 15, 2008.....	142
SECTION 6 – COMMISSIONING.....	147
COMMISSIONING.....	147
PREPARATION – POWER OFF.....	147
Inspection.....	147
Refrigerant Charge.....	147
Service and Oil Line Valves.....	147
Compressor Oil.....	147
Fans.....	147
Isolation / Protection.....	147
Control Panel.....	147
Power Connections.....	147
Grounding.....	147
Supply Voltage.....	148
PREPARATION – POWER ON.....	148
Switch Settings.....	148
Compressor Heaters.....	148
Water System.....	148
Flow Switch.....	148
Temperature Sensor(s).....	148
EQUIPMENT START-UP CHECKLIST.....	149

TABLE OF CONTENTS (CONT'D)

- Checking The System Prior To Initial Start 149
 - Unit Checks..... 149
 - Compressor Heaters 149
 - Panel Checks 149
- CHECKING SUPERHEAT AND SUBCOOLING 150
- LEAK CHECKING 151
- UNIT OPERATING SEQUENCE 152
- SECTION 7 – UNIT CONTROLS 153
 - INTRODUCTION..... 153
 - IPU II and I/O Boards 153
 - Unit Switch 154
 - Display..... 154
 - Keypad 154
 - Battery Back-up..... 154
 - Transformer 154
 - Single System Select and Programming # of Compressors 154
 - STATUS KEY..... 155
 - Unit Status..... 155
 - General Status Messages 155
 - Fault Safety Status Messages..... 156
 - System Safeties 157
 - Unit Safeties..... 158
 - Unit Warning..... 158
 - Status Key Messages..... 160
 - DISPLAY/PRINT KEYS 161
 - Oper Data Key..... 161
 - Oper Data Quick Reference List 164
 - Print Key..... 164
 - Operating Data Printout..... 164
 - History Printout..... 165
 - History Displays..... 166
 - Software Version 168
 - ENTRY KEYS..... 169
 - Up and Down Arrow Keys 169
 - Enter/Adv Key 169
 - SETPOINTS KEYS 170
 - Cooling Setpoints 170
 - Leaving Chilled Liquid Control..... 170
 - Return Chilled Liquid Control 171
 - Remote Setpoint Control 171
 - SCHEDULE/ADVANCE DAY KEY..... 172
 - PROGRAM KEY..... 173
 - System Trip Volts..... 175
 - Unit Trip Volts 175
 - UNIT KEYS 177
 - Options Key..... 177
 - Option 1 – Language 177
 - Option 2 – System Switches: (two system units only) 177
 - Option 3 – Chilled Liquid Cooling Type:..... 177
 - Option 4 – Ambient Control Type 178
 - Option 5 – Local/Remote Control Type..... 178
 - Option 6 – Unit Control Mode 178
 - Option 7 – Display Units 178

TABLE OF CONTENTS (CONT'D)

Option 8 – Lead/Lag Type	178
Option 9 – Condenser Fan Control Mode	179
Option 10 – Manual Override Mode	179
Option 11 – Current Feedback Options Installed:	179
Option 12 – Power Fail Restart	179
Option 13 – Soft Start Enable/Disable	179
Option 14 – Unit Type	179
Option 15 – Refrigerant Type	180
Option 16 – Expansion Valve Type	180
Option 17 – Flash Card Update	180
Option 18 – Remote Temperature Reset	180
Option 19 – Pump Control	181
Option 20 – Pump Selection	181
CLOCK	181
SECTION 8 – UNIT OPERATION	183
CAPACITY CONTROL	183
SUCTION PRESSURE LIMIT CONTROLS	183
DISCHARGE PRESSURE LIMIT CONTROLS	183
LEAVING CHILLED LIQUID CONTROL	183
LEAVING CHILLED LIQUID CONTROL OVERRIDE TO REDUCE CYCLING	184
LEAVING CHILLED LIQUID SYSTEM LEAD/LAG AND COMPRESSOR SEQUENCING	184
RETURN CHILLED LIQUID CONTROL	185
RETURN CHILLED LIQUID SYSTEM LEAD/LAG AND COMPRESSOR SEQUENCING	185
ANTI-RECYCLE TIMER	186
ANTI-COINCIDENCE TIMER	186
EVAPORATOR PUMP CONTROL and YORK HYDRO KIT PUMP CONTROL	187
EVAPORATOR HEATER CONTROL	187
PUMPDOWN CONTROL	187
STANDARD CONDENSER FAN CONTROL	187
YCAL0019-0028 LOW AMBIENT FAN CONTROL OPTION	190
General	190
Potentiometer Configuration	190
Wiring	191
PROGRAMMING - YCAL0019 – 0028	192
YCAL0033 Low Ambient Fan Control Option	192
General	192
CONFIGURATION (JUMPERS AND POTENTIOMETERS)	193
Wiring	194
YCAL0033 PROGRAMMING	195
YCAL0043 – 0066 LOW AMBIENT FAN CONTROL OPTION	196
General	196
CONFIGURATION (JUMPERS AND POTENTIOMETERS)	197
Wiring	197
PROGRAMMING	198
LOAD LIMITING	200
COMPRESSOR RUN STATUS	200
ALARM STATUS	200
BAS/EMS TEMPERATURE RESET USING A VOLTAGE OR CURRENT SIGNAL	200
SECTION 9 – SERVICE AND TROUBLESHOOTING	203
CLEARING HISTORY BUFFERS	203
SERVICE MODE	203
SERVICE MODE – OUTPUTS	203

TABLE OF CONTENTS (CONT'D)

SERVICE MODE – CHILLER CONFIGURATION	204
SERVICE MODE – ANALOG and DIGITAL INPUTS	204
CONTROL INPUTS/OUTPUTS.....	205
CHECKING INPUTS AND OUTPUTS.....	207
Digital Inputs.....	207
Analog Inputs – Temperature	207
Outside Air Sensor	207
Liquid and Refrigerant Sensor Test Points	208
Entering Chilled Liquid Sensor.....	208
Leaving Chilled Liquid Temperature Sensor	208
Analog Inputs – Pressure	209
System 1 Discharge Transducer.....	209
System 2 Discharge Transducer.....	209
System 1 Suction Transducer	210
System 2 Suction Transducer	210
Digital Outputs.....	210
Parts.....	211
Assembly and Wiring.....	211
Obtaining a Printout.....	211
SECTION 10 – MAINTENANCE	215
IMPORTANT.....	215
COMPRESSORS	215
Oil Level Check	215
Oil Analysis.....	215
CONDENSER FAN MOTORS.....	215
CONDENSER COILS.....	215
OPERATING PARAMETERS	215
ON-BOARD BATTERY BACK-UP	215
PLATE AND FRAME HEAT EXCHANGER (EVAPORATOR) HEATER	215
OVERALL UNIT INSPECTION.....	216
BACNET, MODBUS AND YORKTALK 2 COMMUNICATIONS.....	217
BACnet and Modbus Communications	220
Analog Write Points	220
Binary Write Points	220
Analog Read Only Points.....	220
Binary Monitor Only Points	220
Communications Data Map Notes:	220
Yorktalk 2 Communications.....	224
Received Data (Control Data).....	224
Transmitted Data.....	224
TEMPERATURE CONVERSION CHART	228
R410-A PRESSURE TEMPERATURE CHART.....	229
Adding Refrigerant Charge After Commissioning.....	229

LIST OF FIGURES

FIGURE 1 - YCAL AIR-COOLED SCROLL CHILLERS	19
FIGURE 2 - UNIT COMPONENTS SINGLE SYSTEM UNITS.....	25
FIGURE 3 - CONTROL/POWER PANEL COMPONENTS SINGLE SYSTEM UNITS.....	26
FIGURE 4 - UNIT COMPONENTS DUAL SYSTEM UNITS.....	27
FIGURE 5 - CONTROL/POWER PANEL COMPONENTS DUAL SYSTEM UNITS	28
FIGURE 6 - REFRIGERANT FLOW DIAGRAM.....	34
FIGURE 7 - UNIT RIGGING/LIFTING (YCAL0019 – 0033 SINGLE CIRCUIT MODELS ONLY).....	36
FIGURE 8 - UNIT RIGGING/LIFTING (YCAL0043- 0066 DUAL CIRCUIT MODELS).....	37
FIGURE 9 - CHILLED LIQUID SYSTEM.....	41
FIGURE 10 - SINGLE-POINT SUPPLY CONNECTION – TERMINAL BLOCK, NON-FUSED DISCONNECT SWITCH OR CIRCUIT BREAKER (0043 – 0066)	44
FIGURE 11 - CONTROL WIRING	45
FIGURE 12 - CONTROL WIRING DIAGRAM, SINGLE CIRCUIT, IPU II.....	60
FIGURE 13 - CONTROL WIRING DIAGRAM, SINGLE CIRCUIT, IPU II.....	63
FIGURE 14 - CONTROL WIRING DIAGRAM, DUAL CIRCUIT, IPU II	64
FIGURE 15 - CONTROL WIRING DIAGRAM, DUAL CIRCUIT, IPU II	66
FIGURE 16 - CONTROL WIRING DIAGRAM, DETAILS, SINGLE CIRCUIT.....	69
FIGURE 17 - CONTROL WIRING DIAGRAM, DETAILS, DUAL CIRCUIT	70
FIGURE 18 - POWER WIRING, SINGLE CIRCUIT	72
FIGURE 19 - POWER WIRING, SINGLE CIRCUIT	74
FIGURE 20 - POWER WIRING, SINGLE CIRCUIT	76
FIGURE 21 - POWER WIRING, SINGLE CIRCUIT	78
FIGURE 22 - POWER WIRING, DUAL CIRCUIT.....	81
FIGURE 23 - POWER WIRING, DUAL CIRCUIT.....	82
FIGURE 24 - CONNECTION WIRING, SINGLE CIRCUIT	84
FIGURE 25 - CONNECTION WIRING, SINGLE CIRCUIT	86
FIGURE 26 - CONNECTION WIRING, SINGLE CIRCUIT	88
FIGURE 27 - CONNECTION WIRING, SINGLE CIRCUIT	90
FIGURE 28 - CONNECTION WIRING, DUAL CIRCUIT	93
FIGURE 29 - CONNECTION WIRING, DUAL CIRCUIT	94
FIGURE 30 - UNIT CLEARANCES – ALL MODELS.....	132
FIGURE 31 - ONE INCH DEFLECTION SPRING ISOLATOR CROSS-REFERENCE	136
FIGURE 32 - ONE INCH DEFLECTION SPRING ISOLATORS INSTALLATION INSTRUCTIONS	137
FIGURE 33 - DURULENE ISOLATOR CROSS-REFERENCE.....	138
FIGURE 34 - INSTALLATION OF DURULENE VIBRATION ISOLATORS	139
FIGURE 35 - TWO INCH DEFLECTION SEISMIC ISOLATOR CROSS-REFERENCE	140
FIGURE 36 - SEISMIC ISOLATOR INSTALLATION AND ADJUSTMENT.....	141
FIGURE 37 - ONE INCH DEFLECTION SPRING ISOLATOR CROSS-REFERENCE (CIP-X)	142
FIGURE 38 - NEOPRENE ISOLATOR CROSS-REFERENCE	144
FIGURE 39 - TWO INCH DEFLECTION, SEISMIC SPRING ISOLATOR CROSS-REFERENCE	145
FIGURE 40 - SLRS SEISMIC ISOLATOR INSTALLATION AND ADJUSTMENT	146
FIGURE 41 - LEAVING WATER TEMPERATURE CONTROL EXAMPLE	184
FIGURE 42 - SETPOINT ADJUST	184
FIGURE 43 - YCAL0019 – YCAL0033 FAN LOCATION (TYPICAL).....	188
FIGURE 44 - CAL0043 – YCAL0066 FAN LOCATION (TYPICAL).....	189
FIGURE 45 - TYPICAL VFD LOCATION.....	190
FIGURE 46 - LIQUID LINE SENSING BULB LOCATION	190
FIGURE 47 - POTENTIOMETER SETTINGS.....	190
FIGURE 48 - WIRING	191
FIGURE 49 - TYPICAL VFD ENCLOSURE LOCATIONS.....	192
FIGURE 50 - TYPICAL VFD ENCLOSURE CONFIGURATIONS	193
FIGURE 51 - POTENTIOMETER SETTINGS.....	194
FIGURE 52 - INVERTER POWER WIRING SCHEMATIC.....	194
FIGURE 53 - INVERTER WIRING	195
FIGURE 54 - TYPICAL VFD ENCLOSURE LOCATIONS.....	196
FIGURE 55 - TYPICAL VFD ENCLOSURE CONFIGURATIONS	197
FIGURE 56 - INVERTER POWER WIRING SC.....	198

LIST OF FIGURES (CONT'D)

FIGURE 57 - POTENTIOMETER SETTINGS..... 198
FIGURE 58 - INVERTER WIRING 199
FIGURE 59 - MICROBOARD LAYOUT.....206
FIGURE 60 - /O BOARD RELAY CONTACT ARCHITECTURE.....210
FIGURE 61 - PRINTER TO MICROBOARD ELECTRICAL CONNECTIONS..... 211
FIGURE 62 - MICRO PANEL CONNECTIONS.....218

LIST OF TABLES

TABLE 1 - TEMPERATURES AND FLOWS	47
TABLE 2 - VOLTAGE LIMITATIONS.....	47
TABLE 3 - TEMPERATURES AND FLOWS (SI).....	50
TABLE 4 - VOLTAGE LIMITATIONS.....	50
TABLE 5 - ETHYLENE AND PROPOLYNE GLYCOL CORRECTION FACTORS	50
TABLE 6 - PHYSICAL DATA (ENGLISH)	53
TABLE 7 - ELECTRICAL DATA (ENGLISH).....	54
TABLE 8 - MICRO PANEL POWER SUPPLY	58
TABLE 9 - VOLTAGE RANGE	58
TABLE 10 - SETPOINTS ENTRY LIST	150
TABLE 11 - STATUS KEY MESSAGES QUICK REFERENCE LIST	160
TABLE 12 - OPERATION DATA	164
TABLE 13 - COOLING SETPOINTS, PROGRAMMABLE LIMITS AND DEFAULTS	171
TABLE 14 - PROGRAM KEY LIMITS AND DEFAULT.....	173
TABLE 15 - SETPOINTS QUICK REFERENCE LIST.....	176
TABLE 16 - UNIT KEYS OPTIONS PROGRAMMING QUICK REFERENCE LIST	182
TABLE 17 - SAMPLE COMPRESSOR STAGING FOR RETURN WATER CONTROL.....	185
TABLE 18 - RETURN CHILLED LIQUID CONTROL FOR 4 COMPRESSORS (6 STEPS)	186
TABLE 19 - RETURN CHILLED LIQUID CONTROL FOR 4 COMPRESSORS (6 STEPS)	186
TABLE 20 - YCAL0019 – YCAL0033 CONDENSER FAN CONTROL USING DISCHARGE PRESSURE	188
TABLE 21 - YCAL0019 – YCAL0033 CONDENSER FAN CONTROL USING DISCHARGE PRESSURE ONLY	188
TABLE 22 - YCAL0043 – YCAL0066 CONDENSER FAN CONTROL USING DISCHARGE PRESSURE.	189
TABLE 23 - YCAL0043 – YCAL0066 CONDENSER FAN CONTROL USING DISCHARGE PRESSURE ONLY	189
TABLE 24 - YCAL0019 – 0028 VFD LOW AMBIENT OPTION – CONDENSER FAN CONTROL OPERATION.....	192
TABLE 25 - VFD JUMPERS.....	193
TABLE 26 - YCAL033 VFD LOW AMBIENT OPTION – CONDENSER FAN CONTROL OPERATION.....	195
TABLE 27 - VFD JUMPERS.....	197
TABLE 28 - YCAL0043-0066 VFD LOW AMBIENT OPTION – CONDENSER FAN CONTROL OPERATION	199
TABLE 29 - COMPRESSOR OPERATION –LOAD LIMITING.....	200
TABLE 30 - I/O DIGITAL INPUTS.....	205
TABLE 31 - I/O DIGITAL OUTPUTS.....	205
TABLE 32 - I/O ANALOG INPUTS	205
TABLE 33 - I/O ANALOG OUTPUTS	205
TABLE 34 - OUTDOOR AIR SENSOR TEMPERATURE/VOLTAGE / CORRELATION.....	207
TABLE 35 - ENTERING/LEAVING CHILLED LIQUID TEMPERATURE SENSOR.....	208
TABLE 36 - PRESSURE TRANSDUCERS	209
TABLE 37 - TROUBLESHOOTING	212
TABLE 38 - MINIMUM, MAXIMUM AND DEFAULT VALUES	218
TABLE 39 - VALUES REQUIRED FOR BAS COMMUNICATION.....	219
TABLE 40 - REAL TIME ERROR NUMBERS	219
TABLE 41 - BACNET AND MODBUS COMMUNICATIONS DATA MAP.....	221
TABLE 42 - YORKTALK 2 COMMUNICATIONS DATA MAP	225

THIS PAGE INTENTIONALLY LEFT BLANK

SECTION 1 – GENERAL CHILLER INFORMATION AND SAFETY

INTRODUCTION

YORK YCAL0019-0066 (15-65 ton, 53-218Kw) chillers are manufactured to the highest design and construction standards to ensure high performance, reliability and adaptability to all types of air conditioning installations.

The unit is intended for cooling water or glycol solutions and is not suitable for purposes other than those specified in this manual.

This manual contains all the information required for correct installation and commissioning of the unit, together with operating and maintenance instructions. The manuals should be read thoroughly before attempting to operate or service the unit.

All procedures detailed in the manuals, including installation, commissioning and maintenance tasks must only be performed by suitably trained and qualified personnel.

The manufacturer will not be liable for any injury or damage caused by incorrect installation, commissioning, operation or maintenance resulting from a failure to follow the procedures and instructions detailed in the manuals.

WARRANTY

Johnson Controls warrants all equipment and materials against defects in workmanship and materials for a period of eighteen months from date of shipment, unless labor or extended warranty has been purchased as part of the contract.

The warranty is limited to parts only replacement and shipping of any faulty part, or sub-assembly, which has failed due to poor quality or manufacturing errors. All claims must be supported by evidence that the failure has occurred within the warranty period, and that the unit has been operated within the designed parameters specified.

All warranty claims must specify the unit model, serial number, order number and run hours/starts. Model and serial number information is printed on the unit identification plate.

The unit warranty will be void if any modification to the unit is carried out without prior written approval from Johnson Controls.

For warranty purposes, the following conditions must be satisfied:

- The initial start of the unit must be carried out by trained personnel from an Authorized Johnson Controls Service Center (see Commissioning Page 147).
- Only genuine YORK approved spare parts, oils, coolants, and refrigerants must be used.
- All the scheduled maintenance operations detailed in this manual must be performed at the specified times by suitably trained and qualified personnel (see Maintenance Section, Page 215).
- Failure to satisfy any of these conditions will automatically void the warranty (see Warranty Policy).

SAFETY

Standards for Safety

YCAL chillers are designed and built within an ISO 9002 accredited design and manufacturing organization. The chillers comply with the applicable sections of the following Standards and Codes:

- ANSI/ASHRAE Standard 15 - Safety Code for Mechanical Refrigeration.
- ANSI/NFPA Standard 70 - National Electrical Code (N.E.C.).
- ASME Boiler and Pressure Vessel Code- Section VIII Division 1.
- ARI Standard 550/590-98- Water Chilling Packages Using the Vapor Compression Cycle.
- ASHRAE 90.1- Energy Efficiency Compliance.
- ARI 370- Sound Rating of Large Outdoor Refrigeration and Air Conditioning Equipment.
- Conform to Intertek Testing Services, formerly ETL, for construction of chillers and provide ETL/cETL listing label.
- Manufactured in facility registered to ISO 9002.
- OSHA – Occupational Safety and Health Act.

In addition, the chillers conform to Underwriters Laboratories (U.L.) for construction of chillers and provide U.L./cU.L. Listing Label.

Responsibility for Safety

Every care has been taken in the design and manufacture of the unit to ensure compliance with the safety requirements listed above. However, the individual operating or working on any machinery is primarily responsible for:

- Personal safety, safety of other personnel, and the machinery.
- Correct utilization of the machinery in accordance with the procedures detailed in the manuals.

ABOUT THIS MANUAL

The following terms are used in this document to alert the reader to areas of potential hazard.



A **WARNING** is given in this document to identify a hazard, which could lead to personal injury. Usually an instruction will be given, together with a brief explanation and the possible result of ignoring the instruction.



A **CAUTION** identifies a hazard which could lead to damage to the machine, damage to other equipment and/or environmental pollution. Usually an instruction will be given, together with a brief explanation and the possible result of ignoring the instruction.

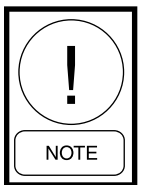

A **NOTE** is used to highlight additional information, which may be helpful to you but where there are no special safety implications.

The contents of this manual include suggested best working practices and procedures. These are issued for

guidance only, and they do not take precedence over the above stated individual responsibility and/or local safety regulations.

This manual and any other document supplied with the unit are the property of Johnson Controls which reserves all rights. They may not be reproduced, in whole or in part, without prior written authorization from an authorized Johnson Controls representative.

MISUSE OF EQUIPMENT

Suitability for Application

The unit is intended for cooling water or glycol solutions and is not suitable for purposes other than those specified in these instructions. Any use of the equipment other than its intended use, or operation of the equipment contrary to the relevant procedures may result in injury to the operator, or damage to the equipment.

The unit must not be operated outside the design parameters specified in this manual.

Structural Support

Structural support of the unit must be provided as indicated in these instructions. Failure to provide proper support may result in injury to the operator, or damage to the equipment and/or building.

Mechanical Strength

The unit is not designed to withstand loads or stresses from adjacent equipment, pipework or structures. Additional components must not be mounted on the unit. Any such extraneous loads may cause structural failure and may result in injury to the operator, or damage to the equipment.

General Access

There are a number of areas and features, which may be a hazard and potentially cause injury when working on the unit unless suitable safety precautions are taken. It is important to ensure access to the unit is restricted to suitably qualified persons who are familiar with the potential hazards and precautions necessary for safe operation and maintenance of equipment containing high temperatures, pressures and voltages.

Pressure Systems

The unit contains refrigerant vapor and liquid under pressure, release of which can be a danger and cause injury. The user should ensure that care is taken during installation, operation and maintenance to avoid damage to the

pressure system. No attempt should be made to gain access to the component parts of the pressure system other than by suitably trained and qualified personnel.

Electrical

The unit must be grounded. No installation or maintenance work should be attempted on the electrical equipment without first switching power OFF, isolating and locking-off the power supply. Servicing and maintenance on live equipment must only be performed by suitably trained and qualified personnel. No attempt should be made to gain access to the control panel or electrical enclosures during normal operation of the unit.

Rotating Parts

Fan guards must be fitted at all times and not removed unless the power supply has been isolated. If ductwork is to be fitted, requiring the wire fan guards to be removed, alternative safety measures must be taken to protect against the risk of injury from rotating fans.

Sharp Edges

The fins on the air-cooled condenser coils have sharp metal edges. Reasonable care should be taken when working in contact with the coils to avoid the risk of minor abrasions and lacerations. The use of gloves is recommended.

Frame rails, brakes, and other components may also have sharp edges. Reasonable care should be taken when working in contact with any components to avoid risk of minor abrasions and lacerations.

Refrigerants and Oils

Refrigerants and oils used in the unit are generally non-toxic, non-flammable and non-corrosive, and pose no special safety hazards. Use of gloves and safety glasses is, however, recommended when working on the unit. The build up of refrigerant vapor, from a leak for example, does pose a risk of asphyxiation in confined or enclosed spaces and attention should be given to good ventilation.

High Temperature and Pressure Cleaning

High temperature and pressure cleaning methods (e.g. steam cleaning) should not be used on any part of the pressure system as this may cause operation of the pressure relief device(s). Detergents and solvents, which may cause corrosion, should also be avoided.

Emergency Shutdown

In case of emergency, the control panel is fitted with a Unit Switch to stop the unit in an emergency. When operated, it removes the low voltage 120VAC electrical supply from the inverter system, thus shutting down the unit.

THIS PAGE INTENTIONALLY LEFT BLANK

SECTION 2 – PRODUCT DESCRIPTION

INTRODUCTION

YORK Millennium® Air-Cooled Scroll Chillers provide chilled water for all air conditioning applications using central station air handling or terminal units. They are completely self-contained and are designed for outdoor (roof or ground level) installation. Each complete packaged unit includes hermetic scroll compressors, a liquid cooler, air cooled condenser, a charge of refrigerant R-410A and a weather resistant microprocessor control center, all mounted on a pressed steel base.

The units are completely assembled with all interconnecting refrigerant piping and internal wiring, ready for field installation.

Prior to delivery, the packaged unit is pressure-tested, evacuated, and fully charged with Refrigerant-R410A and oil. After assembly, a complete operational test is performed with water flowing through the cooler to assure that the refrigeration circuit operates correctly.

The unit structure is heavy-gauge, galvanized steel. This galvanized steel is coated with baked-on powder paint, which, when subjected to ASTM B117 1000 hour, salt spray testing, yields a minimum ASTM 1654 rating of “6”. Corrosion resistant wire mesh panels are added to protect the condenser coil from incidental damage and restrict unauthorized access to internal components. Units are designed in accordance with NFPA 70 (National Electric Code), ASHRAE/ANSI 15 Safety code for mechanical refrigeration, ASME, Listed and labeled with Intertek Testing Services (ETL) and rated in accordance with ARI Standard 550/590-2003.

All exposed power wiring is routed through liquid-tight, non-metallic conduit.

GENERAL SYSTEM DESCRIPTION

Compressors

The chiller has suction-gas cooled, hermetic, scroll compressors. The YCAL compressors incorporate a compliant scroll design in both the axial and radial direction. All rotating parts are statically and dynamically balanced. A large internal volume and oil reservoir provides greater liquid tolerance. Compressor crankcase heaters are also included for extra protection against liquid migration.

Evaporator (Heat Exchanger)

The Brazed Plate Heat Exchanger is equipped with a heater controlled by the microprocessor. The heater provides freeze protection for the cooler down to -20 °F (-29 °C) ambient. The cooler is covered with 3/4" (19mm) flexible, closed-cell, foam insulation (K~0.25).

Braze plate heat exchangers shall be UL (Underwriters Laboratories) listed. Installing contractor must include accommodations in the chilled water piping to allow proper drainage and venting of the heat exchanger. Water inlet and outlet connections are grooved for compatibility with factory supplied victaulic connections.



LD10950

FIGURE 1 - YCAL AIR-COOLED SCROLL CHILLERS

The heat exchanger is a brazed plate stainless steel construction, single or dual circuit heat exchanger capable of refrigerant working pressure of 650 PSIG (3103 kPa) and liquid side pressure of 150 PSIG (1034 kPa) (Option for 300 PSIG [2068 kPa] available). Each heat exchanger is covered in 3/4" (19mm) flexible, closed cell insulation, thermal conductivity of 0.26k ([BTU/HR-FT² - °F] /in) maximum.

A strainer with a mesh size between .5 and 1.5 mm (40 mesh) is recommended upstream of the heat exchanger to prevent clogging.

Condenser

Coils

Fin and tube condenser coils of seamless, internally-enhanced, high-condensing-coefficient, corrosion resistant copper tubes are arranged in staggered rows, mechanically expanded into aluminum fins. Integral subcooling is included. The design working pressure of the coil is 650 PSIG (45 bar).

Low Sound Fans

The condenser fans are composed of corrosion resistant aluminum hub and glass-fiber reinforced composite blades molded into a low noise airfoil section. They are designed for maximum efficiency and are statically and dynamically balanced for vibration free operation. They are directly driven by independent motors, and positioned for vertical air discharge. All blades are statically and dynamically balanced for vibration-free operation. The fan guards are constructed of heavy-gauge, rust-resistant, PVC coated steel wire.

Motors

The fan motors are Totally Enclosed Air-Over (TEAO), direct drive, 6 pole, current protected. They feature ball bearings that are double-sealed and permanently lubricated.

MILLENIUM CONTROL CENTER

All controls are contained in a NEMA 3R/12 (and equivalent to IP55*) cabinet with hinged outer door and include Liquid Crystal Display (LCD) with Light Emitting Diode (LED) backlighting for outdoor viewing and includes:

- Two display lines
- Twenty characters per line

Display/Print

Color coded 12-button non-tactile keypad with sections for display and print of typical information:

- Chilled liquid temperatures.
- Ambient temperature.
- System pressures (each circuit).
- Operating hours and starts (each compressor).
- Print calls up to the liquid crystal display.
- Operating data for the systems.
- History of fault shutdown data for up to the last six fault shutdown conditions.
- An RS-232 port, in conjunction with this press-to-print button, is provided to permit the capability of hard copy print-outs via a separate printer (by others).

Entry

This section is used to enter setpoints or modify system values.

Setpoints

Updating can be performed to:

- Chilled liquid temperature setpoint and range
- Remote reset temperature range
- Set daily schedule/holiday for start/stop
- Manual override for servicing
- Low and high ambient cutouts
- Number of compressors
- Low liquid temperature cutout
- Low suction pressure cutout
- High discharge pressure cutout
- Anti-recycle timer (compressor start cycle time)
- Anti-coincident timer (delay compressor starts)

Unit

This section is used to:

- Set time
- Set unit options

* Intensity of Protection European Standard

** International Electrotechnical Commission

Unit On/Off Switch

The microprocessor control center is capable of displaying the following:

- Return and leaving liquid temperature
- Low leaving liquid temperature cutout setting
- Low ambient temperature cutout setting
- Outdoor air temperature
- English or Metric data
- Suction pressure cutout setting
- Each system suction pressure
- Discharge pressure (optional)
- Liquid Temperature Reset via a YORK ISN DDC or Building Automation System (by others) via:
 - a pulse width modulated (PWM) input as standard.
 - a 4 to 20 milliamp or 0 to 10 VDC input with the optional B.A.S. interface option.
- Anti-recycle timer status for each system
- Anti-coincident system start timer condition
- Compressor run status
- No cooling load condition
- Day, date and time
- Daily start/stop times
- Holiday status
- Automatic or manual system lead/lag control
- Lead system definition
- Compressor starts and operating hours (each compressor)
- Status of hot gas valves, evaporator heater and fan operation

- Run permissive status
- Number of compressors running
- Liquid solenoid valve status
- Load and unload timer status
- Water pump status

Provisions are included for:

- Pumpdown at shutdown.
- Optional remote chilled water temperature reset.
- Two steps of demand load limiting from an external building automation system.

Unit alarm contacts are standard.

The operating program is stored in non-volatile memory (EPROM) to eliminate chiller failure due to AC powered failure/battery discharge. Programmed set-points are retained in lithium battery-backed RTC memory for 5 years minimum.

COMMUNICATIONS

- Native communication capability for BACnet (MS/TP) and Modbus
- Optional communication available for N2 and LON via eLink option

POWER PANEL

Each panel contains:

- Compressor power terminals
- Compressor motor starting contactors per I.E.C.**
- Control power terminals to accept incoming for 115-1-60 control power
- Fan contactors and overload current protection

The power wiring is routed through liquid-tight conduit to the compressors and fans.

* Intensity of Protection European Standard

** International Electrotechnical Commission

ACCESSORIES AND OPTIONS

Power Options

Compressor Power Connection

Single-point (YCAL0019-0066) terminal block connection is provided as standard. The following power connections are available as options. (See electrical data for specific voltage and options availability) (**Factory-Mounted**).

Single-Point Supply Terminal Block (Standard on YCAL0019 – 0066 models)

Includes enclosure, terminal-block and interconnecting wiring to the compressors. Separate external protection must be supplied, by others, in the incoming compressor-power wiring. (Do not include this option if either the Single-Point Non-fused Disconnect Switch or Single-Point Circuit Breaker options have been included).

Single-Point Non-Fused Disconnect Switch

Unit-mounted disconnect switch with external, lockable handle (in compliance with Article 440-14 of N.E.C.), can be supplied to isolate the unit power voltage for servicing. Separate external fusing must be supplied, by others in the power wiring, which must comply with the National Electrical Code and/or local codes.

Single-Point Circuit Breaker

A unit mounted circuit breaker with external, lockable handle (in compliance with N.E.C. Article 440-14), can be supplied to isolate the power voltage for servicing (this option includes the Single-Point Power connection).

Control Transformer

Converts unit power voltage to 115-1-60 (0.5 or 1.0 KVA capacity). Factory mounting includes primary and secondary wiring between the transformer and the control panel (**Factory-Mounted**).

Power Factor Correction Capacitors

Will correct unit compressor power factors to a 0.90-0.95 (**Factory-Mounted**).

Control Options

Ambient Kit (Low)

Units will operate to 25 °F (-4 °C). This accessory includes all necessary components to permit chiller operation to 0 °F (-18 °C). This option includes the

Discharge Pressure Transducer / Readout Capability option. For proper head pressure control in applications below 25 °F (-4 °C), where wind gusts may exceed five mph, it is recommended that Optional Condenser Louvered Enclosure Panels also be included (**Factory-Mounted**).

Ambient Kit (High)

Required if units are to operate when the ambient temperature is above 110 °F (43 °C). Includes discharge pressure transducers. This option includes the Discharge Pressure Transducer / Readout Capability option (**Field-Mounted**).

Building Automation System Interface

The factory addition of a Printed Circuit Board to accept a 4 to 20 milliamp, 0 to 10VDC or contact closure input to reset the leaving chiller liquid temperature from a Building Automation System. Only one of following options can be offered on a unit at a time:

- BAS
 - Remote Control Panel
- or
- Multi-unit Sequence Control (**Factory-Mounted**)

The standard unit capabilities include remote start/stop, remote water temperature reset via a PWM input signal or up to two steps of demand (load) limiting depending on model. The standard control panel can be directly connected to a YORK Building Automated System via the standard onboard RS485 communication port.

Language LCD And Keypad Display

Spanish, French, and German unit LCD controls and keypad displays are available. Standard language is English.

Discharge Pressure Transducers And Readout Capability

The addition of pressure transducers allows models to sense and display discharge pressure. This is recommended for brine chilling applications. This option is included with either the low or high ambient kits (**Factory-Mounted**).

Suction Pressure Transducers

Permits unit to sense and display suction pressure. This capability is standard on YCAL0019 through YCAL0066 models.

Motor Current Module

Capable of monitoring compressor motor current. Provides extra protection against compressor reverse rotation, phase-loss and phase imbalance. Option consists of one module per electrical system (**Factory-Mounted**).

Multi-Unit Sequencing

A separate Sequencing Control Center can be provided to handle sequencing control of up to eight chillers in parallel based on mixed liquid temperature (interconnecting wiring by others). Only one of following options can be offered on a unit at a time:

- BAS
- Remote Control Panel
- or
- Multi-unit Sequence Control) (**Factory-Mounted**)

Compressor, Piping, Evaporator Options

Low Temperature Brine

Required for brine chilling below 30 °F (-1 °C) leaving brine temperature for YCAL0019 through YCAL0066 models. Option includes resized thermal expansion valve (**Factory-Mounted**).

Chicago Code Relief Valves

Unit will be provided with relief valves to meet Chicago code requirements (**Factory-Mounted**).

Service Isolation Valve

Service suction and discharge (ball type) isolation valves are added to unit per system. This option also includes a system high pressure relief valve in compliance with ASHRAE 15 (**Factory-Mounted**).

Hot Gas By-Pass

Permits continuous, stable operation at capacities below the minimum step of compressor unloading to as low as 5% capacity (depending on both the unit and operating conditions) by introducing an artificial load on the cooler. Hot gas by-pass is installed on only refrigerant system #1 on two-circuited units (**Factory-Mounted**).

Heat Exchanger 300 PSIG (21 BARG) DWP Waterside

The waterside will be of 300 PSIG (21 barg) instead of the standard 150 PSIG DWP. Included on the Heat Exchanger nozzles are 300 PSIG R.F. flanges. (**Factory-Mounted**). The companion flanges will be field-supplied by others.

Flanges (ANSI/AWWA C-606 Couplings Type)

Consists of two (2) Flange adapters for grooved end pipe (standard 150 psi [10.5 barg] cooler).

Flow Switch

The flow switch or its equivalent must be furnished with each unit. A description of the standard and optional flow switch is as follows:

150 PSIG (10.5 BARG) DWP

For standard units. Johnson Controls model F61MG-1C Vapor-proof SPDT, NEMA 4X switch (150 PSIG [10.5 barg] DWP), -20 °F to 250 °F (-29 °C to 121 °C), with 1" NPT connection for upright mounting in horizontal pipe (**Field-Mounted**).

300 PSIG (21 BARG) DWP

For units with optional 300 PSIG (21 barg) DX cooler. McDonnell and Miller model FS74W Vapor-proof SPDT, NEMA 4X switch (300 PSIG (21 barg) DWP), -20 °F to 300 °F (-29 °C to 149 °C), with 1¼ inch MPT connection for upright mounting in horizontal pipe (**Field-Mounted**).

Differential Pressure Switch

Alternatives to an above mentioned flow switch are: Pretempco model DPS300AP40PF-82582-5 (300 psi max. (21 barg) working pressure), SPDT 5 amp 125/250VAC switch, Range 3 to 45 PSIG (0.2 to 3 barg), deadband 0.5 to 0.8 psi (0.003 to 0.005 barg) , with 1/4" NPTE Pressure Connections.

Condenser And Cabinet Options

Condenser coil protection against corrosive environments is available by choosing any of the following options. For additional application recommendations, refer to FORM 150.12-ES1 (**Factory-Mounted**).

Pre-Coated Fin Condenser Coils

The unit's coils are constructed with black epoxy coated aluminum fins. This can provide corrosion resistance comparable to copper-fin coils in typical sea-shore locations. Either these or the post-coated coils

(below), are recommended for units being installed at the seashore or where salt spray may hit the unit.

Post-Coated Dipped Condenser Coils

The unit's coils are constructed with dipped-cured condenser coils. This is another choice for seashore and other corrosive applications (with the exception of strong alkalies, oxidizers and wet bromine, chlorine and fluorine in concentrations greater than 100 ppm).

Copper Fin Condenser Coils

The unit's coils are constructed with copper fins. (This is not recommended for units in areas where they may be exposed to acid rain).

Enclosure Panels (Unit)

Tamperproof Enclosure Panels prevent unauthorized access to units. Enclosure Panels can provide an aesthetically pleasing alternative to expensive fencing. Additionally, for proper head pressure control, YORK recommends the use of Louvered Panels (described below).

Louvered Panels (Full Unit)

Louvered panels surround the front, back, and sides of the unit. They prevent unauthorized access and visually screen unit components. Unrestricted air flow is permitted through generously sized louvered openings. This option is applicable for any outdoor design ambient temperature up to 115 °F (46 °C) (**Factory-Mounted**).

Sound Reduction / Attenuation Options

One or both of the following sound attenuation options are recommended for residential or other similar sound-sensitive locations. Louvered Panels can be ordered for winter applications where wind gusts may exceed five miles per hour. The following types of enclosure options are available:

Compressor Acoustic Sound Blanket

Each compressor is individually enclosed by an acoustic sound blanket. The sound blankets are made with one layer of acoustical absorbent textile fiber of 5/8" (15mm) thickness; one layer of anti-vibrating heavy material thickness of 1/8" (3mm). Both are closed by two sheets of welded PVC, reinforced for temperature and UV resistance (**Factory-Mounted**).

Ultra Quiet Fans

Lower RPM, 8-pole fan motors are used with steeper-pitch fans (**Factory-Mounted**).

Vibration Isolators

Level adjusting, spring type 1" (25.4mm) or seismic deflection or neoprene pad isolators for mounting under unit base rails (**Field-Mounted**).

UNIT COMPONENTS - YCAL0043 - 0066

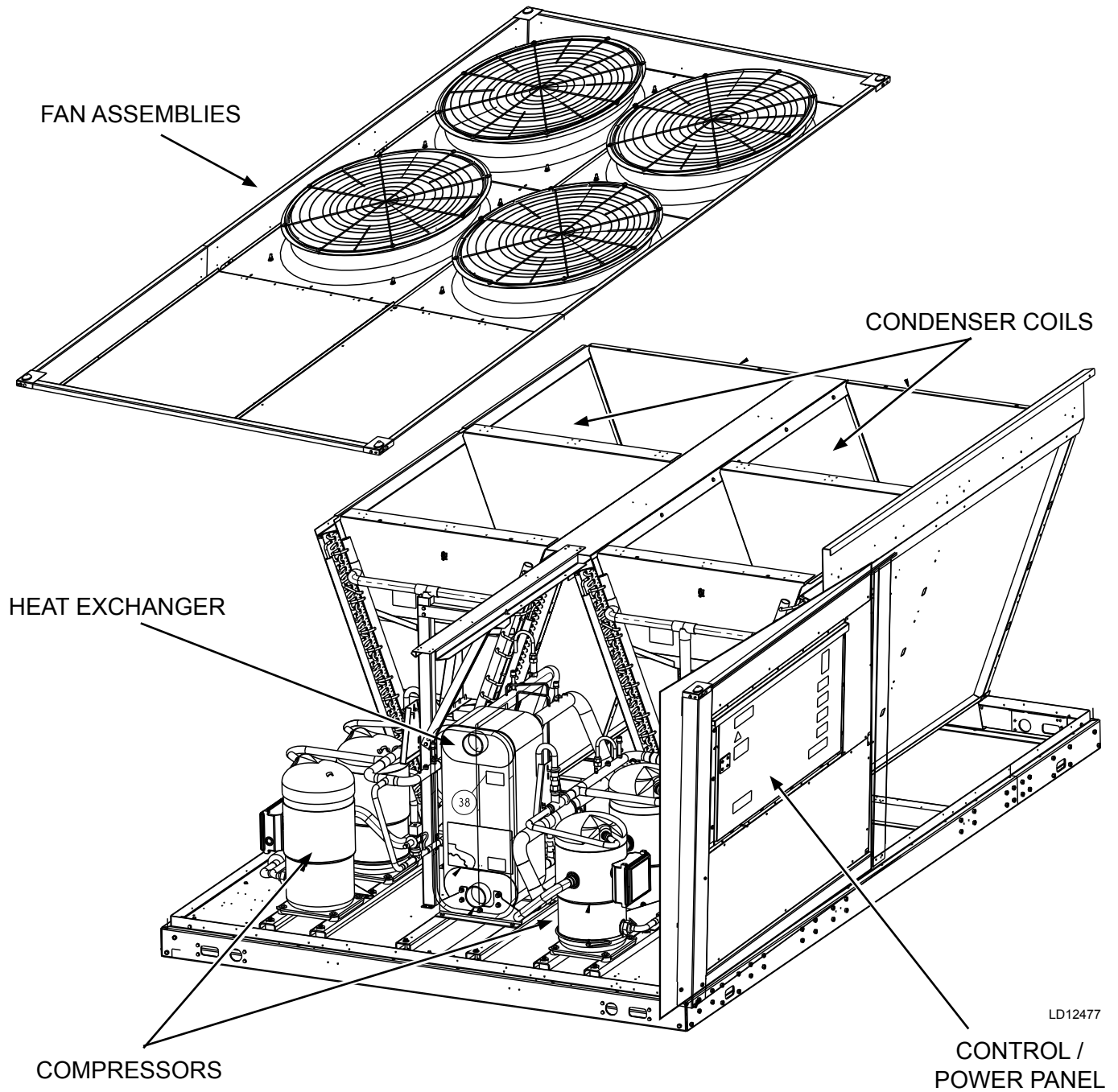

FIGURE 4 - UNIT COMPONENTS DUAL SYSTEM UNITS

CONTROL / POWER PANEL COMPONENTS - YCAL0043 – 0066

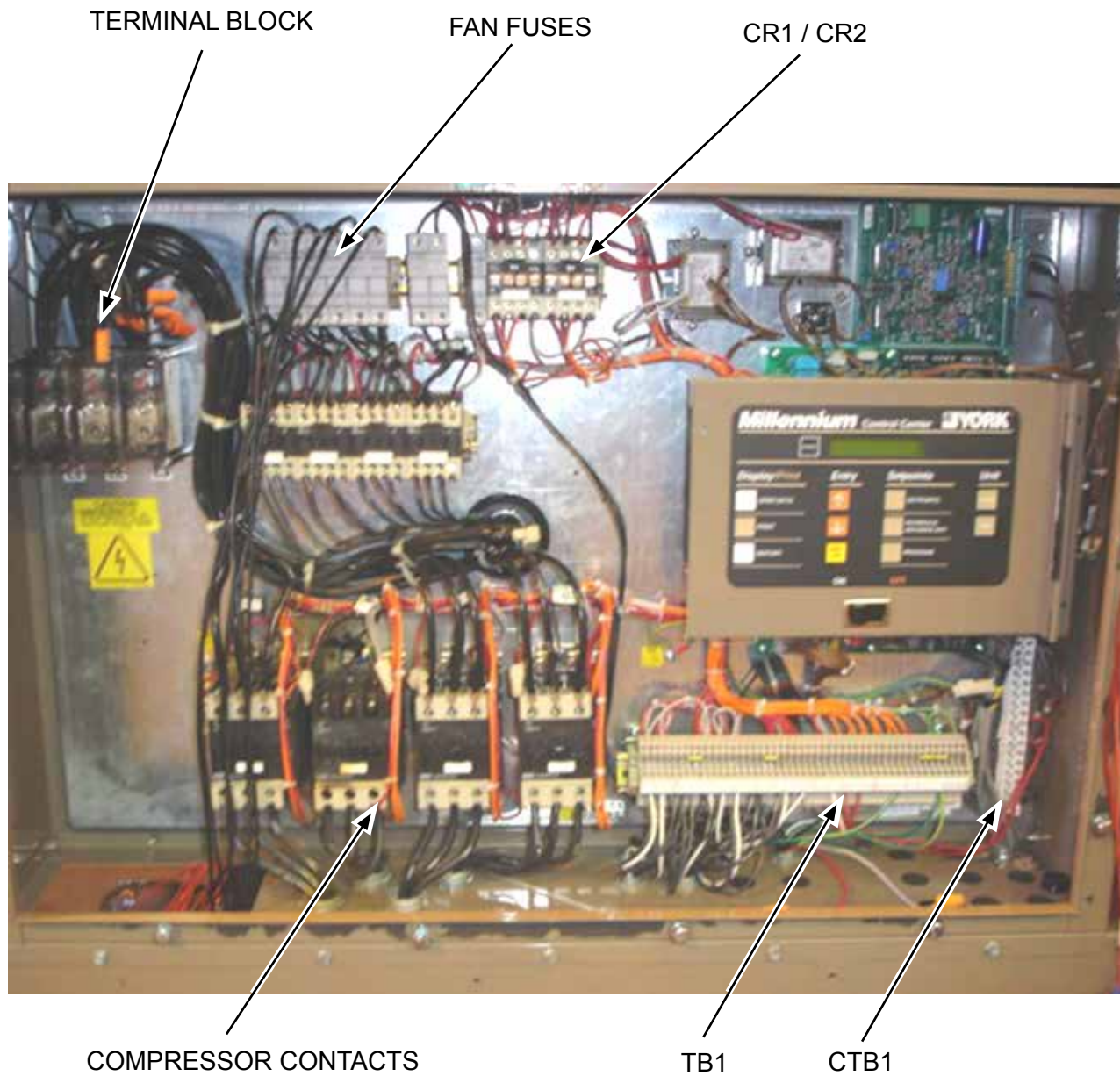

FIGURE 5 - CONTROL/POWER PANEL COMPONENTS DUAL SYSTEM UNITS

LD11458a

PRODUCT IDENTIFICATION NUMBER (PIN)

BASIC UNIT NOMENCLATURE

YCAL0043EE 46XEA

1	2	3	4	5	6	7	8	9	10	11	12	13	14	15
BASE PRODUCT TYPE				NOMINAL CAPACITY				UNIT DESIGNATOR	REFRIGERANT	VOLTAGE/STARTER			DESIGN/DEVELOPMENT LEVEL	
Y	C	A	: YORK : Chiller : Air-Cooled L : Scroll	0	#	#	#	E : High Efficiency	E : R-410A	1	7	: 200 / 3 / 60	E	: Design Series E
				1	#	#	#			2	8	: 230 / 3 / 60	A	: Engineering
										4	0	: 380 / 3 / 60		Change
										4	6	: 460 / 3 / 60		or PIN Level
										5	8	: 575 / 3 / 60		
													X	: Across the Line

FEATURE	DESCRIPTION	OPTION	DESCRIPTION
MODEL	Model (PIN 1-4)	YCAL	YCAL
CAP	Capacity (PIN 5-8)W	0019	0019
		0022	0022
		0028	0028
		0033	0033
		0043	0043
		0046	0046
		0052	0052
		0056	0056
UNIT	Unit Designator (PIN 9)	E	High Efficiency
REF	Refrigerant (PIN 10)	C	R-410a
VOLTS	Voltage (PIN 11 & 12)	17	200/3/60
		28	230/3/60
		40	380/3/60
		46	460/3/60
		58	575/3/60
STARTER	Starter (PIN 13)	X	Across The Line Starter
DESIGN	Design Series (PIN 14)	E	Design Series E
DEV	Development Level (PIN 15)	A	Development Level A
POWER	Power Field (PIN 16 & 17)	SX	Single-Point Terminal Block
		SD	Single-Point Non-Fused Disconnect
		BX	Single-Point Circuit Breaker
		QQ	Special Power Option Required
TRANS	Cntrl Transformer (PIN 18)	X	No Control Transformer Required
		T	Control Transformer Required
		Q	Special Control Transformer Required
PFC	Power Factor Capacitor (PIN 19)	X	No Power Capacitor Required
		C	Power Capacitor Required
		Q	Special Power Capacitor Required

PRODUCT IDENTIFICATION NUMBER (PIN) (CONT'D)

FEATURE	DESCRIPTION	OPTION	DESCRIPTION
AMB	Ambient Kits (PIN 20)	X	No Ambient Kits Required
		L	Low Ambient Kits Required
		H	High Ambient Kits Required
		A	High/Low Ambient Kits Required
		Q	Special Ambient Kits Required
BAS	BAS Reset/Offset (PIN 21)	X	No BAS Reset/Offset Required
		M	ISN Microgateway Required
		T	BAS Reset/Offset Required
		Q	Special BAS Reset/Offset Required
LCD	Language (PIN 22)	X	English
		S	Spanish
		F	French
		G	German
		Q	Special Language Required
RDOUT	Readout Kits (PIN 23)	X	No Readout Kit Required
		R	Discharge Readout Kit Required
		Q	Special Pressure Readout Required
SAFETY	Safety Codes (PIN 24)	L	N American Safety Code (Cul/Cet)
SENSOR	(PIN 25)	X	No Option Required
		Q	Special Quote
PUMP	(PIN 26)	X	No Motor Current
		C	Motor Current Readout
		Q	Special Quote
REMOTE	Remote Panel (PIN 27)	X	No Remote Panel Required
		O	OptiView Remote Panel Required
		Q	Special Remote Panel Required
SEQ	Sequence Kit (PIN 28)	X	No Sequence Kit Required
		S	Sequence Kit Required= {SEQ/S}
		Q	Special Sequence Required
TEMP	Leaving Water Temp (PIN 29, 30)	45	Leaving Water Temp= {TEMP/NUM} Degrees
		QQ	Special LWT Requirements
CHICAGO	Chicago Code Kit (PIN 31)	X	No Chicago Code Kit Required
		C	Chicago Code Kit Required
		S	Service Isolation Valves
		B	Both Chicago Code & Serv Isolation
		Q	Special Chicago Code Kit Required
VALVES	Valves (PIN 32)	X	Standard Valves Required
		Q	Special Optional Valves Required
HGBP	Hot Gas Bypass (PIN 33)	X	No Hot Gas Bypass Required
		1	Hot Gas Bypass Required-1 Circuit
		2	Hot Gas Bypass Required-2 Circuit
		Q	Special Hot Gas Required
GAUGE	(PIN 34)	X	No Option Required
		Q	Special Quote

PRODUCT IDENTIFICATION NUMBER (PIN) (CONT'D)

FEATURE	DESCRIPTION	OPTION	DESCRIPTION
OVERLOAD	(PIN 35)	X	No Option Required
		Q	Special Quote
PIN 36	(PIN 36)	X	No Option Required
		Q	Special Quote
HTR	Crankcase Heater (PIN 37)	X	Crankcase Heater Standard
		Q	Special Crankcase Heater Required
DWP	DWP (PIN 38)	X	150 PSIG DWP Waterside
		3	300 PSIG DWP Waterside
		Q	Special DWP
INS	Insulation (PIN 39)	X	Standard Insulation
		D	Double Thick Insulation
		Q	Special Insulation Required
FLANGES	Flanges (PIN 40)	X	Standard Victaulic
		V	Victaulic to Flange Adapter
		Q	Special Flanges Required
FLOW	Flow Switch (PIN 41)	X	No Flow Switch Required
		S	One Flow Switch Required
		T	Two Flow Switches Required
		U	Three Flow Switches Required
		D	One Differential Pressure Switch Required
		E	Two Differential Pressure Switches Required
		F	Three Differential Pressure Switches Required
		Q	Special Flow Switch Required
VESSEL	Vessel Codes (PIN 42)	X	UL Pressure Code Vessel
		A	ASME Pressure Vessel Code
		Q	Special Pressure Vessel Code
CLR	Cooler (PIN 43)	X	Standard Cooler Required
		R	Remote Cooler Required
		Q	Special Cooler Required
PIN 44	(PIN 44)	X	No Option Required
		Q	Special Quote
COILS	Coils (PIN 45)	X	Aluminum Coil
		B	Pre-Coated Fin Coil
		C	Copper Coil
		P	Post-Coated Dipped Coil
		Q	Special Coil
PIN 46	(PIN 46)	X	No Option Required
		Q	Special Quote
FANMOTORS	Fan Motors (PIN 47)	X	TEAO Fan Motors
		Q	Special Fan Motors Required
ENCL	Enclosure Panel (PIN 48)	1	Wire Enclosures-Factory
		7	Louvered Enclosure-Factory
		Q	Special Enclosures Panels

PRODUCT IDENTIFICATION NUMBER (PIN) (CONT'D)

FEATURE	DESCRIPTION	OPTION	DESCRIPTION
ACOUSTIC	Acoustic Blanket (PIN 49)	X	No Acoustic Blanket Required
		B	Acoustic Blanket Required
		Q	Special Acoustic Blanket Required
PIN 50	(PIN 50)	X	No Option Required
		Q	Special Quote
PIN 51	(PIN 51)	X	No Option Required
		Q	Special Quote
FANS	Sound Fans (PIN 52)	X	Standard Low Sound Fans Required
		L	Ultra Low Sound Fans Required
		Q	Special Sound Fans Required
PAINT	(PIN 53)	X	No Option Required
		Q	Special Quote
ISOL	Vibration Isolators (PIN 54)	X	No Isolators Required
		1	1" Deflection Isolators Required
		N	Neoprene Isolators Required
		S	Seismic Isolators Required
		Q	Special Isolators Required
WARRANTY	Warranty (PIN 55)	X	18 months parts only (year 1)
		B	18 months labor (year 1) (entire unit)
		C	30 months parts (year 1&2) (entire unit)
		D	30 months P&L (year 1&2) (entire unit)
		E	48 months Compressor Parts Only (year 1-5)
		F	18 months (year 1) – (entire unit), 48 months P&L (year 2-5) (compressor only)
		G	48 months parts (year 2-5) (entire unit)
		H	18 months labor (year 1) – (entire unit), 48 months (P&L) (year 2-5) (entire unit)
		I	18 months labor (year 1) – (entire unit), 30 months parts (year 1&2) (entire unit)
		J	18 months labor (year 1) – (entire unit), 48 months parts (year 2-5) (compressor only)
		K	18 months labor (year 1) – (entire unit), 48 months parts (year 2-5) (entire unit)
		L	18 months labor (year 1) – (entire unit), 30 months parts (year 1&2) (entire unit) 48 month parts (year2-5) (compressor only)
		M	18 months labor (year 1) – (entire unit), 48 months parts (year 1&2) (entire unit) 48 month P&L (year2-5) (compressor only)
		N	30 months parts (year 1&2) – (entire unit), 48 months parts (year 2-5) (compressor only)
		O	30 months P&L (year 1&2) – (entire unit), 48 months parts (year 2-5) (compressor only)
		P	30 months P&L (year 1&2) – (entire unit), 48 months P&L (year 2-5) (compressor only)
		R	30 months P&L (year 1&2) – (entire unit), 48 months parts (year 2-5) (entire unit)

PRODUCT IDENTIFICATION NUMBER (PIN) (CONT'D)

FEATURE	DESCRIPTION	OPTION	DESCRIPTION
		Q	Special Warranty
REFWTY	Refrigerant Warranty (PIN 56)	X	No Refrigerant Warranty Required
		1	1 Year Refrigerant
		2	2 Year Refrigerant
		5	5 Year Refrigerant
SHIP	Ship Instructions (PIN 57)	X	No Option Required
		A	Buy American Act Compliance
		B	Both Buy American Act Compliance and Container Shipping Kit
		C	Container Shipping Kit (Factory Load)
		P	Container Shipping Kit (Factory Prep)
		Q	Special Quote
PIN 58	(PIN 58)	J	
		Q	Special Quote
PIN 59	(PIN 59)	B	
		Q	Special Quote
PIN 60	(PIN 60)	X	No Option Required
		Q	Special Quote
MFG	Plant of Mfg. (PIN 61)	R	Plant of Manufacture-Monterrey
LOC	Mfg. Location	MEX	Mexico
		SAT	San Antonio
YW	YorkWorks Version	CV	YorkWorks ConVersion
		UV	YorkWorks Version
SQ	Special Quote	Q	Special Quote

REFRIGERANT FLOW DIAGRAM

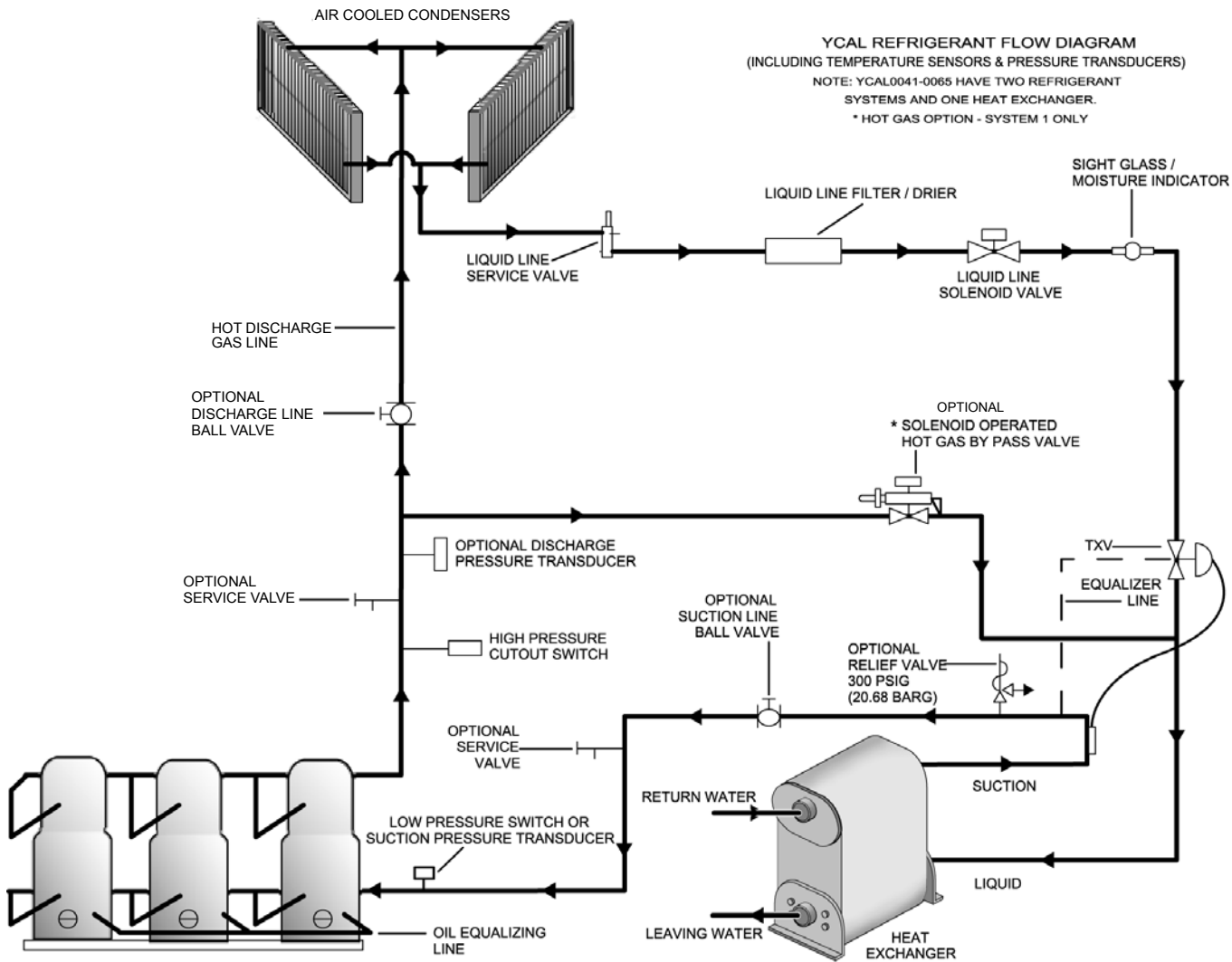

LD11417

FIGURE 6 - REFRIGERANT FLOW DIAGRAM

SECTION 3 – HANDLING AND STORAGE

DELIVERY AND STORAGE

To ensure consistent quality and maximum reliability, all units are tested and inspected before leaving the factory. Units are shipped completely assembled and containing refrigerant under pressure. Units are shipped without export crating unless crating has been specified on the Sales Order.

If the unit is to be put into storage, prior to installation, the following precautions should be observed:

- The chiller must be “blocked” so that the base is not permitted to sag or bow.
- Ensure that all openings, such as water connections, are securely capped.
- Do not store where exposed to ambient air temperatures exceeding 110 °F (43 °C).
- The condensers should be covered to protect the fins from potential damage and corrosion, particularly where building work is in progress.
- The unit should be stored in a location where there is minimal activity in order to limit the risk of accidental physical damage.
- To prevent inadvertent operation of the pressure relief devices the unit must not be steam cleaned.
- It is recommended that the unit is periodically inspected during storage.

INSPECTION

Remove any transit packing and inspect the unit to ensure that all components have been delivered and that no damage has occurred during transit. If any damage is evident, it should be noted on the carrier’s freight bill and a claim entered in accordance with the instructions given on the advice note.

Major damage must be reported immediately to your local Johnson Controls representative.

MOVING THE CHILLER (YCAL0043 – 0066 DUAL SYSTEM ONLY)

Prior to moving the unit, ensure that the installation site is suitable for installing the unit and is easily capable of supporting the weight of the unit and all associated services.

The units are designed to be lifted using cables. A spreader bar or frame should be used in order to prevent damage to the unit from the lifting chains.

Units are provided with lifting eyes in the sides of the base frame, which can be attached to directly using shackles or safety hooks.



The unit must only be lifted by the base frame at the points provided. Never move the unit on rollers, or lift the unit using a forklift truck.

Care should be taken to avoid damaging the condenser cooling fins when moving the unit.

Lifting Weights

For details of weights and weight distribution, refer to the data shipped in the chiller information packet and unit nameplate.



The unit should be lifted by inserting hooks through the holes provided in unit base rails. Spreader bars should be used to avoid crushing the unit frame rails with the lifting chains (see Figure 8).

MOVING THE CHILLER (YCAL0019 – 0033 SINGLE CIRCUIT ONLY)

Prior to moving the unit, ensure that the installation site is suitable for installing the unit and is easily capable of supporting the weight of the unit and all associated services.

The units are designed to be lifted using cables or an appropriate forklift. Refer to the unit data plate for unit weight. When using lifting cables, a spreader bar or frame should be used in order to prevent damage to the unit from the lifting chains.

Units are provided with lifting eyes in the sides of the base frame, which can be attached to directly using shackles or safety hooks.

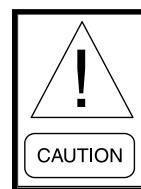

The unit must only be lifted by the base frame at the points provided.

Care should be taken to avoid damaging the condenser cooling fins when moving the unit.

Lifting Weights

For details of weights and weight distribution, refer to the data shipped in the chiller information packet and unit nameplate.

UNIT RIGGING

Lifting Instructions are placed on a label on the chiller and on the shipping bag.

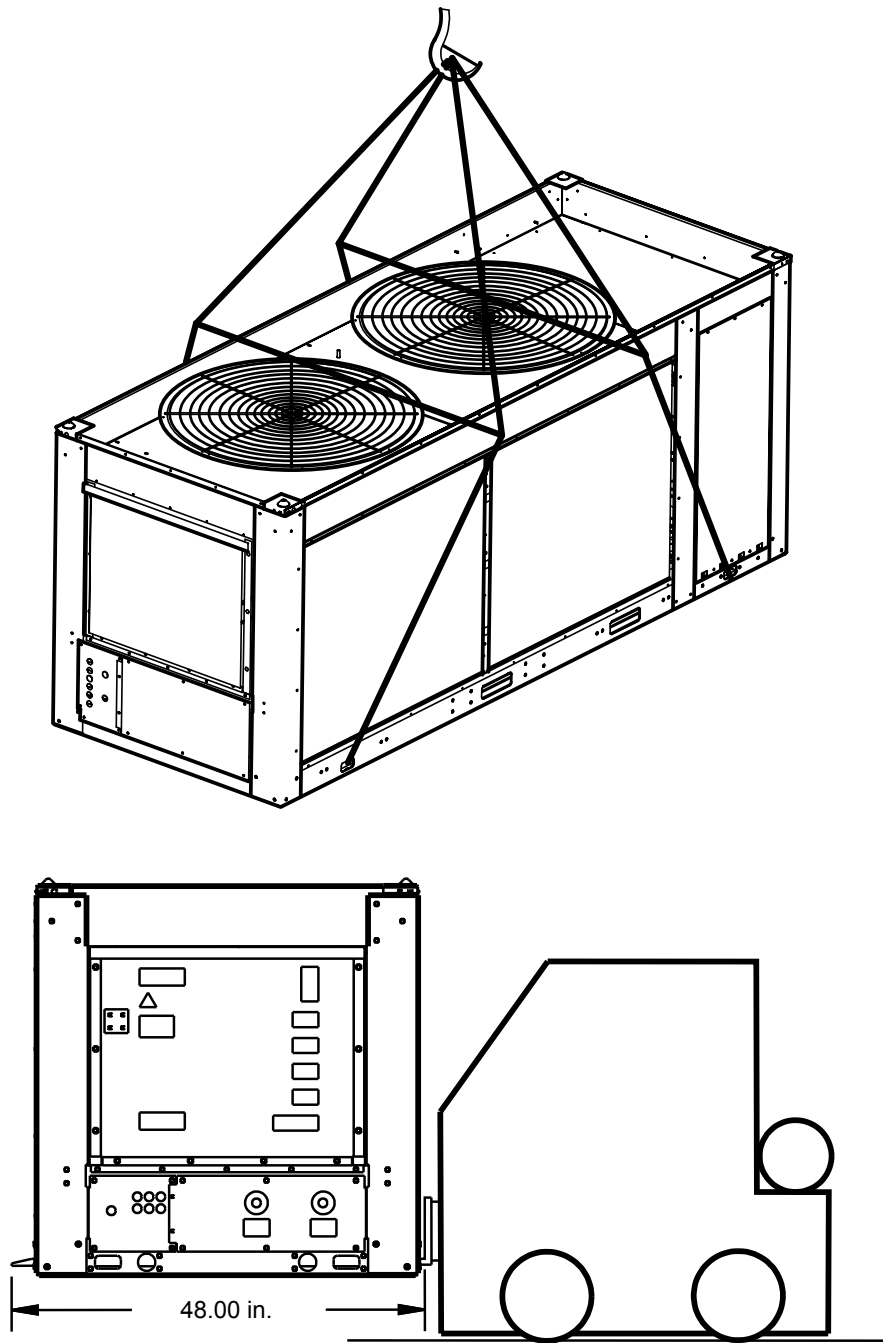

Forks must extend beyond the width of the unit for proper lift. The thickness of the fork blade must be smaller than the opening of the lifting hole. Improper fork positioning could result in damage to the unit.

FIGURE 7 - UNIT RIGGING/LIFTING (YCAL0019 – 0033 SINGLE CIRCUIT MODELS ONLY)

Use spreader bars to avoid lifting chains hitting the chiller.



Never lift the chiller using a forklift or by hooking to the top rails. Use only the lifting holes provided.

Lifting Instructions are placed on a label on the chiller and on the shipping bag.



LD10951

FIGURE 8 - UNIT RIGGING/LIFTING (YCAL0043- 0066 DUAL CIRCUIT MODELS)

THIS PAGE INTENTIONALLY LEFT BLANK

SECTION 4 – INSTALLATION



To ensure warranty coverage, this equipment must be commissioned and serviced by an authorized Johnson Controls service mechanic or a qualified service person experienced in chiller installation. Installation must comply with all applicable codes, particularly in regard to electrical wiring and other safety elements such as relief valves, HP cutout settings, design working pressures, and ventilation requirements consistent with the amount and type of refrigerant charge.



Lethal voltages exist within the control panels. Before servicing, open and tag all disconnect switches.

INSTALLATION CHECKLIST

The following items, 1 through 5, must be checked before placing the units in operation.

1. Inspect the unit for shipping damage.
2. Rig unit using spreader bars.
3. Open the unit only to install water piping system. Do not remove protective covers from water connections until piping is ready for attachment. Check water piping to ensure cleanliness.
4. Pipe unit using good piping practice (see ASHRAE handbook section 215 and 195).
5. Check to see that the unit is installed and operated within limitations (Refer to LIMITATIONS).

The following pages outline detailed procedures to be followed to install and start-up the chiller.

HANDLING

These units are shipped as completely assembled units containing full operating charge, and care should be taken to avoid damage due to rough handling.

INSPECTION

Immediately upon receiving the unit, it should be inspected for possible damage which may have occurred during transit. If damage is evident, it should be noted in the carrier's freight bill. A written request for inspection by the carrier's agent should be made at once. See "Instruction" manual, Form 50.15-NM for more information and details.

LOCATION AND CLEARANCES

These units are designed for outdoor installations on ground level, rooftop, or beside a building. Location should be selected for minimum sun exposure and to insure adequate supply of fresh air for the condenser. The units must be installed with sufficient clearances for air entrance to the condenser coil, for air discharge away from the condenser, and for servicing access.

In installations where winter operation is intended and snow accumulations are expected, additional height must be provided to ensure normal condenser air flow.

Clearances are listed on Figure 30.

Foundation

The unit should be mounted on a flat and level foundation, floor, or rooftop capable of supporting the entire operating weight of the equipment. See "Physical Data" for operating weight. If the unit is elevated beyond the normal reach of service personnel, a suitable catwalk must be capable of supporting service personnel, their equipment, and the compressors.

Ground Level Locations

It is important that the units be installed on a substantial base that will not settle. A one piece concrete slab with footers extended below the frost line is highly recommended. Additionally, the slab should not be tied to the main building foundations as noise and vibration may be transmitted. Mounting holes are provided in the steel channel for bolting the unit to its foundation (see Section 5 "Dimensions").

For ground level installations, precautions should be taken to protect the unit from tampering by or injury to unauthorized persons. Screws and/or latches on access panels will prevent casual tampering. However, further safety precautions such as a fenced-in enclosure or locking devices on the panels may be advisable.

Roftop Locations

Choose a spot with adequate structural strength to safely support the entire weight of the unit and service personnel. Care must be taken not to damage the roof.

Consult the building contractor or architect if the roof is bonded. Roof installations should have wooden beams (treated to reduce deterioration), cork, rubber, or vibration isolators under the base to minimize vibration.

Noise Sensitive Locations

Efforts should be made to assure that the chiller is not located next to occupied spaces or noise sensitive areas where chiller noise level would be a problem. Chiller noise is a result of compressor and fan operation. Considerations should be made utilizing noise levels published in the YORK Engineering Guide for the specific chiller model. Sound blankets for the compressors and low sound fans are available.

SPRING ISOLATORS (OPTIONAL)

When ordered, four (4) isolators will be furnished.

Identify the isolator, locate at the proper mounting point, and adjust per instructions.

COMPRESSOR MOUNTING

The compressors are mounted on four (4) rubber isolators. The mounting bolts should not be loosened or adjusted at installation of the chiller.

REMOTE COOLER OPTION

Not available at this time.

CHILLED LIQUID PIPING

When the unit(s) has been located in its final position, the unit water piping may be connected. Normal installation precautions should be observed in order to receive maximum operating efficiencies. Piping should be kept free of all foreign matter. All chilled water evaporator piping must comply in all respects with local plumbing codes and ordinances.

Since elbows, tees and valves decrease pump capacity, all piping should be kept as straight and as simple as possible. **All piping must be supported independent of the chiller.**

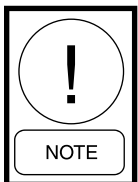

Consideration should be given to compressor access when laying out water piping. Routing the water piping too close to the unit could make compressor servicing/replacement difficult.

Hand stop valves should be installed in all lines to facilitate servicing.

Piping to the inlet and outlet connections of the chiller should include high-pressure rubber hose or piping loops to ensure against transmission of water pump vibration. The necessary components must be obtained in the field.

Drain connections should be provided at all low points to permit complete drainage of the cooler and system water piping.

A small valve or valves should be installed at the highest point or points in the chilled water piping to allow any trapped air to be purged. Vent and drain connections should be extended beyond the insulation to make them accessible.

The piping to and from the cooler must be designed to suit the individual installation. It is important that the following considerations be observed:

1. The chilled liquid piping system should be laid out so that the circulating pump discharges directly into the cooler. The suction for this pump should be taken from the piping system return line and not the cooler. This piping scheme is recommended, but is not mandatory.
2. The inlet and outlet cooler connection sizes are 3" (YCAL0043 to YCAL0066).
3. A strainer, preferably 40 mesh, **must** be installed in the cooler inlet line just ahead of the cooler. This is important to protect the cooler from entrance of large particles which could cause damage to the evaporator.
4. All chilled liquid piping should be thoroughly flushed to free it from foreign material before the system is placed into operation. Use care not to flush any foreign material into or through the cooler.
5. As an aid to servicing, thermometers and pressure gauges should be installed in the inlet and outlet water lines.
6. The chilled water lines that are exposed to outdoor ambients should be wrapped with supplemental heater cable and insulated to protect against freeze-up during low ambient periods, and to prevent formation of condensation on lines in warm humid locations.
7. A chilled water flow switch, (either by YORK or others) **must** be installed in the leaving water piping of the cooler. There should be a straight horizontal run of at least 5 diameters on each side of the switch. Adjust the flow switch paddle to the

size of the pipe in which it is to be installed (see manufacturer's instructions furnished with the switch). The switch is to be wired to terminals 13 and 14 of CTB1 located in the control panel, as shown on the unit wiring diagram.



The flow switch MUST NOT be used to start and stop the chiller (i.e. starting and stopping the chilled water pump). It is intended only as a safety switch.

PIPEWORK ARRANGEMENT

The following are suggested pipework arrangements for single unit installations, for multiple unit installations, each unit should be piped as shown.

Recommendations of the Building Services Research Association.

DUCT WORK CONNECTION

General Requirements

The following duct work recommendations are intended to ensure satisfactory operation of the unit. Failure

to follow these recommendations could cause damage to the unit, or loss of performance, and may invalidate the warranty.

When ducting is to be fitted to the fan discharge it is recommended that the duct should be the same cross-sectional area as the fan outlet and straight for at least three feet (1 meter) to obtain static regain from the fan. Duct work should be suspended with flexible hangers to prevent noise and vibration being transmitted to the structure. A flexible joint is also recommended between the duct attached to the fan and the next section for the same reason. Flexible connectors should not be allowed to concertina.

The unit(s) is not designed to take structural loading. No significant amount of weight should be allowed to rest on the fan outlet flange, deck assemblies or condenser coil module. No more than 3 feet (1 meter) of light construction duct work should be supported by the unit. Where cross winds may occur, any duct work must be supported to prevent side loading on the unit.

If the ducts from two or more fans are to be combined into a common duct, back-flow dampers should be fitted in the individual fan ducts. This will prevent recirculation of air when only one of the fans is running.

Units are supplied with outlet guards for safety and to prevent damage to the fan blades. If these guards are removed to fit duct work, adequate alternative precautions must be taken to ensure persons cannot be harmed or put at risk from rotating fan blades.

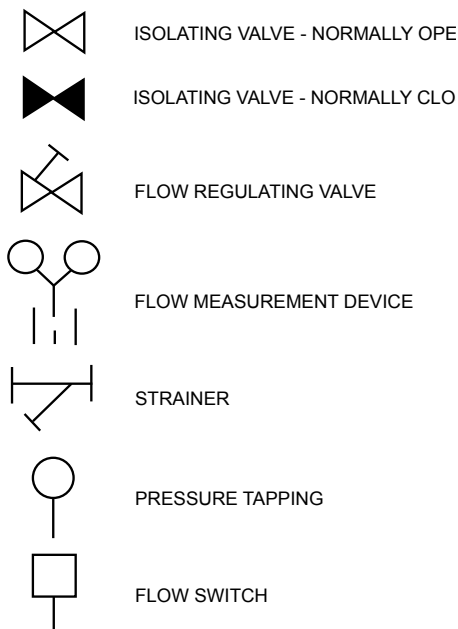
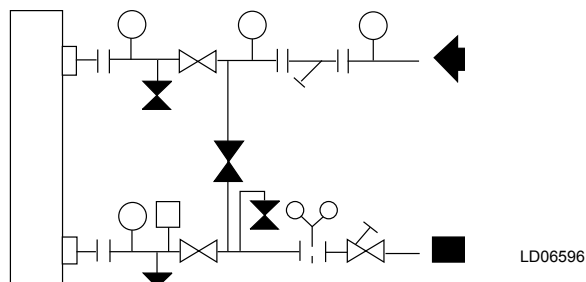

LD06596

LD06597A

FIGURE 9 - CHILLED LIQUID SYSTEM

WIRING

Liquid Chillers are shipped with all factory-mounted controls wired for operation.

Field Wiring

Power wiring must be provided through a fused disconnect switch to the unit terminals (or optional molded disconnect switch) in accordance with N.E.C. or local code requirements. Minimum circuit ampacity and maximum dual element fuse size are given in Table 7.

Copper power wiring only should be used for supplying power to the chiller. This is recommended to avoid safety and reliability issues resulting from connection failure at the power connections to the chiller. Aluminum wiring is not recommended due to thermal characteristics that may cause loose terminations resulting from the contraction and expansion of the wiring. Aluminum oxide may also build up at the termination causing hot spots and eventual failure. If aluminum wiring is used to supply power to the chiller, AL-CU compression fittings should be used to transition from

aluminum to copper. This transition should be done in an external box separate to the power panel. Copper conductors can then be run from the box to the chiller.

A 120-1-60, 15 amp source must be supplied for the control panel through a fused disconnect when a control panel transformer (optional) is not provided (Refer to Figure 10).

See unit wiring diagrams for field and power wiring connections, chilled water pump starter contacts, alarm contacts, compressor run status contacts, PWM input, and load limit input. Refer to Section 8 “Unit Operation” for a detailed description of operation concerning aforementioned contacts and inputs.

Evaporator Pump Start Contacts

Terminal block TB1 terminals 23 to 24, are normally-open contacts that can be used to switch field supplied power to provide a start signal to the evaporator pump contactor. The contacts will be closed when any of the following conditions occur:

1. Low Leaving Chilled Liquid Fault
2. Any compressor is running
3. Daily schedule is not programmed OFF and the Unit Switch is ON

The pump will not run if the micro panel has been powered up for less than 30 seconds, or if the pump has run in the last 30 seconds, to prevent pump motor overheating. Refer to Figure 11 and unit wiring diagram.

System Run Contacts

Contacts are available to monitor system status. Normally-open auxiliary contacts from each compressor contactor are wired in parallel with TB1 terminals 25 to 26 for system 1, and TB1 terminals 27 to 28 for system 2 (YCAL0043 to YCAL0066). Refer to Figure 5, 11 and unit wiring diagram.

Alarm Status Contacts

Normally-open contacts are available for each refrigerant system. These normally-open contacts close when the system is functioning normally. The respective contacts will open when the unit is shut down on a unit fault, or locked out on a system fault. Field connections are at TB1 terminals 29 to 30 (system 1), and terminals 31 to 32 (system 2 YCAL0043 to YCAL0066).

Remote Start/Stop Contacts

To remotely start and stop the chiller, dry contacts can be wired in series with the flow switch and CTB1 terminals 13 to 14. Refer to Figure 5, 11 and unit wiring diagram.

Remote Emergency Cutoff

Immediate shutdown of the chiller can be accomplished by opening a field-installed dry contact to break the electrical circuit between terminals 5 to L on terminal block TB1. The unit is shipped with a factory jumper installed between terminals 5 to L, which must be removed if emergency shutdown contacts are installed. Refer to Figure 11 and unit wiring diagram.

Remote Temp Reset Input

The Remote Temp Reset input allows reset of the chilled liquid setpoint by supplying a voltage or current signal field wiring should be connected to CTB1 terminals A+ to A-. A detailed explanation is provided in the Unit Control section. Refer to Figure's. 3 and 5 and unit wiring diagram.

Load Limit Input

Load limiting is a feature that prevents the unit from loading beyond a desired value. The unit can be “load limited” either 33%, 40%, 50%, 66% or 80%, depending on the number of compressors on unit. The field connections are wired to CTB1 terminals 13 to 21, and work in conjunction with the PWM inputs. A detailed explanation is provided in the Unit Control section. Refer to Figure 5, 11 and unit wiring diagram.

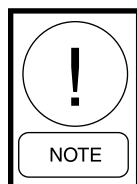

When using the Load Limit feature, the PWM feature will not function – SIMULTANEOUS OPERATION OF LOAD LIMITING AND TEMPERATURE RESET (PWM INPUT) CANNOT BE DONE.

Flow Switch Input

The flow switch is field wired to CTB1 terminals 13 and 14. See Figure 4 and the unit wiring diagram.

COMPRESSOR HEATERS

Compressor heaters are standard. Non-standard applications are as follows:

- ZP103, ZP120 and ZP137 compressors utilize 90W heaters
- ZP180 compressors utilize 70W heaters
- ZP235 compressors utilize 120W heaters

If power is OFF more than two hours, the crankcase heaters must be energized for between 18 and 24 hours

prior to restarting a compressor. This will assure that liquid slugging and oil dilution does not damage the compressors on start.

RELIEF VALVES

Relief valves are located on both the high and low pressure side of the piping. High side relief valve pressure setting is 650 PSIG. Low side relief valve pressure setting is 450 PSIG.

HIGH PRESSURE CUTOUT

A high pressure cutout is installed in the discharge piping of each system. The cutout opens at 585 PSIG plus or minus 10 PSIG and closes at 440 PSIG plus or minus 25 PSIG.

SINGLE-POINT SUPPLY CONNECTION – TERMINAL BLOCK, NON-FUSED DISCONNECT SWITCH OR CIRCUIT BREAKER

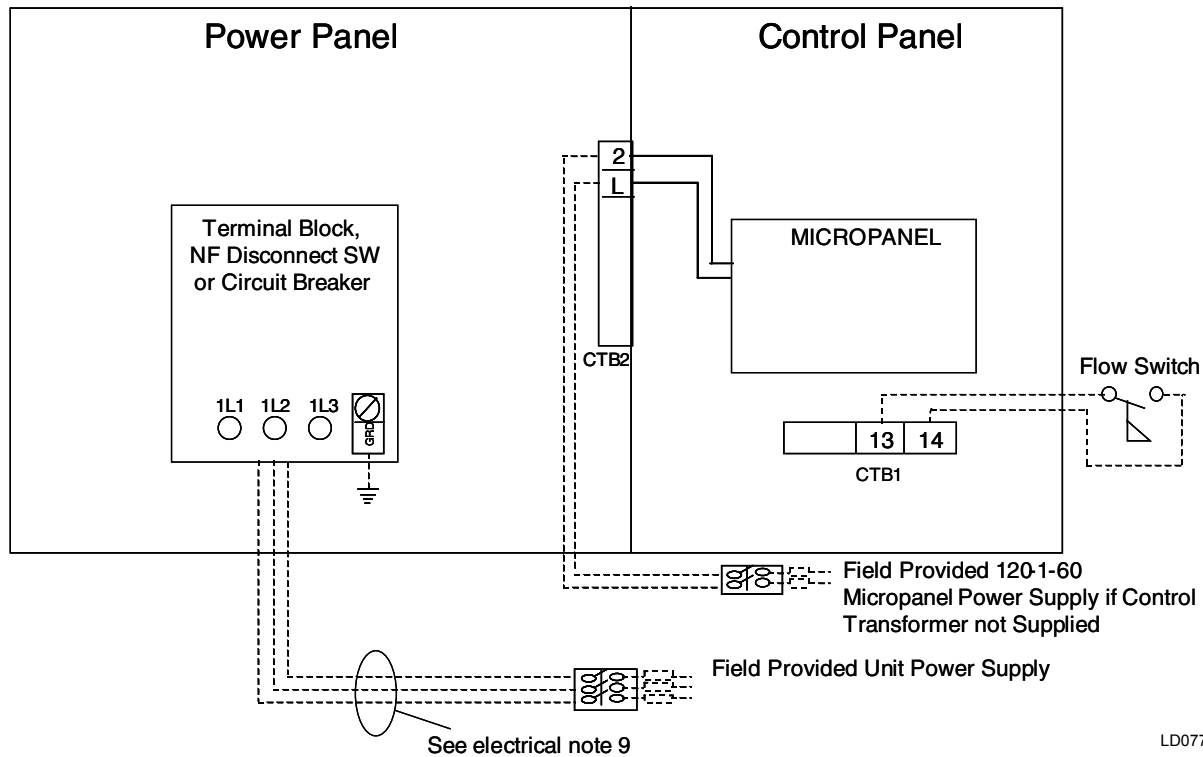

Electrical Notes and Legend located on Page 59.



*It is possible that multiple sources of power can be supplying the unit power panel. To prevent serious injury or death, the technician should verify that **NO LETHAL VOLTAGES** are present inside the panel **AFTER** disconnecting power, **PRIOR** to working on equipment.*



The unit evaporator heater uses 120VAC. Disconnecting 120VAC power from the unit, at or below freezing temperatures, can result in damage to the evaporator and unit as a result of the chilled liquid freezing.

FIGURE 10 - SINGLE-POINT SUPPLY CONNECTION – TERMINAL BLOCK, NON-FUSED DISCONNECT SWITCH OR CIRCUIT BREAKER (0043 – 0066)

CONTROL WIRING

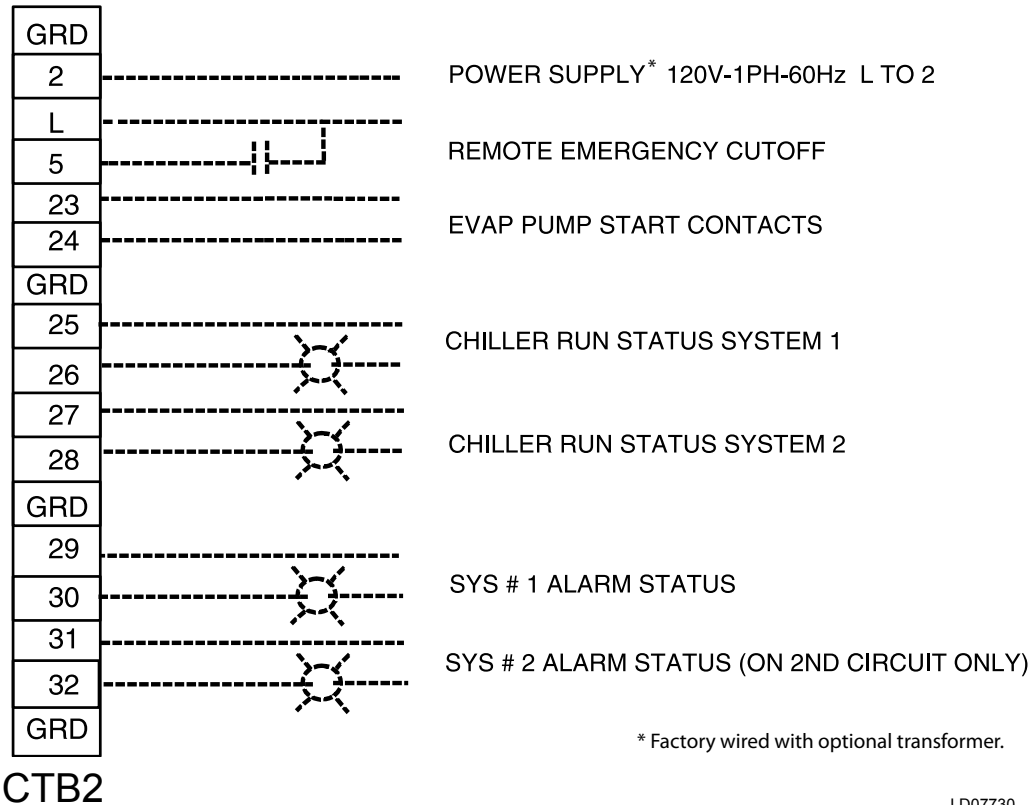
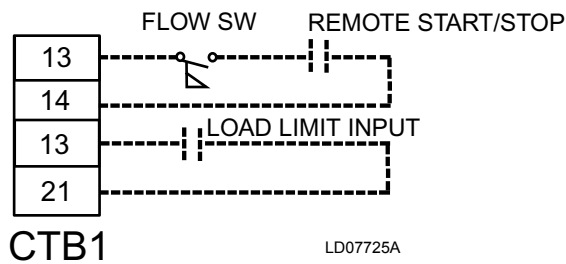

*It is possible that multiple sources of power can be supplying the unit power panel. To prevent serious injury or death, the technician should verify that **NO LETHAL VOLTAGES** are present inside the panel **AFTER** disconnecting power, **PRIOR** to working on equipment.*

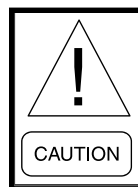

The unit evaporator heater uses 120VAC. Disconnecting 120VAC power from the unit, at or below freezing temperatures, can result in damage to the evaporator and unit as a result of the chilled liquid freezing.

FIGURE 11 - CONTROL WIRING

THIS PAGE INTENTIONALLY LEFT BLANK

SECTION 5 – TECHNICAL DATA

OPERATIONAL LIMITATIONS (ENGLISH)

TABLE 1 - TEMPERATURES AND FLOWS

ENGLISH						
YCAL	LEAVING WATER TEMPERATURE (°F)		COOLER FLOW (GPM)		AIR ON CONDENSER (°F)	
	MINIMUM	MAXIMUM	MINIMUM	MAXIMUM	MINIMUM	MAXIMUM
0019	40	55	17	68	0	125
0022	40	55	21	84	0	125
0028	40	55	30	150	0	125
0033	40	55	34	150	0	125
0043	40	55	40	200	0	125
0046	40	55	40	200	0	125
0052	40	55	40	300	0	125
0056	40	55	60	300	0	125
0066	40	55	60	300	0	125

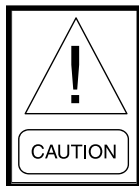

Excessive flow will cause damage to the cooler. Do not exceed max. cooler flow. Special care should be taken when multiple chillers are fed by a single pump.

5**NOTES:**

- For leaving brine temperature below 40 °F (4.4 °C), contact your nearest Johnson Controls Office for application requirements.
- For leaving water temperature higher than 55 °F (12.8 °C), contact the nearest Johnson Controls Office for application guidelines.
- The evaporator is protected against freezing to -20 °F (-28.8 °C) with an electric heater as standard.
- For operation at temperatures below 25 °F (-3.9 °C), the optional Low Ambient Kit will need to be installed on the system (for YCAL0043 to YCAL0065).
- For operation at temperatures above 115 °F (46.1 °C), the optional High Ambient Kit will need to be installed on the system.

Voltage Limitations

The following voltage limitations are absolute and operation beyond these limitations may cause serious damage to the compressor.

TABLE 2 - VOLTAGE LIMITATIONS

UNIT POWER	MINIMUM	MAXIMUM
200-3-60	180	220
230-3-60	207	253
380-3-60	355	415
460-3-60	414	506
575-3-60	517	633

YCAL0043-0066 HEAT EXCHANGER FLOW, GPM

ENGLISH

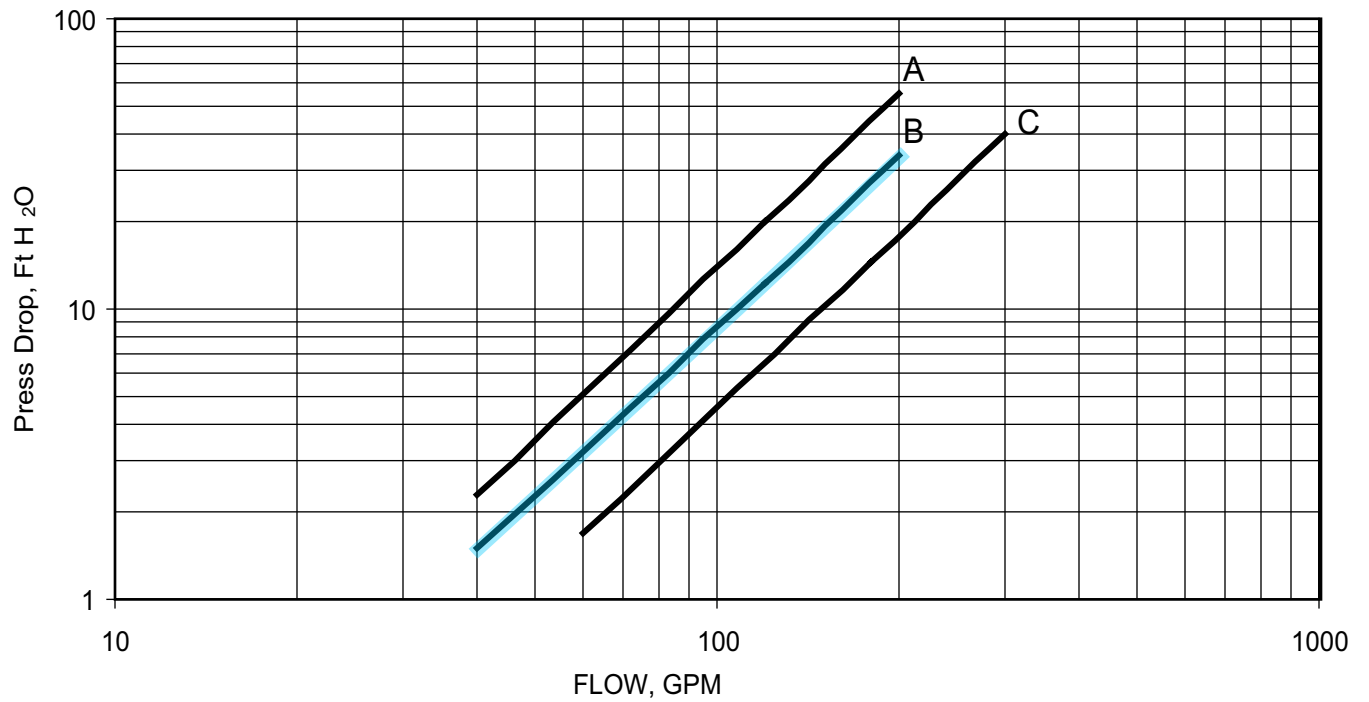

5

LD12451

YCAL	COOLER CURVE
0043	A
0046	B
0052	B
0056	C
0066	C

Note: Water Pressure Drop Curves may extend past the minimum and maximum water flow ranges.

PHYSICAL DATA (ENGLISH)

YCAL0019_ – YCAL0066_

60Hz

TABLE 6 - PHYSICAL DATA (ENGLISH)

Model No. YCAL		0019	0022	0028	0033	0043	0046	0052	0056	0066	
Length		109.8	109.8	118.6	118.6	144.8	144.8	148.8	148.8	153.6	
Width		44.7	44.7	44.7	44.7	90.6	90.6	90.6	90.6	90.6	
Height		46.1	46.1	50	50	47.8	47.8	62.6	62.6	62.6	
Nominal Tons		14.5	17.8	24.3	28	34.9	38	45.2	45.2	60.1	
Number of Refrigerant Circuits		1	1	1	1	2	2	2	2	2	
Refrig. Chg, Opt, R-410A (lbs) ckt1/ckt2		25	30	45	50	35/35	40/35	45/45	50/50	65/65	
Oil Charge, gallons ckt1/ckt2		1.8	1.8	1.7	2.2	1.8/1.8	1.8/1.8	1.7/1.7	1.7/1.7	2.3/2.2	
Shipping Weight	Alum. Fin Coils, lbs	1454	1567	1799	2034	2942	2968	3196	3208	4097	
	Copper Fin Coils, lbs	1597	1781	2005	2240	3300	3326	3673	3685	4703	
Operating Weight	Alum. Fin Coils, lbs	1481	1597	1829	2077	2967	3001	3233	3245	4142	
	Copper Fin Coils, lbs	1624	1811	2035	2283	3325	3359	3710	3722	4748	
Nominal Comp. Capacity	Comp. 1	8	10	15	15	10	12	13	15	20	
	Comp. 2	8	10	13	15	10	12	13	15	20	
	Comp. 3	–	–	–	–	–	–	–	–	–	
	Comp. 4	–	–	–	–	10	10	13	15	15	
	Comp. 5	–	–	–	–	10	10	13	15	15	
	Comp. 6	–	–	–	–	–	–	–	–	–	
Condenser	Total Face Area ft ²		34.7	34.7	43.5	43.5	87	87	116	116	128
	Number of Rows Deep	Ckt. 1	2	3	3	3	2	2	3	3	3
		Ckt. 2	X	X	X	X	2	2	3	3	3
	Fins per Inch		17	17	13	13	17	17	17	17	13
Condenser Fans, Low Sound	Number of Fans	Ckt. 1	2	2	2	2	2	2	2	2	
		Ckt. 2	X	X	X	X	2	2	2	2	2
	Fan Power hp/fan		0.3	0.3	1.2	1.2	1.2	1.2	1.2	1.2	1.2
	Fan RPM		920	920	950	950	950	950	950	950	950
	Total Chiller CFM		10833	10833	20000	20000	39500	39500	43333	43333	43333
Condenser Fans, Ultra Quiet	Number of Fans	Ckt. 1	2	2	2	2	2	2	2	2	
		Ckt. 2	X	X	X	X	2	2	2	2	2
	Fan Power hp/fan		N/A	N/A	1.2	1.2	1.2	1.2	1.2	1.2	1.2
	Fan RPM		N/A	N/A	698	698	698	698	698	698	698
Total Chiller CFM		N/A	N/A	20000	20000	39500	39500	43333	43333	43333	
Evaporator	Water Volume	Gallons	1.2	1.6	2.5	3.2	2.7	3.5	3.5	4.1	4.9
	Max Water Side Pressure	PSIG	300	300	300	300	300	300	300	300	300
	Max Refrig Side Pressure	PSIG	450	450	450	450	450	450	450	450	450
	Min. Chiller Water Flow	GPM	10	10	10	10	40	40	60	60	60
	Max. Chiller Water Flow	GPM	150	150	150	150	200	200	300	300	300
	Nom. Water Connections Size	Inches	2	2	2	2	3	3	3	3	3

ELECTRICAL DATA (ENGLISH)

YCAL0019_ – YCAL0066_ (Without Pump)

Single-Point Field Supplied Power Wiring (See Figure 8)
 (One Field Provided Power Supply to the chiller. Field connections to Factory Provided Power Terminal Block (standard), Non-Fused Disconnect Switch (optional) or Circuit Breaker (optional)).

*** This Data only applies to chillers Without Pump Packages**

TABLE 7 - ELECTRICAL DATA (ENGLISH)

MODEL YCAL	VOLT 60 Hz	MCA ¹	MIN N/F DISC MDSW ²	D.E. FUSE		CKT. BKR. ⁵		FIELD WIRING LUGS ⁶ TERMINAL BLOCK (std)		FIELD WIRING LUGS ⁶ NF DISC. SWITCH (opt)		FIELD WIRING LUGS ⁶ CIRCUIT BREAKER (opt)	
				MIN.	MAX ⁴	MIN.	MAX	LUGS/ PHASE	LUG WIRE RANGE	LUGS/ PHASE	LUG WIRE RANGE	LUGS/ PHASE	LUG WIRE RANGE
0019	200	101	150	125	125	125	125	1	14 AWG – 2/0	1	4 AWG – 300 kcmil	1	6 AWG – 350MCM
	230	94	100	110	125	110	125	1	14 AWG – 2/0	1	4 AWG – 300 kcmil	1	6 AWG – 350MCM
	380	54	60	60	70	60	70	1	14 AWG – 2/0	1	14 AWG – 1/0	1	14 AWG – 1/0
	460	45	60	50	60	50	60	1	14 AWG – 2/0	1	14 AWG – 1/0	1	14 AWG – 1/0
	575	36	60	40	50	40	50	1	14 AWG – 2/0	1	14 AWG – 1/0	1	14 AWG – 1/0
0022	200	108	150	125	150	125	150	1	14 AWG – 2/0	1	4 AWG – 300 kcmil	1	6 AWG – 350MCM
	230	100	150	125	125	125	125	1	14 AWG – 2/0	1	4 AWG – 300 kcmil	1	6 AWG – 350MCM
	380	58	60	70	80	70	80	1	14 AWG – 2/0	1	14 AWG – 1/0	1	14 AWG – 1/0
	460	48	60	60	60	60	60	1	14 AWG – 2/0	1	14 AWG – 1/0	1	14 AWG – 1/0
	575	39	60	45	50	45	50	1	14 AWG – 2/0	1	14 AWG – 1/0	1	14 AWG – 1/0
028	200	136	150	175	175	175	175	1	14 AWG – 2/0	1	4 AWG – 300 kcmil	1	6 AWG – 350MCM
	230	136	150	150	175	175	175	1	14 AWG – 2/0	1	4 AWG – 300 kcmil	1	6 AWG – 350MCM
	380	81	100	90	110	110	110	1	14 AWG – 2/0	1	14 AWG – 1/0	1	14 AWG – 1/0
	460	65	100	80	90	90	90	1	14 AWG – 2/0	1	14 AWG – 1/0	1	14 AWG – 1/0
	575	55	60	70	70	70	70	1	14 AWG – 2/0	1	14 AWG – 1/0	1	14 AWG – 1/0
0033	200	151	200	175	200	175	200	1	6 AWG – 350 kcmil	1	4 AWG – 300 kcmil	1	6 AWG – 350MCM
	230	140	150	175	175	175	175	1	6 AWG – 350 kcmil	1	4 AWG – 300 kcmil	1	6 AWG – 350MCM
	380	81	100	90	110	90	110	1	14 AWG – 2/0	1	14 AWG – 1/0	1	14 AWG – 1/0
	460	67	100	80	90	80	90	1	14 AWG – 2/0	1	14 AWG – 1/0	1	14 AWG – 1/0
	575	54	60	60	70	60	70	1	14 AWG – 2/0	1	14 AWG – 1/0	1	14 AWG – 1/0
0043	200	224	250	250	250	250	250	1	6 AWG – 350 kcmil	2	*(2) 3/0 – 250 kcmil	2	*(2) 3/0 – 250 kcmil
	230	209	250	225	250	225	250	1	6 AWG – 350 kcmil	2	*(2) 3/0 – 250 kcmil	2	*(2) 3/0 – 250 kcmil
	380	121	150	150	150	150	150	1	14 AWG – 2/0	1	4 AWG – 300 kcmil	1	6 AWG – 350MCM
	460	99	150	110	110	110	110	1	14 AWG – 2/0	1	4 AWG – 300 kcmil	1	6 AWG – 350MCM
	575	80	100	90	90	90	90	1	14 AWG – 2/0	1	4 AWG – 300 kcmil	1	6 AWG – 350MCM
0046	200	228	250	250	250	250	250	1	6 AWG – 350 kcmil	2	*(2) 3/0 – 250 kcmil	2	*(2) 3/0 – 250 kcmil
	230	212	250	225	250	225	250	1	6 AWG – 350 kcmil	2	*(2) 3/0 – 250 kcmil	2	*(2) 3/0 – 250 kcmil
	380	123	150	150	150	150	150	1	14 AWG – 2/0	1	4 AWG – 300 kcmil	1	6 AWG – 350MCM
	460	101	150	110	110	110	110	1	14 AWG – 2/0	1	4 AWG – 300 kcmil	1	6 AWG – 350MCM
	575	81	100	90	90	90	90	1	14 AWG – 2/0	1	4 AWG – 300 kcmil	1	6 AWG – 350MCM
0052	200	248	400	300	300	300	300	1	6 AWG – 350 kcmil	2	*(2) 3/0 – 250 kcmil	2	*(2) 3/0 – 250 kcmil
	230	248	400	300	300	300	300	1	6 AWG – 350 kcmil	2	*(2) 3/0 – 250 kcmil	2	*(2) 3/0 – 250 kcmil
	380	132	150	150	150	150	150	1	14 AWG – 2/0	1	4 AWG – 300 kcmil	1	6 AWG – 350MCM
	460	114	150	125	125	125	125	1	14 AWG – 2/0	1	4 AWG – 300 kcmil	1	6 AWG – 350MCM
	575	96	150	110	110	110	110	1	14 AWG – 2/0	1	4 AWG – 300 kcmil	1	6 AWG – 350MCM

ELECTRICAL DATA (ENGLISH) (CONT'D)

YCAL0019_ – YCAL0066_

Single-Point Field Supplied Power Wiring (See Figure 8)
 (One Field Provided Power Supply to the chiller. Field connections to Factory Provided Power Terminal Block (standard), Non-Fused Disconnect Switch (optional) or Circuit Breaker (optional)).

SYSTEM #1 COMPRESSOR & FAN							SYSTEM #2 COMPRESSOR & FAN						
COMPR. #1		COMPR. #2		FANS			COMPR. #1		COMPR. #2		FANS		
RLA	LRA	RLA	LRA	QTY	FLA	RLA	RLA	LRA	RLA	LRA	QTY	FLA	RLA
42.2	250	42.2	250	2	2.6	5.0	—	—	—	—	—	—	—
39.0	250	39.0	250	2	2.6	5.0	—	—	—	—	—	—	—
22.5	155	22.5	155	2	1.6	3.0	—	—	—	—	—	—	—
18.6	114	18.6	114	2	1.3	2.5	—	—	—	—	—	—	—
14.9	100	14.9	100	2	1.0	2.0	—	—	—	—	—	—	—
45.4	250	45.4	250	2	2.6	5.0	—	—	—	—	—	—	—
42.0	250	42.0	250	2	2.6	5.0	—	—	—	—	—	—	—
24.2	155	24.2	155	2	1.6	3.0	—	—	—	—	—	—	—
20.0	125	20.0	125	2	1.3	2.5	—	—	—	—	—	—	—
16.0	100	16.0	100	2	1.0	2.0	—	—	—	—	—	—	—
51.3	300	55.8	425	2	7.6	44.0	—	—	—	—	—	—	—
51.3	300	55.8	425	2	7.4	19.1	—	—	—	—	—	—	—
26.9	139	36.0	239	2	4.5	23.1	—	—	—	—	—	—	—
23.1	150	26.9	187	2	4.0	19.0	—	—	—	—	—	—	—
19.9	109	23.7	148	2	2.9	15.3	—	—	—	—	—	—	—
59.9	425	59.9	425	2	7.6	30.9	—	—	—	—	—	—	—
55.5	425	55.5	425	2	7.4	37.0	—	—	—	—	—	—	—
32.0	239	32.0	239	2	4.5	22.3	—	—	—	—	—	—	—
26.4	187	26.4	187	2	3.4	17.2	—	—	—	—	—	—	—
21.1	148	21.1	148	2	2.9	14.6	—	—	—	—	—	—	—
45.4	250	45.4	250	2	7.6	30.9	45.4	250	45.4	250	2	7.6	30.9
42.0	250	42.0	250	2	7.4	37.0	42.0	250	42.0	250	2	7.4	37.0
24.2	155	24.2	155	2	4.5	22.3	24.2	155	24.2	155	2	4.5	22.3
20.0	125	20.0	125	2	3.4	17.2	20.0	125	20.0	125	2	3.4	17.2
16.0	100	16.0	100	2	2.9	14.6	16.0	100	16.0	100	2	2.9	14.6
47.0	250	47.0	250	2	7.6	30.9	45.4	250	45.4	250	2	7.6	30.9
43.5	250	43.5	250	2	7.4	37.0	42.0	250	42.0	250	2	7.4	37.0
25.1	155	25.1	155	2	4.5	22.3	24.2	155	24.2	155	2	4.5	22.3
20.7	125	20.7	125	2	3.4	17.2	20.0	125	20.0	125	2	3.4	17.2
16.6	100	16.6	100	2	2.9	14.6	16.0	100	16.0	100	2	2.9	14.6
51.3	300	51.3	300	2	7.6	44.0	51.3	300	51.3	300	2	7.6	44.0
51.3	300	51.3	300	2	7.4	19.1	51.3	300	51.3	300	2	7.4	19.1
26.9	139	26.9	139	2	4.5	23.1	26.9	139	26.9	139	2	4.5	23.1
23.1	150	23.1	150	2	4.0	19.0	23.1	150	23.1	150	2	4.0	19.0
19.9	109	19.9	109	2	2.9	15.3	19.9	109	19.9	109	2	2.9	15.3

ELECTRICAL DATA

TABLE 8 - MICRO PANEL POWER SUPPLY

UNIT VOLTAGE	UNIT VOLTAGE	CONTROL POWER	MCA NOTE A	OVER CURRENT PROTECTION, SEE NOTE B		NF DISC SW
				MINIMUM	MAXIMUM	
MODELS W/O CONTROL TRANS		115-1-60/50	15A	10A	15A	30 A / 240V
MODELS W/ CONTROL TRANS	-17	200-1-60	15A	10A	15A	30 A / 240V
	-28	230-1-60	15A	10A	15A	30 A / 240V
	-40	380-1-60	15A	10A	15A	30 A / 480V
	-46	460-1-60	15A	10A	15A	30 A / 480V
	-50	380/415-1-60	15A	10A	15A	30A / 415V
	-58	575-1-60	15A	10A	15A	30 A / 600V

A. Minimum #14 AWG, 75 °C, Copper Recommended

B. Minimum and Maximum Over Current Protection, Dual Element Fuse or Circuit Breaker



It is possible that multiple sources of power can be supplying the unit power panel. To prevent serious injury or death, the technician should verify that NO LETHAL VOLTAGES are present inside the panel AFTER disconnecting power, PRIOR to working on equipment.



The unit evaporator heater uses 120VAC. Disconnecting 120VAC power from the unit, at or below freezing temperatures, can result in damage to the evaporator and unit as a result of the chilled liquid freezing.

TABLE 9 - VOLTAGE RANGE

VOLTAGE RANGE			
VOLTAGE CODE	UNIT POWER	MINIMUM	MAXIMUM
-17	200-3-60	180	220
-28	230-3-60	207	253
-40	380/415-3-60	342	440
-46	460-3-60	414	506
-50	380/415-3-50	342	440
-58	575-3-60	517	633

ELECTRICAL NOTES AND LEGEND

NOTES:

1. Minimum Circuit Ampacity (MCA) is based on 125% of the rated load amps for the largest motor plus 100% of the rated load amps for all other loads included in the circuit, per N.E.C. Article 430-24. If the optional Factory Mounted Control Transformer is provided, add the following MCA values to the electrical tables for the system providing power to the transformer: -17, add 2.5 amps; -28, add 2.3 amps; -40, add 1.5 amps, -46, add 1.3 amps; -58, add 1 amp.
2. The minimum recommended disconnect switch is based on 115% of the rated load amps for all loads included in the circuit, per N.E.C. Article 440.
3. Minimum fuse size is based upon 150% of the rated load amps for the largest motor plus 100% of the rated load amps for all other loads included in the circuit to avoid nuisance trips at start-up due to lock rotor amps. It is not recommended in applications where brown outs, frequent starting and stopping of the unit, and/or operation at ambient temperatures in excess of 95°F (35°C) is anticipated.
4. Maximum fuse size is based upon 225% of the rated load amps for the largest motor plus 100% of the rated load amps for all other loads included in the circuit, per N.E.C. Article 440-22.
5. Circuit breakers must be UL listed and CSA certified and maximum size is based on 225% of the rated load amps for the largest motor plus 100% of the rated load amps for all other loads included in the circuit. Otherwise, an HACR-type circuit breakers must be used. Maximum HACR circuit breaker rating is based on 225% of the rated load amps for the largest motor plus 100% of the rated load amps for all other loads included in the circuit.
6. The “Incoming Wire Range” is the minimum and maximum wire size that can be accommodated by the unit wiring lugs. The (2) preceding the wire range indicates the number of termination points available per phase of the wire range specified. Actual wire size and number of wires per phase must be determined based on the National Electrical Code, **using copper connectors only**. Field wiring must also comply with local codes.
7. A ground lug is provided for each compressor system to accommodate a field grounding conductor per N.E.C. Table 250-95. A control circuit grounding lug is also supplied.
8. The supplied disconnect is a “Disconnecting Means” as defined in the N.E.C. 100, and is intended for isolating the unit for the available power supply to perform maintenance and troubleshooting. This disconnect is not intended to be a Load Break Device.
9. Field wiring by others which complies with the National Electrical Code and Local Codes.

LEGEND:

ACR	ACROSS THE LINE START
C.B.	CIRCUIT BREAKER
D.E.	DUAL ELEMENT FUSE
DISC SW	DISCONNECT SWITCH
FACT MOUNT CB	FACTORY MOUNTED CIRCUIT BREAKER
FLA	FULL LOAD AMPS
HZ	HERTZ
MAX	MAXIMUM
MCA	MINIMUM CIRCUIT AMPACITY
MIN	MINIMUM
MIN	MINIMUM NON FUSED
RLA	RATED LOAD AMPS
S.P. WIRE	Single-Point WIRING
UNIT MTD SERV SW	UNIT MOUNTED SERVICE (NON-FUSED DISCONNECT SWITCH)
LRA	LOCKED ROTOR AMPS

VOLTAGE CODE
-17 = 200-3-60
-28 = 230-3-60
-40 = 380-3-60
-46 = 460-3-60
-58 = 575-3-60

LEGEND:

Field Wiring — — — —
 Factory Wiring —————

YCAL0043-YCAL0052 LOW SOUND

YCAL0043-YCAL0052 ULTRA LOW SOUND (460V AND 380-415V 50 HZ)

035-21447-401 REV -

**ELEMENTARY DIAGRAM
CONTROL CIRCUIT**

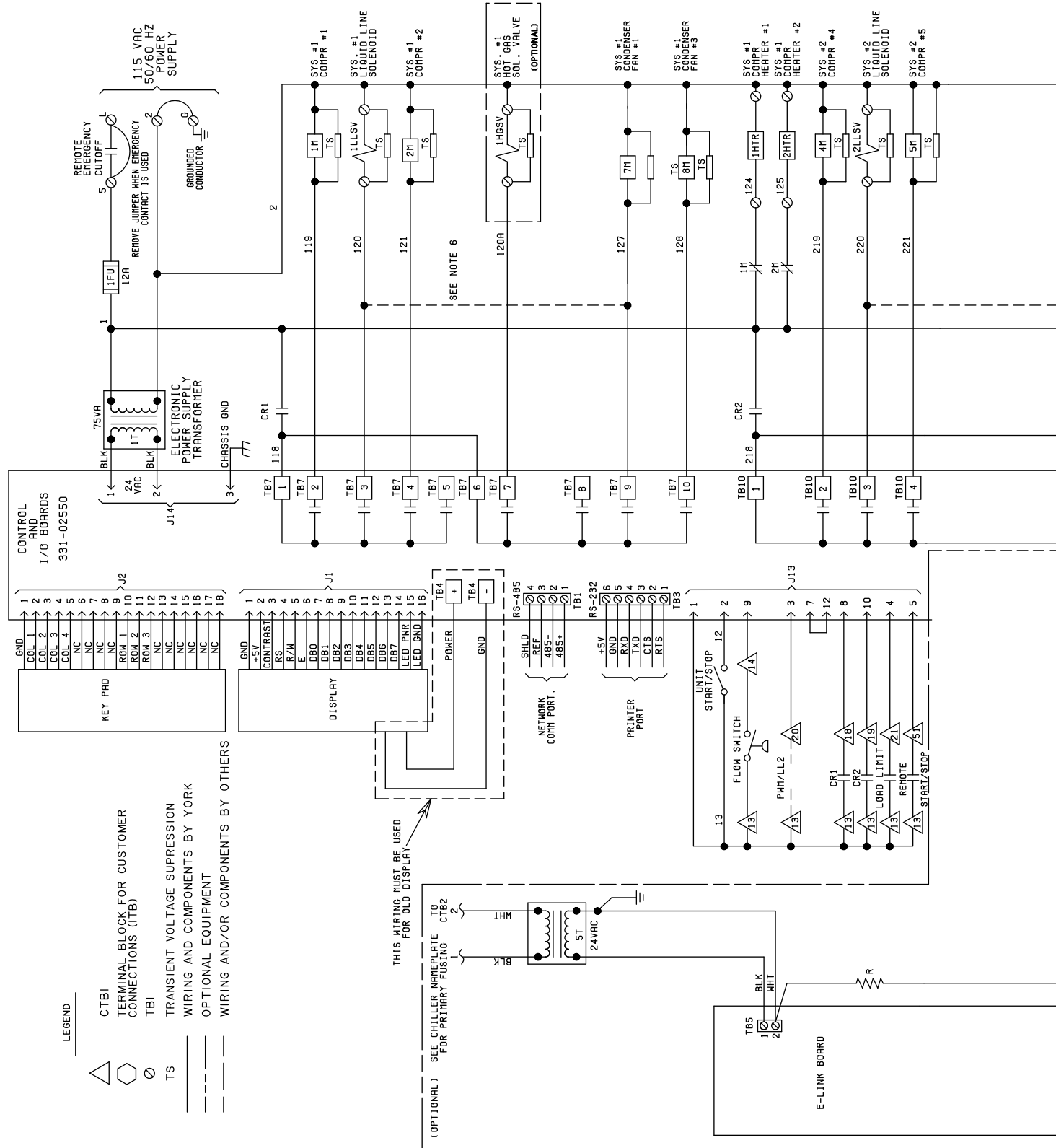

- LEGEND**
- CTBI
 - TERMINAL BLOCK FOR CUSTOMER CONNECTIONS (T8)
 - T81
 - TRANSIENT VOLTAGE SUPPRESSION
 - WIRING AND COMPONENTS BY YORK
 - OPTIONAL EQUIPMENT
 - WIRING AND/OR COMPONENTS BY OTHERS
- TS
 TS
 TS

THIS WIRING MUST BE USED FOR OLD DISPLAY

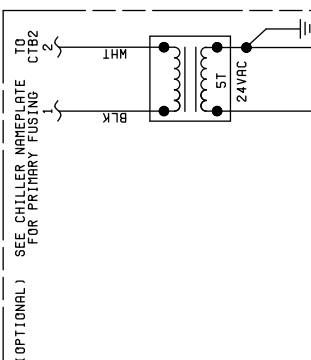
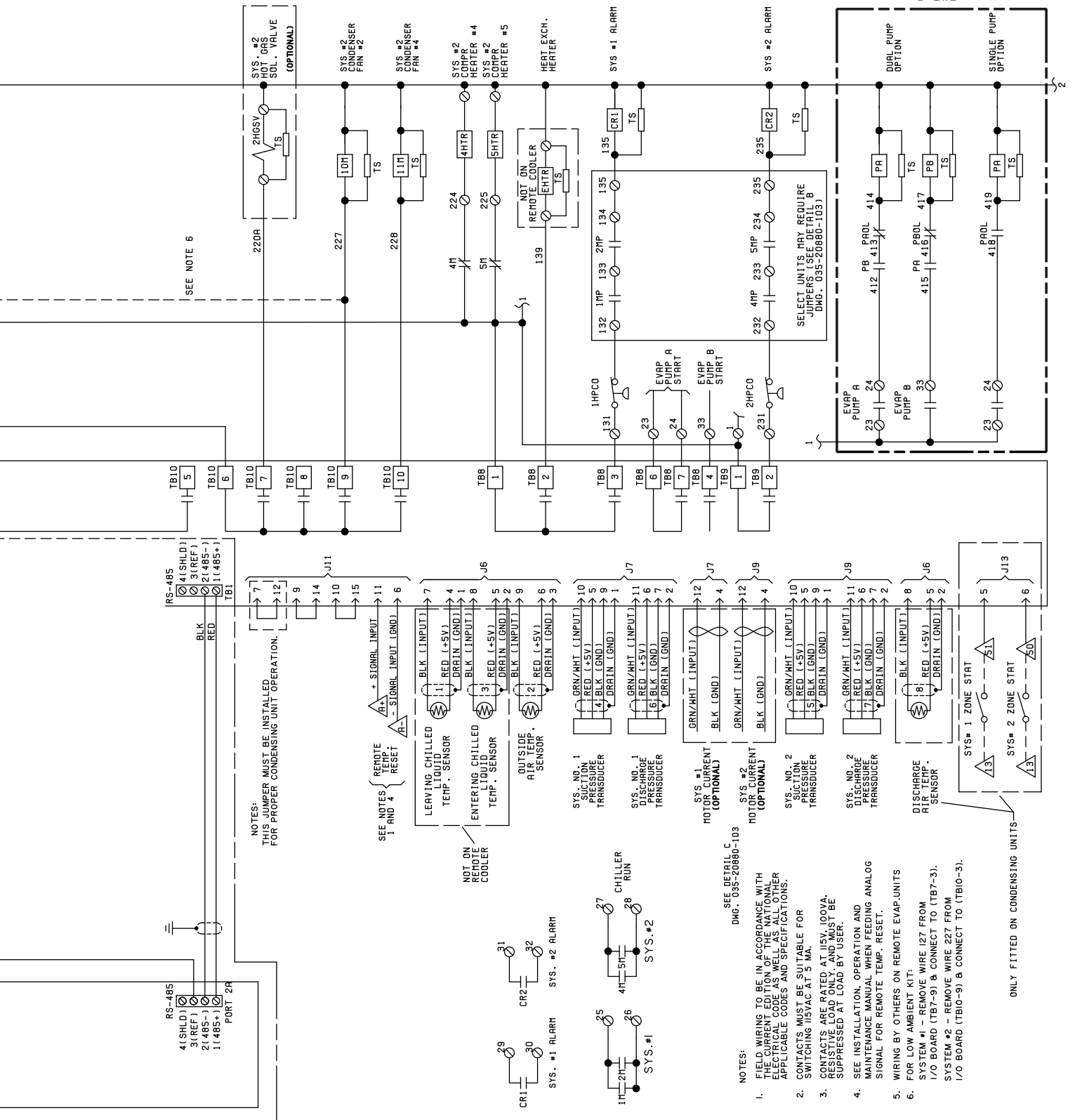

FIGURE 14 - CONTROL WIRING DIAGRAM, DUAL CIRCUIT, IPU II



SEE NOTE 6

NOTES:
THIS JUMPER MUST BE INSTALLED FOR PROPER CONDENSING UNIT OPERATION.

SEE NOTES { REMOTE TEMP RESET 1 AND 4 } + SIGNAL INPUT - SIGNAL INPUT (GND) 6

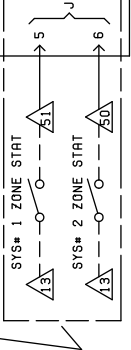
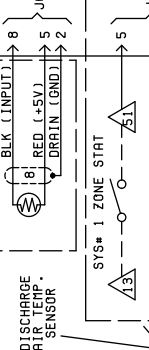
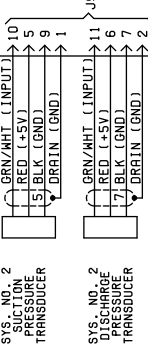
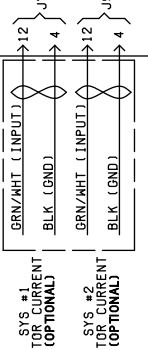
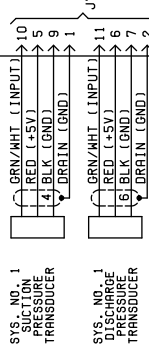
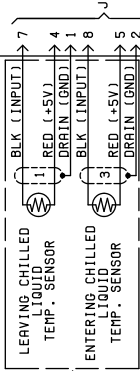

SEE DETAIL C DMG. 035-20880-103

- FIELD WIRING TO BE IN ACCORDANCE WITH THE CURRENT EDITION OF THE NATIONAL ELECTRICAL CODE AND SPECIFICATIONS.
- CONTACTS MUST BE SUITABLE FOR SWITCHING 115VAC AT 5 MA.
- CONTACTS ARE RATED AT 115VAC/5MA. CONTACTS MUST NOT BE SUPPRESSED AT LOAD BY USER.
- SEE INSTALLATION, OPERATION AND MAINTENANCE MANUAL WHEN FEEDING ANALOG SIGNAL FOR REMOTE TEMP. RESET.
- WIRING BY OTHERS ON REMOTE EVAP. UNITS
- FOR LOW AMBIENT KIT:
SYSTEM #1 - REMOVE WIRE I27 FROM I/O BOARD (I67-5) & CONNECT TO (I67-3).
SYSTEM #2 - REMOVE WIRE I27 FROM I/O BOARD (I610-9) & CONNECT TO (I610-3).

ONLY FITTED ON CONDENSING UNITS

OPTIONAL PUMP PACKAGE (DUAL & SINGLE PUMP SHOWN) - 102 FOR POWER WIRING

YCAL0043-YCAL0052 LOW SOUND
YCAL0043-YCAL0052 ULTRA LOW SOUND

DETAIL "A"

035-20880-103 REV C

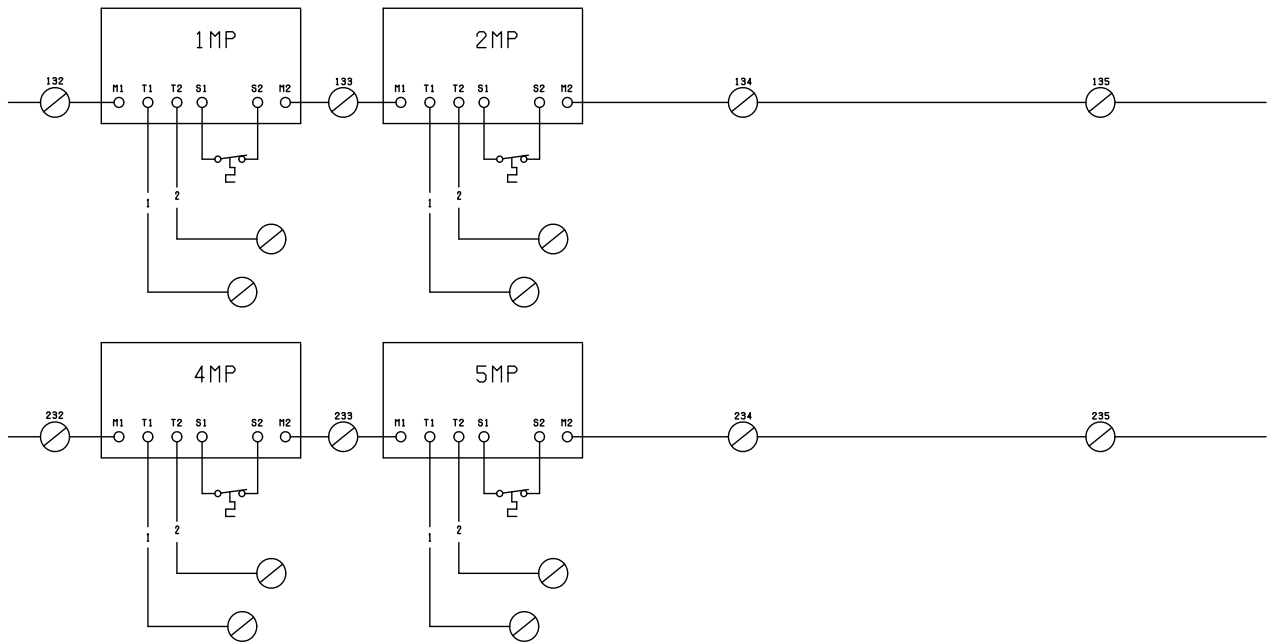





Notes:

1. Field wiring to be in accordance with the current edition of the National Electrical Code as well as all other applicable codes and specifications.
2. Contacts must be suitable for switching 24VDC, (gold contacts recommended). Wiring shall not be run in the same conduit with any line voltage (class 1) wiring.
3. To cycle unit ON and OFF automatically with contact shown, install a cycling device in series with the flow switch. See note 2 for contact rating and wiring specifications.
4. To stop unit (emergency stop) with contacts other than those shown, install the stop contact between terminals 5 and 1. If a stop device is not installed, a jumper must be connected between terminals 5 and 1. Device must have a minimum contact rating of 6A at 115VAC.
5. Contacts are rated at 115V, 100VA, resistive load only, and must be suppressed at load by user.
6. See installation, operation and maintenance manual when optional equipment is used.
7. Optional current readout. 5V = 200A.
8. 1MP thru 6MP are contained in their respective compressor junction boxes.

FIGURE 17 - CONTROL WIRING DIAGRAM, DETAILS, DUAL CIRCUIT

LEGEND

- TS TRANSIENT VOLTAGE SUPPRESSION
-  TERMINAL BLOCK FOR CUSTOMER LOW VOLTAGE (CLASS 2) CONNECTIONS. SEE NOTE 2.
-  TERMINAL BLOCK FOR YORK AND CUSTOMER CONNECTIONS
-  WIRING AND COMPONENTS BY YORK
-  OPTIONAL EQUIPMENT
-  WIRING AND/OR COMPONENTS BY OTHERS

DETAIL "B"

TYPICAL FOR INTERNALLY PROTECTED MOTORS

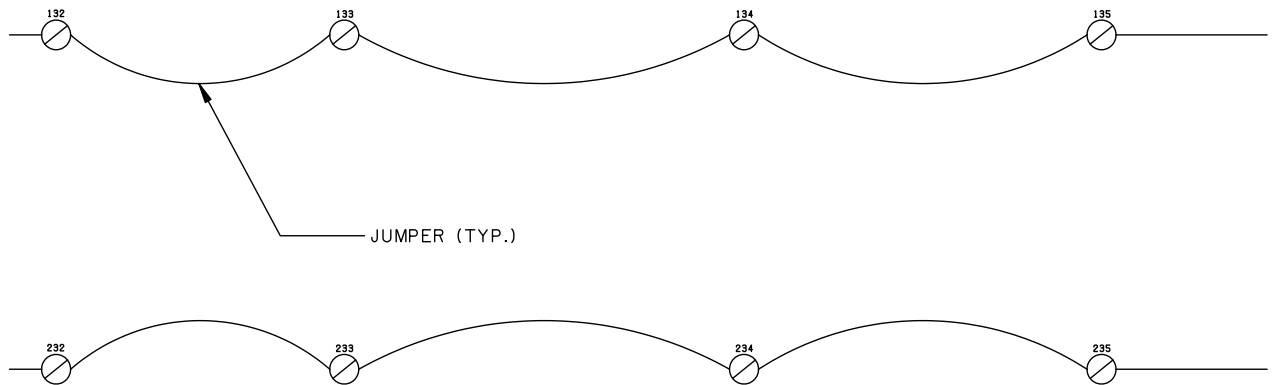

DETAIL "C"

OPTIONAL MOTOR CURRENT READOUT

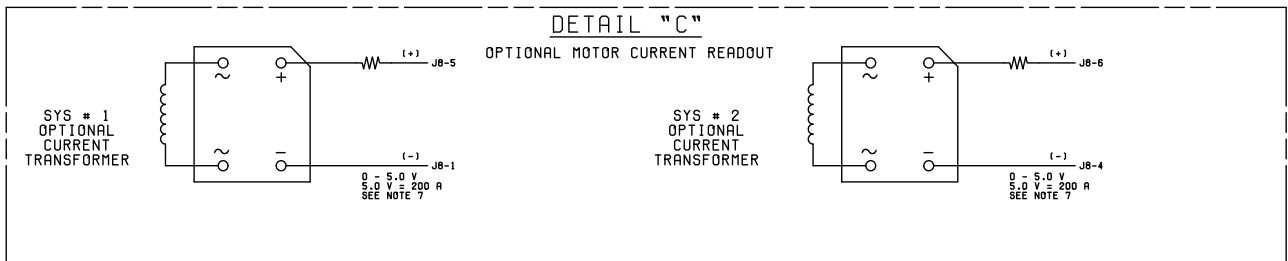

YCAL0043-YCAL0052 LOW SOUND

YCAL0043-YCAL0052 ULTRA LOW SOUND (460V AND 380-415V 50 HZ)

035-21447-102 REV A

ELEMENTARY DIAGRAM

POWER CIRCUIT

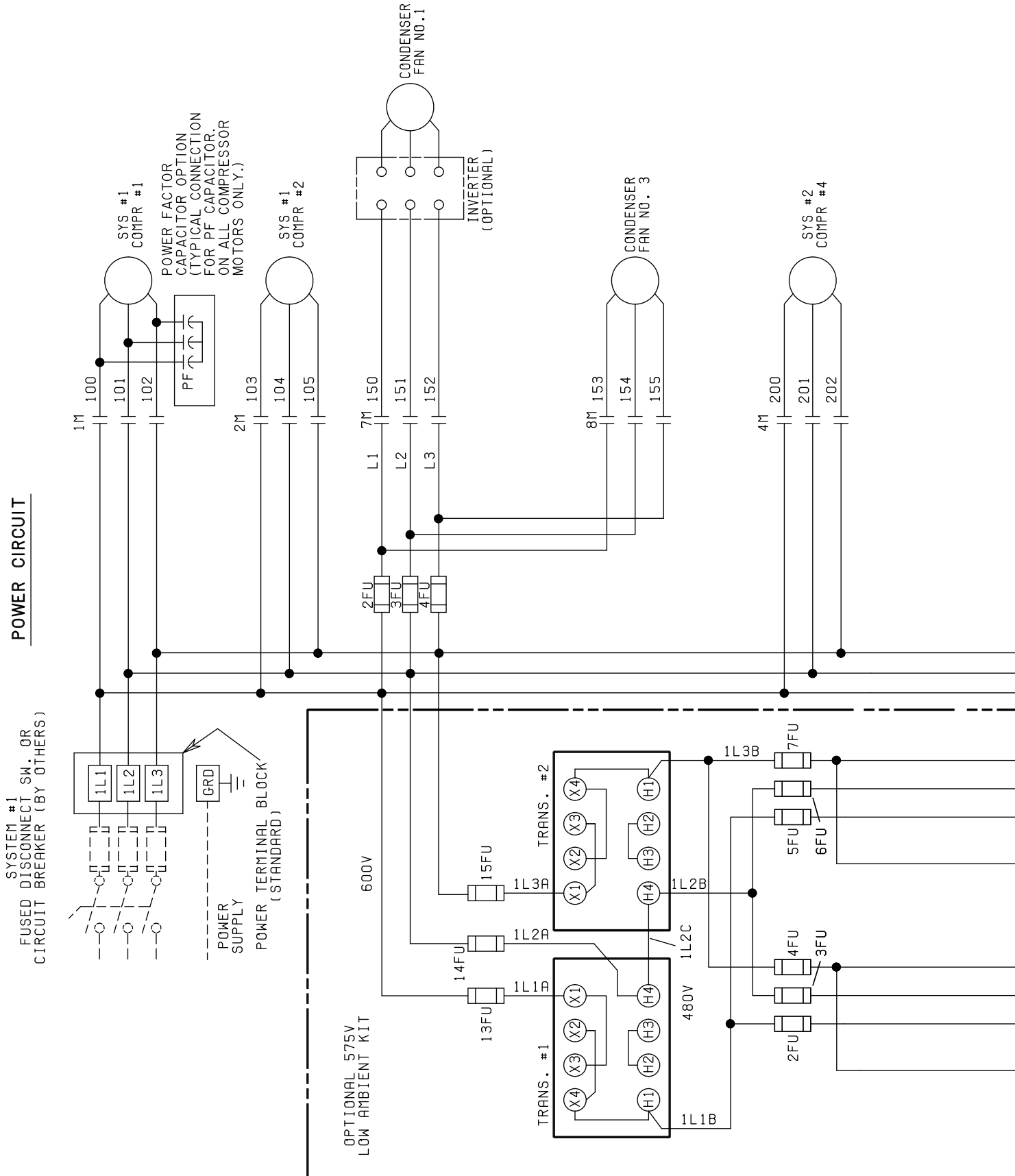
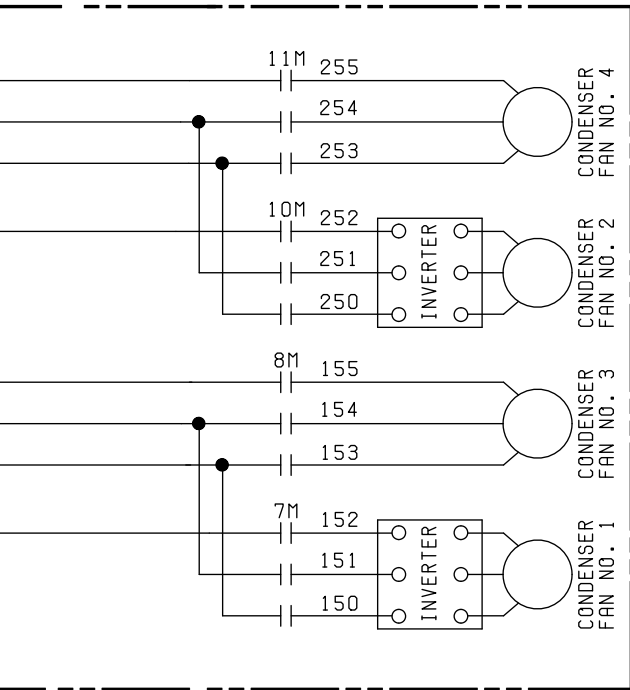
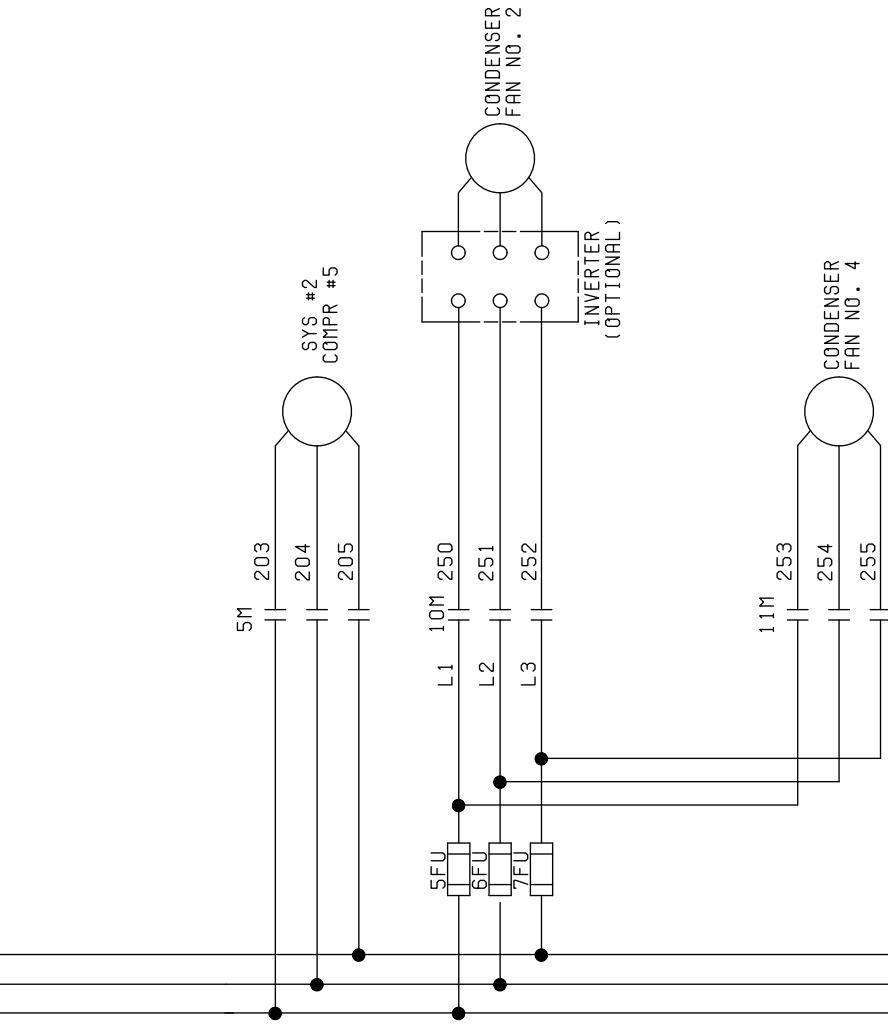
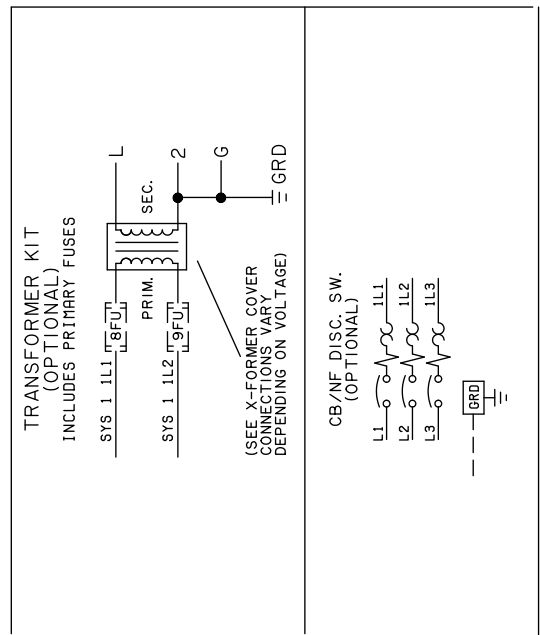
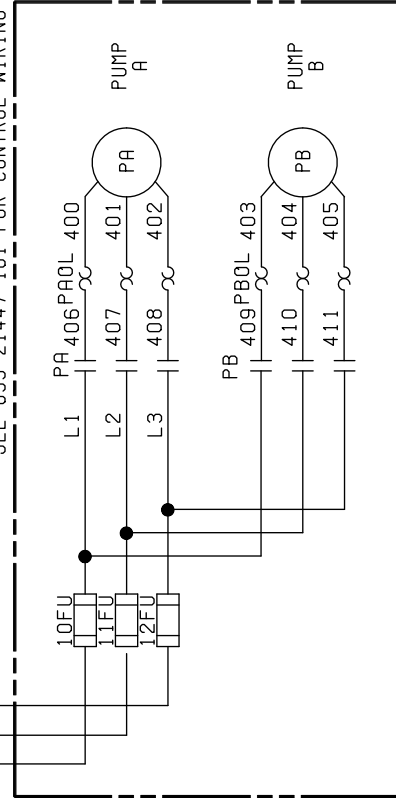

FIGURE 22 - POWER WIRING, DUAL CIRCUIT



OPTIONAL PUMP PACKAGE
(DUAL & SINGLE PUMP SHOWN)
SEE 035-21447-101 FOR CONTROL WIRING



YCAL0043-YCAL0052 LOW SOUND

YCAL0043-YCAL0052 ULTRA LOW SOUND (460V AND 380-415V 50 HZ)

035-21447-404 REV -

CONNECTION

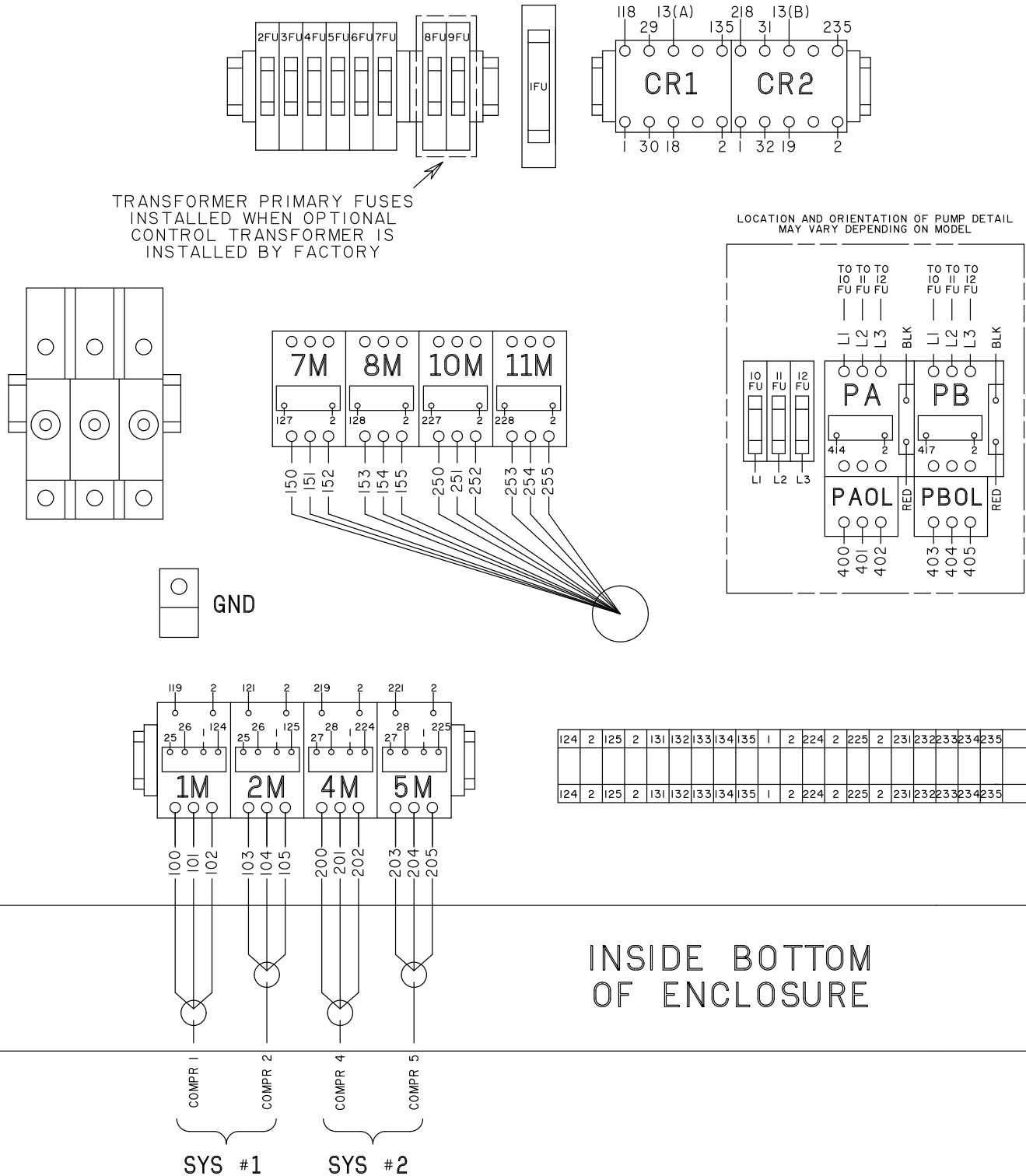
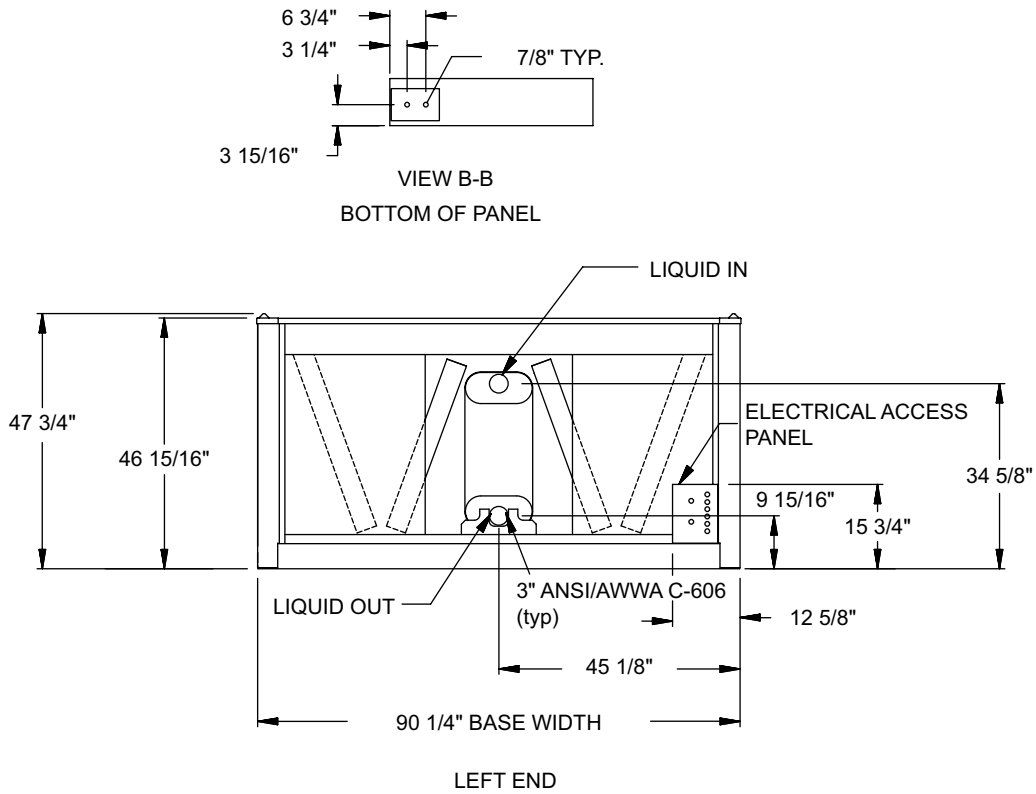

FIGURE 28 - CONNECTION WIRING, DUAL CIRCUIT

DIMENSIONS – YCAL0046 (ENGLISH)



NOTE:

Placement on a level surface of free of obstructions (including snow, for winter operation) or air circulation ensures rated performance, reliable operation, and ease of maintenance. Site restrictions may compromise minimum clearances indicated below, resulting in unpredictable airflow patterns and possible diminished performance. YORK's unit controls will optimize operation without nuisance high-pressure safety cutouts; however, the system designer must consider potential performance degradation. Recommended minimum clearances: front to wall – 6"; rear to wall – 6"; cooler end to wall – 4'0"; coil end to wall – 6"; top – no obstructions allowed; distance between adjacent units – 10'. No more than one adjacent wall may be higher than the unit. 1" nominal deflection isolators (not shown) will increase overall unit height by 6".

DIMENSIONS – YCAL0046 (ENGLISH) (CONT'D)

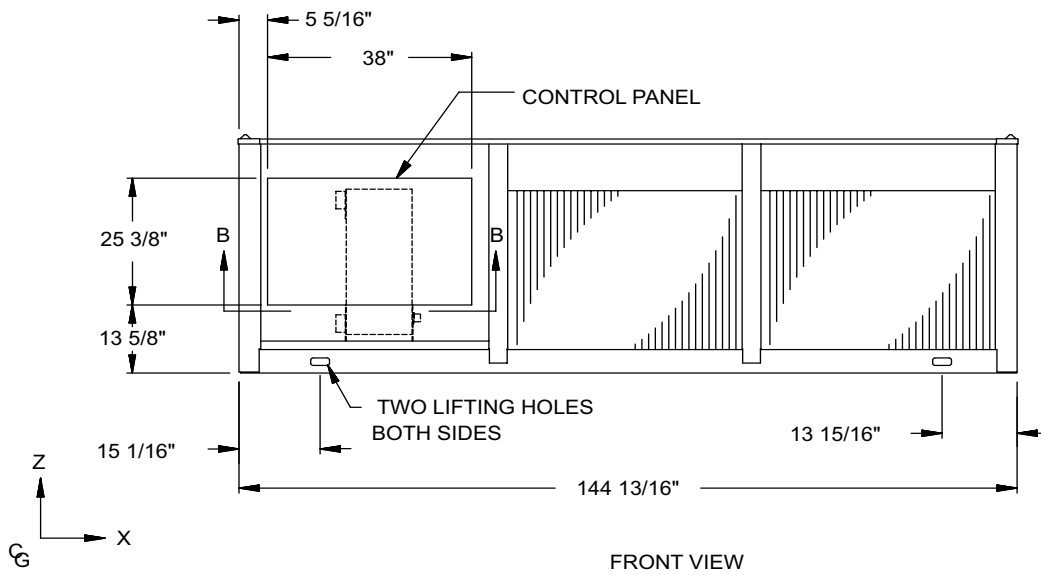
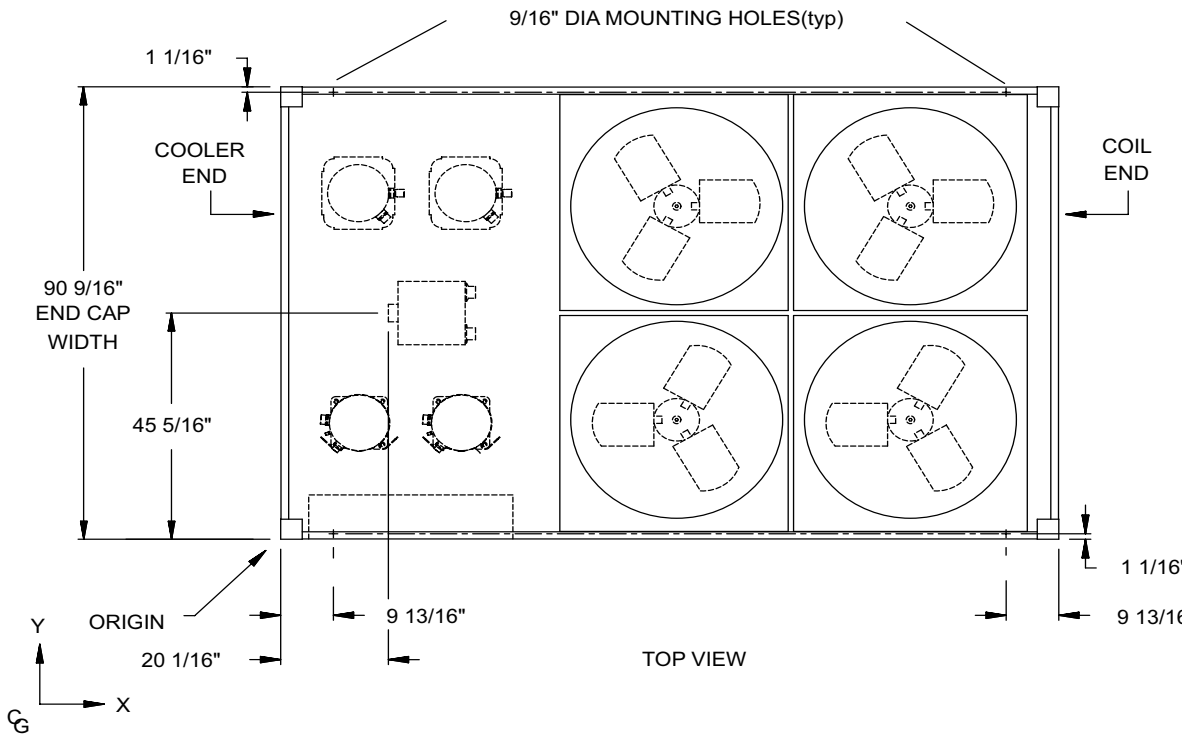

TECHNICAL DATA – CLEARANCES

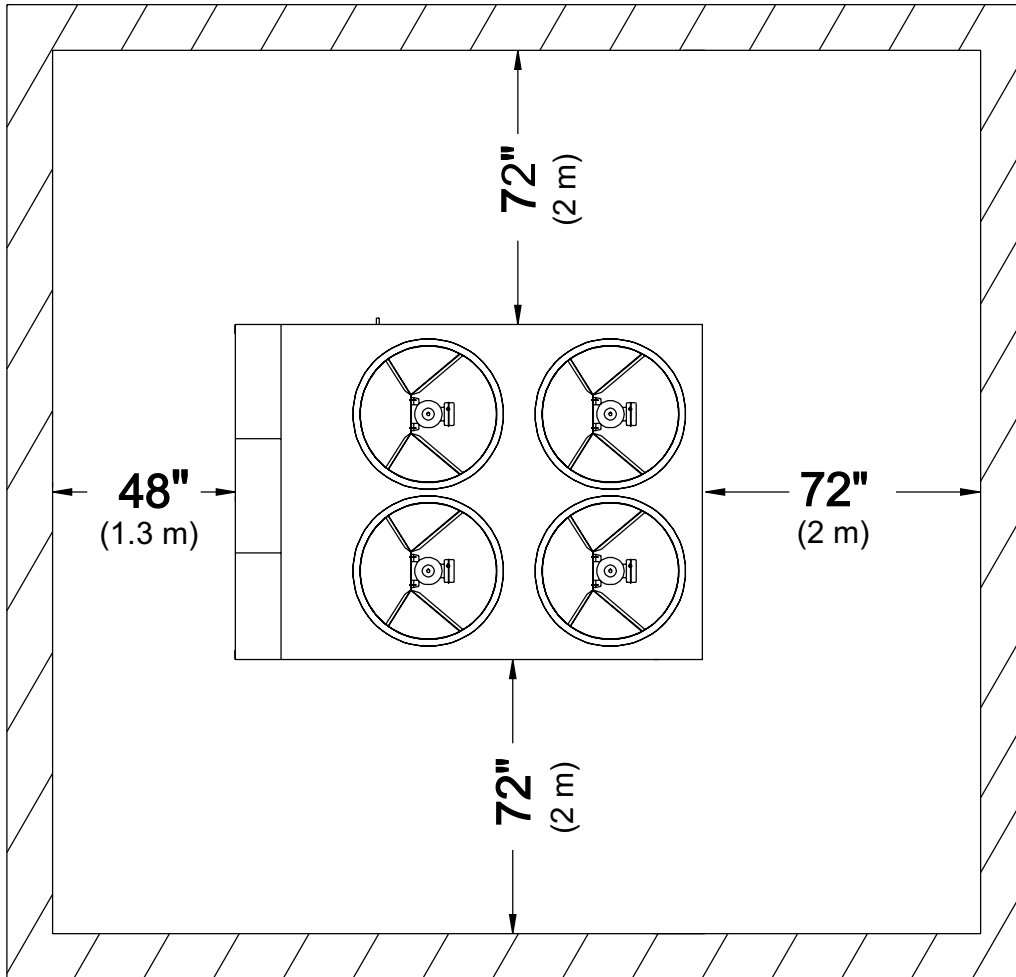

LD10506

NOTES:

1. No obstructions allowed above the unit.
2. Only one adjacent wall may be higher than the unit.
3. Adjacent units should be 10 feet (3 Meters) apart.

FIGURE 30 - UNIT CLEARANCES – ALL MODELS

WEIGHT DISTRIBUTION AND ISOLATOR MOUNTING POSITIONS

YCAL0043 – 0066

General

Weights of specific chiller models vary significantly as options are added. As a result, total weights, weights at individual isolator positions, and actual isolator selection at each position cannot be published due to the vast number of possible combinations. This information will be available when the specific chiller/ option selection is made from the local YORK sales office. Be aware, weights will change with each option along with possible isolator changes. Weights and isolators may need to be recalculated when the option selections are changed.

Whenever the isolator option is ordered, the isolators will be shipped loose with the chiller. Packed with the isolators and also in the control panel information packet is a drawing and table specifically for each chiller, based on the option selection. The drawing and table will be similar to the ones shown below. The drawing will show the isolator locations along with the weight in pounds and kilograms at the specific location, isolator position, and location measurements for each isolator.

Approximate Isolator Locations

Order No: 051138540701
 Line No: 1

UNIT SHIPPING WEIGHT (DISPLAY ON UNIT DATA NAMEPLATE)	KG	LBS.
	1360	2999

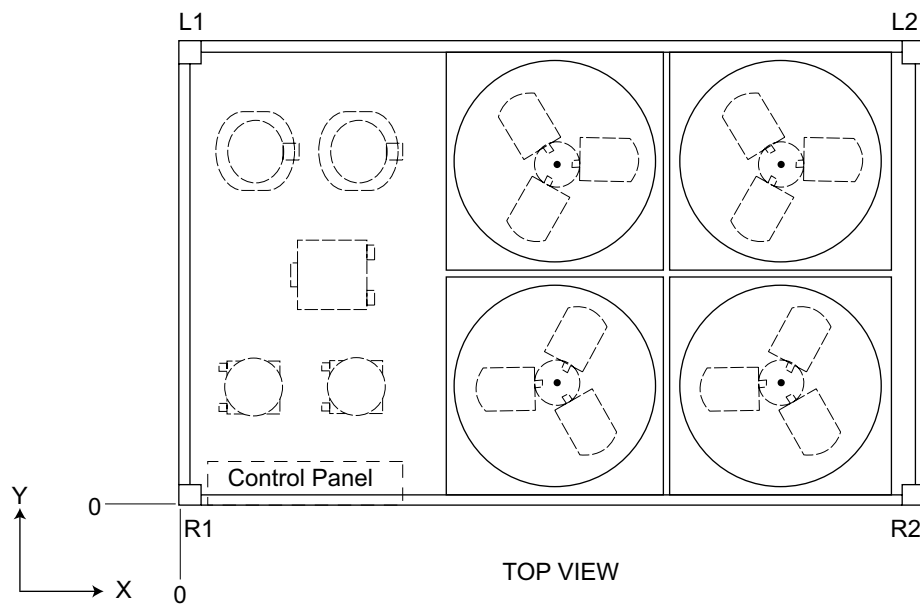

LD21562

LOCATION	X DISTANCE INCHES (MM)	Y DISTANCE INCHES (MM)	JCI PART NUMBER	SAP NUMBER	COLOUR	OPERATING WEIGHT
R1	9.8 (249)	1.1 (28)	029-25335-002	434004	RD-4 Brick Red-WR	941
R2	135 (3429)	1.1 (28)	029-25335-001	434002	RD-3 Charcoal-WR	613
L1	9.8 (249)	89.5 (2273)	029-25335-002	434004	RD-4 Brick Red-WR	875
L2	135 (3429)	89.5 (2273)	029-25335-001	434002	RD-3 Charcoal-WR	570

SAMPLE PRINTOUT SUPPLIED IN THE ISOLATOR PACKAGE AND IN THE CHILLER PANEL LITERATURE PACKET.

DURULENE ISOLATOR CROSS-REFERENCE

RD-Style Isolators

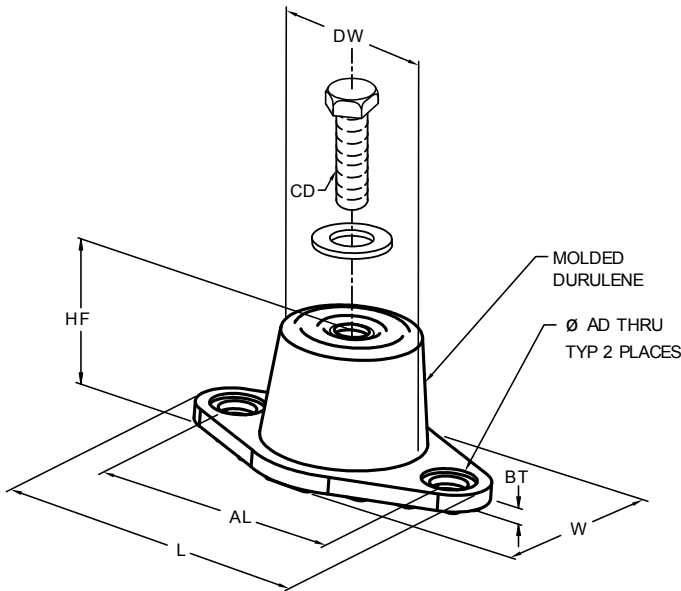

Notes:

1. All dimensions are inches, interpreted per ANSI Y14.
2. Refer to next page for installation instructions.
3. Mount molded in weather resistant durulene compound as standard. Also available in other materials such as natural rubber, extreme high temperature silicone, high-damped silicone, nitrile and EDPM.
4. AL = Mounting hole center to center spacing.
5. HF = Free height of mount, prior to loading. Operating height calculated by the free height less the static deflection under load. All dimensions for reference only.
6. Hardware is zinc-electroplated.

MOUNT TYPE	DIMENSION DATA (INCHES)							
	L	W	HF	AL	AD	BT	CD	DW
RD1-WR	3.13	1.75	1.25	2.38	0.34	0.19	5/16-18 UNC X 3/4	1.25
RD2-WR	3.88	2.38	1.75	3.00	0.34	0.22	3/8-16 UNC X 1	1.75
RD3-WR	5.50	3.38	2.88	4.13	0.56	0.25	1/2-13 UNC X 1	2.50
RD4-WR	6.25	4.63	2.75	5.00	0.56	0.38	1/2-13 UNC X 1	3.00

MODEL NUMBER	RATED CAPACITY [LBS]	RATED DEFLECTION [IN]	DURO (± 5)
RD2-LIGHT BLUE-WR	35	0.4	30
RD2-BROWN-WR	45	0.4	40
RD2-BRICK RED-WR	70	0.4	50
RD 2-LIME-WR	120	0.4	60

MODEL NUMBER	RATED CAPACITY [LBS]	RATED DEFLECTION [IN]	DURO (± 5)
RD3-BROWN-WR	250	0.5	40
RD3-BRICK RED-WR	525	0.5	50
RD3-LIME-WR	750	0.5	60
RD3-CHARCOAL-WR	1100	0.5	70

MODEL NUMBER	RATED CAPACITY [LBS]	RATED DEFLECTION [IN]	DURO (± 5)
RD2-LIGHT BLUE-WR	135	0.5	30
RD2-BROWN-WR	170	0.5	40
RD2-BRICK RED-WR	240	0.5	50
RD 2-LIME-WR	380	0.5	60
RD2 CHARCOAL-WR	550	0.5	70

MODEL NUMBER	RATED CAPACITY [LBS]	RATED DEFLECTION [IN]	DURO (5)
RD4-BROWN-WR	1500	0.5	40
RD4-BRICK RED-WR	2250	0.5	50
RD4-LIME-WR	3000	0.5	60
RD4-CHARCOAL-WR	4000	0.5	70

FIGURE 33 - DURULENE ISOLATOR CROSS-REFERENCE

INSTALLATION OF DURULENE VIBRATION ISOLATORS

Units shipped on or after June 15, 2008

1. Read instructions in their entirety before beginning installation.
2. Isolators are shipped fully assembled and are to be positioned in accordance with the submittal drawings or as otherwise recommended.
3. Set isolators on floor, housekeeping pad, or sub-base, ensuring that all isolator centerlines match the equipment mounting holes. The VMC group recommends that the isolator base ("A") be installed on a level surface. Shim or grout as required, leveling all isolator bases to the same elevation (1/32-inch maximum difference can be tolerated).
4. Bolt or anchor all isolators to supporting structure utilizing base thru holes ("B").
5. Remove top bolt and top washer. Place equipment on top of isolators so that mounting holes in equipment or base line up with threaded hole ("C").
6. Reinstall top bolt and washer and tighten down.
7. Installation is complete.

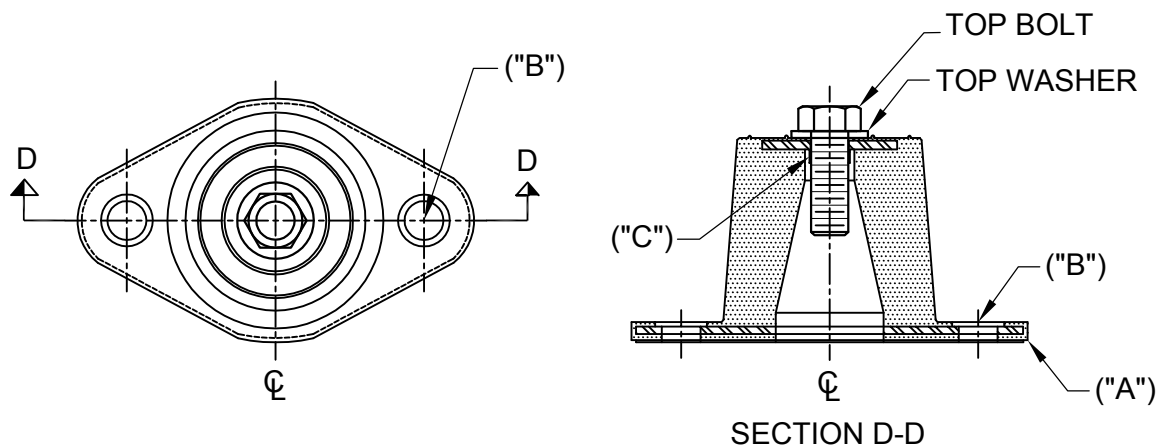

LD13762B

FIGURE 34 - INSTALLATION OF DURULENE VIBRATION ISOLATORS

SECTION 6 – COMMISSIONING

COMMISSIONING



Commissioning of this unit should only be carried out by YORK Authorized personnel.

Commissioning personnel should be thoroughly familiar with the information contained in this literature, in addition to this section.

Perform the commissioning using the detailed checks outlined in the Equipment Start-Up Check List (Page 149) as the commissioning procedure is carried out.

PREPARATION – POWER OFF

The following basic checks should be made with the customer power to the unit switched OFF.

Inspection

Inspect unit for installation damage. If found, take action and/or repair as appropriate.

Refrigerant Charge

Packaged units are normally shipped as standard with a full refrigerant operating charge. Check that refrigerant pressure is present in both systems and that no leaks are apparent. If no pressure is present, a leak test must be undertaken, the leak(s) located and repaired. Remote systems and units are supplied with a nitrogen holding charge. These systems must be evacuated with a suitable vacuum pump/recovery unit as appropriate to below 500 microns.

Do not liquid charge with static water in the cooler. Care must also be taken to liquid charge slowly to avoid excessive thermal stress at the charging point. Once the vacuum is broken, charge into the condenser coils with the full operating charge as given in the Technical Data Section.

Service and Oil Line Valves

Open each compressor suction, economizer, and discharge service valve. If valves are of the back-seat type, open them fully (counterclockwise) then close one turn of the stem to ensure operating pressure is fed to pressure transducers. Open the liquid line service valve and oil return line ball valve fully in each system.

Compressor Oil

To add oil to a circuit – connect a YORK hand oil pump (Part No. 470-10654-000) to the 1/4" oil charging connection on the compressors with a length of clean hose or copper line, but do not tighten the flare nut. Using clean oil of the correct type (“T” oil), pump oil until all air has been purged from the hose then tighten the nut. Stroke the oil pump to add oil to the oil system. Approximately 1.8 to 2.3 gallons is present in the each refrigerant system. Oil levels in the oil equalizing line sight glass should be between the bottom and the middle of the sight glass with the system off. High oil levels may cause excessive oil carryover in the system. High oil concentration in the system may cause nuisance trips resulting from incorrect readings on the level sensor and temperature sensors. Temperature sensor errors may result in poor liquid control and resultant liquid overfeed and subsequent damage to the compressor. While running, a visible sign of oil splashing in the sight glass is normal.

Fans

Check that all fans are free to rotate and are not damaged. Ensure blades are at the same height when rotated. Ensure fan guards are securely fixed.

Isolation / Protection

Verify all sources of electrical supply to the unit are taken from a Single-Point of isolation. Check that the maximum recommended fuse sizes given in the Technical Data Section has not been exceeded.

Control Panel

Check the panel to see that it is free of foreign materials (wire, metal chips, etc.) and clean out if required.

Power Connections

Check that the customer power cables are connected correctly to the terminal blocks or optional circuit breaker. Ensure that connections of power cables within the panels to the circuit breaker or terminal blocks are tight.

Grounding

Verify that the unit’s protective ground terminal(s) are properly connected to a suitable grounding point. Ensure that all unit internal ground connections are tight.

Supply Voltage

Verify that the site voltage supply corresponds to the unit requirement and is within the limits given in the Technical Data Section.

PREPARATION – POWER ON



Perform the commissioning using the detailed checks outlined in the Equipment Start-Up Check List as the commissioning procedure is carried out.

Apply power to the chiller. Turn on the option panel circuit breaker if supplied.



The machine is now live!

Switch Settings

Assure the chiller OFF/ON Unit Switch at the bottom of the keypad is OFF. Place the optional circuit breaker handle on the panel door to ON. The customer's disconnection devices can now be set to ON.

Verify the control panel display is illuminated. Assure the system switches under the SYSTEM SWITCHES key are in the OFF position.

Compressor Heaters

Verify the compressor heaters are energized. If the ambient temperature is above 96 °F (36 °C) the compressor heaters must be ON for at least 8 hours before start-up to ensure all refrigerant liquid is driven out of the compressor and the oil. If the ambient temperature is below 86 °F (30 °C), allow 24 hours.

Water System

Verify the chilled liquid system has been installed correctly, and has been commissioned with the correct direction of water flow through the cooler. The inlet should be at the refrigerant piping connection end of the cooler. Purge air from the top of the cooler using the plugged air vent mounted on the top of the cooler body.

Flow rates and pressure drops must be within the limits given in the Technical Data Section. Operation outside of these limits is undesirable and could cause damage.

If mains power must be switched OFF for extended maintenance or an extended shutdown period, the compressor suction, discharge and economizer service stop valves should be closed (clockwise). If there is a possibility of liquid freezing due to low ambient temperatures, the coolers should be drained or power should be applied to the chiller. This will allow the cooler heater to protect the cooler from freezing down to -20 °F. Before placing the unit back in service, valves should be opened and power must be switched on (if power is removed for more than 8 hours) for at least 8 hours (24 hours if ambient temperature is below 86 °F [30 °C]) before the unit is restarted.

Flow Switch

Verify a chilled water flow switch is correctly fitted in the customer's piping on the cooler outlet, and wired into the control panel correctly using shielded cable.

There should be a straight run of at least 5 pipe diameters on either side of the flow switch. The flow switch should be connected to terminals 13 and 14 in the panel.

Temperature Sensor(s)

Ensure the leaving liquid temperature sensor is coated with heat conductive compound (Part No. 013-00890-000) and is inserted to the bottom of the water outlet sensor well in the cooler. This sensor also provides some freeze protection and must always be fully inserted in the water outlet sensor well.

**C. PANEL CHECKS
 (POWER ON - BOTH UNIT SWITCH OFF)**

1. Apply 3-phase power and verify its value. Voltage imbalance should be no more than 2% of the average voltage.
2. Apply 120VAC and verify its value on the terminal block in the Power Panel. Make the measurement between terminals 5 and 2 of CTB2. The voltage should be 120VAC +/- 10%
3. Program/verify the Cooling Setpoints, Program Setpoints, and Unit Options. Record the values below.

OPTIONS	
Display Language	ENGLISH
Sys 1 Switch	ON
Sys 2 Switch	ON
Chilled Liquid	GLYCOL
* Ambient Control	LOW AMBIENT
Local/Remote Mode	LOCAL
Control Mode	LEAVING LIQUID
Display Mode	IMPERIAL
* Lead/Lag Control	SYS #1 MAN. LEAD
* Fan Control	DISCHARGE PRESS.
Manual Override	OFF
Current Feedback	NONE
** Soft Start	NONE
** Unit Type	LIQUID CHILLER
** Refrigerant Type	R-410A
** Expansion Valve Type	THERMOSTATIC
COOLING SETPOINTS	
Cooling Setpoint	45F
Range	2.5F
EMS-PWM Max. Setpoint	55F
PROGRAM	
Discharge Pressure Cutout	575 PSIG
Suct. Pressure Cutout	70 PSIG
Low Amb. Temp. Cutout	20F
Leaving Liquid Temp. Cutout	36F
Anti-Recycle Time	600 SEC
Fan Control On Pressure	425 PSIG
Fan Differential Off Pressure	125 PSID
Total # of Compressors	4
* Number of Fans/System	2
* Unit/Sys Voltage	2.5 VOLTS
Unit ID	0

* Not on all models. ** Viewable only.

4. Put the unit into Service Mode and cycle each condenser fan to ensure proper rotation.
5. Prior to this main step, turn system 2 off. Connect a manifold gauge to system 1 suction and discharge service valves.
 Place the Unit Switch in the control panel to the "ON" position. As each compressor cycles on, ensure that the discharge pressure rises and the suction pressure decreases. If this does not occur, the compressor being tested is operating in the reverse direction and must be corrected. After verifying proper compressor rotation, turn the Unit Switch to "OFF"



The chilled liquid setpoint may need to be temporarily lowered to ensure all compressors cycle "ON".

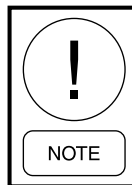

This unit uses scroll compressors which can only operate in one direction. Failure to observe this will lead to compressor failure.

6. YCAL0043 – YCAL0066 units only – Turn system 1 "OFF" and system 2 "ON"
 Place the Unit Switch in the control panel to the "ON" position. As each compressor cycles "ON", ensure that the discharge pressure rises and the suction pressure decreases. If this does not occur, the compressor being tested is operating in the reverse direction and must be corrected. After verifying proper compressor rotation, turn the Unit Switch to "OFF"

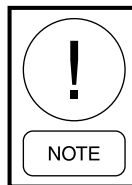

This unit uses scroll compressors which can only operate in one direction. Failure to observe this will lead to compressor failure.

D. CHECKING SUPERHEAT AND SUBCOOLING

The subcooling temperature of each system can be calculated by recording the temperature of the liquid line at the outlet of the condenser and subtracting it from the liquid line saturation temperature at the liquid stop valve (liquid line saturation temp. is converted from a temperature/pressure chart).

Example:

$$\begin{aligned} &\text{Liquid line pressure} = \\ &325 \text{ PSIG converted to temp. } 101 \text{ }^\circ\text{F} \\ &\text{Minus liquid line temp. } -86 \text{ }^\circ\text{F} \\ &\text{Subcooling} = 15 \text{ }^\circ\text{F} \end{aligned}$$

The subcooling should be adjusted to 15 °F at design conditions.

1. Record the liquid line pressure and its corresponding temperature, liquid line temperature and subcooling below:

	SYS 1	SYS 2	
Liq Line Press =	<u>323</u>	<u>317</u>	PSIG
Saturated Temp =	<u>101.0</u>	<u>99.7</u>	°F
Liq Line Temp =	<u>80.0</u>	<u>79.0</u>	°F @
Subcooling =	<u>21.0</u>	<u>20.7</u>	43°F OAT

After the subcooling is verified, the suction superheat should be checked. The superheat should be checked only after steady state operation of the chiller has been established, the leaving water temperature, and the unit is running in a fully loaded condition. Correct superheat setting for a system is 10°F - 15°F (5.56°C - 8.33 °C) 18" (46 cm) from the heat exchanger.

Superheat should typically be set for not less than 10°F with only a single compressor running on a circuit. The superheat is calculated as the difference between the actual temperature of the returned refrigerant gas in the suction line entering the compressor and the temperature corresponding to the suction pressure as shown in a standard pressure/temperature chart.

Example:

$$\begin{aligned} &\text{Suction Temp} = 46 \text{ }^\circ\text{F} \\ &\text{minus Suction Press} \\ &105 \text{ PSIG converted to Temp } -34 \text{ }^\circ\text{F} \\ &\text{Superheat} = 12 \text{ }^\circ\text{F} \end{aligned}$$

When adjusting the expansion valve (TXV only), the adjusting screw should be turned not more than one turn at a time, allowing sufficient time (approximately 15 minutes) between adjustments for the system and the thermal expansion valve to respond and stabilize.

Assure that superheat is set at a minimum of 10°F (5.56 °C) with a single compressor running on each circuit.

2. Record the suction temperature, suction pressure, suction saturation temperature, and superheat of each system below:

	SYS 1	SYS 2	
Suction Temp =	<u>45.0</u>	<u>41.0</u>	°F
Suction Pressure =	<u>104</u>	<u>99</u>	PSIG
Saturation Temp =	<u>33.4</u>	<u>31.0</u>	°F
Superheat =	<u>11.6</u>	<u>10.0</u>	°F

E. LEAK CHECKING

Leak check compressors, fittings, and piping to ensure no leaks.

If the unit is functioning satisfactorily during the initial operating period, no safeties trip and the compressors cycle to control water temperature to setpoint, the chiller is ready to be placed into operation.



UNIT OPERATING SEQUENCE

The operating sequence described below relates to operation on a hot water start after power has been applied, such as start-up commissioning. When a compressor starts, internal timers limit the minimum time before another compressor can start to 1 minute.

1. For the chiller system to run, the Flow Switch must be closed, any remote cycling contacts must be closed, the Daily Schedule must not be scheduling the chiller OFF, and temperature demand must be present.
2. When power is applied to the system, the microprocessor will start a 2 minute timer. This is the same timer that prevents an instantaneous start after a power failure.
3. At the end of the 2 minute timer, the microprocessor will check for cooling demand. If all conditions allow for start, a compressor on the lead system will start and the liquid line solenoid will open. Coincident with the start, the anti-coincident timer will be set and begin counting downward from “60” seconds to “0” seconds.
4. If the unit is programmed for Auto Lead/Lag, the system with the shortest average run-time of the compressors will be assigned as the “lead” system. A new lead/lag assignment is made whenever all systems shut down.
5. Several seconds after the compressor starts, that systems first condenser fan will be cycled ON (outdoor air temperature more than 25 °F (-4 °C) or discharge pressure). See the section on Operating Controls for details concerning condenser fan cycling.
6. After 1 minute of compressor run time, the next compressor in sequence will start when a system has to load. Additional compressors will be started at 60 second intervals as needed to satisfy temperature setpoint.
7. If demand requires, the lag system will cycle on with the same timing sequences as the lead system after the lead system has run for five minutes. Refer to the section on Capacity Control for a detailed explanation of system and compressor staging.
8. As the load decreases below setpoint, the compressors will be shut down in sequence. This will occur at intervals of either 60, 30, or 20 seconds based on water temperature as compared to setpoint, and control mode. See the section on Capacity Control for a detailed explanation.
9. When the last compressor in a “system” (two or three compressors per system), is to be cycled OFF, the system will initiate a pump-down. Each “system” has a pump-down feature upon shut-off. On a non-safety, non-unit switch shutdown, the LLSV will be turned OFF and the last compressor will be allowed to run until the suction pressure falls below the suction pressure cutout or for 180 seconds, whichever comes first.

SECTION 7 – UNIT CONTROLS

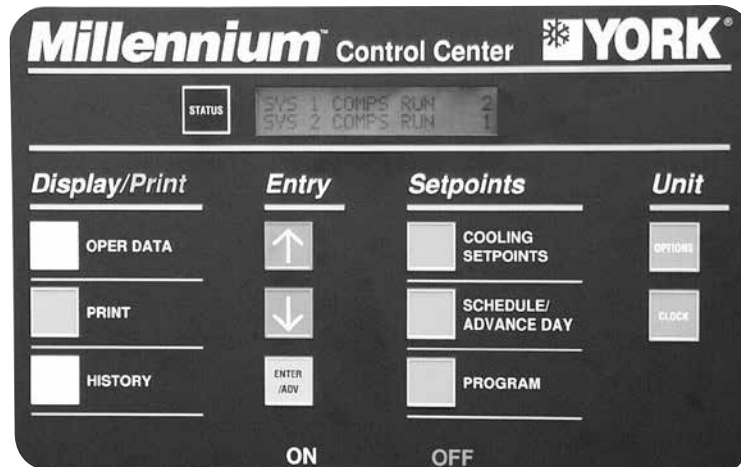

00065VIP

INTRODUCTION

The YORK Millennium MicroComputer Control Center is a microprocessor based control system designed to provide the entire control for the liquid chiller. The control logic embedded in the microprocessor based control system will provide control for the chilled liquid temperatures, as well as sequencing, system safeties, displaying status, and daily schedules. The MicroComputer Control Center consists of four basic components:

- IPU II and I/O Boards
- Transformer
- Display
- Keypad

The keypad allows programming and accessing setpoints, pressures, temperatures, cutouts, daily schedule, options, and fault information.

Remote cycling, demand limiting and chilled liquid temperature reset can be accomplished by field supplied contacts.

Compressor starting/stopping and loading/unloading decisions are performed by the Microprocessor to maintain leaving or return chilled liquid temperature. These decisions are a function of temperature deviation from setpoint.

A Master ON/OFF switch is available to activate or deactivate the unit.

IPU II AND I/O BOARDS

The IPU and I/O boards are assembled to function as a single microprocessor controller requiring no additional hardware. The IPU II board contains a coldfire microprocessor and is the controller and decision maker in the control panel. The I/O board handles all of the chiller I/O (Inputs and Outputs). System inputs from pressure transducers and temperature sensors are connected to the I/O board. The I/O board contains a processor capable of reading the inputs and controlling the outputs. It communicates through the transition header with the IPU II microprocessor.

The I/O board circuitry multiplexes the analog inputs, digitizes them, and constantly scans them to keep watch on the chiller operating conditions. The input values are transmitted serially to the IPU II microprocessor board. From this information, the IPU II then issues commands to the I/O board relay outputs to control contactors, solenoids, etc. for Chilled Liquid Temperature Control and to react to safety conditions. The I/O board converts logic signals to operate relay outputs to 115VAC levels used by motor contactors, fan contactors, solenoid valves, etc. to control system operation. The low voltage side of all relay coils on the I/O board are powered by +12V.

Keypad commands are actuated upon by the microprocessor to change setpoints, cutouts, scheduling, operating requirements, and to provide displays. The keypad and display are connected to the I/O board.

The on-board power supply converts 24VAC from 75VA, 120/24VAC 50/60Hz UL listed class 2 power transformer to +12V, +5V and +3.3V using switching

and linear voltage regulators located on the I/O and IPU II boards. These voltages are used to operate integrated circuitry on the board. The 40 character display and unit sensors (transducer and temperature sensors) are supplied power for the micro board +5V supply. 24VAC is rectified, but not regulated, to provide unregulated +30 VDC to supply all of the digital inputs.

The IPU II board contains one green “Power” LED to indicate that the board is powered up and one red “Status” LED to indicate by blinking that the processor is operating.

The I/O board contains one green “Power” LED to indicate that the board is powered up and one red “Status” LED to indicate by blinking that the processor is operating. The I/O board also contains two sets of Receiver/Transmit LED’s, one for each available serial communication port. The receive LED’s are green, and the Transmit LED’s are red.

A jumper on the I/O board selects 4 to 20mA or 0 to 10 VDC as the input type on the remote temperature reset analog input.

Unit Switch

A unit ON/OFF switch is just underneath the keypad. This switch allows the operator to turn the entire unit OFF if desired. The switch must be placed in the ON position for the chiller to operate.

Display

The 40 Character Display (2 lines of 20 characters) is a liquid crystal display used for displaying system parameters and operator messages.

The display in conjunction with the keypad, allows the operator to display system operating parameters as well as access programmed information already in memory. The display has a lighted background for night viewing and for viewing in direct sunlight.

When a key is pressed, such as the OPER DATA key, system parameters will be displayed and will remain on the display until another key is pressed. The system parameters can be scrolled with the use of the ↑ (up) and ↓ (down) arrow keys. The display will update all information at a rate of about 1 a second.

Display Messages may show characters indicating “greater than” (>) or “less than” (<). These characters indicate the actual values are greater than or less than the limit values which are being displayed.

Keypad

The 12 button non-tactile keypad allows the user to retrieve vital system parameters such as system pressures, temperatures, compressor running times and starts, option information on the chiller, and system setpoints. This data is useful for monitoring chiller operation, diagnosing potential problems, troubleshooting, and commissioning the chiller.

It is essential the user become familiar with the use of the keypad and display. This will allow the user to make full use of the capabilities and diagnostic features available.

Battery Back-up

The IPU II contains a Real Time Clock integrated circuit chip with an internal battery backup. The purpose of this battery backup is to assure any programmed values (setpoints, clock, cutouts, etc.) are not lost during a power failure regardless of the time involved in a power cut or shutdown period.

Transformer

A 75VA, 120/24VAC 50/60Hz transformer is provided to supply power to the Microprocessor Board, which in turn rectifies, filters, and regulates as necessary to supply power to the display, sensors, and transducers.

Single System Select and Programming # of Compressors

The control software is common between single (1) and dual (2) system units. A jumper is installed between terminals 13 and 17 on the user terminal block to configure a unit for a single system. Dual (2) system chillers do not have a jumper installed. The jumper is only checked by the microprocessor on power-up.

The total number of compressors is programmable under the PROGRAM key. Single (1) system chillers can have 2 or 3 compressors. Dual (2) system chillers can have 4, 5, or 6 compressors.

STATUS KEY



00066VIP

Unit Status

Pressing the STATUS key will enable the operator to determine current chiller operating status. The messages displayed will include running status, cooling demand, fault status and external cycling device status. The display will be a single message relating to the highest priority message as determined by the microprocessor. Status messages fall into the categories of General Status and Fault Status.

The following General, Safety, and Warning messages are displayed when the STATUS key is pressed. Following each displayed message is an explanation pertaining to that particular message.

General Status Messages

In the case of messages which apply to individual systems, SYS 1 and SYS 2 messages will both be displayed and may be different. In the case of single system units, all SYS 2 messages will be blank.

**UNIT SWITCH OFF
SHUTDOWN**

This message informs the operator that the On the control panel is in the OFF position which will not allow the unit to run.

**REMOTE CONTROLLED
SHUTDOWN**

The REMOTE CONTROLLED SHUTDOWN message indicates that either an ISN system or RCC has turned the unit OFF, not allowing it to run.

**DAILY SCHEDULE
SHUTDOWN**

The DAILY SCHEDULE SHUTDOWN message indicates that the daily/holiday schedule programmed is keeping the unit from running.

**REMOTE STOP
NO RUN PERM**

REMOTE STOP NO RUN PERM shows that either the flow switch is open or a remote start/stop contact is open in series with the flow switch. These contacts are connected to J13-5. A 3-second delay is built into the software to prevent nuisance shutdowns due to erroneous signals on the run permissive input.

**SYS 1 SYS SWITCH OFF
SYS 2 SYS SWITCH OFF**

SYS SWITCH OFF tells that the system switch under OPTIONS is turned OFF. The system will not be allowed to run until the switch is turned back ON.

**SYS 1 NO COOL LOAD
SYS 2 NO COOL LOAD**

This message informs the operator that the chilled liquid temperature is below the point (determined by the setpoint and control range) that the microprocessor will bring on a system or that the microprocessor has not loaded the lead system far enough into the loading sequence to be ready to bring the lag system ON. The lag system will display this message until the loading sequence is ready for the lag system to start.

**SYS 1 COMPS RUN X
SYS 2 COMPS RUN X**

The COMPS RUNNING message indicates that the respective system is running due to demand. The "X" will be replaced with the number of compressors in that system that are running.

7

```
SYS 1 AR TIMER XX S
SYS 2 AR TIMER XX S
```

The anti-recycle timer message shows the amount of time left on the respective systems anti-recycle timer. This message is displayed when the system is unable to start due the anti-recycle timer being active.

```
SYS 1 AC TIMER XX S
SYS 2 AC TIMER XX S
```

The anti-coincidence timer is a software feature that guards against 2 systems starting simultaneously. This assures instantaneous starting current does not become excessively high due to simultaneous starts. The microprocessor limits the time between compressor starts to 1 minute regardless of demand or the anti-recycle timer being timed out. The anti-coincidence timer is only present on two system units.

```
SYS 1 DSCH LIMITING
SYS 2 DSCH LIMITING
```

When this message appears, discharge pressure limiting is in effect. The Discharge Pressure Limiting feature is integral to the standard software control; however the discharge transducer is optional on some models. Therefore, it is important to keep in mind that this control will not function unless the discharge transducer is installed in the system.

The limiting pressure is a factory set limit to keep the system from faulting on the high discharge pressure cutout due to high load or pull down conditions. When the unload point is reached, the microprocessor will automatically unload the affected system by de-energizing one compressor. The discharge pressure unload will occur when the discharge pressure gets within 10 PSIG (0.69 barg) of the programmed discharge pressure cutout. This will only happen if the system is fully loaded and will shut only one compressor OFF. If the system is not fully loaded, discharge limiting will not go into effect. Reloading the affected system will occur when the discharge pressure drops to 85% of the unload pressure and 10 minutes have elapsed.

```
SYS 1 SUCT LIMITING
SYS 2 SUCT LIMITING
```

When this message appears, suction pressure limiting is in effect. The suction pressure limit is a control point that limits the loading of a system when the suction pressure drops to within 15% above the suction

pressure cutout. On a standard system programmed for 44 PSIG (3.0 Bar) suction pressure cutout, the microprocessor would inhibit loading of the affected system with the suction pressure less than or equal to 1.15 times 44 PSIG (3.0 Bar), which equals 50 PSIG (3.5 Bar). The system will be allowed to load after 60 seconds and after the suction pressure rises above the suction pressure load limit point.

```
SYS 1 LOAD LIMIT XX %
SYS 2 LOAD LIMIT XX %
```

This message indicates that load limiting is in effect and the percentage of the limiting in effect. This limiting could be due to the load limit/PWM input, ISN or RCC controller sending a load limit command.

```
MANUAL
OVERRIDE
```

If MANUAL OVERRIDE mode is selected, the STATUS display will display this message. This will indicate that the Daily Schedule is being ignored and the chiller will start-up when chilled liquid temperature allows, Remote Contacts, Unit Switch and System Switches permitting. This is a priority message and cannot be overridden by anti-recycle messages, fault messages, etc. when in the STATUS display mode. Therefore, do not expect to see any other STATUS messages when in the MANUAL OVERRIDE mode. MANUAL OVERRIDE is to only be used in emergencies or for servicing. Manual override mode automatically disables itself after 30 minutes.

```
SYS 1 PUMPING DOWN
SYS 2 PUMPING DOWN
```

The PUMPING DOWN message indicates that a compressor in the respective system is presently in the process of pumping the system down. When pumpdown is initiated on shutdown, the liquid line solenoid or EEV will close and a compressor will continue to run. When the suction pressure decreases to the suction pressure cutout setpoint or runs for 180 seconds, whichever comes first, the compressor will cycle OFF.

Fault Safety Status Messages

Safety Status messages appear when safety thresholds in the unit have been exceeded. Safeties are divided into two categories – System Safeties and Unit Safeties. System safeties are faults that cause the individual system to be shut down. Unit safeties are faults that cause all running compressors to be shut down. Following are display messages and explanations.

System Safeties

System safeties are faults that cause individual systems to be shut down if a safety threshold is exceeded for 3 seconds. They are auto reset faults in that the system will be allowed to restart automatically after the fault condition is no longer present. However, if 3 faults on the same system occur within 90 minutes, that system will be locked out on the last fault. This condition is then a manual reset. The system switch (under OPTIONS key) must be turned OFF and then back ON to clear the lockout fault. Fault messages will be displayed whenever a system is locked out.

```
SYS 1 HIGH DSCH PRES
SYS 2 HIGH DSCH PRES
```

The Discharge Pressure Cutout is a software cutout in the microprocessor and is backed-up by a mechanical high pressure cutout switch located in the refrigerant circuit. It assures that the system pressure does not exceed safe working limits. The system will shutdown when the programmable cutout is exceeded and will be allowed to restart when the discharge pressure falls 40 PSIG below the cutout. *Discharge transducers must be installed for this function to operate.*

```
SYS 1 LOW SUCT PRESS
SYS 2 LOW SUCT PRESS
```

The Suction Pressure Cutout is a software cutout that helps protect the chiller from an evaporator freeze-up should the system attempt to run with a low refrigerant charge or a restriction in the refrigerant circuit.

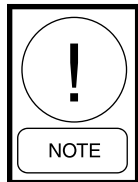

Repeated starts after resetting a low suction pressure fault will cause evaporator freeze-up. Whenever a system locks out on this safety or any safety, immediate steps should be taken to identify the cause.

At system start, the cutout is set to 10% of programmed value. During the next 3 minutes the cutout point is ramped up to the programmed cutout point. If at any time during this 3 minutes the suction pressure falls below the ramped cutout point, the system will stop. This cutout is completely ignored for the first 30 seconds of system run time to avoid nuisance shutdowns, especially on units that utilize a low pressure switch in place of the suction pressure transducer.

After the first 3 minutes, if the suction pressure falls below the programmed cutout setting, a “transient protection routine” is activated. This sets the cutout at 10% of the programmed value and ramps up the cutout over the next 30 seconds. If at any time during this 30 seconds the suction pressure falls below the ramped cutout, the system will stop.

```
SYS 1 MP / HPCO FAULT
SYS 2 MP / HPCO FAULT
```

```
SYS 1 MP / HPCO INHIB
SYS 2 MP / HPCO INHIB
```

The Motor Protector/Mechanical High Pressure Cutout protects the compressor motor from overheating or the system from experiencing dangerously high discharge pressure.

This fault condition is present when CR1 (SYS 1) or CR2 (SYS 2) relays de-energize due to the HP switch or motor protector opening. This causes the respective CR contacts to open causing 0VDC to be read on the inputs to the microboard. The fault condition is cleared when a 30VDC signal is restored to the input.

The internal motor protector opens at 185 °F to 248 °F (85 °C to 120 °C) and auto resets. The mechanical HP switch opens at 585 PSIG plus or minus 10 PSIG (27.92 barg plus or minus .69 barg) and closes at 330 PSIG plus or minus 25 PSIG (22.75 barg plus or minus 1.72 barg).

The compressor is also equipped with a discharge temperature sensor for the purpose of sensing internal scroll temperature. This sensor protects the scrolls from overheating due to inadequate cooling that may occur when refrigerant charge is low, or superheat is too high.

When the sensor senses a high temperature, it opens the motor protector circuit in the compressor causing the compressor to shut down.

During the first two faults an MP/HP INHIBIT message will be displayed and the system will not be locked out. Only after the third fault in 90 minutes will the MP/HPCO FAULT message be displayed.

Whenever the motor protector or discharge sensor shuts down a compressor and the system, the internal compressor contacts will open for a period of 30 minutes to assure that the motor or scroll temperatures

have time to dissipate the heat and cool down. The MP/HP INHIBIT message will be displayed while these contacts are open or when the HPCO is open. While this message is displayed, the compressors will not be permitted to start.

After 30 minutes, the contacts will close and the system will be permitted to restart. The microprocessor will not try to restart the compressors in a system that shuts down on this safety for a period of 30 minutes to allow the internal compressor to time out.

During the 30 minute timeout, the MP/HPCO INHIB message will be displayed. The MP/HPCO fault will only be displayed after 3 shutdowns in 90 minutes, indicating the system is locked out and will not restart.

```
SYS 1 HIGH MTR CURR
SYS 2 HIGH MTR CURR
```

When the System Current Feedback option is installed and selected (Option 11 under OPTIONS key Current Feedback), this safety will operate as follows. If the actual feedback voltage of the system proportional to currents exceeds the programmed trip voltage for 5 seconds, the system will shutdown.

This safety will shut down a system if either the suction temperature or suction pressure sensors read out of range high or low. This condition must be present for 3 seconds to cause a system shutdown. The safety locks out a system after the first fault and will not allow automatic restarting.

Unit Safeties

Unit safeties are faults that cause all running compressors to be shut down. Unit faults are auto reset faults in that the unit will be allowed to restart automatically after the fault condition is no longer present.

```
UNIT FAULT :
LOW AMBIENT TEMP
```

The Low Ambient Temperature Cutout is a safety shutdown designed to protect the chiller from operating in a low ambient condition. If the outdoor ambient temperature falls below the programmable cutout, the chiller will shut down. Restart can occur when temperature rises 2 °F above the cutoff.

```
UNIT FAULT :
LOW LIQUID TEMP
```

The Low Leaving Chilled Liquid Temperature Cutout protects the chiller from an evaporator freeze-up should the chilled liquid temperature drop below the freeze point. This situation could occur under low flow conditions or if the micro panel setpoint values are improperly programmed. Anytime the leaving chilled liquid temperature (water or glycol) drops below the cutout point, the chiller will shutdown. Restart can occur when chilled liquid temperature rises 2 °F above the cutout.

```
UNIT FAULT :
115VAC UNDER VOLTAGE
```

The Under Voltage Safety assures that the system is not operated at voltages where malfunction of the microprocessor could result in system damage. When the 115VAC to the micro panel drops below a certain level, a unit fault is initiated to safely shut down the unit. Restart is allowed after the unit is fully powered again and the anti-recycle timers have finished counting down.

```
UNIT FAULT :
HIGH MTR CURR
```

When the CURRENT FEEDBACK ONE PER UNIT option is selected under the OPTIONS key, the unit will shut down when the voltage exceeds the programmed trip voltage for 5 seconds.

The trip voltage is programmed at the factory according to compressor or unit RLA.

Restart will occur after the anti-recycle timer times out.

Unit Warning

The following messages are not unit safeties and will not be logged to the history buffer. They are unit warnings and will not auto-restart. Operator intervention is required to allow a restart of the chiller.

```
!! LOW BATTERY !!
CHECK PROG / SETP / OPTN
```

The Low Battery Warning can only occur at unit power-up. On micro panel power-up, the RTC battery is

checked. If a low battery is found, all programmed setpoints, program values, options, time, schedule, and history buffers will be lost. These values will all be reset to their default values which may not be the desired operating values. Once a faulty battery is detected, the unit will be prevented from running until the PROGRAM key is pressed. Once the PROGRAM key is pressed the anti-recycle timers will be set to the programmed anti-recycle time to allow the operator time to check setpoints, and if necessary, reprogram programmable values and options.

If a low battery is detected, it should be replaced as soon as possible. The programmed values will all be lost and the unit will be prevented from running on the next power interruption. The RTC/battery (031-00955-000) is located at U17 on the microboard.

**I N C O R R E C T
U N I T T Y P E**

This indicates the condensing unit jumper is installed on J11-12. This jumper must be removed to operate the chiller.

Status Key Messages

TABLE 11 - STATUS KEY MESSAGES QUICK REFERENCE LIST

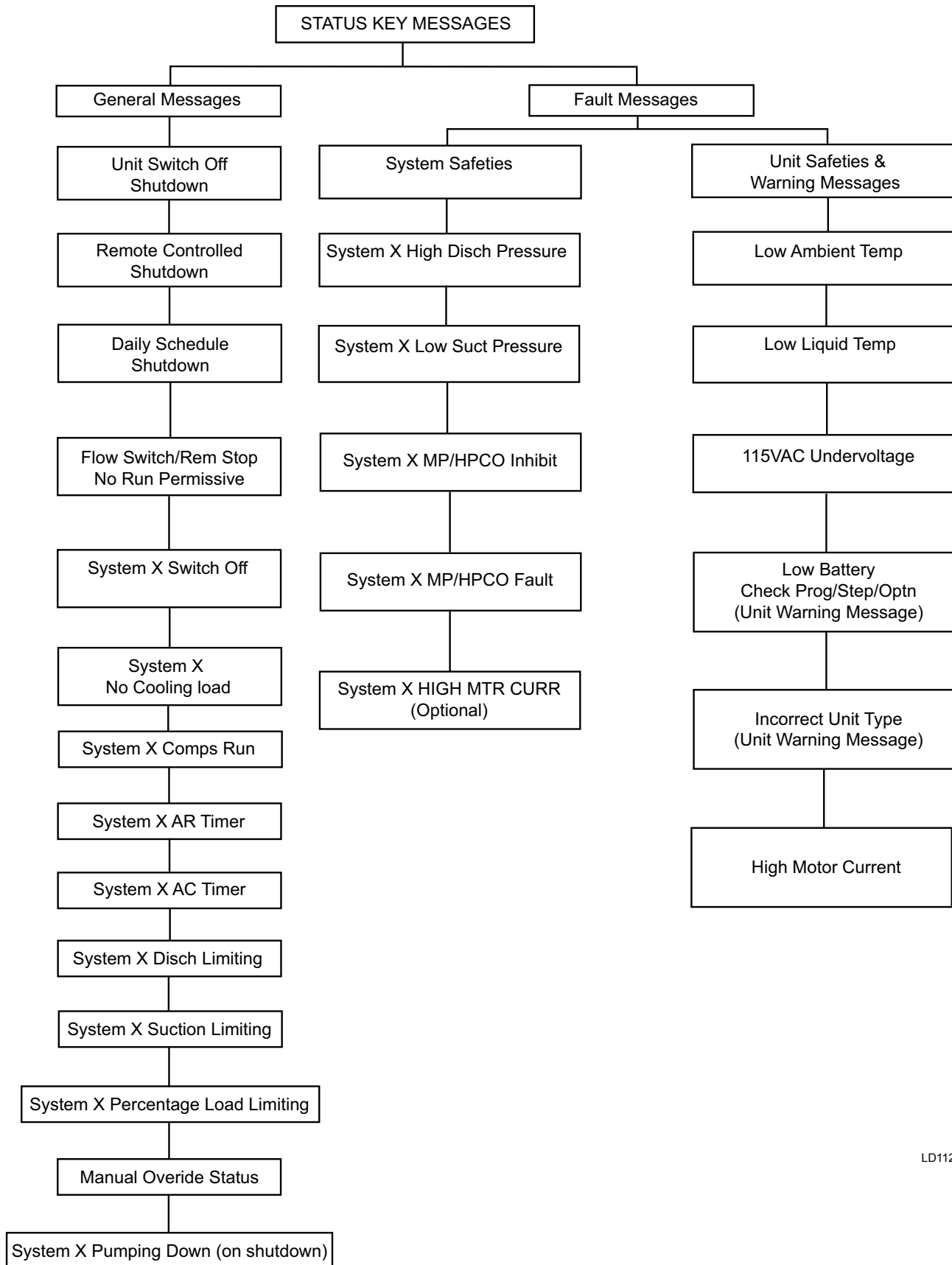

LD11297A

DISPLAY/PRINT KEYS

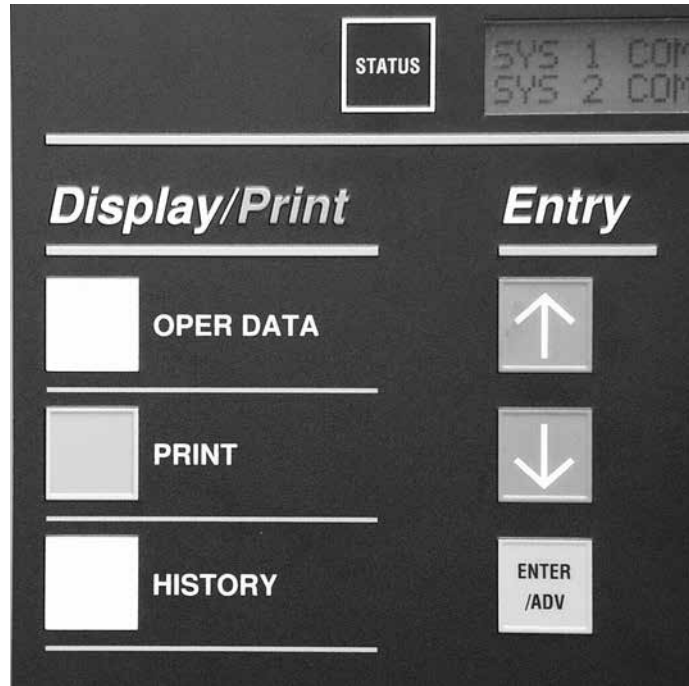

00067VIP

The Display/Print keys allow the user to retrieve system and unit information that is useful for monitoring chiller operation, diagnosing potential problems, troubleshooting, and commissioning the chiller.

System and unit information, unit options, setpoints, and scheduling can also be printed out with the use of a printer. Both real-time and history information are available.

Oper Data Key

The OPER DATA key gives the user access to unit and system operating parameters. When the OPER DATA key is pressed, system parameters will be displayed and remain on the display until another key is pressed. After pressing the OPER DATA key, the various operating data screens can be scrolled through by using the ↑ (UP) and ↓ (DOWN) arrow keys or the ENTER/ADV key located under the “ENTRY” section.

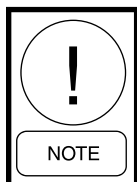

System 2 information will only be displayed for 2 system units.

With the UNIT TYPE set as a liquid chiller (no jumper to J11-12), the following list of operating data screens are viewable under the Oper Data key in the order that they are displayed. The ↓ (DOWN) arrow key scrolls through the displays in the order they appear below:

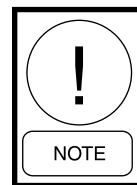

The chiller MUST be set to be a liquid chiller (no jumper to J11-12). DO NOT operate the chiller if not properly set up.

LCHLT = 46.2 °F
RCHLT = 57.4 °F

This display shows chilled leaving and return liquid temperatures. The minimum limit on the display for these parameters are 2.2 °F (-19 °C). The maximum limit on the display is 140 °F (60 °C).

AMBIENT AIR TEMP
= 87.5 °F

This display shows the ambient air temperature. The minimum limit on the display is 0.4 °F (-17.6 °C). The maximum limit on the display is 131.2 °F (55.1 °C).

```
S Y S X S P = 7 2 . 1 P S I G
      D P = 2 2 7 . 0 P S I G
```

```
C O O L I N G D E M A N D
      2 O F 8 S T E P S
```

These displays show suction and discharge pressures for each system. The discharge pressure transducer is optional on some models.

The display of COOLING DEMAND indicates the current “step” in the capacity control scheme when in Return Water Control Mode. The number of available steps are determined by how many compressors are in the unit. In the above display, the “2” does not mean that two compressor are running but only indicates that the capacity control scheme is on step 2 of 8. Capacity Control is covered in more detail in this publication which provides specific information on compressor staging (for Return Water Control only).

If the optional discharge transducer is not installed, the discharge pressure would display 0 PSIG (0 barg).

The minimum limits for the display are:

- Suction Pressure: 0 PSIG (0 barg)
- Discharge Pressure: 0 PSIG (0 barg)

The maximum limits for the display are:

- Suction Pressure: 400 PSIG (27.58 barg)
- Discharge Pressure: 650 PSIG (44.82 barg)

```
T E M P E R R O R X X X . X ° F
T E M P R A T E X X X . X ° F / M
```

The COOLING DEMAND message will be replaced with this message when Leaving Chilled Liquid Control is selected. This message indicates the temperature error and the rate of change of the chilled liquid temperature.

```
S Y S X H O U R S 1 = X X X X X
      2 = X X X X X, 3 = X X X X X
```

```
L E A D S Y S T E M I S
S Y S T E M N U M B E R 2
```

The above two messages will appear sequentially for each system. The first display shows accumulated running hours of each compressor for the specific system. The second message shows the number of starts for each compressor on each system.

This display indicates the current LEAD system. In this example system 2 is the LEAD system, making system 1 the LAG system. The LEAD system can be manually selected or automatic. Refer to the programming under the OPTIONS key. The Lead System display will only appear on a two system unit.



Run times and starts will only be displayed for the actual number of systems and compressors on the unit.

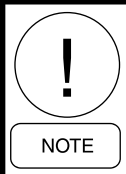

A unit utilizing hot gas bypass should be programmed for MANUAL with system 1 as the lead system. Failure to do so will prevent hot gas operation if system 2 switches to the lead system when programmed for AUTOMATIC LEAD/LAG.

A total of 99,999 hours and starts can be logged before the counter rolls over to “0”.

```
L O A D T I M E R 5 8 S E C
U N L O A D T I M E R 0 S E C
```

```
E V A P O R A T O R H E A T E R
S T A T U S I S = X X X
```

This display of the load and unload timers indicate the time in seconds until the unit can load or unload. Whether the systems loads or unloads is determined by how far the actual liquid temperature is from setpoint. A detailed description of unit loading and unloading is covered under the topic of “Capacity Control” located in Section 8, Unit Operation.

This display indicates the status of the evaporator heater. The evaporator heater is controlled by ambient air temperature. When the ambient temperature drops below 40 °F the heater is turned ON. When the temperature rises above 45 °F the heater is turned OFF. An under voltage condition will keep the heater OFF until full voltage is restored to the system.

```

E V A P O R A T O R   W A T E R
P U M P           S T A T U S       = X X X X
    
```

The evaporator pump dry contacts are energized when any compressor is running, or the unit is not OFF on the daily schedule and the Unit Switch is ON, or the unit has shutdown on a Low Leaving Chilled Liquid fault. However, even if one of above is true, the pump will not run if the micro panel has been powered up for less than 30 seconds or if the pump has run in the last 30 seconds to prevent pump motor overheating.

```

E V A P   P U M P   T O T A L   R U N
H O U R S                               = X X X X X
    
```

The Evaporator Pump Total Run Hours display indicates the total pump run hours. Total hours continually increments similar to Compressor Run Hours. If dual pumps are fitted, run hours indicates total hours on both pumps.

```

A C T I V E   R E M O T E   C T R L
                N O N E
    
```

There are several types of remote systems that can be used to control or monitor the unit. The following messages indicate the type of remote control mode active:

- NONE – no remote control active. Remote monitoring may be via ISN.
- ISN – York Talk via ISN allows remote load limiting and temperature reset through an ISN system.
- LOAD LIM – Load limiting enabled using contact closure.
- PWM TEMP – EMS temperature reset

If the microprocessor is programmed for CURRENT FEEDBACK ONE PER UNIT under the OPTIONS key, the display will show up as the first display prior to the SYS 1 displays. Total chiller current is displayed as shown below:

```

U N I T       A M P S   =   5 4 . 0
                V O L T S   =   1 . 2
    
```

If the microprocessor is programmed for CURRENT FEEDBACK NONE, no current display will appear.

```

S Y S   X   C O M P   S T A T U S
1 = X X X   2 = X X X   3 = X X X
    
```

```

S Y S   X   R U N   T I M E
X X - X X - X X - X X   D - H - M - S
    
```

```

S Y S   X   L L S V   I S   O N
H O T   G A S   S O L   I S   O F F
    
```

```

S Y S   X   F A N   S T A G E   3
    
```

```

S Y S   X   A M P S   =   3 6 . 0
                V O L T S   =   0 . 8
    
```

The preceding five messages will appear sequentially, first for system 1, then for system 2.

The first message indicates the system and the associated compressors which are running.

The second message indicates the system run time in days – hours – minutes – seconds. Please note that this is not accumulated run time but pertains only to the current system cycle.

The third message indicates the system, and whether the liquid line solenoid or EEV pilot solenoid and hot gas solenoid are being turned on by the microboard. Please note that hot gas is not available for system 2, so there is no message pertaining to the hot gas solenoid when system 2 message is displayed.

The fourth message indicates the stage of condenser fan operation that is active.

See the section on Condenser Fan Control in the Unit Operation section for more information.

The fifth message displays current as sensed by the optional current feedback circuitry. The display reads out in amps along with the DC feedback voltage from the module. Current is calculated by:

$$\frac{225A \times \text{Actual Volts}}{5 \text{ Volts}}$$

Individual displays will be present for each system, if CURRENT FEEDBACK ONE PER SYSTEM is programmed under the OPTIONS key. Combined compressor current for each system is displayed.

Oper Data Quick Reference List

The following table is a quick reference list for information available under the OPER DATA key.

TABLE 12 - OPERATION DATA

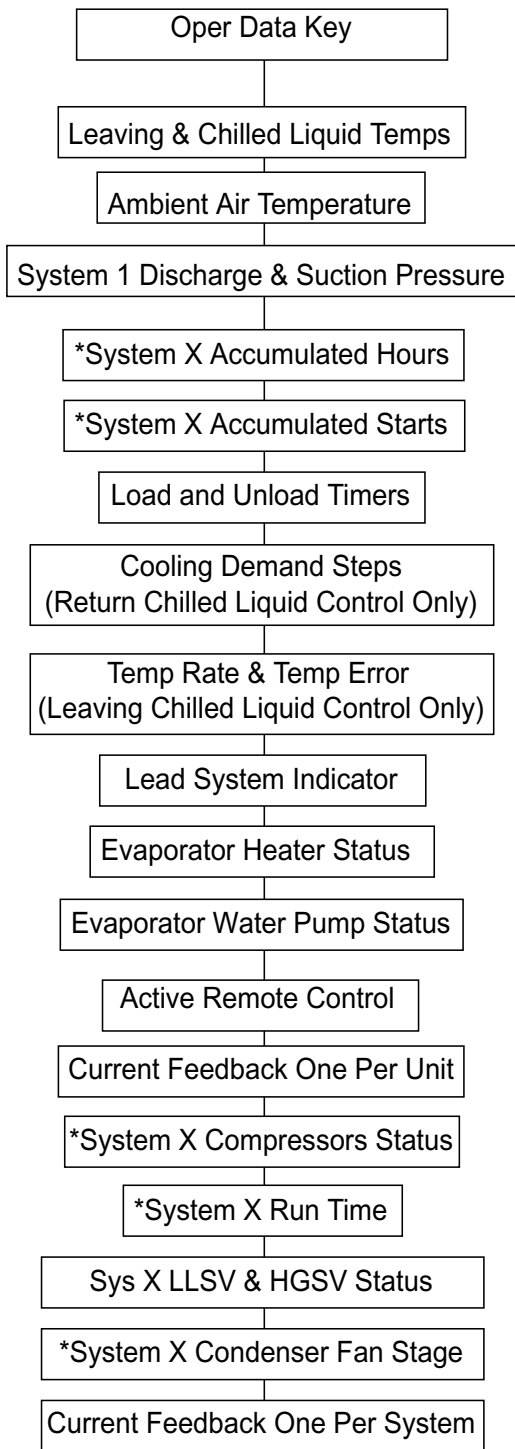

* Block of information repeats for each system

LD12585

Print Key

The PRINT key allows the operator to obtain a printout of real-time system operating data or a history printout of system data at the “instant of the fault” on the last six faults which occurred on the unit. An optional printer is required for the printout.

Operating Data Printout

Pressing the PRINT key and then OPER DATA key allows the operator to obtain a printout of current system operating parameters. When the OPER DATA key is pressed, a snapshot will be taken of system operating conditions and panel programming selections. This data will be temporarily stored in memory and transmission of this data will begin to the printer. A sample Operating Data printout is shown below. (Note: Not all values are printed for all models.)

```

YORK INTERNATIONAL CORPORATION
MILLENNIUM LIQUID CHILLER

UNIT STATUS
2:04PM 01 JAN 09

SYS 1          NO COOLING LOAD
SYS 2          COMPRESSORS RUNNING 2

OPTIONS
CHILLED LIQUID          WATER
AMBIENT CONTROL        STANDARD
LOCAL/REMOTE MODE      REMOTE
CONTROL MODE            LEAVING LIQUID
LEAD/LAG CONTROL        AUTOMATIC
FAN CONTROL             AMB & DSCH PRESS
CURRENT FEEDBACK        NONE
POWER FAILURE RESTART   AUTOMATIC
SOFT START              ENABLED
EXPANSION VALVE         THERMOSTATIC
REMOTE TEMP RESET       4 TO 20 MA

PROGRAM VALUES
DSCH PRESS CUTOFF       570 PSIG
SUCT PRESS CUTOFF       80 PSIG
SUCT PRESS CUT COOLING  42 PSIG
SUCT PRESS CUT HEATING  31 PSIG
LOW AMBIENT CUTOFF      25.0 DEGF
LEAVING LIQUID CUTOFF   25.0 DEGF
ANTI RECYCLE TIME       600 SECS
FAN CONTROL ON PRESS    425 PSIG
FAN DIFF OFF PRESS      125 PSIG
NUMBER OF COMPRESSORS   6
NUMBER OF FANS PER SYSTEM 4
UNIT TRIP VOLTS         3.0
REFRIGERANT TYPE        R-22
DEFROST INIT TEMP       41.0 DEGF
DEFROST INITIATION TIME 60MIN
DEFROST TERMINATION TIME 3MIN
BIVALENT HEAT DELAY TIME 30 MIN
REMOTE UNIT ID PROGRAMMED 2
YORK HYDRO KIT PUMPS    1 (410a)
PUMP TOTAL RUN HOURS    XXXXX (410a)
    
```

```

UNIT DATA
RETURN LIQUID TEMP      58.2 DEGF
LEAVING LIQUID TEMP     53.0 DEGF
DISCHARGE AIR TEMP      55.3 DEGF
COOLING RANGE  42.0 +/- 2.0 DEGF
HEATING RANGE 122.0 +/- 2.0 DEGF
SYS 1 SETPOINT    70 +/- 3 PSIG
SYS 2 SETPOINT    70 +/- 3 PSIG
REMOTE SETPOINT    44.0 DEGF
AMBIENT AIR TEMP   74.8 DEGF
LEAD SYSTEM        SYS 2
EVAPORATOR PUMP    ON
EVAPORATOR HEATER  OFF
ACTIVE REMOTE CONTROL  NONE
LAST DEFROST SYS X DURATION XXXS
TIME TO SYS X DEFROST  XX MIN
BIVALENT DELAY REMAINING XX MIN
UNIT  XXX.X AMPS      X.X VOLTS
SOFTWARE VERSION    C.M02.13.00
    
```

```

SYSTEM 1 DATA
COMP STATUS  1=OFF 2=OFF 3=OFF
RUN TIME     0- 0- 0- 0 D-H-M-S
TIME YYYYYYY 0- 0- 0- 0 D-H-M-S
LAST STATE   YYYYYYY
SUCTION PRESSURE 105 PSIG
DISCHARGE PRESSURE 315 PSIG
SUCTION TEMPERATURE 46.0 DEGF
SAT SUCTION TEMP 34.0 DEGF
SUCTION SUPERHEAT 12.0 DEGF
COOLER INLET REFRIG 31.6 DEGF
DEFROST TEMPERATURE 52.8 DEGF
LIQUID LINE SOLENOID OFF
MODE SOLENOID OFF
HOT GAS BYPASS VALVE OFF
CONDENSER FAN STAGE OFF
EEV OUTPUT 0.0 %
SYSTEM XXX.X AMPS X.X VOLTS
    
```

```

SYSTEM 2 DATA
COMP STATUS  1=ON, 2=OFF, 3=ON
RUN TIME     0-0-1-46 D-H-M-S
TIME YYYYYYY 0-0-0-0 D-H-M-S
LAST STATE   YYYYYYY
SUCTION PRESSURE 110 PSIG
DISCHARGE PRESSURE 320 PSIG
SUCTION TEMPERATURE 49.3 DEGF
SAT SUCTION TEMP 36.0 DEGF
SUCTION SUPERHEAT 13.3 DEGF
COOLER INLET REFRIG 31.6 DEGF
DEFROST TEMPERATURE 52.8 DEGF
LIQUID LINE SOLENOID ON
MODE SOLENOID ON
CONDENSER FAN STAGE 3
EEV OUTPUT 63.2%
SYSTEM XXX.X AMPS X.X VOLTS
    
```

```

DAILY SCHEDULE
S M T W T F S      *=HOLIDAY
SUN START=00:00AM STOP=00:00AM
MON START=00:00AM STOP=00:00AM
TUE START=00:00AM STOP=00:00AM
WED START=00:00AM STOP=00:00AM
THU START=00:00AM STOP=00:00AM
FRI START=00:00AM STOP=00:00AM
SAT START=00:00AM STOP=00:00AM
HOL START=00:00AM STOP=00:00AM
    
```

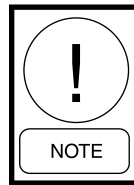

See Service And Troubleshooting section for Printer Installation information.

History Printout

Pressing the PRINT key and then the HISTORY key allows the operator to obtain a printout of information relating to the last 9 Safety Shutdowns which occurred. The information is stored at the instant of the fault, regardless of whether the fault caused a lockout to occur. The information is also not affected by power failures (long-term internal memory battery backup is built into the circuit board) or manual resetting of a fault lockout.

When the HISTORY key is pressed, a printout is transmitted of all system operating conditions which were stored at the “instant the fault occurred” for each of the 9 Safety Shutdowns buffers. The printout will begin with the most recent fault which occurred. The most recent fault will always be stored as Safety Shutdown No. 1. identically formatted fault information will then be printed for the remaining safety shutdowns.

Information contained in the safety shutdown buffers is very important when attempting to troubleshoot a system problem. This data reflects the system conditions at the instant the fault occurred and often reveals other system conditions which actually caused the safety threshold to be exceeded.

The history printout is similar to the operational data printout shown in the previous section. The differences are in the header and the schedule information. The daily schedule is not printed in a history print.

One example history buffer printout is shown following. The data part of the printout will be exactly the same as the operational data print so it is not repeated here. The difference is that the Daily Schedule is not printed in the history print and the header will be as follows.

```

YORK INTERNATIONAL CORPORATION
MILLENNIUM LIQUID CHILLER

SAFETY SHUTDOWN NUMBER 1
SHUTDOWN @ 3:56PM 29 JAN 09

SYS 1 HIGH DSCH PRESS SHUTDOWN
SYS 2 NO FAULTS
    
```

History Displays

The HISTORY key gives the user access to many unit and system operating parameters at the time of a unit or system safety shutdown. When the HISTORY key is pressed the following message is displayed.

```

DISPLAY SAFETY SHUT-
DOWN NO . 1 ( 1 TO 9 )
    
```

While this message is displayed, the ↑ (UP) arrow key can be used to select any of the six history buffers. Buffer number 1 is the most recent, and buffer number 6 is the oldest safety shutdown that was saved.

After selecting the shutdown number, pressing the ENTER key displays the following message which shows when the shutdown occurred.

```

SHUTDOWN OCCURRED
03 : 56 PM 29 JAN 02
    
```

The ↑ (UP) and ↓ (DOWN) arrow keys are used to scroll forward and backward through the history buffer to display the shutdown conditions stored at the instant the fault occurred. The ↓ (DOWN) arrow key scrolls through the displays in the order they appear below:

```

UNIT FAULT :
LOW LIQUID TEMP
    
```

Displays the type of fault that occurred.

```

UNIT TYPE
LIQUID CHILLER
    
```

Displays the type of chiller; Liquid, Condensing Unit or Heat Pump.

```

CHILLED LIQUID
XXXXX
    
```

Displays the chilled liquid type; Water or Glycol.

```

AMBIENT CONTROL
XXXXXXXXXX
    
```

Displays the type of Ambient Control; Standard or Low Ambient.

```

LOCAL / REMOTE MODE
XXXXXXXXXX
    
```

Displays Local or Remote control selection.

```

CONTROL MODE
LEAVING LIQUID
    
```

Displays the type of chilled liquid control; Leaving or Return.

```

LEAD / LAG CONTROL
XXXXXXXXXX
    
```

Displays the type of lead/lag control; Manual System 1, Manual System 2 or Automatic. This is only selectable on 2-system chillers.

```

FAN CONTROL
DISCHARGE PRESSURE
    
```

Displays the type of fan control; Discharge Pressure or Ambient and Discharge Pressure.

```

MANUAL OVERRIDE MODE
XXXXXXXXXX
    
```

Displays whether Manual Override was Enabled or Disabled.

```

CURRENT FEEDBACK
XXXXXXXXXXXXXXXXXX
    
```

Displays type of Current Feedback utilized.

```

SOFT START
XXXXXX
    
```

Displays whether the optional European Soft Start was installed and selected.

```

DISCHARGE PRESSURE
CUTOUT = XXXX PSIG
    
```

Displays the programmed Discharge Pressure Cutout.

```

SUCTION PRESSURE
CUTOUT = XXXX PSIG
    
```

Displays the programmed Suction Pressure Cutout.

```

LOW AMBIENT TEMP
CUTOUT = XXX.X °F
    
```

Displays the programmed Low Ambient Cutout.

LEAVING LIQUID TEMP
CUTOFF = XXX.X °F

Displays the Leaving Liquid Temperature Cutout programmed.

FAN CONTROL ON
PRESSURE = XXX PSIG

Displays the programmed Fan On Pressure.

FAN DIFFERENTIAL OFF
PRESSURE = PSIG

Displays the programmed Fan Off Differential.

SYS 1 TRIP VOLTS
= X.X VOLTS

Displays the programmed High Current Trip Voltage.

SYS 2 TRIP VOLTS
= X.X VOLTS

Displays the programmed High Current Trip Voltage.

YORK HYDRO
KIT PUMPS = X

Indicates the Pump Control option is selected.

LCHLT = XXX.X °F
RCHLT = XXX.X °F

Displays the Leaving and Return Chilled Liquid Temperature at the time of the fault.

SETPOINT = XXX.X °F
RANGE = +/- °F

Displays the programmed Setpoint and Range, if the chiller is programmed for leaving chilled liquid control.

SETPOINT = XXX.X °F
RANGE = +XX.X °F

Displays the programmed Setpoint and Range, if the chiller is programmed for return chilled liquid control.

AMBIENT AIR TEMP
= XXX.X °F

Displays the Ambient Temperature at the time of the fault.

LEAD SYSTEM IS
SYSTEM NUMBER X

Displays which system is in the lead at the time of the fault.

EVAPORATOR HEATER
STATUS IS XXX

Displays status of the Evaporator Heater at the time of the fault.

EVAPORATOR WATER
PUMP STATUS XXXX

Displays status of Evaporator Water Pump at the time of fault. Status may read ON, OFF or trip.

EVAP PUMP TOTAL RUN
HOURS = XXXX

Evap Pump total run hours at the time of fault.

ACTIVE REMOTE CTRL
XXXX

Displays whether Remote Chiller Control was active when the fault occurred.

UNIT ACTUAL AMPS
= XXX.X AMPS

7

This is only displayed when the Current Feedback Option is one per unit.

SYS X COMP STATUS
1 = XXX 2 = XXX 3 = XXX

Displays which Compressors were running in the system when the fault occurred.

SYS X RUN TIME
XX-XX-XX-XX D-H-M-S

Displays the system run time when the fault occurred.

SYS X SP = XXXX PSIG
DP = XXXX PSIG

Displays the system Suction and Discharge Pressure of the time of the fault.

```
S Y S X S U C T = X X X . X ° F
S A T S U C T = X X X . X ° F
```

Displays the System Suction Temperature and Saturated Suction Temperature when an EEV is installed.

```
S Y S X L L S V I S X X X
H O T G A S S O L I S X X X
```

Displays whether the System Liquid Line Solenoid or Hot Gas Solenoid was energized at the time of the fault.

```
S Y S X F A N S T A G E X X X
```

Displays the number of Fan Stages in the system active at the time of the fault.

```
S Y S X A C T U A L A M P S
= X X X . X A M P S
```

Displays the System Amperage (calculated approximately) at the time of the fault.

For this message to appear, CURRENT FEEDBACK ONE PER SYSTEM must be programmed under the OPTIONS key. If the microprocessor is programmed as one CURRENT FEEDBACK ONE PER UNIT un-

der the PROGRAM key, the display will be the first display prior to the SYS 1 info. If the microprocessor is programmed for CURRENT FEEDBACK NONE, no current display will appear.

Displays for System 1 starting with SYS X NUMBER OF COMPS RUNNING X through SYS X AMPS = XXX.X VOLTS = X.X will be displayed first, followed by displays for System 2.

Further explanation of the above displays are covered under the STATUS, OPER DATA, COOLING SETPOINTS, PROGRAM, and OPTIONS keys.

Software Version

The software version may be viewed by first pressing the HISTORY key and then repeatedly pressing the ↓ (DOWN) arrow key until you scroll past the first history buffer choice.

```
D I S P L A Y S A F E T Y S H U T -
D O W N N O . 1 ( 1 T O 6 )
```

After the ↓ (DOWN) arrow key is pressed again, the software version will appear.

```
C O N T R O L C . M X X . Z Z . Y Y
I / O C . M X X . 1 8 . Y Y
```

ENTRY KEYS

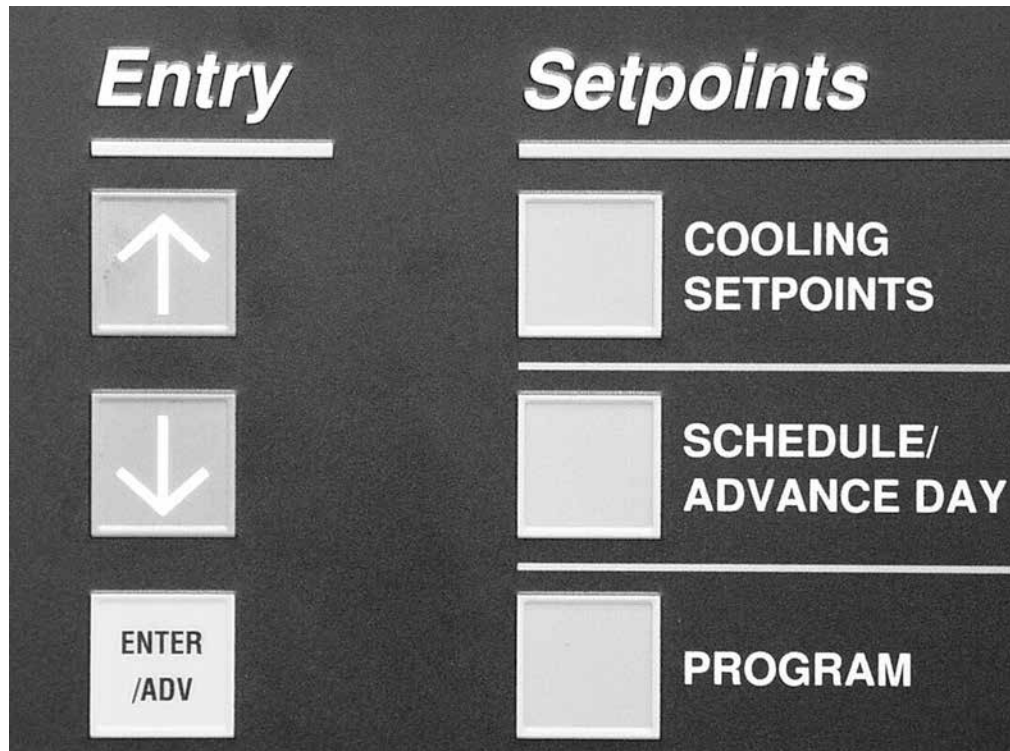

00068VIP

7

The Entry Keys allows the user to view, change programmed values. The ENTRY keys consist of an ↑ (UP) arrow key, ↓ (DOWN) arrow key, and an ENTER/ADV key.

Up and Down Arrow Keys

Used in conjunction with the OPER DATA, HISTORY, COOLING SETPOINTS, SCHEDULE/ADVANCE DAY, OPTIONS and CLOCK keys, the ↑ (UP) and ↓ (DOWN) arrow keys allow the user to scroll through the various data screens. Refer to the section on DISPLAY/PRINT keys for specific information on the displayed information and specific use of the ↑ (UP) and ↓ (DOWN) arrow keys.

The ↑ (UP) arrow key, and ↓ (DOWN) arrow key are also used for programming the control panel such as

changing numerical or text values when programming cooling setpoints, setting the daily schedule, changing safety setpoints, chiller options, and setting the clock.

Enter/Adv Key

The ENTER/ADV key must be pushed after any change is made to the cooling setpoints, daily schedule, safety setpoints, chiller options, and the clock. Pressing this key “enters” the new values into memory. If the ENTER/ADV key is not pressed after a value is changed, the changes will not be “entered” and the original values will be used to control the chiller.

Programming and a description on the use of the ↑ (UP) arrow key, and ↓ (DOWN) arrow, and ENTER/ADV keys are covered in detail under the SETPOINTS, and UNIT keys.

SETPOINTS KEYS

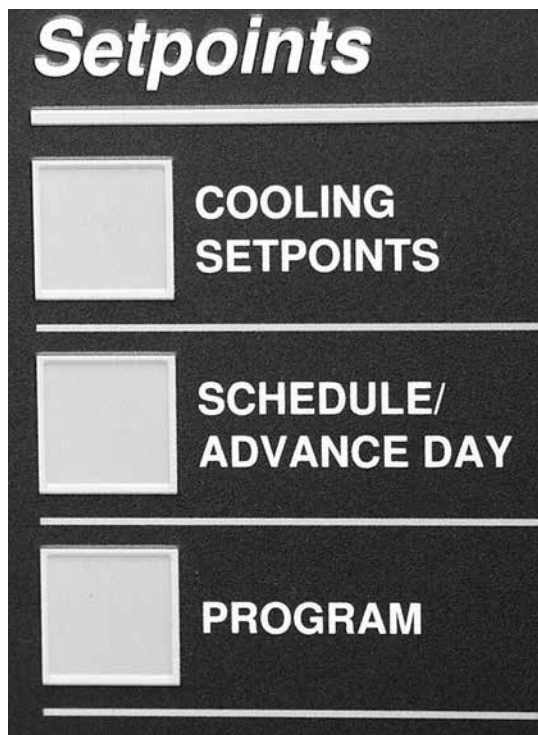

00069VIP

Programming of the cooling setpoints, daily schedule, and safeties is accomplished by using the keys located under the Setpoints section.

The three keys involved are labeled COOLING SETPOINTS, SCHEDULE/ADVANCE DAY, and PROGRAM.

Following are instructions for programming the respective setpoints. The same instruction should be used to view the setpoints with the exception that the setpoint will not be changed.

Cooling Setpoints

The Cooling Setpoint and Range can be programmed by pressing the COOLING SETPOINTS key. The cooling mode (leaving chilled liquid or return chilled liquid) will be displayed for a few seconds, and the setpoint display entry screen will appear.

Leaving Chilled Liquid Control

```

SETPOINT = 45.0 °F
RANGE = +/- 2.0 °F
  
```

The above message shows the current chilled water temperature Setpoint at 45.0 °F (notice the cursor positioned under the number 0). Pressing either the ↑ (UP) or ↓ (DOWN) arrow will change the setpoint in 0.5 °F increments. After using the ↑ (UP) or ↓ (DOWN) arrow keys to adjust to the desired setpoint, the ENTER/ADV key must be pressed to enter this number into memory and advance to the RANGE SETPOINT.

Entry of the setpoint will be indicated by the cursor moving under the current RANGE setpoint. The ↑ (UP) and ↓ (DOWN) arrow keys are used to set the RANGE, in 0.5 °F increments, to the desired RANGE setpoint. After adjusting the setpoint, the ENTER/ADV key must be pressed to enter the data into memory.

Notice that the RANGE was programmed for plus or minus X.X° F. This indicates the SETPOINT to be in the center of the control range. If the control mode has been programmed for RETURN LIQUID control, the message below would be displayed in place of the previous message.

When in leaving chilled liquid temperature control, the microprocessor will attempt to control the leaving water temperature within the temperature range of the setpoint plus or minus the range. In the above example, control will be in the range of 43 to 47 °F.

Return Chilled Liquid Control

```

SETPOINT = 45.0 °F
RANGE = +10.0 °F
    
```

In return chilled liquid control, the range no longer has a plus or minus X.X °F, but only a plus X.X °F RANGE setpoint. This indicates that the setpoint is not centered within the RANGE but could be described as the bottom of the control range. A listing of the limits and the programmable values for the COOLING SETPOINTS are shown in Table 13.

The SETPOINT and RANGE displays just described were based on LOCAL control. If the unit was programmed for REMOTE control (under the OPTIONS key), the above programmed setpoints would have no effect.

When in return chilled liquid temperature control, the microprocessor will turn all compressors OFF at setpoint and will turn compressors on as return chilled liquid temperature rises. All compressors will be ON at setpoint plus the range. If the range equals the temperature drop across the evaporator when fully loaded, the leaving chilled liquid temperature will remain near the setpoint plus or minus a few degrees as the chiller loads and unloads according to return chilled liquid temperature.

Both LEAVING and RETURN control are described in detail under the section on Capacity Control.

Remote Setpoint Control

Pressing the COOLING SETPOINTS key a second time will display the remote setpoint and cooling range. This display automatically updates about every 2 seconds. Notice that these setpoints are not “locally” programmable, but are controlled by a remote device such as an ISN control, remote reset option board, or remote PWM signal. These setpoints would only be valid if the unit was operating in the REMOTE mode.

The following messages illustrate both leaving chilled liquid control and return chilled liquid control respectively.

```

REM SETP = 44.0 °F
RANGE = +/- 2.0 °F
    
```

(leaving chilled liquid control)

TABLE 13 - COOLING SETPOINTS, PROGRAMMABLE LIMITS AND DEFAULTS

SETPOINT KEY	MODE	LOW LIMIT	HIGH LIMIT	DEFAULT
LEAVING CHILLED LIQUID SETPOINT	WATER COOLING	40.0°F 4.4°C	**70.0°F 21.1°C	44.0°F 6.7°C
	GLYCOL COOLING	*10.0°F -12.2°C	**70.0°F 21.1°C	44.0°F 6.7°C
LEAVING CHILLED LIQUID CONTROL RANGE	—	1.5°F 0.8°C	2.5°F 1.4°C	2.0°F 1.1°C
RETURNED CHILLED LIQUID SETPOINT	WATER COOLING *	40.0°F 4.4°C	70.0°F 21.1°C	44.0°F 6.7°C
	GLYCOL COOLING *	10.0°F -12.2°C	70.0°F 21.1°C	44.0°F 6.7°C
RETURN CHILLED LIQUID CONTROL RANGE	—	4.0°F 2.2°C	20.0°F 11.1°C	10.0°F 5.6°C
MAX EMS-PWM REMOTE TEMPERATURE RESET	—	2°F 1.0°C	40°F 22.0°C	20°F 11.0°C

* Refer to Engineering Guide for operation below 30°F (-1.1°C). Alternate thermal expansion valves must be used below 30°F (-1.1°C).
 * When using glycol, Leaving Chilled Liquid Setpoint should not be set below 20°F (-6.7°C).
 ** Do not exceed 55°F (12.8°C) setpoint before contacting the nearest Johnson Controls Office for application guidelines.

```
REM SETP = 44.0 ° F
RANGE = +10.0 ° F
```

(return chilled liquid control)

The low limit, high limit, and default values for the keys under “SETPOINTS” are listed in Table 13.

Pressing the COOLING SETPOINTS key a third time will bring up the display that allows the Maximum EMS-PWM Temperature Reset to be programmed. This message is shown below.

```
MAX EMS - PWM REMOTE
TEMP RESET = +20 ° F
```

The Temperature Reset value is the maximum allowable remote reset of the temperature setpoint. The setpoint can be reset upwards by the use of an Energy Management System or from the Temperature Reset Option Board. See page 200 for a detailed explanation of this feature.

As with the other setpoints, the ↑ (Up) arrow and ↓ (Down) arrow keys are used to change the Temperature Reset value. After using the ↑ (UP) and ↓ (DOWN) arrows to adjust to the desired setpoint, the ENTER/ADV key must be pressed to enter this number into memory.

SCHEDULE/ADVANCE DAY KEY

The “Schedule” is a seven day daily schedule that allows one start/stop time per day. The schedule can be programmed Monday through Sunday with an alternate holiday schedule available. If no start/stop times are programmed, the unit will run on demand, providing the chiller is not shut off on a unit or system shutdown. The daily schedule is considered “not programmed” when the times in the schedule are all zeros (00:00 AM).

To set the schedule, press the SCHEDULE/ADVANCE DAY key. The display will immediately show the following display.

```
MON START = 00:00 AM
STOP = 00:00 AM
```

The line under the 0 is the cursor. If the value is wrong, it may be changed by using the ↑ (UP) and ↓ (DOWN) arrow keys until correct. Pressing the ENTER/ADV

key will enter the times and then move the cursor to the minute box. The operation is then repeated if necessary. This process may be followed until the hour, minutes, and meridian (AM or PM) of both the START and STOP points are set. After changing the meridian of the stop time, pressing the ENTER/ADV key will advance the schedule to the next day.

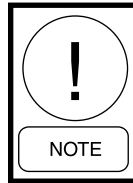

Whenever the daily schedule is changed for Monday, all the other days will change to the new Monday schedule. This means if the Monday times are not applicable for the whole week then the exceptional days would need to be reprogrammed to the desired schedule.

To page to a specific day, press the SCHEDULE/ADVANCE DAY key until the desired day appears. The start and stop time of each day may be programmed differently using the ↑ (UP) and ↓ (DOWN) arrow, and ENTER/ADV keys.

After SUN (Sunday) schedule appears on the display a subsequent press of the SCHEDULE/ADVANCE DAY key will display the Holiday schedule. This is a two part display. The first reads:

```
HOL START = 00:00 AM
STOP = 00:00 AM
```

The times may be set using the same procedure as described above for the days of the week. After changing the meridian of the stop time, pressing the ENTER/ADV key will advance the schedule to the following display:

```
S _ M T W T F S
HOLIDAY NOTED BY *
```

The line below the empty space next to the S is the cursor and will move to the next empty space when the ENTER/ADV key is pressed. To set the Holiday, the cursor is moved to the space following the day of the week of the holiday and the ↑ (UP) arrow key is pressed. An * will appear in the space signifying that day as a holiday. The * can be removed by pressing the ↓ (DOWN) arrow key.

The Holiday schedule must be programmed weekly – once the Holiday schedule runs, it will revert to the normal daily schedule.

PROGRAM KEY

There are several operating parameters under the PROGRAM key that are programmable. These setpoints can be changed by pressing the PROGRAM key, and then the ENTER/ADV key to enter Program Mode. Continuing to press the ENTER/ADV key will display each operating parameter. While a particular parameter is being displayed, the ↑ (UP) and ↓ (DOWN) arrow keys can be used to change the value. After the value is changed, the ENTER/ADV key must be pressed to enter the data into memory. Table 15 shows the programmable limits and default values for each operating parameter.

Following are the displays for the programmable values in the order they appear:

**D I S C H A R G E P R E S S U R E
C U T O U T = 3 9 5 P S I G**

DISCHARGE PRESSURE CUTOUT is the discharge pressure at which the system will shutdown as moni-

tored by the optional discharge transducer. This is a software shutdown that acts as a backup for the mechanical high pressure switch located in the refrigerant circuit. The system can restart when the discharge pressure drops 40 PSIG (2.76 barg) below the cutout point.

If the optional discharge pressure transducer is not installed, this programmable safety would not apply. It should be noted that every system has a mechanical high pressure cutout that protects against excessive high discharge pressure regardless of whether or not the optional discharge pressure is installed.

**S U C T I O N P R E S S U R E
C U T O U T = 8 0 . 0 P S I G**

The SUCTION PRESSURE CUTOUT protects the chiller from an evaporator freeze-up. If the suction pressure drops below the cutout point, the system will shut down. Typically, the cutout should be set to 80 PSIG (5.52 Bars) form water cooling.

TABLE 14 - PROGRAM KEY LIMITS AND DEFAULT

PROGRAM VALUE	MODE	LOW LIMIT	HIGH LIMIT	DEFAULT
DISCHARGE PRESSURE CUTOUT	—	325 PSIG	575 PSIG	570 PSIG
		22.4 BARG	39.6 BARG	39.3 BARG
SUCTION PRESSURE CUTOUT	WATER COOLING	80.0 PSIG	120.0 PSIG	80.0 PSIG
		5.52 BARG	8.27 BARG	5.52 BARG
	GLYCOL COOLING	42.0 PSIG	70.0 PSIG	44.0 PSIG
		2.9 BARG	4.83 BARG	3.03 BARG
LOW AMBIENT TEMPERATURE CUTOUT	STANDARD AMBIENT	25.0 °F	60.0 °F	25.0 °F
		-3.9 °C	15.6 °C	-3.9 °C
	LOW AMBIENT	0 °F	60.0 °F	25.0 °F
		-17.8 °C	15.6 °C	-3.9 °C
LEAVING CHILLED LIQUID TEMPERATURE CUTOUT	WATER COOLING	—	—	36 °F
		—	—	2.2 °C
	GLYCOL COOLING	-1.0 °F	36.0 °F	36.0 °F
		-18.3 °C	2.2 °C	2.2 °C
ANTI-RECYCLE TIMER	—	300 SEC.	600 SEC.	600 SEC.
FAN CONTROL ON PRESSURE (NOT APPLICABLE TO A YCRL)	—	360 PSIG	485 PSIG	385 PSIG
		24.8 BARG	33.4 BARG	26.5 BARG
FAN DIFFERENTIAL OFF PRESSURE	—	80 PSID	160 PSID	125 PSID
		5.51 BARD	11.03 BARD*	8.62 BARD
TOTAL NUMBER OF COMPRESSORS	SINGLE SYSTEM	2	3	3
	DUAL SYSTEM	4	6	6
NUMBER OF FANS PER SYSTEM	—	2	4	3
UNIT/SYSTEM TRIP VOLTS	CURRENT FEEDBACK	0.5 VOLTS	4.5 VOLTS	2.5 VOLTS
REMOTE UNIT ID	—	0	7	0

* The minimum discharge pressure allowed is 235 PSIG. The Fan Differential Off Pressure High Limit will be lowered (reduced) to prevent going below 235 PSIG based on where the fan control On Pressure is programmed.

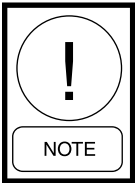

There are some exceptions when the suction pressure is permitted to temporarily drop below the cutout point. Details are explained under the topic of System Safeties.

**LOW AMBIENT TEMP
CUTOUT = 25.0 °F**

The LOW AMBIENT TEMP CUTOUT allows the user to select the chiller outside ambient temperature cutout point. If the ambient falls below this point, the chiller will shut down. Restart can occur when temperature rises 2 °F (1.11 °C) above the cutout setpoint.

**LEAVING LIQUID TEMP
CUTOUT = 36.0 °F**

The LEAVING LIQUID TEMP CUTOUT protects the chiller from an evaporator freeze-up. Anytime the leaving chilled liquid temperature drops to the cutout point, the chiller shuts down. Restart will be permitted when the leaving chilled liquid temperature rises 2 °F (1.11 °C) above the cutout setpoint.

When water cooling mode is programmed (OPTIONS key), the value is fixed at 36.0 °F (2.22 °C) and cannot be changed. Glycol cooling mode can be programmed to values listed in Table 13.

**ANTI RECYCLE TIMER
= 600 SEC**

The programmable anti-recycle timer assures that systems do not short cycle, and the compressor motors have sufficient time to dissipate heat after a start. This timer is programmable under the PROGRAM key between 300 and 600 seconds. Whenever possible, to reduce cycling and motor heating, the anti-recycle timer should be adjusted as high as possible. The programmable anti-recycle timer starts the timer when the first compressor in a system starts. The timer begins to count down. If all the compressors in the circuit cycle OFF, a compressor within the circuit will not be permitted to start until the anti-recycle timer has timed out. If the lead system has run for less than 5 minutes, 3 times in a row, the anti-recycle timer will be extended to 10 minutes, if currently programmed for less than 10 minutes.

**FAN CONTROL ON
PRESSURE = XXX PSIG**

The FAN CONTROL ON-PRESSURE is the programmed pressure value that is used to stage the condenser fans ON, in relation to discharge pressure. Refer to Condenser Fan Control in the UNIT OPERATION section and Tables 19, 20, 21 and 22.

**FAN DIFFERENTIAL OFF
PRESSURE = XXX PSIG**

The FAN DIFFERENTIAL OFF PRESSURE is the programmed differential pressure value that is used to stage the condenser fans OFF, in relation to discharge pressure. Refer to Condenser Fan Control in the UNIT OPERATION section and Tables 19, 20, 21 and 22.

**TOTAL NUMBER OF
COMPRESSORS = 6**

The TOTAL NUMBER OF COMPRESSORS is the total quantity of compressors in the chiller, and determines the stages of cooling available. Note in Table 13, the chiller may have single or dual systems. Single system units can have 2 or 3 compressors, while dual system units may have 4 or 6 compressors.

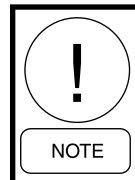

This MUST be programmed correctly to assure proper chiller operation.

A single system chiller MUST have a jumper between terminals J9-7 and +24V on the I/O board. This connection can be made between terminals 13 and 17 on terminal block CTB1. If the jumper is not installed, the unit will act as a 2-system chiller. The jumper is only checked by the microprocessor at unit power-up. If the jumper is removed, power must be removed and re-applied to register the change in memory.

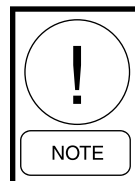

This MUST be programmed correctly to assure proper chiller operation.

**NUMBER OF FANS
PER SYSTEM = X**

The NUMBER OF FANS PER SYSTEM must be programmed as needed to match the number of fans on each system.

**SYS X TRIP VOLTS
= X.X VOLTS**

**UNIT TRIP VOLTS
= X.X VOLTS**

Depending on the option, the trip voltage for a specific system or unit high current trip can be programmed. It also calibrates the current read-out under the OPER DATA key. The approximate programmed value is calculated using the following formulas.

System Trip Volts

For individual system high current trip programming on chillers:

- Add the sum of the compressor and fan RLA's in the system.
- Multiply the sum by 1.25.
- Divide by 225A.
- The resulting voltage is the value that should be programmed.

For example, if fan and compressor RLA's total 100A:

$$\frac{5V \times 100A}{225A} \times 1.25 = \frac{625VA}{225A} = 2.8V$$

The programmed value will be 2.8V. A similar calculation and programming will be necessary for the other system in a 2-system chiller.

Unit Trip Volts

For total chiller high current trip programming on 460VAC chillers:

- Add the sum of all the compressor and fan RLA's in the chiller.
- Multiply the sum by 1.25.
- Divide by 225A.
- The resulting voltage is the value that should be programmed.

For example, if fan and compressor RLA's total 180A:

$$\frac{5V \times 180A}{225A} \times 1.25 = \frac{1125VA}{225A} = 5.0V$$

The programmed value will be 5.0V.

**REMOTE UNIT ID
PROGRAMMED = X**

When communications is required with a BAS or OptiView Panel, individual unit IDs are necessary for communications with specific chillers on a single RS-485 line. ID 0-7 is selectable.

TABLE 15 - SETPOINTS QUICK REFERENCE LIST

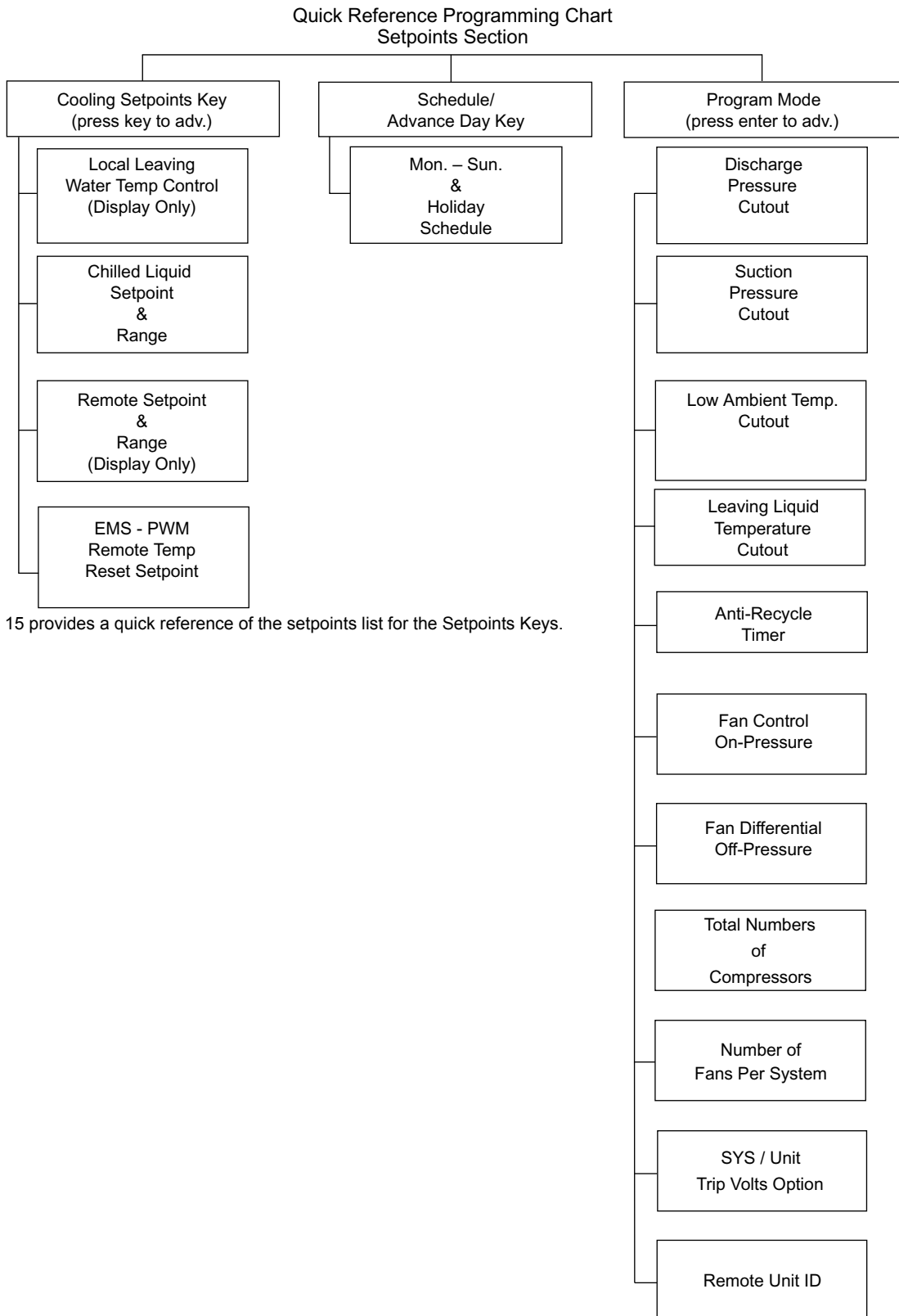
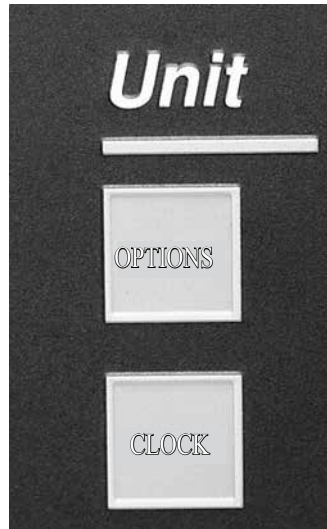

Table 15 provides a quick reference of the setpoints list for the Setpoints Keys.

UNIT KEYS



00070VIP

Options Key

There are many user programmable options under the OPTIONS key. The OPTIONS key is used to scroll through the list of options by repeatedly pressing the OPTIONS key. After the selected option has been displayed, the ↑ (UP) and ↓ (DOWN) arrow keys are then used to change that particular option. After the option is changed, the ENTER/ADV key must be pressed to enter the data into memory.

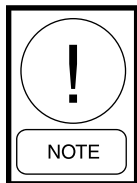

Many of the “Options” displayed are only programmable under the “Service Mode” and not under the OPTIONS key. Options only programmable under the “Service Mode” are noted in the details describing the option.

Table 16 shows the programmable options. Following are the displays in the order they appear:

Option 1 – Language



English, Spanish, French, German, and Italian can be programmed.

Option 2 – System Switches: (two system units only)

(Single System Display is similar)



This allows both systems to run

or



This turns system 2 OFF



This turns system 1 OFF

or



This turns systems 1 and 2 OFF

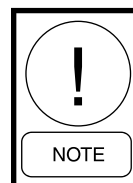

Turning a system OFF with its system switch allows a pumpdown to be performed prior to shutdown.

Option 3 – Chilled Liquid Cooling Type:



The chilled liquid is water. The Cooling Setpoint can be programmed from 40 °F to 70 °F (4.4 °C to 21.1 °C)

or



The chilled liquid is glycol. The Cooling Setpoint can be programmed from 10 °F to 70 °F (-12.2 °C to 21.1 °C).

Option 4 – Ambient Control Type

**A M B I E N T C O N T R O L
S T A N D A R D**

The low ambient cutout is adjustable from 25 °F to 60 °F (-3.9 °C to 15.6 °C).

or

**A M B I E N T C O N T R O L
L O W A M B I E N T**

The low ambient cutout is programmable down to 0 °F (-17.8 °C).

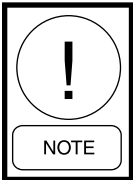

*A low ambient kit **MUST** be installed for this option to be chosen. If the kit is **NOT** installed, and low ambient is selected, low pressure faults and compressor damage may occur.*

Option 5 – Local/Remote Control Type

**L O C A L / R E M O T E M O D E L
L O C A L**

When programmed for LOCAL, an ISN or RCC control can be used to monitor only. The micro panel will operate on locally programmed values and ignore all commands from remote devices, or through the RS-485 inputs. The chiller will communicate and send data to the remote monitoring devices.

or

**L O C A L / R E M O T E M O D E
R E M O T E**

This mode should be selected when an ISN or RCC control is to be used to control the chiller. This mode will allow the ISN to control the following items:

- Remote Start/Stop
- Cooling Setpoint
- Load Limit
- History Buffer Request

If the unit receives no valid ISN transmission for 5 minutes, it will revert back to the locally programmed values.

Option 6 – Unit Control Mode

**C O N T R O L M O D E
R E T U R N L I Q U I D**

Unit control is based on return chilled liquid temperature. Return Chilled Liquid Control can only be selected on units that have 4 to 6 compressors (dual system units).

or

**C O N T R O L M O D E
L E A V I N G L I Q U I D**

Option 7 – Display Units

**D I S P L A Y U N I T S
I M P E R I A L**

This mode displays system operating values in Imperial units of °F or PSIG.

or

**D I S P L A Y U N I T S
S I**

This mode displays system operating values in Scientific International Units of °C or barg.

**Option 8 – Lead/Lag Type
(two system units only)**

**L E A D / L A G C O N T R O L
M A N U A L S Y S 1 L E A D**

SYS 1 selected as lead compressor. SYS 1 lead option **must** be chosen if Hot Gas Bypass is installed.

or

**L E A D / L A G C O N T R O L
M A N U A L S Y S 2 L E A D**

SYS 2 selected as lead compressor.

or

**L E A D / L A G C O N T R O L
A U T O M A T I C**

Lead/Lag between systems may be selected to help equalize average run hours between systems on chillers with 2 refrigerant systems. Auto lead/lag allows automatic lead/lag of the two systems based on an average run hours of the compressors in each system. A new

lead/lag assignment is made whenever all compressors shut down. The microprocessor will then assign the “lead” to the system with the shortest average run time.

Option 9 – Condenser Fan Control Mode

F A N C O N T R O L
D I S C H A R G E P R E S S U R E

Condenser fans are controlled by discharge pressure only. This mode must be chosen.

or

F A N C O N T R O L
A M B I E N T & D S C H P R E S S

Do not select this option on R-410A chillers.

Option 10 – Manual Override Mode

M A N U A L O V E R R I D E M O D E
D I S A B L E D

This option allows overriding of the daily schedule that is programmed. MANUAL OVERRIDE MODE – DISABLED indicates that override mode has no effect.

or

M A N U A L O V E R R I D E M O D E
E N A B L E D

Manual Override Mode is enabled. This is a service function and when enabled, will allow the unit to start when shut down on the daily schedule. It will automatically be disabled after 30 minutes.

Option 11 – Current Feedback Options Installed:

C U R R E N T F E E D B A C K
N O N E

This mode should be selected when the panel is not equipped with current sensing capability.

or

C U R R E N T F E E D B A C K
O N E P E R U N I T

This mode should be selected when an optional 2ACE Module is installed to allow combined current monitoring of all systems by sensing current on the incoming line.

or

C U R R E N T F E E D B A C K
O N E P E R S Y S T E M

This mode should be selected when an optional 2ACE module is installed to allow individual current monitoring of each system. SYS 1 input is to J7 of the I/O. SYS 2 input is to J8 of the I/O.

Option 12 – Power Fail Restart

P O W E R F A I L R E S T A R T
A U T O M A T I C

Chiller auto restarts after a power failure.

P O W E R F A I L R E S T A R T
M A N U A L

After a power failure, the Unit Switch must be toggled before restart at the unit is allowed. NORMALLY MANUAL RESTART should NOT BE SELECTED.

Option 13 – Soft Start Enable/Disable

S O F T S T A R T
D I S A B L E D

SOFT START “DISABLED” **must** be selected on all chillers.

This message may not be viewable on non-European chillers.

Option 14 – Unit Type

U N I T T Y P E
L I Q U I D C H I L L E R

The UNIT TYPE message cannot be modified under the unit keys.



“LIQUID CHILLER” must be displayed, or damage to compressors or other components will occur if operated in the HEAT PUMP or CONDENSING UNIT modes.

If unit type needs to be changed to make the unit a liquid chiller, remove power and then remove the jumper on J11-12. Reapply power to the micropanel and the microprocessor will store the change.

Option 15 – Refrigerant Type

REFRIGERANT TYPE
R - 410 A

Refrigerant type R-410A must be selected under Service Mode. Refrigerant type is displayed under the OPTIONS key, but is only programmable in Service Mode.



Incorrect programming may cause damage to compressors.

Option 16 – Expansion Valve Type

EXPANSION VALVE TYPE
THERMOSTATIC

Expansion valve type, thermostatic or electronic may be selected under Service Mode. Expansion valve type is displayed under the OPTIONS key, but is only programmable in Service Mode. YCAL 0019 through YCAL 0066 chillers will typically always be equipped with thermostatic expansion valves.



Incorrect programming may cause damage to compressors.

Also see the Unit Keys Programming Quick Reference List in Table 16.

Option 17 – Flash Card Update

FLASH CARD UPDATE
DISABLED

A Flash Card is used to input the operating program into the chiller IPU. A Flash Card is used instead of an EPROM. Normally, a Flash Card update is not required and the message above will be displayed.

If the operating software is to be updated, insert the Flash Card into the Flash Card input port. Turn off the Unit Switch and set the FLASH CARD UPDATE TO “ENABLED” using the ↑ and ↓ keys.

FLASH CARD UPDATE
ENABLED

Press the ENTER key and the following message will be displayed until the update has been completed. The keypad and display will not respond during the update. DO NOT reset or power down the chiller until the update is completed.

FLASH CARD UPDATING
PLEASE WAIT . . .

After the update is completed, an automatic reboot will occur. If an error occurred, the following message will appear with the error code and no reboot will occur:

FLASH CARD UPDATE
ERROR XXXXXX

If the update resulted in an error, the original program will still be active. When an error occurs, assure the correct Flash Card was utilized. Incorrect chiller software will cause an error. If this is not the case, the Flash Card is most likely defective or the IPU and I/O combo board is bad.

Option 18 – Remote Temperature Reset

REMOTE TEMP RESET
INPUT XXXXXXXXXXXXXXXX

REMOTE TEMP RESET INPUT selection is programmable according to the type of input utilized. The following options are available:

- DISABLED (default)
- 0.0 – 10.0VDC
- 2.0 – 10.0VDC
- 0.0 – 20.0mA
- 4.0 – 20.0mA

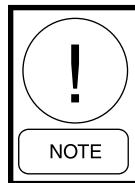

The options display message for Remote Temperature Reset Input only appears if the Temperature Reset Option is enabled under Service Mode.

Option 19 – Pump Control

Pump Control is utilized to operate the optional on-board pump kit or to control an external pump through dry contacts 23 and 24. To use this option, the following selection should be made in the Service Mode:



When YORK HYDRO KIT PUMPS = 1, the controls will be closed to run the pumps whenever any one of the following conditions are true:

- Low Leaving Chilled Liquid Fault
- Any compressor is running
- Daily Schedule is ON and Remote Stop is closed.

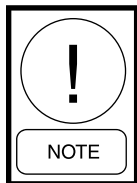

Even if one of the above conditions are true, the pump will not run if the chiller has been powered up for less than 30 seconds; or if the pump has run in the last 30 seconds to prevent pump overheating.



EXTERNAL EVAP PUMP should be selected if an external pump is being controlled with the chiller pump contacts. The operation will be the same as YORK HDRO KIT PUMPS = 1

The following option should not be selected.



Option 20 – Pump Selection

The displays for this PUMP SELECTION option should only appear if “YORK HYDRO KIT PUMPS = 2” are selected under Option 19. Presently, this option should not be used.

CLOCK

The CLOCK display shows the current day, time, and date. Pressing the CLOCK key will show the current day, time, and date.

It is important that the date and time be correct, otherwise the daily schedule will not function as desired if programmed. In addition, for ease of troubleshooting via the History printouts, the day, time, and date should be correct.

To change the day, time, and date press the CLOCK key. The display will show something similar to the following:



The line under the F is the cursor. If the day is correct, press the ENTER/ADV key. The cursor will move under the 0 in 08 hours. If the day is incorrect, press the ↑ (UP) or ↓ (DOWN) arrow keys until the desired day is displayed and then press the ENTER/ADV key at which time the day will be accepted and the cursor will move under the first digit of the “2 digit hour”. In a similar manner, the hour, minute, meridian, month, day, and year may be programmed, whenever the cursor is under the first letter/numeral of the item. Press the ↑ (UP) or ↓ (DOWN) arrow keys until the desired hour, minute, meridian; day, month, and year are displayed. Pressing the ENTER/ADV key will save the valve and move the cursor on to the next programmable variable.

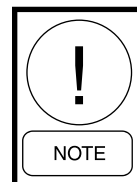

Jumper J11 on the microboard must be set to the “CLKON” position to turn on the clock. If this is not done, the clock will not function.

TABLE 16 - UNIT KEYS OPTIONS PROGRAMMING QUICK REFERENCE LIST

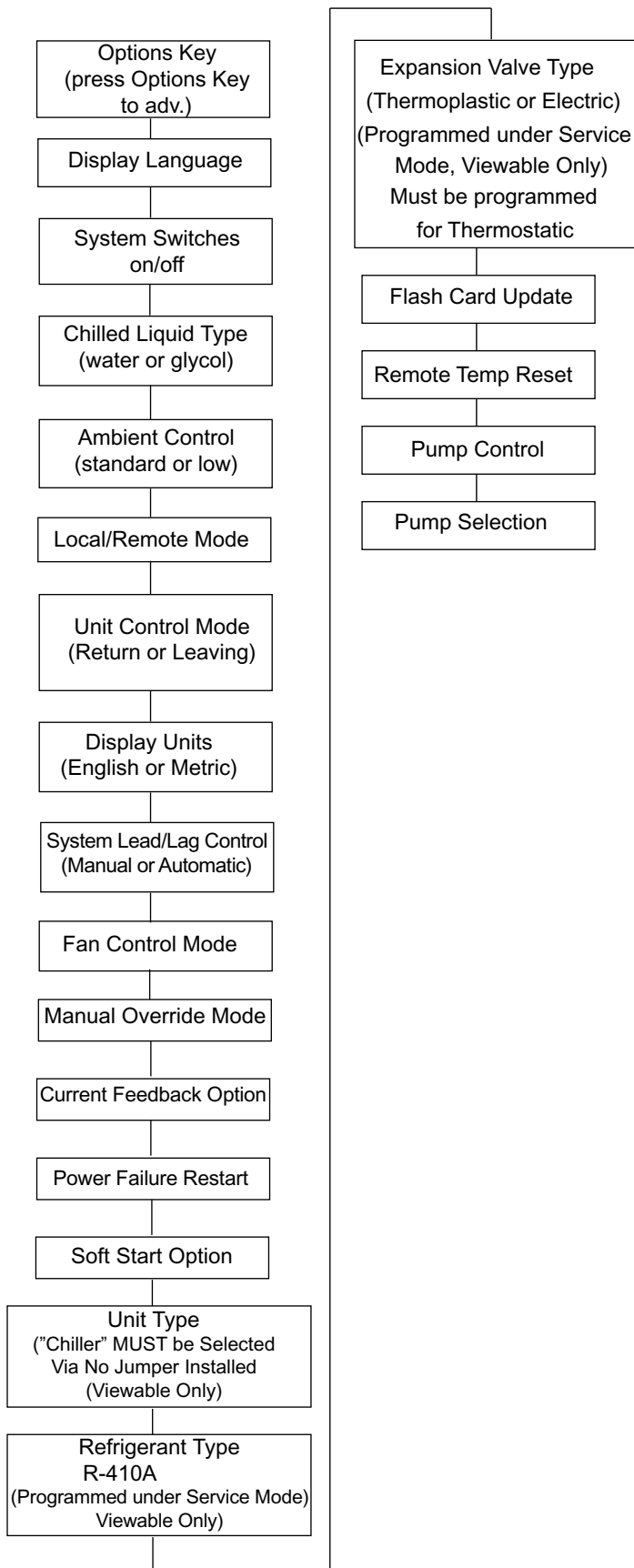

Table 16 provides a quick reference list for the Unit key setpoints.

LD07405d

SECTION 8 – UNIT OPERATION

CAPACITY CONTROL

To initiate the start sequence of the chiller, all run permissive inputs must be satisfied (flow/remote start/stop switch), and no chiller or system faults exist.

The first phase of the start sequence is initiated by the Daily Schedule Start or any Remote Cycling Device. If the unit is shut down on the daily schedule, the chilled water pump microboard contacts (TB8-6 and 7) will close to start the pump when the daily schedule start time has been reached. Once flow has been established and the flow switch closes, capacity control functions are initiated, if the remote cycling contacts wired in series with the flow switch are closed.

It should be noted that the chilled water pump contacts (TB8-6 and 7) are not required to be used to cycle the chilled water pump. However, in all cases the flow switch must be closed to allow unit operation.

The control system will evaluate the need for cooling by comparing the actual leaving or return chilled liquid temperature to the desired setpoint, and regulate the leaving or return chilled liquid temperature to meet that desired setpoint.

SUCTION PRESSURE LIMIT CONTROLS

The anticipatory controls are intended to prevent the unit from ever actually reaching a low-pressure cutout. Loading is prevented, if the suction pressure drops below 1.15 times suction pressure cutout (15% below the cutout). Loading may reoccur after suction pressure rises above the unload point and a period of one minute elapses. This control is only operable if the optional suction pressure transducers are installed.

DISCHARGE PRESSURE LIMIT CONTROLS

The discharge pressure limit controls unload a system before it reaches a safety limit due to high load or dirty condenser coils. The microprocessor monitors discharge pressure and unloads a system, if fully loaded, by one compressor when discharge pressure exceeds the programmed cutout minus 10 PSIG (0.69 barg). Reloading will occur when the discharge pressure on the affected system drops to 85% of the unload pressure and 10 minutes have elapsed.

This control is only applicable if optional discharge pressure transducers are installed.

LEAVING CHILLED LIQUID CONTROL

The setpoint, when programmed for Leaving Chilled Liquid Control, is the temperature the unit will control to within plus or minus the (control) cooling range. The Setpoint High Limit is the Setpoint plus the Cooling Range. The Setpoint Low Limit is the Setpoint minus the Cooling Range. Figure 41 should be utilized to aid in understanding the following description of Leaving Chilled Liquid Control.

If the leaving chilled liquid temperature is above the Setpoint High Limit, the lead compressor on the lead system will be energized along with the liquid line solenoid. Upon energizing any compressor, the 60 second Anti-Coincidence timer will be initiated to prevent multiple compressors from turning ON.

If after 60 seconds of run-time the leaving chilled liquid temperature is still above the Setpoint High Limit, the next compressor in sequence will be energized. Additional compressors will be energized at a rate of once every 60 seconds if the chilled liquid temperature remains above the Setpoint High Limit and the chilled liquid temperature is dropping less than 3 °F per minute. The lag system will not be allowed to start a compressor until the lead system has run for 5 minutes.

If the chilled liquid temperature falls below the Setpoint High Limit but is greater than the Setpoint Low Limit, loading and unloading do not occur. This area of control is called the control range.

If the chilled liquid temperature drops to between Setpoint Low Limit and 0.5 °F (0.28 °C) below the Setpoint Low Limit, unloading (a compressor turns OFF) occurs at a rate of 1 every 30 seconds. If the chilled liquid temperature falls to a value greater than 0.5 °F (0.28 °C) below the Setpoint Low Limit but not greater than 1.5 °F (0.83 °C) below the Setpoint Low Limit, unloading occurs at a rate of 20 seconds. If the chilled liquid temperature falls to a value greater than 1.5 °F (0.83 °C) below the Setpoint Low Limit, unloading occurs at a rate of 10 seconds. If the chilled liquid temperature falls below 1 °F above the low chilled liquid temperature cutout, unloading occurs at a rate of 10 seconds if it is greater than 10 seconds.

In water cooling mode on R-410A chillers, the minimum low limit of the control range will be 40.0 °F. For leaving chilled liquid temperature setpoint and control range combinations that result in the low limit of the

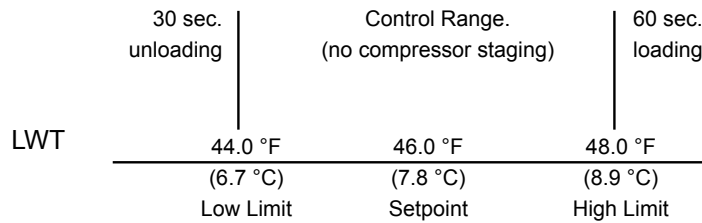

Leaving Water Temperature Control – Compressor Staging
Setpoint = 46.0 °F (7.8 °C) Range = plus or minus 2 °F (1.1 °C)

FIGURE 41 - LEAVING WATER TEMPERATURE CONTROL EXAMPLE

control range being below 40.0°F, the low limit will be reset to 40.0°F and the difference will be added to the high limit. This will result in a control range the same size as programmed but not allow the unit to run below 40.0°F. This control will not affect glycol chillers.

Hot gas, if present, will be the final step of capacity. Hot gas is energized when only a single compressor is running and LWT is less than SP. Hot gas is turned OFF as temperature rises when LWT is more than SP plus CR/2. If temperature remains below the setpoint low limit on the lowest step of capacity, the microprocessor will close the liquid line solenoid, after turning off hot gas, and pump the system down before turning off the last compressor in a system.

The leaving chilled liquid setpoint is programmable from 40 °F to 70 °F (4.4 °C to 21.1 °C) in water chilling mode and from 10 °F to 70 °F (-12.2 °C to 21.1 °C) in glycol chilling mode. In both modes, the cooling range can be from plus or minus 1.5 °F to plus or minus 2.5 °F (plus or minus 0.83 °C to 1.39 °C) leaving chilled liquid control.

LEAVING CHILLED LIQUID CONTROL OVERRIDE TO REDUCE CYCLING

To avoid compressor cycling the microprocessor will adjust the setpoint upward temporarily. The last run time of the system will be saved. If the last run time was greater than 5 minutes, no action is to be taken. If the last run time for the lead system was less than 5 minutes, the microprocessor will increase the setpoint high limit according to the chart at right, with a maximum value allowed of 50 °F (See Figure 42).

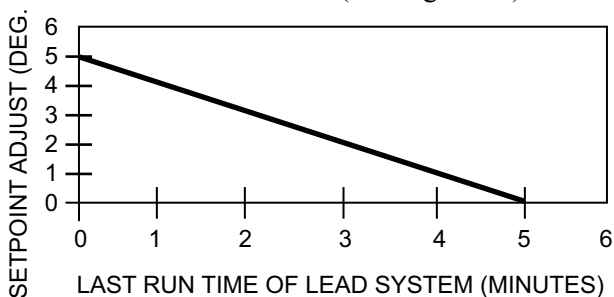

FIGURE 42 - SETPOINT ADJUST

If adding the setpoint adjust value to the setpoint high limit causes the setpoint high limit to be greater than 50 °F, the setpoint high limit will be set to 50 °F, and the difference will be added to the setpoint low limit.

Once a system runs for greater than 5 minutes, the setpoint adjust will be set back to 0. This will occur while the system is still running.

LEAVING CHILLED LIQUID SYSTEM LEAD/LAG AND COMPRESSOR SEQUENCING

A Lead/Lag option may be selected to help equalize average run hours between systems with 2 refrigerant systems. This may be programmed under the OPTIONS key. Auto Lead/Lag allows automatic Lead/Lag of the two systems based on average run hours of the compressors in each system. Manual Lead/Lag selects specifically the sequence which the microprocessor starts systems.

On a hot water start, once a system starts, it will turn on all compressors before the next system starts a compressor. The microprocessor will sequence compressors within each circuit to maximize individual compressor run time on individual compressors within a system to prevent short cycling.

Each compressor in a system will be assigned an arbitrary priority number 1, 2, or 1, 2, 3. The non-running compressor within a system with the lowest priority number will always be the next compressor to start. The running compressor with priority number 1 will always be the next to shut off. Whenever a compressor is shut off, the priority numbers of all compressors will be decreased by 1 with wrap-around. This control scheme assures the same compressor does not repeatedly cycle ON and OFF.

Once the second system starts a compressor on a 2 system chillers, the microprocessor will attempt to equally load each system as long as the system is not limiting or pumping down. Once this occurs, loading and unloading will alternate between systems, loading the lead system first or unloading the lag system first.

RETURN CHILLED LIQUID CONTROL
(Can be used on Dual System 4, 5 and 6 compressor Units Only)

Return chilled liquid control is based on staging the compressors to match the cooling load. The chiller will be fully loaded when the return water temperature is equal to the Cooling Setpoint plus the Range. The chiller will be totally unloaded (all compressors OFF) when the return water temperature is equal to the Cooling Setpoint (See sample in Table 17). At return water temperatures between the Cooling Setpoint and Cooling Setpoint plus Range, compressor loading and unloading will be determined by the formulas in Table 18.

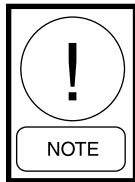

Return Chilled Liquid Control MUST only be used when constant chilled liquid flow is ensured.

The range MUST always be programmed to equal the temperature drop across the evaporator when the chiller is “fully loaded”. Otherwise, chilled liquid temperature will over or under shoot. Variable flow must never be used in return chilled liquid mode.

Normal loading will occur at intervals of 60 seconds according to the temperatures determined by the formulas. Unloading will occur at a rate of 30 seconds according to the temperatures determined in the formulas used to calculate the on and off points for each step of capacity.

The return chilled liquid setpoint is programmable from 40 °F to 70 °F (4.4 °C to 21.1 °C) in water chilling mode and from 10 °F to 70 °F (-12.2 °C to 21.1 °C) in glycol chilling mode. In both modes, the cooling range can be from 4 °F to 20 °F (2.2° to 11.1 °C).

As an example of compressor staging (refer to Table 17), a chiller with six compressors using a Cooling Setpoint programmed for 45 °F (7.20 °C) and a Range Setpoint of 10 °F (5.56 °C). Using the formulas in Table 18, the

control range will be split up into six (seven including hot gas) segments, with the Control Range determining the separation between segments. Note also that the Cooling Setpoint is the point at which all compressors are OFF, and Cooling Setpoint plus Range is the point all compressors are ON. Specifically, if the return water temperature is 55 °F (12.8 °C), then all compressors will be ON, providing full capacity. At nominal gpm, this would provide approximately 45 °F (7.2 °C) leaving water temperature out of the evaporator.

If the return water temperature drops to 53.4 °F (11.9 °C), one compressor would cycle OFF leaving five compressors running. The compressors would continue to cycle OFF approximately every 1.7 °F (.94 °C), with the exception of hot gas bypass. Notice that the hot gas bypass would cycle ON when the return water temperature dropped to 46.25 °F (7.9 °C). At this point one compressor would be running with hot gas.

Should the return water temperature rise from this point to 46.7 °F (8.2 °C), the hot gas bypass would shut OFF, still leaving one compressor running. As the load increased, the compressors would stage on every 1.7 °F (.94 °C).

Also note that Table 18 not only provides the formulas for the loading (ON POINT) and unloading (OFF POINT) of the system, the “STEP” is also shown in the tables. The “STEP” is the increment in the sequence of the capacity control scheme that can be viewed under the OPER DATA key. Please refer to the section on the DISPLAY/PRINT keys for specific information on the OPER DATA key.

RETURN CHILLED LIQUID SYSTEM LEAD/LAG AND COMPRESSOR SEQUENCING

A lead/Lag option may be selected to help equalize average run hours between systems with 2 refrigerant systems. This may be programmed under the OPTIONS key. Auto Lead/Lag of the 2 systems based on average run hours of the compressors in each system. Manual Lead/Lag selects specifically the sequence which the microprocessor starts the systems.

TABLE 17 - SAMPLE COMPRESSOR STAGING FOR RETURN WATER CONTROL

COMPRESSOR STAGING FOR RETURN WATER CONTROL						
4 COMPRESSOR						
COOLING SETPOINT = 45 °F (7.2 °C) RANGE = 10 °F(5.6 °C)						
# OF COMP ON	0	* 1+HG	1	2	3	4
RWT	45 °F (7.2 °C)	46.25 °F (7.9 °C)	47.5 °F (8.6 °C)	50.0 °F (10.0 °C)	52.5 °F (11.4 °C)	55.0 °F (12.8 °C)

*Unloading only

TABLE 18 - RETURN CHILLED LIQUID CONTROL FOR 4 COMPRESSORS (6 STEPS)

*STEP	COMPRESSOR	COMPRESSOR ON POINT	COMPRESSOR OFF POINT
0	0	SETPOINT	SETPOINT
1	1 W/HGB	SP + CR/8 (NOTE 1)	SETPOINT
2	1 NO HGB	SP + CR/4	SP + CR/8
3	2	SP + 2*CR/4 (NOTE 2)	SP + CR/4
4	2	SP + 2*CR/4	SP + CR/4 (NOTE 3)
5	3	SP + 3*CR/4	SP + 2*CR/4
6	4	SP + CR	SP + 3*CR/4

Notes:

1. Step 1 is Hot Gas Bypass and is skipped when loading occurs. Hot Gas Bypass operation is inhibited during pumpdown.
2. Step 3 is skipped when loading occurs.
3. Step 4 is skipped when unloading occurs.

* STEP can be viewed using the OPER DATA key and scrolling to COOLING DEMAND.

The microprocessor will sequence compressors load and unload systems according to Table 19. The microprocessor will lead/lag compressors within each circuit to maximize individual compressor run time for the purpose of lubrication. It will also prevent the same compressor from starting 2 times in a row. The microprocessor will not attempt to equalize run time on individual compressors within a system.

Each compressor in a system will be assigned an arbitrary number 1, or 2. The non-running compressor within a system with the lowest priority number will always be the next compressor to start. The running compressor with priority number 1 will always be the next compressor to shut off. Whenever a compressor is shut off, the priority numbers of all compressors in each system will be decreased by 1 with the wrap around. This control scheme assures the same compressor does not repeatedly cycle ON and OFF.

ANTI-RECYCLE TIMER

The programmable anti-recycle timer assures that systems do not cycle. This timer is programmable under the PROGRAM key between 300 and 600 seconds. Whenever possible, to reduce cycling and motor heating, the anti-recycle timer should be adjusted to 600 seconds. The programmable anti-recycle timer starts the timer when the first compressor in a system starts. The timer begins to count down. If all of the compressors in a circuit cycle OFF, a compressor within the circuit will not be permitted to start until the anti-recycle timer has timed out. If the lead system has run for less than 5 minutes, 3 times in a row, the anti-recycle timer will be extended to 10 minutes.

ANTI-COINCIDENCE TIMER

This timer is not present on single-system units. Two timing controls are present in software to assure compressors within a circuit or between systems, do not

TABLE 19 - RETURN CHILLED LIQUID CONTROL FOR 4 COMPRESSORS (6 STEPS)

STEP	LEAD SYSTEM				LAG SYSTEM		
	COMP 1	COMP 2	-		COMP 1	COMP 2	-
0	OFF	OFF	-		OFF	OFF	-
1	ON + HG	OFF	-	SEE NOTE 1	OFF	OFF	-
2	ON	OFF	-		OFF	OFF	-
3	ON	OFF	-	SEE NOTE 2	ON	OFF	-
4	ON	ON	-	SEE NOTE 3	OFF	OFF	-
5	ON	ON	-		ON	OFF	-
6	ON	ON	-		ON	ON	-

NOTES

1. Step is Hot Gas Bypass and is skipped when loading occurs. Hot Gas Bypass operation is inhibited during pumpdown. For Leaving Chilled Liquid Control the Hot Gas Bypass solenoid is energized only when the lead compressor is running and the LWT less than SP, the Hot Gas Bypass solenoid is turned OFF when the LWT more than SP plus CR/2.
2. Step 3 is skipped when loading occurs.
3. Step 4 is skipped when unloading occurs.

start simultaneously. The anti-coincidence timer assures there is at least a one minute delay between system starts on 2-circuit systems. This timer is NOT programmable. The load timers further assure that there is a minimum time between compressor starts within a system.

EVAPORATOR PUMP CONTROL AND YORK HYDRO KIT PUMP CONTROL

The evaporator pump dry contacts (CTB2 – terminals 23 and 24) are energized when any of the following conditions are true:

1. Low Leaving Chilled Liquid Fault.
2. Any compressor is running.
3. Daily Schedule is ON, Unit Switch is ON and Remote Stop is closed.

The pump will not run if the micro panel has been powered up for less than 30 seconds or if the pump has run in the last 30 seconds to prevent pump motor overheating.

Whenever the option “YORK HYDRO KIT PUMPS = 1” is selected under the OPTIONS key, the pump control will be as described above. DO NOT SELECT the option “YORK HYDRO KIT PUMPS = 2” under the OPTIONS key. If a dual pump option is installed, the active pump is selected by the selector switch.

EVAPORATOR HEATER CONTROL

The evaporator heater is controlled by ambient air temperature. When the ambient temperature drops below 40 °F (4.4 °C) the heater is turned ON. When the temperature rises above 45 °F (7.2 °C) the heater is turned OFF. An under voltage condition will keep the heater OFF until full voltage is restored to the system.

PUMPDOWN CONTROL

Each system has a pump-down feature upon shut-off. Manual pumpdown from the keypad is not possible. On a non-safety, non-unit switch shutdown, all compressors but one in the system will be shut OFF. The LLSV will also be turned OFF. The final compressor will be allowed to run until the suction pressure falls below the cutout, or for 180 seconds, whichever comes first.

STANDARD CONDENSER FAN CONTROL

Condenser fan operation must be programmed with the OPTIONS key under “Fan Control.” Condenser fan control can be selected for Ambient Temperature and Discharge Pressure, or Discharge Pressure only.

The condenser fan control by “Ambient Temperature and Discharge Pressure” is a feature that is integral to the standard software control. If the optional discharge transducer is not installed, the condenser fans will operate based on outdoor ambient temperature only. Refer to the following pages for model specific details.

The condenser fan control by “Discharge Pressure” is a feature that can be selected if the discharge pressure transducer is installed and fan cycling is not a concern. Fan control by discharge pressure will work according to the tables on the following pages. The fan control on-pressure and fan differential off-pressure are programmable under the PROGRAM key.

The delay between turning ON and OFF fan stages is always fixed at 5 seconds.

When a fan stage is turned ON by pressure, the on pressure for the next stage is increased 20 PSIG and ramped back to the programmed on pressure over the next 20 seconds. Typically, standard ambient control on pressure should be programmed at 385 PSIG with a differential of 125 PSIG.

When a fan stage is turned OFF (programmed on pressure minus programmed differential), the off pressure for the next stage is decreased 20 PSIG and ramped back to the programmed off pressure minus the differential over the next 20 seconds.



A low ambient kit MUST be installed when “AMBIENT CONTROL LOW AMBIENT” is selected under the OPTIONS key.



Compressor damage could occur if programming does not match installed hardware.

Detailed Standard Fan Control operation is shown in Table 20 and 21.

YCAL0043 – 0066 LOW AMBIENT FAN CONTROL OPTION

General

The low ambient option consists of a VFD (Variable Frequency Drive) for each system that controls the speed of the first fan (Fan 1, Sys #1 or Fan 2, Sys # 2) in the fan staging sequence. The VFD's are located in an enclosure in the compressor/piping/heat exchanger section on (2) compressor chillers. System # 1 VFD is located on the bottom and System # 2 is on the top. Single system chillers have the VFD installed on the top of chiller above the compressor section. Examples of the typical VFD location and enclosure mountings are shown in Figures 54 and 55.

The VFD will control fan speed when only a single fan is running on a system. As discharge pressure rises, the fan speed will be increased from zero RPM to full speed. As discharge pressure continues to rise, the VFD will operate the fan at full speed and the second fan will be brought ON in a system, if needed. Whenever the second fan is brought ON, the inverter will already be running the first fan at full speed.

If discharge pressure falls, the chiller microprocessor will turn the second fan OFF by de-energizing the fan contactor. If pressure continues to fall, VFD speed will decrease in an effort to maintain discharge pressure. Speed may drop to the point where the VFD turns the fan completely OFF or virtually OFF with a continued drop in pressure.

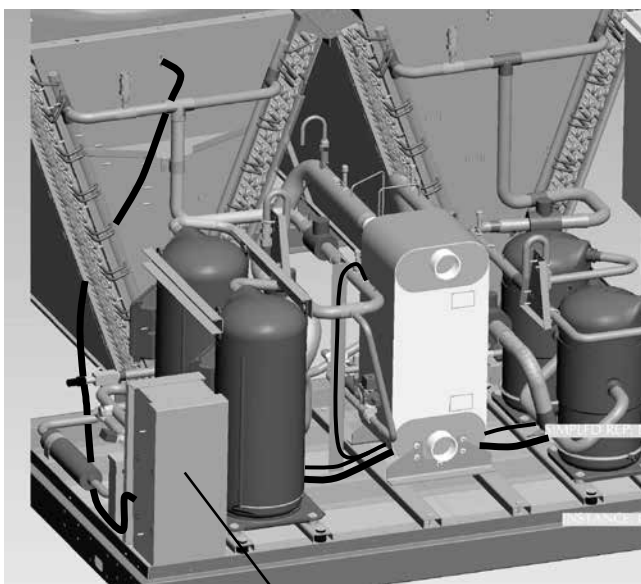

LD11298

Dual System VFD Enclosure Location

The VFD control input signal is from the discharge pressure transducer in the respective system. The transducer signal feeds both the chiller microprocessor board input and the VFD.

The VFD will control the fan speed not only in low ambient conditions, but in all ambients based on discharge pressure. Speed control of the respective system will occur whenever high voltage power is applied to the VFD power inputs through the 7M (Sys 1) or 10M (Sys 2) contactors. The chiller microprocessor will energize the 7M and 10M contactors whenever the respective system liquid line solenoid is energized.

The VFD controls the speed of the fan based on a discharge pressure setpoint and a differential control range. When a compressor starts in a system, the inverter is activated through the 7M (Sys 1) or 10 M (Sys 2) contactor, which is controlled from the respective liquid line solenoid valve control signal. At discharge pressures below 260 PSIG, the VFD will turn the fan OFF or speed will be reduced to small movements in fan rotation.

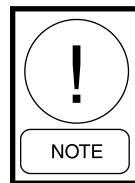

The pressures indicated in this section describing the VFD control will vary from VFD to VFD. Expect tolerances for the entire pressure range of control to potentially shift -0 PSIG/+24 PSIG.

The VFD will ramp up the speed of the fan as pressure rises above the low end of the speed control range. Throughout the pressure control range, the VFD controls the speed of the fan based on discharge pressure in the range of approximately 260 to 292 PSIG. At pressures above 260 PSIG, the VFD will run the system fan at full speed.

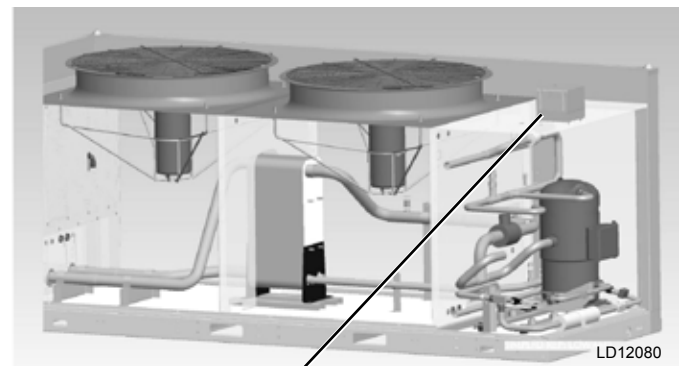

LD12080

Single System VFD Enclosure Location

FIGURE 54 - TYPICAL VFD ENCLOSURE LOCATIONS

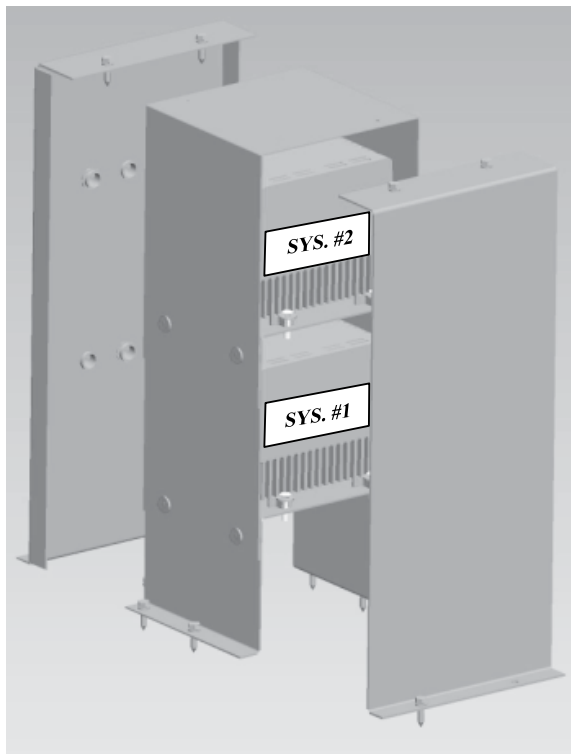

Dual System VFD Enclosure

LD11299a

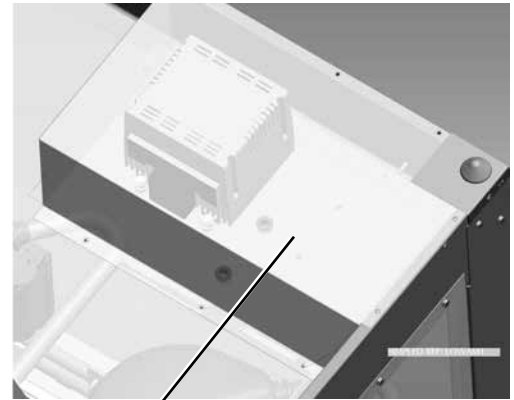

Single System VFD Enclosure

LD12081

FIGURE 55 - TYPICAL VFD ENCLOSURE CONFIGURATIONS

As pressure drops below 292 PSIG, the VFD will slow the speed of the fan to try to maintain discharge pressure within the control range. The VFD will try to maintain pressure in the range of 260 to 292 PSIG by raising and lowering the speed of the fan. If pressure drops below 260 PSIG, the VFD will virtually turn the system fan completely OFF. Some slight fan movement or very slow rotation may be noted, although the fan may appear to stop completely.

CONFIGURATION (JUMPERS AND POTENTIOMETERS)

Each VFD is pre-configured at the factory prior to shipping and should be ready for operation when it arrives onsite. A quick check of the settings is recommended. The jumpers must be in the positions shown in Table 27.

TABLE 27 - VFD JUMPERS

JUMPER	60 HZ	50 HZ
J2	REMOVE	—
J3	IN	—
J4	REMOVE	—
J5	IN	—
J6	IN	—
J7	IN	—
J8	IN	—
J9	IN	REMOVE

Potentiometer settings are also preset at the factory. The potentiometers should be in the positions shown in Figure 57. The pots do not have numerical settings and are set according to the arrow positions indicated. DO NOT change the potentiometer settings unless they do not match the positioning of the potentiometers shown in Figure 57. The position of the potentiometers are as follows:

- P1 should be full CW (260 PSIG)
- P2 should be full CCW (32 PSIG).

Modifying these settings may cause damage to the chiller or control problems.

The P1 pot sets the setpoint which is the top end of the control range. This setting is the discharge pressure at which the fan will be operating at full speed. The P2 pot sets the range. This is the range of pressure where the VSD modulates the fan speed from 0 RPM to full speed. The range is subtracted from the setpoint to calculate the 0 RPM pressure.

Wiring

VFD wiring is simple and requires only 3-phase power in, 3-phase power out, and a 2-wire signal from the transducer. No start, stop, or other alternate power re-

quirements are needed to run the VFD. Figure's 56 and 57 show the power and control wiring schematically as well as the actual connections. The VFD controlled fan will operate whenever the liquid line solenoid on the respective system is energized.

PROGRAMMING

Condenser fan control type must be programmed under both the OPTIONS and PROGRAM keys when a VFD is installed on the chiller. Under the OPTIONS key, FAN CONTROL must be programmed for DISCHARGE PRESSURE CONTROL only. This will assure condenser fan control of the chiller is solely by discharge pressure, with no ambient control.

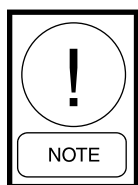

Under the PROGRAM key, the FAN CONTROL ON PRESSURE should be programmed for 425 PSIG and the FAN DIFFERENTIAL OFF PRESSURE must be programmed for 125 PSIG.

Programming as suggested assures the chiller control points for the second fan in the fan staging sequence and the inverter control points are matched for opti-

imum control of the fans at reduced ambient temperatures. When the chiller and VFD fan control points are programmed properly, the fans will operate as outlined in Table 28.

POTENTIOMETER SETTINGS	
P1	P2
292 PSI	32 PSI

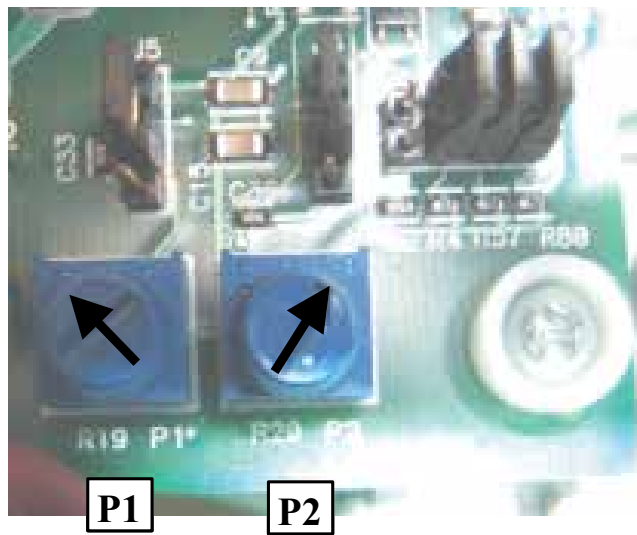

LD11300a

FIGURE 57 - POTENTIOMETER SETTINGS

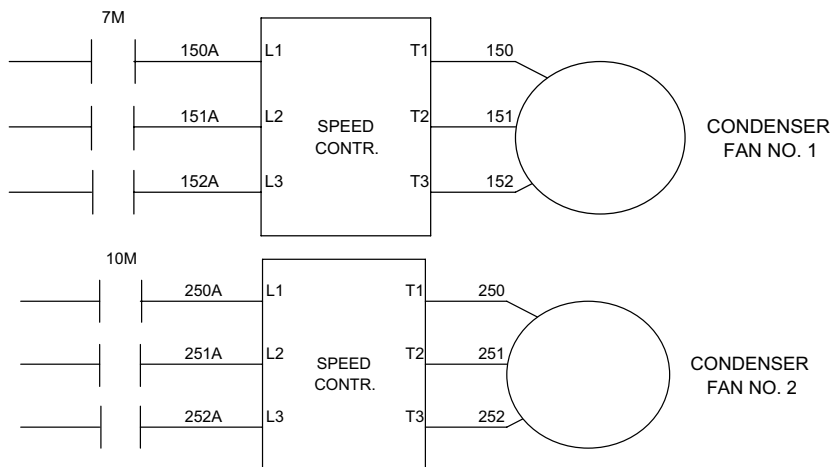

LD11301

FIGURE 56 - INVERTER POWER WIRING SC

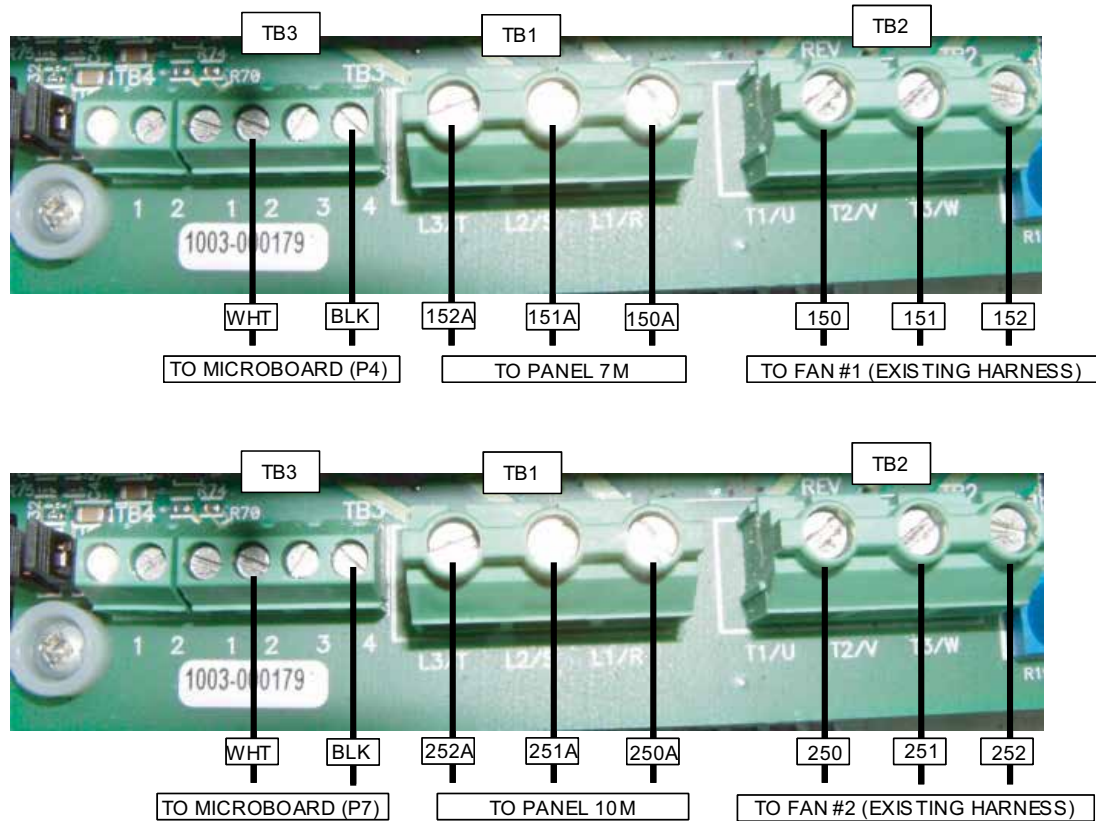

FIGURE 58 - INVERTER WIRING

LD11302

TABLE 28 - YCAL0043-0066 VFD LOW AMBIENT OPTION – CONDENSER FAN CONTROL OPERATION

FAN STAGE	ON	OFF	CONTACTOR		MICROBOARD		FAN #	
			SYS 1	SYS 2	SYS 1	SYS 2	SYS 1	SYS 2
1: VFD CONTROL (1 FAN VARIABLE SPEED)	FAN SPEED IS A FUNCTION OF DISCHARGE PRESSURE. WHEN THE LIQUID LINE SOLENOID IS ENERGIZED, SPEED INCREASES WITH PRESSURE	FAN WILL TURN OFF OR TURN VERY SLOWLY WHEN PRESSURE DROPS BELOW 260 PSIG.	7M	10M	TB7-3	TB10-9	1	2
2: 1 FAN VFD CONTROL 2ND FAN FULL SPEED UNDER CONTACTOR CONTROL	425 PSIG, BOTH FANS WILL BE RUNNING FULL SPEED	DISCHARGE PRESSURE < 260 PSIG (PRESSURE IS < FAN CONTROL ON PRESSURE OF 425 PSIG MINUS FAN DIFFERENTIAL PRESSURE OF 125 PSIG = 300 PSIG)	7M & 8M	10M & 11M	TB7-3 AND TB7-10	TB10-9 AND TB10-10	1 & 3	2 & 4

8

LOAD LIMITING

Load Limiting is a feature that prevents the unit from loading beyond the desired value. Two and Four compressor units can be load limited to 50%. This would allow only 1 compressor per system to run. Three and six compressor units can be load limited to 33% or 66%. The 66% limit would allow up to 2 compressors per system to run, and the 33% limit would allow only 1 compressor per system to run. Five compressor units may be load limited to 40% (1 compressor per system runs) or 80% (up to 2 compressors per system) are permitted to run. No other values of limiting are available.

There are two ways to load limit the unit. The first is through remote communication via an ISN. Load limit stages are sent through YORK Talk on pages 9 and 10 of feature 54. Page 9 is stage 1 load limit and page 10 is stage 2 load limit.

A second method of load limiting the unit is through closing dry contacts connected to the Load Limit (CTB1 – Terminals 13 to 21). Load limiting involves closing the Load Limit input with a dry contact. Load limiting is either 80%, 66% or 50%, depending on the number of compressors on the unit. Table 29 shows the load limiting permitted for the various number of compressors. Only Stage 1 is available utilizing a dry contact.

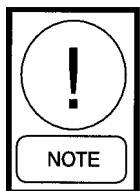

Simultaneous operation of Remote Load Limiting and EMS-PWM Temperature Reset (described on following pages) cannot occur.

TABLE 29 - COMPRESSOR OPERATION –LOAD LIMITING

COMPRESSORS IN UNIT	STAGE 1	STAGE 2
2	50%	-
3	66%	33%
4	50%	-
5	80%	40%
6	66%	33%

COMPRESSOR RUN STATUS

Compressor run status is indicated by closure of contacts at CTB2 – terminals 25 to 26 for system 1 and CTB2 – terminals 27 to 28 for system 2.

ALARM STATUS

System or unit shutdown is indicated by normally open alarm contacts opening whenever the unit shuts down on a unit fault, locks out on a system fault, or experiences a loss of power to the chiller electronics. System 1 alarm contacts are located at CTB2 – terminals 29 to 30. System 2 alarm contacts are located at CTB2 – terminals 31 to 32. The alarm contacts will close when conditions allow the unit to operate, or the fault is reset during a loss of power, the contacts will remain open until power is reapplied and no fault conditions exist.

BAS/EMS TEMPERATURE RESET USING A VOLTAGE OR CURRENT SIGNAL

The Remote Reset Option allows the Control Center of the unit to reset the chilled liquid setpoint using a 0 to 10VDC input, or a 4 to 20mA input connected to CTB1 terminals A- and A+. Whenever a reset is called for, the change may be noted by pressing the Cooling Setpoints key twice. The new value will be displayed as “REM SETP = XXX °F.”

If a 0 to 10VDC signal is supplied, it is applied to terminals A+ and A-, and jumper JP1 on the I/O board must be inserted between pins 2 and 3. To calculate the reset chilled liquid setpoint for values between 0VDC and 10VDC use the following formula:

$$\text{Setpoint} = \text{Local Chilled Liquid Setpoint} + \text{°Reset}$$

$$\text{°Reset} = \frac{(\text{DC voltage signal}) \times (\text{*Max Reset Value})}{10}$$

Example:
 Local Chilled Liquid Setpoint = 45 °F (7.22 °C)
 *Max Reset Value = 20 °F (11.11 °C)
 Input Signal = 6VDC

(English)

$$\text{°Reset} = \frac{6\text{VDC} \times 20 \text{ °F}}{10} = 12 \text{ °F Reset}$$

$$\text{New Setpoint} = 45 \text{ °F} + 12 \text{ °F} = 57 \text{ °F}$$

(Metric)

$$\text{°Reset} = \frac{6\text{VDC} \times 11.11 \text{ °C}}{10} = 6.67 \text{ °C Reset}$$

$$\text{New Setpoint} = 7.22 \text{ °C} + 6.67 \text{ °C} = 13.89 \text{ °C}$$

* Max Reset Value is the “Max EMS-PWM Remote Temperature Reset” setpoint value described in the programming section under Cooling Setpoints. Programmable values are from 2 °F to 40 °F (1.11 °C to 11.11 °C).

If a **4-20mA signal is supplied**, it is applied to terminals A+ and A- and **jumper JP1 on the I/O board must be installed between pin 1 and 2**. To calculate the chilled liquid setpoint for values between 4mA and 20 mA use the following formula:

Setpoint = Local Chilled Liquid Setpoint + °Reset

$$^{\circ}\text{Reset} = \frac{(\text{mA signal} - 4) \times (*\text{Max Reset Value})}{16}$$

Example:

Local Chilled Liquid Setpoint = 45° (7.22 °C)

*Max Reset Value = 10 °F (5.56 °C)

Input Signal = 12 mA

(English)

$$^{\circ}\text{Reset} = \frac{8\text{mA} \times 10^{\circ}\text{F}}{16} = 5^{\circ}\text{F Reset}$$

$$\text{Setpoint} = 45^{\circ}\text{F} + 5^{\circ}\text{F} = 50^{\circ}\text{F}$$

(Metric)

$$^{\circ}\text{Reset} = \frac{8\text{mA} \times 5.56^{\circ}\text{C}}{16} = 2.78^{\circ}\text{C Reset}$$

$$\text{Setpoint} = 7.22^{\circ}\text{C} + 2.78^{\circ}\text{C} = 10.0^{\circ}\text{C}$$

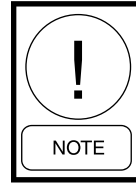

A 240-24 Volt Ratio Transformer (T3) is used to derive nominal 12 volt output from the 120 volt supply.

THIS PAGE INTENTIONALLY LEFT BLANK

SECTION 9 – SERVICE AND TROUBLESHOOTING

CLEARING HISTORY BUFFERS

The history buffers may be cleared by pressing the HISTORY key and then repeatedly pressing the UP arrow key until you scroll past the last history buffer choice. The following message will be displayed:

```
INITIALIZE HISTORY
ENTER = YES
```

Pressing the ENTER/ADV key at this display will cause the history buffers to be cleared. Pressing any other key will cancel the operation.

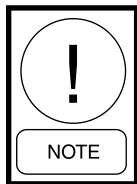

DO NOT CLEAR BUFFERS. Important information may be lost. Contact factory service.

SERVICE MODE

Service Mode is a mode that allows the user to enable or disable all of the outputs (except compressors) on the unit, change chiller configuration setup parameters and view all the inputs to the microboard.

To enter Service Mode, turn the Unit Switch OFF and press the following keys in the sequence shown; PROGRAM, UP ARROW, UP ARROW, DOWN ARROW, DOWN ARROW, ENTER. Service Mode will time out after 30 minutes and return to normal control mode, if the panel is accidentally left in this mode. Otherwise, turning the Unit Switch ON will take the panel out of Service Mode.

SERVICE MODE – OUTPUTS

After pressing the key sequence as described, the control will enter Service Mode permitting the outputs (except compressors), operating hours, refrigerant type, expansion valve type, and start/hour counters to be viewed and or modified. The ENTER/ADV key is used to advance through the outputs. Using the ↑ and ↓ (UP/DOWN) arrow keys will turn the respective digital output ON/OFF or modify the value.

Following is the order of outputs that will appear as the ENTER/ADV key is pressed:

```
SYS 1 COMP 1 STATUS TB7-2 IS:
  SYS 1 LLSV STATUS TB7-3 IS:
  SYS 1 COMP 2 STATUS TB7-4 IS:
  SYS 1 COMP 3 STATUS TB7-5 IS:
```

```
SYS 1 HGBP STATUS TB7-7 IS:
SYS 2 COMP 1 STATUS TB10-2 IS:
  SYS 2 LLSV STATUS TB10-3 IS:
  SYS 2 COMP 2 STATUS TB10-4 IS:
  SYS 2 COMP 3 STATUS TB10-5 IS:
  SYS 1 FAN OUTPUT 1 TB7-8 IS:
  SYS 1 FAN OUTPUT 2 TB7-9 IS:
  SYS 1 FAN OUTPUT 3 TB7-10 IS:
  SYS 2 FAN OUTPUT 1 TB10-8 IS:
  SYS 2 FAN OUTPUT 2 TB10-9 IS:
  SYS 2 FAN OUTPUT 3 TB10-10 IS:
  EVAP HEATER STATUS TB8-2 IS:
  SYS 1 ALARM STATUS TB8-3 IS:
  SYS 2 ALARM STATUS TB9-2 IS:
  EVAP PUMP STATUS TB8-6,7 IS:
  SYS 2 HGBV STATUS TB10-7 IS:
```

```
  SPARE DO TB8-4 IS:
```

```
  SPARE DO TB8-5 IS:
```

```
  SPARE DO TB8-8, 9 IS:
```

```
  SPARE DO TB9-4 IS:
```

```
  SYS 1 EEV OUTPUT TB5-1, 2 = XXX%
```

```
  SYS 2 EEV OUTPUT TB6-1, 2 = XXX%
```

```
  SYS 1 COND FAN SPEED J15-1,5 = XXX%
```

```
  SYS 2 COND FAN SPEED J15-2,6 = XXX%
```

```
  SPARE AO J15-3,7 = XXX%
```

```
  SPARE AO J15-4,8 = XXX%
```

```
  DATA LOGGING MODE 1 = ON, 0 = OFF
```

```
  DATA LOGGING TIMER X SECS
```

```
  SOFT START (disabled)
```

```
  REFRIGERANT TYPE (R410A only)
```

```
  EXPANSION VALVE TYPE (Thermostatic Only)
```

```
  REMOTE TEMP RESET OPTION =
```

```
  REMOTE INPUT SERVICE TIME =
```

```
“NORTH AMERICAN FEATURE SET ENABLED”
```

```
  HYDRO PUMP SELECTION
```

```
  EVAP PUMP TOTAL RUN HOURS
```

```
    SYS 1 HOURS
```

```
    SYS 2 HOURS
```

```
    SYS 1 STARTS
```

```
    SYS 2 STARTS
```

Each display will also show the output connection on the microboard for the respective output status shown. For example:

```
SYS 1 LLSV STATUS
TB10 - 3 IS OFF
```

This display indicates that the system 1 liquid line solenoid valve is OFF, and the output connection from the microboard is coming from terminal block 10 – pin 3.

Pressing the ↑ (UP) arrow key will energize the liquid line solenoid valve and OFF will change to ON in the display as the LLSV is energized. Energizing and de-energizing outputs may be useful during troubleshooting.

SERVICE MODE – CHILLER CONFIGURATION

After the Outputs are displayed, the next group of displays relate to chiller configuration and start/hour counters. Data logging, soft start, refrigerant type, pump control selection and expansion valve type all must be programmed to match actual chiller configuration.



Soft start (disabled), Refrigerant Type (R410A), and Expansion Valve Type (Thermostatic), and North American Feature (Enabled) MUST be properly programmed or damage to compressors and other system components may result.

Following is a list of chiller configuration selections, in order of appearance:

- DATA LOGGING MODE = : DO NOT MODIFY
- DATA LOGGING TIMER = : DO NOT MODIFY
- SOFT START
- REFRIGERANT TYPE
- EXPANSION VALVE TYPE
- REMOTE TEMP RESET OPTION
- REMOTE INPUT SERVICE TIME
- FEATURE SET
- PUMP CONTROL SELECTION
- SYS 1 HOURS
- SYS 2 HOURS
- SYS 1 STARTS
- SYS 2 STARTS

The last displays shown on the above list are for the accumulated run and start timers for each system. All values can also be changed using the ↑ (UP) and ↓ (Down) arrow keys, but under normal circumstances would not be required or advised. After the last start display, the microprocessor will display the first programmable value under the PROGRAM key.

SERVICE MODE – ANALOG AND DIGITAL INPUTS

After entering Service Mode (press PROGRAM ↑↑ ↓↓ ENTER), all digital and analog inputs to the microboard can be viewed by pressing the OPER DATA key. After pressing the OPER DATA key, the ↑ (UP) arrow and ↓ (DOWN) arrow keys are used to scroll through the analog and digital inputs.

Following is the order of analog and digital inputs that will appear when sequenced with the ↓ (Down) arrow key:

- (analog inputs)
- SYS 1 SUCT PRESSURE
- UNIT TYPE
- SYS 1 *DISCH PRESSURE
- SYS 1** SUCTION TEMP.
- SYS 2** SUCTION TEMP.
- AMBIENT AIR TEMP.
- LEAVING LIQUID TEMP.
- RETURN LIQUID TEMP.
- SYS 2 SUCTION PRESSURE
- SYS 2 SPARE
- SYS 2 *DISCH PRESSURE
- SYS 1 MTR VOLTS
- SYS 2 MTR VOLTS
- (digital inputs)
- PWM TEMP RESET INPUT
- LOAD LIMIT INPUT
- FLOW SW / REM START
- SPARE
- SINGLE SYSTEM SELECT
- SYS 1 MP / HPCO INPUT
- SYS 2 MP / HPCO INPUT

* The discharge pressure transducer is optional on some models.

** The suction temperature sensor is on EEV units only.

The analog inputs will display the input connection, the temperature or pressure, and corresponding input voltage such as:



This example indicates that the system 1 suction pressure input is connected to plug 7 – pin 10 (J7-10) on the I/O board. It indicates that the voltage is 2.1VDC which corresponds to 81 PSIG (5.6 bars) suction pressure.

The digital inputs will display the input connection and ON/OFF status such as:



This indicates that the flow switch/remote start input is connected to plug 13- pin 5 (J13-5) on the microboard, and is ON (ON = +30VDC unregulated input, OFF = 0VDC input on digital inputs).

CONTROL INPUTS/OUTPUTS

Tables 30 through 33 are a quick reference list providing the connection points and a description of the inputs and outputs respectively. All input and output connections pertain to the connections at the microboard.

TABLE 30 - I/O DIGITAL INPUTS

J13-2	Unit ON/OFF Switch
J13-3	Load Limit Stage 2 on 3, 5 & 6 Comp. Units
J13-4	Load Limit Stage 1
J13-5	Flow Switch and Remote Start/Stop
J13-6	Spare
J13-7	Single System Select (Jumper = Single Sys, No Jumper = Two Sys)
J13-8	CR1 (Sys 1 Motor Protector/High Pressure Cutout)
J13-10	CR2 (Sys 2 Motor Protector/High Pressure Cutout)

TABLE 31 - I/O DIGITAL OUTPUTS

TB7-2	SYS 1 Compressor 1
TB7-3	SYS 1 Liquid Line Solenoid Valve
TB7-4	SYS 1 Compressor 2
TB7-5	SYS 1 Compressor 3
TB7-7	SYS 1 Hot Gas Bypass Valve
TB10-2	SYS 2 Compressor 1

TABLE 31 - I/O DIGITAL OUTPUTS (CONT'D)

TB10-3	SYS 2 Liquid Line Solenoid Valve
TB10-4	SYS 2 Compressor 2
TB10-5	SYS 2 Compressor 3
TB7-8	SYS 1 Condenser Fan Output 1
TB7-9	SYS 1 Condenser Fan Output 2
TB7-10	SYS 1 Condenser Fan Output 3
TB10-8	SYS 2 Condenser Fan Output 1
TB10-9	SYS 2 Condenser Fan Output 2
TB10-10	SYS 2 Condenser Fan Output 3
TB8-2	Evaporator Heater
TB8-3	SYS 1 Alarm
TB9-2	SYS 2 Alarm
TB8-6 & 7	Evaporator Pump Starter
TB10-7	SYS 2 Hot Gas Bypass Valve

TABLE 32 - I/O ANALOG INPUTS

J7-10	SYS 1 Suction Transducer -or- SYS 1 Low Pressure Switch
J11-12	Unit Type: Chiller = NO Jumper J11-12 to +24 VDC YCUL Condensing Unit = Jumper J11-12 to +24 VDC (Do NOT Use)
J7-11	SYS 1 Discharge Pressure Transducer (Optional)
J6-9	Ambient Air Temperature Sensor
J6-7	Leaving Chilled Liquid Temperature Sensor
J6-8	Return Chilled Liquid Temperature Sensor
J9-10	SYS 2 Suction Pressure Transducer -or- SYS 2 Low Pressure Switch
J9-11	SYS 2 Discharge Pressure Transducer (Optional)
J7-12	Unit/SYS 1 Voltage
J9-12	SYS 2 Voltage
J11-11	Remote Temperature Reset

TABLE 33 - I/O ANALOG OUTPUTS

N/A	Not Applicable
------------	----------------

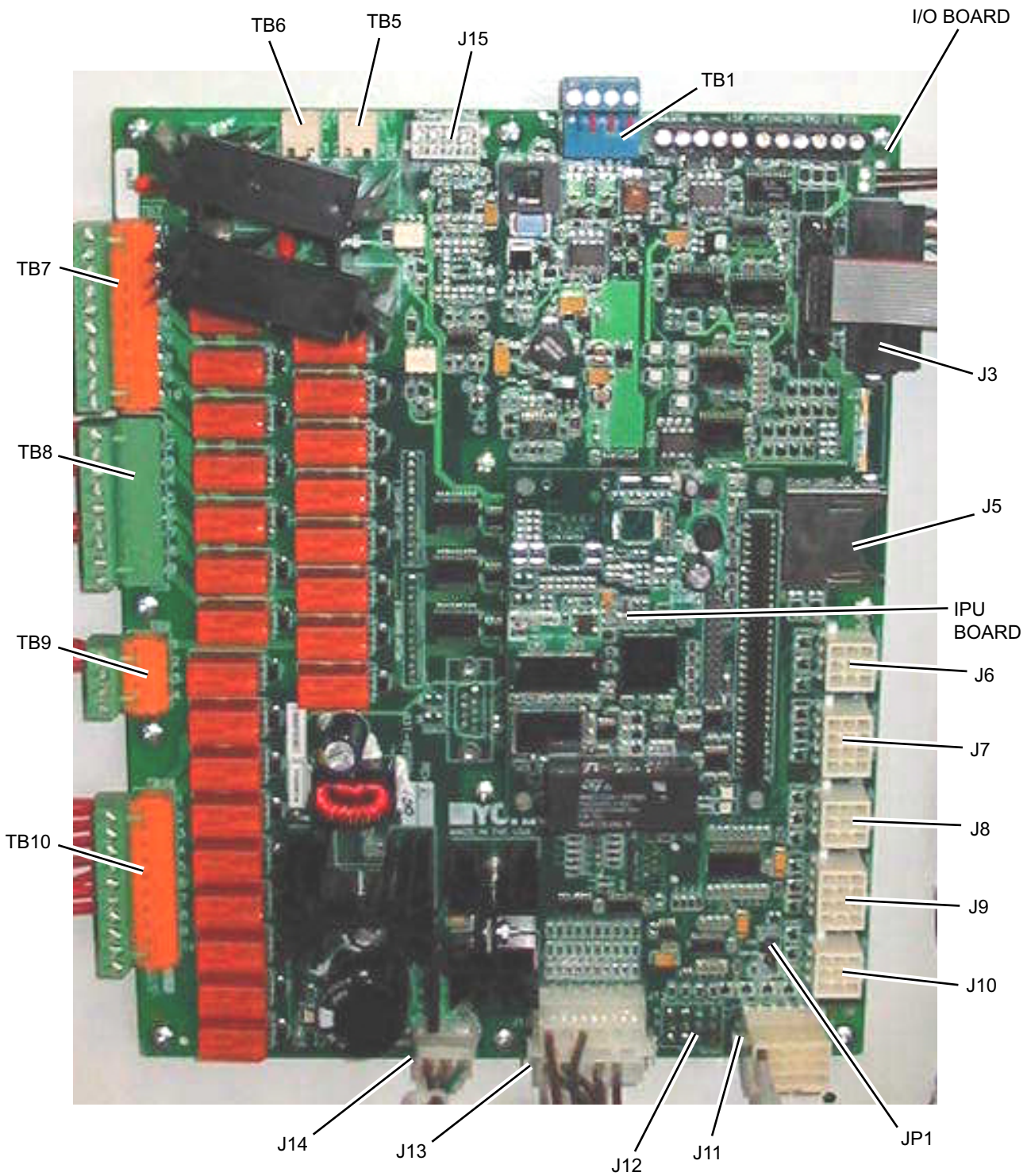

LD12721

FIGURE 59 - MICROBOARD LAYOUT

CHECKING INPUTS AND OUTPUTS

Digital Inputs

Refer to the unit wiring diagram. All digital inputs are connected to J13-1 of the I/O board. The term “digital” refers to two states – either ON or OFF. As an example, when the flow switch is closed, 30VDC will be applied to J13, pin 5 (J13-5) of the I/O board. If the flow switch is open, 0VDC will then be present at J13-5.

Pin 1 of J13 is an *unregulated 30VDC source* used to supply the DC voltage to the various user contacts, unit switch, flow switch, etc. This DC source is factory wired to CTB1, terminal 13. Any switch or contact used as a digital input would be connected to this terminal, with the other end connecting to its respective digital input on the microboard. Any time a switch or contact is closed, 30VDC would be applied to that particular digital input. Any time a switch or contact is open, 0VDC would be applied to that particular digital input.

Typically, voltages of 24 to 36VDC could be measured for the DC voltage on the digital inputs. This voltage is in reference to ground. The unit case should be sufficient as a reference point when measuring digital input voltages.

Analog Inputs – Temperature

Refer to the unit wiring diagram. Temperature inputs are connected to the microboard on plug J6. These analog inputs represent varying DC signals corresponding to varying temperatures. All voltages are in reference to the unit case (ground). Following are the connections for the temperature sensing inputs:

Outside Air Sensor

J6-6 = +5VDC regulated supply to sensor.

J6-9 = VDC input signal to the microboard.

See Table 34 for voltage readings that correspond to specific outdoor temperatures.

J6-3 = drain (shield connection = 0VDC) Return

**TABLE 34 - OUTDOOR AIR SENSOR
TEMPERATURE/VOLTAGE /
CORRELATION**

TEMP °F	VOLTAGE (SIGNAL INPUT TO RETURN)	TEMP °C
0	0.7	-18
5	0.8	-15
10	0.9	-12
15	1.0	-9
20	1.1	-7
25	1.2	-4
30	1.4	-1
35	1.5	2
40	1.7	4
45	1.8	7
50	2.0	10
55	2.2	13
60	2.3	16
65	2.5	18
70	2.6	21
75	2.8	24
80	2.9	27
85	3.1	29
90	3.2	32
95	3.4	35
100	3.5	38
105	3.6	41
110	3.7	43
115	3.8	46
120	3.9	49
125	4.0	52
130	4.1	54

TABLE 35 - ENTERING/LEAVING CHILLED LIQUID TEMPERATURE SENSOR

TEMP °F	VOLTAGE (SIGNAL INPUT TO RETURN)	TEMP °C
10	1.33	-12
12	1.39	-11
14	1.46	-10
16	1.51	-9
18	1.58	-8
20	1.65	-7
22	1.71	-6
24	1.78	-4
26	1.85	-3
28	1.91	-2
30	1.98	-1
32	2.05	0
34	2.12	1
36	2.19	2
38	2.26	3
40	2.33	4
42	2.40	6
44	2.47	7
46	2.53	8
48	2.60	9
50	2.65	10
52	2.73	11
54	2.80	12
56	2.86	13
58	2.92	14
60	2.98	16
62	3.05	17
64	3.11	18
66	3.17	19
68	3.23	20
70	3.29	21
72	3.34	22
74	3.39	23
76	3.45	24
78	3.5	26
80	3.54	27

Liquid and Refrigerant Sensor Test Points (Table 35)

Entering Chilled Liquid Sensor

J6-5 = +5VDC regulated supply to sensor.

J6-8 = VDC input signal to the I/O board. See Table 35 for voltage readings that correspond to specific liquid temperatures.

J6-2 = Drain (shield connection = 0VDC) Return.

Leaving Chilled Liquid Temperature Sensor

J6-4 = +5VDC regulated supply to sensor.

J6-7 = VDC input signal to the microboard. See Table 35 for voltage readings that correspond to specific liquid temperatures.

J6-1 = drain (shield connection = 0VDC) Return.

Analog Inputs – Pressure

Refer to the unit wiring diagram. Pressure inputs are connected to the microboard on plugs J7 and J9. These analog inputs represent varying DC signals corresponding to varying pressures. All voltages are in reference to the unit case (ground).

System 1 discharge and suction pressures will be connected to J7 of the microboard. System 2 discharge and suction pressure transducers will be connected to J9 of the microboard.

The discharge transducers are optional on all units. If the discharge transducers are not installed, no connections are made to the microboard and the discharge pressure readout on the display would be zero.

The suction pressure transducers are standard on all YCAL's. The suction pressure transducers have a range of 0 to 400 PSIG. The output will be linear from 0.5VDC to 4.5VDC over the 400 PSIG (27.5 barg) range.

The discharge transducers have a range from 0 to 650 PSIG. The output will be linear from 0.5VDC to 4.5VDC over the 600 PSIG (41.25 barg) range. Following is the formula that can be used to verify the voltage output of the transducer. All voltage reading are in reference to ground (unit case).

$$V = (\text{Pressure in PSIG} \times .01) + .5$$

or

$$V = (\text{Pressure in BARG} \times .145) + .5$$

where V = DC voltage output
Pressure = pressure sensed by transducer

The I/O board connections for the Discharge Transducers are as follows.

System 1 Discharge Transducer

- J7-6 = +5VDC regulated supply to transducer.
- J7-11 = VDC input signal to the microboard. See the formula above for voltage readings that correspond to specific discharge pressures.
- J7-7 = +5VDC return.
- J7-2 = Drain (shield connection = 0VDC).

System 2 Discharge Transducer

- J9-6 = +5VDC regulated supply to transducer.
- J9-11 = VDC input signal to the microboard. See the formula above for voltage readings that correspond to specific discharge pressures.
- J9-7 = +5VDC return.
- J9-2 = Drain (shield connection = 0VDC).

TABLE 36 - PRESSURE TRANSDUCERS

0-400 PSIG SUCTION PRESSURE TRANSDUCER		0-600 PSIG DISCHARGE PRESSURE TRANSDUCER	
PRESSURE PSIG	VOLTAGE VDC	PRESSURE PSIG	VOLTAGE VDC
0	0.5	0	0.5
50	1.0	75	1.0
100	1.5	150	1.5
150	2.0	225	2.0
200	2.5	300	2.5
250	3.0	375	3.0
300	3.5	450	3.5
350	4.0	525	4.0
400	4.5	600	4.5

RED WIRE = 5V, BLACK WIRE = 0V, WHITE/GREEN WIRE = SIGNAL

TEST POINTS:

Suction Pressure:

- System 1:Microboard J7-10 to J7-9
- System 2:Microboard J9-10 to J9-9

Discharge Pressure:

- System 1:Microboard J7-11 to J7-7
- System 2:Microboard J9-11 to J9-7

The suction transducers have a range from 0 to 400 PSIG (27.5 barg). The output will be linear from 0.5VDC to 4.5VDC over the 400 PSIG (27.5 barg) range. Following is a formula that can be used to verify the voltage output of the transducer. All voltage readings are in reference to ground (unit case).

$$V = (\text{Pressure in PSIG} \times .02) + .5$$

or

$$V = (\text{Pressure in barg} \times .29) + .5$$

where V = DC voltage input to microprocessor
Pressure = pressure sensed by transducer

Following are the I/O board connections for the Suction Transducer.

System 1 Suction Transducer

J7-5 = +5VDC regulated supply to transducer.

J7-10 = VDC input signal to the microboard.

See the formula above for voltage readings that correspond to specific suction pressures.

J7-9 = +5VDC return.

J7-1 = Drain (shield connection = 0VDC).

System 2 Suction Transducer

J9-5 = +5VDC regulated supply to transducer.

J9-10 = VDC input signal to the microboard.

See the formula above for voltage readings that correspond to specific suction pressures.

J7-9 = +5VDC return.

J7-11 = Drain (shield connection = 0VDC).

Digital Outputs

Refer to the unit wiring diagram and Figure 60. The digital outputs are located on TB7, TB8, and TB9 and TB-10 of the microboard. ALL OUTPUTS ARE 120VAC with the exception of TB8-6 to TB8-7 which are the contacts that can be used for a remote evaporator

tor pump start signal. The voltage applied to either of these terminals would be determined by field wiring.

Each output is controlled by the microprocessor by switching 120VAC to the respective output connection energizing contactors, evaporator heater, and solenoids according to the operating sequence (see Figure 60).

The I/O board is supplied with 120VAC via connections at TB7-1, TB7-6, TB10-1, TB10-6, TB8-1 and TB9-1. Figure 60 illustrates the relay contact architecture on the microboard.

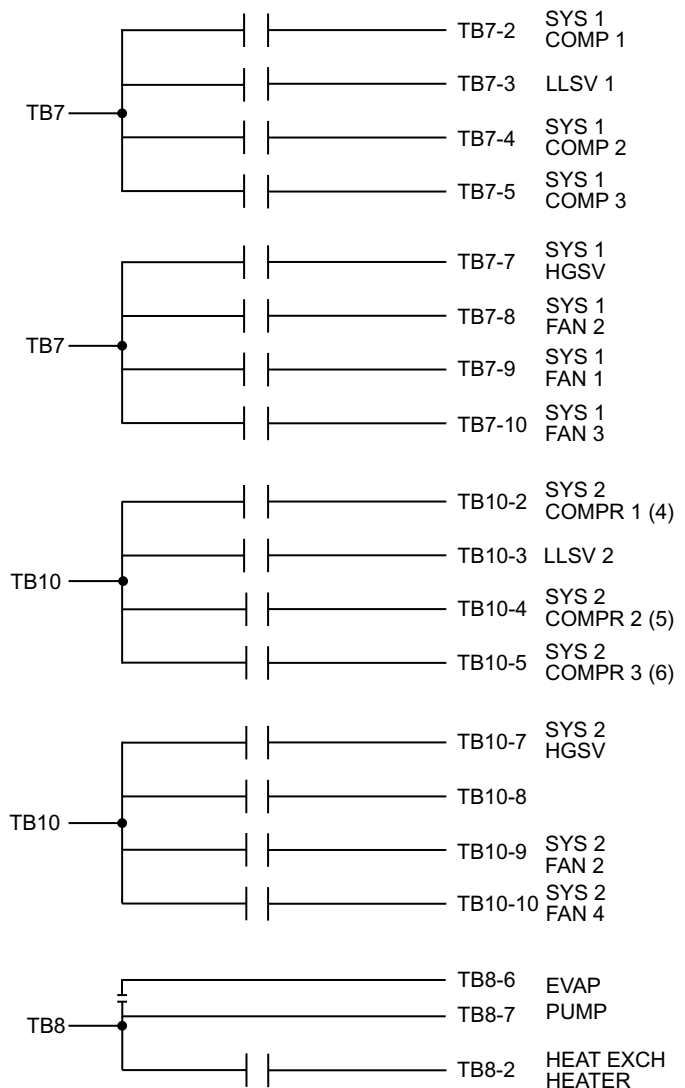

LD12722

FIGURE 60 - I/O BOARD RELAY CONTACT ARCHITECTURE

OPTIONAL PRINTER INSTALLATION

The micro panel is capable of supplying a printout of chiller conditions or fault shutdown information at any given time. This allows operator and service personnel to obtain data and system status with the touch of the keypad. In addition to manual print selection, the micro panel will provide an automatic printout whenever a fault occurs. Detailed explanation of the print function is given under PRINT key located in the Keypad and Display section.

YORK recommends the field tested WEIGH-TRONIX model 1220 printer (or former IMP 24). This is a compact low cost printer that is ideal for service work and data logging.

The WEIGH-TRONIX printer can be obtained by contacting WEIGH-TRONIX for purchase information at:

WEIGH-TRONIX

2320 Airport Blvd.

Santa Rosa, CA 95402

Phone: 1-800-982-6622 or 1-707-527-5555
(International Orders Only)

The part number for the printer that is packaged specifically for YORK is P/N 950915576. The cable to connect the printer can either be locally assembled from the parts listed, or ordered directly from WEIGH-TRONIX under part number 287-040018.

Parts

The following parts are required:

1. WEIGH-TRONIX model 1220 printer.
2. Wide desk top calculator paper, 2.25" (5.7cm).
3. Twisted Pair Shielded Cable (minimum 3 conductor), #18 AWG stranded, 300V minimum insulation, 25 ft. (7.62m) maximum length.
4. One 25 pin Cannon connector and shell.
Connector: Cannon P/N DB-25P or equivalent.
Shell: Cannon P/N DB-C2-J9.

Assembly and Wiring

All components should be assembled and wired as shown in Figure 61. Strip the outside insulation back several inches and individual wires about 3/8" (9.5 mm) to connect the cable at the Microboard. Do not connect the shield at the printer-end of the cable.

Obtaining a Printout

A printout is obtained by pressing the PRINT key on the keypad and then pressing either the OPER DATA key or HISTORY key.

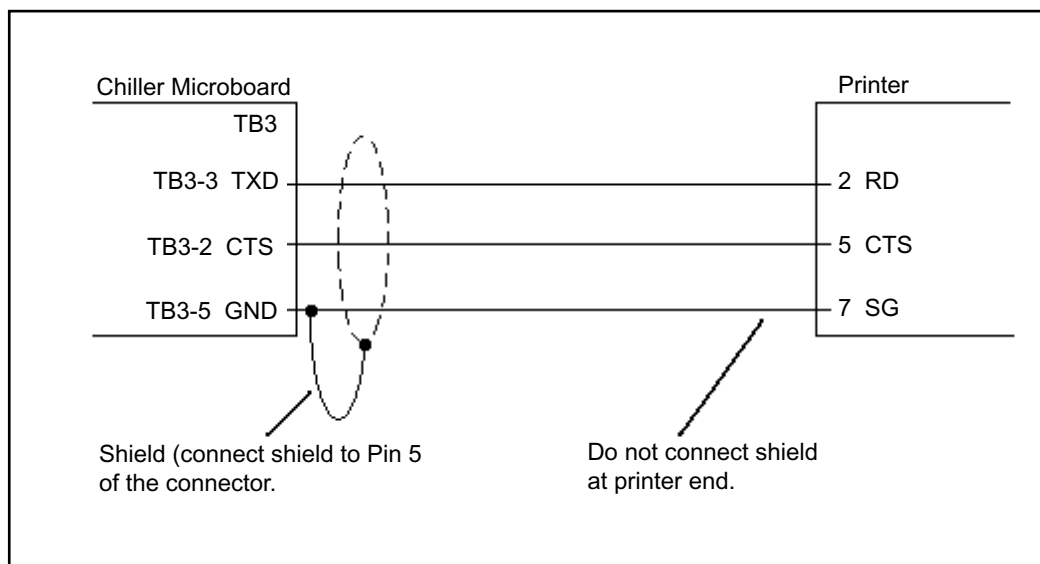

LD12723

FIGURE 61 - PRINTER TO MICROBOARD ELECTRICAL CONNECTIONS

TABLE 37 - TROUBLESHOOTING

PROBLEM	CAUSE	SOLUTION
<p>NO DISPLAY ON PANEL UNIT WILL NOT OPERATE</p>	1. No 115VAC to 24VAC Transformer.	1a. Check wiring and fuse 1FU. 1b. Check wiring emergency stop contacts 5 to L of TB1 terminal block. 1c. Replace Control Transformer.
	2. No 24VAC to Microboard.	2. Check wiring Control Transformer to Microboard.
	3. Control Transformer defective, no 24VAC output.	3. Replace Control Transformer.
	4. Short in wire to temperature sensors or pressure transducers.	4. Unplug connections at IPU II and I/O board to isolate.
	5. Defective IPU & I/O board or the Display board.	5. Replace IPU & I/O board or the Display board.  <p>Contact Johnson Controls Service before replacing circuit boards.</p>
<p>FLOW SWITCH/REM STOP NO RUN PERMISSIVE</p>	1. No chilled liquid flow.	1. Check chilled liquid flow.
	2. Flow switch improperly installed.	2. Check that the flow switch is installed according to manufacturer's instructions.
	3. Defective flow switch.	3. Replace flow switch.
	4. Remote cycling device open.	4. Check cycling devices connected to terminals 13 and 14 of the CTB1 terminal block.
<p>LOW SUCTION PRESSURE FAULT</p>	1. Improper suction pressure cutouts adjustments.	1. Adjust per recommended settings.
	2. Low refrigerant charge.	2. Repair leak if necessary and add refrigerant.
	3. Fouled filter dryer.	3. Change dryer/core.
	4. TXV defective.	4. Replace TXV.
	5. Reduced flow of chilled liquid through the cooler.	5. Check GPM (See Limitations in Installation section). Check operation of pump, clean pump strainer, purge chilled liquid system of air.
	6. Defective suction pressure transducer/ low pressure switch or wiring.	6. Replace transducer/low pressure switch or faulty wiring. Refer to Service section for pressure/ voltage formula.
	7. LLSV defective.	7. Replace LLSV.

TABLE 37 - TROUBLESHOOTING

PROBLEM	CAUSE	SOLUTION
HIGH DISCHARGE PRESSURE FAULT	1. Condenser fans not operating or operating backwards.	1. Check fan motor, fuses and contactors. Assure fan blows air upward.
	2. Too much refrigerant.	2. Remove refrigerant.
	3. Air in refrigerant system.	3. Evacuate and recharge system.
	4. Defective discharge pressure transducer.	4. Replace discharge pressure transducer. Refer to Service section for pressure/voltage formula.
LOW LIQUID TEMP FAULT	1. Improperly adjusted leaving chilled liquid temperature cutout (glycol only).	1. Re-program the leaving chilled liquid temperature cutout.
	2. Micro panel setpoint/range values improperly programmed.	2. Re-adjust setpoint/range.
	3. Chilled liquid flow too low.	3. Increase chilled liquid flow – refer to <i>Limitations in Installation section</i> .
	4. Defective LWT or RWT sensor. (assure the sensor is properly installed in the bottom of the well with a generous amount of heat conductive compound).	4. Compare sensor against a known good temperature sensing device. Refer to Service section for temperature/ voltage table.
MP / HPCO FAULT	1. Compressor internal motor protector (MP) open.	1. Verify refrigerant charge is not low. Verify superheat setting of 10° - 15°F (5.6° - 8.3°C). Verify correct compressor rotation. Verify compressor is not over loaded.
	2. External overload tripped.	2. Determine cause and reset.
	3. HPCO switch open.	3. See High Press. Disch. fault.
	4. Defective HPCO switch.	4. Replace HPCO switch.
	5. Defective CR relay.	5. Replace relay.
COMPRESSOR(S) WON'T START	1. Demand not great enough.	1. No problem. Consult <i>Installation Manual to aid in understanding compressor operation and capacity control</i> .
	2. Defective water temperature sensor.	2. Compare the display with a thermometer. Should be within plus or minus 2 degrees. Refer to Service section for RWT/LWT temperature/voltage table.
	3. Contactor/Overload failure.	3. Replace defective part.
	4. Compressor failure.	4. Diagnose cause of failure and replace.

TROUBLESHOOTING (CONT'D)**TABLE 37 - TROUBLESHOOTING**

PROBLEM	CAUSE	SOLUTION
LACK OF COOLING EFFECT	1. Fouled evaporator surface. Low suction pressure will be observed.	1. Contact the local Johnson Controls Service representative.
	2. Improper flow through the evaporator.	2. Reduce flow to within chiller design specs. See Limitations in Installation section.
	3. Low refrigerant charge. Low suction pressure will be observed.	3. Check subcooling and add charge as needed.

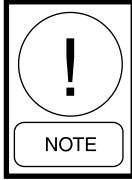
SECTION 10 – MAINTENANCE

It is the responsibility of the equipment owner to provide maintenance on the system.

IMPORTANT

If system failure occurs due to improper maintenance during the warranty period, Johnson Controls will not be liable for costs incurred to return the system to satisfactory operation. The following is intended only as a guide and covers only the chiller unit components. It does not cover other related system components which may or may not be furnished by YORK. System components should be maintained according to the individual manufacturer's recommendations as their operation will affect the operation of the chiller.

COMPRESSORS

Oil Level Check

The oil level can only be tested when the compressor is running in stabilized conditions, to ensure that there is no liquid refrigerant in the lower shell of the compressor. When the compressor is running at stabilized conditions, the oil level must be between 1/4 and 3/4 in the oil sight glass.

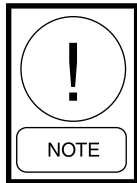

At shutdown, the oil level can fall to the bottom limit of the oil sight glass. Use YORK "V" oil when adding oil.

Oil Analysis

The oil used in these compressors is pale yellow in color (POE oil). If the oil color darkens or exhibits a change in color, this may be an indication of contaminants in the refrigerant system. If this occurs, an oil sample should be taken and analyzed. If contaminants are present, the system must be cleaned to prevent compressor failure.



Never use the scroll compressor to pump the refrigerant system down into a vacuum. Doing so will cause internal arcing of the compressor motor which will result in failure of compressor.

CONDENSER FAN MOTORS

Condenser fan motors are permanently lubricated and require no maintenance.

CONDENSER COILS

Dirt should not be allowed to accumulate on the condenser coil surfaces. Cleaning should be as often as necessary to keep coils clean.

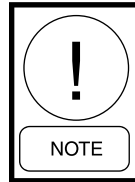

Exercise care when cleaning the coil so that the coil fins are not damaged.

OPERATING PARAMETERS

Regular checks of the system should be performed to ensure that operating temperatures and pressures are within limitations, and that the operating controls are set within proper limits. Refer to the Operation, Start-Up, and Installation sections of this manual.

ON-BOARD BATTERY BACK-UP

The Real Time Clock chip (U5) is located on the 031-02630 IPU II board that maintains the date/time and stores customer programmed setpoints. The Real Time Clock is a 128K bram, P/N 031-02565-000. The IPU II board must have JP1 installed when the 128K bram is installed.

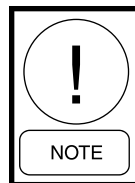

Do not confuse JP1 on the IPU II (031-02630) board with JP1 on the I/O (031-02550) board.

PLATE AND FRAME HEAT EXCHANGER (EVAPORATOR) HEATER

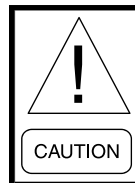

The Plate and Frame Heat Exchanger (evaporator) heater is 120VAC. Disconnecting 120VAC power from the unit, at or below freezing temperatures, can result in damage to the evaporator and unit as a result of the chilled liquid freezing.

OVERALL UNIT INSPECTION

In addition to the checks listed on this page, periodic overall inspections of the unit should be accomplished to ensure proper equipment operation. Items such as loose hardware, component operation, refrigerant leaks, unusual noises, etc. should be investigated and corrected immediately.

BACNET, MODBUS AND YORKTALK 2 COMMUNICATIONS

Data can be read and in some cases modified using a serial communication BACnet, Modbus or YorkTalk 2 network connection. This information allows communications of chiller operating parameters and external control changes to setpoint, load limiting, and start/stop commands.

BACnet and YorkTalk 2 RS485 networks are wired to the + and - terminals of TB1 for port 1 communications. Modbus network connection has the option of RS232 or RS485 connection for port 2 communications. Modbus network is wired to either TB2 or TB3 as follows:

- RS-485: connect to TB2 - Network (-1) to TB2 (-1); Network (+1) to TB2 (+1)
- RS-232: connect to TB3 - Network (RX) to TB3 (TXD); Network (TX) to TB3 (RXD); Network (GND) to TB3 (GND)

Refer to Figure 62 “Micro Panel Connections” for TB1, TB2 and TB3 locations.

In most cases, communication parameters will need to be modified. Table 39 “Values Required for BAS Communication” lists setup parameters for the available protocols. Modification is accomplished by pressing the PROGRAM, DOWN ARROW, DOWN ARROW, DOWN ARROW, DOWN ARROW, and ENTER keys in sequence. The list below shows the displays for the values that may be modified:

DE MODIFIER ADDRESS XXXXX	P2 PROTOCOL XXXXXXXXXX
DE MODIFIER OFFSET XX	P2 MANUAL MAC ADDRESS XXX
P1 PROTOCOL XXXXXX	P2 BAUD RATE XXXXX
P1 MANUAL MAC ADDRESS XXX	P2 PARITY XXXXX
P1 BAUD RATE XXXXX	P2 STOP BITS X
P1 PARITY XXXXX	P2 HW SELECT BIT XXXXX
P1 STOP BITS X	REAL TIME ERROR ## RESET 1 = YES, 0 = NO 0

Note: See Table 29 for error descriptions

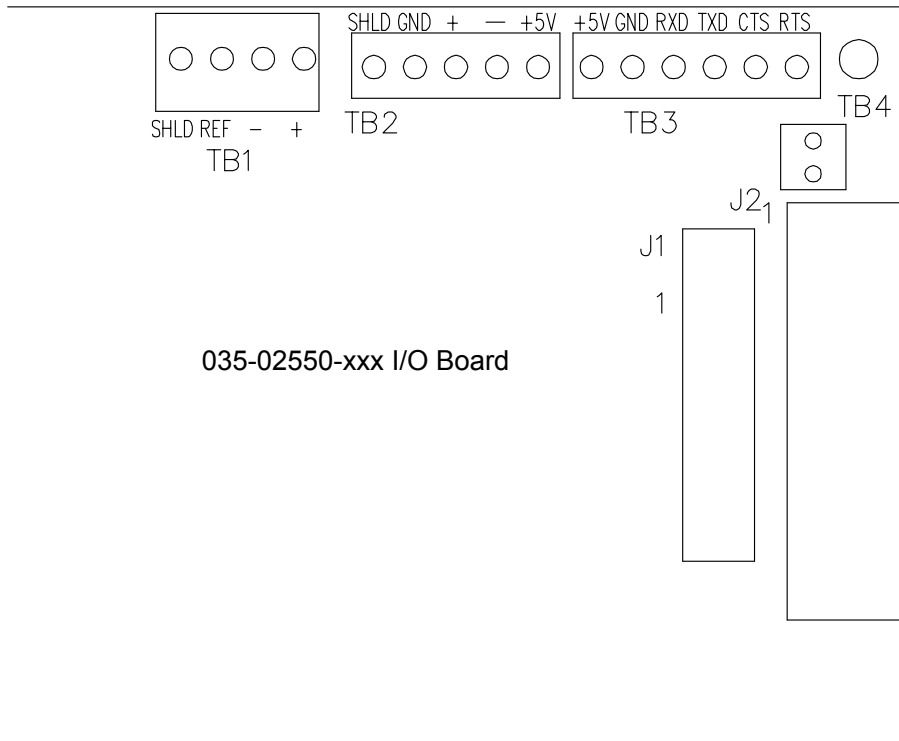

FIGURE 62 - MICRO PANEL CONNECTIONS

The table below shows the minimum, maximum, and default values.

TABLE 38 - MINIMUM, MAXIMUM AND DEFAULT VALUES

DESCRIPTION	MINIMUM	MAXIMUM	DEFAULT
DE MODIFIER ADDRESS	-1	41943	-1
DE MODIFIER OFFSET	-1	99	-1
P1 BAUD RATE	1200	76800	4800
	1200, 4800, 9600, 19200, 38400, 76800, AUTO SELECTABLE		
P2 BAUD RATE	1200	57600	1200
	1200, 4800, 9600, 19200, 38400, 57600 SELECTABLE		
P1, P2 MANUAL MAC ADDRESS	-1	127	-1
P1, P2 PARITY	NONE	IGNORE	NONE
	NONE, EVEN, ODD, IGNORE SELECTABLE		
P1 PROTOCOL	BACNET	API	BACNET
	BACNET, API SELECTABLE		
P2 PROTOCOL	TERMINAL	MODBUS CLIENT	API
	TERMINAL, MODBUS IO, MODBUS SERVER, API, MODBUS CLIENT selectable		
P1, P2 STOP BITS	1	2	1
RESET REAL TIME ERROR	NO	YES	NO

TABLE 39 - VALUES REQUIRED FOR BAS COMMUNICATION

SETTING DESCRIPTION	PROTOCOL		
	BACNET MS/TP	MODBUS RTU ⁵	YORKTALK 2
DE MODIFIER ADDRESS	0 TO 41943 ⁽³⁾	1	-1
DE MODIFIER OFFSET	0 TO 99 ⁽⁴⁾	0	N/A
P1 PROTOCOL	BACNET	N/A	N/A
P1 MANUAL MAC ADDRESS	0-127 ⁽¹⁾	N/A	N/A
P1 BAUD RATE	9600 To 76800 or Auto Selectable ⁽¹⁾	N/A	N/A
P1 PARITY	NONE	N/A	N/A
P1 STOP BITS	1	N/A	N/A
P2 PROTOCOL	N/A	MODBUS SVR	N/A
P2 MANUAL MAC ADDRESS	N/A	2	N/A
P2 BAUD RATE	N/A	9600	N/A
P2 PARITY	N/A	NONE ⁽²⁾	N/A
P2 STOP BITS	N/A	1	N/A
P2 HW SELECT BIT	N/A	RS-485 OR RS-232 ⁽¹⁾	N/A
RESET REAL TIME ERROR	N/A	N/A	N/A
P1 HW SELECT BIT	N/A	N/A	N/A
CHILLER ID	N/A	N/A	0

¹as Required By Network

²or Other As Required By Network

³number Is Multiplied By 100, Set As Required By Network

⁴number Is Added To De Modifier Address, Set As Required By Network

⁵unit Operating Software Version C.Mmc.13.03 Or Later Required For Modbus Protocol

 Custom settings for Andover Controls

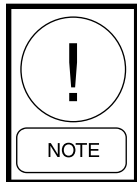

Reboot required (cycle power) after settings are changed.

The table below shows the real time error numbers that may be encountered during communication setup and a description of each.

TABLE 40 - REAL TIME ERROR NUMBERS

ERROR NUMBER (##)	DESCRIPTION
0	ALL OK
1	DATUM TYPE OK TEST FAILED
2	ENGLISH TEXT TOO LONG
3	FLOATING POINT EXCEPTION
4	GET PACKET FAILED
5	GET TYPE FAILED
6	INVALID UNIT CONVERSION
7	INVALID HARDWARE SELECTION
8	REAL TIME FAULT
9	SPANISH TEXT TOO LONG
10	THREAD EXITED
11	THREAD FAILED
12	THREAD STALLED
13	IO BOARD RESET
14	BRAM INVALID
15	BACNET SETUP FAILED

BACnet and Modbus Communications

Chiller data that can be read and modified using specific BACnet or Modbus Register Addresses; and the data associated with the addresses, is outlined in the following description:

Analog Write Points

This data can be read and modified using a BACnet or Modbus network connection. The Modbus Register Address for these points is 1025 + AV #.

Binary Write Points

This data can be read and modified using a BACnet or Modbus network connection. The Modbus Register Address for these points is 1537 + BV #.

Analog Read Only Points

This data can be read using a BACnet or Modbus network connection and can NOT be modified using this connection. The Modbus Register Address for these points is 513 + AI #.

Binary Monitor Only Points

This data can be read using a BACnet or Modbus network connection and can NOT be modified using this connection. The Modbus Register Address for these points is 1281 + BI #.

Refer to Table 41 for complete list of BACnet and Modbus registers.

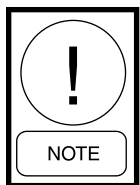

The latest data map information is listed on the Johnson Controls Equipment Integration website.

Communications Data Map Notes:

(See Table 41)

1. IPU II based units are configured for Native BACnet MS/TP and Modbus RTU communications. Microgateway or E-Link not required for these two communication protocols.
2. BACnet Object Types:

0 = Analog In	5 = Binary Value
1 = Analog Out	8 = Device
2 = Analog Value	15 = Alarm Notification (0 through 127 are reserved ASHRAE Objects).
3 = Binary In	
4 = Binary Output	
3. Abbreviations:

WC= Inches of water column	Pa = Pascals
CFM = Cubic Feet per Minute	kPa = Kilopascals
FPM = Feet per Minute	PPM = Part per Million
PSI = Lbs per square inch	kJ/kg = Kilojoules per Kilogram.
4. Water Cooled Scroll units use the same firmware as Air Cooled Scroll units, ignoring Fan Control.

YCAL/YCUL/YCWL/YLAA IPU II

Native Modbus and BACnet MS/TP Data Maps

Board: 031-02630-xxx w/ 031-02550

ITEM	Version	Date	York PN	Check Sum	Comments												
1	C.MMC.13.00	29-Nov-06	031-02755-001		Standard with Board: 031-02630-xxx w/ 031-02550												
2	C.MMC.15.00	29-Nov-06	031-02755-002		Basildon with Board: 031-02630-xxx w/ 031-02550												
3	C.MMC.14.00	29-Nov-06	031-02755-003		MMHP with Board: 031-02630-xxx w/ 031-02550												
4	C.MMC.16.00	29-Nov-06	031-02755-004		Basildon MMHP with Board: 031-02630-xxx w/ 031-02550												
5	C.MMC.13.02	17-Oct-08	031-02755-001		Standard Micro Board 031-02550-xxx . Fix native Modbus communications. Fix Caf� Metric functionality (SCR-766)												
6	C.MMC.14.02	17-Oct-08	031-02755-003		MMHP with Board: 031-02630-xxx w/ 031-02550 Fix native Modbus communications. Fix Caf� Metric functionality (SCR-766)												
7	C.MMC.16.02	17-Oct-08	031-02755-004		Basildon MMHP with Board: 031-02630-xxx w/ 031-02550 Fix native Modbus communications. Fix Caf� Metric functionality (SCR-766)												
8																	
9																	
10																	
ITEM REF NUM	BACnet NAME	BACnet Object/Inst ance	MODBUS ADDRESS	MODBUS Data Type Supported	ENG UNITS	READ WRITE	POINT DESCRIPTION	Point List Code									
								S=Standard; O = Optional; N = Not Available									
1					SEE NOTE 5		SEE NOTE 1	1	2	3	4	5	6	7	8	9	10
3	ANALOG WRITE POINTS																
4	REM_SETP	AV_1	1026	03,06,16	F�	R/W	Setpoint Cooling Setpoint(HP Only), 99 = Auto; (40°F - 70°F)										
5	SP_REM_SP_S1	AV_2	1027	03,06,16	PSIG	R/W	Sys 1 Setpoint (Suction Pressure Control units only)										
6	LOAD_LIMIT	AV_3	1028	03,06,16	index	R/W	Load Limit Stage (0, 1, 2)										
7	REM_CR	AV_4	1029	03,06,16	F�	R/W	Cooling Range (DAT Mode Only)										
8	SP_REM_SP_S2	AV_5	1030	03,06,16	PSIG	R/W	Sys 2 Setpoint (Suction Pressure Control)										
9	REM_SP_HEAT	AV_6	1031	03,06,16	F�	R/W	Heating Setpoint (HP Only), 999 = Auto (95°F - 122°F)										
10	HP_MODE	AV_7	1032	03,06,16	index	R/W	Mode (HP Only) (0=Panel, 1=Cooling, 2=Heating)										
11																	
12	BINARY WRITE POINTS																
13	START_STOP	BV_1	1538	01,03,05,15,06,	0, 1	R/W	Stop Start Command										
14	SS_SYS1	BV_2	1539	01,03,05,15,06,	0, 1	R/W	Sys 1 Start/Stop (Suction Pressure (SP) Control Only)										
15	SS_SYS2	BV_3	1540	01,03,05,15,06,	0, 1	R/W	Sys 2 Start/Stop (Suction Pressure (SP) Control Only)										
16	ANALOG READ ONLY POINTS																
17	LCHLT	AI_1	514	03,04	F�	R	Leaving Chilled Liquid Temp										
18	RCHLT	AI_2	515	03,04	F�	R	Return Chilled Liquid Temp										
19	DAT	AI_3	516	03,04	F�	R	Condensing Unit Models Only										
20	S1_SUCT_TEMP	AI_4	517	03,04	F�	R	Electronic Expansion Valve Models Only										
21	OAT	AI_5	518	03,04	F�	R	Ambient Air Temperature										
22	S1_SUCT_SHEAT	AI_6	519	03,04	F�	R	Sys 1 Suction Superheat (EEV Models Only)										
23	S1_RUN_TIME	AI_7	520	03,04	seconds	R	Sys 1 Run Time (seconds)										
24	S1_SUCT_PR	AI_8	521	03,04	PSIG	R	Sys 1 Suction Pressure										
25	S1_DSCH_PR	AI_9	522	03,04	PSIG	R	Sys 1 Discharge Pressure										
27	S1_CIR_TEMP	AI_10	523	03,04	F�	R	Sys 1 Cooler Inlet Refrigerant Temp (R-407c Models Only)										
28	S1_DEF_TEMP	AI_11	524	03,04	F�	R	Sys 1 Defrost Temperature (HP Only)										
29	S1_EEV_OUT	AI_12	525	03,04	F�	R	System 1 EEV Output % (EEV Models Only)										
30	S1_AR_TIMER	AI_13	526	03,04	seconds	R	Sys 1 Anti-Recycle Timer										
31	AC_TIMER	AI_14	527	03,04	seconds	R	Anti-Coincident Timer										
32	S2_SUCT_TEMP	AI_15	528	03,04	F�	R	System 2 Suction Temp (EEVModels Only)										
33	S2_RUN_TIME	AI_16	529	03,04	seconds	R	Sys 2 Run Time (seconds)										
34	S2_SUCT_PR	AI_17	530	03,04	PSIG	R	Sys 2 Suction Pressure										
35	S2_DSCH_PR	AI_18	531	03,04	PSIG	R	Sys 2 Discharge Pressure										
36	S2_CIR_TEMP	AI_19	532	03,04	F�	R	Sys 2 Cooler Inlet Refrigerant Temperature(R-407c Only)										
37	S2_DEF_TEMP	AI_20	533	03,04	F�	R	Sys 2 Defrost Temperature (HP Only)										
38	S2_SUCT_SH	AI_21	534	03,04	F�	R	Sys 2 Suction SuperHeat (EEV Models Only)										
39	S2_AR_TIMER	AI_22	535	03,04	F�	R	Sys 2 Anti-Recycle Timer										
40	S2_EEV_OUT	AI_23	536	03,04	seconds	R	Sys 2 Suction Superheat (EEV Models Only)										

TABLE 41 - BACNET AND MODBUS COMMUNICATIONS DATA MAP (CONT'D)

ITEM REF NUM	BACnet NAME	BACnet Object/Instance	MODBUS ADDRESS	MODBUS Data Type Supported	ENG UNITS	READ WRITE	POINT DESCRIPTION	Point List Code												
								S=Standard; O = Optional; N = Not Available												
								1	2	3	4	5	6	7	8	9	10			
41	NUM_COMPS	AI_24	537	03,04	count	R	Number of Compressors													
42	S1_OP_CODE	AI_25	538	03,04	index	R	Sys 1 Operational Code (See Table A & B)													
43	S1_FLT_CODE	AI_26	539	03,04	index	R	Sys 1 Fault Code (See Table A & B)													
44	S2_OP_CODE	AI_27	540	03,04	index	R	Sys 2 Operational Code (See Table A & B)													
45	S2_FLT_CODE	AI_28	541	03,04	index	R	Sys 2 Fault Code (See Table A & B)													
46	S1_DBG_CODE	AI_29	542	03,04	index	R	Sys 1 Debug Code													
47	S1_FAN_STAGE	AI_30	543	03,04	count	R	Sys 1 Condenser Fan Stage													
48	S2_DBG_CODE	AI_31	544	03,04	index	R	Sys 2 Debug Code													
49	S2_FAN_STAGE	AI_32	545	03,04	count	R	Sys 2 Condenser Fan Stage													
50	CONTROL_MODE	AI_33	546	03,04	count	R	Unit Control Mode (0=Leaving Water, 1=Return Water, 2=Discharge Air, 3=Suction Press, 4=Cooling, 5=Heating)													
51	AR_TIME	AI_34	547	03,04	seconds	R	Anti-Recycle Time (Programmed)													
52	LCHLT_CUT	AI_35	548	03,04	F°	R	Leaving Chilled Liquid Temp Cutout													
53	LOW_AMB_CUT	AI_36	549	03,04	F°	R	Low Ambient Temperature Cutout													
54	SUCT_P_CO_HT	AI_37	550	03,04	PSIG	R	Low Suction Pressure Cutout Heating (HP Only)													
55	L_SUCT_P_CO	AI_38	551	03,04	PSIG	R	Low Suction Pressure Cutout (Cooling on HP units)													
56	H_DSCH_P_CO	AI_39	552	03,04	PSIG	R	High Discharge Pressure Cutout													
57	COOL_SETP	AI_40	553	03,04	F°	R	Setpoint													
58	SP_SETP_S1	AI_41	554	03,04	F°	R	Setpoint 1 (SP Control)													
59	CONTROL_RG	AI_42	555	03,04	F°	R	Cooling Range													
60	SP_CTL_RG_S1	AI_43	556	03,04	F°	R	Cooling Range 1 (SP Control)													
61	SP_SETP_S2	AI_44	557	03,04	F°	R	Setpoint 2 (SP Control)													
62	HEAT_SETP	AI_45	558	03,04	F°	R	Heating Setpoint (HP Only)													
63	SP_CTL_RG_S2	AI_46	559	03,04	F°	R	Cooling Range 2 (SP Control)													
64	HEAT_RANGE	AI_47	560	03,04	F°	R	Heating Range (HP Only)													
65	S1_DSCH_TEMP	AI_48	561	03,04	F°	R	Sys 1 Discharge Temperature (EEV Only)													
66	S1_DSCH_SHEAT	AI_49	562	03,04	F°	R	Sys 1 Discharge Superheat (EEV Only)													
67	S2_DSCH_TEMP	AI_50	563	03,04	F°	R	Sys 2 Discharge Temperature (EEV Only)													
68	S2_DSCH_SH	AI_51	564	03,04	F°	R	Sys 2 Discharge Superheat (EEV Only)													
69	LEAVING_HOT	AI_52	565	03,04	F°	R	Leaving Liquid Hot Temp (R-410a)													
70	RETURN_HOT	AI_53	566	03,04	F°	R	Return Liquid Hot Temp (R-410a)													
71																				
72																				
74	BINARY MONITOR ONLY POINTS																			
75	S1_ALARM	BI_1	1282	01,02,03	0, 1	R	Sys 1 Alarm													
76	S2_ALARM	BI_2	1283	01,02,03	0, 1	R	Sys 2 Alarm													
77	EVAP_HTR	BI_3	1284	01,02,03	0, 1	R	Evaporator Heater Status													
78	EVAP_PUMP	BI_4	1285	01,02,03	0, 1	R	Evaporator Pump Status													
79	S1_C1_RUN	BI_5	1286	01,02,03	0, 1	R	Sys 1 Comp 1 Run													
80	S2_C1_RUN	BI_6	1287	01,02,03	0, 1	R	Sys 2 Comp 1 Run													
81	S1_LLSV	BI_7	1288	01,02,03	0, 1	R	Sys 1 Liquid Line Solenoid Valve													
82	S1_MODE_SV	BI_8	1289	01,02,03	0, 1	R	Sys 1 Mode Solenoid Valve (HP Only)													
83	S1_HGBV	BI_9	1290	01,02,03	0, 1	R	Sys 1 Hot Gas Bypass Valve													
84	S1_BHS	BI_10	1291	01,02,03	0, 1	R	Bivalent Heat Source (HP Only)													
85	S1_C2_RUN	BI_11	1292	01,02,03	0, 1	R	Sys 1 Comp 2 Run													
86	S2_C2_RUN	BI_12	1293	01,02,03	0, 1	R	Sys 2 Comp 2 Run													
87	S2_LLSV	BI_13	1294	01,02,03	0, 1	R	Sys 2 Liquid Line Solenoid Valve													
88	S2_MODE_SV	BI_14	1295	01,02,03	0, 1	R	Sys 2 Mode Solenoid Valve (HP Only)													
89	LEAD_SYS	BI_15	1296	01,02,03	0, 1	R	Lead System (0 = Sys 1, 1 = Sys 2)													
90	S1_C3_RUN	BI_16	1297	01,02,03	0, 1	R	Sys 1 Comp 3 Run													
91	S2_C3_RUN	BI_17	1298	01,02,03	0, 1	R	Sys 2 Comp 3 Run													
92	CH_LIQ_TYPE	BI_18	1299	01,02,03	0, 1	R	Chilled Liquid Type (0=Water, 1=Glycol)													
93	AMB_MODE	BI_19	1300	01,02,03	0, 1	R	Ambient Control Hot Mode (0=Std Amb, 1=Low Amb)													

TABLE 41 - BACNET AND MODBUS COMMUNICATIONS DATA MAP (CONT'D)

ITEM REF NUM	BACnet NAME	BACnet Object/Instance	MODBUS ADDRESS	MODBUS Data Type Supported	ENG UNITS	READ WRITE	POINT DESCRIPTION	Point List Code									
								S=Standard; O = Optional; N = Not Available									
								1	2	3	4	5	6	7	8	9	10
94	CNTL_MODE	BI_20	1301	01,02,03	0, 1	R	Local/Remote Control Mode (0=Local, 1=Remote)										
95	DATA_UNIT	BI_21	1302	01,02,03	0, 1	R	Units (0=Imperial, 1=SI)										
96	AUTO_LL	BI_22	1303	01,02,03	0, 1	R	Lead/Lag Control Mode (0=Manual, 1=Auto)										

TABLE A

Code	Operational Codes
0	No Abnormal Condition
1	Unit Switch Off
2	System Switch Off
3	Lock-Out
4	Unit Fault
5	System Fault
6	Remote Shutdown
7	Daily Schedule Shutdown
8	No Run Permissive
9	No Cool Load
10	Anti-Coincidence Timer Active
11	Anti-Recycle Timer Active
12	Manual Override
13	Suction Limiting
14	Discharge Limiting
15	
16	Load Limiting
17	Compressor(s) Running
18	
19	
20	
21	
22	
23	
24	
25	
26	
27	
28	
29	
30	

TABLE B

Code	Fault Codes
0	No Fault
1	VAC Under Voltage
2	Low Ambient Temperature
3	High Ambient Temperature
4	Low Leaving Chilled Liquid Temp
5	High Discharge Pressure
6	High Differential Oil Pressure
7	Low Suction Pressure
8	High Motor Current
9	LLSV Not On
10	Low Battery Warning
11	High Oil Temperature
12	High Discharge Temperature
13	Improper Phase Rotation
14	Low Motor Current / MP / HPCO
15	Motor Current Unbalanced
16	Low Differential Oil Pressure
17	Ground Fault
18	MP/HPCO Fault
19	Low Evaporator Temperature
20	Incorrect Refrigerant Programmed
21	Power Failure, Manual Reset Required
22	Unit Motor Current
23	Low Superheat
24	Sensor Fault
25	
26	MP/HPCO Inhibit
27	
28	
29	
30	

NOTES

1	The IPU II based YCAL /YCUL Units are configured for Native BACnet MS/TP and Modbus RTU communications. The Microgateway product is not required for these 2 interfaces
2	
3	BACnet Object Types: 0= Analog In, 1 = Analog Out, 2= Analog Value, 3= Binary In, 4 = Binary Output, 5= Binary Value, 8= Device, 15 = Alarm Notification (0 -127 are reserved ASHRAE Objects)
4	WC= Inches of water column; CFM = Cubic Feet per Minute; FPM = Feet per Minute; PSI = Lbs per square inch; Pa = Pascals; kPa = Kilopascals; PPM = Part Per Million; kJ/kg = Kilojoules per Kilogram
5	See the applicable Middle Market Chiller Operations Manual for more details
6	The YCWL uses the same firmware as a YCAL , it just ignores Fan Control
7	
8	
9	
10	

Yorktalk 2 Communications

Received Data (Control Data)

The unit receives eight data values from the MicroGateway or E-Link. The first four are analog values and the last four are digital values. These eight data values are used as control parameters when in REMOTE mode. When the unit is in LOCAL mode, these eight values are ignored. If the unit receives no valid YorkTalk 2 transmission for 5 minutes it will revert back to all local control values. Table 42 “Yorktalk 2 Communications Data Map” lists the control parameters. These values are found under feature 54 in the MicroGateway or E-Link.

Transmitted Data

After receiving a valid transmission from the MicroGateway or E-Link, the unit will transmit either operational data or history buffer data depending on the “History Buffer Request” on ENG PAGE 10. Data must be transmitted for every page under feature 54. If there is no value to be sent to a particular page, a zero will be sent. Table 42 “Yorktalk 2 Communications Data Map” shows the data values and page listings for this unit.

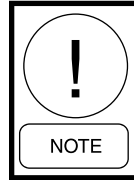

The latest point map information is listed on the Johnson Controls Equipment Integration website.

YCAL/YCWL/YLAA Middle Market w/ 2050, 2550

York Talk 2 MicroGateway / ELINK

Micro Board: 031-02050/02550

Item	Ref.	Version	Date	YORK P N	Checksum	Baud	COMMENTS										
1		C.MMC.03.02		031-02049-001	944D	4800	YCAL Micro Board 031-02050-xxx										
2		C.MMC.03.01		031-02049-001	964B	4800	YCAL Micro Board 031-02050-xxx										
3		C.MMC.03.00		031-02049-001	2226	4800	YCAL Micro Board 031-02050-xxx										
4		C.MMC.13.xx		flash	xxxx	4800	YCAL Micro Board 031-02550-xxx, IPU 2 board.										
5		C.MMC.13.xx		flash	xxxx	4800	YCWL (water cooled version) Micro Board 031-02550-xxx, IPU 2 board.										
6		C.MMC.13.02		flash	xxxx	4800	Micro Board 031-02550-xxx . Fix native Modbus communications (SCR . Fix Café Metric functionality (SCR-766)										
7																	
8																	
9																	
10																	
▼ Use ASCII page column for interfaces utilizing an ASCII XL Translator or MicroGateway to communicate to a chiller LINC																	
ENG PAGE REF	ASCII PAGE REF	GPIC Object Type	York Talk Point Type	ISN LINC Descriptive Text	York Talk Character Position	N2 Address	POINT LIST CODE: S = STANDARD O = OPTIONAL N = NOT AVAILABLE										ENG PAGE REF
							POINT LIST DESCRIPTION										
							1	2	3	4	5	6	7	8	9	10	
P03	P01		A. Control			ADF 1	Setpoint	S	S	S	S	S					P03
P04	P02		A. Control			ADF 2	Load Limit Stage (0, 1, 2)	S	S	S	S	S					P04
P05	P03		A. Control			ADF 3	Heating Setpoint (HP and YCWL HP)	O	O	O	O	O					P05
P06	P04		A. Control			ADF 4	Mode (HP and YCWL HP only) (0=Panel, 1= Cooling, 2 = Heating)	O	O	O	O	O					P06
P07	P05		D. Control			BD 1	Start/Stop Command	S	S	S	S	S					P07
P08	P06		D. Control			BD 2											P08
P09	P07		D. Control			BD 3											P09
P10	P08		D. Control			BD 4	History Buffer Request	S	S	S	S	S					P10
P11	P09		A. Monitor		8 - 11	ADF 5	Leaving Chilled Liquid Temp	S	S	S	S	S					P11
P12	P10		A. Monitor		12 - 15	ADF 6	Return Chilled Liquid Temp	S	S	S	S	S					P12
P13	P11		A. Monitor		16 - 19	ADF 7	Leaving Hot Liquid Temp (R-410a) Heat Mode Only	O	O	O	O	O					P13
P14	P12		A. Monitor		20 - 23	ADF 8	Discharge Air Temp (Cond Unit) Return Hot Liquid Temp (410a- Heat Mod	S	S	S	S	S					P14
P15	P13		A. Monitor		24 - 27	ADF 9	Leaving Liquid Temp Hot (R-410a)	O	O	O	O	O					P15
P16	P14		A. Monitor		28 - 31	ADF 10	Ambient Air Temperature	S	S	S	S	S					P16
P17	P15		A. Monitor		32 - 35	ADF 11	Sys 1 Suction Superheat (EEV only)	O	O	O	O	O					P17
P18	P16		A. Monitor		36 - 39	ADF 12	Sys 1 Run Time (seconds)	S	S	S	S	S					P18
P19	P17		A. Monitor		40 - 43	ADF 13	Sys 1 Suction Pressure	S	S	S	S	S					P19
P20	P18		A. Monitor		44 - 47	ADF 14	Sys 1 Discharge Pressure	S	S	S	S	S					P20
P21	P19		A. Monitor		48 - 51	ADF 15	Sys 1 Cooler Inlet Refrigerant Temperature(R-407c Only)	S	S	S	S	S					P21
P22	P20		A. Monitor		52 - 55	ADF 16											P22
P23	P21		A. Monitor		56 - 59	ADF 17	Sys 1 EEV Output % (EEV only)	O	O	O	O	O					P23
P24	P22		A. Monitor		60 - 63	ADF 18	Sys 1 Anti- Recycle Timer	S	S	S	S	S					P24
P25	P23		A. Monitor		64 - 67	ADF 19	Anti-Coincident Timer	S	S	S	S	S					P25
P26	P24		A. Monitor		68 - 71	ADF 20	Sys Suction Temp (EEV only)	O	O	O	O	O					P26
P27	P25		A. Monitor		72 - 75	ADF 21	Sys 2 Run Time (seconds)	S	S	S	S	S					P27
P28	P26		A. Monitor		76 - 79	ADF 22	Sys 2 Suction Pressure	S	S	S	S	S					P28
P29	P27		A. Monitor		80 - 83	ADF 23	Sys 2 Discharge Pressure	S	S	S	S	S					P29
P30	P28		A. Monitor		84 - 87	ADF 24	Sys 2 Cooler Inlet Refrigerant Temperature (R-407c systems Only)	S	S	S	S	S					P30
P31	P29		A. Monitor		88 - 91	ADF 25	Sys 2 Defrost Temperature (HP only)	O	O	O	O	O					P31
P32	P30		A. Monitor		92 - 95	ADF 26	Sys 2 Suction Superheat (EEV only)	O	O	O	O	O					P32
P33	P31		A. Monitor		96 - 99	ADF 27	Sys 2 Anti-Recycle Timer	S	S	S	S	S					P33
P34	P32		A. Monitor		100 - 103	ADF 28	Sys 2 EEV Output % (EEV only)	O	O	O	O	O					P34
P35	P33		A. Monitor		104 - 107	ADF 29	Number of Compressors	S	S	S	S	S					P35
P36	P34		D. Monitor		108	BD 5	Sys 1 Alarm	S	S	S	S	S					P36
P37	P35		D. Monitor		109	BD 6	Sys 2 Alarm	S	S	S	S	S					P37
P38	P36		D. Monitor		110	BD 7	Evaporator Heater Status	S	S	S	S	S					P38
P39	P37		D. Monitor		111	BD 8	Evaporator Pump Status	S	S	S	S	S					P39
P40	P38		D. Monitor		112	BD 9	Sys 1 Compressor 1 Run	S	S	S	S	S					P40
P41	P39		D. Monitor		113	BD 10	Sys 2 Compressor 1 Run	S	S	S	S	S					P41
P42	P40		D. Monitor		114	BD 11	Sys 1 Liquid Line Solenoid Valve	S	S	S	S	S					P42

TEMPERATURE CONVERSION CHART

Temperature Conversion Chart -
Actual Temperatures

°F	=	°C	°C	=	°F
0	=	-17.8	-18	=	-0.4
4	=	-15.6	-16	=	3.2
8	=	-13.3	-14	=	6.8
12	=	-11.1	-12	=	10.4
16	=	-8.9	-10	=	14
20	=	-6.7	-8	=	17.6
24	=	-4.4	-6	=	21.2
28	=	-2.2	-4	=	24.8
32	=	0.0	-2	=	28.4
36	=	2.2	0	=	32
40	=	4.4	2	=	35.6
44	=	6.7	4	=	39.2
48	=	8.9	6	=	42.8
52	=	11.1	8	=	46.4
56	=	13.3	10	=	50
60	=	15.6	12	=	53.6
64	=	17.8	14	=	57.2
68	=	20.0	16	=	60.8
72	=	22.2	18	=	64.4
76	=	24.4	20	=	68
80	=	26.7	22	=	71.6
84	=	28.9	24	=	75.2
88	=	31.1	26	=	78.8
92	=	33.3	28	=	82.4
96	=	35.6	30	=	86
100	=	37.8	32	=	89.6
104	=	40.0	34	=	93.2
108	=	42.2	36	=	96.8
112	=	44.4	38	=	100.4
116	=	46.7	40	=	104
120	=	48.9	42	=	107.6
124	=	51.1	44	=	111.2
128	=	53.3	46	=	114.8
132	=	55.6	48	=	118.4
136	=	57.8	50	=	122
140	=	60.0	52	=	125.6
144	=	62.2	54	=	129.2
148	=	64.4	56	=	132.8
152	=	66.7	58	=	136.4
156	=	68.9	60	=	140
160	=	71.1	62	=	143.6
164	=	73.3	64	=	147.2
168	=	75.6	66	=	150.8
172	=	77.8	68	=	154.4
176	=	80.0	70	=	158
180	=	82.2	72	=	161.6
184	=	84.4	74	=	165.2
188	=	86.7	76	=	168.8
192	=	88.9	78	=	172.4
196	=	91.1	80	=	176
200	=	93.3	82	=	179.6
204	=	95.6	84	=	183.2
208	=	97.8	86	=	186.8
212	=	100.0	88	=	190.4
216	=	102.2	90	=	194
220	=	104.4	92	=	197.6
224	=	106.7	94	=	201.2
228	=	108.9	96	=	204.8
232	=	111.1	98	=	208.4
236	=	113.3	100	=	212
240	=	115.6	102	=	215.6
244	=	117.8	104	=	219.2

Temperature Conversion Chart -
Differential Temperatures

°F	=	°C	°C	=	°F
0	=	0	0	=	0
4	=	2.2	2	=	3.6
8	=	4.4	4	=	7.2
12	=	6.7	6	=	10.8
16	=	8.9	8	=	14.4
20	=	11.1	10	=	18
24	=	13.3	12	=	21.6
28	=	15.6	14	=	25.2
32	=	17.8	16	=	28.8
36	=	20	18	=	32.4
40	=	22.2	20	=	36
44	=	24.4	22	=	39.6
48	=	26.7	24	=	43.2
52	=	28.9	26	=	46.8
56	=	31.1	28	=	50.4
60	=	33.3	30	=	54

Pressure Conversion Chart -
Gauge or Differential

PSI	=	BAR	BAR	=	PSI
20	=	1.38	1.5	=	21.8
30	=	2.07	2	=	29
40	=	2.76	2.5	=	36.3
50	=	3.45	3	=	43.5
60	=	4.14	3.5	=	50.8
70	=	4.83	4	=	58
80	=	5.52	4.5	=	65.3
90	=	6.21	5	=	72.5
100	=	6.9	5.5	=	79.8
110	=	7.59	6	=	87
120	=	8.28	6.5	=	94.3
130	=	8.97	7	=	101.5
140	=	9.66	7.5	=	108.8
150	=	10.34	8	=	116
160	=	11.03	8.5	=	123.3
170	=	11.72	9	=	130.5
180	=	12.41	9.5	=	137.8
190	=	13.1	10	=	145
200	=	13.79	10.5	=	152.3
210	=	14.48	11	=	159.5
220	=	15.17	11.5	=	166.8
230	=	15.86	12	=	174
240	=	16.55	12.5	=	181.3
250	=	17.24	13	=	188.5
260	=	17.93	13.5	=	195.8
270	=	18.62	14	=	203
280	=	19.31	14.5	=	210.3
290	=	20	15	=	217.5
300	=	20.69	15.5	=	224.8
310	=	21.38	16	=	232
320	=	22.07	16.5	=	239.3
330	=	22.76	17	=	246.5
340	=	23.45	17.5	=	253.8
350	=	24.14	18	=	261
360	=	24.83	18.5	=	268.3
370	=	25.52	19	=	275.5
380	=	26.21	19.5	=	282.8
390	=	26.9	20	=	290
400	=	27.59	20.5	=	297.3

R410-A PRESSURE TEMPERATURE CHART

ADDING REFRIGERANT CHARGE AFTER COMMISSIONING

This unit utilizes HFC 410A refrigerant. HFC 410 A is a blend refrigerant containing both HFC-32 and HFC-125 (50/50 wt %). As this blend performs very much like a single component refrigerant due to the closeness of the individual refrigerant boiling points, any change

in composition due to a leak will be minimal. For this reason, you may add to the charge at any time. It is not necessary to remove the entire charge and weigh a new charge in. It is important to remember to add this additional charge as a liquid following all applicable safety procedures, and only after identifying and properly repairing any leak found.

PSIG	TEMPERATURE °F	PSIG	TEMPERATURE °F
0	-60	78	20
2	-58	80	21
4	-54	85	24
6	-50	90	26
8	-46	95	29
10	-42	100	32
12	-39	105	34
14	-36	110	36
16	-33	115	39
18	-30	120	41
20	-28	125	43
22	-26	130	45
24	-24	135	47
26	-20	140	49
28	-18	145	51
30	-16	150	53
32	-14	160	57
34	-12	170	60
36	-10	180	64
38	-8	190	67
40	-6	200	70
42	-4	210	73
44	-3	220	76
46	-2	225	78
48	0	235	80
50	1	245	83
52	3	255	85
54	4	265	88
56	6	275	90
58	7	285	92
60	8	295	95
62	10	305	97
64	11	325	101
66	13	355	108
68	14	375	112
70	15	405	118
72	16	500	134
74	17	600	149
76	19	700	159



P.O. Box 1592, York, Pennsylvania USA 17405-1592

Copyright © by Johnson Controls 2016

Form 150.67-NM1 (1016)

Issue Date: October 7, 2016

Supersedes 150.67-NM1 (312)

800-861-1001

www.johnsoncontrols.com

Subject to change without notice. Printed in USA

ALL RIGHTS RESERVED